

FLAX-MACHINES. When flax is pulled, the stalk may be said to be made up of three distinct parts. There is first the wood, then the bark, and lastly the glossy varnish of the bark. The woody matter in flax is of no value; the difficulty is how to get rid of it and to save the bark. To accomplish this the flax must be retted, and it is either spread over a field and exposed to the weather for some time, which is called "dew-retting," or the straw is steeped in water. In a short time the vegetable part rots, the gum on the outside dissolves, and the stalks are taken out of the water and dried. But the wood is like a fixed finger inside a glove, and, although weakened, has still to be removed. Scutching is the process by which the wood is removed and the outside skin saved. The difficulty is to get the woody part out without injury to the skin, which is the valuable part of the plant and forms the flax-fiber. There are four methods of doing this. The first is by striking the flax repeated blows, then taking it in handfuls, holding it over a wooden rest, and striking it sharp blows with a wooden blade. The second plan is to run the retted straw through fluted iron rollers, and when the heart is thus broken into short bits to take the straw in handfuls and hold it against two end blades rapidly revolving upon a shaft. The process known as the "Cardon" process, and which promised great things a short time ago, consists in pricking the straw with needles. This cuts the straw into lengths so small as to make it practically dust. The straw comes easily away. But it is obvious that the skin is damaged at the same time, because the heart of the stalk must be got at through this outer skin.

The Spiegelberg Flax-Scutching Machine (Figs. 1 and 2).—A new scutching-machine has been devised by Mr. A. Spiegelberg, which is claimed to show material improvement over older devices. The flax-straw is fed into the machine, one end always overlapping the preceding one. Heavy fluted rollers flatten the tubular stalks, which action does not spoil the fiber, but only takes the resistance out of the straw. Then the flax proceeds to the small rollers, lightly fluted, just sufficient to obtain a thorough grip of the flax, and by means of suitable mechanism these rollers receive a lateral or shaking motion, which bends the stalks and al-

lows the wood to fall out, and also prevents the outer skin from becoming crushed or cut, as is the case with the needle-points, or the series of fluted rollers—run at a high speed—of other machines. The fiber then passes to the second part of the machine, as illustrated herewith, which somewhat resembles an intersecting heckling-machine. The “strike” of flax is secured between a pair of India-rubber gripping-rollers $C C^1$, which bring it into contact with a pair of rapidly revolving beaters $D D^1$. After this operation has gone on for a given time the beaters are caused to revolve in the opposite direction, the gripping-rollers $C C^1$ and $E E^1$ are respectively automatically opened and closed in the interval by means of cam-bars $F F^1$, and the cams G and levers H . In this manner both ends of the strike are sufficiently operated

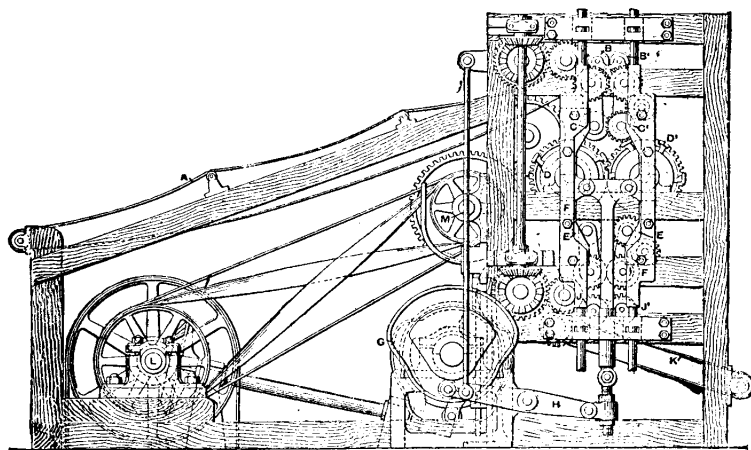

FIG. 1.

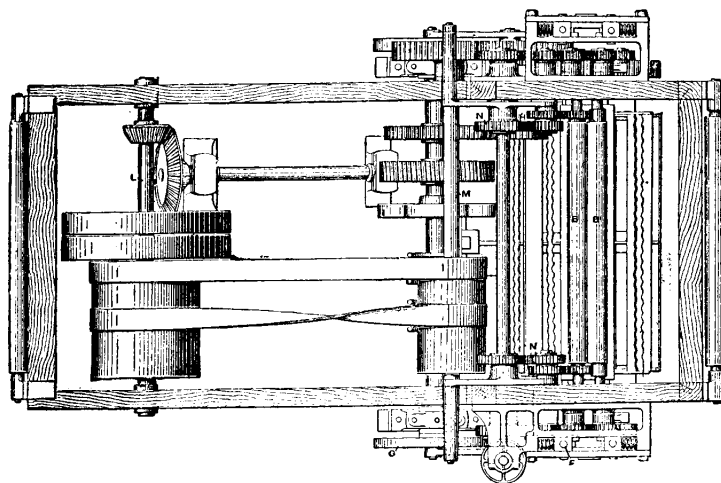

FIG. 2.

FIGS. 1, 2.—Spiegelberg flax-scutching machine.

upon before they are allowed to proceed downward to the delivery roller $J J^1$, and thence to the delivery-apron K . L is the first-motion shaft, carrying fast and loose pulleys, connected with similar pulleys on the shaft M , from which the beaters are driven. The taking-in rollers $B B^1$ derive motion from suitable gearing N , which is so constructed as to allow itself to become automatically disengaged upon the reversal of the machine. The principal part of the process, however, is that involved in the breaking-machine, which can not be substituted by hand or other process, while the cleaning might be done in the ordinary way; in fact, when the flax is well retted the breaking is done so completely that a little handling cleans the fiber entirely from all show. The two machines may be worked separately. It is obvious that, the fiber being uninjured, there is a much larger output, and the heckle gives far more yield in line. About the importance of scutching there can be no question. Vast countries produce grasses and fibers which are of the highest value. The difficulty always has been to separate the fiber from the gummy exterior and from the inside pith or wood.

The Wallace Flax-cleaning Machine.—A flax-cleaning machine of novel design, devised by Mr. John O. Wallace, of Belfast, Ireland, is illustrated in Fig. 3. It is shown with the but-

fer alongside, which is used for dislodging the woody matter. The machine is about 6 ft. 6 in. high by 4 ft. wide, and 5 ft. long over all; its working capacity being put at 1 cwt. of retted flax per hour. It consists of an upper feed-table, on which the flax straw is fed to three pairs of fluted rollers, which deliver the flax downward between five pairs of pinning-tools, alternating with six pairs of guide-rollers. The pinning-tools somewhat resemble hand-hackles, and are attached to two vertical frames, to which a horizontal to-and-fro motion is imparted, and the pins interlace as the two sides approach. The fibrous material is drawn downward by the rollers, which have an intermittent motion, and at each momentary pause the pricking-pins enter the material and are rapidly withdrawn from it. By degrees this fibrous descending curtain is delivered on to a sloping receiving-table at the bottom of the machine,

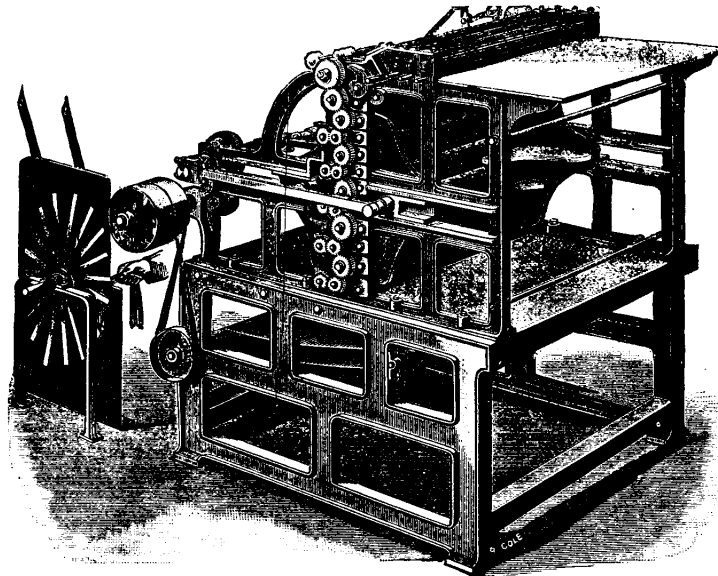

FIG. 3.—Wallace flax-cleaning machine.

over which table the woody substance has previously passed to a receiver in a crushed and semi-pulverized condition and perfectly free from fiber. Three attendants are required for one machine; but when large quantities of fiber have to be cleaned the same attendants are sufficient for three or four of the machines placed alongside each other. The attendants for one machine for flax are a boy or a girl to prepare straw in bundles, another to feed the straw to the machine, and a man to attend the buffer to clear off the broken woody portions. The two attendants who prepare the bundles and feed the straw can attend to two other machines, but each machine must have a man to buff or clean the flax. The driving power for each machine is two horse-power. It is claimed that this machine can be successfully used for cleaning ramie or rhea fiber.