

THE ELECTRIC DRIVING OF COTTON-PICKING MACHINERY

By Albert Walton

AFTER the cotton bale has been opened by the hand-cutting of the steel bands which were put on in the compress it is found to consist of rough layers of a more or less compact nature, their long confinement under pressure having wadded them into a tough mass. Bits of leaves and particles of seeds and husks are present, together with a certain amount of sand and grit. Before the cotton can be carded, drawn and spun its fibres must be separated from one another and from this grit and other foreign matter. The knotty tufts must be opened out and the whole brought to a clean and fluffy condition. To do this, important but rough-work "picking" machinery is provided in all cotton mills. These are the coarsest and most massive machines in the entire mill and, through long experience, have become well standardized, the usually accepted sequence being as follows, though some variations in the processes exist to accomplish certain ends in mills whose product is out of the ordinary:

1. Bale breaker, or hopper bale opener.
2. Opener.
3. Breaker.
4. Intermediate.
5. Finisher.

The opener and breaker are quite frequently combined as one machine, but not always. The functions of these various machines are all very similar. The bale opener breaks the compact layers up into tufts, still more or less compact, which are further broken up in the opener, where also the first cleaning action takes place.

A suction fan in the breaker draws the fleece from the opener in a continuous stream through a broad, flat flue or "trunk," the rate of motion being slow enough to allow much of the heavier dust to settle into slots or pockets, while the cotton passes forward. The breaker repeats the process of the opener, further opening the tufts and separating the fibres, while, at the same time, cleaning them. Both of these machines make use of rapidly revolving beaters in an iron cage. The bottom of the cage is a grid, which allows the dirt to be driven through, while too finely spaced to permit the tangled fibres to pass. The cotton is fed to the beater in a rough blanket, about 40 inches wide. This is broken up by the beater blades and drawn from the cage by a second suction fan, formed into a sheet and rolled up about an iron mandrel. This roll is called a "lap" and any of the machines which form such rolls are called "lappers."

Inasmuch as one of these laps will eventually be drawn out and spun into many miles of fine yarn, it is desirable to secure, even at this early stage, great cleanliness and uniformity. With this end in view four of these laps are now fed simultaneously to a third machine, called an intermediate. This quadruple sheet is again beaten apart and again spread out and wound up as a cleaner and more uniform lap. With the thoroughness characteristic of a cotton mill this process is again repeated by feeding four of the laps from this intermediate into a similarly constructed machine, called a finisher. The lap formed on the

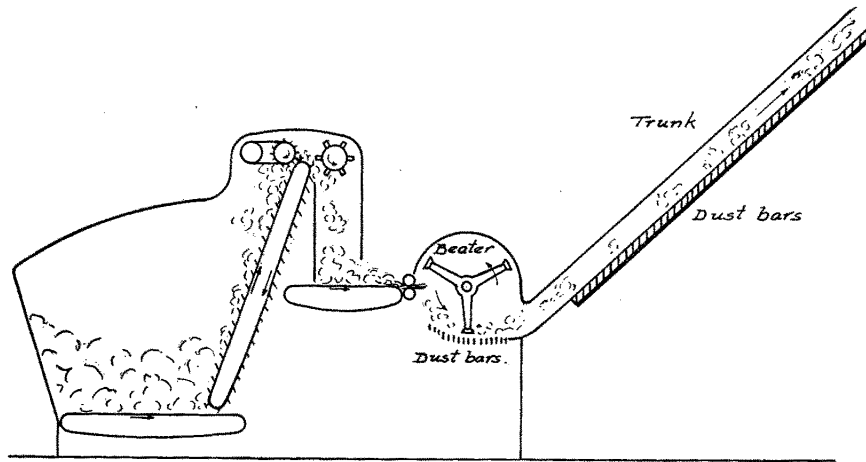

FIG. 1.—DIAGRAM SHOWING ARRANGEMENT OF ESSENTIAL PARTS OF AN OPENER PICKER WITH INCLINED TRUNK TO BREAKER ON THE FLOOR ABOVE

finisher is about 40 inches wide and 16 inches in diameter, contains about 50 yards of loosely laid cotton, about half an inch thick, and weighs within very close limits about 45 pounds. A variation in weight of over 1 per cent. from a fixed figure is enough to throw the lap out and necessitate its passing through the finisher a second time.

With this machine the rough unifying and cleaning process is completed and the finer work begins, the lap passing on from here to the cards and other machines of the later processes. With this explanation and the diagrammatic sketches, what follows may be more readily comprehended by those unfamiliar with the machines themselves.

ESTABLISHED METHODS OF DRIVING PICKERS.

For half a century pickers have been driven in the same fashion. A long belt from the line shaft passes to tight and loose pulleys on a countershaft, which is part of the machine itself and upon which is carried the large driving pulley, which belts to the small pulley on the beater. This high-speed countershaft is a necessity, since the line shaft runs at a relatively low speed,

while the beater requires from 1,100 to 1,500 revolutions per minute. The countershaft usually runs about 500 revolutions per minute, and, in addition to serving as a means of speed multiplication, serves as the point of control, the machine being stopped and started by the motion of a small handle on the side of the superstructure operating a shipper fork, which controls the position of the belt on tight or loose pulley.

The picker is normally started but twice a day—morning and noon—its operation being practically continuous from then till shut down for noon or night. In the first two stages of the process (opener and breaker), the action is entirely continuous except for accidental clogging of the cotton. In the last two (intermediate and finisher) the desirability of producing laps of a uniform weight has made necessary the provision of an automatic device for stopping the "feed" after a certain number of revolutions have been made by the rolls forming the lap. This occurs about every 8 minutes, but at this time the main belt is not shifted and the counter, beater and fans, comprising half the working load, continue to revolve. In some mills this is a source of waste

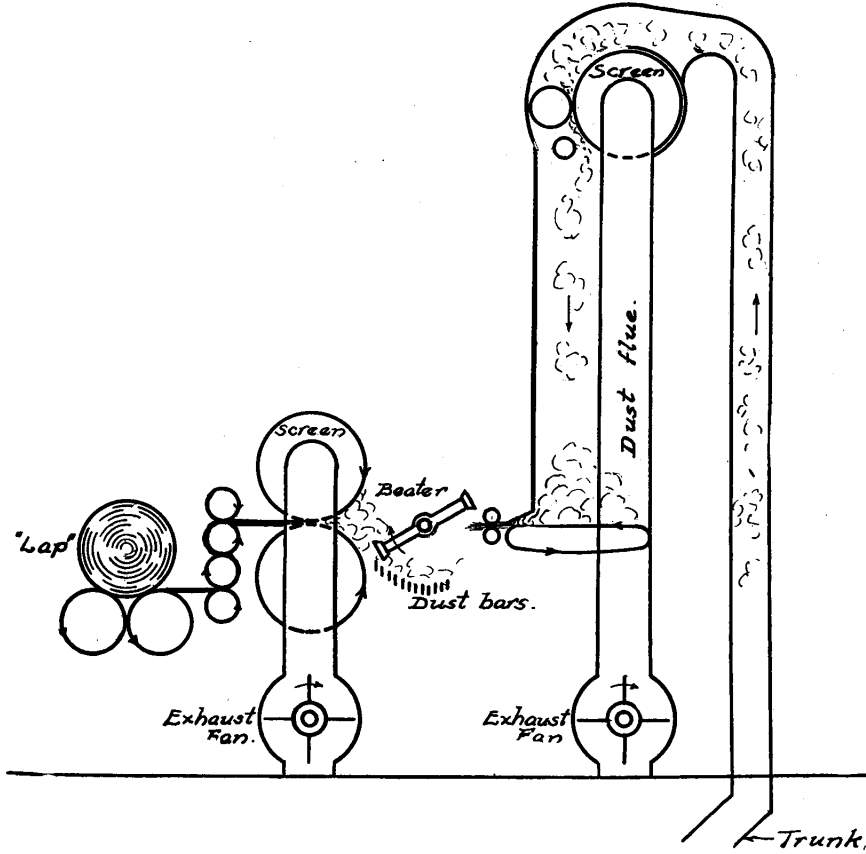

FIG. 2.—DIAGRAM OF ESSENTIAL PARTS OF BREAKER-PICKER RECEIVING COTTON THROUGH TRUNK FROM OPENER

of power, but in as many the work is so nicely timed that the completed lap is removed and the feed started for a new lap in a very few seconds after the automatic stop motion has acted.

DISADVANTAGES OF PRESENT METHOD

The disadvantages of the present drive are four-fold. It has an element of danger, is inefficient and lacking in neatness, and puts the machine under undue operating strains.

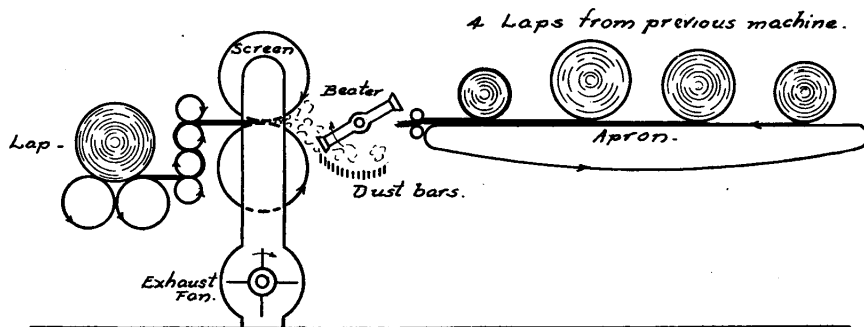

FIG. 3.—DIAGRAM OF INTERMEDIATE AND FINISHER PICKER

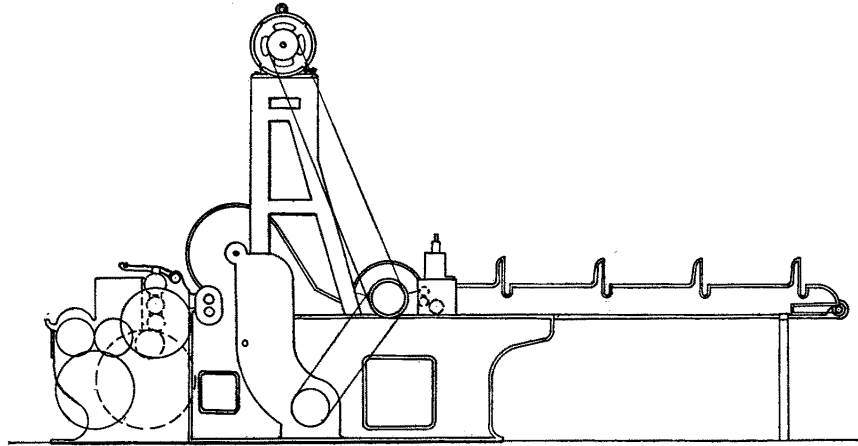

FIG. 4.—WESTINGHOUSE NO. 4 B. T. TEXTILE TYPE MOTOR AND KITSON ONE-BEATER FINISHER

It is a source of danger, because the high-speed belt, from counter to beater, runs over an unguarded pulley at about the level of the operative's hands and between him and parts of the machine which must be handled. It is inefficient primarily because the picker room is a bad place for a belt drive, and secondarily, because this drive in particular is a bad one. Every belt in a picker room has to be "carded" or cleaned of its accumulation of lint very frequently. On the belts from line shaft to line shaft and from line to counter this is both bothersome and risky, while on the belt from counter to beater it is frequently dangerous. Yet before the cleaning time has come around again the belts are lined with lint and are again liable to be slipping badly. To reduce this slippage excessive tensions are used, causing undue wear on all parts so driven. This is of importance on the beater bearings not alone because of the cost of replacement but because of the resulting change in the adjustment of the distance from the heater blades to the nip between the rolls, thus affecting the work done by the picker.

Not only does the lint collect on the belts and pulleys, however; the air is full of it and large quantities

settle on the countershaft superstructure and the overhead shafting and hangers, the belts carrying it from point to point. It drains the oil reservoirs and clogs the boxes, and for successful operation should be cleaned off at least once a day and sometimes more frequently. This necessitates clambering over the machines after quitting-time and is an item in picker-room maintenance that might well be dispensed with.

Power is used to no advantage when belts slip, but even where no slippage is occurring this system consumes quantities of power in its tight belts and high-speed shafts, amounting in the best of installations to 25 per cent. of the total power delivered to the room. Of prime importance, however, to the mill man is the item of production. It is a very rare case indeed in which the beater shafts will be found to be at the speed they are designed to run. The importance of this is understood when it is realized that the feeding parts and the lap rolls are driven directly from this beater shaft, thus being affected directly by any change in speed of this part, a falling off meaning a proportional loss in production of the machine. In one well-known mill in America the following speed readings were

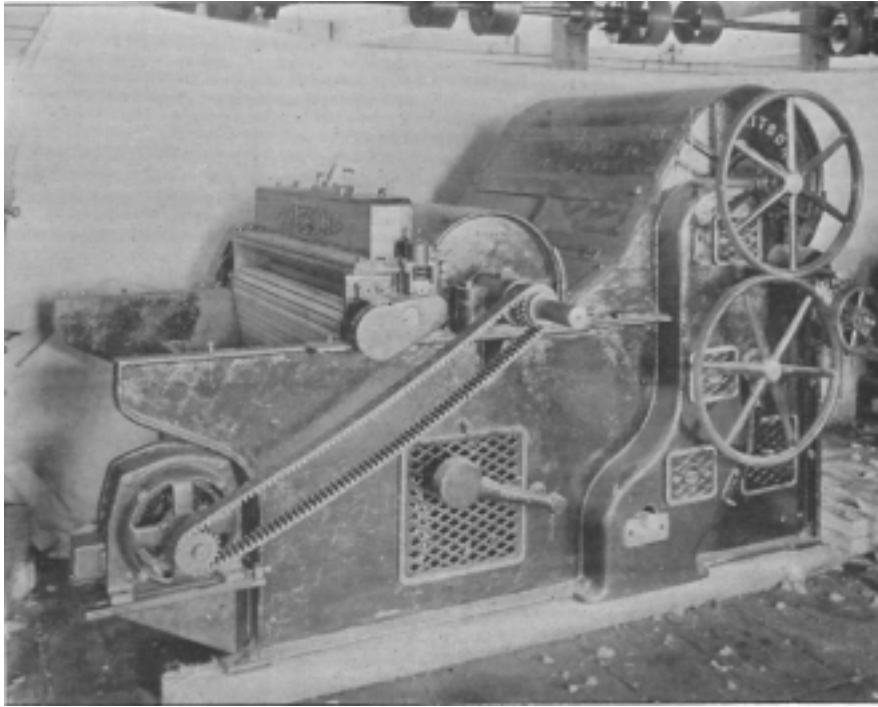

FIG. 5.—SECTION OF A FINISHER PICKER IN COURSE OF ERECTION, WITH GENERAL ELECTRIC MOTOR DRIVING A KITSON PICKER WITH MORSE SILENT CHAIN

actually taken on beater shafts said to be running at 1,300 revolutions per minute:

1,212	1,095
1,198	1,185
1,196	1,193
1,180	1,202
1,202	1,190
1,115	1,087
1,080	1,102
1,140	1,196
1,192	1,188
—	—
Average 1,172	1,160

In this case five belts intervened between the source of power, a pair of large water-wheels, and the beater shafts. Since this includes the two belts on the picker, it will be seen that the drive was very direct and that in the average mill this number of belts will generally be found exceeded rather than reduced.

GROUP DRIVE WITH ELECTRIC MOTORS

Only a slight amelioration of these conditions was effected when the electric motor was belted to the line shaft of the picker room, since the objectionable elements still remain. However, this was a step in the right direction. The picker room is always capable of supplying more cotton than the mill needs, so it usually works an eight or nine hour day, while the mill is running one or two hours more. The electric drive permitted the stopping of this section independently of the rest of the mill, so that cleaning-up could be finished by the usual quitting time, as well as effecting a saving in friction losses.

With this system we still have all the belts and speed fluctuations of the direct-engine drive, and all its other drawbacks. The introduction of electricity into the room has, however, made possible the use of the

individual motor, which, as we will show, can be made to eliminate, at once, all the undesirable features of the old-fashioned drive. In addition to this it introduces two entirely new items into picker driving, which are attracting much attention and interest. The drive in all of its applications is a simple one, yet one that has required not a little experimentation to perfect. There are three different methods of applying the motor to its work, no one of which best fits all cases, any one of them being used as occasion demands only after a thorough investigation by a capable engineer. The motor may be placed on the ceiling above the picker and connected by belt to the beater shaft without intermediate reduction, or it may be mounted on a bracket on the picker side and drive through a silent chain or, again, it may be placed directly upon the beater shaft without any transmission device whatever. Each drive has its distinct peculiarities, the advantages of which we will discuss separately.

BELT DRIVE FROM INDIVIDUAL MOTOR

While mounting the motor on the ceiling and belting down to the beater shaft has much to recommend it, it still retains one of the uncertain elements of the old drive—the lint-covered leather belt. A comparison of the two drives will quickly show, however, that the change is greater than this bare statement would imply, for, while all belts in a picker room are subject to slippage from lint, the conditions under which the belt to the beater shaft runs are greatly improved. The old drive was nearly vertical and the distance between pulley centers was less than six feet, in addition to which the ratio of pulley diameters was about three to one, making, all in all, one of the most unsatisfactory belt drives imaginable. With the substitution of the motor for the counter we get a 12-foot drive which can be arranged at an angle from the vertical, the

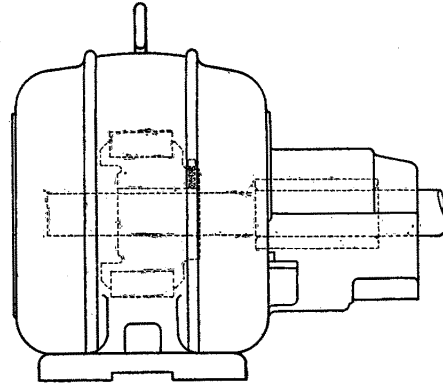

FIG. 6.—SPECIAL WESTINGHOUSE PICKER MOTOR WITH PICKER BEARING AN INTEGRAL PART OF MOTOR

pulley ratio being nearly one to one. Thus, while a lint-covered belt is still retained, belt-wrap is greatly improved, excessive belt tension is thereby avoided, and a more practical angle of belt inclination made possible. The costly and objectionable countershaft superstructure is eliminated and with it go all the overhead belting and shafting in the room. The motor being located on the ceiling is both an advantage and a drawback. It is out of the worst dust, yet is, by the same token, out of reach for inspection and cleaning. Similarly, while the belt is a source of slippage and loss of production, and carries lint up to the motor, it also provides a certain flexibility of transmission which may be deemed very desirable in certain cases. Where pickers are liable to choking or clogging a certain degree of protection to the feed gears is accorded just as with the old drive by the tendency of the belt to slip and on severe stoppages to run off the pulley entirely. This can, however, be taken care of more satisfactorily by circuit breakers in the motor wiring, as will be explained later. Nevertheless, after all is said and done, the belt remains with this system an element of weakness and danger, and this is true whether the motor be

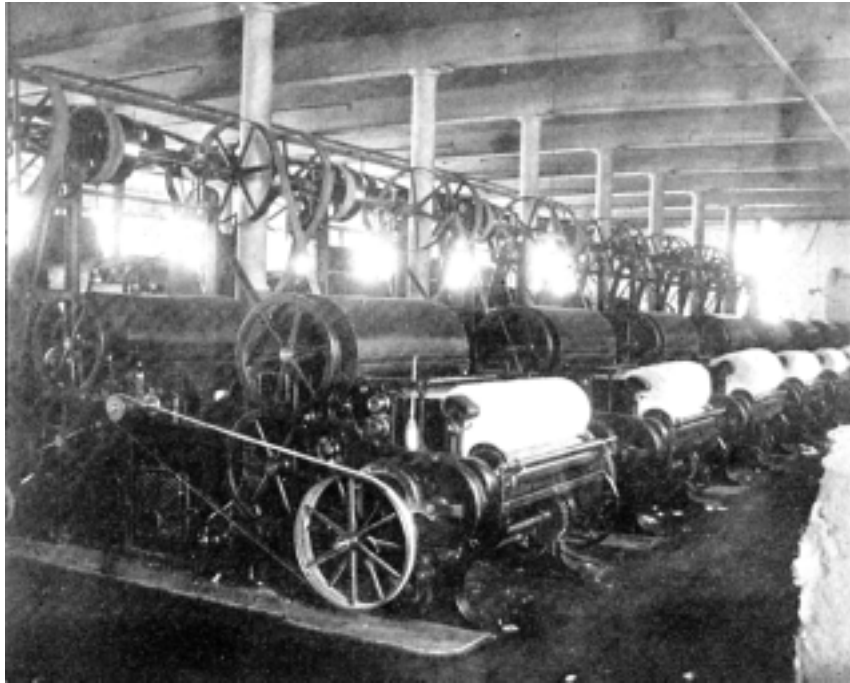

FIG. 7.—A PICKER ROOM DRIVEN BY THE OLD SYSTEM WITH BELTS AND SHAFTING

placed on the ceiling or on a stand similar to the countershaft stand, as has been done in some cases. Only half the step has been taken and not all the possibilities of the individual drive have been realized. To gain the full advantage of the change the even rotative speed of the motor should be transmitted to the beater without chance of slippage. To accomplish this, three possibilities present themselves—gears, chain and direct connection. Gears, so far as we know, have never been tried, and it seems unlikely that they would operate successfully, owing to the high speeds of rotation. Both of the other methods have been tried and are in operation at the present time.

CHAIN DRIVE

For such machines as cannot be driven by direct connection, owing to considerations of speed, a silent power chain forms a convenient method of transmitting the power without possibility of slip or loss of

production. The motor is placed on a bracket on the side of the picker, either on a level with the beater shaft and in front of it, or back of the shaft and down under the apron or corresponding part of the machine. In this drive we have the motor at a convenient level for inspection and oiling, but also in a very dusty location. With present "textile-type" motors this latter consideration is of little importance, since the construction is dustproof throughout and needs little cleaning. The chain can be enclosed and danger from this source eliminated. A circuit breaker is placed in the motor circuit when clogging is of sufficiently common occurrence to warrant it. The clogging puts a heavy load upon the motor, which instantly draws a heavy current from the line tripping the automatic circuit breaker and cutting off the power. The motor at once comes to rest and all strain is avoided. Thus, while the drive is unyielding and permits no slip, the

strain beyond which it is desired not to go can be predetermined and the device arranged to cut out at that point.

We are now certain of our picker speed remaining at the desired maximum, have eliminated all the overhead work in the room and the cleaning incident to its maintenance and have obviated the liability to breakage, due to choking of the cotton, but we still have a transmission element, the elimination of which is a step still further in advance.

DIRECT CONNECTION

Desirable as is direct connection, it is not possible to accomplish the best results by its application in all cases. The method is the acme of simplicity and efficiency. The superstructure is removed, as in the previous cases, and the eight or ten-inch pulley taken from the beater shaft. This leaves one end of this shaft clear, with the exception of a small pulley, which drives the fan near the bottom of the picker. This fan drive is transferred to the other

side of the picker by removing the fan shaft and replacing it "end for end," this being easy of accomplishment, since the fan is held on the shaft only by set screws. With the driving pulley for this fan now on the other end of the beater shaft we have one end entirely free of pulleys and extending 10 inches beyond the end of the large bearing housing whose outer end is itself some 6 or 7 inches beyond the straight side of the frame. There is thus plenty of room to place a motor armature on this shaft extension and to so mount the stationary "fields," or primary, that the armature will revolve freely within it. The shaft is rigid in the extreme, being not less than $2\frac{1}{8}$ inches in diameter, and no bearings are required on the motor itself. The motor frame, resting securely on a cast iron bracket bolted to the picker side, touches the armature or shaft at no place, merely surrounding it and causing it to revolve in its accustomed place and with the usual clearance between stator and rotor. Although this

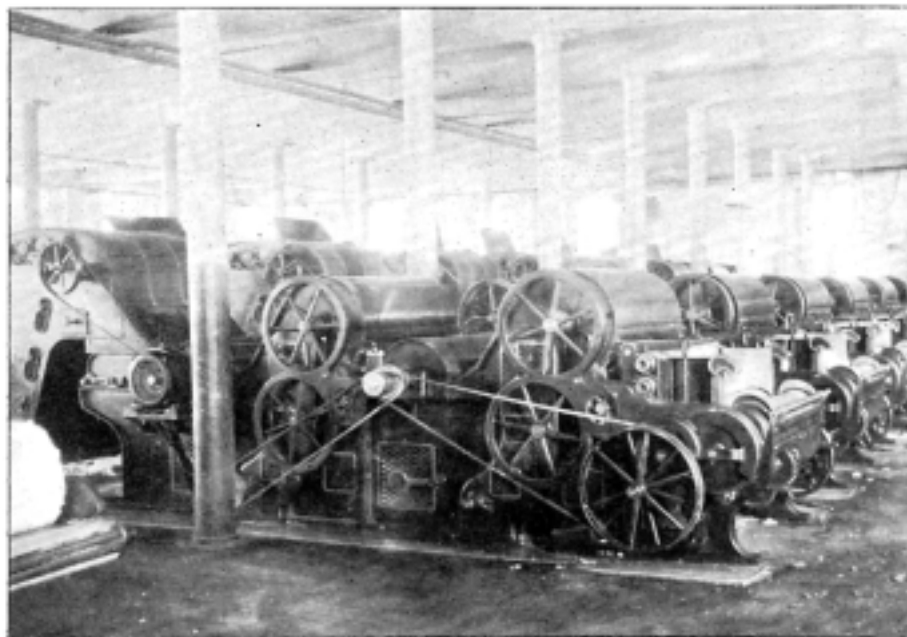

FIG. 8.—THE SAME ROOM AS SHOWN IN FIG. 7, AFTER THE INSTALLATION OF INDIVIDUAL MOTORS

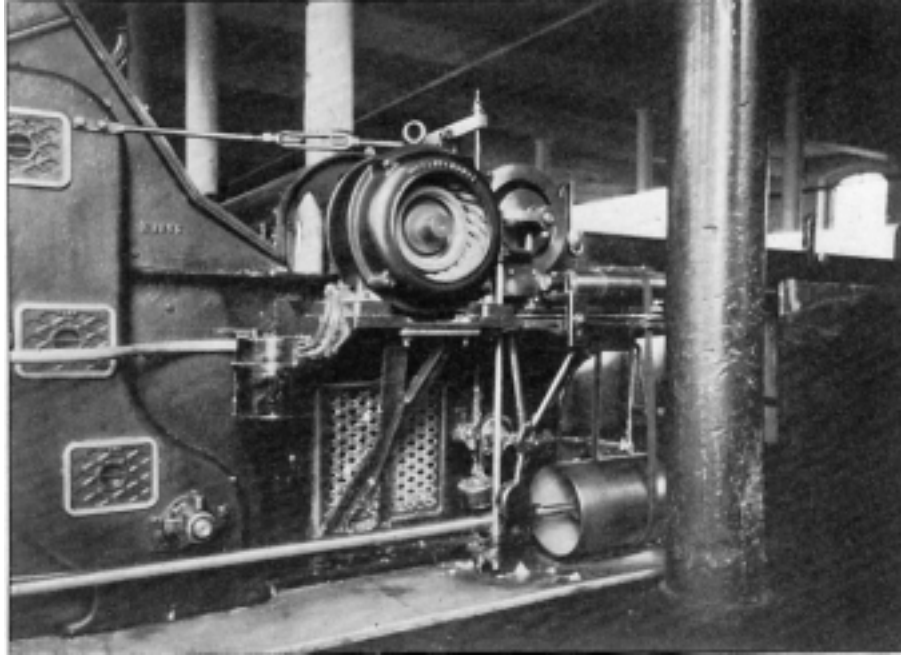

FIG. 9.—DETAIL OF WESTINGHOUSE PICKER MOTOR, SHOWING ROTOR ON BEATER SHAFT

clearance is relatively small, it is sufficient, because the beater shaft is held in a perfectly central position by two heavy bearings more than 40 inches apart, and because considerations of mechanical strength have made it necessary to use so liberal a shaft with the old belt drives. It is not only not necessary to cut or alter the beater shaft in any way, but it is not desirable to do so, since it is frequently necessary to reverse the beater shaft end for end in its bearings, so as to bring into play the reverse edges of the blades. When both edges of the beater are dulled by service it is removed and sharpened. The motor must be so arranged that it can be easily removed, just as the pulley was formerly taken off, and the shaft must be left of standard diameters, so pulleys and motor are interchangeable and can be placed on either end.

For this drive an automatic circuit breaker is used if the work demands its installation. If choking of the beater or calender is a remote pos-

sibility, an ordinary oil-immersed textile type switch is used. If the cycle of operations is such that the lap may be completed while the attendant is busy elsewhere, and the machine thereby be allowed to run idle from time to time for any considerable period, the switch or circuit breaker can be attached to the same lever by which the feed is automatically disconnected, so that the power may also be cut off, thus affecting a saving in this direction. Usually the work is so arranged that the operator is at hand upon the completion of each lap to remove it instantly and start the feed for another.

Unfortunately it is not possible to design polyphase alternating-current motors to run at all speeds. The nature of the motor confines the designer to certain fixed speeds and these are, in the usual American plant, 1,750, or 1,150 revolutions per minute for 60 cycles, or the latter for 40 cycle plants. Much divergence of opinion exists as to the best speed at which to run beaters,

but without radical change of design it seems to be conceded that 1,750 revolutions are too fast for good results, although direct connection to a motor of this speed was, we understand, attempted by an over-enthusiastic advocate of the drive. On the other hand, common practice with belts seems to indicate a speed somewhere between 1,350 and 1,500 revolutions on the last two machines of the picker room, and from 800 to 1,200 on the others, with a large majority running near the latter

and well-known mills in New England have just installed this method of drive on a total of 175 pickers, on practically all of which the beaters were running from 1,300 to 1,400 revolutions per minute. In both of these mills complete belt and shafting drive has been thrown out and first cost has not entered the problem in either case. In one mill the drive replaces engine drive, and the predominating consideration was one of speed, the slippage in transmission having proved excessive and



FIG. 10.—A LARGE PICKER ROOM DRIVEN BY DIRECT-CONNECTED MOTORS

figure. However, in many cases there is no good reason to suppose that 1,150 turns will not produce as good results as the higher speeds, which have been maintained largely as an unquestioned matter of habit. It has been found on certain staples and grades that a slower speed is an advantage, and, in other instances, that at the lower speeds no difference in the cleaning and beating was perceptible, the rate of feed in pounds per minute being maintained the same. As a result, two very large

very erratic. In the second the determining factor was one of power economy and general efficiency, the direct drive replacing a belt drive from two 150-horse-power motors and showing a power saving that will pay for the change in about four years, not counting the credit items of the two motors and the scrap value of belts, shafting and machine parts.

The broad experience gained in equipping these mills and the success met with have induced the electric



FIG. 11.—VIEW OF PICKER ROOM WITH BELT DRIVE, SHOWING MASS OF OVERHEAD WORK OBSTRUCTING LIGHT FROM WINDOWS



FIG. 12.—VIEW OF ABOVE PICKER ROOM AFTER INSTALLATION OF INDIVIDUAL ELECTRIC DRIVE

companies to perfect a motor for this class of work. The essential parts of the "picker motor" are the same as the standard textile-type motors, but it was found that the task of aligning the stator of the motor with the rotor was rather a painstaking one, although once in the proper position it required little attention and no realigning for many months. Nevertheless, to eliminate this feature and to secure a more perfect bearing than is used on the usual picker, the new motor is provided with a special end-bracket with a large babbitted, ring-oiling, dustproof bearing incorporated rigidly as part of the motor frame. This replaces the picker bearing and is bolted on through the same holes as were previously used. The motor rests on an adjustable stand, shown in the photographs, and the bearing is supported on the usual shelf provided for the picker bearing. Thus the alignment of stator and rotor is fixed and permanent, and the installation becomes a very simple matter. The bearing is made to fit any of the standard makes of pickers and will be used in all future installations.

The direct-connected drive is so eminently desirable that it is expected that it will be applied more generally as time goes on. In conversation recently with the "road man" of one of the leading manufacturers of pickers the writer was informed that the tendency, both North and South, is very markedly toward lower speeds on the beaters, 1,000 turns being now much more common than it was five years ago, and 1,400 turns correspondingly more rare. It is found that the higher speeds damage the fibres without effecting any greater cleaning. It is possible to beat the cotton so fast that the dust has time to fall through the slots, but is carried on with the fibres to the screens and lap rolls. This tendency toward lower speeds will greatly accelerate the adoption of the direct drive with motors of 1,150 revolutions per minute.

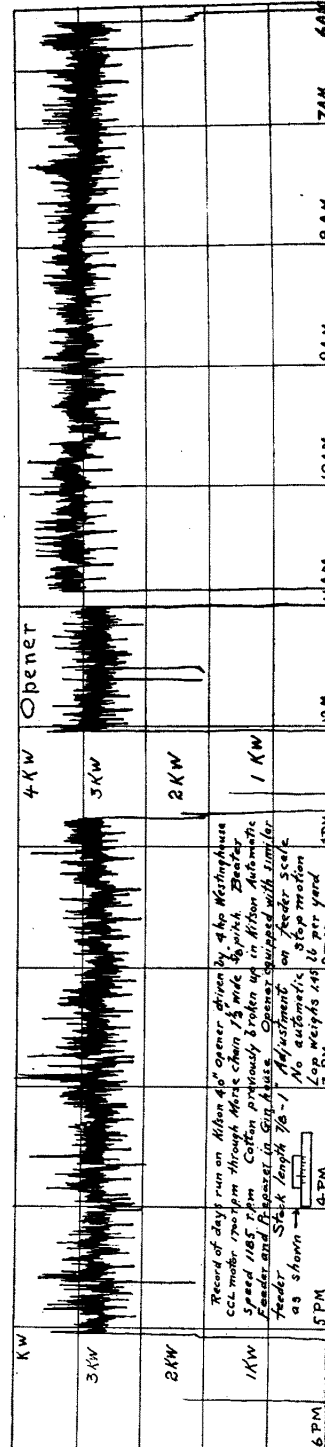

POWER RECORD OF KILTON BREAKER WITH AUTOMATIC FEEDER DRIVEN BY WESTINGHOUSE MOTOR

One interesting feature of the development of the individual drive for picking machinery has been the affording of an opportunity to secure what it pleases our fancy to designate as "inside information," by which we mean reliable data as to what is going on within the machine. This is an item previously impossible to get at. It cannot be secured from a group of machines because the averaging effect of this method hides the individual characteristics of each machine. A power scale is too uncertain and even the usual indicating wattmeter, with a test motor, gives only an inkling of the fluctuations. The accompanying curves were drawn by a Westinghouse graphic recording wattmeter and show accurately, and in detail, the power of three stages of the picking process, the breaker with automatic feeder, the intermediate and the finisher.

DISCUSSION OF CURVES.

The breaker curve records the power history of a Westinghouse 5-horse-power motor driving through a Morse silent chain to the beater shaft of a 40-inch Kitson breaker lapper with automatic feeder and preparer. It is a machine with one three-bladed beater, with one fan and one cage section, and a lap-head for a 40-inch lap. The automatic "stop-motion" was disconnected, the feeding being uninterrupted and the lap being allowed to roll up until removed by the attendant.

The chart represents the run of an entire day, the heavy vertical lines denoting the hours as marked at the bottom, the fine horizontal lines showing the scale of power taken by the motor. It will be noted that the motor was started about 6.07 A. M., and that for about three minutes the power required was only about 1.8 kilowatts while the motor was running only the fan and the beater. When the feed was started and the beater began to break up the cotton the power rose to about 3 kilowatts. Immediately an irregular fluctuation

set in, due to the irregularity in the amount of cotton fed to the beater and the toughness of the masses. The feed was shut off for an instant at 6.20, but was quickly started again. It then ran continuously until 10.42, when the motor was stopped for eight minutes to make adjustments. The feed was stopped twice between 11 and noon. At 12.42 the motor was again started and the feed thrown on at 12.45. In the afternoon the feed was stopped three times, but the motor ran until 5.03 P. M., when it was shut down for the day.

It is noticeable that at more or less regular intervals the power is reduced below the average, as shown by the lines projecting below the broad band of the record. This was caused by the removal of the lap, when the attendant judged it was large enough to be taken off. To do this the pressure under which the lap is being wound is momentarily released. The mandrel on which the new lap is to be wound is then placed on the outcoming sheet of cotton and the pressure again applied while the new lap is forming. The feed is not stopped to do this.

At 6.15, 7.20, 2.50 and 4.35 the cotton came through in compact masses for a short interval and caused the power required to increase correspondingly.

The intermediate picker record is the power history of a 7.5-horse-power Westinghouse CCL motor, driving through a belt from the pulley of a motor on the ceiling to the pulley on the beater shaft of a 40-inch Kitson intermediate lapper. It is a one-beater machine, the beater being a two-bladed one, and there is but one exhaust fan belting from the beater shaft, and one cage section and a lap head for a 40-inch lap. The automatic stop motion was used and operated at eight-minute intervals, winding a lap 48 yards long, weighing 50.6 pounds. The beater speed was 1,470 revolutions per minute. The machine was supplied

with an evener, a cone pulley and sliding-belt device operated by a row of broad fingers pressing on the sheet of cotton as it passes into the beater box and designed to proportion the rate of feed inversely to the thickness of the sheet being fed, so as to make constant the quantity of cotton per unit of time.

The record shows that the motor and picker were started at 6.09 A. M., and that in eight minutes a 48-yard lap was completed and the stop motion cut off the feed automatically. The attendant was waiting, however, and removed the lap at once and immediately started the feed, so that the machine was running idle but a few seconds. A little after 7 A. M., it will be noticed, the power curve becomes more erratic, and at 7.15 and 7.25 the feed was shut off for three or four minutes instead of as many seconds. This was because the evener belt was slipping, causing uneven thickness of cotton to pass to the beater with a corresponding reduction in speed. The heavier the masses the beater has to break up the more power required. The longer stops between laps were necessitated by the time consumed in trying to adjust matters. The trouble, however, continued throughout the day in spite of several attempts to fix it, as indicated by the raggedness of the curve and by the long stops at 8.45 and 5.15, and the shorter periods at more frequent intervals.

The curve shows that, owing to a press of orders, the mill was run overtime the day of this test, and a third session of from 7 to 9.15 added to the already long day. By this record it is possible to count the number of laps rolled up and the percent of total working time the machine was operating. It shows that seventy-two laps were formed in the two regular sessions and fifteen at night, and that the picker was working 88.4 per cent. of the time the motor was running.

The power record of the finisher

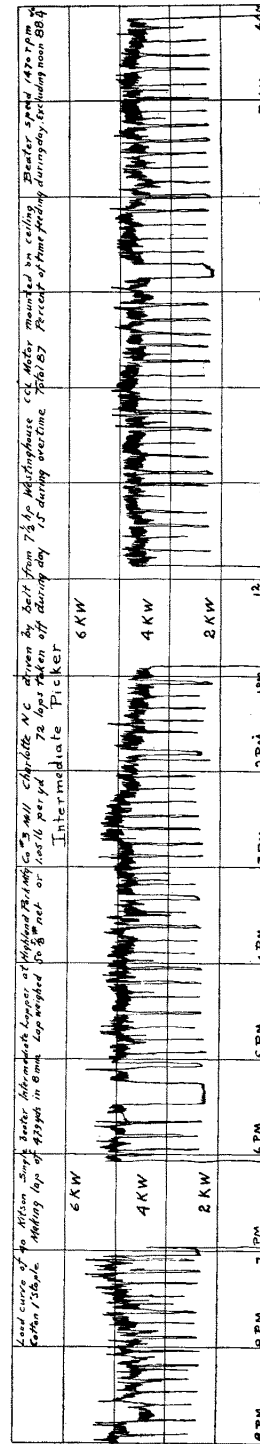

RECORD OF POWER CONSUMED BY KITSON INTERMEDIATE PICKER DRIVEN BY WESTINGHOUSE MOTOR

picker is the history of a day's run of a 5-horse-power Westinghouse type CCL motor, driving through a Morse silent chain a Kitson finisher picker, similar to the intermediate picker just described in all respects except the beater. The two-bladed beater is replaced here by a three-armed carding beater, which has in place of blades heavy wooden bases for rows of spikes, about $\frac{3}{4}$ inches long, which pull the cotton apart rather than beat it as in the earlier stages. A 48-yard lap, weighing 42.5 pounds, was rolled on this machine in practically eight minutes. The action of the stop motion at the completion of each lap is clearly shown as in the previous case. At 3.30 the small evener belt began to stick and give trouble, and this was not fixed for two laps. Otherwise the record is quite regular.

In frequent instances the attendant would not place a lap on the feed apron as soon as it was needed, and for a short interval only a three-ply sheet was going in instead of a four-ply. The evener would do its utmost to correct for this by speeding up the apron, but even if the amount of cotton were maintained constant, the thickness of the sheet was less and offered less resistance to the beater blades, so that the power fell off very noticeably until the cotton from the new lap again restored normal conditions. This condition of affairs is recorded, for example, at 9.35 A. M., and again at 2.47 P. M. At both these times the interval was about a minute and a half, and the finished lap was probably deficient because of it.

It is interesting to observe how closely such an instrument records all the happenings of a day in this way. In a picker room, where production is being crowded, a meter record, taken by the card-room overseer on any machine in the room, the connection being made without the knowledge of the hands, will show him a great deal about where improvements can be made. It keeps

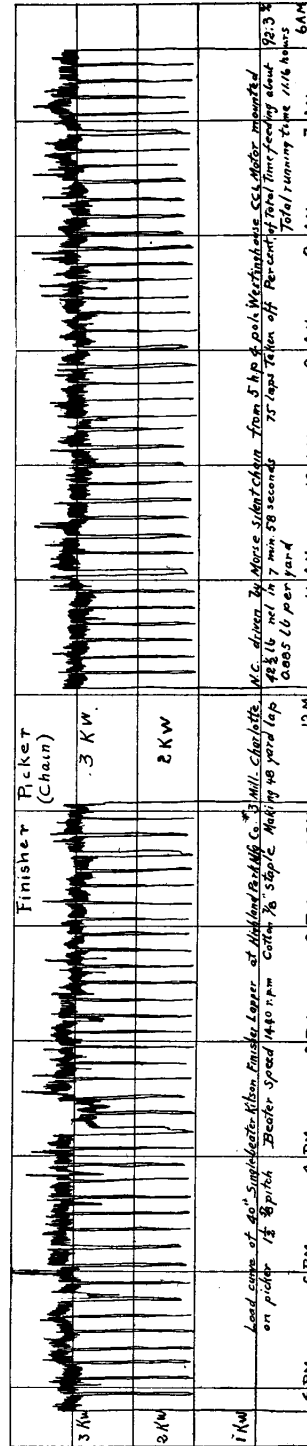

LOAD CURVE MADE BY WESTINGHOUSE GRAPHIC METER, SHOWING POWER RECORD OF FINISHER PICKER

tabs on the operatives no less than on the machine.

GENERAL SUMMARY

The development of the induction motor to its present efficiency, and at its present low cost, has been the strongest factor influencing the adoption of individual drive in all lines of industry. Its spread to the cotton mill is most logical. The machines are of high rotative speed, and production is an item of supreme importance and is affected materially by the regularity of these speeds. Pulsations or variations are detrimental to the product, but are ineradicable with an engine and belt system. It has been well stated by an engineer who asserts that the benefits of electric drive increase proportionately as the motor is brought nearer to direct connection to the machine. The picker room is the most advantageous department in which to make an installation of this sort, and the development of the drive has been watched with more than ordinary interest, keen rivalry

having developed among both the electric companies and the various mills, many strong partisans having voiced their opinions for and against each method as it has been put in operation. It is our personal opinion that the direct drive will ultimately be most favored, though probably not in the exact form now used. As new machines are developed, provision for a more mechanical attachment will be made than can be provided when attempting to utilize old parts. Dust-proof bearings will be used throughout, or possibly some form of flexible coupling, with two bearings on the motor, retaining the present rough iron bearings on the machines. Improvements in details will continue to appear until the final evolution will make the first installation appear very crude. This development has already taken place in the driving of spinning frames and twistors, and the direct-connected motor has replaced all other forms of motor drive and is held in high esteem. We predict as successful a future for it in the picker room.