

FROM WOODS & FIELDS

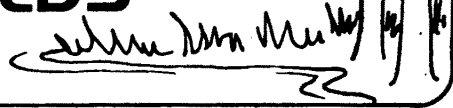

by Connie Magoffin

Fred Gerber has written a new 70-page book entitled, *Cochineal and the Insect Dyes*. In the past a lot has been written about cochineal, but of the sources available to me, Mr. Gerber has offered much more, including both historical and practical information. The first part of the book begins with a brief historical overview of dyes and mordants. Then follows a discussion of the insect dyes including kermes, St. John's Blood, lac and, finally, a detailed look at cochineal.

In the middle of the book is a colorful insert upon which is mounted 34 different yarn samples dyed with cochineal, each representing a different mordant, a combination of mordants, different modifiers (particularly different acids) or different exhaust baths. Gerber continues with a review of Bancroft's detailed study of cochineal which was begun in 1786. He also explains the difference between unmodified cochineal and carmine cochineal and how you can make your own carmine cochineal.

The next section of the book I was very happy to read. I have long looked for a practical color notation

system to use for recording my dye sample colors. Gerber suggests a new one to me, the ISCC-NBS Color Name Charts Illustrated with Centroid Colors from the National Bureau of Standards, Washington, D.C. He uses it to notate his cochineal studies and I plan to explore its possibilities. It would be nice if we could have a common terminology of color.

Gerber spends 10 pages explaining his series of cochineal experiments and making observations on the results. It is frustrating that not all of the experiments he discusses are included in the yarn samples, however, the 34 he does include are more than generous and they are extremely helpful in suggesting the enormous color potential of cochineal. The book is concluded and on the last page Mr. Gerber offers a question for modern dye experts to answer concerning the antiquity of the use of cochineal on the old world. Fred Gerber's book gave me a new understanding of a traditional dye-stuff and opened new avenues for exploration with cochineal. He has also done such extensive personal experimentation, Mr. Gerber offers insights you seldom find in current dyebooks.

Anyone who dyes with cochineal should have this book. If you are interested, write Gerber Publications And The Arachnid, P.O. Box 1355, Ormond Beach, Florida 32074. The book is \$6.75, plus postage, however, he offers a 40% discount for 6 or more copies (if several of you want to get together). The postage for 3 books or less is \$.50.

Glimåkra Looms.

From four harness

to Damask Looms.

Steady, Sturdy, Swedish.

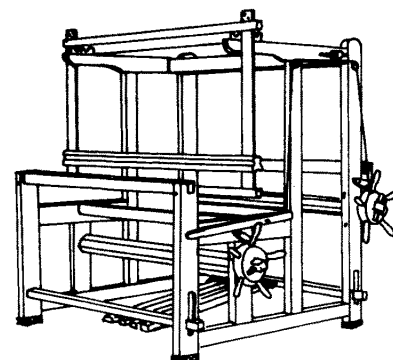
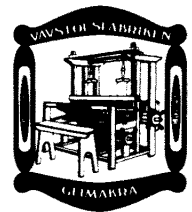

M. Susan Brock Ltd.

1838 St. Clair Ave.

St. Paul, Minnesota 55105

tel. 612/699-1909