

Dictionary of Technical Terms Relating to the Textile Industry.

(Continued from page 74.)

SPOTTING:—Weaving spots; planning spot designs; swivel weaving.

SPRAYING:—Damping fabrics automatically by ma-

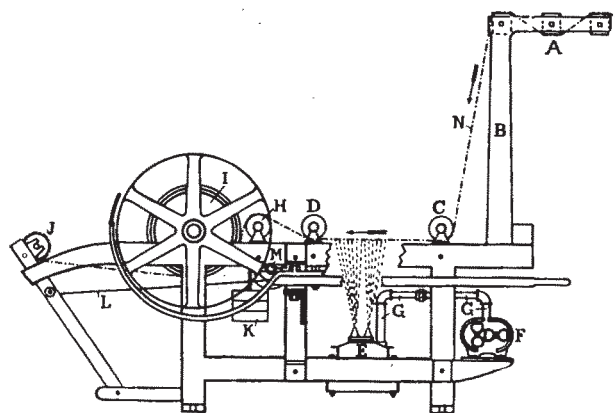

SPRAYING MACHINE.

The Textile-Finishing Machinery Co.

A, Feed; B, Uprights; C, D, Guide Rollers; E, Atomizer; F, Air Pressure Pump and G connection between both; H, Stretching Roller; I, Drum; J, Cloth Roller; K, Weight; L, Strap; M, Shaft.

chinery by means of the finest possible spray of water in the process of finishing certain (cotton) fabrics.

SPREAD-BOARD:—Upon its table the flax fibres are spread in even layers, producing a continuous bunch of about the same thickness. The spread flax passes between the vertical partitions at the end of the table and connecting with the machine to a pair of rollers. A second system of rollers in turn takes the flax from the first set. The

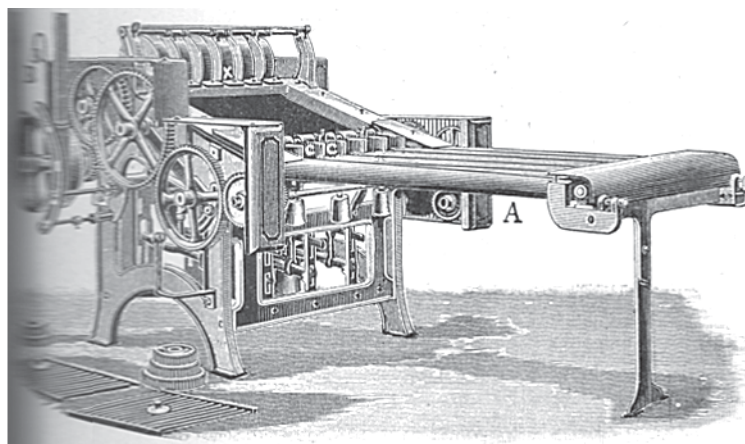

SPREAD-BOARD.

A, Feed tabl; B, Bell which rings when a certain length of sliver (from 300 to 2000 yards) has been delivered into the sliver can. C, vertical partitions.

bunches of flax, spread on the feeding-table of the spread-board, are stretched or drawn out by means of two pairs of rollers, called feed and delivery rollers respectively, and are mixed in a solid, continuous sliver, by means of the gills of the fallers. The spread-board is capable of spreading, drawing, stretching, or extending the bunches of flax to from 25 to 40 times their original length. Refers also to Jute.

SPRING TAKE-UP:—An elastic finger which takes up the slack of the yarn on knitting, winding, etc., machinery.

SPUN GLASS:—When a glass rod is heated in a flame until perfectly soft, it can be drawn out in the form of very fine threads, and is used in the production of novelties, or for special fabrics. Spun glass can be produced in colors; but, on account of the low elasticity of these products, their practical value is small, though the threads are exceedingly uniform and have beautiful luster. Spun glass structures are used as a substance for filtering strong acid solutions. A curly kind of glass wool is produced by drawing out two glass rods of different degrees of hardness to a capillary thread. On cooling, they curl up in consequence of the different construction of the two constituent threads.

SPUN-GOLD:—Gold thread for weaving special ornamental fabrics, particularly that made by twisting or wrapping a very thin narrow ribbon of rolled gold about a cotton or silk thread.

SPUN SILK:—Silk thread produced from cocoons which the insect has pierced in eating its way out; floss, husks or waste from reeling, *i. e.*, silk which is too much entangled and cannot be commercially reeled; also waste silk made in throwing and weaving.

A yarn composed of fibres of silk, which fibres have been cut or dressed into lengths to enable it to be spun.

SPUN SILVER:—Silver thread for weaving special ornamental fabrics; particularly that made by twisting or wrapping a very thin narrow ribbon of rolled silver about a cotton or silk thread.

SPYNDLE:—The largest standard measure of yarn. 14,400 yards in length.

SQUIRRELS:—A name sometimes given to the workers of a carding engine.

STACKING:—When roughing, in preparing flax for the mill, is found too expensive a process, stacking is substituted; *i. e.*, piecing the flax in double pieces, straightening out their length, next opening on the hackle and breaking the root ends. Stacking is done by boys, whereas roughing is men's work.

STAINED COTTON:—Cotton fibres which in the field have been exposed to frost, with the result that the fibre is colored a pale buff. It is not so valuable as carefully cultivated (white) cotton.

STAINED WOOL:—Wool which has become discolored through the effects of urine, etc. When scoured, it has a burnt appearance. Used in making goods of dark color.

STAINED YARN:—May be caused by the working-up of stained cotton, but is chiefly due to carelessness of the mill operatives in allowing oil to come into contact with the yarn. Is also often caused by a broken thread not receiving immediate attention, and striking some part of the machine, thus picking up grease and dirt. This, it conveys to its neighbor when pieced-up. Stained yarn may sometimes arise from operatives having dirty hands, or from impure water when the doubling is done on the *wet* principle.

STAKE-HEADS:—Posts at the side of the rope-walk for supporting the laid rope.

STANDARD:—The number of yards used as a basis for grading the counts or numbers of yarn. Cotton yarns have for their standard 840 yards (equal to 1 hank) and are graded by the number of hanks one pound contains. Worsted yarns have for their standard 560 yards to the hank. Woolen yarns are graded either by the run or the cut system; the former has for its standard 1,600 yards, the latter 300 yards. Silk yarns refer either to spun silks, which have the same standard as cotton, or to raw silks, where the adopted custom is to specify the size by giving the weight of a 1000 yards hank in drams avoirdupois, or they are graded by the denier system. Linen, Jute or Ramie yarns have for their standard 300 yards to the hank or lea.

STANDARD COLORS:—Those of the spectrum.

STANDARD-HARNES:—In gauze or leno weaving one of the doup harnesses, the harness-frame or heddle to which the doup is threaded.

STANDARD-THREAD:—In gauze weaving, the thread or

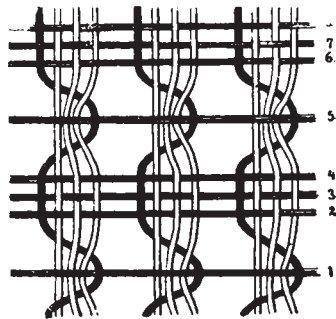

DIAGRAM SHOWING STANDARD THREADS.
One Whip-thread (shown in black) twisting around three Standard threads (shown in outlines) every fourth pick.

the threads, around which the whip-thread or threads twist.

STANDS:—Refers to cotton growing; a group of the best plants which is allowed to go forward in its growth after the rest have been chopped or weeded out; stands are separated by due distances from each other, about a foot being allowed on high land, while those on low land, where the growth is more luxuriant, are left at distances of from eighteen to twenty inches.

STANNATE OF SODA:—A salt made up of stannic oxide dissolved in a solution of caustic soda, used in printing steam colors; also known as *Stannate of Sodium*.

STANNIC CHLORIDE:—A salt obtained by treating tin crystals with hydrochloric acid and chlorate of soda.

STANNIC OXALATE:—A tin salt used in steam colors, and obtained by dissolving stannic chloride in oxalic acid.

STANNIC OXIDE:—Produced by adding carbonate of soda to stannic chloride, and used for making stannate of soda.

STANNOUS ACETATE:—A chemical, useful in the discharge style of calico printing, made by mixing together solutions of stannic chloride and acetate of lead.

STAPLE:—A group or lock of fibres.

To sort or classify any fibre according to its length and strength.

The tuft, bundle, or lock of wool fibres which, although growing separately on the body of the sheep, owing to their wavy or crimply nature, cling together and form themselves into locks on the back of the sheep.

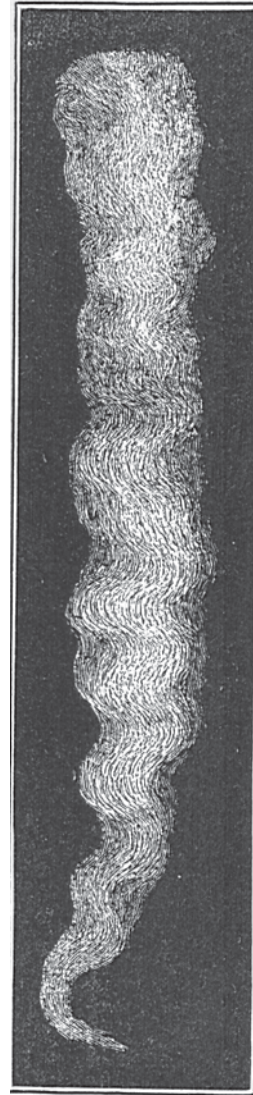

STAPLE.
A Lock of Wool Fibres.

Sea Island cotton is a long-stapled cotton, Upland a short-stapled cotton. Formerly worsted yarn called for a long staple wool, whereas clothing or such wools as referred to woolen spinning, called for a short staple, but which is no longer the case, on account of improved machinery invented since then for combing the latter.

STAPLER:—A merchant who buys wool and sorts it into its various qualities for the manufacturer.

STARCH:—One of the most important of the materials used by the finisher of cotton goods, and in one or the other of its varieties enters into the composition of nearly all finishing mixtures. It is also used in the sizing of cotton warps, to insure better weaving.

Starch belongs to the class of carbo-hydrates. It is essentially a vegetable production, being found to a greater or less extent in all plants, especially in the seeds, roots and stems.