

## FABRIC ANALYSIS.

Testing for Counts.

TESTING STRENGTH AND STRETCH OF SINGLE THREADS.

(Continued from March issue.)

Fig. 67 shows the Strength and Elasticity Testing Apparatus as built by Chas. H. Knapp of Paterson, N. J. This instrument gives the tensile strength of the thread expressed

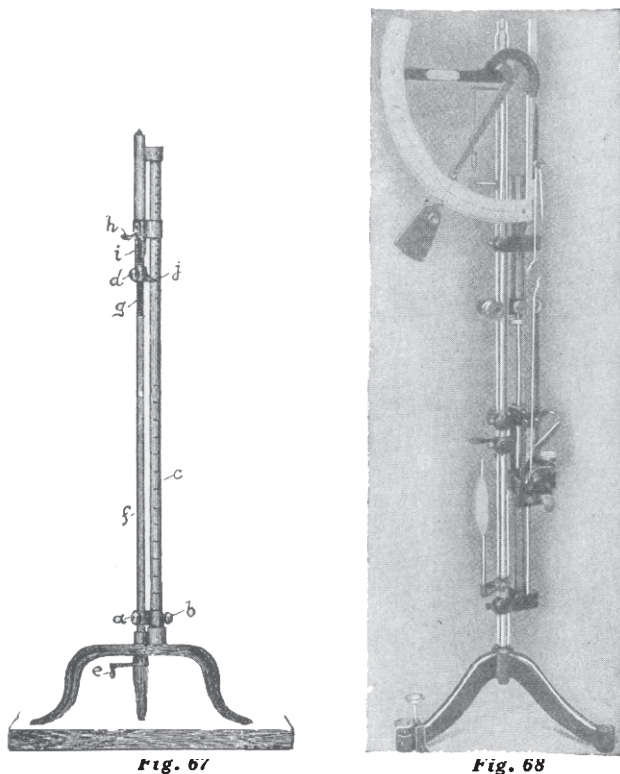

in quarter ounces and the elasticity in tenths of inches. Its capacity is one pound tensile strength, and sixth inches elongation, permitting the testing of a thread from six to eighteen inches long. The working of the apparatus is thus: After setting clamp *a*, by means of screw knob *b*, in the proper distance on (scale) rod *c* to suit the length of thread to be tested, place the two ends of your thread securely between clamps *a* and *d* respectively. By turning handle *e*, rod *f* is simultaneously turned and which by means of its screw portion *g* raises catch *d* and thus puts tension on the thread tested, until the same breaks. *h* is a handle catch, engaging in a notch rock that holds the notched sliding rod *i* in place when the thread breaks. Each notch equals one quarter ( $\frac{1}{4}$ ) oz., hence handle catch *h* shows tensile strength of thread in quarter ounces. Pointer *j* shows on rod *c* the elasticity of the thread tested.

A Single Strand Strength and Elasticity Tester, with oil tank controlled pull is shown in its perspective view in Fig. 68; the same is built by Henry Baer & Co., Zurich, Switzerland, and sold in this country by Alfred Suter, New York. Fig. 69 is a diagram of this tester, being given to better explain the working of the apparatus, giving also a detail drawing showing how the speed of the plunger is regulated, and all vibration during the test eliminated.

The action of the machine is somewhat as follows: A thread is looped over a small pulley at *B*, and the two ends are held by a screw clip at *S*. This is attached to a frame which, when the apparatus is at rest is held up by a catch *K*. This frame carries a perforated plunger *F* working in an oil cylinder *E*; the upper part *D* of the plunger terminates in a lead weight covered with brass. The quadrant and arm *G, G'*, carry a pair of catches and a weight *J*, which latter supplies the necessary strain required to break the yarn.

When a test has to be made, the arm *G'* is brought down, and a square catch *L'* takes into the detent *L* until the thread is placed in position as mentioned. *L'* is now lowered, and catch *K* lifted, which allows the frame to descend and

put strain on the yarn; the weight *J* is slowly raised until the thread breaks and when the load is shown on the quadrant. While the frame descends, and the thread is still unbroken, the graduated scale *M* descends at the same speed, but as soon as the thread breaks the scale is released and stops, and the elongation is shown on the scale by the pointer *N*, which is connected with *B* and consequently comes down at the same rate.

The machines are provided with two scales on the quadrant, one having a range of sixteen ounces, and the other a range of four pounds; for the finer yarns, the front portion of the weight is removed and when then the break is read on the upper or sixteen ounce scale. The speed of the plunger is set to one inch in five seconds by regulating the aperture through which the oil flows.

In practice a double thread test will be found convenient, and a large number of tests can be made in a short time. The length of yarn tested is 18 inches for single and 36 inches for double thread tests.

Another Strength and Elasticity Tester is shown in its perspective view in Fig. 70, the same (similarly to the apparatus previously described) operating also with oil controlled pull.

The procedure of testing by this apparatus is thus: Insert your thread between clamps *c* and *c'* being careful that the catch lever with its thumb *d* rests upon pivot *e* so that when the piston *f* is lowered, scale *i* is simultaneously lowered.

When the thread tested breaks, said catch lever simultaneously tips over and scale *i* then remains at rest. Arm *b* then has locked itself to the sextant *a*, showing the breaking strength of the thread, on its scale, whereas pointer *h* shows the elasticity of the thread on scale *i*.

### SPECIAL TESTING APPARATUS FOR RAW, THROWN, SPUN, AND ARTIFICIAL SILK, ETC.

Fig. 71 shows in its perspective view such an apparatus as used extensively in the silk industry of the European Continent and which from data given previously will explain itself.

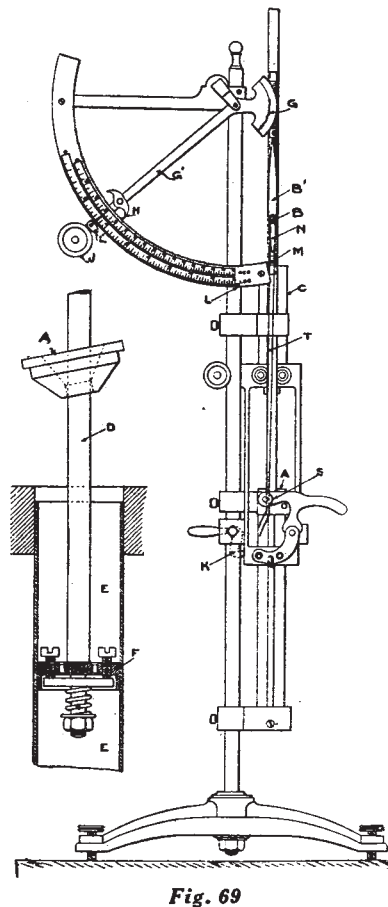

The apparatus comprises two adjustable reels each holding one silk skein to be tested. Each end of the latter then passes through a guide-eye, a series of four glass rods placed

one above the other so as to impart the required tension to the thread, which then passes through another guide-eye and onto the reel to which motion is imparted by hand. The

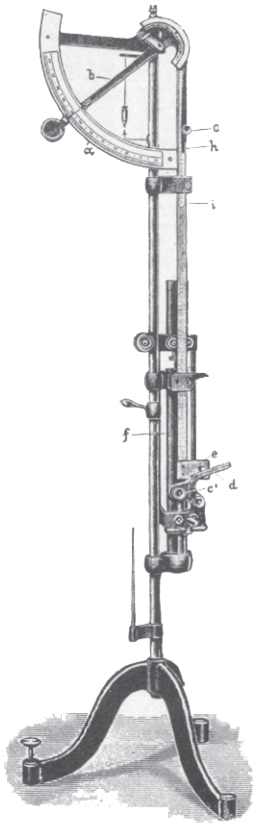

Fig. 70

latter is secured to the lower section of the stand carrying the Sizing Balance or Quadrant for weighing the skein. The complete apparatus is secured to a hardwood case.

A CONTINUOUS-ACTING STRENGTH TESTER.

Fig. 72 shows this apparatus in its perspective view, the work of which consists in testing a cop, bobbin or skein of

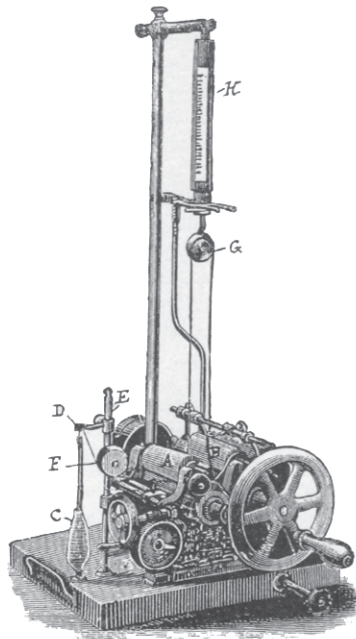

Fig. 72

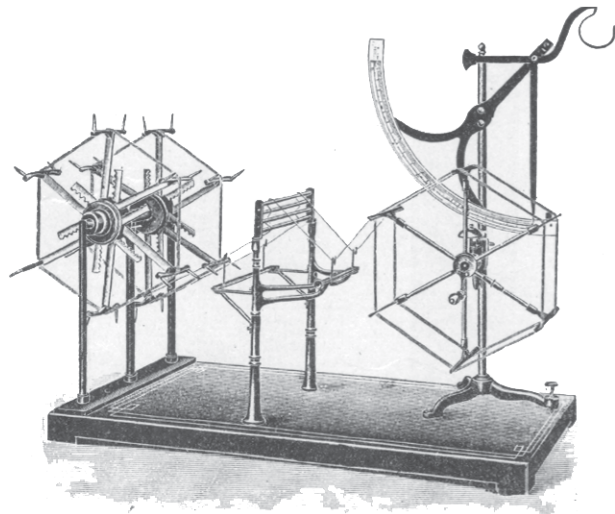

Fig. 71

yarn throughout its entire length, i. e., to ascertain a fair average of the maximum stretch the yarn can be subjected to without causing unnecessary breakage. The procedure of testing by this apparatus is thus: The yarn as coming from the bobbin C then passes through guide-eye D, secured to stand E, then partly around guide roller F to and between the bite of a pair of conical rollers A, from which the thread

then passes over a pulley G, secured to the spring dynamometer (spring scale) H, then to and through the bite of two rollers B, and in turn laid onto a roller, covered with plush (not shown). By means of using movable thread guides the tension on the thread can be regulated, being read off from the scale of the spring dynamometer H and from which information tension can be regulated to suit requirements of the yarn. The apparatus may be driven either by hand or power, its surface speed being 15m. (about 16½ yards) per minute.

In some testing apparatuses water is adopted as the means of obtaining the load required for breaking the thread; a graduated vessel, into which the water is poured, gives the weight in grammes or ounces. The stretch of the thread is recorded by means of a pointer, which is attached to the sliding jaw, on a scale divided into fiftieths of an inch.

When making tests, no matter what apparatus is used, note should be taken as to whether the breakage of the thread causes a clear fracture of the fibres, as in an uneven thread the fibres may be liable to slip from each other in the thick parts. Ten or twenty tests should be made from as many bobbins or hanks taken at random from the lot, and the average found; at the same time a note should be made of the amount of variation. Other things being equal, the quality and holding power of the fibres of which a thread is composed, as well as the evenness of the thread, will be indicated by the results of tests for strength and stretch.

Although this method of testing a single or double thread is the one most commonly practised by spinners, it is thought by some not to give the best average results, inasmuch as the strength of the stronger threads is not taken into account, and possibly only a percentage of the weaker ones. What the test gives, they claim, is merely the approximate strength of an unknown quantity of weaker threads. This gave rise to the introduction in the United States of the *Moscrop Tester* by the Draper Corporation, Hopedale, Mass.

The action of the machine may be gathered from the following description: The cops or bobbins are placed on skewers mounted upon a frame having a traversing motion, each thread being passed through the tensioning hooks and eyes, and between a clip.

When the machine is started the frame moves forward, and a plate lying underneath the threads rises and lays each thread into the jaws of another series of clips which immediately close. When the frame or carriage has receded about 12 inches, the clips in the carriage close on the threads, and as the carriage continues its outward movement for about another 4 inches strain is put on the threads, and which strain distends a series of springs mounted at the rear end of the second set of clips. This distension draws a series of pointers along until the several threads are broken, then the pointers are pressed down into the diagram slip, at the positions to which the pointers have been pulled, and thus a record of the breaking load is made.

The broken ends are then cleared away from the clips, the pointers pushed back to zero and the whole cycle of movements is repeated about eighty times, when the machine is stopped automatically. The record of the breaking strength of the several threads is shown on a punctured slip, and the variations are readily observed.

Different strengths of springs are used for various qualities and counts of yarn. The only apparently weak part of the machine is the springs, and to eliminate error, the greatest possible care must be exercised in the selection of these springs.

(To be continued.)

British Requisition of Russian Flax.

Unusually heavy linen shipments for this period have been made from the Dunfermline constular district to the United States within the past six weeks, largely in anticipation, it is said, of the Army Council notice that appeared in the Army Gazette for March 16. This notice states that the Government will take possession of all the Russian flax and tow in stock in the United Kingdom not already sold to spinners in the United Kingdom, except where a permit of sale has been issued, and that it intends to take possession of all Russian flax and tow which may hereafter arrive in the United Kingdom.