

Leno Weaving and Design

By W. E. SHINN and A. E. McKENNA, CLEMSON COLLEGE, S. C.

(Continued from April issue, p. 36)

Fancy Allover Effects. Patterns similar to intersection drawing, Fig. 10A, may be obtained by the use of more than one ground harness. The end lettered (D) is the doup end and is shown crossing under the two ground ends, first to one side and then to the other. Figs. 10B and 10C show the corresponding drawing-in and chain drafts. Other allover effects may be obtained by using additional doups sets and ground harnesses. With the addition of two separate ground harnesses in place of the two used in the second set of doups, as shown in the drawing-in draft, Fig.

10B, a new pattern may be obtained as shown in Fig. 11. It will be noted that each group of three ends form their crossings on different picks, thus necessitating the use of separate slackener motions for each group.

Other interesting patterns may be formed in a similar manner by varying the method of reeding in combination with right- and left-hand doups. By using two beams in fabrics of this type, in which the ground ends are under considerably more tension than the doup ends, cellular effects with wavy lines and open spaces may be obtained.

Figured Effects with Plain Weave. Patterns of a combination of plain weave and leno, in which the figure is formed with small sections of plain weave, may be woven with an arrange-

easier and with fewer harnesses. Patterns woven with the slotted doup will be shown in another section of this article.

Clipped Spot Patterns. Spotted figure effects may be obtained on box looms by tying-in soft roving yarn at intervals in the leno

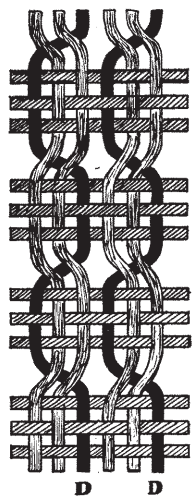

Figure 10a
Diagram of Three-End
Leno Weave

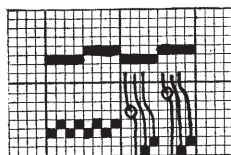

Figure 10b
Drawing-In Draft

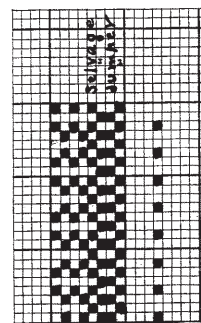

Figure 10c
Chain Draft

ment of plain steel doups and cord doups. In Fig. 12, the design in three-end leno was woven on a set of cord doups with pattern harnesses for each change in the pattern; steel doups be-

fabric. The cloth from the loom is passed through a shearing machine where the long floats between the points of stitching are cut off. Fig. 13A illustrates a fabric of this type

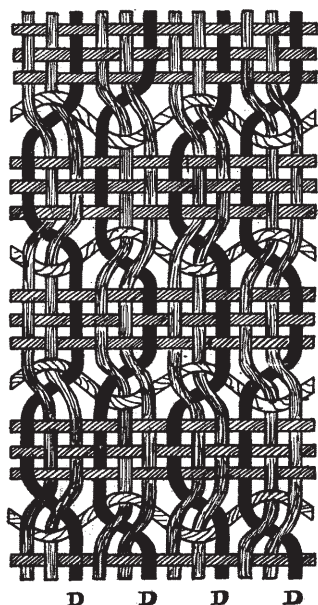

Figure 11
Diagram of Fancy Three-End Leno Weave

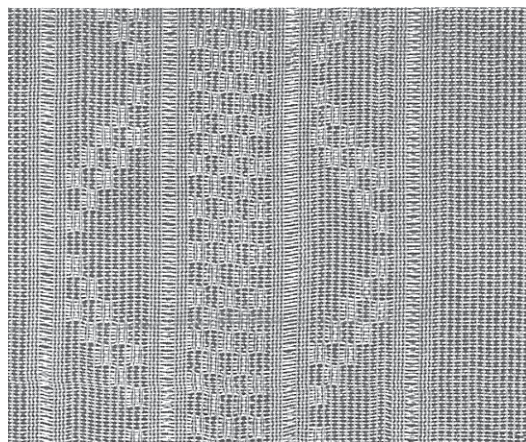

Figure 12
Figured Leno Fabric

ing used for the plain leno ground. The invention of the slotted doup has enabled mills to weave patterns of figured three-end leno

with small figures arranged in alternate or staggered formation. Figs. 13B and 13C show the corresponding drawing-in and chain drafts. Two sets of doups and nine pattern harnesses were used for this fabric. The doup end was first drawn through an offset heddle (eye located below center) which is used as an easer and operated by the jumper motion. All

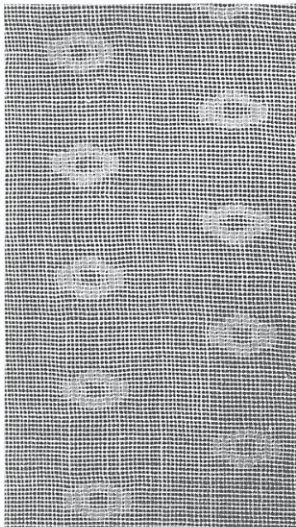

Figure 13a
Clipped Spot on Plain Leno Ground

Figure 13b
Drawing-In Draft

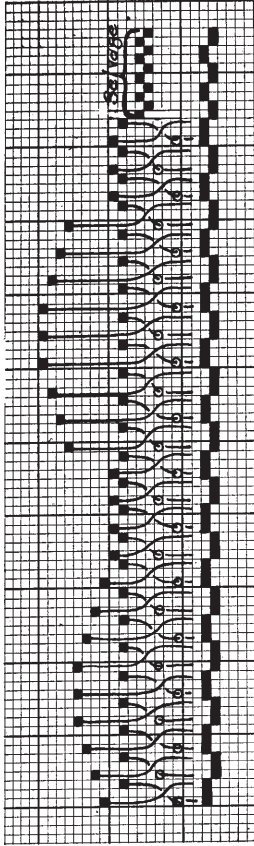

Figure 13c
Chain Draft

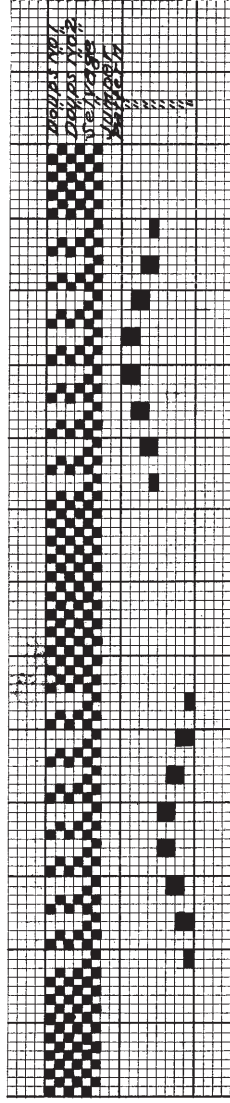

Figure 14a
Clipped Spot on Plain
Leno Ground

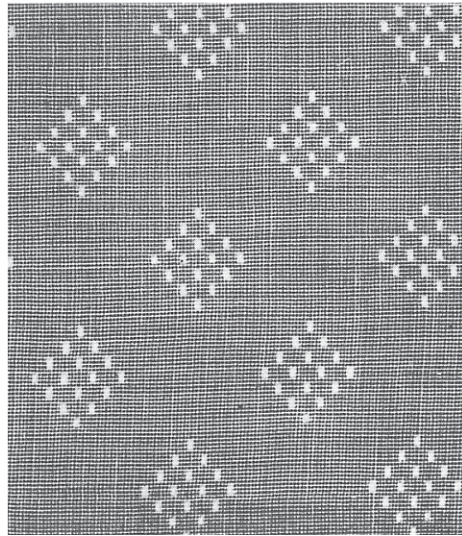

Figure 14c
Chain Draft

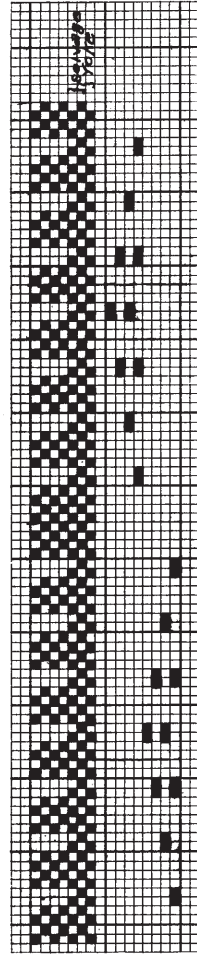
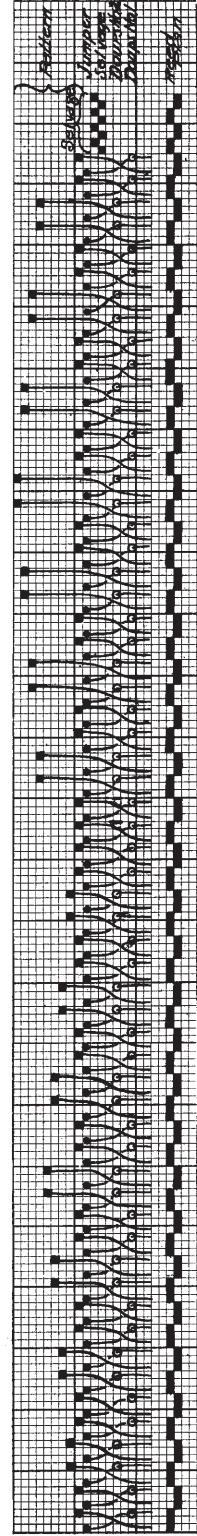

Figure 14b
Drawing-In Draft



pattern harnesses must be jumped on each pick and a strong, well-built mechanism must be used for this type of work. Where the roving is to be tied-in, a pattern harness used to produce this spot is raised from the center to the top of the shed, while all of the other pattern harnesses and doups remain down.

Fig. 14A illustrates another clipped spot pattern in which small spots of roving are woven in diamond formation. Figs. 14B and 14C show the corresponding drawing-in and chain drafts. It will be noted in the drawing-in draft that, contrary to the usual custom, a left-hand doup was used.

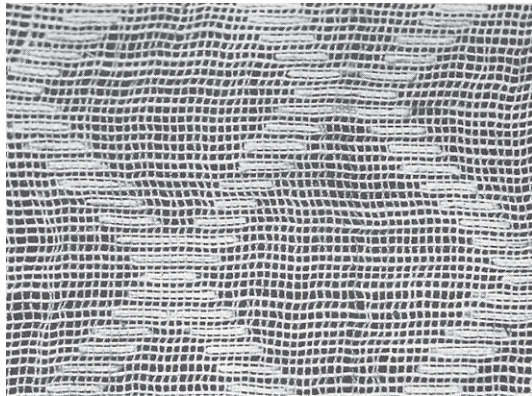

Figure 15a
Diamond Pattern Formed with Extra Filling on
a Plain Leno Ground

Fig. 15A illustrates a large clipped spot pattern woven in coarse yarn. This fabric, as will be noted by the drawing-in and chain drafts, Figs. 15B and 15C, was woven by a different method from that used in the preceding clipped spot fabrics. Fig. 16 demonstrates the arrangement for weaving this pattern. The doup end (c) is drawn through an offset heddle (h) before being passed through the eye of the doup (a) and, in place of being operated by the jumper motion, is raised from the middle of the shed to the top of the shed each pick by a double yoke. The ground end (f), after being passed through the pattern heddle (g), is drawn through a slotted heddle (j). The slotted heddle is operated by the jumper motion and its object is to raise the pattern end to the center of the shed each pick to allow the doup end to cross under it.

The use of slotted heddles makes it unnecessary to jump the pattern harnesses to obtain a crossing and this arrangement is a considerable improvement over the method used for the first two clip spot samples. In the formation of plain weave for tying-in the roving filling, the long space in the slotted heddle allows ample room for the elevation of the pattern ends. A double yoke for the operation of the offset heddles is shown in Fig. 17. This yoke is inserted between the harness levers which work

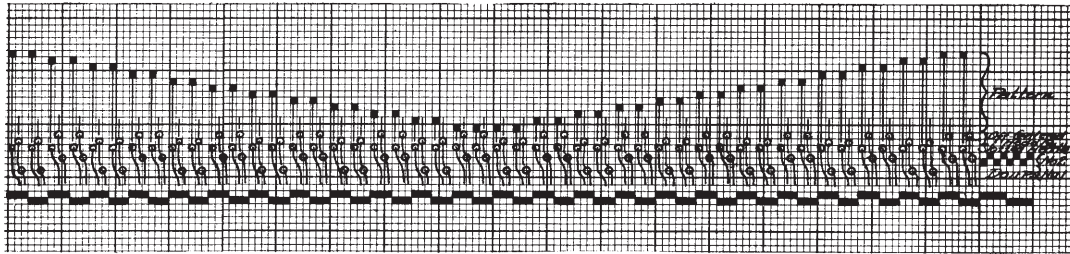

Figure 15b
Drawing-In Draft

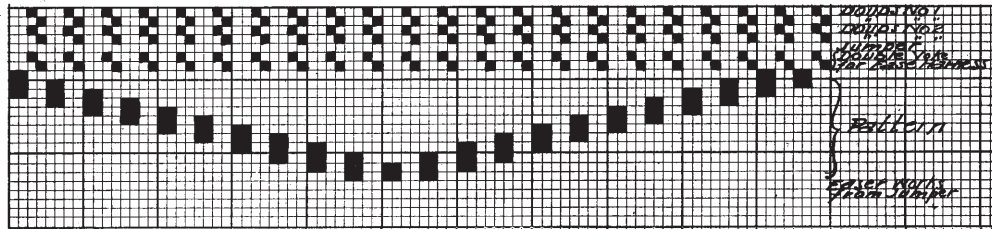

Figure 15c
Chain Draft

in the loops marked (a) and (b), and the levers are operated in plain weave order. The slackener motion (k), which works in unison with the slotted heddles is operated by the jumper mechanism.

Some method must be used in weaving these fabrics to catch the roving filling at the edges of the cloth. Usually a catch cord of several ends of heavy cord is used for this purpose. However, probably the best arrangement

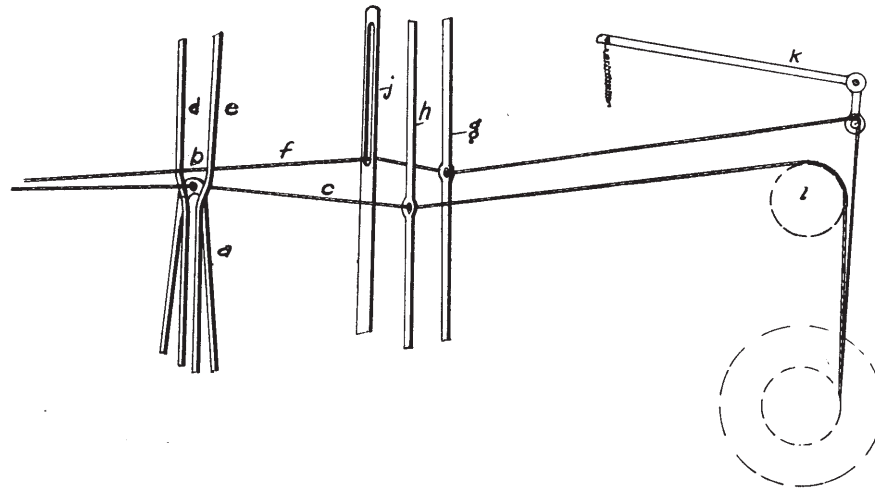

Figure 16
Diagram of Doup and Slotted Heddle Mounting for Weaved Clipped Spots

Although not indicated on the chain drafts for these clipped spot patterns, check pegs are required to suspend the operation of the take-up motion while the picks of roving are being inserted. In all the clipped spot patterns

would be a pair of mechanical fingers, which may be attached to each temple in such a way as to be manipulated by the lay of the loom. In operation, the finger moves down to catch the filling as the lay moves forward to beat up the pick. Attachments of this kind have been successfully applied to looms in one of the leading fancy goods mills in the country. They catch the filling as it is being placed in the shed, retain it until the shuttle is in the opposite box, and release it as it is being beaten up. This prevents the tension on the filling from causing the spots on the border of the fabric to be pulled and distorted.

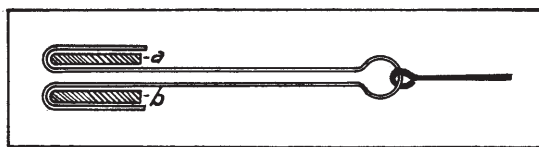

Figure 17
Diagram of Double Yoke

shown, two picks of roving were inserted at a time. This is due to the fact that a four-by-one box loom was used in this work, which necessitates bringing the shuttle back to the box side before another shuttle can be used. These fabrics were woven face down to reduce the work that would otherwise be required of the dobby. It must be remembered that if these goods were woven face up, all pattern harnesses except those used for stitching purposes would be raised on each figure pick. There is some disadvantage in this method of weaving inasmuch as the weaver can not readily observe weaving faults.

The majority of leno clipped spot fabrics finds a use in curtains and other trimmings for home decoration. The heavy yarn used in the spot forms a very pronounced pattern on the transparent leno ground. During the past season these fabrics have been woven extensively with a filling yarn contrasting in color to the ground material.

While an open ground structure is desirable for clipped spot patterns, the fabric should have sufficient closeness to avoid sleaziness. The picks per inch should be approximately half the threads per inch. This causes the

mesh to be square, since two warp threads entwine together as one and correspond to a single pick of filling. The sample illustrated at Fig. 13A was woven in a number 26 reed and contains approximately 56 threads and 28 picks per inch.

other two sets for the other side are drawn-in in a similar manner; four sets being necessary to weave the double cloth. It will be seen that the first end (c) is drawn through the legs of the top doup and through the eye of the bottom doup. The second end (f) is drawn through

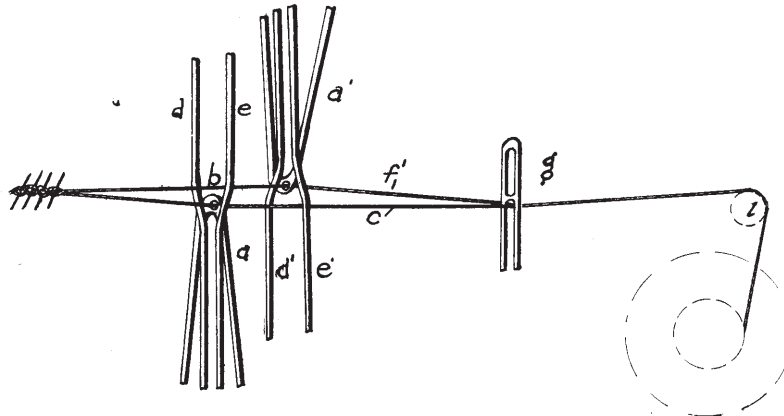

Figure 18a
Diagram of Double Doup Mounting for Weaving Leno

Tubular Fabrics. Cross-weaving provides a strong interlacing for light, open fabrics with a minimum amount of thread slippage. In view of this fact double cloth fabrics in the form of bags are frequently woven by this

the eye of the top doup and passed between the legs of the bottom doup. Fig. 18B illustrates the operation of the two sets of doups to form an open pick. The first standard of the top doup is lowered, thus passing the second end (f)

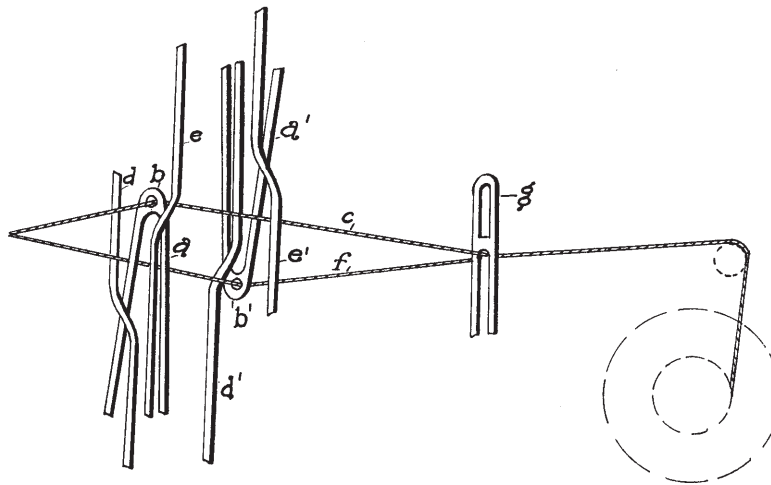

Figure 18b
Double Doup Mounting in Open Shed Position

method. A good arrangement for weaving leno tubular fabrics is with sets of bottom and top steel doups. Fig. 18A illustrates the method of drawing-in the ends through two sets of doups for one side of the tube. The

to the left side of the first end (c). The second standard of the bottom doup is raised at the same time, thus passing the first end to the right of the second end. Fig. 18C illustrates the operation of the two sets of doups to form

a cross shed. The second standard of the top doup is lowered, thus passing the second thread (f) to the right of the first thread (c). The first standard of the bottom doup is raised at the same time, thus raising the first thread to the left of the second thread.

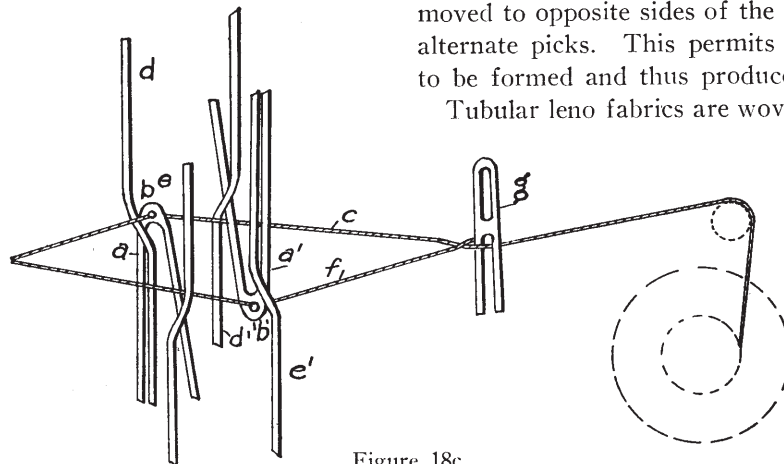

Figure 18c
Double Doup Mounting in Cross Shed Position

a very easy cross shed have been devised and find considerable use in weaving the heavier leno fabrics. These usually are made in the form of a reed with alternate wires terminating in the center, with an eye for carrying the crossing end. The ground end which occupies the same dent with the crossing end is moved to opposite sides of the crossing end on alternate picks. This permits the cross sheds to be formed and thus produce a leno fabric.

Tubular leno fabrics are woven for use prin-

This arrangement of doups may be used to weave plain leno or marquisette. The important features of this method are that no jumper or slackener mechanism is required, thus the jerky motion of the jumper harness has been eliminated. It will also be noted that the crossing of the ends runs back to the drop wires in place of occurring between a ground harness and a doup harness, as in the case where all bottom doups are used. With this method of weaving leno, the crossing is obtained smoothly, in a simple manner and with a good shed. Figs. 19A and 19B show the drawing-in and chain drafts for a tubular fabric.

Other means of cross-weaving which form

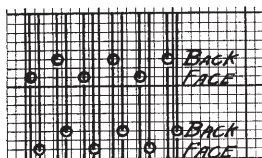

Figure 19a
Drawing-In Draft for
Tubular Fabric

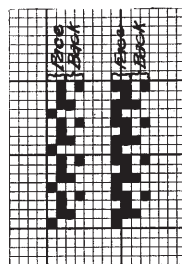

Figure 19b
Chain Draft for
Tubular Fabric

cipally in bags where a seamless open structure is desirable. These bags find a use in hosiery dyeing, laundries, and in marketing vegetables, Christmas goods, etc. In hosiery dyeing, they prevent the mixing of various sizes when it is necessary to dye more than one size in the same bath. They act as a protection to rayon materials when wet, and the dyestuff freely penetrates the open mesh of the container.

The most modern laundry firms use a heavy bag for each customer's clothes and thus prevent the mixing of clothes and eliminate the necessity of marking for identification. These bags are made on the leno principle and are woven from a ply yarn, sometimes containing as high as fifteen strands. The multiple strands of yarn produce a flexible bag which does not become stiff from continued washing.

During recent months a movement has been instituted to increase the consumption of cotton by marketing vegetables, etc., in cotton bags. Such containers are being woven on the leno principle with one side of the bag formed in mesh by the principle of leno weaving. The steel doup is adaptable to all such structures.