

LOOMS, POWER. Power-looms may be divided into four classes :

1. The plain-cloth loom, or plain loom as it is more commonly termed, in which each alternate thread of the warp is regularly raised and depressed in succession, while the weft is carried across by the shuttle at each such motion of the warp, and in which the warp-threads receive their motion from a pair of cams on the main shaft of the loom.
2. The twill looms, in which three or more cams are used, operating successively on a portion of the warp, while the weft is thrown in at the motion of each cam, in such a manner as to produce a surface marked by diagonal lines, produced by the intersection of the warp and weft.
3. The multi-harness, tappet, or chain loom, in which a number of harnesses are used, as high in

some cases as 40, which harnesses are operated by movable tappets, or adjustable projections on a wheel or chain, so as to lift them in an irregular succession, but in one which is limited by their

2944.

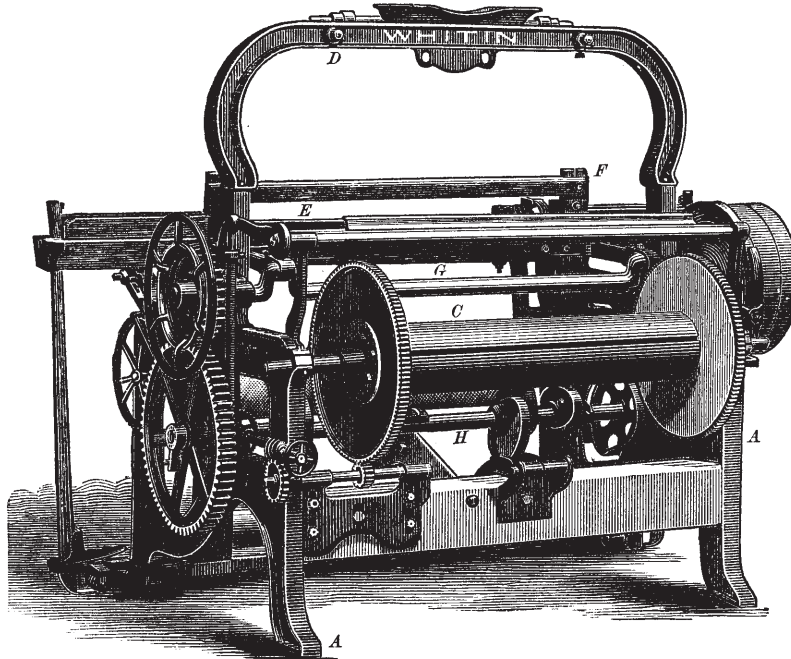

number. This loom is used for weaving fancy cassimeres, and other goods which have an irregularly figured surface, sometimes of several colors, but often only of one; and the pattern or figure is also regulated by the order in which the warp-threads are drawn through the eyes of the harness.

4. The Jacquard loom, in which each thread of the warp has an independent harness or *mail* of its own, and the operation of which is fully described under Looms, CONSTRUCTION AND USE OF.

In connection with all these looms, however, may be used the double shuttle-box, such as is applied for weaving checks and plaids, or, as in the carpet-loom, is extended to carry a number of shuttles, holding different colors.

The essential parts of all power-looms are the frame, the lathe, the shuttle motion, the harness or heddle motion, the take-up motion, the let-off motion, the weft or stop motion, the crank and cam shafts, the warp and cloth beams, the heddles, the reed, the temples, and the shuttle and shuttle-box.

Power-looms are also classified according to the manner in which their shuttles are operated, and in this respect form three distinct classes:

1. The picking-stick loom. In this loom the shuttle is made from apple-wood, jointed at both ends and shod with iron points. A slot is cut through it running nearly its whole length, in which is a spindle which carries the *cop* or weft.

2. The positive-motion loom. In this loom the shuttle is drawn through the web by the continu-

2945.

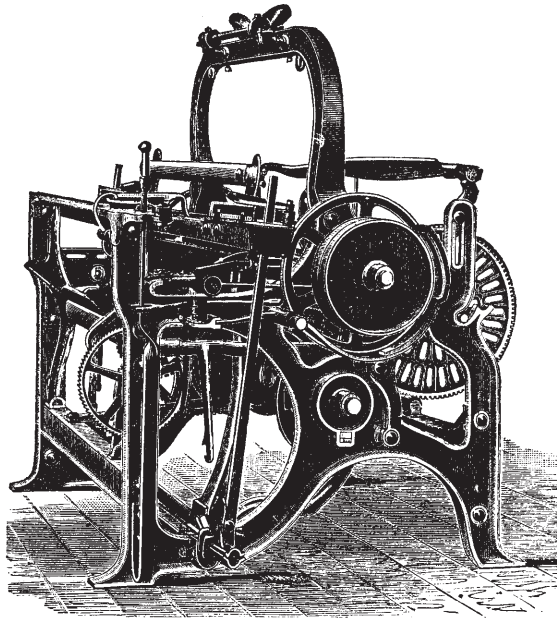

ous contact of its driver. Hence the width of the web and the number of shuttles which it is possible to carry across simultaneously are unlimited.

3. The rack-and-pinion loom. In this loom the shuttle is pushed from one side of the web and drawn out at the other, through its engagement with pinions driven by racks at each side of the web. The shuttle is made of box-wood, and is shaped like a quarter moon, with an opening of the same shape to receive the weft. In length it is three times the width of the web, and hence its use is limited to very narrow weaving. The general operation of the rack-and-pinion loom is described under "Ribbon-Weaving" in *LOOMS, CONSTRUCTION AND USE OF*.

PICKING-STICK PLAIN LOOMS.—Fig. 2944 represents a light or fast-running plain loom built by the Whitin Machine Works in Whitinsville, Mass. The loom is shown from the rear, and exhibits, besides its own especial construction, many of the essential portions common to all looms. At *A* are

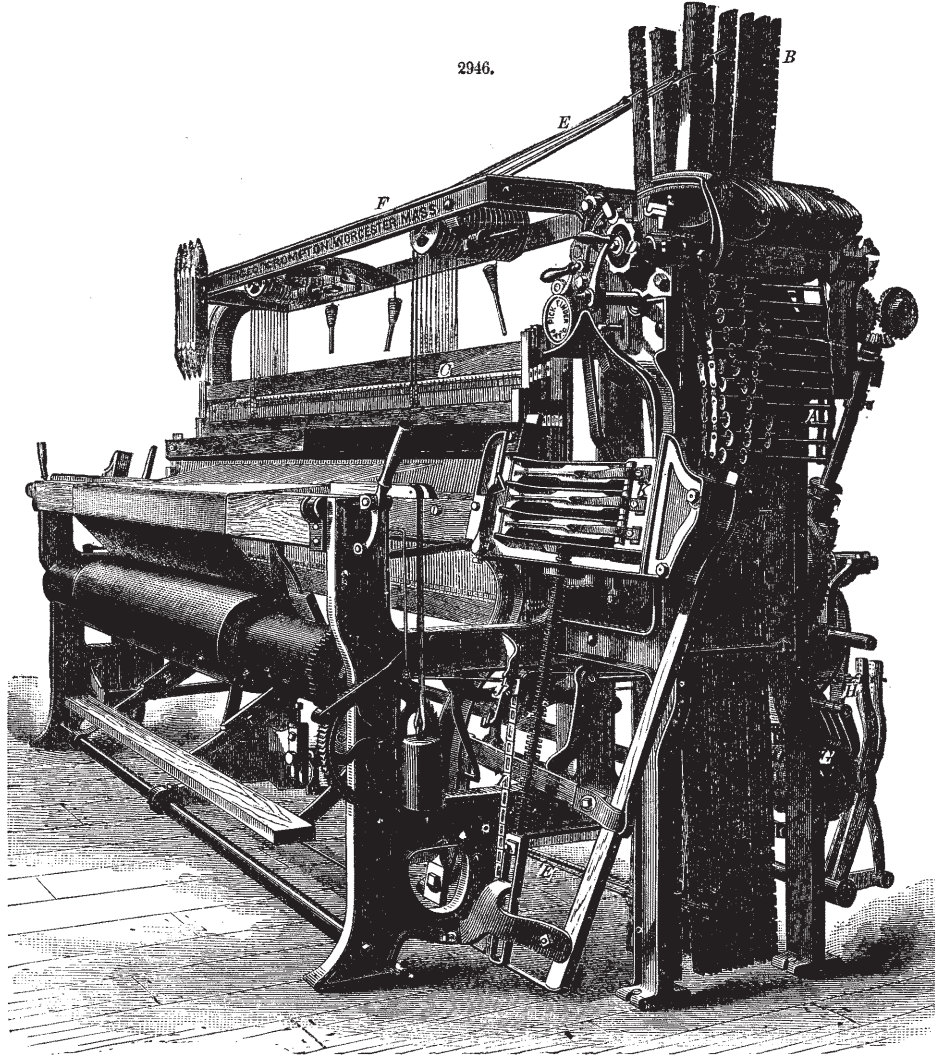

the side frames which form the gable-ends. These are tied together front and back by girts. In front is the breast-rail over which the fabric passes, and in rear is the back rail. This last is termed the back rail when stationary or the *whip-roll* when it is movable; it serves to support the web between the warp-beam *C* and the harness (not shown). *D* is the arch which extends from gable to gable, and supports the harness.

The following are the principal moving parts of this loom: The lay or lathe, *E*, supports the shuttle in its passage through the web and carries the reed. The lathe is supported by uprights *F*, called the swords, which have a fulcrum in the gable-ends near the floor. The lathe is vibrated by the crank-shaft *G*, to which it is connected by means of pitmans. Immediately under the crank-shaft is the cam-shaft *H*. The cams on this act upon treadles which move the harness. It will be

noted that these shafts are geared together. At each end of the lay are the shuttle-boxes *I*. These receive the shuttle as it is driven from side to side by the picker-staffs *K*. These staffs rock upon shoes at their lower ends, and thus the extremities are given a parallel motion. They are actuated through picker-cams secured on the cam-shaft and placed just inside the gable-ends, which act on suitable levers. These levers are connected to the picker-staffs by straps, and springs are arranged to keep each staff in the extreme end of its shuttle-box when it is not engaged by the picker-cams. Inside the shuttle-boxes "swells" are usually hinged. When the shuttle enters the box, it presses these circles outward, and thus moves a projecting rod so that the latter is prevented from acting on the belt-shipper. In case the shuttle does not enter its box, this action does not take place, and the loom is automatically stopped.

The loom represented in Fig. 2945 is designed for light goods, print-cloth, etc. The pulleys run from 150 to 175 revolutions per minute. The engraving illustrates a 30-inch plain loom built by the Mason Machine Works, of Taunton, Mass. This loom is also suited to the weaving of print-cloths.

PICKING-STICK MULTI-HARNESS LOOMS.—*The Crompton Loom*, shown in Fig. 2946, is an excellent and well-known type of the multi-harness loom, intermediate between the plain or twill loom and the Jacquard, in which a definite number of harnesses is used, within the scope of which the pattern must be repeated. This is done by the action of the pattern-chain shown at *A*. This consists of a pair of endless chains, connected by rods, on which rods are slipped movable rollers as shown, these rollers being kept in their proper places by thin collars, which are also slipped on the rods, and fill up all the space on them not occupied by the rollers. This chain passes around a carrier-roll shown at *D*, which is rotated the length of one link of the chain by a ratchet motion, connected with a crank-disk on the main shaft of the loom, at each revolution of the shaft or blow of the lathe; and passing between this carrier-roll and the harness-levers *B*, the latter, which are pivoted in the centre, are vibrated to the right and left by the chain-rollers, according to their interposition or non-interposition between the carrier-roll and the bearing points of the levers. The cords *E* pass from the top and bottom of these levers to the harnesses *C*, around the pulleys *F*, and thus raise and depress these harnesses by the lateral motion of the levers. A similar chain passing around the roller *G* operates the levers *A*, and by the chain *I* passing over the roller *J* raises or lowers the shuttle-box *K*, so as to bring the opening of either box desired level with the race of the lathe. The length or "repeat" of the pattern is of course governed by the number of links in the chain, which can be "made up" of any desired length. Twenty-four-harness frames form the limit which can well be applied to a loom of ordinary width of shed; but by applying another set of levers to the other end of the loom, with the harness threads of sufficient length to permit of the operation of their frames above and below the space occupied by the ordinary frames, and placing the harnesses in the loom alternately, so that the eyes of the long set can pass up and down between the frames of the short set, 48 harnesses can be operated.

Fig. 2947 represents a satinnet loom by the same maker as the preceding, which is designed for heavy goods, such as satins, twills, jeans, etc. It has four boxes at one end, and an endless chain governs and moves the heddle-levers, and can be readily changed to any pattern without the aid of cams. The loom is of the open-shed type, and its speed is 120 picks per minute.

Silk-Weaving Loom.—A new and very ingenious loom has been lately introduced for weaving silk fabrics. In this loom, Fig. 2948, the picker-staff *A*, which receives its motion from the crank-disk *B*, carries an eye-pointed needle, which, receiving the weft from the bobbin *C*, passes it through the open shed of the warp, where the loop of weft which is formed by it is caught and held by a selvage thread, which is passed through the loop by a shuttle motion similar to that on a sewing machine. The advantages claimed for this loom are: much higher speed, from the light weight of the needle and weft to be moved at each pick, as compared with any shuttle; less chafing and abrasion of the warp, from the very slight opening required for the shed; and the saving of loss of time in changing shuttles, the weft being fed from a long cop holding many thousand yards. The harness motion is

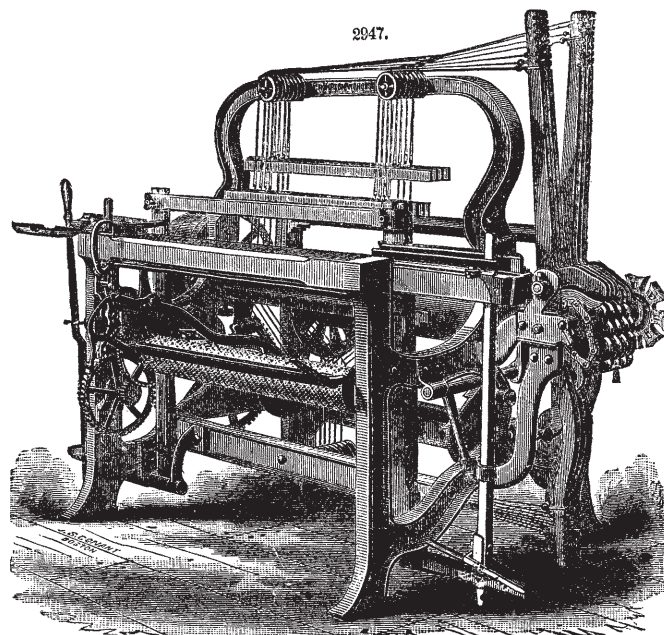

operated by cams at *D*, and is of course capable of the variations which can be given to any loom, the novelty being in the application of the weft motion.

THE LYALL POSITIVE-MOTION LOOM, manufactured by Messrs. J. & W. Lyall of New York, is a recent and very valuable invention, and is remarkable for the great scope of its usefulness. It is applica-

ble either to the weaving of very wide and heavy fabrics, such as jute canvas for the foundation of floor oil-cloths, or of the finest and most delicate yarns.

The advantages embodied are: First, the abolition of the picking-sticks; second, a positive motion to the shuttle from any point in its course; third, the unlimited width of the fabric which may be woven; fourth, the unlimited variety of fabrics which may be produced, from the finest silk to the heaviest carpet, from jute oil-cloth foundation to exquisite woven embroideries; fifth, the almost total absence of wear, through the small motion of the reed, which thus wears but little on the warps, through the small opening of the heddles, which thus offer less strain on the same, through the absence of friction of the shuttle on the yarns, and the non-subjection of the weft to sudden pull on starting; and sixth, the extremely small amount of power required to operate the looms. The shuttle motion,

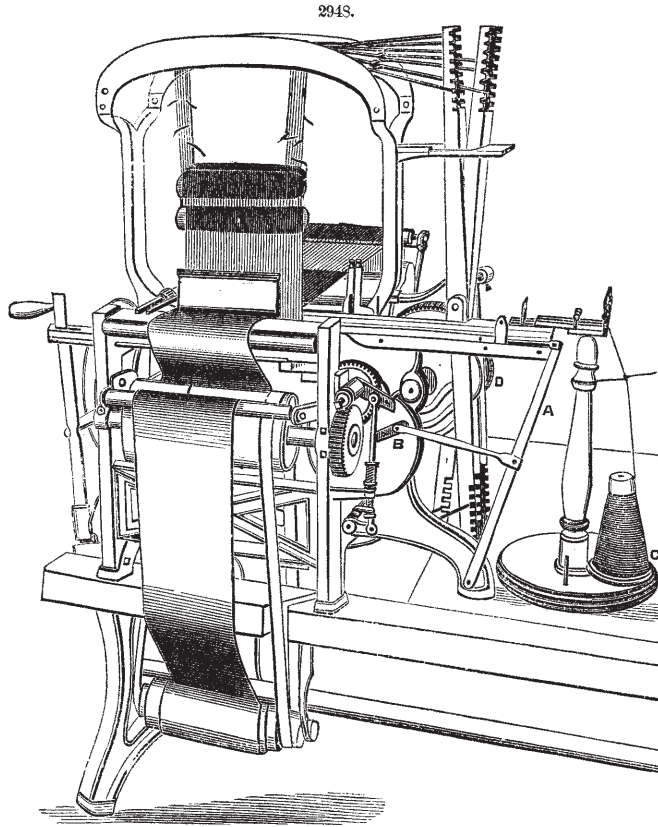

tion, which is the essential feature of the invention, will be understood by referring to Fig. 2949, where the shuttle is shown resting on its carriage *o*. Motion is given to the carriage and through it to the shuttle by means of a stout band *u*, which passes over grooved pulleys fixed to the ends of the lay and communicating with a single large pulley underneath the loom, to which, by special mechanism hereafter to be described, the proper movement is imparted. The wheels 2 of the carriage are pivoted to the ends of short horizontal arms; the wheels 3 are simply journaled in the carriage. The weight of the latter, therefore, rests on the pivots of wheels 3; and as these rest on the tops of wheels 2, it follows that they must receive a counter-motion in the direction of the arrows marked on them, exactly equal to the motion of wheels 2, which is likewise equal to the

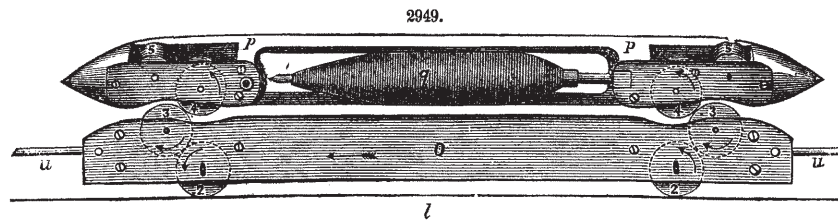

motion of the carriage along the raceway *l*. Now suppose a sheet of parallel threads to be stretched above this carriage and beneath the shuttle *p*. The only points where these threads will be in contact with carriage and shuttle are obviously between the wheels 3 of the former and wheels 4 of the latter. If we move the carriage so that the wheels 2 revolve to the left, wheels 3 will rotate to the right; and supposing the shuttle removed, it is clear that, while the threads are successively raised as wheels 3 pass under them, the rotation of said wheels precludes any lateral movement on their part. It is easy to see that the laying of the shuttle in place above the carriage will in no wise affect

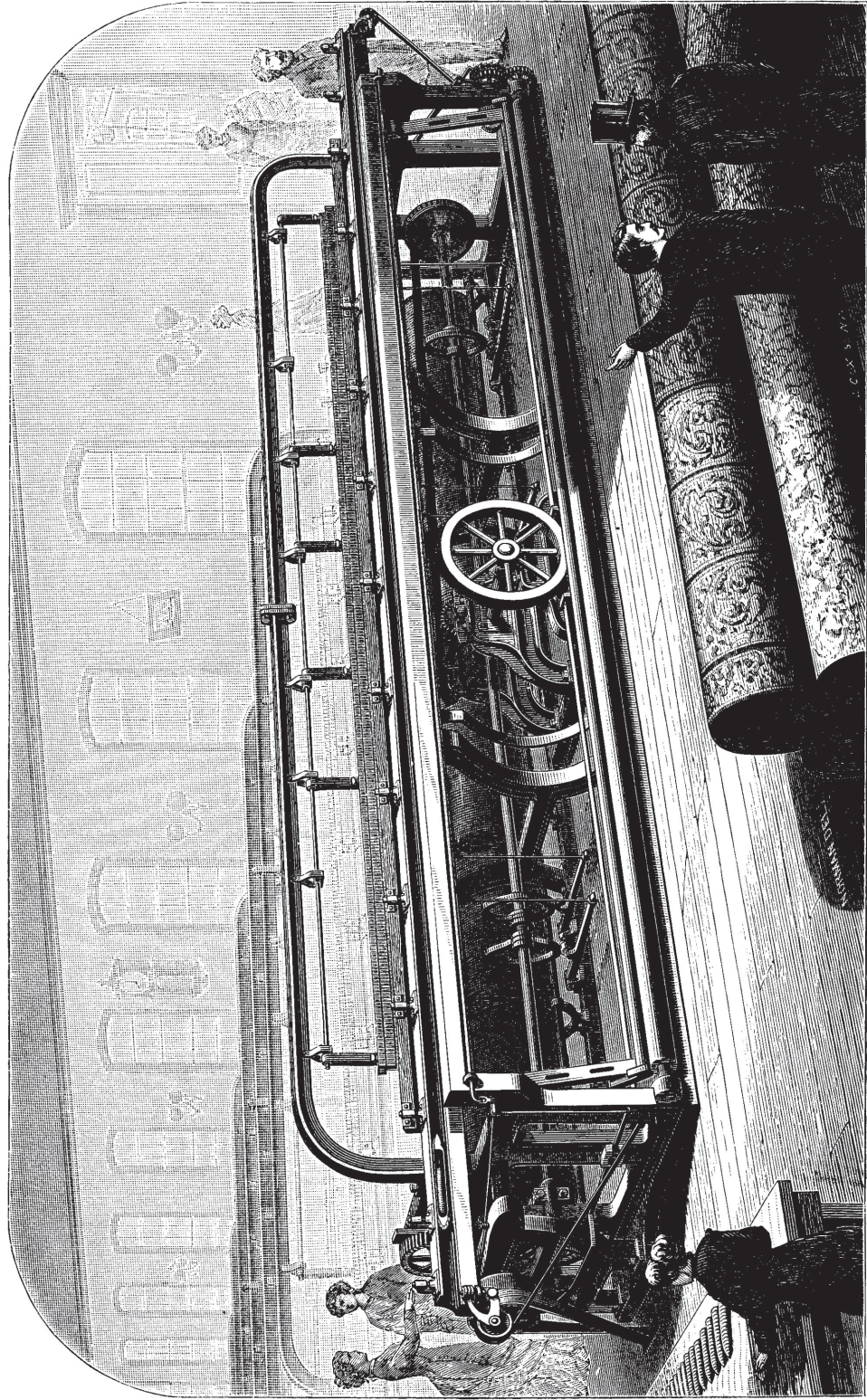

THE LYALL LOOM.

this result, because the wheels 3 rotate the wheels 4 at precisely the same speed; so that the successive threads, for the inappreciable instant of time during which they are between shuttle and carriage, sustain no disarrangement from their normal position beyond the very slight elevation, a small fraction of an inch, caused by wheels 3. This clearly imposes no strain, while a moment's consideration of the mechanics of the device will show that friction on the threads is practically

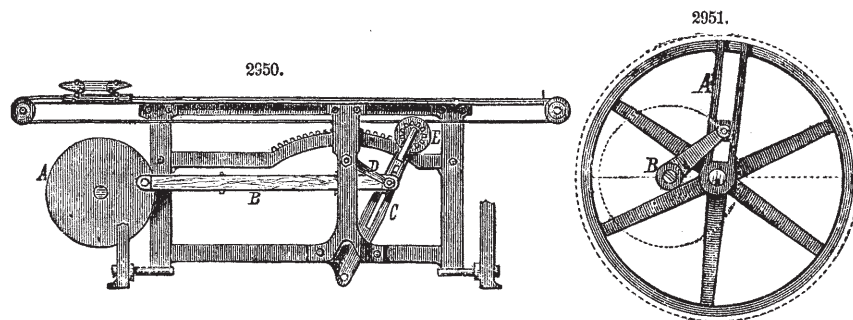

nothing, being applied at the mere line formed at the place of contact of two rolling bodies, and this never twice at the same points considered in horizontal succession from thread to thread, because the sheds are constantly alternating and constantly being moved bodily away as the weaving progresses. The wheels 5 do not engage with the wheels 4, but roll along the under surface of a beveled rail, holding the shuttle down to its work. The shuttle is dovetail in section, and, when in place with its carriage, can only be removed by drawing it out at the end of the lay.

The loom mechanism will be understood from Figs. 2950 and 2951. It is necessary in many cases to produce a dwell or period of rest, either in the shuttle or the lay. In the one case the shuttle stops sufficiently long at the end of its run to allow of the lay being beaten; in the other, the lay delays its beat sufficiently for the shuttle to make its journey. The dwell in the lay is necessary in making heavy goods. In all cases it is a great desideratum to have the motion of the shuttle swiftest midway in its course, and gentle at the ends; and one way in which this is accomplished is shown in Fig. 2950, where *A* is a crank-disk, from which motion is imparted by a connecting-rod *B* to a sliding block in the slotted vibrating arm *C*. *D* is a link attached to the sliding block and pivoted to the frame. Arm *C* carries, as shown, the wheel, actuates the shuttle-band, and is itself rotated by a rack-and-pinion device, clearly represented. When the crank-disk starts from the position exhibited (the shuttle being at the end of the race), the sliding block is at the upper end of the slot in arm *C*. Hence the arm, and consequently the shuttle, is given very slow motion. But as one end of the connecting-rod is carried up the disk, its other end causes the sliding block to descend to the arm, the wheel on the outer extremity of which, therefore, constantly receives an accelerated motion, which is most rapid when the shuttle is midway in its course, and gradually in the same manner decreases until the pick is made. The shuttle is never returned until the lay is got home; so that, no matter what the position of the shuttle is to the race when the loom is stopped, on starting again the first thing done is to draw it out of the way of the lay.

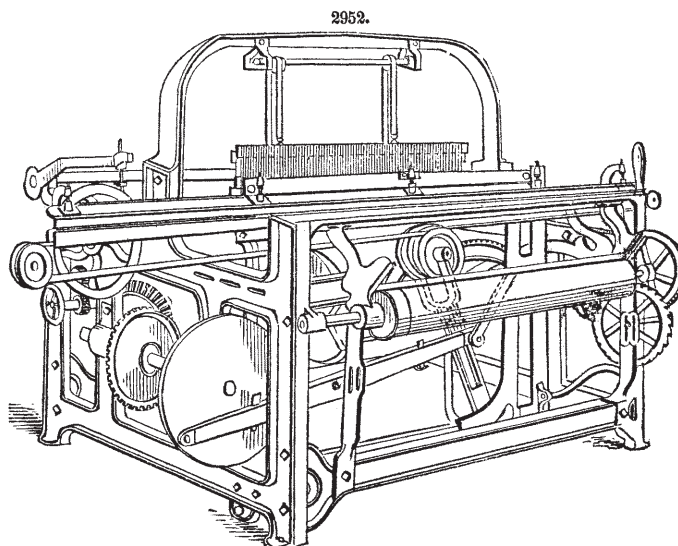

Dwell in the lay, an obvious necessity when the shuttle, in weaving wide fabrics, has to travel a very long distance, is obtained by the device represented in Fig. 2951. *A* is a slotted pulley-wheel, in the slot of which is a sliding block, to which is attached the crank of the shaft *B*, which imparts motion to the lay. The crank-wrist is eccentric to the pulley; and as the latter revolves, it moves radially in the slot. Consequently, when nearest the centre it imparts an extremely slow

or no motion to the shaft *B*, and a quick movement when it has traveled out toward the circumference.

Fig. 2952 represents the plain positive-motion loom. In a full-page engraving is shown the wide loom exhibited at the Centennial Exposition. This great machine was used for weaving floor-cloth, making a fabric 8 yards in width and 40 yards in length in 10 hours, or 320 yards per day. The shuttle traveled 31 feet at every run, and moved 35 times per minute.

Another form of positive-motion loom, Fig. 2953, weaves four webs of seamless bags, crash, canvas, etc., up to 26 inches wide, with one mechanism. There are four shuttles connected by rods in the single raceway; and they are caused to travel so that each, in passing to one side or the other, fills the place previously occupied by its neighbor. The bottom of the bag is closed in the loom, so that as the bags are woven it is merely necessary to cut them apart. The machine travels at the rate of about 120 picks per hour. An important advantage of this loom is shown by the fact that by actual test it has been found to produce more material in a given time than can four separate looms, each making one bag. The reason of this is stated to be that when four looms are used, if

2953.

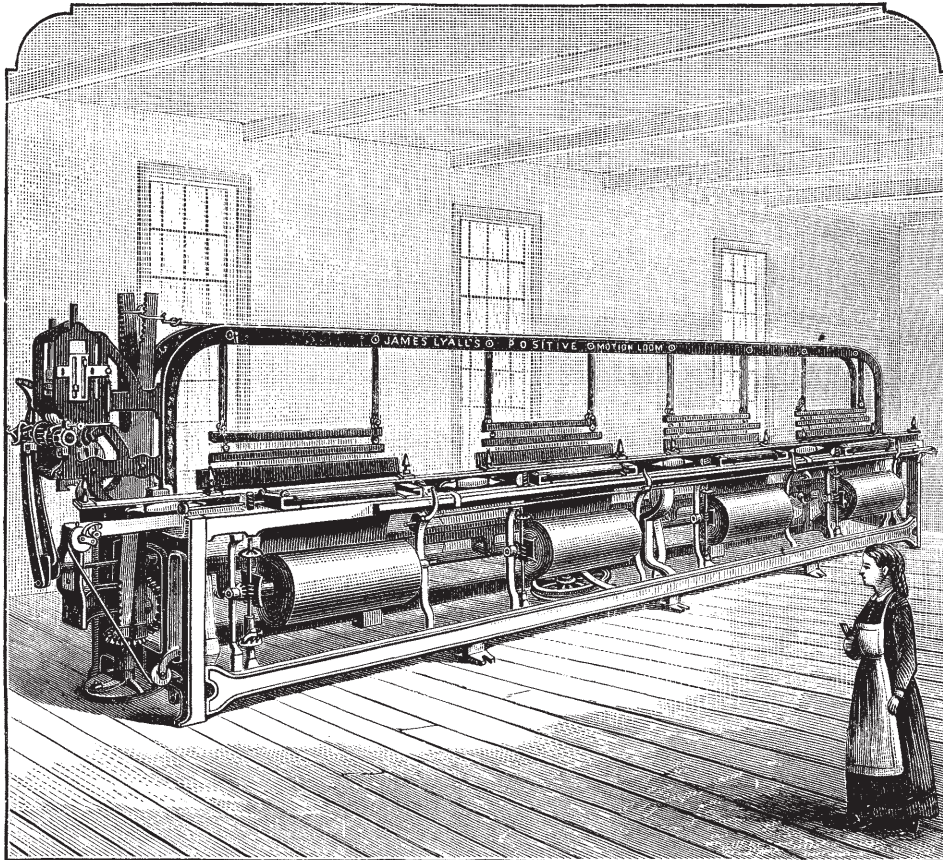

an accident happens to one of them, the entire attention of the operative in charge of the four is given to remedying it, and hence the other three looms are allowed to run on unattended, the lack of care resulting very probably in other accidents in them. The consequence is that the aggregate work of the four looms rarely exceeds the continuous work of two machines. In the four-beam loom here represented, when an accident happens, the whole machine stops, and thus no further damage can be produced. One girl can attend two of these looms, equal to eight ordinary looms.

The corset-loom, Fig. 2954, is a combination of the positive-motion power-loom with the Jacquard apparatus. Four webs of corset are woven at once, in perfect form, all precisely similar, and yet possessing every gore, every gusset, every welt formerly laboriously put in by hand-work. Five corsets per day was the extent of the labor of the German weaver; this wonderful invention makes 84 in infinitely superior manner in the same time. The Jacquard cards govern the quantity of warp to be kept in action, so that, when for instance the parts which fit about the protruding portions of the body are to be made, only a certain portion of the warp is kept in play, and through this only the weft passes. As the shuttle then does not pass through the whole warp, but over a portion of it, it would necessarily seem that a slack loop of weft, corresponding to that portion in length, would be

left. This is provided for by a let-off device in the shuttle, so that the thread, passing to and fro (after leaving the bobbin) several times between extended leaf-springs, is always held taut, and thus only the exact amount required for the pick is allowed to escape.

THE LOOM TEMPLE.—An important accessory to the loom is the "temple," which serves the purpose of holding the cloth extended to the full width of the reed during the operation of weaving. The most common form of it is represented in Fig. 2955. A pair of temples are used, one at each side of the cloth. At 6 is the roller, made of wood, and set with fine steel teeth, which revolves in the cup *c* of the temple-bar 1. This bar, with its spring 3, plays longitudinally in the stand 2, which is bolted to the breast-beam of the loom at *a*. The roll is covered by the top *e*, which just clears the point of the teeth, and the bar is held on the stand by the cap 5. The spring 3 holds the temple in position, yet permits it to yield, so as to avoid fracture should the shuttle get caught between it and the lathe of the loom.

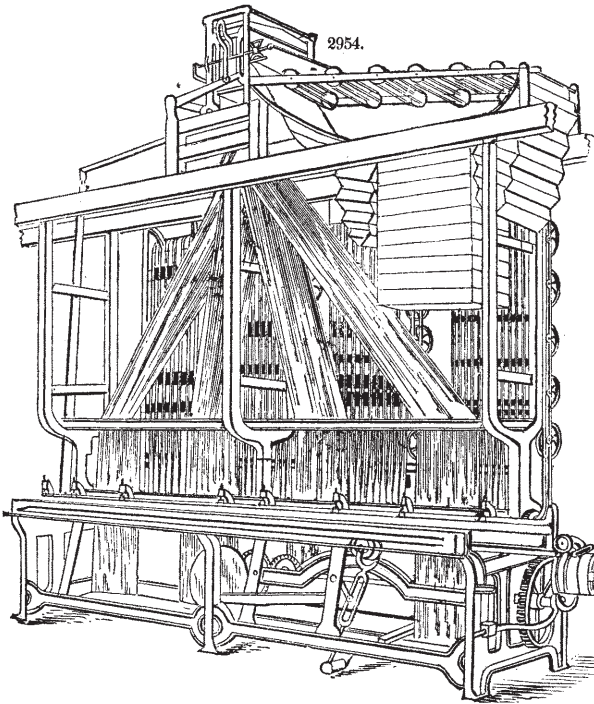

LET-OFF AND TAKE-UP MOTIONS.—The "let-off" is the device whereby the yarn is allowed to unwind from the warp-beam at such a rate as shall be required by the weaving process. This rate depends upon the rate of the picks, the sizes of the warp- and weft-threads, and the compactness with which the material is beaten up by the lay. The "take-up" is the winding on to the cloth-beam of the completed web, and this proceeds coincidentally with the let-off from the warp-beam. Regularity of let-off is secured by making

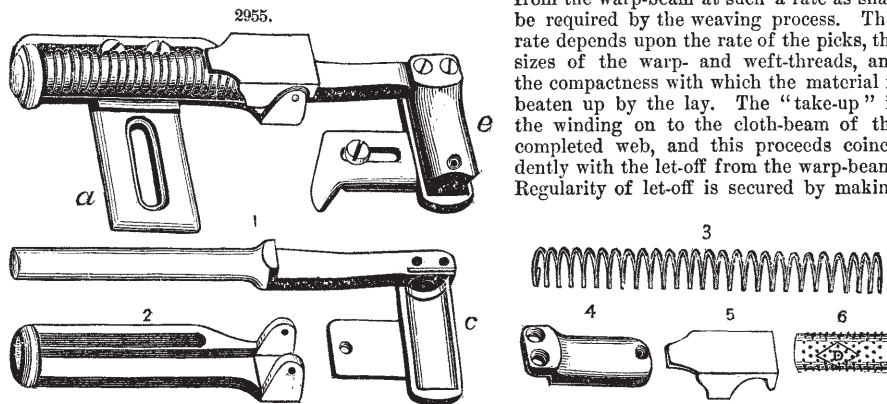

the rate of surface motion of the warp-beam depend upon the tension of the yarn; and the rate of revolution of the beam to secure equal speed of let-off will become rapid as the bulk of yarn diminishes upon the roller.

Let-offs may be either positive or frictional. In the first case they are so made as to let off a given amount of yarn and no more for each swing of the batten. A frictional let-off gives off all the yarn that the take-up will take from it. The take-up may be positive, requiring a given amount of yarn, or it may be conservative, taking all that the let-off will allow it to have. It is obvious that there cannot be both

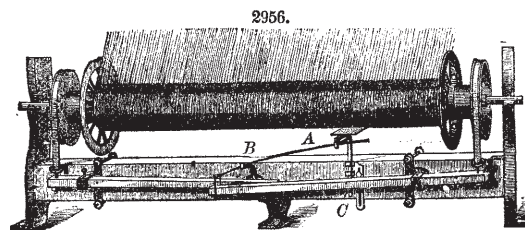

a positive let-off and a positive take-up simultaneously, because the weft-thread is never of uniform size; and not only would this have to be compensated for, but allowance would also have to be made

for the shortening of the warp due to its interlacing with the weft. The nearest approach to this is the positive take-up and frictional let-off; or there may be a positive let-off and a conservative take-up which maintains a constant pull. The relative advantages of these two systems depend somewhat on the fabric woven; but generally, for fine sheeting especially, a positive let-off is preferred, as producing a more uniform fabric.

An example of a frictional let-off is given in Fig. 2956. The platform *A* is held against the yarn by the spring *B*, which also is connected to the ends of the pivoted levers *C*. On the other extremities of these levers are brake-straps passing over wheels on the ends of the yarn-beam. As the yarn diminishes in diameter on the beam, the platform *A* rises. The strain of the spring on the levers, and consequently the pressure on the brake-straps, is thus relaxed, and the yarn is allowed to unwind more rapidly.

Positive take-ups are generally simply pawl-and-ratchet mechanism, there being two pawls, one to hold and the other to push a ratchet-wheel connecting with the cloth-beam by gearing.