

DIFFERENTIAL GEAR FOR SELF-ACTORS.

CONSTRUCTED BY MESSRS. JACOB RIETER AND CO., ENGINEERS, WINTERTHUR.

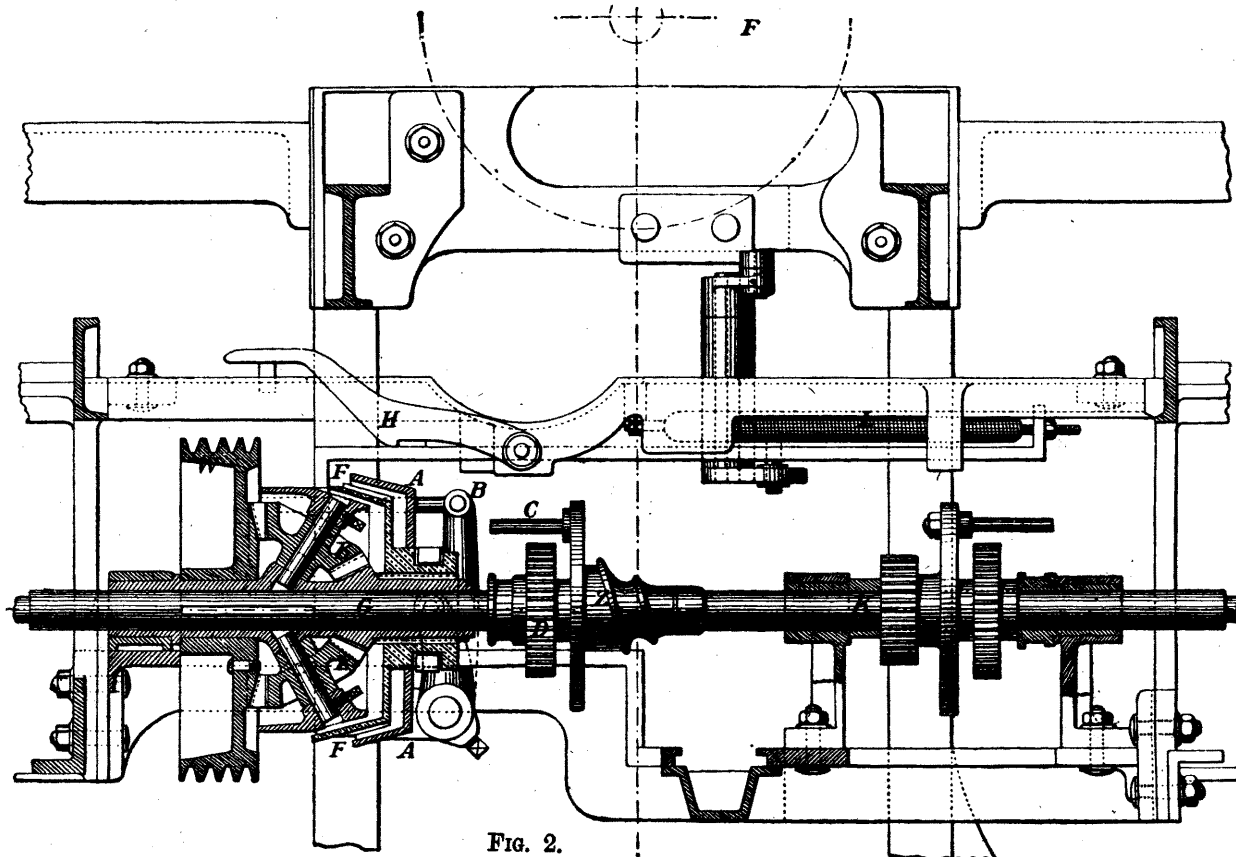
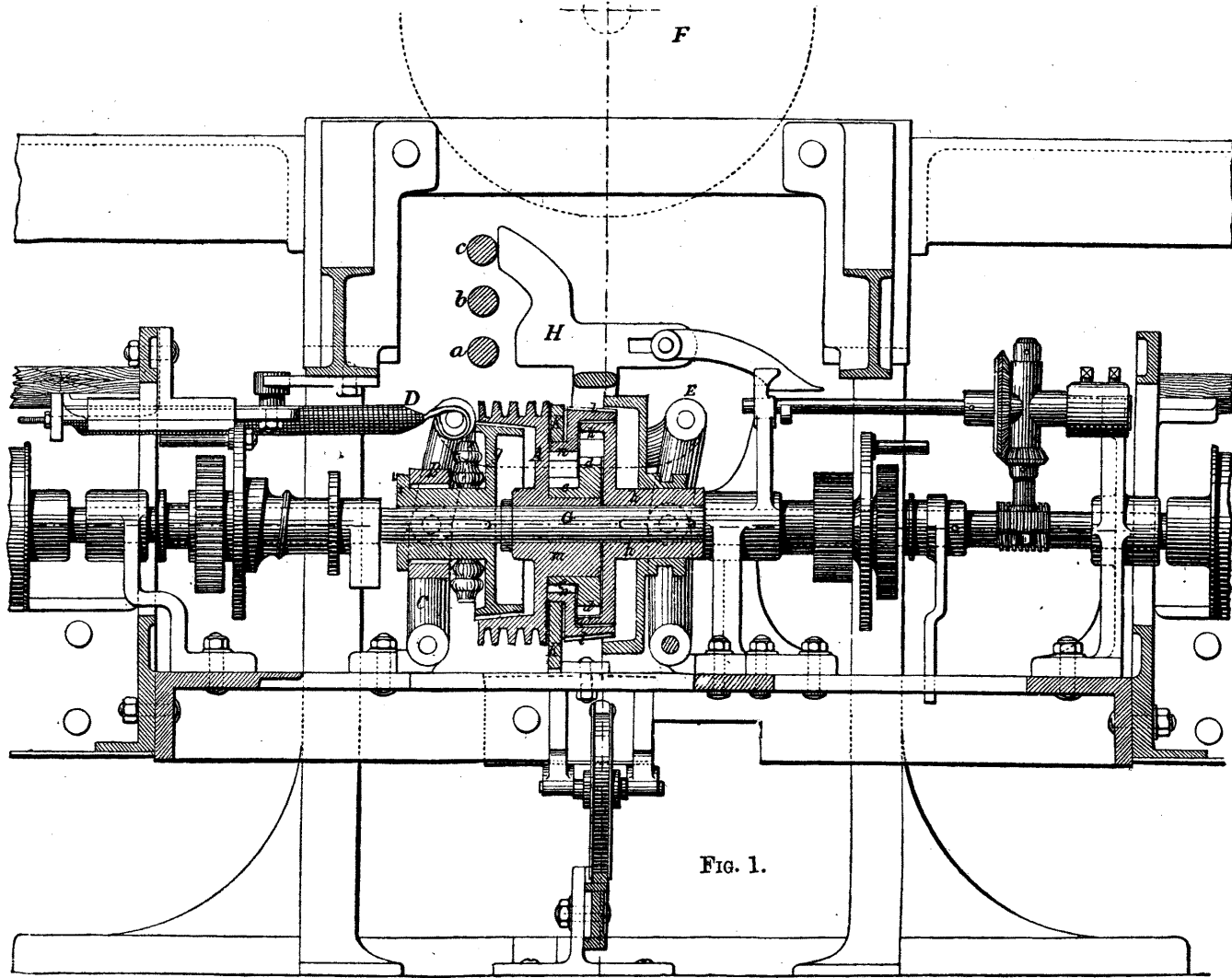

THE self-actor, partially illustrated by Fig. 1 on the present page, contains 468 spindles, pitched $1\frac{1}{8}$ in. apart. In this machine the reels are placed on the carriage, and a very simple and durable differential motion is introduced. The

arrangement of this detail is shown on the drawing. The spindle drum shaft G carries a drum A, around which are four grooves, for the twisting cord. On the eccentric box of this drum is a double-toothed wheel *e d*, which engages

with two inside geared wheels, one of which is fixed to the shaft by a key, and the other is cast within a coned drum, the periphery of which is covered with leather. The drum A is turned conical outside, and its position can be shifted

by means of the lever *c* into contact with the coned drum *g*, which is keyed to the shaft *G*, and *A* is thus connected to the latter. The coned drum, of which the toothed wheel forms a part, can be brought into contact with *F*, by means of the lever *E*, which is coupled to the lever *C*, so that both of them move in the same direction. By means of the spiral spring *D*, the lever *C* is drawn over as soon as the catch *H* is lifted out of a recess in *w*. This is done by means of the finger *P* on the counting shaft *R*, at the desired moment, and this motion being stopped by *C*, the catch *H* resumes its former position. At the forward motion of the carriage, *g* and *A* are in gear, which transfers the movement of the latter to the shaft *G*. The reverse action of the spiral spring changes the direction of the differential motion. This arrangement can be easily adjusted for winding off, according to the position of the lever *H*, and the period of position of *a b c*. The advantages of this arrangement are the saving of straps, enlarged bearings for the main shaft, absence of vibration in the carriage, &c.

The self-actor for fine yarn numbers by the same makers is shown in Fig. 2. It contains 504 spindles, $1\frac{1}{2}$ in. apart, and is built upon the Parr-Curtis system, with several modifications relating chiefly to the cylinder feeder, the winding chain, twisting and counter-winding. To avoid the undue straining of the threads, the feed and delivery cylinders have a slow motion while the stretching and twisting are effected. In warp spinning this method can be substituted for the back motion of the carriage. The feeding cylinders have also a slow rotating motion when the carriage moves forward which increases the effective length of the travel. A differential motion is employed in this self-actor to regulate the degree of twist upon the completed outward motion of the carriage. This motion is illustrated by Fig. 3.

Upon one side of the grooved cord wheel *W* is a bevel wheel *n*, into which gear the two wheels *EE'*, the latter also gearing into the bevel pinion *m*, running loose on the shaft *G*. The wheel *W* also runs loose on the boss *e*, which is of sufficient length to carry the spindles of the pinions *EE'*. On the boss of the wheel *M* is set the friction cone *F*, which can be shifted longitudinally by the lever *B*. The friction cone *A* is secured to the frame. If *F* is shifted to the left *A* acts as a brake to the differential wheel *d*, and the rotary motion of *W* is then transmitted to *G*. If *F* is shifted to the right, the pinion *m* is fixed. The number of revolutions of the differential wheel

$$d \text{ in time of one revolution of } W \text{ or } n = \frac{1}{1 + \frac{m}{E} \cdot \frac{E}{n}}$$

$$= \frac{1}{1 + \frac{m}{n}} \text{ (} n \text{ being equal to } 2m) \frac{1}{1 + \frac{m}{n}} = \frac{1}{2} \text{ revolution,}$$

which ratio holds while the carriage is moving outward, the cone *F* being in contact with *A*. In forming the twist, the catch *H* is released, and the spring *L* brings *F* into contact with *d*, when the operation previously described takes place. The spindles run at a lower speed when the carriage is travelling outward, and when this motion is completed, the maximum speed is obtained by coupling the cord wheel to the spindle drum shaft. It may be mentioned that Mr. Rieter fixes the spindle bearings in angle iron guides instead of in wood, in order to give greater rigidity.