



Slivers from the condenser at the end of the carding machine are being wound on to the condenser bobbins. There is no twist in the slivers, and the fibres would part under tension.

THE SPINNING OF WOOLLEN YARNS

*J. G. MARTINDALE, B.Sc., Ph.D., A.Inst.P., F.T.I.,
Principal, The Scottish Woollen Technical College, Galashiels*

THE preceding article has described how wool is carded, how the thin veil-like web of carded wool is split up into narrow sections, each about half-an-inch wide, which are then rubbed with a lateral movement by rubbing aprons – in the same way that the pipe smoker rubs up his charge of tobacco and for the same reason – to give the short fibres some cohesion. In the case of wool this produces continuous, soft, spongy, untwisted strands called “slivers”. The process of carding and sliver formation is the immediate precursor to the spinning operation, in which these fragile slivers are converted into strong woollen yarns.

In principle at least, the conversion is quite simple; one end of the sliver is spun round, that is, it is twisted. This twist increases the inter-fibre cohesion by binding

the fibres together and so produces a strong yarn. For a reason to be given later the strand is drawn out and made thinner during this spinning process, its length usually being increased by about 50 per cent. The binding of the fibres by twist, as well as the drafting which occurs, changes a sliver of about $\frac{1}{6}$ or $\frac{1}{8}$ inch diameter to a yarn of about $\frac{1}{25}$ inch diameter or less. These dimensions, of course, vary according to the type of yarn being spun, but are typical of the change which takes place.

Stated in this way the operation sounds fairly simple, but, in fact, it is quite complicated to carry out in practice. The spinning mule which does it is one of the most complicated machines in the textile industry – it was developed from the spinning jenny patented by

Hargreaves in 1770. In addition, the behaviour of the fibres in the strand during the conversion from sliver to yarn is not at all clearly understood and the adjustment of the mule to the needs of different wools calls for a great deal of skill on the part of the spinner, whose ability can be acquired only by his long experience of mule spinning.

THE FORMATION OF A WOOLLEN YARN

The fibres in the sliver are entangled in a random kind of way as they were arranged by the carding machine in the card web. The rubbing which they then receive rolls them together more intimately and so they hold together more effectively. This gives the sliver a unity which enables it to withstand winding on to the condenser bobbin and which will next enable it to be unwound in order to be spun. It will not stand any tension, however; if submitted to tension it will break because the softly adhering fibres will just slip apart. In consequence it must first be twisted slightly before it can be drawn finer.

The first operation of conversion into yarn is there-

fore to take about four feet of sliver and to twist it slightly. Tension is then applied and the sliver is drawn out to a longer length. This "drafting" or stretching takes place by fibres at various places along the length of the strand slipping over one another. The twist inserted at this stage must therefore not be too great or the fibres will be bound so tightly together that instead of drafting the strand will snap. On the other hand, the twist must not be too small or there will not be sufficient cohesion at some points and the strand will again break by fibres parting company altogether at these points.

All slivers are irregular in thickness along their length and it is known that when twist is inserted it concentrates in the thin places. Thus the fibres in the thin places have more cohesion than those in the thick places, and when drafting takes place it is at the thick places that the slippage occurs and consequently the thick places become thinner. This explains why drafting is resorted to in making a yarn. A fairly strong yarn could be made simply by putting enough twist in a sliver, but it would be a comparatively irregular yarn and the thick places would have a tendency to be

Woollen Mule. On the right of the machine are the condenser bobbins, from which the slivers pass between two feed rollers to the spindles in a row beneath the hands of the spinner. The spindles are mounted on a movable carriage running on rails to and from the bobbins. The curved arms bearing the yarn guides can be seen above the spindles.

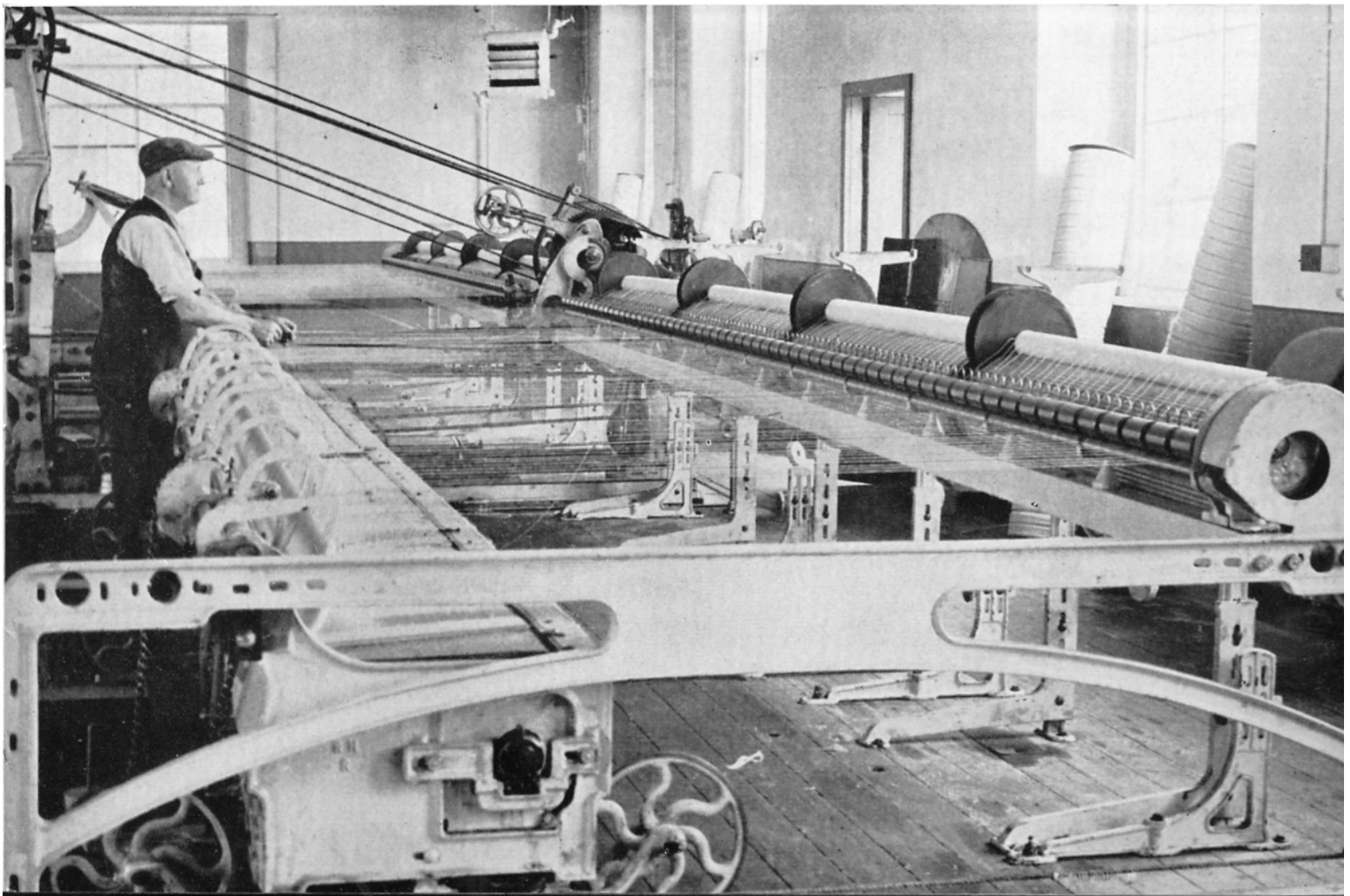

weak. As drafting works preferentially on these soft, thick places and draws them down, it produces a more uniform strand and, ultimately, a comparatively strong yarn is produced.

As drafting proceeds and these soft places become thinner, they would again slip apart if not further reinforced, so that twist must be added continually whilst drafting is going on to give sufficient fibre cohesion at all points. All the time, however, it must be graduated so as to avoid excessive fibre slippage on the one hand or excessive fibre grippage on the other, either of which would result in the breakdown of this embryo yarn.

Whilst drafting is taking place, therefore, one can picture the fibres continuously in motion. Cohesion here prevents slippage in this place; there softer places give way, slip and become thinner; extra twist is put in which reinforces these thinner places; other places then slip and so there is a continual state of flux, first one place than another responding to the draft, the result being a more uniform strand.

It will, therefore, be seen that draft is being applied against the controlling effect of twist, which produces

fibre cohesion, and although the exact conditions are not known, it appears that the best yarns are produced when the right balance is struck between fibre slippage and fibre grippage. It follows that the frictional properties of fibres and the way they may be affected by lubricants such as oil or other treatments which the wool has received before carding, must be very important.

There is, inevitably, from what has been said, a limit to the amount of drafting which can be done. If it is exceeded many yarn breakages will occur. In very favourable circumstances the sliver can sometimes be drawn out or drafted to double its original length, but an increase in length of 50 per cent is more usual; that is, the original four foot length of material becomes six feet long. At the conclusion of drafting we therefore have a six foot length of drafted, twisted sliver, but although it is much finer and more compact than the original and looks like a yarn, it is still not quite a yarn in the sense that the spinner uses the term. Up to this point fibre slippage must have been possible to permit of drafting and, if now submitted to a moderate tension, the fibres in the strand will slip somewhere and the

Close-up of the spindles. The yarn, directed by the two yarn guides, is being wound on to each spindle in a cylindrical layer to form the bottom of the cop. With succeeding layers this will become cone-shaped at the top.

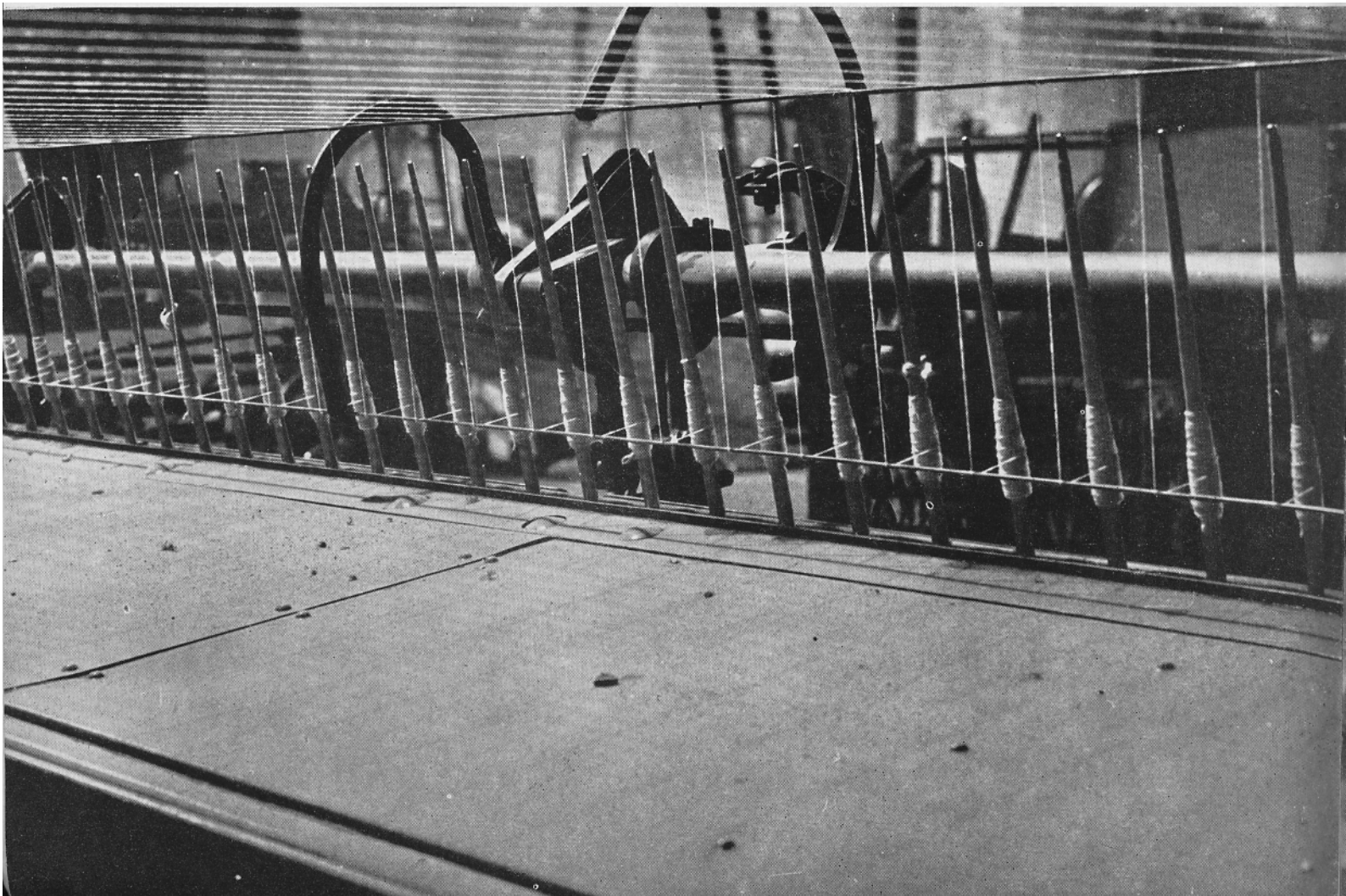

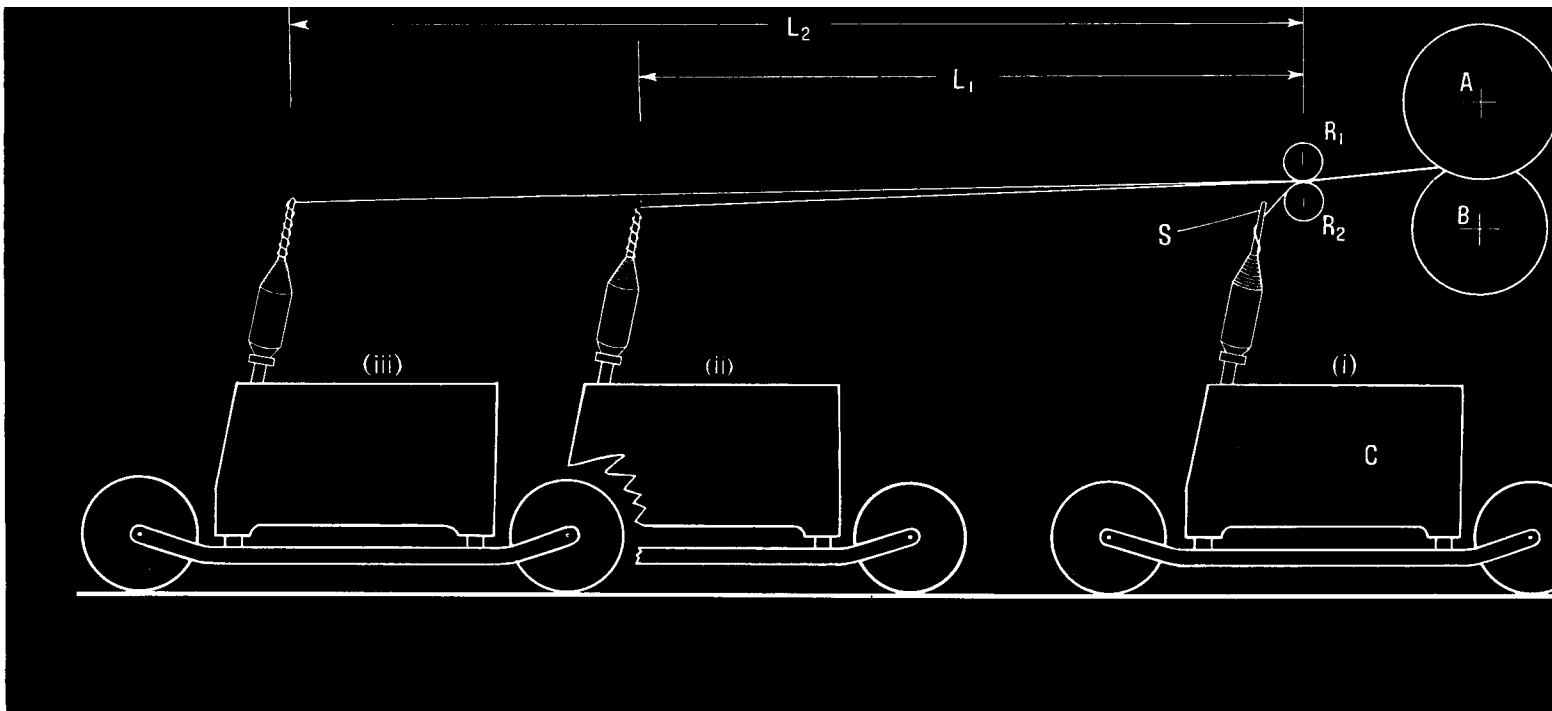

FIG. 1 Cross-section of Mule, showing the movable carriage in three positions.

strand will break. It is too soft to be a good yarn so additional twist is put in, without any further drafting, and the fibres are bound tightly together; fibre grip-page will now predominate and before the yarn will break we must actually break some fibres. The yarn is therefore quite strong and when it does break it will break with a good snap.

Yarn spinners are interested in making the best possible yarn from a given sliver and the scientific observer would think that one would have the best chance of doing this if one knew exactly what the fibres were doing and how they were being rearranged whilst this twisting and drafting was taking place, as then conditions could perhaps be arranged to produce the best results. As we have remarked, very little is known about the exact behaviour of the fibres or how they react to changing circumstances so that, although the general principles of making a yarn are simple, consideration of how to produce the best possible yarn is much more obscure. Perhaps one ought to explain what is meant by the phrase "how the fibres react to changing circumstances". It should be remembered that oil is put on wool before carding and it is still present in the sliver to be spun; different oils can be used and various amounts can be applied; fibres may be undyed or they may have been dyed and this affects their physical properties; the sliver may be drafted to different extents up to about 100 per cent. These are all various circumstances, which may have an effect on how the fibres behave during spinning and so affect the quality of the yarn made. Add to this the fact that there are many different kinds of wool, which

react to the process in different ways, and one must realise that as yet spinning is very much more an art based on experience than a science.

THE OPERATION OF THE SPINNING MULE

We now know the procedure for making a yarn and, setting aside the debatable question of how the fibres react to the process, we can at least see how it is carried out on the mule. Look at Figure 1. Here the condenser bobbin A which has been brought from the card, and on which many slivers have been wound side by side, is mounted on brackets and rests on a circular drum B. The ends of the slivers are unwrapped, are passed between a pair of feed rollers R_1 and R_2 , and each is attached to the bottom of a spindle S, these spindles being mounted in a row on a movable carriage C in position (i).

If we consider one typical strand only, what happens is this. The drum B and the feed rollers R_1 and R_2 rotate at the same surface speed so that the sliver is paid out from the bobbin and is delivered by the rollers to the spindle. At the same time the spindle carriage moves out and away from the rollers at the same speed as the material is fed to it, and the spindles begin to revolve and twist the sliver. This brings the carriage to position (ii), the slightly twisted strand is coiled round the spindle from bottom to top in spiral form and extends from the spindle tip to the "nip" of the feed rollers where it is firmly held. At this point the drum B and the feed rollers stop, and the length L_1 of the strand is ready for drafting.

The strand is now being gripped at one end by the

feed rollers and at the other end is being spun round by the spindle, to which it is attached and which continues to revolve after the feed rollers have stopped. At the same time, although the carriage C slows down, it continues to move out to position (iii) where it stops. Thus between positions (ii) and (iii) the twisted sliver is drafted to a longer length L_2 . After the carriage has reached this furthestmost position no further drafting takes place, but the spindles increase to their full speed and put in the additional number of turns of twist required to form the yarn. The full extent L_2 is usually 72 inches so that if twenty turns of twist are required per inch of yarn the number of turns in L_2 will be built up to 1,440. Now as the strand is twisted to this extent it shortens, or, if both ends are securely held, the tension in it increases considerably. This would lead to the end breaking if the tension were not relieved, so the spindle carriage moves in an inch or two to accommodate this effect as the full twist is built up. This is called "jacking in".

The length of yarn having been fully spun the spindles stop. They then make a few revolutions in the reverse direction; this is known as "backing off" and serves to unwind the few coils of yarn wrapped round the spindle. The carriage then runs back to position (i) and whilst this is happening the spindles make a few turns in the original direction of rotation and wind the yarn on to themselves *en route*. At the same time yet another mechanism comes into operation to operate a pair of yarn guides on the carriage (not shown in Fig. 1) which lead the yarn on to the spindle in such a way that a nicely shaped cop is formed.

Some idea of the complex mechanical provisions which need to be made may be gained from the following summary:

- (i) The feed rollers and drum B must run at the same surface speed, intermittently and exactly in step.
- (ii) The carriage must start on its outward journey as the feed rollers start up; it must slow down when they stop; move to the full extent; stop; move in slightly as the yarn tightens; stop for backing off; and finally return at the right time.
- (iii) The spindles revolve at a constant speed whilst the sliver is being delivered and drafted; accelerate to full speed when the carriage is right out; stop when full twist has been provided; reverse for a few turns to unwind the yarn wrapped round them and rotate slowly at the right speed and in the original direction as the carriage runs in and stop when it is fully in.
- (iv) The yarn guides must operate mechanically up and down, guiding the yarn to build up in layers on the conically-shaped nose of the cop when winding on is taking place.

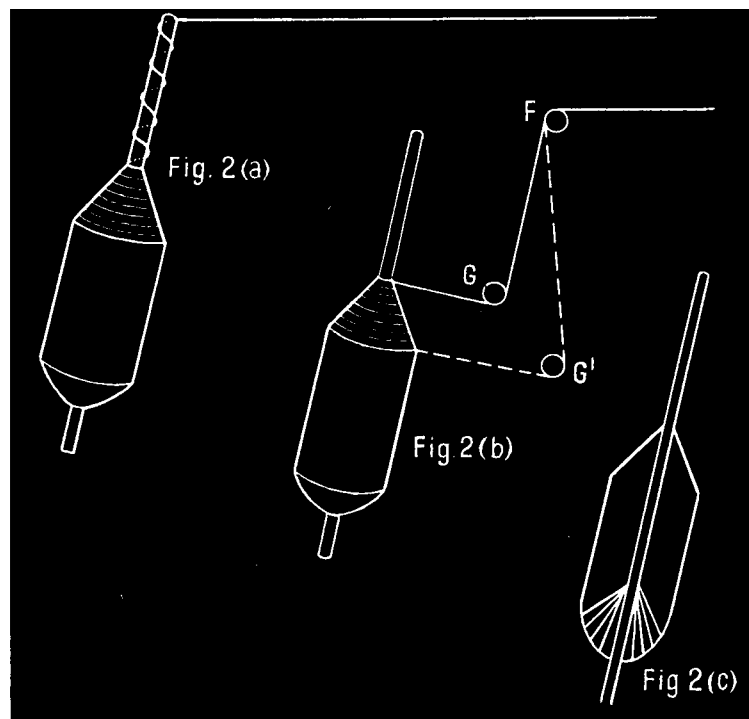

FIG. 2 Forming the cop of yarn on the spindle:

- (a) side view of spindle, with half-formed cop, before "backing off";
- (b) side view after "backing off";
- (c) cross-section showing the building-up of the cone shape of the cop.

In a short article like this it is impossible even to give a brief description of all the complicated mechanisms required to perform these many movements, and when it is realised that they must all take place in perfect harmony with each other it must be evident that the man in charge of spinning mules has to be an extremely knowledgeable and skilful person.

Perhaps one example will show the complexity of some of these operations.

Fig. 2(a) shows a spindle on which a cop of yarn has been partially built. The yarn is spiralling upwards towards the spindle tip from which it stretches to the rollers, the position being that at the end of spinning and before winding on. This six foot length of spun yarn has now to be wound on to the conical top of the partly-formed mule cop to make the next layer. As already explained the first step is to "back off", that is, remove the few coils of yarn round the spindle by rotating the spindle the requisite number of times. Note, however, that as spinning continues the cop gets larger and the length of bare spindle shorter so that fewer coils are present on it. Therefore the number of turns which the spindle has to make to back off grows continually smaller, which adds another complication to the mechanism controlling the spindle drive.

Fig. 2(b) shows the situation after this yarn has been uncoiled, but now for the first time the two yarn guides F and G have been introduced into the picture. As the carriage runs in, G first falls quickly to G¹ and so

wraps a steep spiral of yarn on the top of the cop. This spiral falls steeply from nose to shoulder and binds the previous layer tightly in position. Having done this the yarn guide at G^1 then rises slowly to its original position and builds up another spiral of yarn as the carriage runs in. It will be seen that if the carriage runs in at a constant speed – taking in yarn at a constant rate – then the spindles must revolve slowly at first when yarn is being wound on at the shoulder and must speed up gradually as coils of decreasing diameter are formed towards the nose. This would be a problem in itself, but the carriage cannot run in at a constant speed; it has to be accelerated to begin with to get it moving and has to slow down gently to a stop when coming towards the end of its inward run. Then consider that this is the situation only when the cop shape has already been established. To begin with one has to wind on to a bare spindle and start with a cylindrical layer, Fig 2(c). Succeeding layers produce flatter and flatter cones until the bottom of the cop has been made. Thus the spindle motion, which is complicated enough even when the required conical nose has been formed, is even more complicated when these ever-changing layers at the bottom of the cop are being built to give the required shape, and the mechanisms controlling the motion of the yarn guides and variation of spindle speed have to be regulated accordingly.

One cannot describe mule spinning without becoming more and more involved in complicated motions, and what is even more remarkable is that they are capable of being so delicately adjusted in relation to one another. They have to be, or else the yarn would either be so slackly wound on the one hand that the cop would fall to pieces, or so tightly wound on the other hand that the yarn would break. As one writer has said, “the more one understands the difficulties that are involved, the more wonderful does the action of the mule become”. And again, “the more one knows about a mule, the more one wonders that its inventors ever succeeded in making it work”.

There is another machine – the woollen ring-spinning frame – which can be used for making woollen yarn, but in spite of its simplicity by comparison with the mule it is doubtful whether five per cent of the woollen yarn production in Great Britain is made on this type of machine. In this country the mule is by far the more popular of the two for making woollen yarns, because it is more versatile and spinners believe that it makes the better yarn.

According to the Commonwealth Economic Committee there were over two million two hundred thousand mule spindles in operation in Great Britain in 1952 and according to the Board of Trade, 315 million lb. of woollen yarn were spun in 1953.

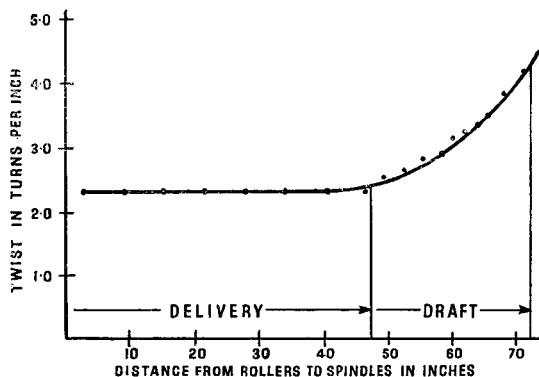

FIG. 3 During delivery the constant carriage speed and constant spindle speed maintain a constant twist of 2.3 turns per inch. During the drafting stage the spindle speed remains the same, but as the carriage slows down the twist increases to 4.2 turns per inch. Drafting then ceases.

(Courtesy: J. A. B. Mitchell)

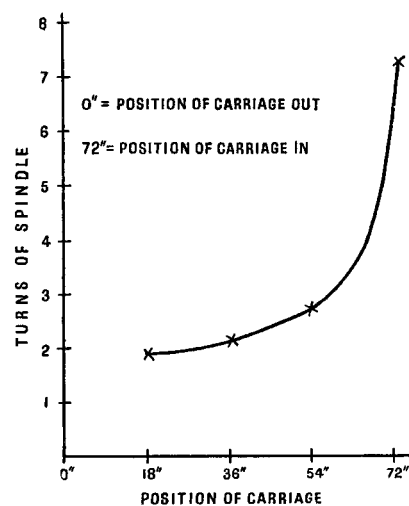

FIG. 4 Graph showing the number of turns of the spindles during four successive equal sections of the run-in of the carriage during winding on. As the carriage comes in the spindles must make increasingly more turns to wind on equal lengths of yarn.

(Courtesy: J. A. B. Mitchell)