

# RUG WEAVING TECHNIQUES

BEYOND THE BASICS

**Peter Collingwood**

*photography by David Cripps*



## RUG WEAVING TECHNIQUES



# RUG WEAVING

INTERWEAVE PRESS | Loveland, Colorado, USA

PETER COLLINGWOOD

# TECHNIQUES

BEYOND THE BASICS

*photography by David Cripps*

Interweave Press, Inc.  
306 North Washington Avenue,  
Loveland, Colorado 80537, U.S.A.

© Text & diagrams Peter Collingwood 1990

Photographs © Bellew Publishing Co. Ltd 1990

Designed by Ray Carpenter

Library of Congress Cataloging-in-Publication Data

Collingwood, Peter, 1922-

Rug weaving techniques: beyond the basics/Peter Collingwood:  
photography by David Cripps.

p. cm.

Includes index.

ISBN 0-934026-62-9: \$29.95

1. Rugs. 2. Hand weaving. I. Cripps, David. II. Title.

TT850.C59 1990

746.7'2--dc20

90-45692

Designed and produced by  
Bellew Publishing Company Ltd  
7 Southampton Place, London WC1A 2DR

Printed in The Netherlands by Royal Smeets Offset.

## Contents

<b>Introduction</b>	<b>7</b>	<b>Warp-face Weaves</b>	<b>137</b>
<b>Weft-face Rugs in Plain Weave</b>	<b>12</b>	<b>Weft Twining</b>	<b>143</b>
Warpway or Pick-and-pick Stripes	12	<b>Rug Finishes</b>	<b>148</b>
Overcast Selvage	19	Weft Protector	148
Crossed Wefts	20	Preparing the End of the Rug for Large Braids	149
Weaving Inscriptions	25	Whipping	152
Clasped Wefts	28	<b>General Workshop Notes</b>	<b>154</b>
Compensated Inlay	33	Loom and Workshop Equipment	154
Combining Skip Plain Weave with Tapestry	44	Weaving	157
Pick-and-pick Stripes in Tapestry	44	Unweaving	159
<b>Weft-face Rugs in Multishaft Weaves</b>	<b>47</b>	Conclusion	160
Double-faced 2/1 Twill	47		
Three-shaft Krokbragd	52		
2/2 Twill	52		
<b>Block Weaves</b>	<b>66</b>		
Three-shaft Block Weave	68		
Three-end Block Weave	68		
Applying Shaft-switching to Other Four-shaft Block Weaves	120		
Three-colour Block Weave	128		

# Introduction

IF THERE IS one thing of which I am completely sure it is that my designing ability is slight. I have only to hear a few bars of Bach or to glance at a Paul Klee to have it hammered home that any creativity I have is of a different, infinitely lower, order. This is not a new or depressing realization. Having missed the art school experience, I was never misled into thinking of myself or my work as in any way inspired or of great importance.

I regard myself as a weaver making workman-like textiles as well as I know how, from average quality materials, and in designs which aim at an unpretentious simplicity, which do not shout, 'Me, me . . . look at me'.

Though I missed art school, I did have two years excellent training in several production workshops in England. It was Ethel Mairet, for whom I worked for three rather stormy months, who later wrote to me with an important piece of advice, 'Make your workshop as critical as mine and you may get somewhere'. This concept of criticizing hand weaving, both my own and others', and rejecting what was unadventurous and purely traditional or used inappropriate materials or structures, made a deep impression on me. Implicit in it was the idea that a cloth simply because it bore a 'Woven by Hand' label was not automatically superior to a similar machine-woven cloth. To be justified, hand weaving had to produce what power looms could not or would not.

These ideas, linked to a quite irrational desire to live from shuttle-throwing, shaped the way I had to think and work. If I was to succeed – and those people telling me that abandoning medicine was foolish made some sort of success all the more imperative – I had to produce at a low cost and, therefore, at a fast rate. As my chosen field was rugs, this implied jettisoning all the traditional methods of rug weaving, such as knotting, tapestry, weft wrapping, because though they gave the greatest design possibilities, they were all extremely slow. This coupling of design potential with slow production has been a constant fly in my ointment, but I think shaft-switching has at last uncoupled them.

It was this desire for quick production – I aimed at three rugs per week – i.e. for the ability to make rugs by simple selvage-to-selvage shuttle-throwing, not by intricate hand manipulations of weft, that led me to explore shaft-controlled rug techniques. With such methods the weaver is taking advantage of the complexity of his or her loom; threadings, tie-ups, different treadlings and weft sequences all contribute and can be permuted endlessly. Many of the methods I used were developed from

those used in cloth weaving; so they were weft-face versions of weaves in which normally both warp and weft are visible. This proved a rich vein, especially when at last, like many other weavers before me, I invented Summer and Winter and so entered the realm of block weaves. The three-end block weave, a structure I now use almost exclusively, came later; it was quickly noted down while I tied my shoe-lace on a rug in this technique, spotted in a London furniture store.

These modest conversions and near-discoveries make me think of the Industrial Revolution. In textiles, it enabled machines to do with greater speed and precision what human hands had already been doing for millenia. The inventions brought about a change in the amount of yardage woven in a day, not a change in its type or quality. Such speed-increasing inventions continue today with water and air jet looms. But I believe strongly that there are discoveries still waiting to be made of quite another type, unconnected with picks per minute. As examples of this type, already in existence, I would include Mr Miyajima's beautifully simple loom which gives triaxial interlacing and perhaps my own shaft-switching system. Both offer the hand weaver possibilities denied him before, not in the realm of speed, but in structure and personal control over design.

This exploration of techniques took concrete form in *The Techniques of Rug Weaving* which I wrote to avoid further teaching. Since its publication nearly twenty-two years ago, I have taught continuously. That large book arguably has enough in it to keep most rug weavers busy for life, so is there any need for more information on the subject as contained in this book? But just because all those facts exist in print does not stop my mind – or the minds of other weavers – from continuing to think of new methods. Such discoveries may be thought merely academic exercises, intellectual games; though to an out-and-out structuralist such as myself, they are engrossing games. But their real importance lies in the way they point the weaver along a certain path when designing.

This is because every technique has its own specific range of design possibilities; it allows the weaver to make this type of motif, not that; it can be used with two colours, not three; it produces a rug that is the same or different on its two sides; and so on. By playing with a technique, discovering these rules, finding out what it can do easily, what it wants to do, and maybe how it can be cajoled into doing something which at first seems impossible – it is in this way that the weaver learns the special language of a technique and can use it economically and to its best advantage when designing a rug.

This approach implies that every technical or structural innovation has, implicit in it, design possibilities waiting for the weaver to unearth and utilize. But a simple equation stating more techniques equals more good rug designs is, of course, fallacious, because there is another important ingredient in designing and that is the ability to make the correct decision when two or three equally valid options present themselves.

I think one can only acquire that ability by looking, by educating one's eyes with a constant stream of good images. (How do I define correct and good? I cannot.) Written words about proportion, contrasting



textures, colour theory, types of symmetry may all be perfectly true but they will not help the weaver at that moment of decision. At that crucial moment, whether working on paper or at the loom, the weaver can only appeal to the ultimate referees, his or her eyes, and rely entirely on their judgement. I believe the appeal is more likely to bring the right answer if the referees have constantly played over things of beauty in the weaver's environment; unconsciously absorbing ideas of colour, proportion and texture, an absorption which is purely physical and wordless. The reader will find that I have not dealt with the design of each technique described but I hope the colour plates of samples, specially woven to accompany the text, will say something in this regard.

The loom on which the rug techniques and designs are to be worked is of great importance. American weavers who are surprised when they see my looms and the size of their timbers would be overwhelmed by Scandinavian rug looms. There, looms up to 13 feet (4 metres) wide are made and used. The warp sticks are thicker than the main timbers in many small floor looms, warp beams have ratchets at both ends to avoid any torsion, cloth beams are turned with elaborately geared handles – everything is on a gigantic scale. But should such a monster loom be the longed-for ideal, the twinkle in every rug weaver's eye? I think not, as its only advantages are that a large rug can be woven in one piece or that several rugs can be woven side-by-side at the same time.

Early on, lack of money and space forced me to work on a much smaller, though strong, loom, a secondhand four-poster counter-march loom by the great English maker, George Maxwell. I soon realized its weaving width of 44 inches (1.1 metres) was no great disadvantage, because if I joined accurately woven strips, I could weave a rug of any width. The widest object I have woven on it was a corduroy rug 26 feet (8 metres) wide, made in strips a comfortable 2 feet (60 cm) wide.

So I usually advise weavers to use a loom with, say, 4–5 feet (1.2–1.5 metres) weaving width. This is ideal for the usual floor rug, 3–4 feet (0.9–1.2 metres) wide; the extra width in the loom is because of the difficulty of weaving at a loom's full weaving width. This, coupled with a good method of joining strips, means the weaver can tackle a rug of any width and, moreover, do it by himself.

The problem with a loom of this size is that it may need strengthening if it is to be used exclusively and often for rugs; and here we touch on the subject of altering a loom, about which I have strong feelings.

Consider a loom used by a working weaver, perhaps in a poor country. It is a shaming and ramshackle collection of bars and sticks, with not a carpenter's joint or a decent bolt in sight. But it works. The weaver knows what is essential – even warp tension, good shedding, easy-running shuttles, a straight beat – and if it has these features, he pays no attention to the ill-assorted branches and lashings which hold it all together.

I have much sympathy with this very practical attitude and have never looked with awe on my, always secondhand, looms. If I consider that screwing a piece on here or sawing a bit off there will strengthen or improve it – or more importantly make it do something new and atypical – then I do this with no feeling of desecration. This attitude is probably

influenced by my first loom, made after a visit to a London craft shop. It was botched together from two old deck chairs and resembled two inkle looms, face to face. I then added four shafts, then pedals, then a beater with a laboriously-made reed – and it still had neither warp nor cloth beam. So, from the start, the concept of a loom as a device susceptible to alteration and improvement was deeply ingrained in me.

Quite different, and understandably so, is the attitude of a weaver buying a brand new loom. It arrives perfectly packed and with exhaustive assembly instructions, sometimes even with tools for assembly. It then stands in the living room in all its hand-rubbed glory, giving off oily smells from each perfectly finished surface. It is an object for admiration, almost veneration, so its possessor would be extremely reluctant to interfere with it in any way. This is the concept of textile equipment as art object.

But whatever concept of a loom the weaver has, he or she must realize a rug is an extreme textile and so demands an extreme loom for its making. Ideally, the loom should have great strength, good depth, excellent tension control and a heavy beater.

The strength is needed so that the high warp tension, necessary for good weft-face weaving, can be provided and maintained. How high that tension should be can be understood when one sees the hefty chains and turn-buckles fixed to the two warp bars of a horizontal ground loom used for durrie-weaving in India. That the weaver's children are allowed to bounce on such a warp, like a trampoline, shows his faith both in the warp material and its unalterable tension.

As well as general strength, the depth of the loom is very important. Imagine two pairs of warp threads, one pair twice the length of the other, and all four threads stretched at the same high tension. Now try to open a shed in each pair, i.e. pull one thread up, one down. It is obvious that this will prove easier with the longer pair; the greater length of yarn – even if it is practically inelastic like linen – having more give in it. In other words, with a highly tensioned rug warp, shedding is easier the deeper the loom happens to be.

The horizontal warp-extender I use on one of my looms gives it a depth of 12 feet (3.6 metres) at the start of a rug, though it obviously decreases during weaving. The vertical extender also effectively increases the depth of the loom.

Good control of warp tension implies the use of a large ratchet on the cloth beam with two or more pawls, or alternatively some form of gearing, like a worm drive.

When considering the beating in of the weft, again refer back to a simple horizontal ground loom. With such a loom, it is done bit by bit across the width of the rug with a heavy wood or metal hand beater, all the weaver's strength driving home just a short section of the weft at a time. It is obviously hard to duplicate that kind of compression with a single swing of the over- or under-slung batten of a frame loom. But it is surprising what effect extra weight can have. The force with which the batten strikes depends partly on the weaver's strength of arm but largely on its momentum. Its momentum is its weight times its speed; so doubling

its weight means it strikes twice as hard even though swung at the same speed. Over the years, my battens have become heavier and heavier; each addition at first seeming a burden but soon feeling normal and anything lighter feeling just plain flimsy.

For easy shedding with a taut warp, the shafts must rise and fall, rather than just rise; this means a countermarch action. The often-expressed dread of making the lam-to-pedal ties on such a loom derives from the experience of doing so on a really small loom. If a loom is of a decent size, the weaver can sit inside and tie up in relative comfort. I sit on a padded board above the pedals and do not regard this as a specially onerous task. Many loom-makers have devised tie-up systems, using chains, slotted braid, standard length cord loops, all in an attempt to featherbed the weaver in this job. But none of these systems has the *infinite* adjustability of the traditional snitch knot. Good loom cord lasts a long time; I am only gradually replacing the cords which have hung from lams for over twenty-five years.

Obviously the above advice is for an ideal rug loom and such is only necessary for a serious weaver of many rugs. A lighter, smaller, loom will produce a rug or two, but the loom may suffer in the process and the weaving will be more difficult and slow.

Many of the ideas in this book originated in classes I have given, mainly in America. Sometimes they were stimulated by a student's unexpected question, sometimes they were born out of desperation to find something new to satisfy the fastest student's needs. Sometimes, and more rewardingly, they came from the student's own application of the 'What happens if . . .' attitude I try to instil. To the latter I offer thanks and regret that I have recorded only the names of Vincent Carleton, Penny Druitt, Linda Eschels, Eisha Katar-MacGregor, Jean Young and Diana Ziegner.

As my teaching has concentrated on flat rugs made in plain weave, twill and block weaves, it is these techniques which figure most prominently in this book. Also I have not come across anything new in other fields, such as knotting, and weft wrapping. The reader will find the three-end block weave is very fully described, especially the application to it of shaft-switching, as that is the only method I now use in my own rug production.

I cannot avoid hearing references to *The Techniques of Rug Weaving* as the weaver's bible. But I hope what follows, together with the original work of many weavers worldwide, shows that a fundamentalist attitude to it is flawed; it is certainly not the last and only word on the subject of rug weaving. Though this book is really an addendum to, an update on, that bible, I have tried to make it reasonably self-sufficient.

To avoid needless repetition, occasional references are made to *The Techniques of Rug Weaving*. They appear in the form (TRW p. 34), meaning see page 34 of that book.

*Peter Collingwood, May 1990  
Old School, Nayland,  
Colchester, UK.*

# Weft-face Rugs in Plain Weave

## Warpway or Pick-and-pick Stripes

Producing cross-stripes of two colours, each consisting of some even number of picks, is perhaps the simplest weft-face rug technique and presents few, if any, problems. If, however, the two wefts are strictly alternated in the so-called pick-and-pick sequence, the result is narrow stripes or lines of the two colours running in the warp direction. Using a warp with four working ends per inch, there will be four of these lines per inch, each lying over a warp thread. This commonly-used technique leads inevitably to problems at both selvages where the outermost warp thread is missed by both wefts. Disregarding methods in which the two wefts are either linked outside the selvage (making it untidy), or float over or under two ends (making it loose), there are at least three distinct ways, described below, of solving this very basic problem. (It is assumed that there is an odd number of working ends in the warp.)

### Grierson Method

(TRW p. 104 onwards. First described by Ronald Grierson in *Woven Rugs*, Dryad Press, 1952)

When moving from a solid colour to these stripes, there are always two options. Either the previously-used colour or the new colour becomes the edge stripe; see *Fig. 1(a)* and *(b)*, respectively.

A different method of work is needed for each of these possibilities. See Plate 1 at top.

#### (a) So that the previously-used colour, A, becomes the edge stripe

Stop weaving A when it is passing *over* the selvage end. This could be at the right or left side, depending on the direction A was thrown in the first shed. Here it is at the right; see *Fig. 2(a)*.

Start B, the new colour, at the same side and throw to the left; see *Fig. 2(a)*.

Now wrap A downwards between ends 1 and 2, tying down the

starting float of B, and then throw it in the next shed; see *Fig. 2(b)*. This is the only place where B reaches the selvage.

The weaving then proceeds normally for this method, with B always missing the selvage and A always wrapping twice downwards to compensate for this before being thrown; see *Fig. 2(c)*.

#### (b) So that the new colour, B, becomes the edge stripe

Stop weaving A when it is passing *under* the selvage end. Start B at the opposite side; see *Fig. 2(d)*. The two colours are now emerging at the left selvage exactly as in *Fig. 2(b)*, but with the colours reversed.

Weave normally; A is now the colour missing the selvage and B has to wrap twice downwards before being thrown.

#### Notes

- *The result of this method is a perfect upper surface, but with the forward 'jumps', where A or B misses the selvage, clearly visible as spots on the back. See Plate 1 (pp. 14–15), top section, back view.*
- *If the weft is wrapped upwards, instead of downwards, it forms a float under two ends at the selvage.*
- *Disobeying the above rules results in the rug being woven upside-down, with a perfect underside.*

### Counter-changing colours

To counter-change the colours, so that the stripes shift sideways over one warp end, as in *Fig. 3(a)*, two picks of one of the wefts must be woven in succession. It does not matter which weft is used, but if the one forming the outermost stripe is chosen there are no problems at the selvage; see the two picks of dark weft, A, at lower arrow in *Fig. 3(b)*, and the change of the colours above.

If the colour *not* forming the outer stripe weaves the two picks (see the two picks of B, now *not* forming the outer stripe, at upper arrow in diagram), then the selvage has to be handled as shown at the right. One weft, B, passes over two ends making a float, which is immediately bound down by weft A diving down between ends 1 and 2 before it is thrown. Plate 1 (pp 14–15), top section, shows this counter-changing.

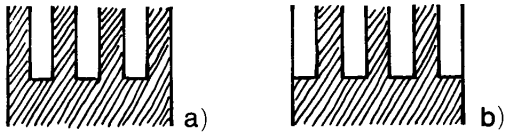

Fig.1

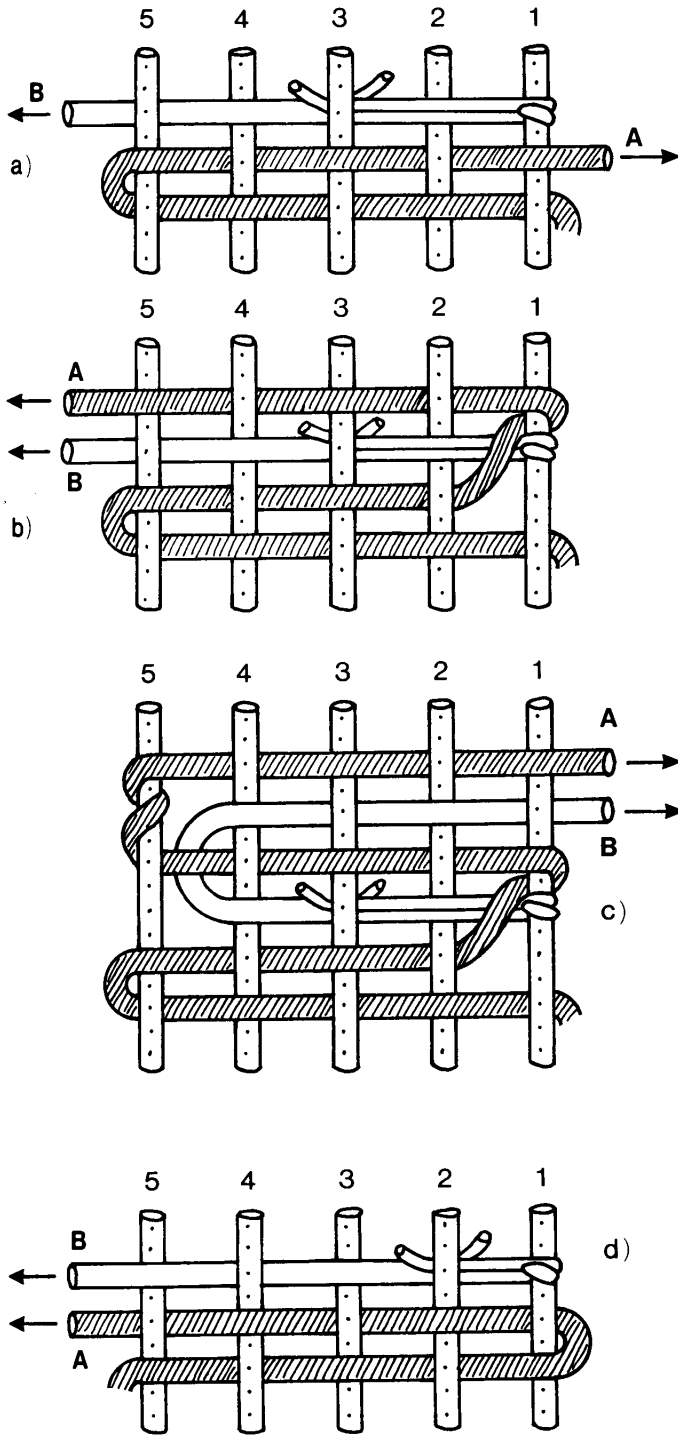

Fig.2

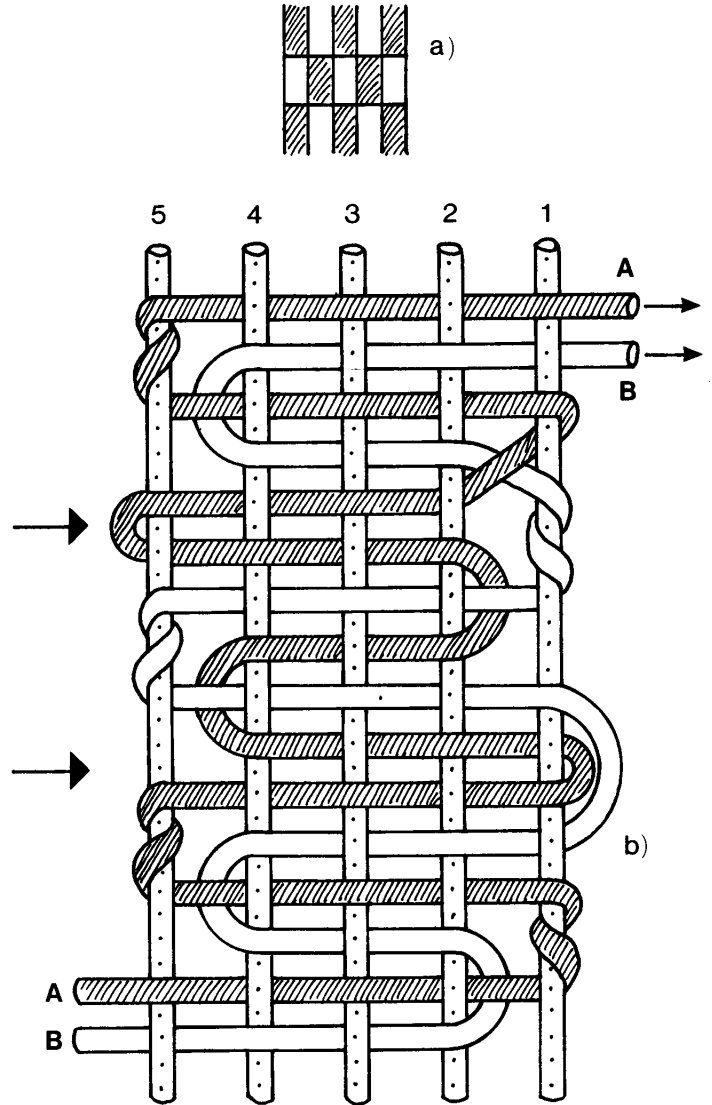

Fig.3



FRONT

Plate 1 (see pp. 12, 16-18)



BACK

## Navaho Method 1

Though the two wefts are linked in this method, the link is pulled inwards, avoiding any lumpiness at the selvage.

### (a) So that the previously-used colour, A, becomes the edge stripe

Stop weaving A when it is passing over the selvage end.

Start new colour, B, at the opposite side and place it over A; see Fig. 4(a).

Throw A in the next shed, leaving a loop at selvage; see small arrow in Fig. 4(b).

Throw B, pulling this loop around to the back, as in Fig. 4(c). This pick misses the selvage.

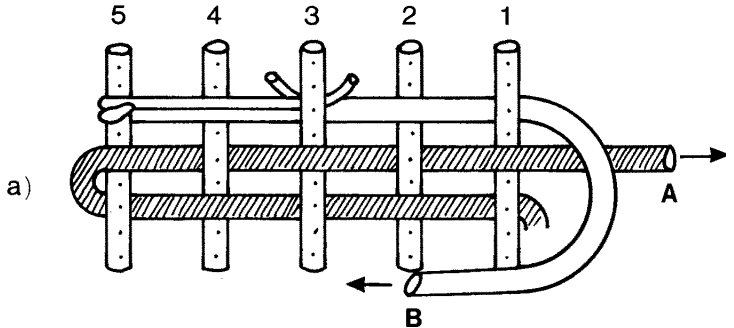

Fig.4

### (b) So that the new colour, B, becomes the edge stripe

See Plate 1 (pp. 14–15), central section.

Stop weaving A when it is passing under the selvage end; at left in Fig. 5(a).

Start B at the opposite side and pass it under A as it emerges from the shed; see Fig. 5(a).

Throw A, ensuring it crosses over B, and tighten it so that a loop of B is pulled to the back, as in Fig. 5(b). A misses the selvage.

Throw B normally; see Fig. 5(c).

#### Notes

- The result is a perfect upper surface, but on the back the two outer ends are covered with the same colour.
- This is a very simple method as no wrapping or unusual working is required at the selvages.
- To counter-change the colours, weave two consecutive picks of B, either one more in Fig. 4(c) or in Fig. 5(c).

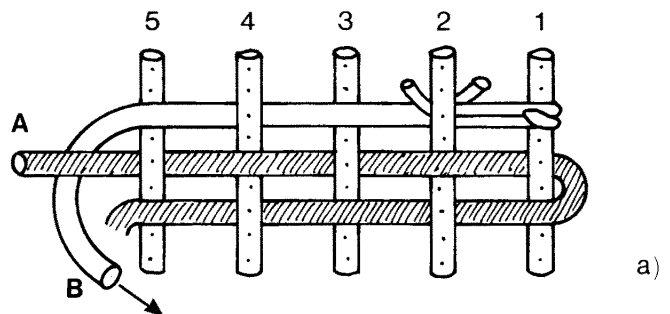
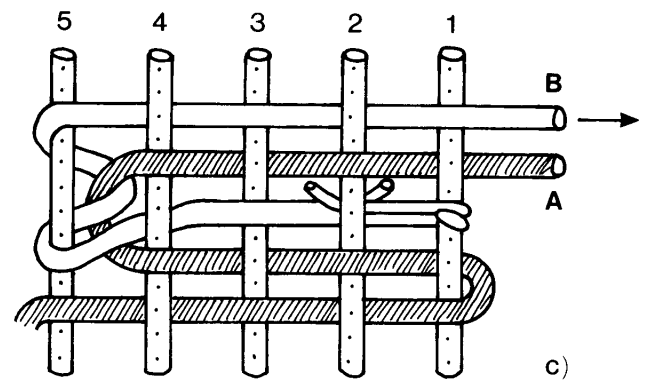
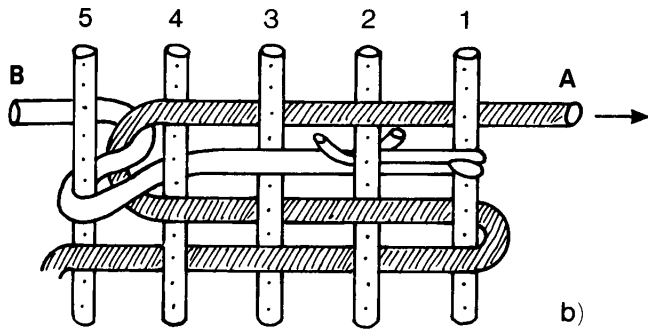
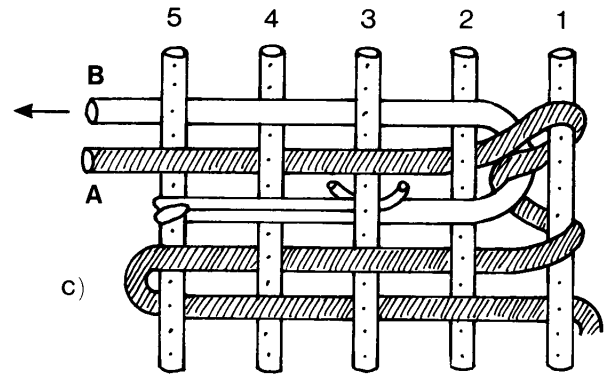
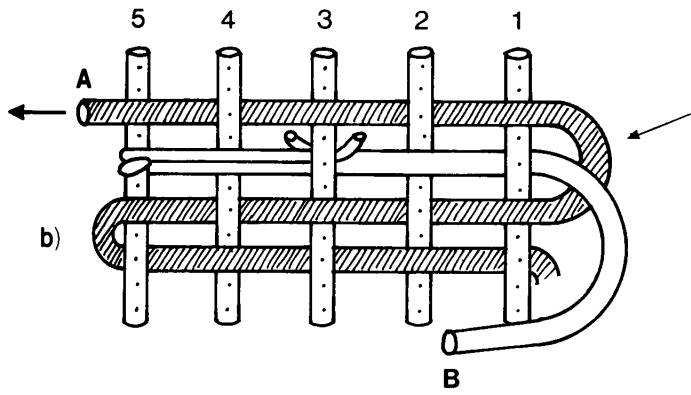

Fig.5





## Navaho Method 2

(Seen on blanket from Coal Mine Mesa,  
Tuba City, Arizona.)

There is no one-colour stripe over the selvage end with this method. So it is the stripe *next* to the selvage which is referred to in the headings below.

### (a) So that the new colour, B, becomes the stripe next to the selvage (as in Fig. 6(a))

Stop weaving A when it is passing over the selvage end.

Start B from the opposite side, making it lie under A when it emerges from the shed; see Fig. 7(a).

Enter A into the next shed, but pass it under the selvage end, 1 (which is lowered), so it is floating under two ends, 1 and 2; see Fig. 7(b).

Bring B *upwards* between these two ends, thus tying down the above float, and then throw it in the next shed; see Fig. 7(c). B should be pulled tight enough to make this crossing point lie in the centre of the thickness of the rug. See Plate 1 (pp. 14–15), bottom section.

### (b) So that the previously-used colour, A, becomes the stripe next to the selvage (as in Fig. 6(b))

Stop weaving A when it is passing under the selvage end.

Start B at the opposite side and bring it over A as it emerges from the shed; see Fig. 8(a).

Enter A into the next shed, but pass it over the raised selvage end 5, so it is floating over two ends, 4 and 5; see Fig. 8(b).

Take B *downwards* between these two ends, thus tying down the above float, and then throw it in the next shed; see Fig. 8(c).

#### Notes

- The result of this method is that both colours wrap alternately around the selvage, giving a pleasant fine striping.
- There is no back or front in this completely reversible and excellent method.
- It is really a very clever, but extreme, use of Crossed Wefts in Contrary Motion, the outer areas of cross-stripes being reduced to the absolute minimum.
- The simplest way to counter-change colours is to weave two picks of the weft which arrives second at either selvage; i.e. in Fig. 7(c) weave another pick of B to the right, or in Fig. 8(c) weave another pick of B to the left. Plate 1 (pp. 14–15) bottom section, shows these two counter-changes.

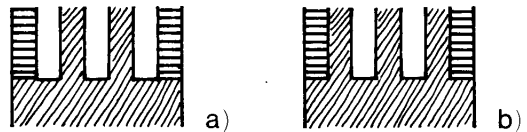

Fig.6

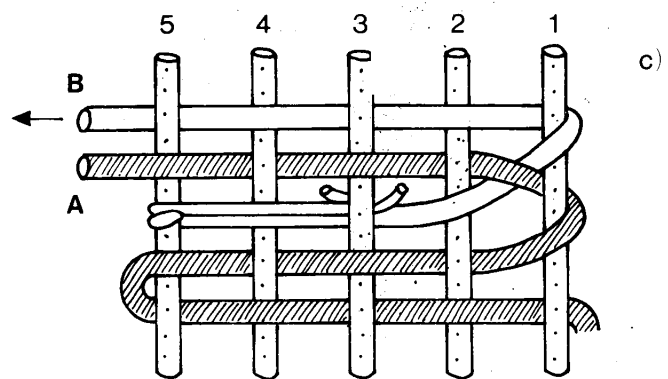
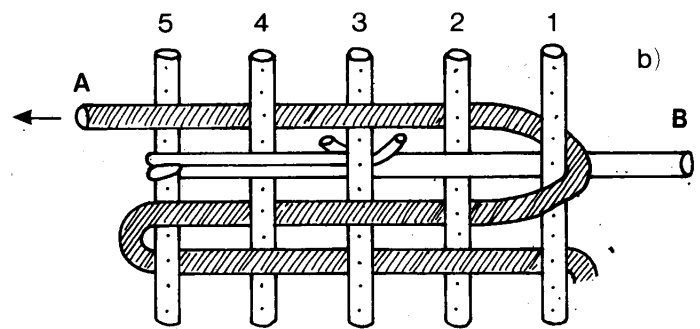
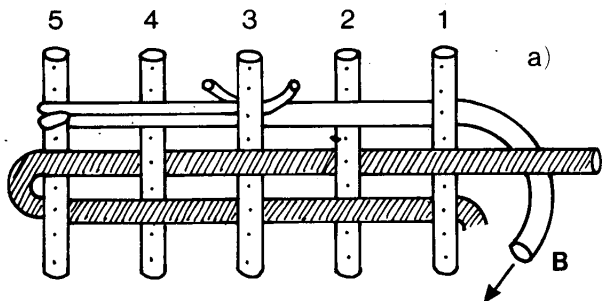

Fig.7

## Overcast Selvage

This ingenious way of producing an overcast edge is really a special application of the Gauze Soumak technique (TRW p. 190), confining it to the two outer working ends on both sides of a weft-face rug.

Throw the weft from left to right normally, as at bottom of *Fig. 9*.

Change the shed.

Twist the outer selvage end, 1, over the next end, 2.

Insert the shuttle through the opening thus formed and then into the shed. Make it leave the shed through a similar twist in the last two ends, 7 over 6; see *Fig. 9*.

Beating causes the warp ends to untwist and the weft then lies as in *Fig. 10*, which includes the next pick.

As seen in Rajasthan, the outer two working ends are three to four times thicker than the rest of the warp. The loom is a horizontal ground loom, the sheds being produced with a shed rod and leashes. The thickened outer two ends go over and under the shed rod in the usual way, but the outermost one is not attached to a leash (see top of *Fig. 9*) as it would normally be. The initial shed, as described above, is given by the shed rod and goes right across as required; the second shed, with the rod pushed away and the leashes raised, leaves the two outer ends level with each other and therefore easy to manipulate in this way.

A rising shed loom with a floating selvage at each side will give almost the same conditions.

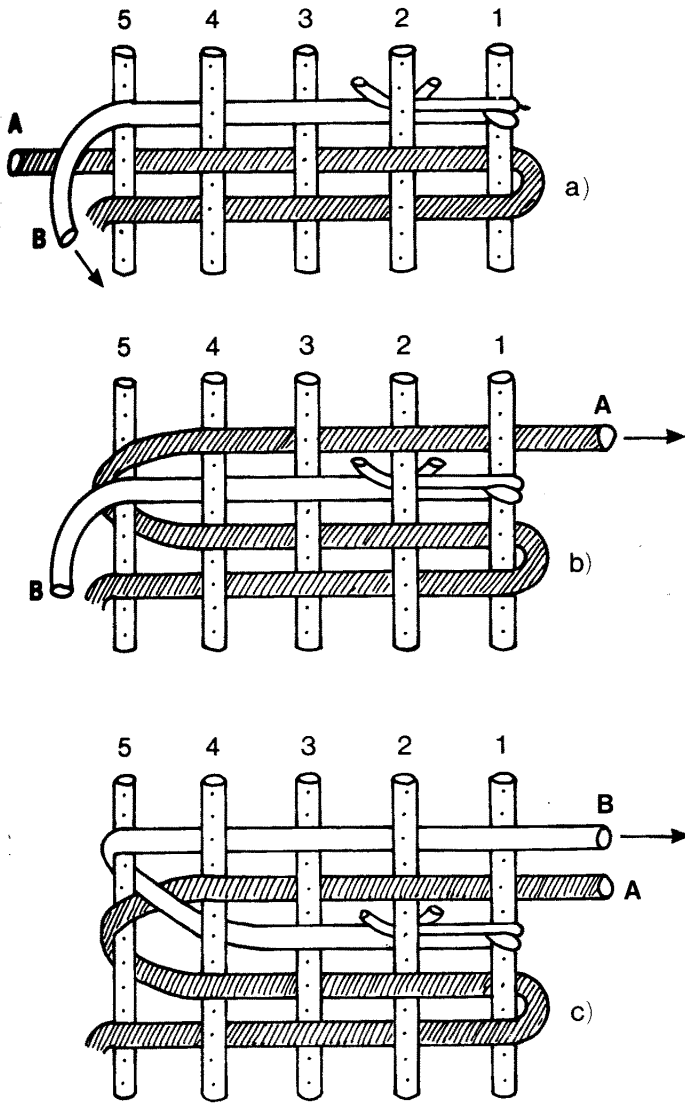

Fig.8

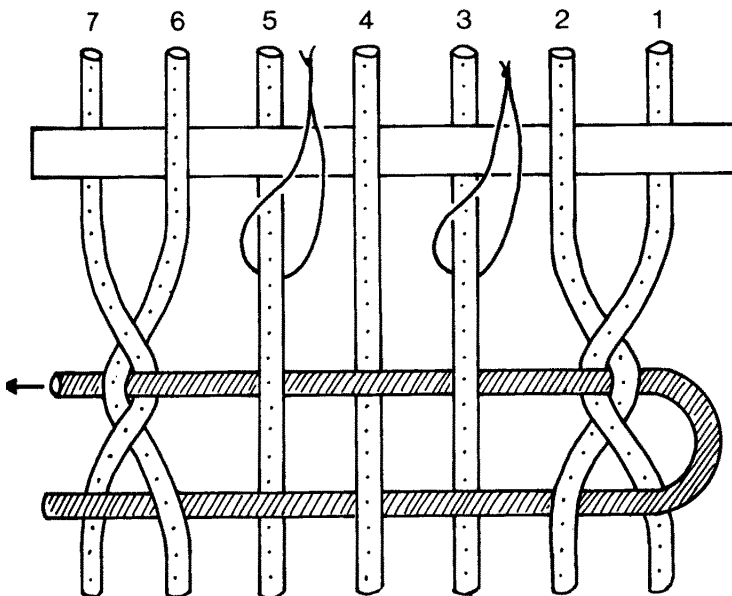

Fig.9

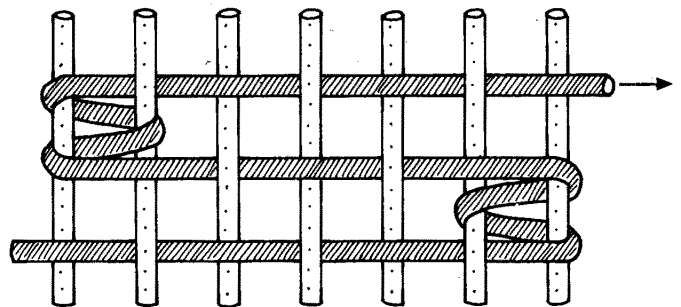

Fig.10

## Crossed Wefts

In the Crossed Weft technique, two wefts starting either from opposite selvages in the same shed (i.e. in Contrary Motion; see Fig. 11, bottom) or from the same selvage in successive sheds (i.e. in Parallel Motion; see Fig. 11, top) actually cross each other one or more times as shown. In both types of motion, the crossing has a very characteristic structure. The first weft to move at a crossing inevitably floats over two ends, but this is tied down by the other weft which floats under the same two ends. So in Fig. 11, bottom, the dark weft passes over ends 5 and 6 and is tied down by the light weft passing under the same two ends. Failure to work this correctly produces a weakness at the crossing point.

This simple crossing manoeuvre which reverses the relative position of the two wefts usually produces horizontal and vertical stripes in areas, the shapes of which are freely controllable; see Plate 2 (p. 22). Some further possibilities are now described.

### Areas of Spots

These can be produced in at least two ways.

#### (a) Parallel motion

As Fig. 12 shows, one method is worked with Crossed Wefts in Parallel Motion, the two wefts having one crossing pick followed by four straight picks. The alternating areas show

interrupted pick-and-pick stripes. There is not a great deal of contrast between the two areas; see Plate 3 (p. 22).

#### (b) Contrary motion

The second method, worked in Contrary Motion, has a third weft the same colour as the background of the spotted area; see Fig. 13. The unspotted areas have stripes of unequal width. It is interesting that when the areas are counter-changed, only two wefts are needed, as shown in Fig. 14. Plate 4 (p. 23) shows this technique.

### Increasing the Width of Cross-stripes

Cross-stripes of two picks are usually narrower than the vertical pick-and-pick stripes, and can cause a design using both types of stripes to look unbalanced. Fig. 15 shows a way of increasing their width to three picks. It needs four wefts, two of each colour; two of these always move in Parallel Motion, crossing twice, the other two weave single picks straight across in sequence.

If woven as in the diagram, the 3/3 cross-stripes will be in the central area with pick-and-pick stripes on either side.

#### Note

— It is the straight, non-crossing picks that determine which areas show which type of striping. So by simply reversing their sequence, (i.e. by starting with a solid line weft, not a dotted one, for the third pick up in Fig. 15), the areas can be easily counter-changed; see Plate 5 (p. 23), which also shows the difficulty of producing neat selvages.

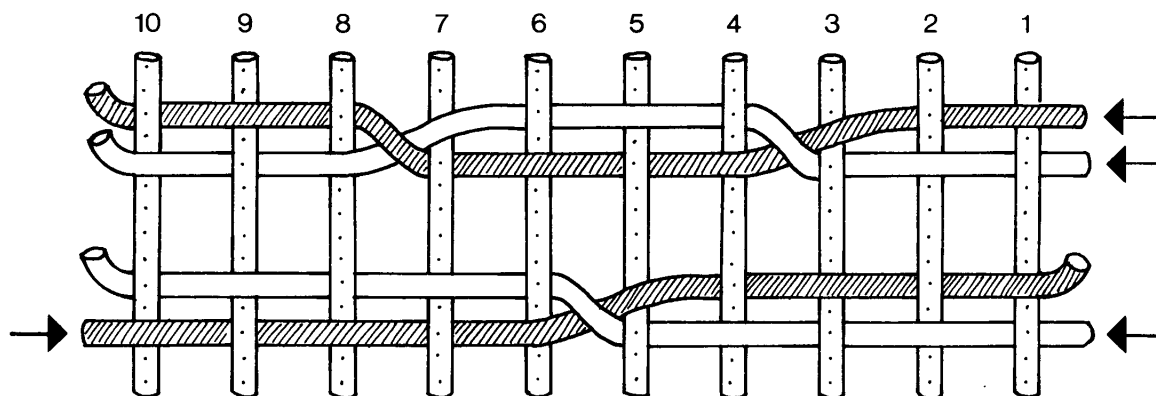

Fig.11

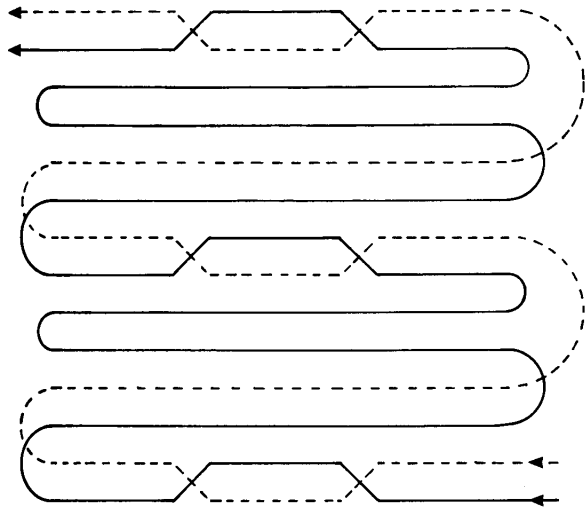

Fig.12

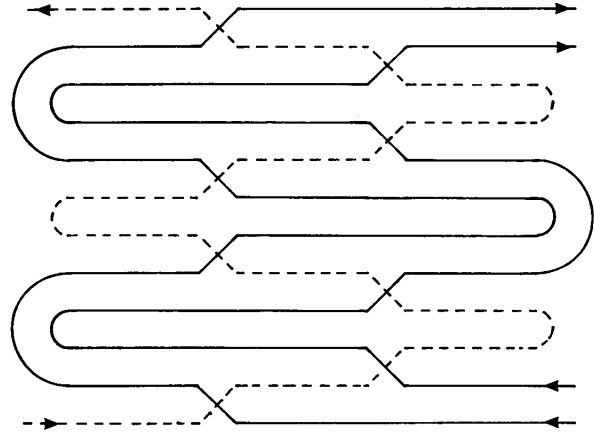

Fig.13

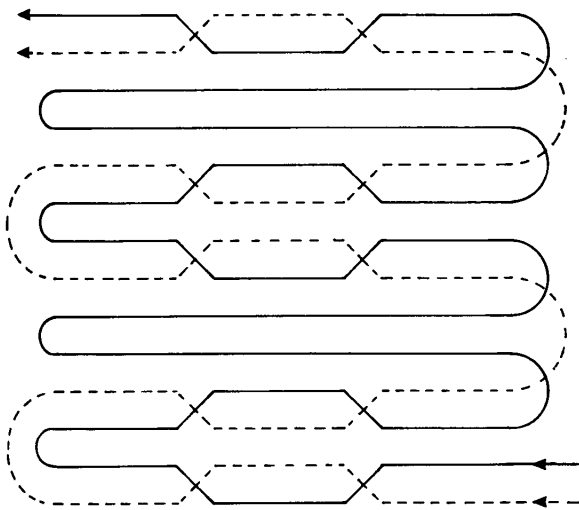

Fig.14

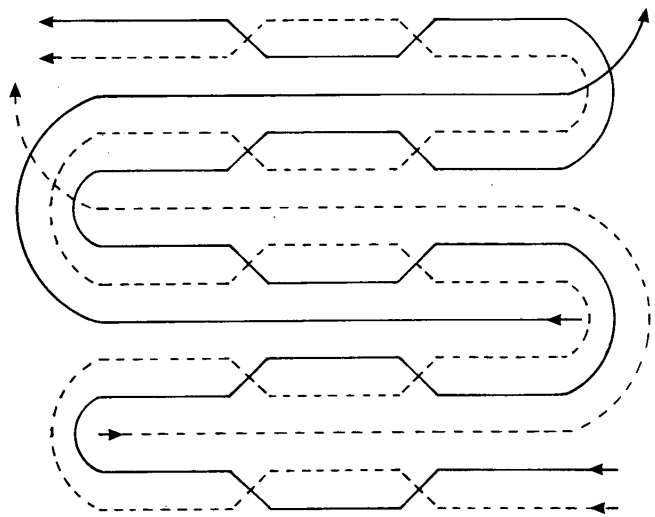

Fig.15

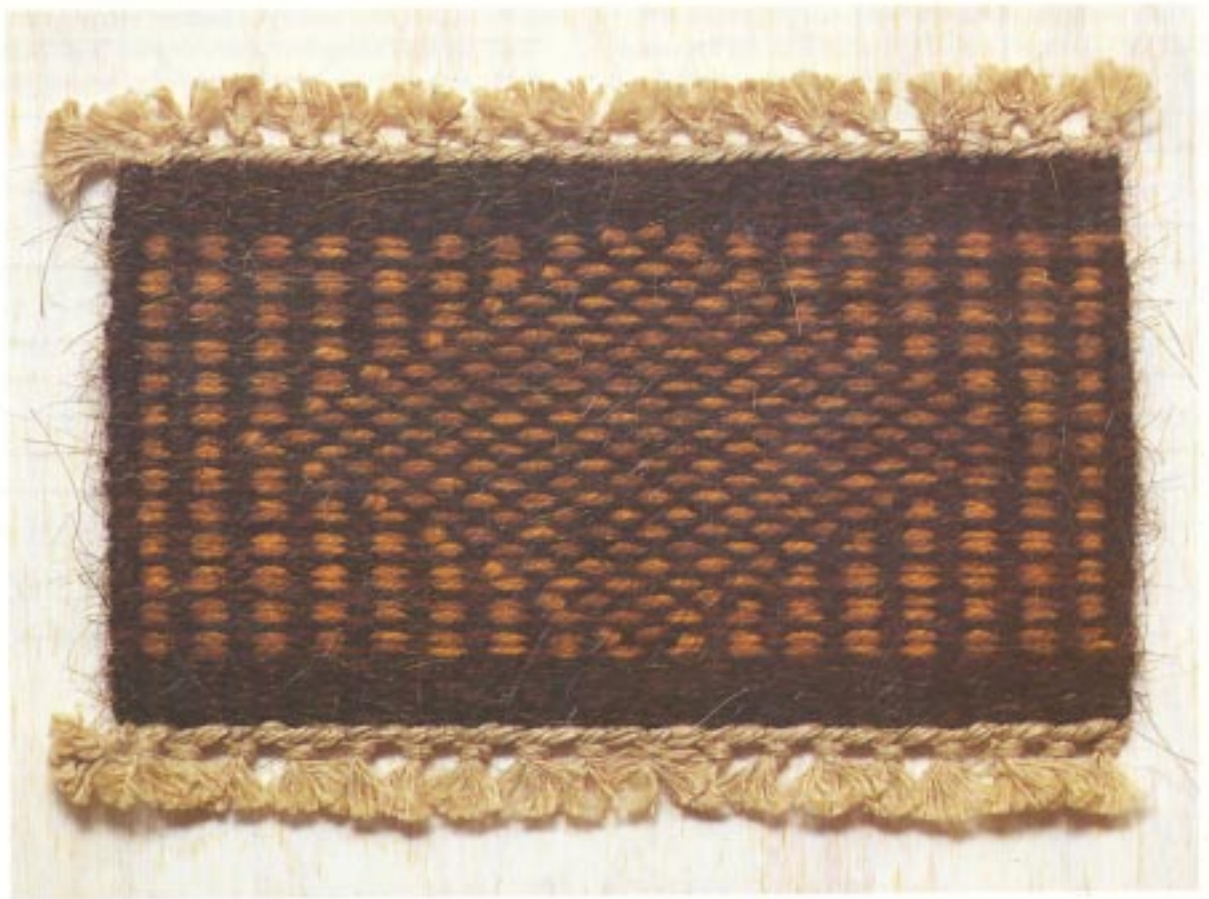

Plate 4 (see p. 20)

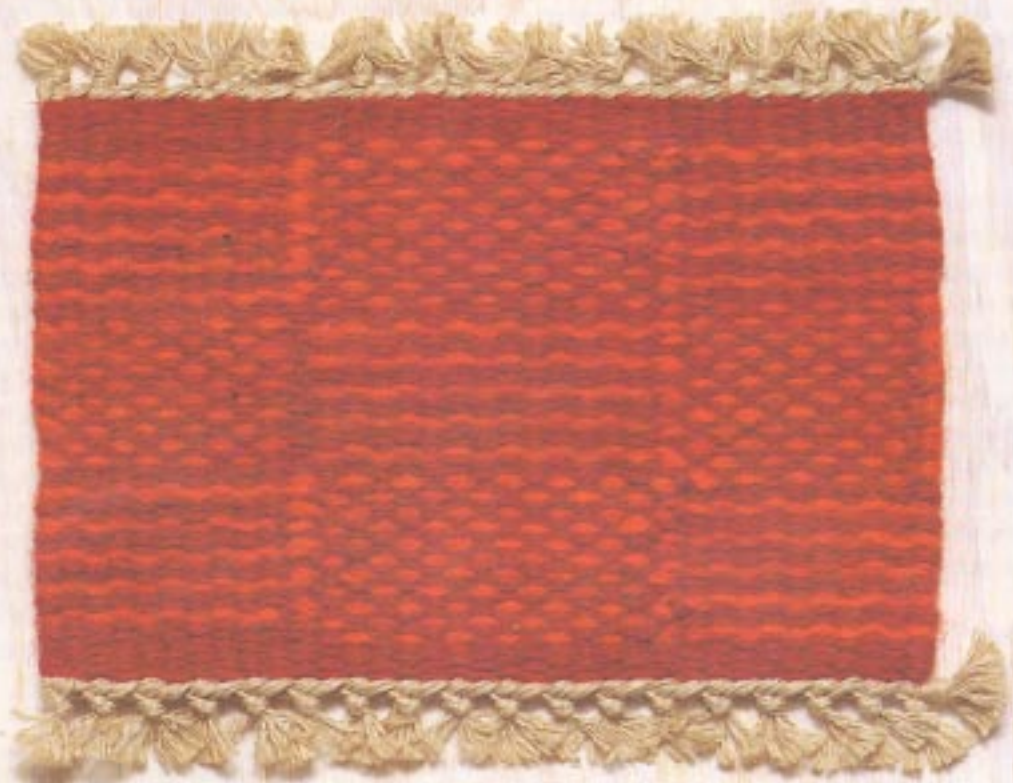

Plate 5 (see p. 20)

## Combining with Meet and Separate Weave

Combining Crossed Wefts with the principle of Meet and Separate Weave (i.e. a weft never reaches the opposite selvage but always returns to its own) leads to an interesting result, shown in *Fig. 16*.

Starting with wefts A and B at opposite selvages, bring them into the centre and then out of the shed.

Change the shed and cross them in the normal way, but take them out of the shed short of the selvage: A between raised ends 10 and 12, and B between 2 and 4.

Change the shed, take A to the right, bringing it out of the shed between raised ends 3 and 5, that is one end less far than B.

Change the shed and take A to the right selvage, noticing that it floats over two warp ends, 3 and 4.

Weave two more picks with A on ends 1 to 3.

Now bring B to the left selvage; as it enters the shed it ties down the float of A. Weave two picks with B on ends 12 to 14.

This is the complete cycle; two are shown in *Fig. 16*. Four picks have been woven in every area and the wefts are back

at their starting positions. Repeating this cycle exactly leads to four definite areas: solid colour A at the right and solid colour B at the left, with two areas between them showing cross-stripes and vertical stripes; see bottom of the diagram.

The 'jump' forward of A at the weft crossing and that of B over the float are of course invisible on the underside of the rug, which is therefore the front in use. See Plate 6 (p. 26).

Naturally, the three boundaries between the four areas can be moved at will. If the central crossing is moved alternately to right and to left, a new area is produced between these crossing points which shows a different sort of striping.

The colours can be counter-changed from side to side if, at the end of a repeat, B is woven all across to the right selvage and then A across to the left selvage and the normal sequence resumed. It will be found that this has no effect on the cross-stripe area, but that the vertical stripes move sideways one warp end; see one quarter of the way up the sample in Plate 6 (p. 26). To counter-change the areas of vertical and horizontal stripes, as in the upper half of the sample, weft A has to take a course analogous to that of B in the diagram and vice versa.

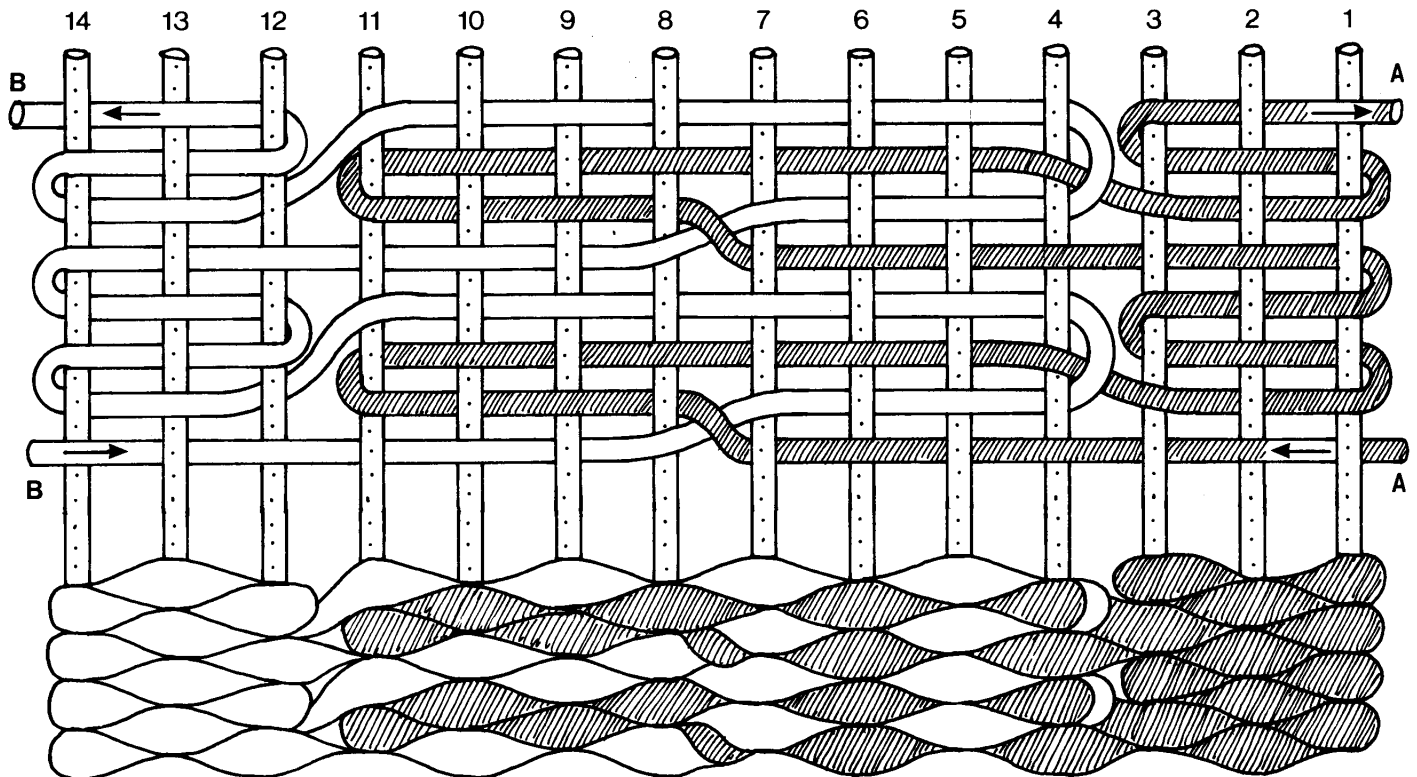

*Fig. 16*



## Weaving Incriptions

A good way to weave letters or figures into the end of a rug is to work a band of pick-and-pick stripes and alter the colours where necessary with weft wrapping. In Fig. 17(a), an E is imposed on such stripes. An X marks each portion which must have its colour reversed to produce the white E on a dark ground, seen in Fig. 17(b).

Starting at the bottom, the lower arm of the E is made by taking the white weft out of the shed, wrapping it around end 5 and returning it into the shed, in the manner shown in Fig. 18(b).

The dark weft follows in the next shed, passing normally from selvage to selvage, being hidden where the white is wrapping. The white wrapping pick is repeated to give the arm sufficient thickness; see the bottom of Fig. 18(c).

Now the dark pick has to emerge from the shed and wrap around end 4, as at Fig. 18(a), in order to give a solid dark area between the lower two arms of the E. The white weft is passed normally, being hidden by the dark wrapping. The central arm is worked exactly as the lower one, and so on.

An advantage of the method is that, if the rug is turned over, uninterrupted pick-and-pick stripes are seen instead of a mirror-image inscription as Plate 7 (p. 27) shows. It also avoids the long floats produced by the method described in TRWP. 124.

### Note

— It is best if all the wrappings are in the same direction, as in (a) and (b), even though the wefts forming them may be passing in different directions. Plate 7 (p. 27) shows such an inscription at the bottom with, above it, two decorative borders using the same technique.

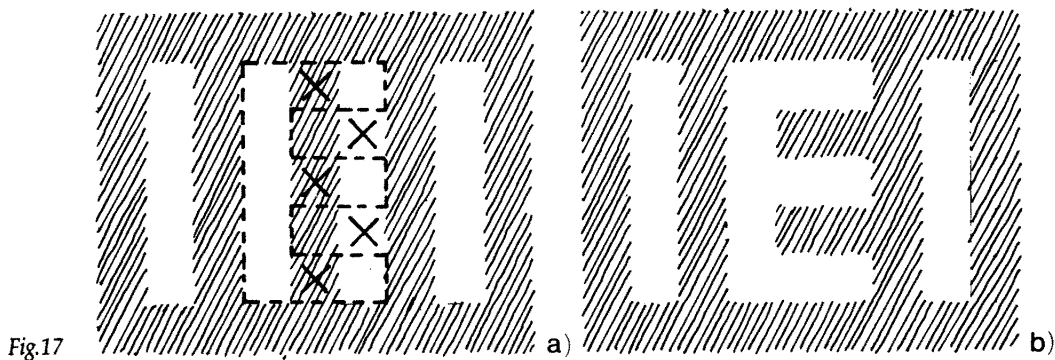

Fig.17

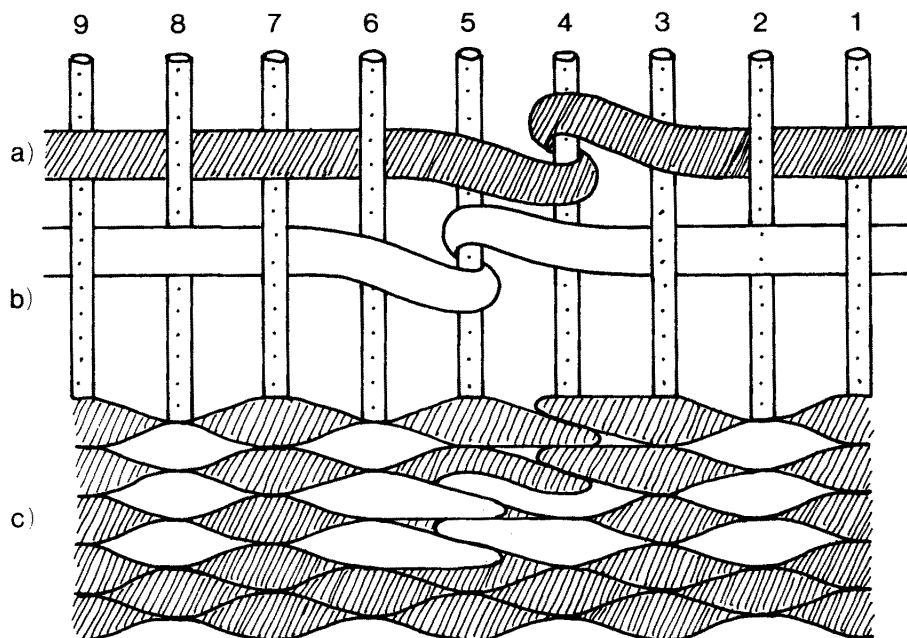

Fig.18



Plate 6 (see p. 24)

FRONT



BACK

Plate 7 (see p. 25)

## Clasped Wefts

The principle of Clasped Wefts can be applied to several different weave structures, such as plain weave, twill and the block weaves. In essence it gives picks made up of two (or more) colours, the extent to which each colour contributes to a pick being completely controllable. Wefts half the normal thickness *must* be used because, as Fig. 19 shows, they lie doubled over in each shed.

### Basic Method

Throw A (on a shuttle) from right to left, loop it around B (which can be on a ball or a cone, i.e. not on a shuttle) and then throw A back to the right selvage in the *same* shed. Pulling on A will drag a loop of B any required distance into the shed. Beat, change the shed and repeat.

The exact positioning of the clasping points between A and B is of course vital to whatever design is being woven, and is adjusted by pulling on the two free ends of weft. If, for example, the clasping points alternated regularly from side to side, as in Fig. 19, a rectangular central area of pick-and-

pick stripes would be created, with an area of solid A on the right and of solid B on the left.

The clasping points can be treated in two ways; either located *between* two warp ends, see lower pick in diagram (making it visible from both sides of the rug, but causing no lumpiness), or carefully located *under* a raised warp end in its shed, see upper pick in diagram (making it invisible from the front, but plainly visible as a little lump on the back of the rug). The first method is obviously more suitable for a reversible floor rug; the second for a rug intended for the wall. In either case, the technical difficulty is to combine an exact positioning of the clasping point with the normal loose waving of the weft.

Though the method can be used for free designs, the following, more ordered, applications work well and show some of its many possibilities.

### Using Two Wefts

Imagine the warp is divided by three lines (1, 2 and 3 in Fig. 20) and locate the clasping points at 1 for the first pick, at 2 for the second and at 3 for the third, and keep repeating this sequence.

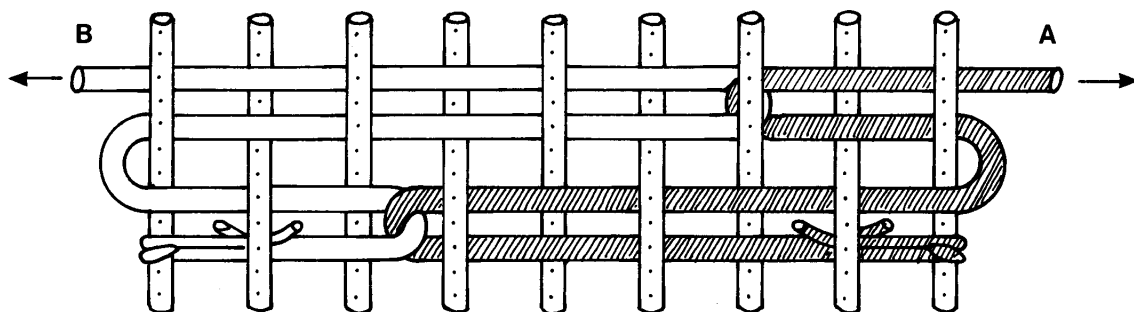

Fig.19

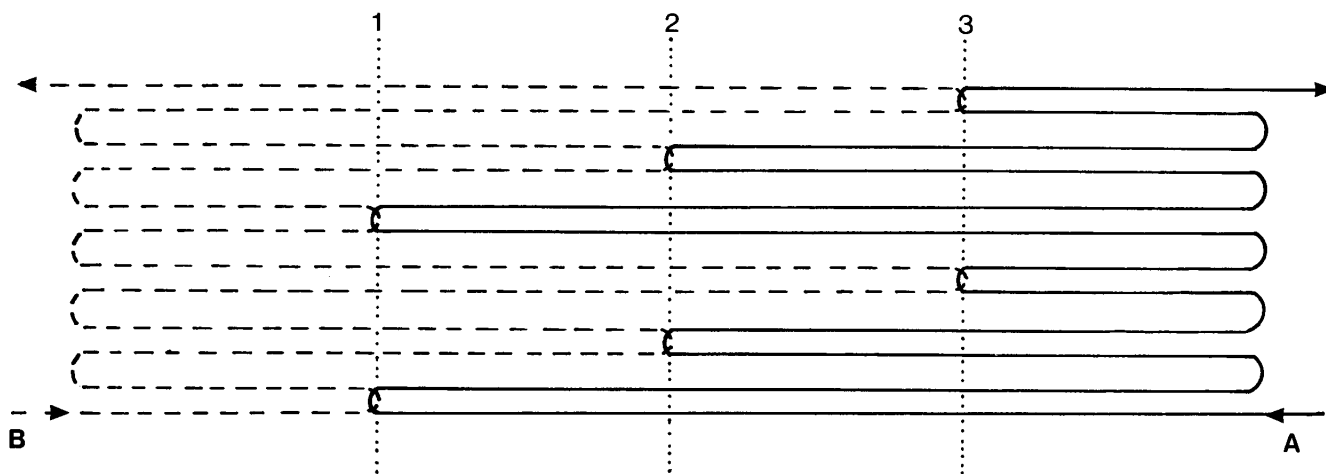

Fig.20

The result is an area of colour A at the right and of B at the left, with two spotted areas in between (one with spots of A on B, the other with spots of B on A); see *Fig. 20*. The spots are staggered, not arranged in vertical columns. As with all Clasped Weft techniques, the boundaries between the areas are movable. Plate 8 (p. 30) shows the result when lines 1 and 3 are inclined inwards.

In a similar way, imagine the warp divided by four lines (1, 2, 3 and 4) and locate the clasping points at 1, 2, 3 and 4 (as in *Fig. 21*) or at 1, 3, 2 and 4 (as in *Fig. 22*). The former gives

cross-stripes, the latter pick-and-pick stripes in the central area of the five areas produced. The spots in the two adjacent areas lie vertically above each other. There are areas of solid colour at both sides. Plate 9 (p. 31) shows both these possibilities.

Such regular ordering of the clasping points has many other variations, especially as different sequences can be combined and a clasping point can be located several times at one position.

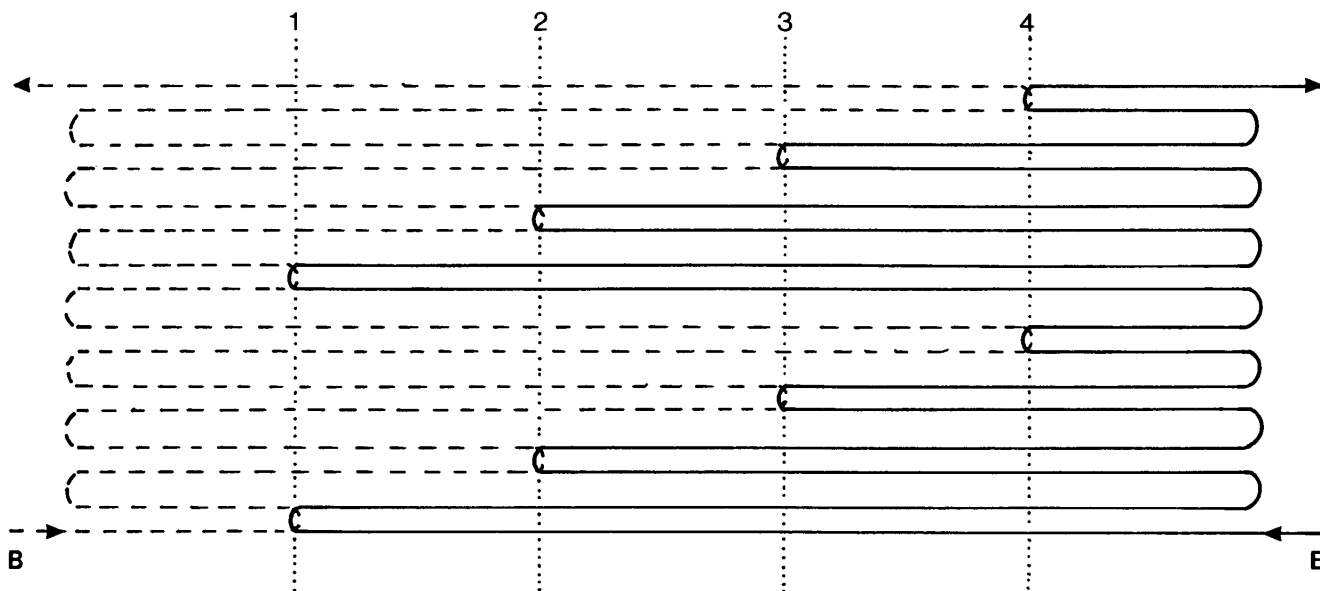

*Fig.21*

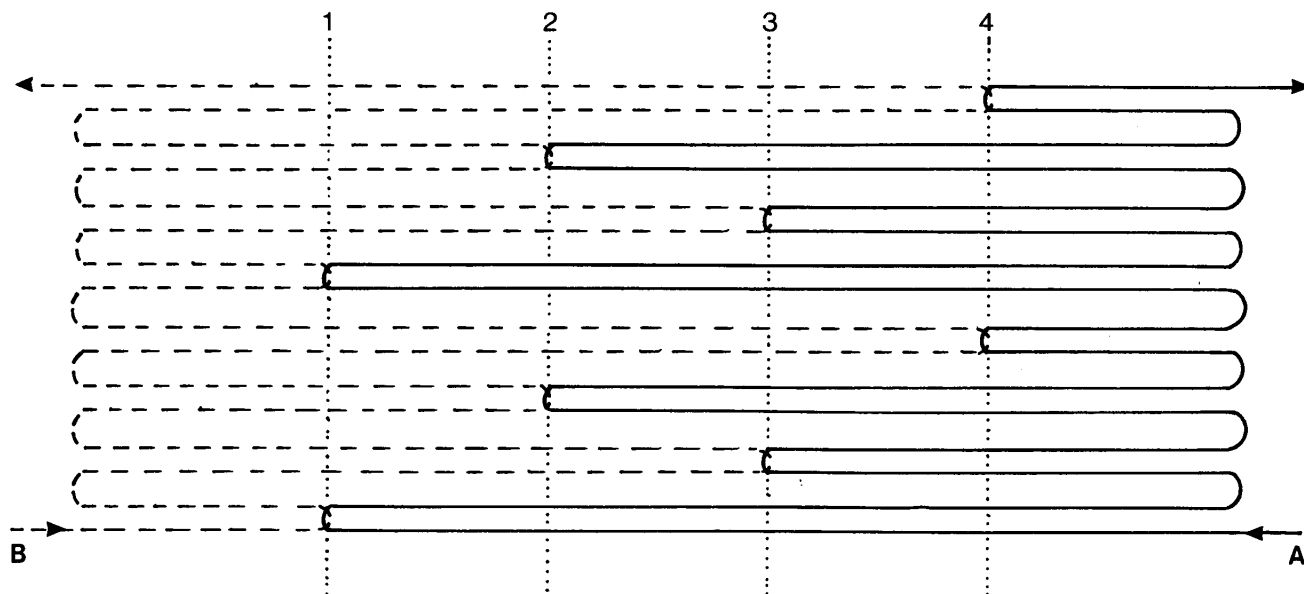

*Fig.22*

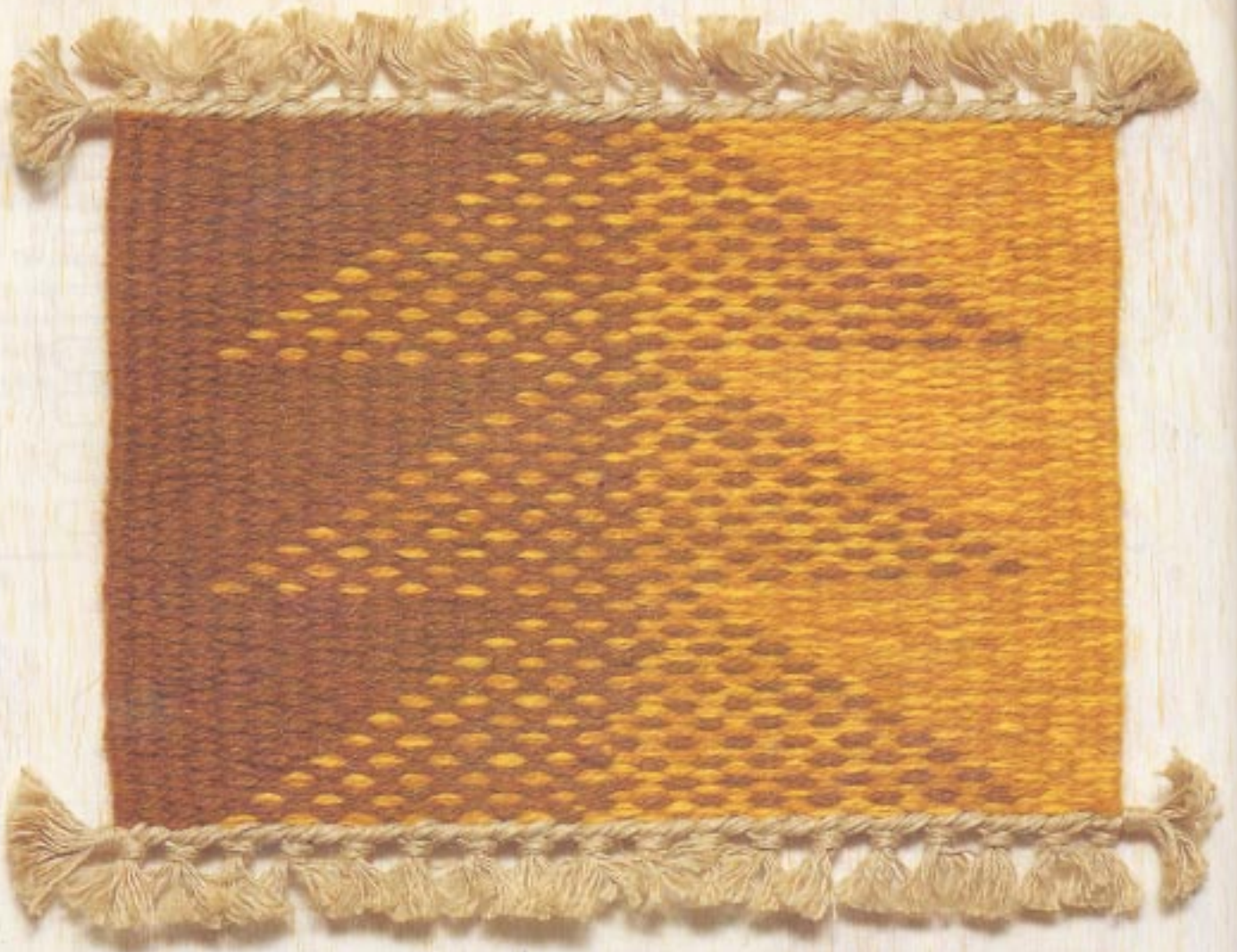

Plate 8 (see p. 29)

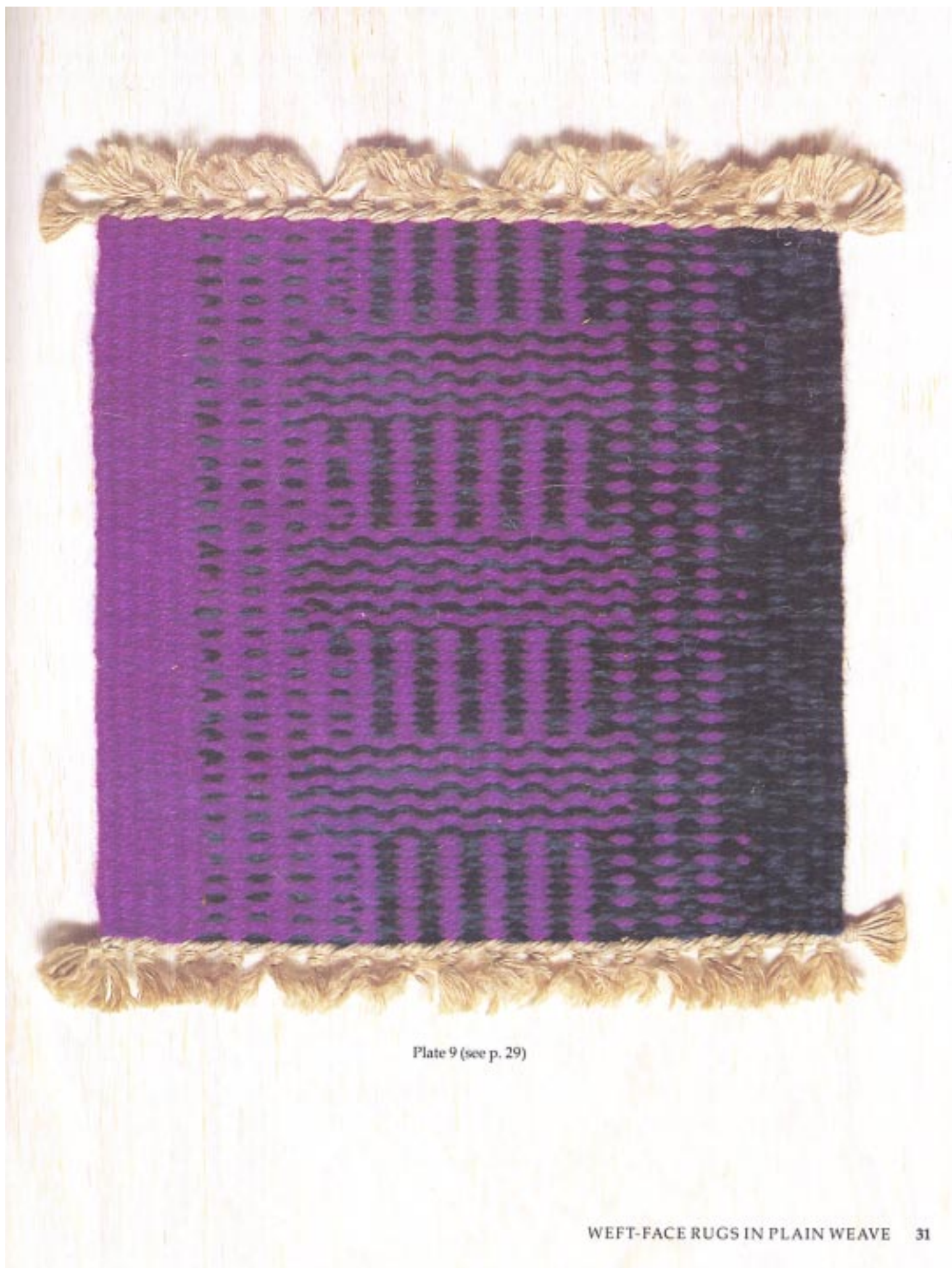

Plate 9 (see p. 29)

## Using Three Wefts

With a central shuttle carrying weft A and a ball of B at the right selvage and one of colour C at the left, the possibilities multiply; see Fig. 23.

Enter A into the shed, pass it to the right selvage, catch it round B and pass it all across to the left selvage, pulling in a loop of B. Adjust this right-hand clasping point and fix it with a light beat. Then catch A round C and pass it back to the centre and out of the shed, pulling in a loop of C. Adjust this left-hand clasping point and beat normally. Change the shed.

The problem of entering A into the next shed without it floating over two ends is solved thus. In the previous shed, it moved first to the right; in this shed move it first to the left, carrying it around a raised warp end as it enters the shed; see the lowest small arrow in Fig. 23. Keep this alternation of direction going, shed by shed. To avoid the sort of weakness at the centre seen in the diagram, make the point of entry move along a diagonal or a zigzag. Alternatively the weft can occasionally leave the shed by passing under the same end it passed under on entering the shed; see the heavy arrow at top of Fig. 23.

This will give three areas of solid colour A, B and C. If the clasping points are moved from side to side in some regular way, there will be striped areas between these. In Fig. 23 there will be pick-and-pick stripes between A and B, and cross-stripes between A and C. All these areas have a controllable shape; see Plate 10 (p. 34).

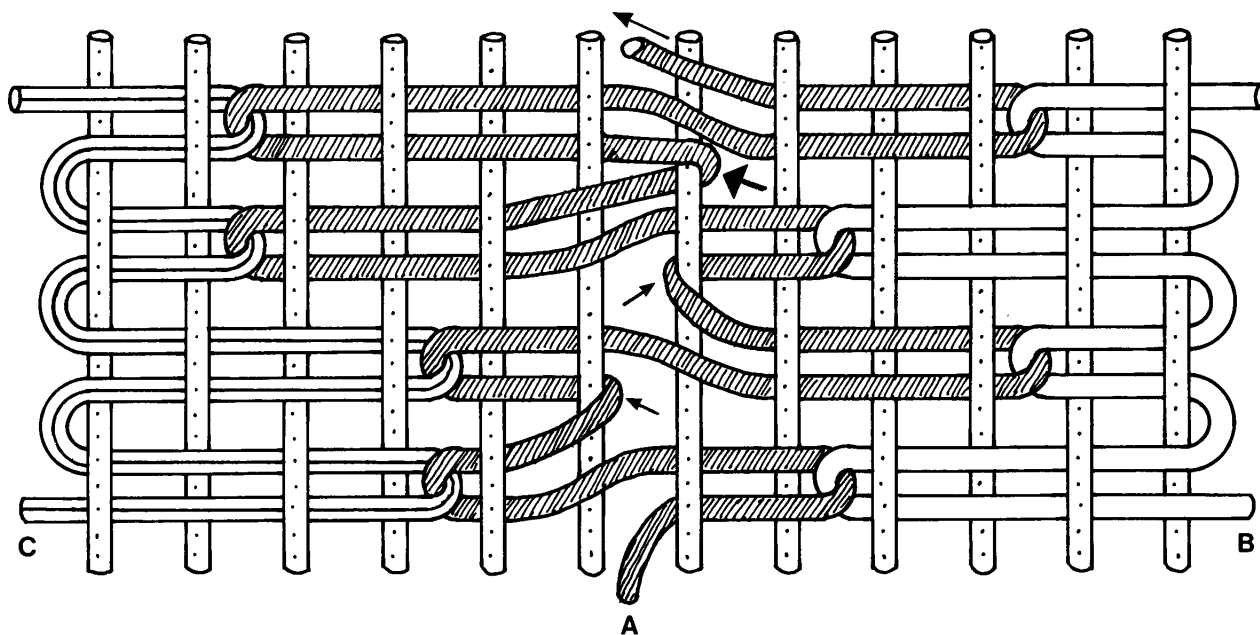

Fig. 23

## Using Four Wefts

One of the many ways four wefts can be handled is shown in Fig. 24. Shuttles carrying colours A and B lie at the left selvage, and balls of colours A and B at the right.

Throw shuttle A, pick up a loop of B at right selvage and throw it back, drawing B as far as required into the shed. Now throw shuttle B and draw a loop of A into the next shed; see first two picks in Fig. 24.

This will give pick-and-pick stripes of A and B at either side, with a central area which can be solid A (as at bottom of diagram) or solid B (see top pick) or any type of striping of the two colours, this area having a controllable shape; see Plate 11 (p. 35). Developments of this include using three or four colours, not just two; and using shuttle A for two picks, then B for two picks, or some such sequence, so striping other than pick-and-pick is woven at the sides.

### Notes

- A Grierson selvage is used at the left and a Navajo 1 selvage at the right.
- Because the wrapping of the selvage end is with half-thickness yarn, it may have to be done more times at both selvages than shown in the diagram.
- One incidental advantage of all Clasped Weft methods is that the yarn coming from a ball is theoretically endless, thus it never has any joins and darning-in is avoided.



## Compensated Inlay

Applying the idea of weft inlay to a weft-face textile imposes two conditions:

1. There must be two picks of the inlay weft to keep a correct shed sequence
2. The main weft must take a zigzag course as it passes from selvage to selvage in order to preserve a straight fell to the rug.

Fig. 25 shows these conditions being fulfilled and also shows that the area of inlay can be either striped (bottom) or spotted (top), depending on the presence or absence of an extra pick of the main weft. There follow some additions to the many possibilities of this technique described in TRW pp. 133-40.

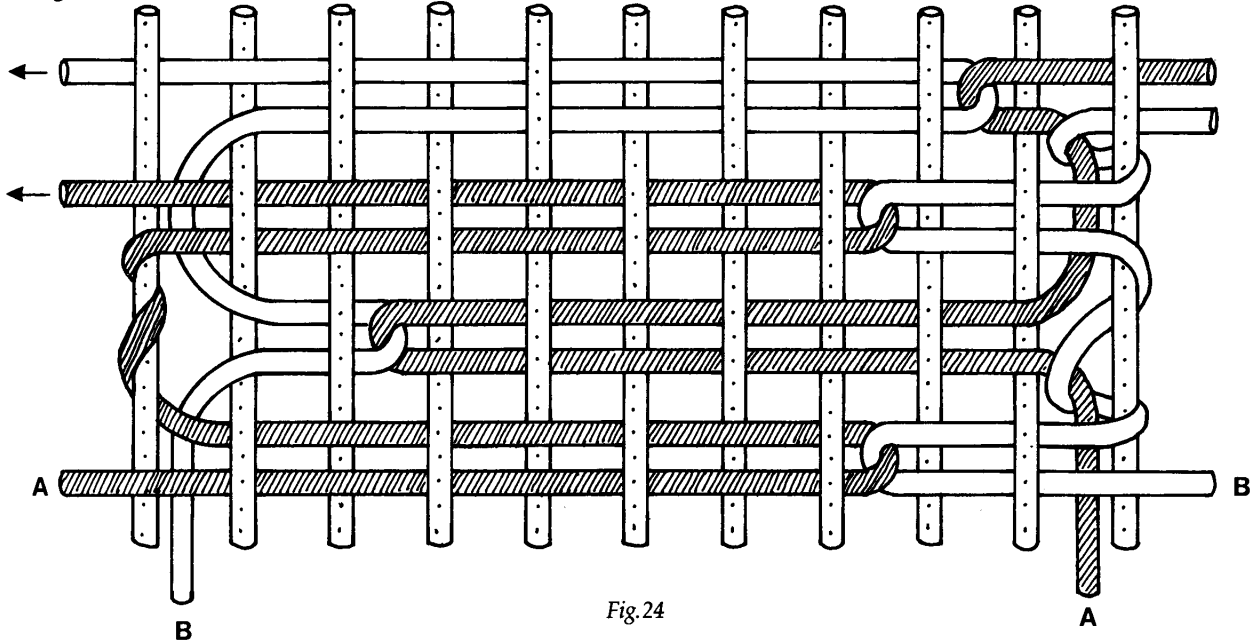

Fig. 24

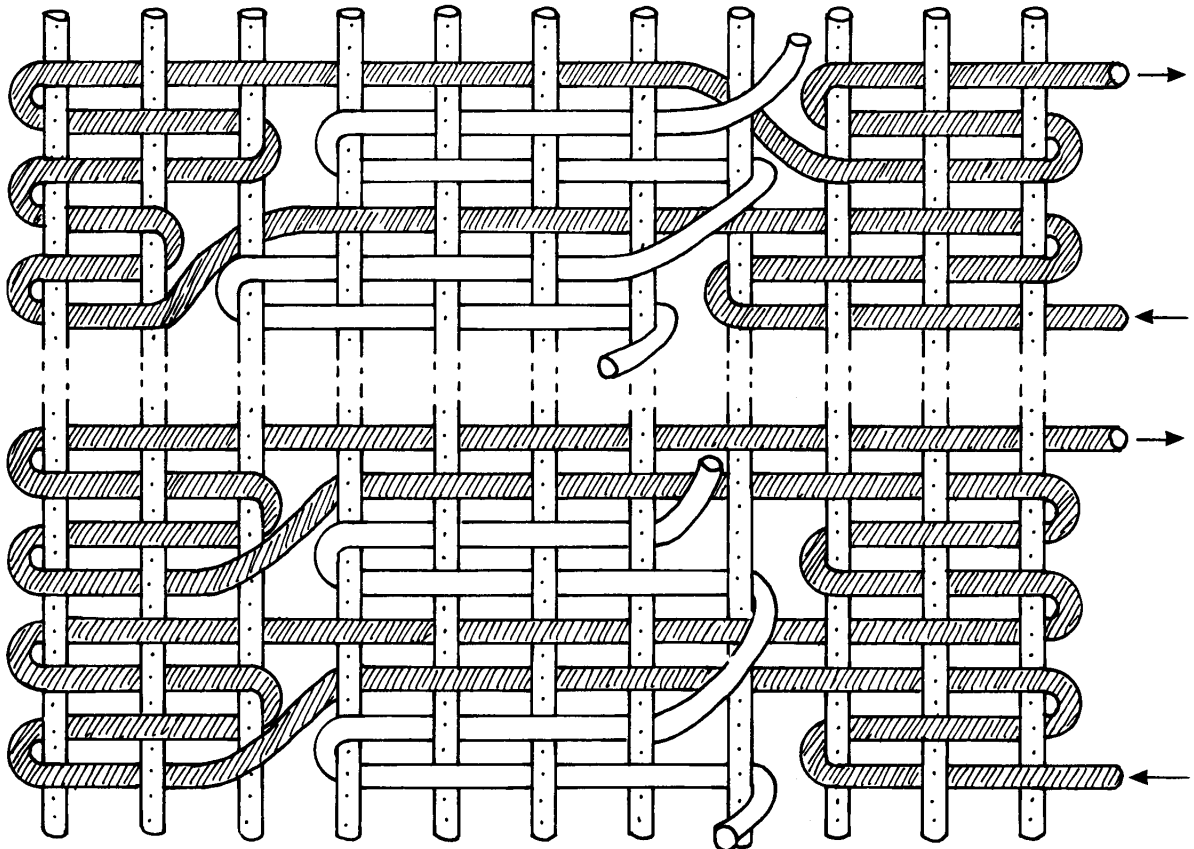

Fig. 25



Plate 10 (see p. 32)



Plate 11 (see p. 32)

### Striped Block with Inclined Edge

Though the 'jumps' forward from one pair of inlay wefts to the next in a striped block naturally give it a vertical edge, a convincing inclined edge can be woven as shown in *Fig. 26*; see Plate 12 (p. 38).

### Working the Centre of a Block with Two Inlay Wefts

If the two wefts are not to cross each other at the centre of a block, there tends to be a weakness where they both 'jump' forward, over the main weft, to their next pick.

In a striped block this can be overcome by inclining the 'jumps' forward alternately to right and to left, as in *Fig. 27*; see Plate 13 (p. 38), bottom.

In a spotted block, one weft 'jumps' forward vertically, the

left-hand one at bottom of *Fig. 28* going behind a raised warp end, and then the other weft enters the shed by going over and around the same end (number 4 in diagram). At the next repeat, roles are reversed, and the right-hand weft goes behind end 3 and the left-hand around it. This makes a good central feature when the two inlay wefts are of a different colour; see Plate 13 (p. 38), top.

If the two wefts are to cross at the centre of a striped block so that the colours change sides, the one that moves first has to float over two ends, but this is immediately tied down by the weft that moves second; see *Fig. 29*, lower crossing. If the two wefts are pushed through to the back before the main picks are woven, then crossed in a similar way as they are brought back into the appropriate shed, the crossing will now show on the back only; see top of *Fig. 29*. The first of these two possibilities was used in Plate 14 (p. 39).

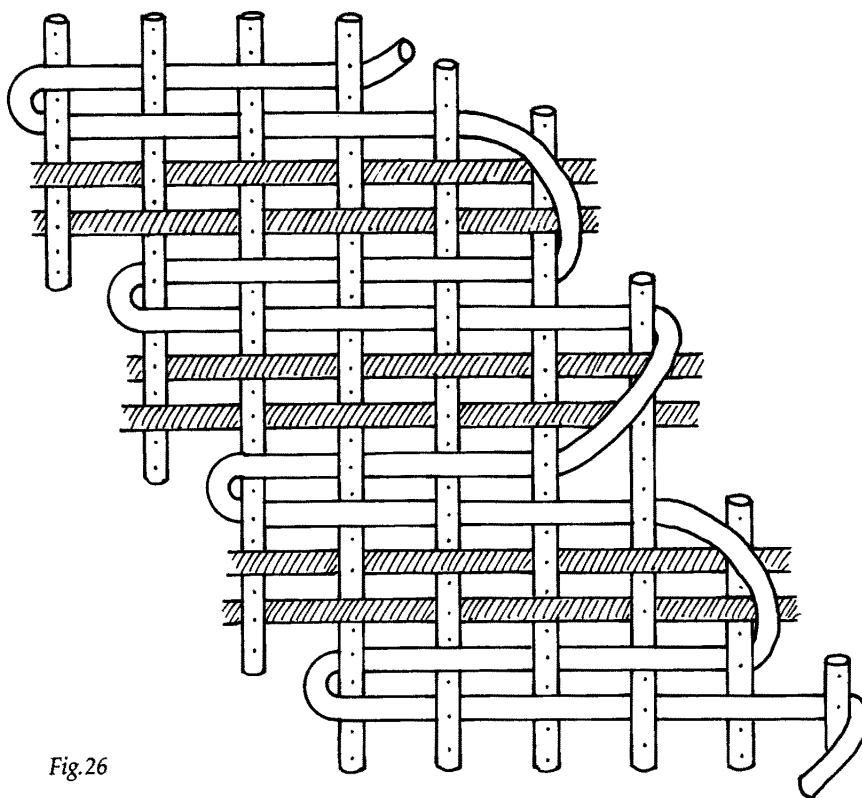

*Fig. 26*

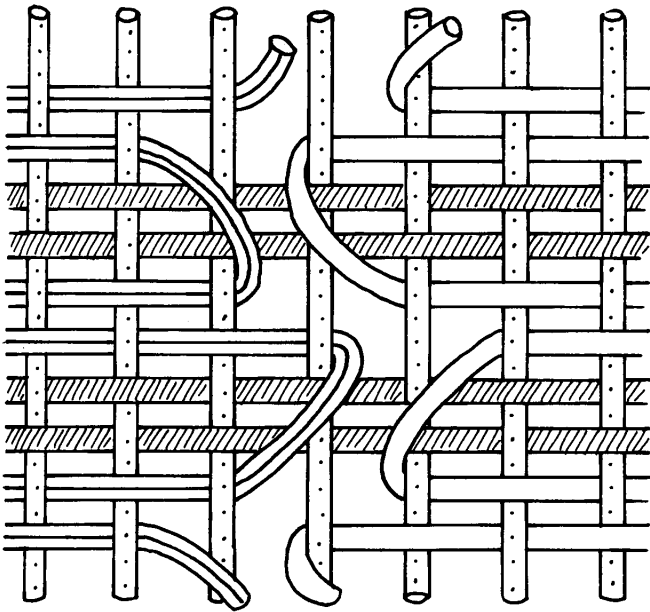

Fig.27

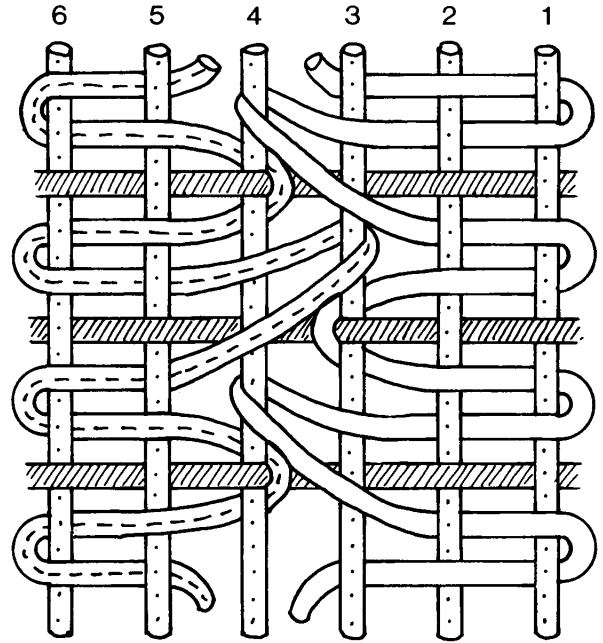

Fig.28

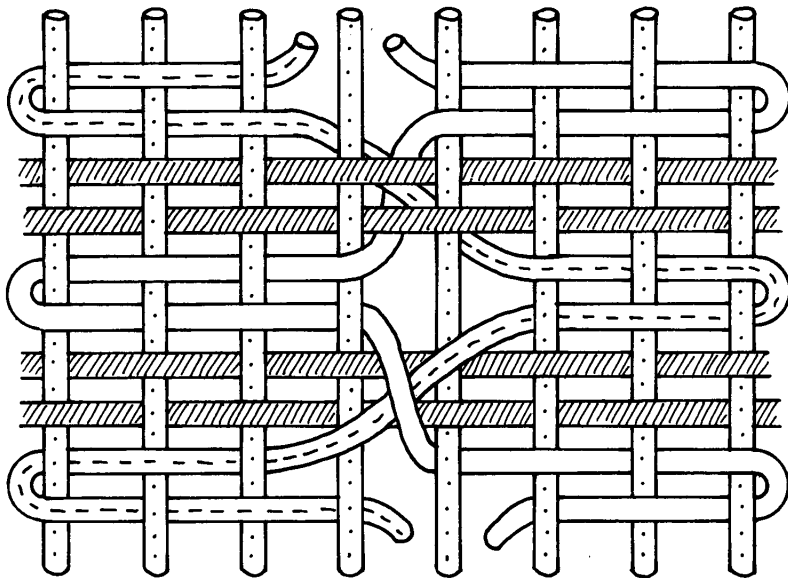

Fig.29





Plate 14 (see p. 36)

## Using Clasped Wefts for the Inlay

In another example of combining two techniques, the inlay block is woven thus:

Start with a weft of half the normal thickness at both outer edges of the block. Take one, say the right-hand, weft across the width of the block, catch it around the other weft at the left side, return to the right side dragging in a loop of this other weft, placing the clasping point where desired. Change shed and repeat this procedure. Now weave the main weft.

In *Fig. 30*, a spotted block is being woven with angled edges, so as the inlay wefts go into the next shed they both 'jump' forward over two warp ends as shown.

There are two advantages to using clasped wefts. First, the forward 'jumps' are half the normal thickness so they do not make the usual raised ridge and the rug is truly reversible. With an angled edge as described, they become part of the block and do not register as floats. Second, colour sequences not normally possible in the centre of the block are easy to work; see *Plate 15* (p. 42).

## Combining Spotted Blocks with Pick-and-pick Stripes

Weaving several inlay blocks, all from one weft (TRW p. 139) preceded and followed by a band of pick-and-pick stripes (as in *Plate 16* on p. 42), gives yet another way of effectively combining two plain-weave techniques. *Fig. 31* shows the details. Note that there is an odd number of ends in each inlay block.

## Block with Vertical Stripes

A newly worked-out form of compensated inlay disobeys the first condition laid down at the start of this section, because the inlay weft is inserted in single picks, not pairs. This gives a block of vertical pick-and-pick stripes, as in *Plate 17* (p. 43). The inevitable problem of maintaining the correct shed sequence is overcome as follows:

Lay in a single pick of inlay weft, A in *Fig. 32(a)*. Between it and the selvage where the ground weft is not emerging (i.e. the right selvage in the diagram), insert a small section of ground weft, weaving with ends 1 to 4. In the diagram this has been conveniently done with the tail of the ground weft which is assumed to have started here. It could equally well have been a small separate length of ground weft.

Now, in the same shed as the inlay weft, weave the ground weft B to the right and bring it out of the shed in the same warp interspace (between raised ends 9 and 11) as the emerging inlay weft; see *Fig. 32(b)*.

Change the shed. Enter the ground weft in the new shed and carry it all the way to the right selvage, noticing that it floats over two ends, numbers 9 and 10.

Change the shed. Enter the inlay weft vertically above, so that it ties down this float and carry it as far as required by the design to the right, as in *Fig. 32(b)*.

Alternately take it over the float then *under* one warp end to the left, number 10, and then into the shed. See *Fig. 32(c)* where it is seen there is the familiar crossed weft formation. This method is neat but is visible on the back and front, whereas the first method gives one faultless surface (the back as woven) and one surface with visible 'jumps' forwards.

*Fig.30*

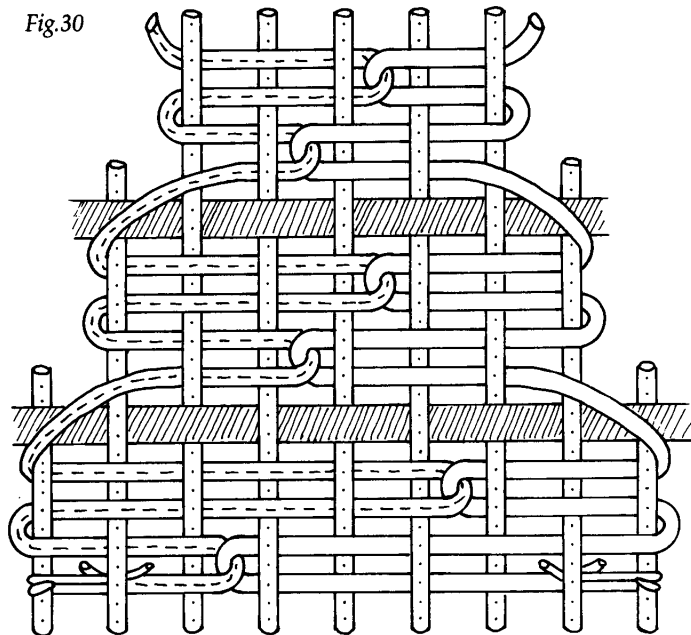



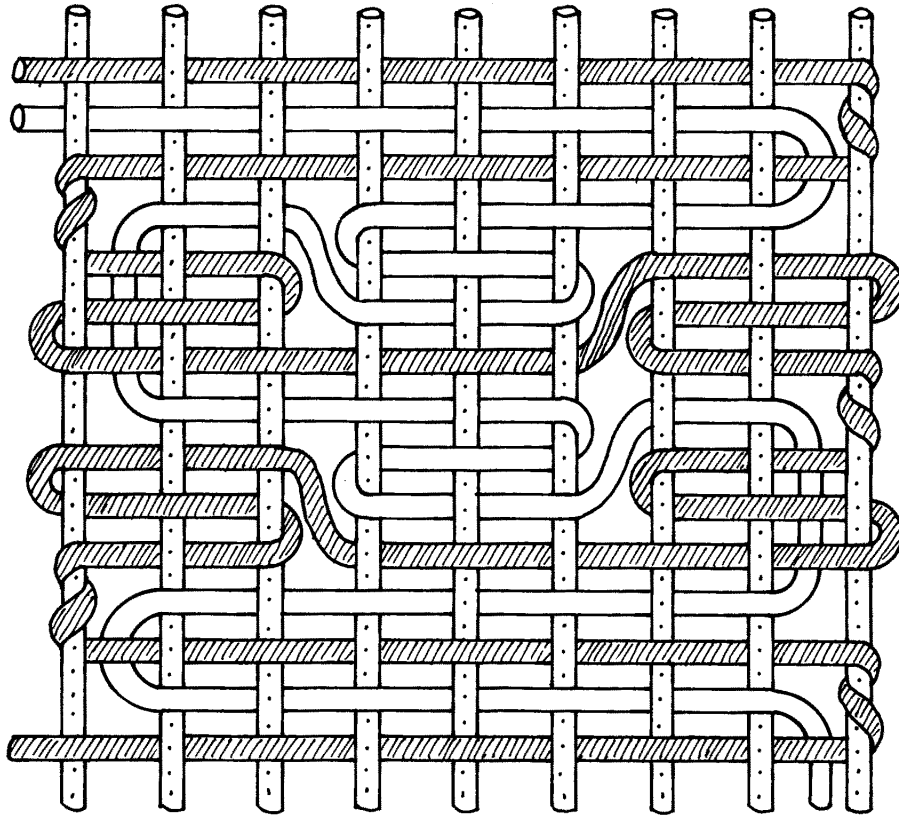

Fig.31

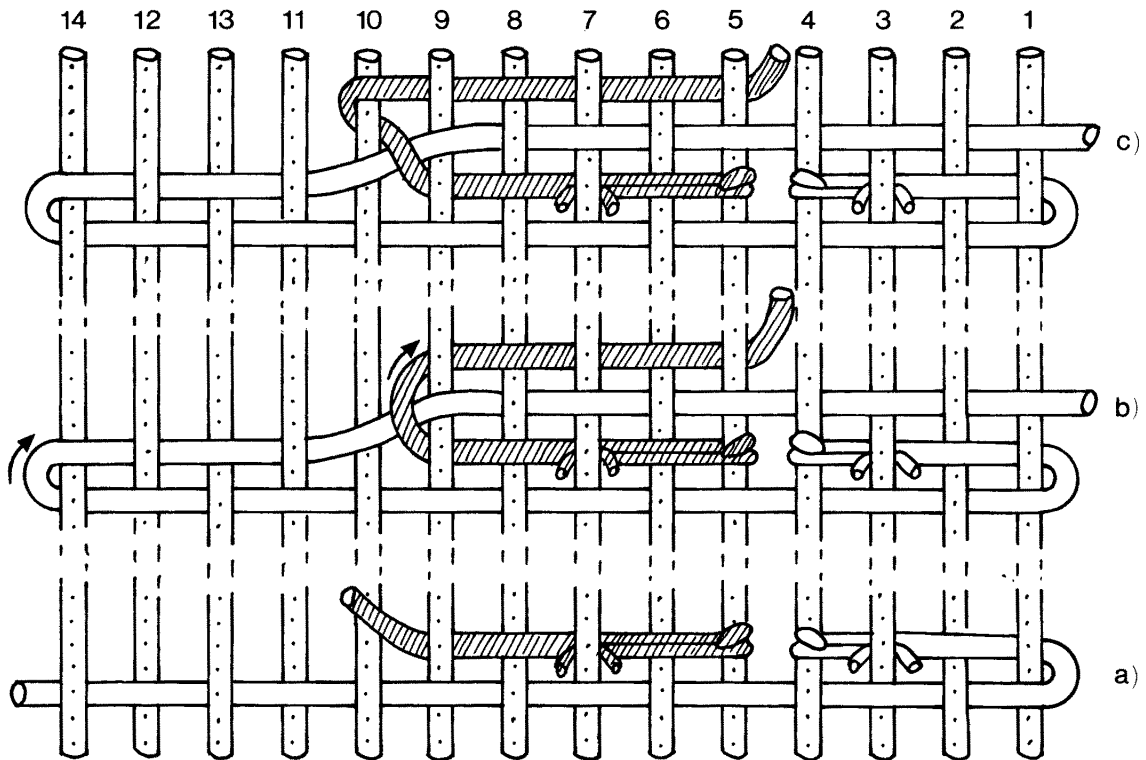

Fig.32

Plate 15 (see p. 40)



Plate 16 (see p. 40)



Plate 17 (see pp. 40,44)

A similar procedure is now followed on the right: i.e. bring the ground weft up to the inlay's emerging point, change the shed and carry it to the left selvage, and so on.

To compensate for the single picks of inlay, make the ground weft take the usual zigzag course only as it starts its journey from the selvage. So its route is as shown schematically in Fig. 33. To avoid confusion, these compensatory picks have been omitted in the main description and diagrams.

The inlay area can be altered in size at every pick, i.e. as it moves to the right it can go as far as desired in that direction, and similarly in the next pick to the left. In Plate 17 (p. 43), it has been moved inwards or outwards after every four picks. A possible variation is to weave three inlay picks instead of one, giving a cross-stripe. This was done at the centre of the sample in Plate 17 (p. 43) and, of course, requires more compensatory picks of the ground weft.

## Combining Skip Plain Weave with Tapestry

Skip Plain Weave, in which two wefts use the same shed but pass in and out of its back layer (so where one lies *in* the shed the other *floats* at the back), is sometimes combined with tapestry weave. If the motif in Fig. 34(a) was woven entirely in tapestry technique, six wefts would be needed at level A – A. By using Skip Plain Weave for the narrow areas, the number is reduced to two, but with the disadvantage of having some weft floats at the back.

As Fig. 34(b) shows, each weft weaves normally at either side, but dives in and out of the back layer of the shed at appropriate points in the centre. Here where the dark weft lies in the shed, the white floats at the back, and vice versa. So it is only those parts heavily outlined in the diagram which will show on the surface; see the compressed view at bottom of diagram.

## Pick-and-pick Stripes in Tapestry

Some Navajo rugs, from Coal Mine Mesa near Tuba City, Arizona, have triangular or rhomboidal areas of pick-and-pick stripes. The way the two alternating wefts are handled gives floats over two warp ends at one or both edges of such areas; see the left-hand edges in Fig. 35. The floats combine to form a slightly raised ridge, lying obliquely between adjacent areas, hence the name, 'Raised Outline', given to this style, which dates from the 1930s.

Even when an area consists of a single colour, two wefts are still used, so a ridge is produced; see the outer areas in Fig. 35.

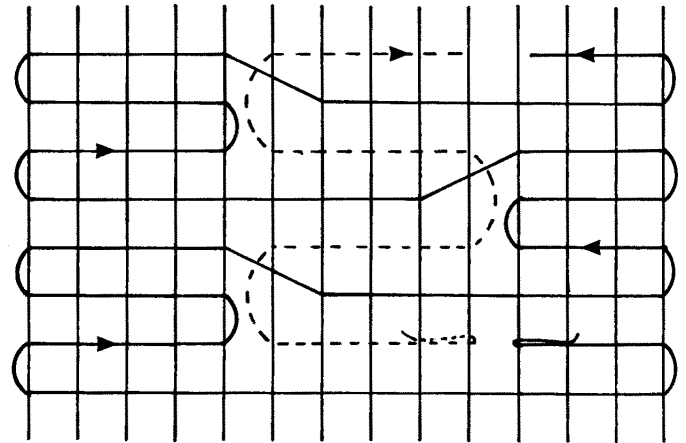
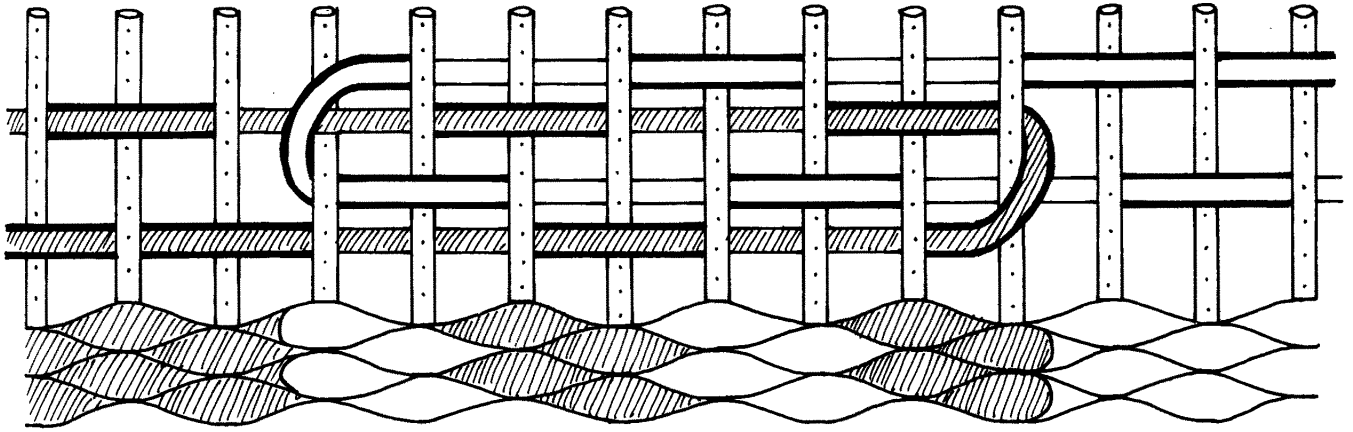

Fig.33



b)

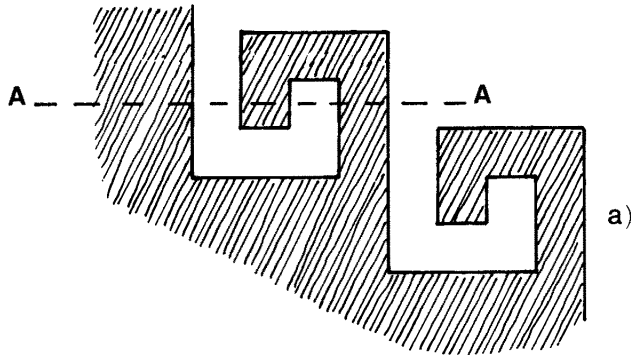

Fig.34

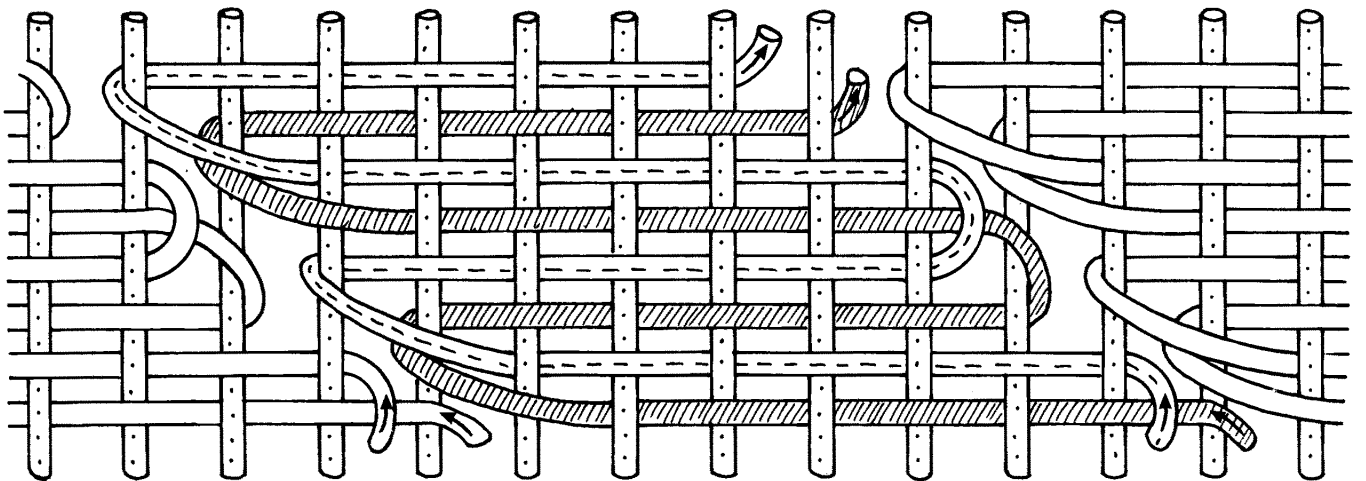

Fig.35

FRONT



BACK



# Weft-face Rugs in Multishaft Weaves

Once interlacements more complex than plain weave are used for weft-face rugs, the character of the work changes. There is much less manipulation of the weft in the interests of design; it often passes without interruption from selvage to selvage. Instead, the designs result from what the shafts do to the warp, rather than what the fingers do to the weft. This greater reliance on the loom's intrinsic capabilities, on what it can give the weaver, has two linked results. There is an increase of speed when weaving, but a reduction of freedom when designing. The latter effect, though seeming a drawback, can actually become a benefit. It can stimulate ingenuity and channel the weaver into working out and weaving designs which might not otherwise have been envisaged.

## Double-faced 2/1 Twill

A straight three-shaft draft, lifted for a double-faced 2/1 twill, gives a very useful rug structure. Two repeats of the draft are shown in Fig. 36, with a sequence of the six lifts different to the one previously given (TRW p. 260). It will be seen that each warp end stays up for three picks, then down for the next three picks.

As the odd-numbered picks (heavily outlined and shaded) show only on the front and the even-numbered only on the back, the front and back of the rug can be completely different.

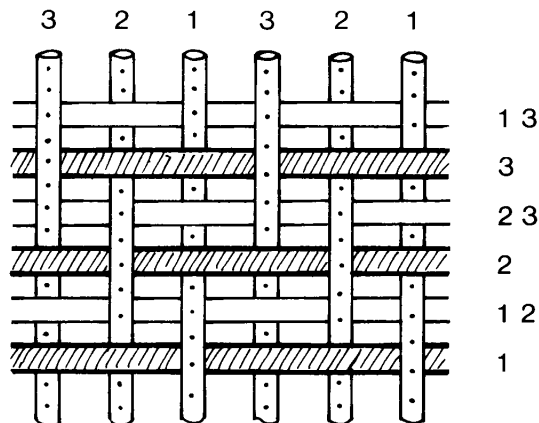

Fig.36

The following are some possible colour sequences to use and the results they give.

1. (A,B,A,B) The rug has colour A on the front and B on the back.
2. (A,A,B,B) The rug has oblique stripes of A and B on the back and the front, the stripe lying on the opposite diagonal to that of the structural twill.

To reverse the direction of these oblique lines, the lifting sequence must naturally be read in the opposite direction, i.e. downwards instead of upwards. But to make a good transition, miss out two of the lifts.

The sequence becomes as follows, the arrows showing the reversing points:

1,12,2,23,3,13, ↓ 2,12,1,13,3,23, ↓ 1,12,2,23,3,13,

The (A,A,B,B) colour sequence continues unaltered throughout.

3. (A,A,B,B,C,C,B,B) This gives identical oblique stripes on the front and the back of the rug, a stripe of B alternating with a mixed stripe of A and C.
4. (A,B,C,A,B,C) This gives vertical stripes of the three colours on the back and the front.
5. (A,D,B,D,C,D) This gives the same vertical stripes, but only on the front, the back being solid D colour.
6. (A,C,B,C) This gives stripes of A and B on the front with solid C on the back; see Plate 18 (left).

## Practical Details

Like other three-shaft weaves, this twill presents no problems when woven on a jack or countermarch loom. The difficulty with a counterbalanced loom can be overcome by making a simple harness from two flat triangular pieces of wood; see Fig. 37. Each has a central hole for a suspending cord and a hole at each corner for cords running down to the three shafts. It will be understood that when any one shaft is pulled down by a pedal, the other two shafts will automatically rise, and when any two are pulled down, the other one will rise; so the six desired lifts are easily obtained. In the past, such wooden equilateral triangles, found only in Scandinavia, were thought to be for tablet-weaving.

A warp set at 4 working epi works well with a weft of 2-ply carpet wool used two-fold, i.e. a little thinner than is usual for other weaves set at 4 epi.

The wefts will not always catch naturally at the selvage in this weave, so a floating selvage should be used. The first and last end of the warp, which is probably doubled or tripled, is not threaded on a shaft but passes normally through the reed. When a shed is made, these two selvage working ends stay horizontal and do not move. The shuttle enters the shed passing over the floating selvage and leaves the shed passing under the opposite floating selvage; thus the weft always catches the outermost end at both sides. Working in this way, there will be occasional weft floats over three ends at the selvage. But because the warp ends are set a little closer at the selvage, this 3-span float is only slightly longer than the 2-span floats in the rest of the weave. If desired, however, it can be avoided by taking the shuttle under instead of over the floating selvage, or vice versa, at appropriate points in the sequence.

When using the (A,B,C) colour sequence, starting all three wefts at the same side gives a good selvage.

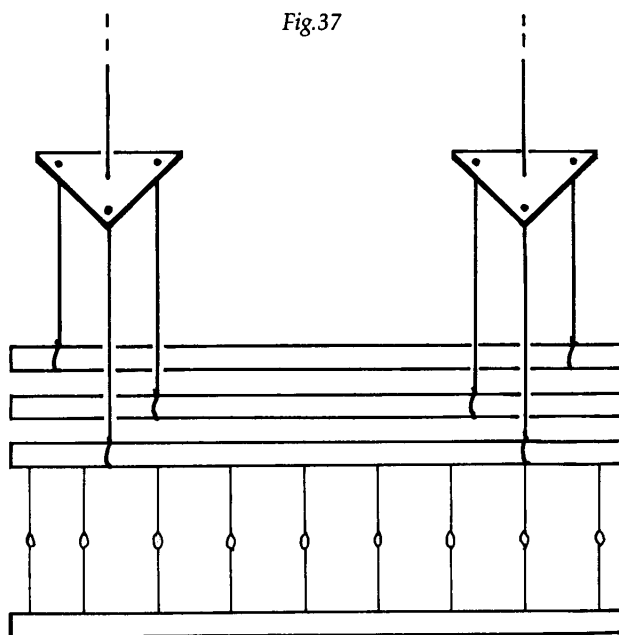

Fig.37

## Using Clasped Wefts

Applying the Clasped Weft principle to this twill makes it possible to have a central block of oblique stripes with an area of solid colour on either side. Fig. 38 shows how the three picks in the lifting sequence which appear on the front of the rug would lie. On the right is a shuttle of half-thickness weft A, on the left a ball of half-thickness weft B. The three picks appearing on the back (not shown) could be another colour altogether and, not being clasped, would, of course, be of normal thickness.

The method is worked as follows:

Lift shaft 1, throw weft A to the left going *under* the floating selvage (FS at top of Fig. 38), both as it enters and as it leaves the shed. Catch it around weft B and throw it back to the right, drawing a loop of A as far as required into the shed. Again it must pass under both floating selvages.

Lift shafts 12, throw normal weft for back surface of rug.

Lift shaft 2, throw A to left but this time going *over* the floating selvage both as it enters and leaves the shed, pick up a loop of B and return to the right.

Lift shafts 23, throw weft for back surface.

Lift shaft 3, throw A to left going *under* the floating selvage both as it enters and as it leaves the shed. Pick up B and return.

Lift shafts 13, throw weft for back surface.

Continue in this way, always taking A alternately over and under the floating selvages, so that the clasped wefts always catch around them at both sides, as in Fig. 38.

If the clasping points continue to be moved from side to side as shown, there will eventually be an area of solid B on the left, one of solid A on the right and in the centre the alternating picks of A and B will give oblique stripes; see Plate 19. (p. 50)

Naturally this central area can be any shape as its outer boundaries are dictated by the positions of the clasping points. If these are always placed under a raised warp end, the shape will have a convincing and crisp edge. The clasping points will not appear on the back of the rug, as the weft floats there will cover them. The back of the sample (see Plate 19) is solid red.

If both the front and back picks are woven with the two clasped wefts, the rug will be the same back and front, but it may be hard to conceal the large number of clasping points. In addition the outer areas of solid colour are made as narrow as possible, this provides a simple way of weaving oblique stripes, or any other two-colour pattern in the centre, without any selvage problems. Fig. 39 shows one way the six picks could be arranged. On both the back and the front of the rug, the central area will show oblique stripes of A and B flanked by a narrow border of solid A on the right and of solid B on the left. Plate 20 (p. 51) shows a sample based on this idea, with the colours counter-changing at the borders but the central area remaining constant.



*Note*

— This twill can be woven on a warp threaded for the Three-end Block Weave. If shafts 3 and 4 are always lifted together, the block weave threading, however the blocks may be arranged, acts as a straight three-shaft draft. So the lifts become:

1, 12, 2, 23, 3, 34, 134

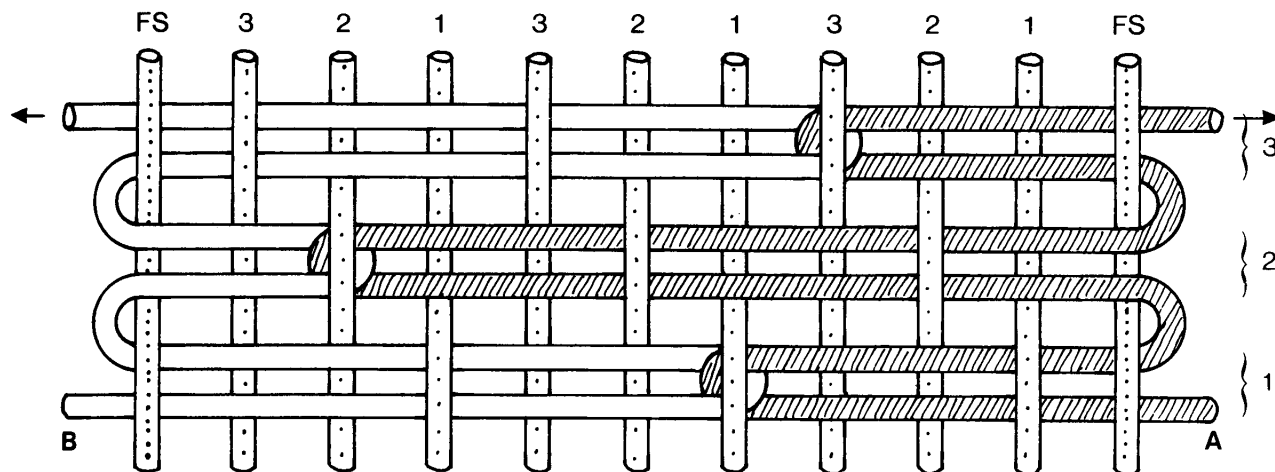

Fig.38

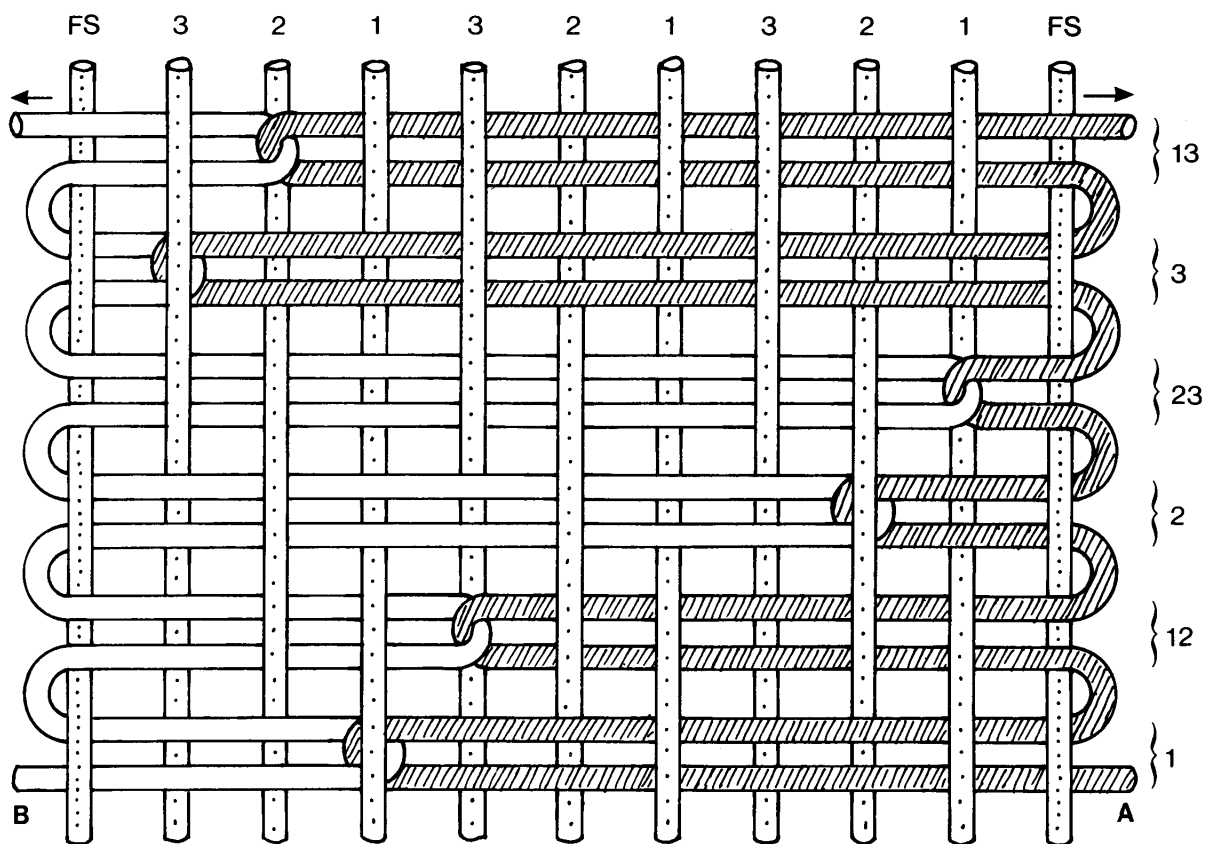

Fig.39

FRONT



BACK





Plate 20 (see p. 48)

## Three-shaft Krokbragd

This rug weave has become popular because, despite its simple structure, it gives endless possibilities in design and colour combinations. Fig. 40 shows the threading draft and the lifts. It weaves well with a warp of 4 working epi and a weft of carpet wool used two-fold. The only problem it presents is at the selvages, especially as the weft colour sequences are frequently changed. But this can be overcome by following these rules.

1. Always use *three separate wefts* (A, B and C in Fig. 41(a)), even if three actual colours are not needed in the design. If only two colours are needed, two of the wefts must be the same colour.
2. For each repeat of the three lifts, throw all three wefts in the *same direction*; from right to left in Fig. 41(a). In the way the lifts have been arranged in Fig. 40, the last one thrown across is the colour which covers the selvedge end, threaded on shaft 1. This is important.
3. In the next repeat, throw A and B normally, noting that they miss the selvedge completely and 'jump' forward on the back; see Fig. 41(b). To compensate for this, wrap weft C around the selvedge end, in a downward direction, before it is thrown; see diagram. The number of wraps, perhaps two or three, should be just sufficient to create a level fell.

This will make a perfect front to the rug. The 'jumps' forward of wefts A and B on the back will be visible, though partly hidden by the long floats of C at this point.

The right-hand selvedge is handled in exactly the same manner, which, it will be seen, is really just another application of the Grierson Method for a pick-and-pick selvedge.

If the selvedge end is floating and not threaded on shaft 1, wefts A and B will enter and leave their sheds under the floating selvedge, and weft C will leave a shed under it, wrap and then enter over it. The selvedge of the three-colour part in Plate 32 (p. 67) was handled in this way.

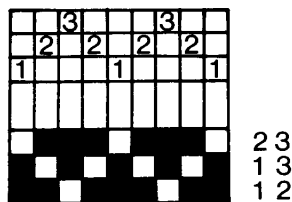

Fig.40

## 2/2 Twill

A straight or broken 2/2 twill gives a good weft-face rug structure, which can be patterned with many more small-scale designs than are possible with the above three-shaft twill. The two sides of the rug are always identical. With a warp set at 4 working epi, a weft of 2-ply carpet wool used three-fold is suitable. This setting will make the small motifs repeat every inch across the width of the rug, as they are of necessity four warp ends wide.

To the many weft colour sequences already described (trw pp. 272-8), the following can be added.

### Straight 2/2 Twill, Lifted (12,23,34,14)

1. Nine-pick sequence: (A,A,B,B,A,A,B,A,B).
2. Twelve-pick sequence. So that the colour sequence coincides with the familiar triangular motif, start thus: (A,A,A,B,A,A,B,B,A,B,B). An oblique band of these triangles is seen in Plate 60 (p. 127).
3. A variant (A,A,A,B,A,A,B,A,A,B,B) converts the triangles into arrow shapes.
4. Using three colours in the sequence (A,A,A,B,A,A,B,B,A,B,B:A,A,A,C,A,A,C,C,A,C,C,C) gives a vertical row of colour A triangles, followed by a row of triangles alternately in colours B and C.

### Broken 2/2 Twill, Lifted (12,23,14,34)

An interesting interlaced pattern is obtained with the sequence (A,B,A,B,A,) × 2, (A,C,A,C,A) × 2; see Plate 21 (p. 54).

All the patterns possible with three-shaft Krokbragd can be produced using various four-pick colour sequences with a broken twill. But unless a thin weft is used and beaten very hard, the colour areas are not so crisp and clean-edged. Of course, the design will be identical on both sides of the rug, unlike Krokbragd.

## Skip Twills

In Skip Twills, ends in the normal straight draft (1,2,3,4) are missed (skipped) in a regular way as the shafts are threaded. Then when a known colour sequence is used, the expected pattern is sometimes elongated in the weft direction and sometimes completely altered. The same principle can be applied to the four normal lifts, skipping some in a regular order. For instance, skipping every fifth lift gives:

(12,23,34,14, 23,34,14,12, 34,14,12,23, 14,12,23,34)

or skipping every third and fourth alternately gives:

(12,23,34, 12,23, 14,12,23, 14,12, 34,14,12, 34,14, 23,34,14, 23,34).

These lifts can then be tried with any colour sequence. As an example, the first one with the twelve-pick sequence gives the expected triangles but they occur in rows leaning to one side; see Plate 22 (p. 54).

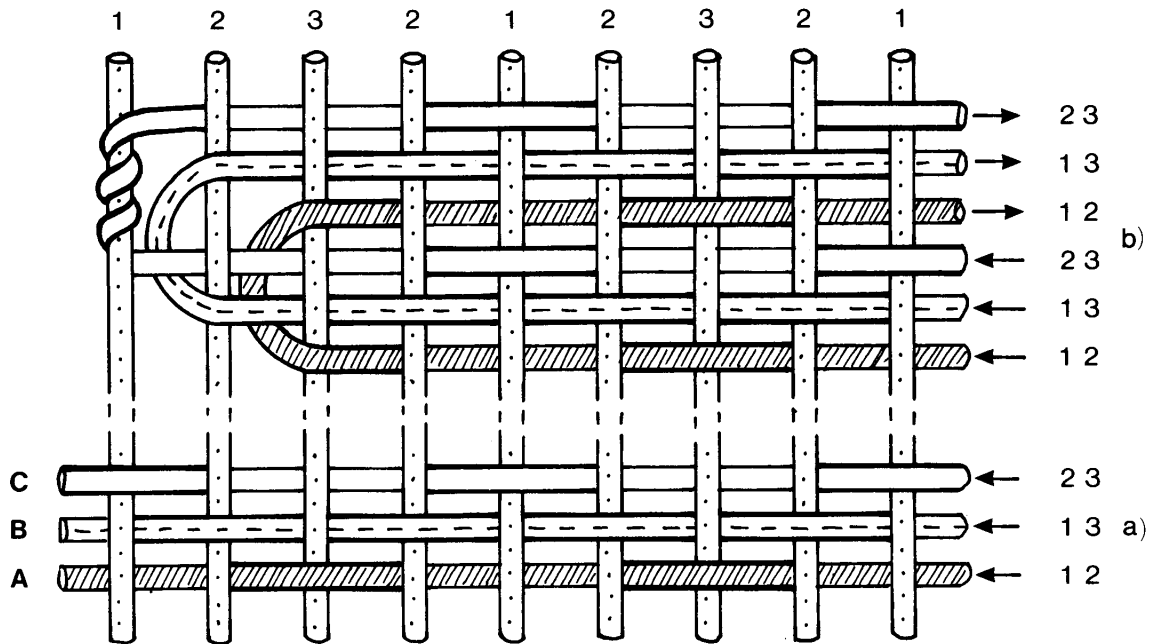

Fig.41

Plate 21 (see p. 52)



Plate 22 (see p. 53)



Plate 23 (see p. 56)

## Crossed Wefts

Applying the principle of Crossed Wefts in Contrary Motion to broken 2/2 twill can give a central area of wide vertical stripes with side areas of spots vertically aligned. Two wefts start from opposite selvages, either on the 12 or the 14 lift of the broken twill sequence, and pick by pick alternate their crossing points from side to side; see *Fig. 42*. At a crossing point, always first move the weft which will float over three warp ends, not five; then move the other weft tying down this float; see *Fig. 43*. Crossing twice at one side will make the vertical stripes counter-change, giving the appearance of checks seen in *Plate 23* (p. 55). The selvages give no problems, both wefts catching perfectly at both sides.

## Clasped Wefts

As with the 2/1 twill above, Clasped Wefts can be used with 2/2 twills. Using half-thickness wefts, one on a shuttle at the right selvaige, one on a ball at the left selvaige, every pick of the straight or broken twill sequence is woven with a Clasped Weft. Thus all the two-colour patterns, which normally run from edge to edge, can be localized in the centre of the rug in an area of any desired shape, with an area of solid colour on either side.

In *Fig. 44* the clasping points for six picks have been arranged so that the colour sequence is (A,A,B) in the centre, giving thick oblique stripes of A and thin of B. If three clasping points are used, as in *Fig. 20* (p.28), there will be two central areas, one with an (A,A,B), one with an (A,B,B) colour sequence, so oblique stripes of the two types can be woven side by side; see *Plate 24* (p. 58).

Use a floating selvaige, always taking the shuttle over it on both sides in one pick, and under it on both sides in the next pick; this gives a perfect selvaige.

Unlike the 2/1 twill in which the clasping points can be hidden by the weft weaving at the back, here they will be plainly visible on the back or the front, depending how they have been placed.

The design is more convincing if the outline of the central area follows some feature in the pattern being produced, as in *Plate 24* (p. 58).

## Compensated Inlay

Another plain-weave technique, Compensated Inlay, works especially well with a 2/2 twill structure, giving a spotted block with an angled edge. *Fig. 45*, the general plan, shows that four picks of inlay weft is the unit, and the main weft, after taking its zigzag course from right to left, always returns to the right.



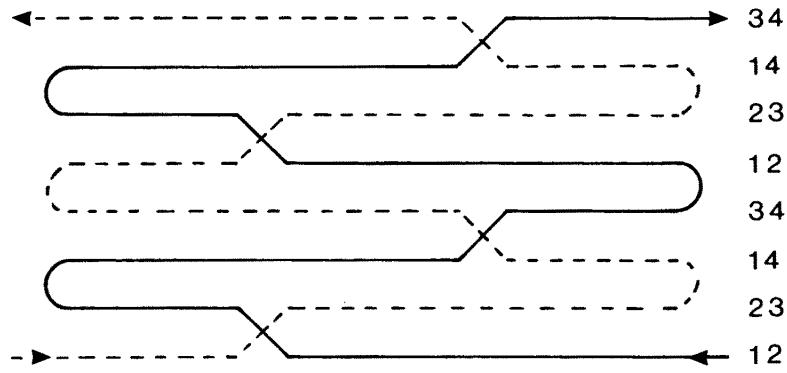

Fig.42

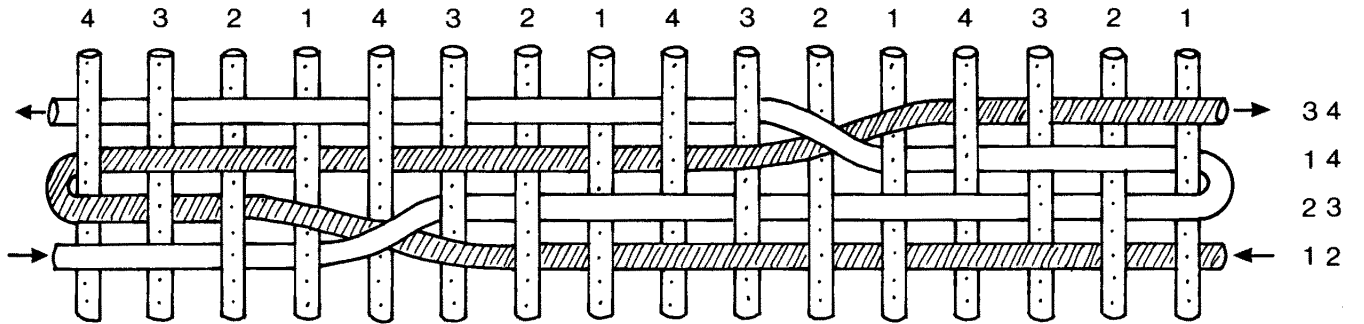

Fig.43

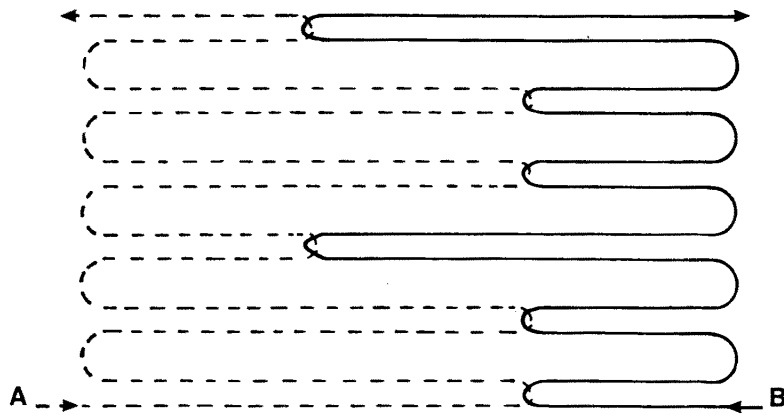

Fig.44

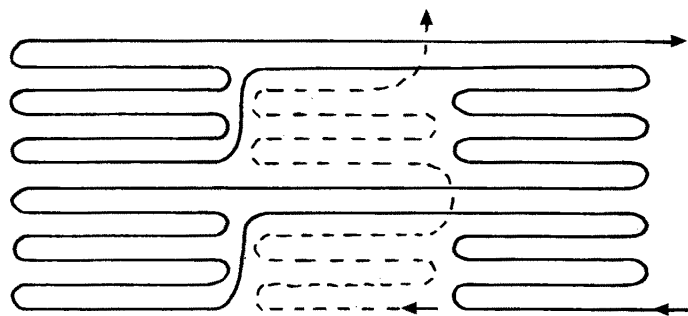

Fig.45

Plate 24 (see p. 56)



Plate 25 (see p. 60)



Plate 26 (see p. 60)

The method of work is as follows (see Fig. 46):

Lift 12, start the inlay weft (shaded) around an end on shaft 3 and pass it to the left as far as wanted.

Lift 23, take weft around end on 3 and pass it to the right.

Lift 34, pass the weft down between the raised ends on 3 and 4, throw it to the left, bringing it up between ends on 3 and 4.

Lift 14, take the weft around end on 3, pass it to the right and bring it out between ends on 1 and 4.

Weave the main weft; first four picks at the right, allowing the weft to encroach on the warp ends used by the inlay weft to avoid a slit, as shown in diagram. Then take it across to the left selvage and weave four picks there before returning to the right. This last pick was with 23 raised, so the method proceeds thus:

Lift 34, pass the inlay weft to the left over two warp ends and over the last two picks and into the shed. The block is shifting to the left, so take it two ends further to the left, as shown. The next three picks will be exactly comparable to those in the first inlay section.

Continuing in this way, the inlay area will steadily move over to the left; see Plate 25 (p. 58). Unlike the plain weave application, the weave is quite reversible as there is no discernible 'jump' forward between one inlay section and the next. At the 'jump' forward, the weft passes over two ends exactly as does a normal weft in 2/2 twill.

### Reversing the Twill Direction in a Block

The weave plan in Fig. 47(a) shows a 2/2 twill which in the outer areas inclines up to the left, and in the central area up to the right. This could of course be woven with a pointed draft as at Fig. 47(b) and with the normal (12,23,34,14) lifts. But it can be woven on a straight draft with the added advantage that the shape of the central area can be changed at will.

It will be seen that two of the picks, those when 12 and 34 are lifted (filled in black in diagram), go straight across and fit with both the twills. But for the other two picks (hatched), the shed has to be changed twice during the passage of the weft. The technique is worked as follows:

Put two markers, X and Y, in the reed to establish the boundaries of the central area.

Lift 12, pass weft A all across.

Lift 23, pass A to the first marker and take it out of the shed.

Change the shed to 14 (the opposite of 23).

Enter A and pass it to the second marker and again take it out of the shed.

Change the shed back to 23.

Enter A and pass it to the selvage.

Lift 34, pass B all across. An (A,A,B) colour sequence is being used in order that oblique colour stripes will show up the changes of twill direction.

Lift 14, pass A to the first marker and take it out of the shed.

Change the shed to 23.

Enter A and pass it to the second marker and again take it out.

Change the shed to 14.

Enter A and pass it to the selvage.

Repeat, always keeping the (A,A,B) sequence going.

#### Note

— The weft always has to pass between the two raised ends of a pair, either when leaving or entering the shed at a marker. This is to avoid a float over or under four ends.

By changing the positions of the markers the central area can increase or decrease in size or shift sideways.

Plate 26 (p. 59) shows this technique with a change to (A,B,B) colour sequence at the centre. Compare with Plate 57 (p. 122) in which the same effect is produced by shaft-switching.

Naturally the above method can be applied to other colour sequences in the weft; whatever small pattern is produced will be mirror-imaged in the central area.

### 2/2 Twill 'Woven on Opposites'

In this weave, each of the four normal lifts for 2/2 twill is immediately followed by the opposite lift. As Fig. 48 shows, 12 is followed by 34, then 23 is followed by 14, and so on, giving a sequence of eight lifts. Two colours used alternately, as in Fig. 48(a), will give oblique stripes of equal width; they follow the direction of the structural twill and are indeed emphasized by it. The two wefts have been shown in the weave plan and can be seen to lie on a diagonal moving up to the left, in the direction of the arrow.

Naturally the stripes can be made to lie on the other diagonal by reading the lifts in the reverse order. But almost the same effect can be obtained simply by changing the colour sequence from (A,B,A,B) to (A,B,B,A), the lifts remaining unaltered; see Fig. 48(b). So here the colour stripe is running counter to the structural twill and is in fact visually not as perfect. It does mean, however, that by applying the principle of Crossed Wefts in Parallel Motion to this twill, areas striped

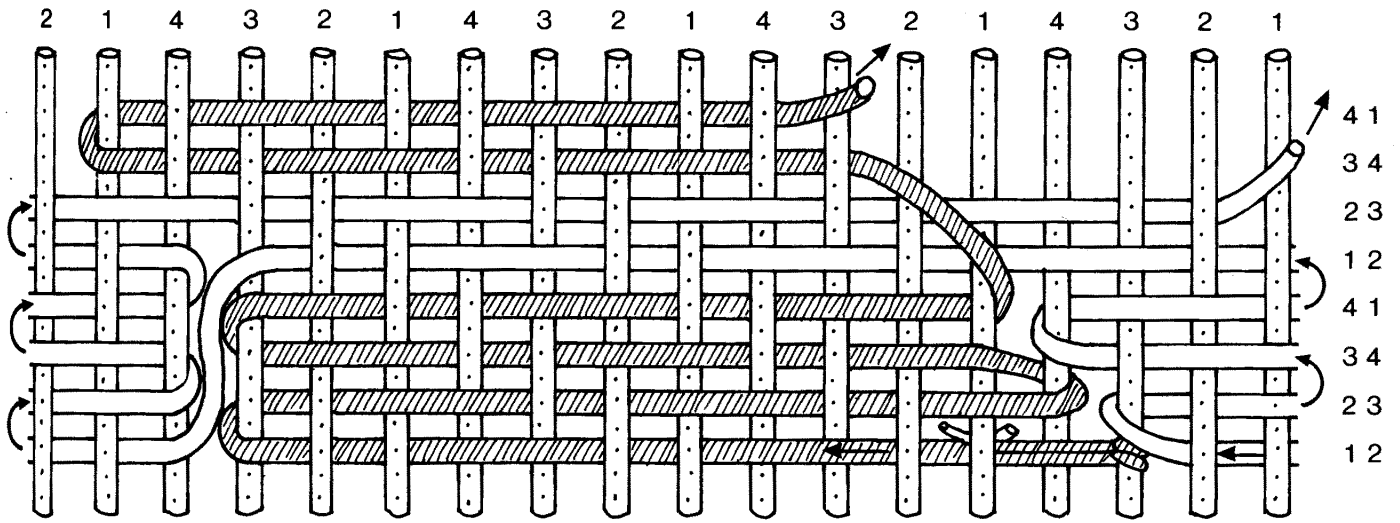

Fig.46

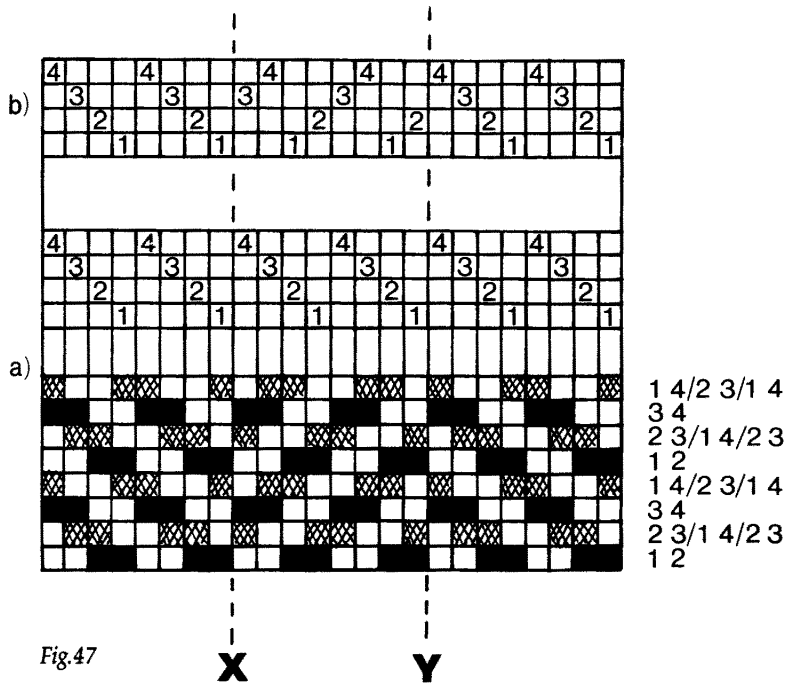

Fig.47

**X** **Y**

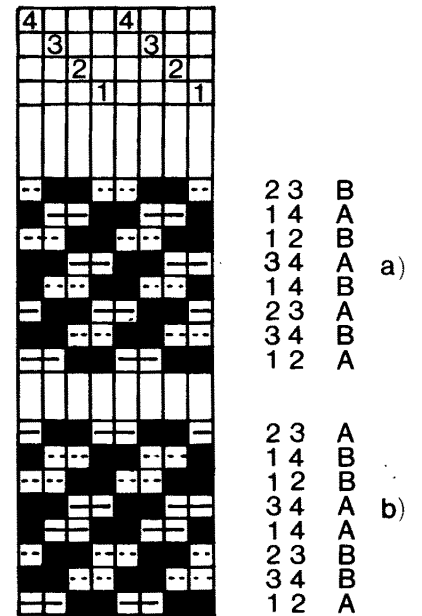

Fig.48

Plate 27 (see pp. 60,64)



Plate 28 (see p. 64)



Plate 29 (see p. 64)

on the two diagonals can be woven side by side; see Plate 27 (p. 62). It is worked as follows (see Fig. 49):

Lift 12, throw A from right to left.

Lift 34, throw B from right to left.

Lift 23, throw A left to right only part-way, say one-third, across the warp then bring it out of the shed.

Lift 14, throw B part-way, taking it out of the shed two ends short of A's exit point. This is easy because of the way the sheds are working.

Lift 23 again, enter B into the shed, making sure it floats over four ends and bring it out another third of the way across.

Lift 14, enter A into the shed so that moving vertically it ties down the centre of the above float. Bring it out two ends short of B's exit point.

Lift 23, enter A into the shed, once more making a float over four ends, and take it all the way to the right selvage.

Lift 14, enter B into the shed so that it ties down the above float and pass it to the right selvage.

Lift 34, throw A to left.

Lift 12, throw B to left.

Lift 14 for A and 23 for B and work another two crossing picks exactly as those bracketed above, except that the points of entering and leaving the shed are of necessity moved two ends to the left or right.

Repeating these eight picks (all shown in Fig. 49) gives a rectangular central area whose borders are pleasantly different, because at the left crossing point it is weft B which has a long float and at the right it is weft A; see Plate 27 (p. 62).

It will be found that of the two wefts being thrown alternately one always catches the selvage thread and one always misses it but catches the next thread in. If the latter weft is allowed to miss the selvage, but the former is wrapped round the selvage thread before throwing, a very convincing one-colour selvage is produced. Unlike the similar Grierson edge, used for pick-and-pick in plain weave, there is no 'jump' forward at the back, so both sides of the rug are equally usable.

In Fig. 50, where there is an even number of working ends, it is weft A which misses the selvage and B which wraps at both edges. B wraps upwards when it is about to enter the shed under the selvage (see first wrap on the right); and wraps downwards when it is to enter the shed over the selvage (see first wrap on the left). Failure to follow this simple rule will produce a float over three ends. Occasionally a double wrap may be necessary to keep the fell level. Plate 28 (p. 62) shows this selvage in use with a reversal of colours where the diagonals change direction; compare with Plate 27 (p. 62) where both wefts have been caught round a floating selvage.

If the warp has an odd number of working ends, it is A which wraps (and B which misses the selvage) at one side, and B which wraps (and A which misses the selvage) at the other side. See the blue-and-white selvages in Plate 59 (p. 126).

Using Crossed Wefts in Contrary Motion with this weave gives a central area of oblique stripes with vertically aligned spots on either side. With the two wefts at opposite selvages, start with the *second* pick in the lifting sequence and make the crossings as in Fig. 42 (p. 56). See Plate 29 (p. 63).

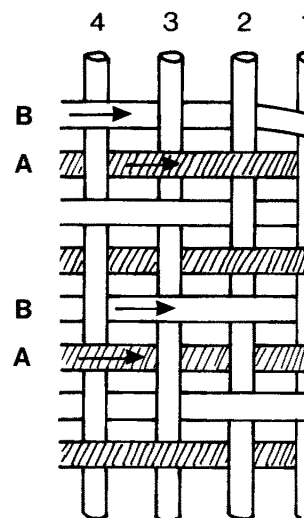
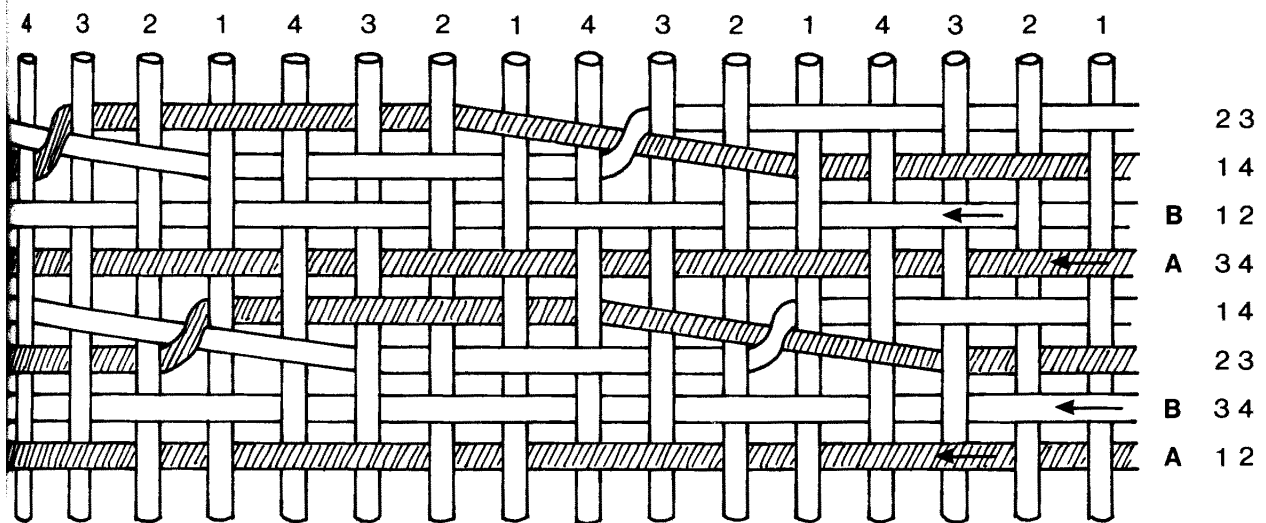
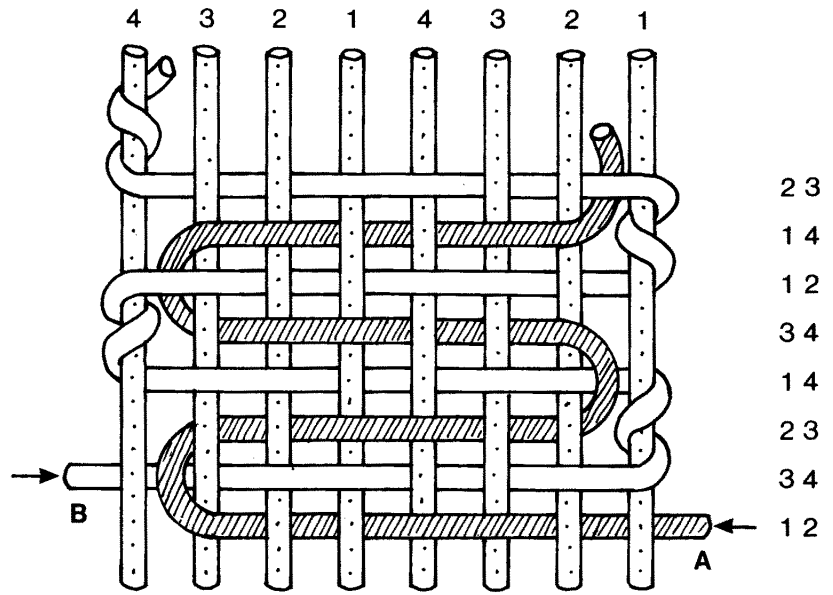

Fig.49



Fig.50



## Block Weaves



Plate 30 (see p. 68)

Plate 31 (see p. 68)



Plate 32 (see p. 68)

## Three-shaft Block Weave

Four shafts are usually thought the minimum necessary for a weft-face block weave, but an interesting one can be woven on only three shafts. It uses the three possible pointed drafts, i.e. (1,2,3,2), (2,3,1,3) and (3,1,2,1). Each repeats on four ends, but if a number of repeats *plus* one end are always threaded, the three drafts will join perfectly in any sequence. *Fig. 51* shows two repeats of each draft making blocks labelled I, II and III; the linking end is circled. Of course, this I, II, III sequence is only one of several possibilities; or any two of the blocks could be used by themselves.

The plan of one possible weave is shown in *Fig. 51* and it includes all the six lifts possible with three shafts. It will be seen that each of the six picks takes a plain weave course across one of the blocks but an over 3, under 1 (or under 3, over 1) course across the other two blocks. Thus pick 1 weaves plain in Block III, but passes over 3, under 1 in Blocks I and II; pick 2 weaves plain in Block II, and passes under 3, over 1 in Blocks I and III.

When these picks are beaten in, it will be found that where the weft is weaving plain it is completely hidden by the 3-span weft floats on the front and back. The result is that only picks 1, 3 and 5 show on the front of the rug; these are marked on the diagram. There is a similar arrangement of visible colours on the back. So the colouring of the blocks is more complex than in other block weaves, any colour inevitably showing in two blocks.

The following are some of the possible colour sequences applicable to this weave.

1. (A,B,A,B) gives a rug with solid colour A on the front and B on the back.
2. (A,A,B,B) gives waving cross-stripes which do not tally exactly at the junctions *between* blocks.
3. (A,A,A,A,B,B); (B,B,A,A,A,A); (A,A,B,B,A,A). Each of these six-pick sequences, if repeated, will give one block of solid A colour, the other two blocks being striped vertically with A and B. If they are used in the given order, the block of solid A will move diagonally. If the blocks are in a I,II,III,II,I sequence, the solid A blocks will appear as a diamond, as seen in Plate 30 (p. 66), where each sequence was repeated ten times.
4. If one of the above sequences is taken and the colours counter-changed periodically, so several repeats of (B,B,A,A,A,A) would be followed by several of (A,A,B,B,B,B), solid areas of A and of B will lie above each other, flanked by striped areas, as in Plate 31 (p. 67).
5. (A,A,B,B,C,C) gives three blocks each striped with a different pair of colours.

A quite different approach is to weave this as a three-shaft Krokbragd, lifting it (12,23,13) and using a varying sequence of two or three weft colours. Small-scale patterns typical of Krokbragd will appear but will be different in each of the three blocks, as Plate 32 (p. 67) shows. If, while designing, a

block is considered, what turns up in the other two can be pleasantly surprising.

As with normal Krokbragd, the back of the rug is quite different. It has simpler patterning which looks as if it were woven in plain weave.

A good warp setting is five working ends per inch, with a weft of 2-ply carpet wool used two- or three-fold. The selvage of the three-colour section at the top of Plate 32 (p. 67) was worked as shown in *Fig. 41* (p. 53).

## Three-end Block Weave

In this the simplest of the four-shaft block weaves, the three-end threading units are (2,3,1) repeated ad lib, and (2,4,1) repeated ad lib. In some predetermined order, these are disposed across the width of the warp. *Fig. 52* shows a small example with only six units, threaded (2,3,1) × 2, (2,4,1) × 2, (2,3,1) × 2, and *Fig. 53* shows the corresponding thread diagram.

The shafts are lifted in the sequence (13,14,23,24) with an (A,B,A,B) colour sequence. This causes each weft partly to weave over 2, under 1, and so show on the front, and partly to weave under 2, over 1, and so show on the back of the rug. Taking the first pick as an example, A (dark) passes under 2, over 1 in the two outer blocks threaded (2,3,1), so will appear on the back. But in the central block threaded (2,4,1), it passes over 2, under 1 and so will appear on the front.

Pick 2, white, does exactly the opposite, appearing on the front in the outer blocks and on the back in the centre. When beaten these two picks slide over each other in such a way that the white is the only colour visible in the outer blocks, and the dark in the centre; i.e. the parts heavily outlined slide over and cover the parts marked with crosses.

Picks 3 and 4 are similar but with their floats shifted one end to right or left and when beaten they slide over each other in the same way.

When this sequence of four picks is repeated several times, blocks will begin to appear as at the bottom of *Fig. 53*. Thus the position of the blocks depends entirely on how the warp is threaded; once this is done, the blocks are fixed. See Plates 33 and 34 (pp. 70–1) which show the two sides of a sample.

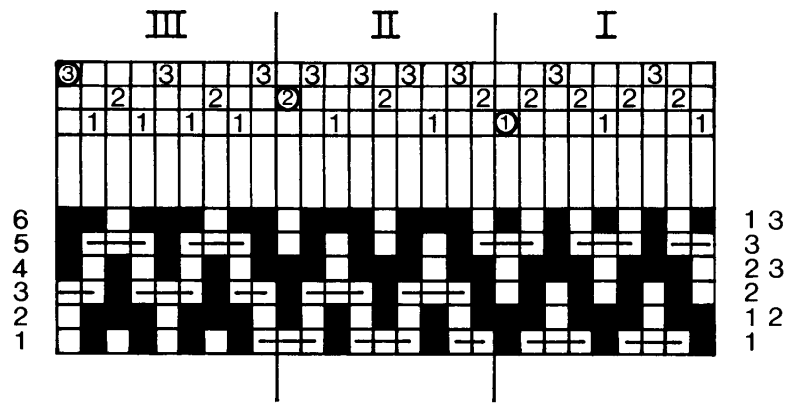

Fig.51

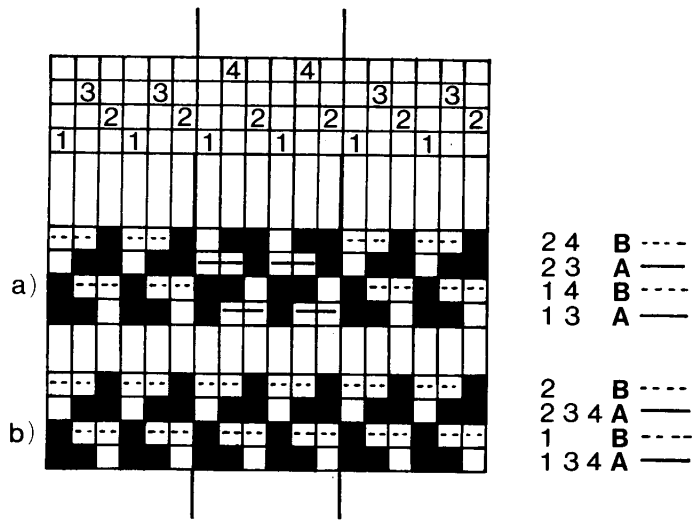

Fig.52

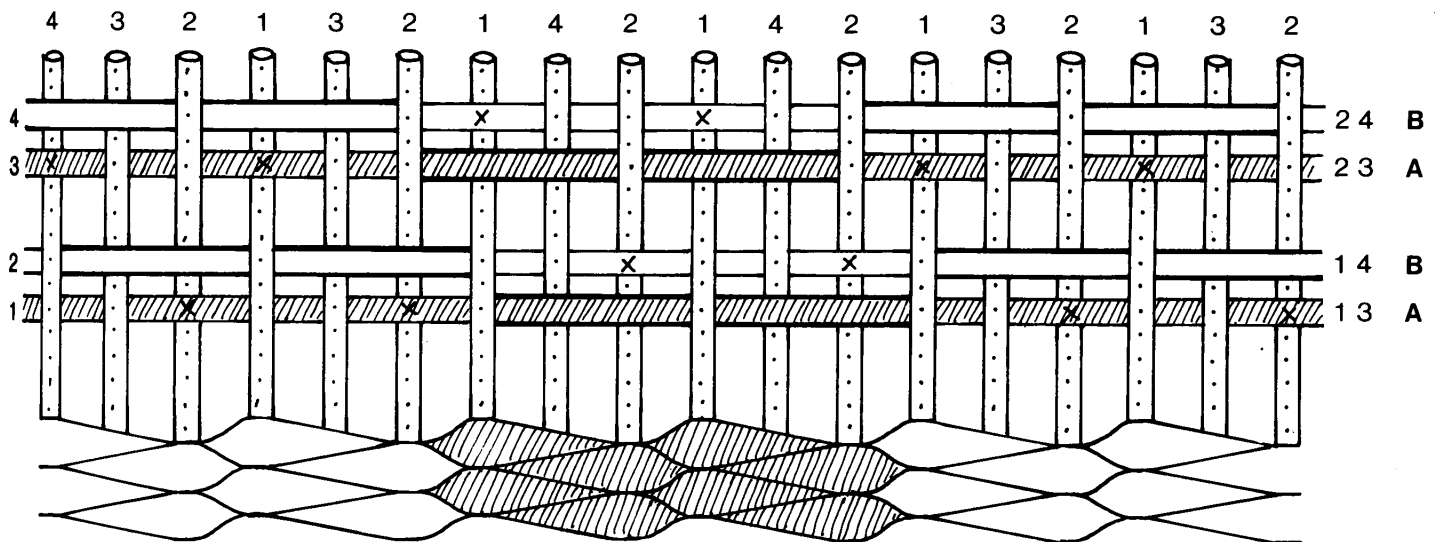

Fig.53

FRONT



Plate 33 (see pp. 72-3)

BACK



Plate 34 (see pp. 72-3)

## Practical Details

### Threading Warp

A setting of 4 working epi is ideal. So if the warp consists of 6 epi on the beam, it has to be threaded alternately single, double in the heddles (starting and finishing with a triple selvage thread), and sleyed similarly. Using the threading described, the selvages catch perfectly when two shuttles are thrown alternately. But to accommodate all variations of the technique, it is best to have the outermost thread at each side as an adjustable floating selvage; see Fig. 54(a).

Leave an empty heddle on shaft 4 beside every filled heddle on shaft 3, and an empty heddle on 3 beside every filled heddle on 4, as shown. This is done for two reasons: first, so that with a long warp, the position of the blocks can easily be changed after each rug is woven and cut off; second, so that the warp set-up is ready for later conversion to shaft-switching if required.

The threading unit therefore needs four heddles (one on each shaft), of which three carry warp ends and one is left empty. All these details are seen in Fig. 54(a) which shows the first two, right-hand, units and the final unit on the left of a rug warp.

An 8 dents/inch reed with thick wires works well and is sleyed as shown in Fig. 54(b).

### Weft

A 2-ply carpet wool used three-fold – or yarn of similar thickness – is suitable.

### Heading

As no plain weave is possible, weave the heading with a lifting sequence of (13,24,14,23). This uses the two pairs of opposite lifts and opens the warp out satisfactorily. One shuttle carrying a very heavy yarn can be used and it will catch at both selvages, due to the alternation of 1 and 2 in the lifts.

### Starting to Weave

One or two rows of weft twining is desirable before the rug proper begins, as it makes a better structure against which to work a rug finish than the block weave itself.

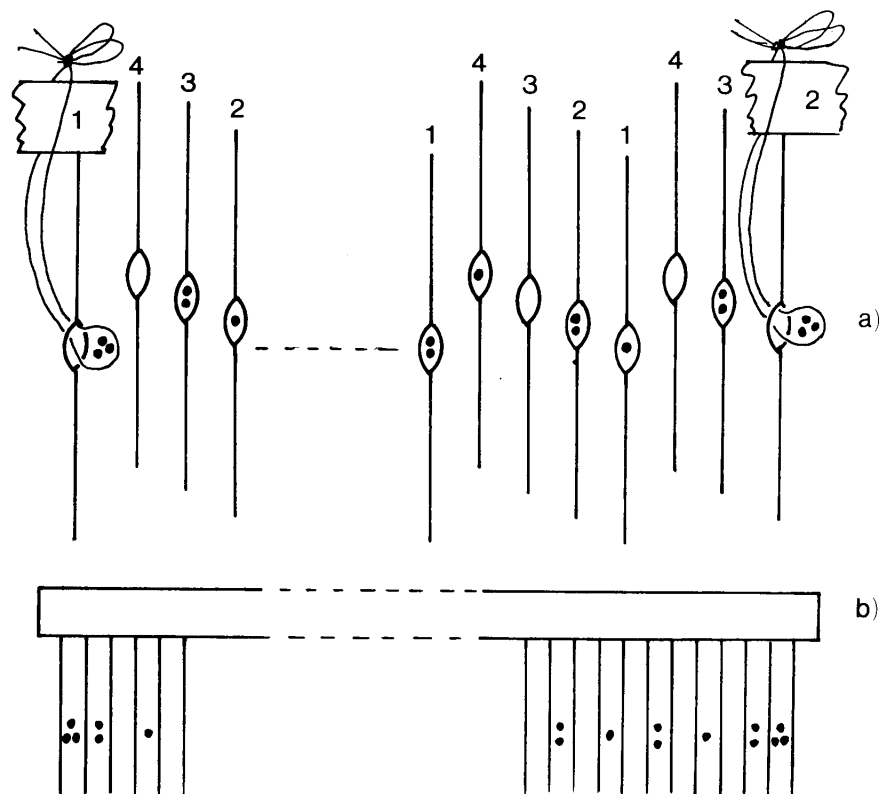

Fig. 54



The two wefts, A and B, can either both start from the same side, or A, say, from the right and B from the left. There is always a tendency for a weft, which should be confined to the back, to show slightly on the front and vice versa; X in Fig. 53 marks the points where this can occur, an effect obviously more apparent if A and B differ greatly in depth or hue. Now if A and B are started from opposite sides and each pick is beaten in separately, these little spots of colour will be seen. But if they are started from the same side, they can easily be waved together and then beaten together. The spots will then be eliminated because by this means the wefts have a better chance of sliding one behind the other.

Whichever shuttle is weaving the colour showing on the outermost block should always lie in front of the other shuttle during weaving. This ensures that the wefts take the nearest route as they enter each shed.

### Weaving Blocks

The lifts to make the blocks appear are (13,14,23,24) with the two wefts alternating.

There are two ways of counter-changing the colours in the blocks.

1. Change the colour sequence to (B,A,B,A), but keep the lifting sequence unchanged. So it becomes 13,B; 14,A; 23,B; 24,A.
2. Change the lifting sequence to (14,13,24,23), but keep the colour sequence unchanged. So it becomes 14,A; 13,B; 24,A; 23,B.

### Weaving a Solid Colour all Across

If a solid colour all across is wanted, the shafts can be lifted as for the blocks but using two shuttles alternately, *both* of which carry the same colour. Two shuttles are used to ensure that the weft catches both selvages. The back and front of the rug will then show one colour all across.

Alternatively, the two-colour weft sequence (A,B,A,B) can be maintained, but the lifts altered to (134,1,234,2), as shown in Fig. 52(b). The rug will then have colour B all across on the front and colour A on the back. See the areas between the blocks in Plates 33 and 34 (pp. 70–1).

#### *Note*

— *Before moving from one of these sequences to the other, always complete the four lifts.*

FRONT

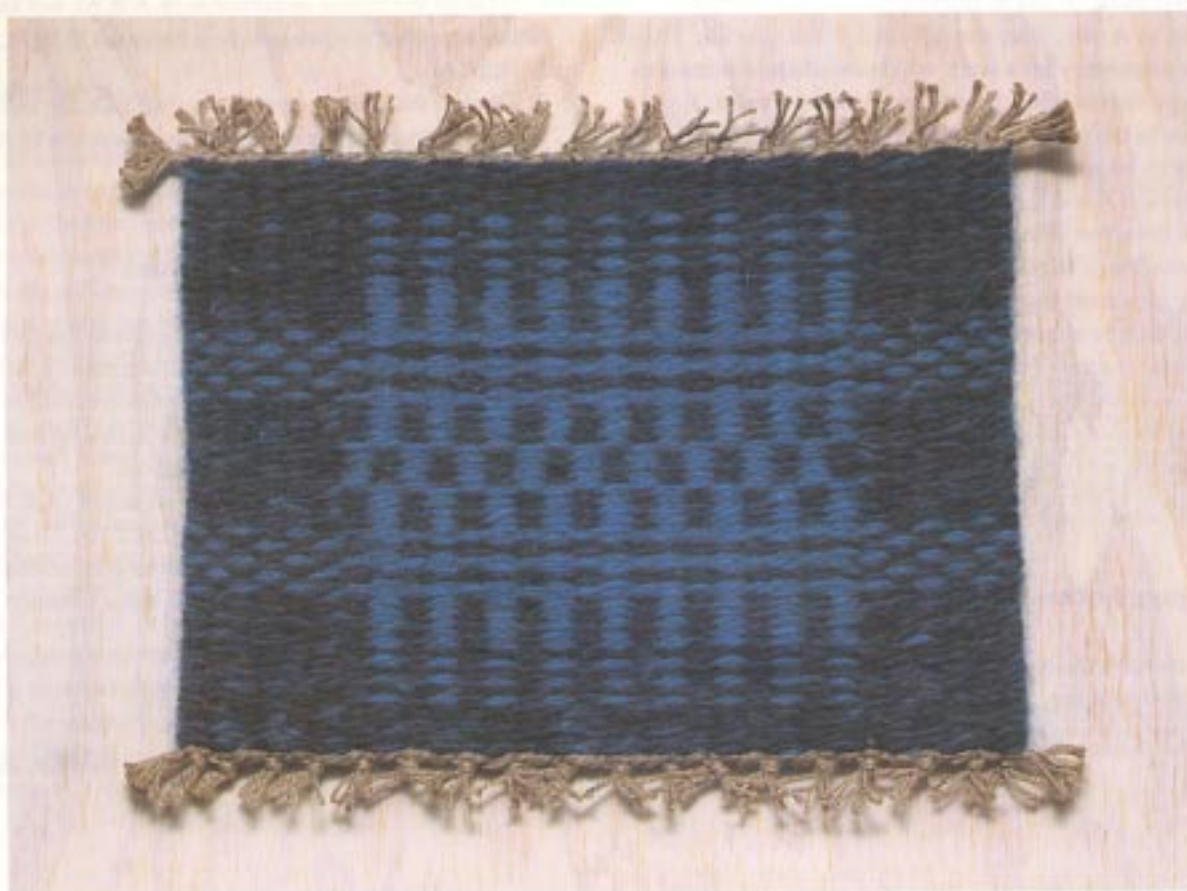

BACK

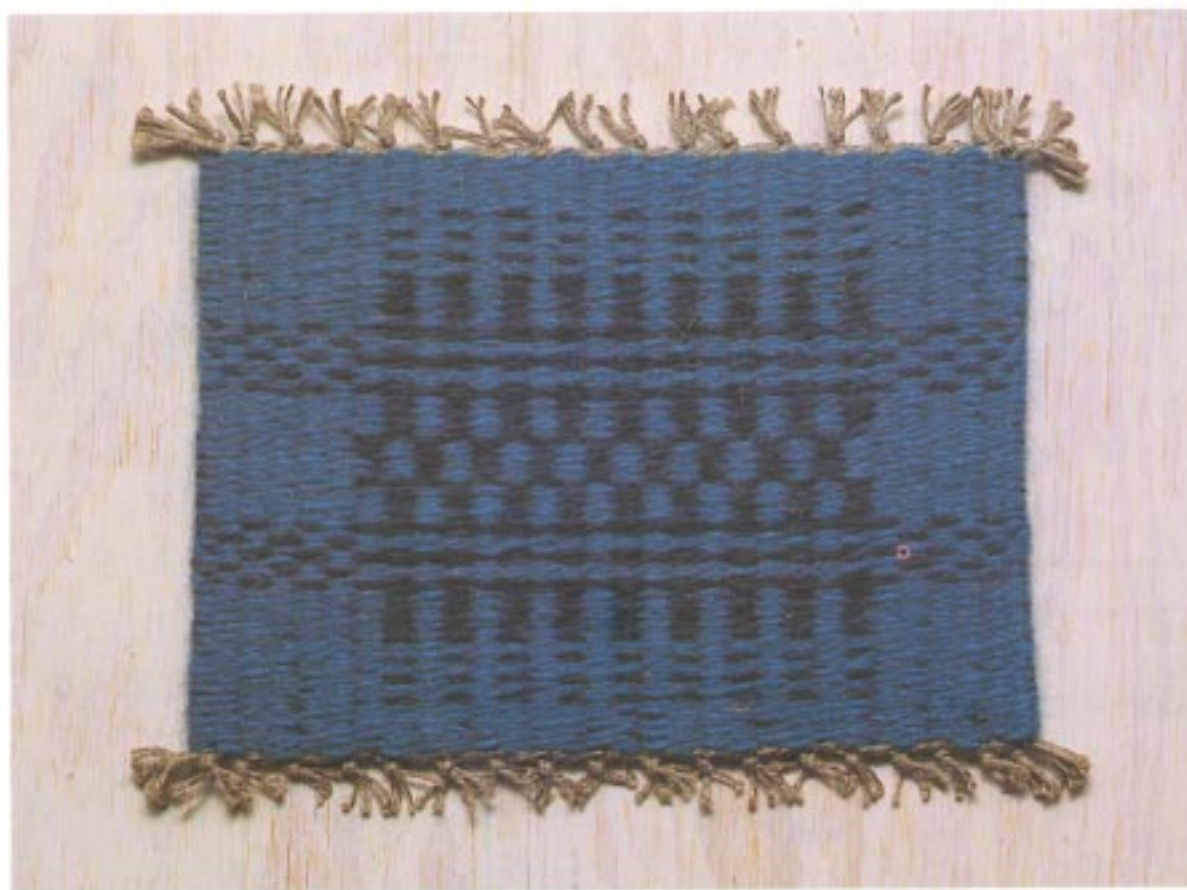

## Weaving Stripes and Spots

Much variety can be introduced into the blocks by turning them from areas of solid colour into areas of spots and weft- and warpway stripes. See Plates 35 and 36 (left).

Fig. 55 is a table of the two-colour variations. These are shown in diagrammatic form down the centre of the table; to the left of the midline they are in the blocks threaded on (2,4,1), to the right of the midline in the blocks threaded on (2,3,1). All the variations can be produced in two quite different ways.

1. Constant Colour Method. The colour sequence (A,B,A,B) remains unaltered but the lifts are changed. These lifts are shown on the left of each variation.
2. Constant Lift Method. The lifts (13,14,23,24) remain unaltered, but the colour sequences are changed. These are shown on the right of each variation.

Usually the first way is the easier to weave as there are never the selvage problems encountered in the second method. But it does involve the use of eight different lifts (all those shown in Fig. 52[a] and [b] in various combinations), instead of only four.

Constant colours (A, B, A, B)	Blocks on (2,4,1)	Blocks on (2,3,1)	Constant lifts (13, 14, 23, 24)
(13, 14, 23, 24, 134, 1, 234, 2)			(A B A B B B B B) a)
(13, 14, 23, 24, 1, 134, 2, 234)			(A B A B A A A A) b)
(13, 14, 234, 2)			(A B B B) c)
(134, 1, 23, 24)			(B B A B) d)
(13, 14, 2, 234)			(A A A B) e)
(1, 134, 23, 24)			(A B A A) f)
(13, 14, 234, 2, 134, 1, 234, 2)			(A B B B B B B B) g)
(13, 14, 2, 234, 1, 134, 2, 234)			(A B A A A A A A) h)
(13, 14, 234, 2, 134, 1, 23, 24, 134, 1, 234, 2)			(A B B B B B) i)
(13, 14, 2, 234, 1, 134, 23, 24, 1, 134, 2, 234)			(A B A A A A) j)

Fig.55

### Weftway stripes

See Fig. 55(a) and (b). The instructions given in the table will give the narrowest possible stripes; these can be widened by repeating the first or second half of the sequence as often as wished.

### Warpway stripes

See Fig. 55(c) to (f). These are produced by making the two wefts surface alternately in the chosen block. They beat down to make narrow stripes in the warp direction (see top of Fig. 56), comparable to pick-and-pick stripes in plain weave. The stripes can be made to shift one end sideways, as shown; compare (c) with (d), and (e) with (f). This small manoeuvre is useful in a rug design as it helps disguise the fact that the stripes can never be centred exactly on a block.

### Spots

See Fig. 55 (g) to (j). Spots can either be aligned in vertical columns, see (g) and (h), or staggered, see (i) and (j), also Fig. 56 at bottom. They are produced by alternating one of the sequences for warpway stripes with those for solid colour all across. In this way the two wefts surfacing in a block will either be in a (A,B,B,B) or (A,B,B) sequence.

When weaving stripes and spots using the Constant Colour method, the back is an exact reverse of the front; wherever A shows on the front B shows in the identical place on the back; compare Plates 35 and 36 (p. 74). Using the Constant Lift method, it is the blocks themselves which are reversed on the back, not the individual colours; compare Plates 38 and 39 (p. 79).

To make warpway stripes all across the rug, lift (134,1, 234,2) with a (B,A,A,B) or a (A,B,B,A) colour sequence.

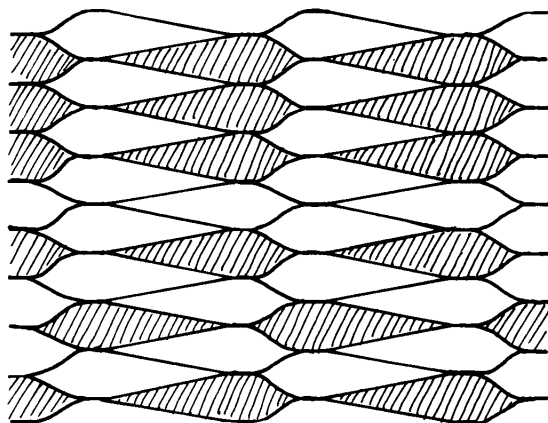

Fig.56

### Combinations

Obviously these features can be combined; for instance there could be spots in the blocks threaded (2,3,1) and cross-stripes in the blocks threaded (2,4,1). To work out such a combination, a basic fact has to be understood.

A weft inserted when  $\underline{13}$  or  $\underline{23}$  is lifted appears in the blocks threaded (2,4,1); and a weft inserted when  $\underline{14}$  or  $\underline{24}$  is lifted appears in the blocks threaded (2,3,1).

Using the Constant Lift method, write out the lifts several times. Then over the  $\underline{13}$ s and  $\underline{23}$ s (because the stripes are wanted in the 2,4,1 blocks) write a colour sequence which will give stripes, e.g. A,A,A,B,B,B. Then under the  $\underline{14}$ s and  $\underline{24}$ s write a sequence which will give spots, e.g. A,B,B for staggered spots. So it now looks like this:

A	A	A	B	B	B
13, 14,	23, 24,	13, 14,	23, 24,	13, 14,	23, 24,
A	B	B	A	B	B

Combining these two into (A,A,A,B,A,B,A,B,A,B,B,B) and weaving this unlikely-looking colour sequence will give the desired result. There will of course be selvage problems, necessitating a floating selvage. Though woven by the Constant Colour method, Plate 35 (p. 74) shows in two places a comparable combination of spots and stripes as just described.

By the same reasoning it can be worked out that in order to weave the type of interlacing pattern seen in Fig. 57, the colour sequences are:

(A,A,B,A) × 2, (A,B,B,B) × 2, for one step in the design  
 and (A,A,A,B) × 2, (B,A,B,B) × 2 for the next step.  
 See Plate 37 (p. 78) for the woven result.

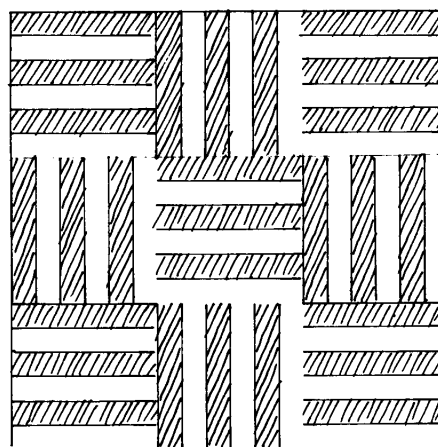
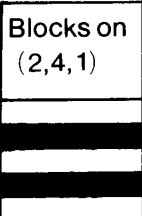
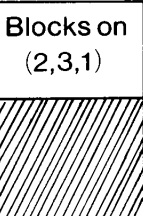

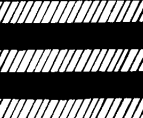



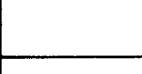

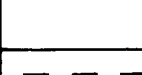





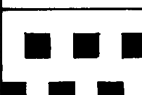





Fig.57

## Using Three Colours

The introduction of a third weft colour means that a block can show stripes or spots in two colours and be flanked by blocks of a third colour. These variations are best worked in the Constant Lift method, all the effects coming from the different sequences of the three colours. Fig. 58 presents a table of some of the possibilities, most of which are seen in Plate 38 (p. 79).

The cross-stripes in (a) and (b) present no difficulties, but the warpway stripes, (c) to (f), all give selvage problems. The weaving of (c) will be described in detail to illustrate how these problems can be dealt with.

Blocks on (2,4,1)	Blocks on (2,3,1)	Constant Lifts (13,14,23,24)	
		(A B A B C B C B)	a)
		(A B A B A C A C)	b)
		(A B C B)	c)
		(C B A B)	d)
		(A B A C)	e)
		(A C A B)	f)
		(A B A B A B C B)	g)
		(A B A B A B A C)	h)
		(A B A B C B)	i)
		(A B A B A C)	j)

 = A

 = B

 = C

Fig.58



Plate 37 (see p. 76)

FRONT



Plate 38 (see pp. 76,77,80)



Plate 39 (see p. 76)

BACK

Start with weft B at the left selvage, and wefts A and C both at the right; see Fig. 59 (for the sake of clarity, B is not shown. It weaves normally throughout).

Lift 13, pass A *under* the selvage end (which is down) and up into the shed, forming a float under three ends.

Lift 14, throw B to the right.

Lift 23, bring C *up* between the two outermost ends (on shafts 2 and 3), thus tying down the above float, and throw it to the left.

Lift 24, throw B to the left.

All three wefts are now at the left selvage.

Lift 13, pass A *over* the selvage end and down into the shed.

Lift 14, throw B to the right.

Lift 23, pass C *down* between the two outermost ends and then into the shed. It forms a float under three ends which is already tied down by the last pick of A.

Lift 24, throw B to the left.

The wefts are back at their starting positions and the above eight picks can be repeated. Fig. 59 shows how A and C behave at the selvage; they cross in a way similar to that in the pick-and-pick selvage using the Navajo Method 2.

#### Note

— With all the possibilities shown in Fig. 58, a block can display any of the small-scale two-colour patterns obtained with plain weave, but here they are in a specific area surrounded by a third colour, as Plate 38 (p. 79) shows.

#### Combinations

Applying the principle described for two colours, it is possible to work out a colour sequence which will give, say, aligned spots in one block (with an A,A,A,B sequence) with cross-stripes in the alternate block (with a C,C,B,B sequence). This gives the following: (A,C,A,C,A,B,B,B). The idea can of course be extended to include four colours, so each block is completely different in both colouring and patterning.

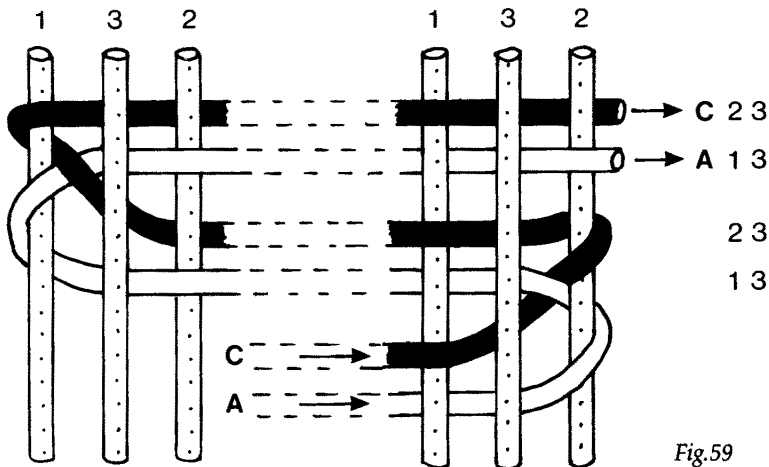

Fig.59

#### Other Ways of Weaving Three-end Block Weave

1. The order of the four lifts in either sequence in Fig. 52 can be altered so that for a solid colour it becomes (134,234,2,1), and for the blocks (13,23,24,14). In both cases the colour sequence must also change to (A,A,B,B). The appearance is slightly different, with the underside weft tending to show more on the front. This sequence is used to advantage in the pick-up version of this block weave.
2. Lifting as for the heading, i.e. (13,24,14,23), with a colour sequence of (A,B,A,B,A,B,A) gives small oblique lines in the blocks threaded on (2,3,1) and zigzag cross-stripes in the other blocks. The blocks can be counter-changed by lifting (24,13,23,14) or (14,23,13,24), in both cases using the above colour sequence. The latter lifts were used in Plate 40 (p. 82) and this kept the oblique lines running on the same diagonal in all the blocks.
3. Lifting as for a 2/2 twill, (12,23,34,14), with a colour sequence of (A,A,B,B) gives solid colour in the blocks on (2,3,1) and vertical stripes in the other blocks. So it is similar to Fig. 55 (e) and (f). The blocks are counter-changed with an (A,B,B,A) sequence; whereas a (A,B,A,B) sequence gives vertical stripes all across.

#### Varying the Appearance of the Blocks

1. Varying the blend of colours. As the weft is usually a yarn used two- or three-fold, there is every opportunity for winding several colours together on one or both shuttles and for changing these colours subtly or suddenly in the course of weaving a block, as seen in Plate 33 (p. 70).

