

per yard. After it has passed through the slubber, it is called roving and the weight is based upon the number of hanks, of 840 yards each, there are in one pound.

The English table of weights is a combination of avoirdupois and troy weights and enables a very fine adjustment to be made.

TABLE OF WEIGHT.

24 grains	=	1 pennyweight (dwt.)
437.5 "	=	18 " + $5\frac{1}{2}$ grains = 1 ounce.
7000 "	=	291 " + 16 grains = 1 pound.

TABLE OF MEASURE.

1.5 yards	=	1 thread.
120 yards	=	80 threads = 1 skein.
840 yards	=	560 threads = 7 skeins = 1 hank.

If we measure 840 yards of roving and find that it weighs one pound, it is called one hank and weighs, per yard, 8.33 grains.

$$7,000 \div 840 = 8.33$$

If there are 1680 yards in one pound, it is called two hank, and weighs, per yard, just half as much as one hank, or 4.16 grains.

$$7,000 \div 1680 = 4.16$$

If 420 yards weigh one pound, it is half hank and weighs 16.66 grains per yard.

Number 1 roving, or one hank, and number 1 yarn weigh the same per yard, but as the roving is twisted so much less than the yarn, it appears to be much heavier.

For convenience and on account of the extreme delicacy of roving, it is customary, in actual practice, to measure twelve yards to ascertain the weight. The reason for taking just this length is as follows: There are 840 yards in a hank and twelve yards is $\frac{1}{70}$ of this amount and if we divide twelve yards by $\frac{1}{70}$ of a pound (100 grains), we get the same result as if we should weigh the whole hank.

12 yards	=	$\frac{1}{70}$ of a hank or 840 yards.
100 grains	=	$\frac{1}{70}$ of a pound or 7,000 grains.

The following table gives the weight and standard twist for roving from .25 hank to 20.00 hank.

ROVING TABLE.

Hank Roving.	Grains per Yard.	Twist per Inch.	Hank Roving.	Grains per Yard.	Twist per Inch.
.25	33.33	.60	2.00	4.16	1.70
.30	27.77	.65	2.25	3.70	1.80
.35	23.80	.70	2.50	3.33	1.90
.40	20.83	.75	2.75	3.30	1.99
.45	18.51	.80	3.00	2.78	2.08
.50	16.66	.84	3.50	2.38	2.24
.55	15.15	.88	4.00	2.08	1.40
.60	13.88	.92	4.50	1.85	2.55
.65	12.82	.95	5.00	1.67	2.68
.70	11.90	1.00	6.00	1.39	2.92
.75	11.11	1.04	7.00	1.19	3.18
.80	10.42	1.07	8.00	1.04	3.40
.85	9.80	1.11	9.00	.92	3.60
.90	9.26	1.14	10.00	.83	3.79
.95	8.77	1.17	11.00	.76	3.97
1.00	8.33	1.20	12.00	.69	4.15
1.10	7.58	1.26	13.00	.64	4.33
1.20	6.94	1.31	14.00	.59	4.49
1.30	6.41	1.37	15.00	.55	4.65
1.40	5.95	1.42	16.00	.52	4.80
1.50	5.55	1.47	17.00	.49	4.95
1.60	5.21	1.52	18.00	.46	5.09
1.70	4.90	1.56	19.00	.43	5.23
1.80	4.63	1.61	20.00	.42	5.37
1.90	4.38	1.65			

The Slubber receives the cans of sliver at the back, from the last drawing frame and it is put through the machine and wound upon bobbins. These bobbins are then placed in the creel of the intermediate frame and the roving is put through the same process and delivered to the creel of the fine frame, where the operations which occur on the other machines are repeated.

A section of a fine frame is given in Fig. 161. The bobbins, A, are placed in the creel, two ends for each spindle. The roving passes around the rod, B, and through the trumpets, or guides, C, and is drawn between the draft rolls, D, E and F. From the front roll it passes to the nose of the flyer, G, through the hole, H, and down one leg of the flyer and through the eye of the presser, K, and is finally wound upon the bobbin, L.

The flyers, of which there are two rows, fit snugly in the top of the spindle, J, and revolve with it. This causes the roving to be twisted, which gives it sufficient strength to enable it to be wound upon the bobbins.

The spindles are stationary so far as any vertical movement is concerned. They rest in steps, M, which are carried by the step rail, K¹.

The bobbins, which are driven separately, from the spindles, are carried by the bobbin, or bolster rail, N, which is made to traverse

up and down so that the layers of roving shall be wound evenly.

A drawing of the spindles, bobbins and flyers is shown in Fig. 162. The upper part of the spindle is supported by the bolster, P,

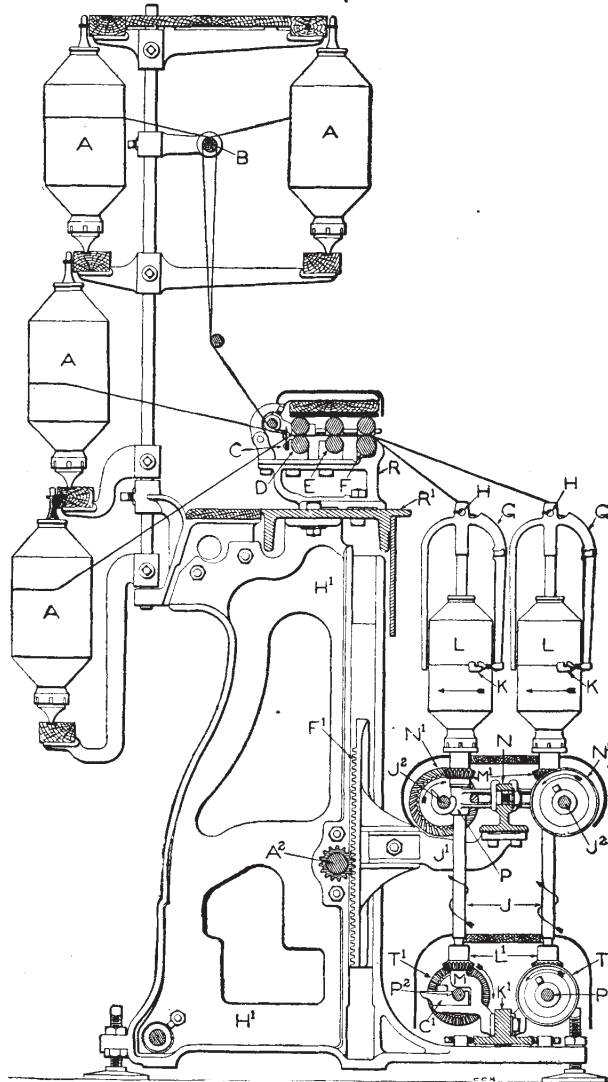

Fig. 161. Sectional Elevation of Fine Fly Frame.

which is fastened to the bobbin rail and the bobbin, which seems to be upon the spindle, is simply a loose fit around the bolster.

The spindles are driven from the spindle shaft, P², by the

bevel gears, L^1 and T^1 , and the bobbins are driven from the bobbin shaft, J^2 , by the bevel gears, M^1 and N^1 . The gear, M^1 , revolves upon the bolster and the bobbin, which is slotted on the bottom, is driven from the gear by a pin which fits into one of the slots. The bobbin revolves between the arms of the flyer and in the same direction as the flyer, but to wind the roving, it must run faster or slower than the flyer.

Flyer Lead and Bobbin Lead. The front roll delivers the roving at a constant speed which accords to the hank being spun, and the roving must be wound upon the bobbin at the same speed by which it is delivered. There are two ways by which this is accomplished: "The Flyer Lead" and "The Bobbin Lead". The first mentioned is the older method and is used upon the "Speeder", a machine which corresponds to the fly frame and may be found in operation in some mills at the present time.

With the "Flyer Lead", the flyer is run at a constant speed, which is greater than that of the bobbin and the roving is wrapped upon the surface of the bobbin by the excessive speed of the flyer. As the bobbin increases in diameter, its speed must be accelerated so that it shall wind the same length that the front roll delivers.

With the "Bobbin Lead" which is used upon the fly frame, the flyer is run at a constant speed but less than that of the bobbin. The roving is drawn onto the surface of the bobbin by the excess of its speed over that of the flyer, and as the bobbin increases in diameter, its speed must be decreased gradually.

It would seem that, with the "flyer lead," to increase the speed of the bobbin would cause a greater length of roving to be wound

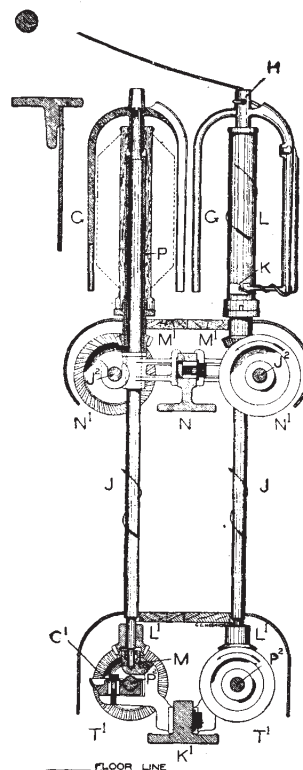

Fig. 162.
Enlarged View of Spindles.

and, as this is puzzling to many, it will bear further explanation.

We will call the speed of the flyer 200 R.P.M. and the speed of the empty bobbin, which is one inch in diameter, 100 R.P.M. As the circumference of a one inch bobbin is 3.14+ inches, each revolution that the flyer makes, more than the bobbin, will wind 3.14+ inches of roving, and while the flyer is making two hundred revolutions, 314+ inches of roving will be wound upon the bobbin.

When the bobbin is two inches in diameter, its circumference is 6.28+ inches, and if the flyer and the bobbin continue to run at

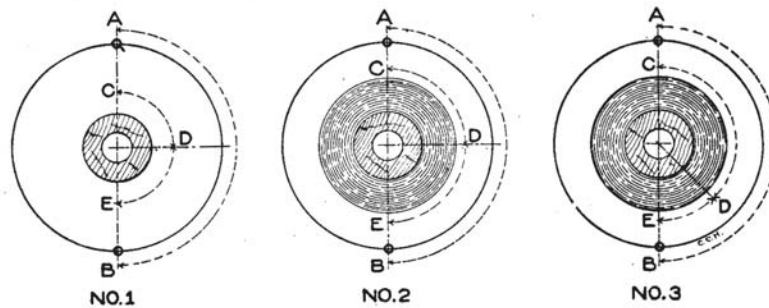

Fig. 163. Diagram Illustrating Flyer Lead.

the same relative speed, two hundred revolutions of the flyer will cause 628 inches of roving to be wound.

The diagrams, shown in Fig. 163, will help to make this plain. Number 1 shows the flyer as having made one-half of a revolution, from A to B, and the empty bobbin, which we will call one inch in diameter, one-quarter of a revolution, from C to D. The length of roving wound will be equal to the distance around the barrel of the bobbin from D to E, which is one-quarter of its circumference or about .78 of an inch.

Number 2 shows the bobbin as two inches in diameter; the flyer has made one-half of a revolution, from A to B, and the bobbin has made one-quarter of a revolution, from C to D. The length wound is indicated by the distance measured around the bobbin, from D to E, which is 1.57 inches; twice as much as the empty bobbin.

Now, as the speed of the flyer is constant and the length of roving delivered is always the same, it is evident that the amount, wound upon the bobbin, can be only what is delivered by the front roll and as the larger the bobbin grows the greater is its circum-



ROVING FRAME — FRONT VIEW
Howard & Bullough Am. Machine Co. (Ltd.)

ference, the only way that the same length of roving can be wound is by increasing the speed of the bobbin so that the same ratio in its

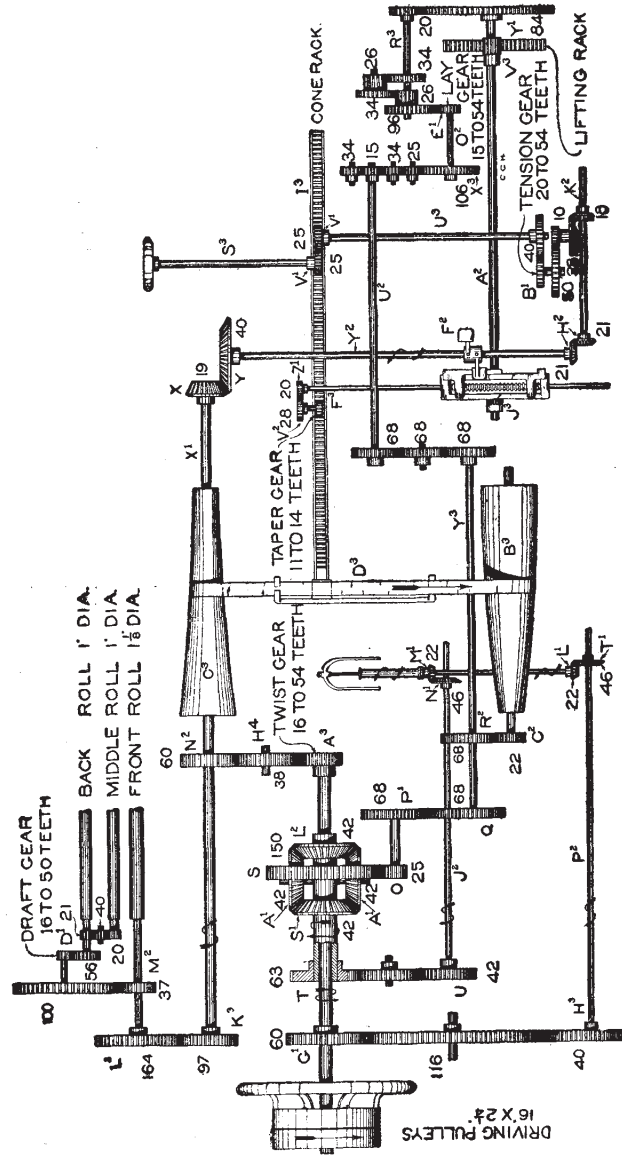

Fig. 164. Diagram of Fly Frame Gearing.

circumferential velocity shall be maintained at all times between it and the flyer.

Number 3 shows the bobbin as two inches in diameter, and, in order to wind the proper length of roving, it will have to make about three-eighths of a revolution. The length wound is represented by the distance, D-E, which, measured on the circumference of the bobbin, will be found to be the same as the distance D-E, in the first diagram.

The bobbin lead needs no further explanation than has been already given; the larger the bobbin grows, the slower it must run to wind the roving at the same speed, at all times.

Gearing. The reduction in the speed of the bobbin is accomplished by a pair of cones in connection with the differential gear, and to enable the student to follow clearly the gearing diagram, Fig. 164 has been made.

Speed of Flyer. The speed of the driving shaft, which is constant, is 400 R.P.M., and the flyers are driven from the driving shaft by the gears, G¹, H², T¹ and L¹. They therefore run 1254.54 R.P.M.

$$\frac{60 \times 46 \times 400}{40 \times 22} = 1254.54$$

Speed of Front Roll. The front roll, which is $1\frac{1}{8}$ inches in diameter, is also driven from the driving shaft by the gears, A³, N², K³ and L³. The speed of the front rolls remains constant, except when a change is made in the number of roving being spun. This is accomplished by changing the number of teeth in the twist gear, A³. For 3.50 hank roving, the twist gear should have 40 teeth. The speed of the front roll, therefore, is 157.72 R.P.M.

$$\frac{40 \times 97 \times 400}{60 \times 164} = 157.72 +$$

Speed of Empty Bobbin. The barrel of the empty bobbin is $1\frac{3}{8}$ inches in diameter and to wind onto its surface the roving delivered by the front roll, it must make 129.03 R.P.M.

$$\frac{157.72 \times 1.125 \text{ (diameter of the front roll)}}{1.375 \text{ (diameter of empty bobbin)}} = 129.03.$$

As we have seen, the speed of the flyer is 1254.54 R.P.M., and the speed of the empty bobbin, necessary to wind the roving, is 129.03 R.P.M.

Now, as the bobbins run at a greater speed than the flyers, the

actual speed of the bobbins must be added to that of the flyers. This will give 1383.57 R.P.M.

Revolutions of flyers	1254.54
Revolutions of empty bobbins necessary to wind roving	129.03
Actual revolution of empty bobbins	1383.57

When the bobbin is full, it is $3\frac{1}{2}$ inches in diameter and to wind the roving, it must make 50.69 R.P.M.

$$\frac{157.72 \times 1.125 \text{ (diameter of front roll)}}{3.5 \text{ (diameter of full bobbin)}} = 50.69 +$$

To this speed should be added, as before, the revolutions of the flyer, which makes the actual speed of the full bobbin 1305.23 R.P.M.

Revolutions of full bobbin required to wind roving	50.69
Revolutions of flyers	1254.54
Actual revolutions of full bobbin	1305.23

The next step is to find the revolutions of the sleeve gear, T, when winding upon the bare bobbin. The gears in the train are M¹, N¹, U and T. The sleeve gear makes 441.13 R.P.M.

$$\frac{1383.57 \times 22 \times 42}{46 \times 63} = 441.13$$

With the full bobbin, the revolutions of the sleeve gear will be 416.16 R.P.M.

$$\frac{1305.23 \times 22 \times 42}{46 \times 63} = 416.16$$

Now, we must find the revolutions of the sun wheel, S, but before this is done, it will be necessary to refer to the compound, or differential gearing shown in an enlarged view in Fig. 165. The purpose of this train of gears is to connect the positive driving of the flyers with the necessarily varying speed of the bobbins by a pair of cones and a belt.

The sleeve gear, T, runs upon a bushing on the driving shaft, and turns in the opposite direction from it, as indicated by the arrows. The two mitre gears, A¹, of forty-two teeth, are carried by a cross, the extended arms of which form bearings for the gears to turn upon. The sun wheel and cross are fastened together and

turn upon a bushing on the driving shaft, the same as the sleeve gear. The mitre gear, L^2 , is fast upon the driving shaft and the mitre gear, S^1 , is fast upon the hub of the sleeve gear.

The gears, S^1 and L^2 , turn in opposite directions and, if they are run at the same speed, the sun wheel will remain stationary. But if S^1 is run at a greater speed than L^2 , each revolution it makes in excess of L^2 will cause the sun wheel to make one-half of a revolution in the same direction as S^1 .

To illustrate this: If S^1 is given four revolutions and L^2 , two

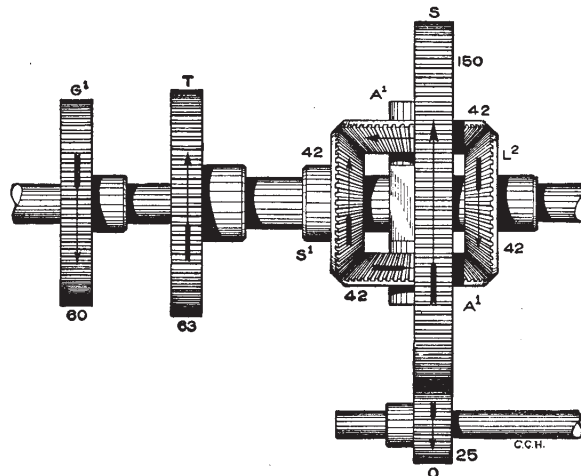

Fig. 165. Fly Frame Differential Gearing.

revolutions, in the opposite direction, the sun wheel will turn one revolution or one-half the difference between the revolutions of the gears, S^1 and L^2 , but in the direction of S^1 .

The speed of the driving shaft is 400 R.P.M. and, as we have found, the speed of the loose sleeve is 441.13 R.P.M. but in the opposite direction. The sun wheel, then, must make 20.56 R.P.M., which is one-half the difference between the speed of the driving shaft and the speed of the sleeve gear.

With the full bobbin, the sleeve gear makes 416.16 R.P.M., which is 16.16 revolutions more than the speed of the driving shaft. The speed of the sun wheel will be 8.08 R.P.M., a difference of only 12.78 revolutions between the full and the empty bobbin.

We must find next the revolutions of the bottom cone, B^2 , for

both the full and the empty bobbin. The sun wheel is driven from the bottom cone by the gears, C², R², Q, P¹ and O. Starting with 20.56 revolutions we get 187.04 + R.P.M. for the bottom cone.

$$\frac{20.56 \times 150 \times 68 \times 68}{25 \times 68 \times 22} = 381.29 +$$

With the full bobbin, the speed of the bottom cone will be 149.84 + R.P.M.

$$\frac{8.08 \times 150 \times 68 \times 68}{25 \times 68 \times 22} = 149.84 +$$

Cones. We will find next the sizes the cones must be to give the necessary range in speed. The top or driving cone, C³, is driven from the driving shaft by the gears, A³, H⁴ and N². A³ is the twist gear, as already mentioned. The speed of the top cone is 266.66 + R.P.M.

$$\frac{400 \times 40}{60} = 266.66 +$$

The diameter of the large end of the top cone is six inches and the small end three inches. The bottom cone is the same in diameter at the ends as the top cone. With the cone belt upon the large end of the top cone, the speed of the bottom cone will be 533.33 + R.P.M.

$$\frac{266.66 \times 6}{3} = 533.33 +$$

With the cone belt at the small end of the top cone, the speed of the bottom cone will be 133.33 + R.P.M.

$$\frac{266.66 \times 3}{6} = 133.33 +$$

With the cones of the diameter, at the ends, as given above, the difference in the extreme speeds of the bottom cone is 400 R.P.M. and the difference in the speeds, required to wind a full bobbin, is 231.45 R.P.M.

The cones may be made any diameter or length consistent with the allotted space in the machine, but the difference between the diameters of the small and large ends must be more than enough to give the extreme speeds necessary to wind a bobbin.

The faces of the cones are curved, the top cone concave and the bottom cone convex.

inches in circumference, there will be wound 3768 inches of roving.

$$3.14 \times 1200 = 3768.$$

When eight layers have been added, the bobbin will be two inches in diameter or 6.28+ inches in circumference and to wind 3768 inches of roving, its speed must be 600 R.P.M.

$$\frac{3768}{6.28} = 600.$$

The belt will have made eight shifts along the cone, from A to B, and the speed of the bottom cone will be 200 R.P.M.

When sixteen layers of roving have been wound the diameter of the bobbin will be three inches and the circumference will be 9.42 inches. To wind 3768 inches, its speed must be 400 R.P.M.

$$\frac{3768}{9.42} = 400.$$

The belt will have moved from B to C and the speed of the bottom cone will be 133.33 R.P.M.

When the bobbin is full, twenty-four layers have been added to make four inches in diameter and its circumference will be 12.56 + inches. The speed must be 300 R.P.M.

$$\frac{3768}{12.56} = 300.$$

The movement of the cone belt, from A to B, is one-third the length of the cones, but the speed of the bobbin decreases one-half, from 1200 to 600 R.P.M. From B to C the distance is one-third and the bobbin decreases in speed from 600 to 400 R.P.M., only one-third. The remaining distance, C-D, is one-third and the speed decreases from 400 to 300 R.P.M. or one quarter the number of revolutions.

If the roving were twice the diameter, it would be necessary to shift the cone belt just twice as far along the cones and there would be four layers, only, for each inch added to the diameter of the bobbin.

Reversing Motion. The reversing motion, commonly called rail motion and traverse motion, is the mechanism employed to change the direction of the bobbin rail at each end of the traverse.

At the beginning of a set, the rail moves its greatest distance and the roving is wound nearly the whole length of the bobbin, as shown in

Fig. 167, by the distance C—D. As each layer is added, the traverse of the rail is shortened, slightly, until, at the completion of the building of the bobbin, it is a little more than one-half as much as at the start. This is shown by the distance E—F. The amount that the traverse is shortened is governed by the taper gear F^3 (shown in Fig. 168), and the speed that the rail is traversed, by the lay gear E^1 .

It is desirable to get as much roving upon a bobbin as possible, as the machine will not have to be doffed as often but, at the same time, if the traverse is not shortened enough, the ends of the bobbins will be too square, and the layers of roving will be apt to "slough off" and the roving break when unwound.

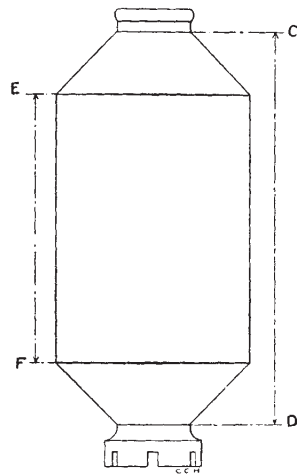

Fig. 167. Fly Frame Bobbin.

The reversing motion is shown in Figs. 168, 169, 170, 171 and 172.

On the end of the top cone shaft, X^1 , is a bevel gear, X, of nineteen teeth and upon the top of the tumbling shaft, Y^2 , is a bevel gear, Y, of forty teeth, called the gap gear from the fact that several teeth are omitted on opposite sides in its diameter, leaving spaces in which the gear on the cone shaft can revolve without imparting motion to the tumbling shaft.

Lower, on the tumbling shaft is the tumbling dog, F^2 , and on the extreme lower end is a mitre gear, H^2 .

On the horizontal shaft, K^2 , called the reverse shaft, is the reverse crank, T^2 , starting cam, W, and mitre gear, H^2 . The last is in gear with the gear, H^2 , on the tumbling shaft.

Builder. The builder, which should be described in connection with the reversing motion, consists of a main piece, B^2 , builder screw, D^2 , with right and left threads, builder rack, P, and top and bottom jaws, V, and, X^2 . A gear J^2 , which is upon the lifting shaft, A^2 , is in contact with the builder rack. The rotations of the lifting shaft cause the builder to slide up and down on the guide rod, W^1 .

On the stem of the builder screw is a gear, Z^1 , of twenty teeth, which is driven from a similar gear, V^2 , of twenty-eight teeth, which is upon the stud with the taper gear, F^3 . Motion is given to the builder

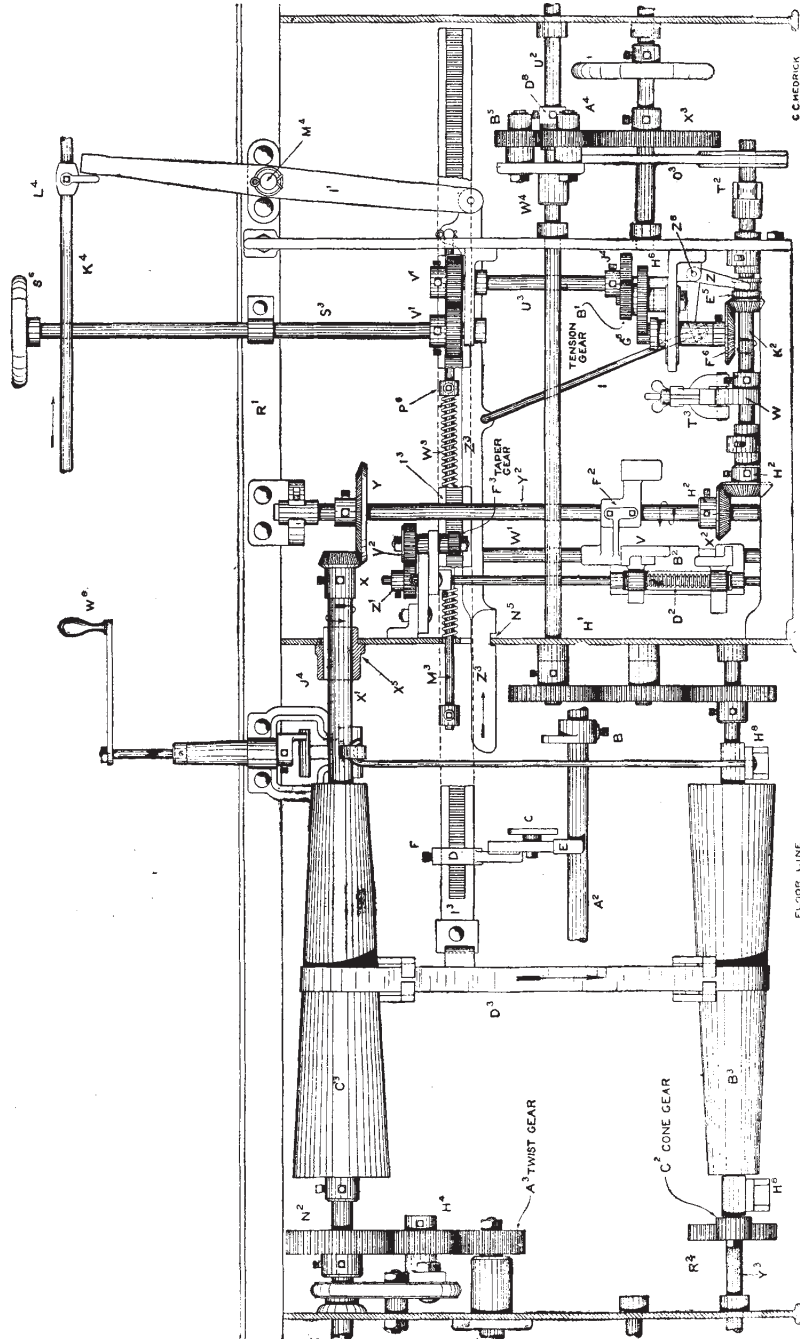

Fig. 168. Reversing Motion and Builder.

screw from the cone rack, I^3 , by the taper gear. At each end of the traverse, the builder screw is turned a trifle and the jaws are brought more closely together. The builder and parts directly connected are shown on an enlarged scale in Fig. 170.

When the bobbin rail is moving upward, the builder is moving in the opposite direction. In the drawing, Fig. 170, we will assume that the builder is going downward. The upper arm of the tumbling dog, F^2 , is pressed firmly against the top builder by the starting spring, U^1 . When the builder descends enough to clear the arm of the tumbling dog, several changes take place instantly.

The starting presser, T^3 , which is actuated by the spring, U^1 ,

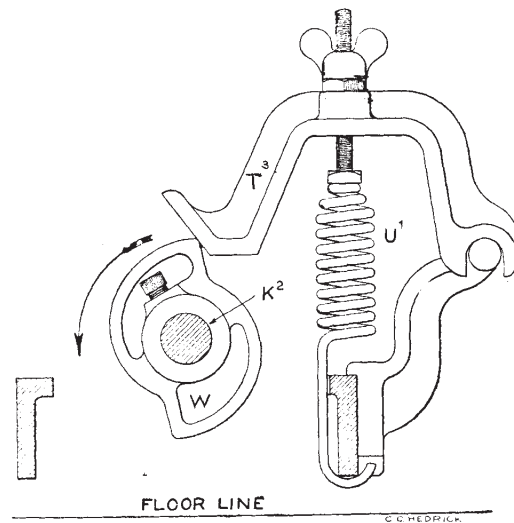

Fig. 169. Elevation Showing Starting Cam.

turns the tumbling shaft slightly so that the bevel on the top cone shaft, which is revolving rapidly, engages the toothed portion of the gap gear and gives the tumbling shaft one-half of a revolution.

The reverse shaft, which is driven from the tumbling shaft, also turns half around and shifts the reverse gearing, changing the direction of the bobbin rail.

The tension gearing, which is driven from the bevel gear, E^3 , on the reverse shaft, is turned a little and the cone rack is moved and shifts the belt along the cones.

The taper gear is driven from the cone rack, and is turned part of

a revolution, and the builder jaws are brought together more closely, thus shortening the traverse of the rail.

All these movements take place simultaneously, the half revolution of the tumbling shaft brings the opposite space in the gap gear

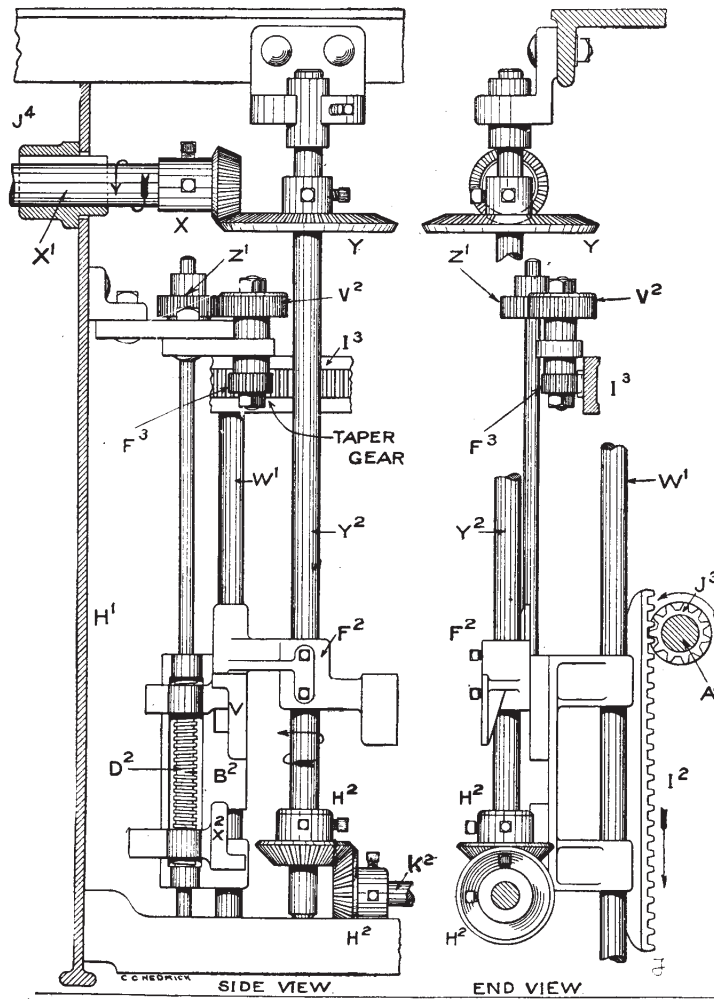

Fig. 170. Builder.

under the top cone shaft bevel, and the lower arm of the tumbling dog is brought up against the lower builder jaw, where it is held firmly by the starting cam and presser. This leaves the various parts in position to operate, when the end of the traverse is reached again.

The drawings of the reverse gearing, in Figs. 171 and 172, show the method employed to change the direction of the traverse of the rail.

On the reverse shaft, K^2 , is a crank, T^2 , which works in a slot in the end of the reverse arm, O^3 . The upper part of this arm is connected to a plate, W^4 , which is mounted upon the shaft, U^2 , and carries studs upon which are the gears, A^4 , B^5 and C^6 . The gear X^3 , is upon

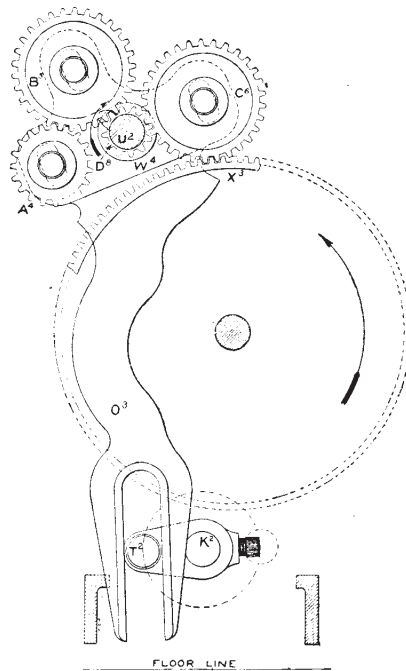

Fig. 171. Elevation Showing Reverse Crank and Gearing.

the lay shaft and D^8 is upon the shaft, U^2 . The connection of these shafts and gears with the lifting shaft is shown in the diagram of gearing (Fig. 164).

When the rail is rising, the lifting shaft is driven through the gears, D^8 and C^6 , and gear, X^3 , is turned in the direction, indicated by the arrow in Fig. 171. But when the reverse shaft makes the half revolution, the crank shifts the reverse arm, which turns about the shaft U^2 , as a center, to the position shown in Fig. 172. This throws C^6 out of contact with X^3 , and A^4 into contact with it, and X^3 is driven by the gears, D^8 , B^5 and A^4 , which results in changing the direction of the lay shaft, as may be seen by comparing the two drawings.

The teeth of X^3 , C^6 and A^4 are made pointed so that they may engage readily. This overcomes also, in a measure, the danger of breaking, always liable to occur with involute teeth if the points come into contact.

Tension gearing for fly frames is shown in Fig. 173 and, to make this drawing as simple as possible, all parts, which are not required in explaining the device, are omitted. Reference should also be made to Fig. 168.

The cone rack, I^3 , is driven from the reverse shaft, K^2 , by the gears, E^5 , F^6 , G^5 , H^6 , B^1 , J^4 and V^1 . The bevel, E^5 , is keyed to the reverse shaft but is free to slide in and out of gear with F^6 .

When the machine is started, the shipper rod, K^4 , is moved in the direction of the arrow and the dog, L^4 , comes in contact with the stop-motion arm, I^1 , which turns about the stud, M^4 . This moves the stop motion latch, Z^3 , so that the notch, N^5 , catches on the support, H^1 , and holds the latch in place.

The bevel, E^5 , is formed with an annular groove in which is a fork, Z , pivoted to a stand at Z^6 . The upright arm of the fork is connected with the stop motion latch by a rod, I . In starting the frame, the movement of the latch draws the gear, E^5 , into contact with F^6 . This completes the train of gears so that the half revolution of the reverse shaft, which takes place at each end of the traverse, causes the cone belt to be moved to a different place on the cone.

The gear, B^1 , is the tension gear, which is changed to give the correct distance that the cone belt must be moved, and, as this gear is a driver, the greater number of teeth it contains, the greater will be the distance that the cone belt is moved.

When the attendant wishes to stop the machine, the shipper rod

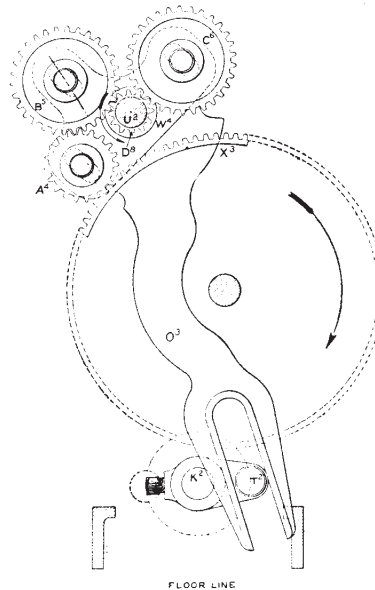

Fig. 172. Elevation Showing Reverse Crank and Gearing.

drawing of the reverse motion and builder Fig. 168, consists of three pieces, a bracket, D, lifter, C, and cam, B.

The bracket, which is fastened to the cone rack, I^3 , by a screw, F, carries the lifter, and the cam is fastened to the lifting shaft, A^2 , at a point directly under the end of the stop-motion latch, Z^3 , which projects through the rectangular slot in the support, H^1 .

As the lifting shaft revolves, the cam is brought into contact with the lifter, forcing it upward against the underside of the stop-motion latch and lifting the latch so that the notch, N^5 , in its underside, is clear of the support.

The stop-motion spring, W^2 , is mounted upon the spring rod, M^3 . One end of the spring bears against the support and the other end

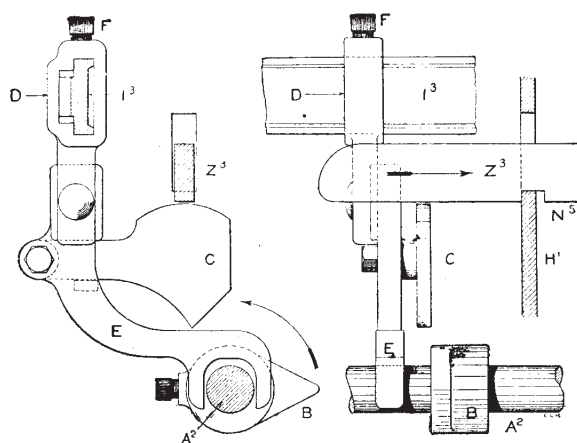

Fig. 174. Full Bobbin Stop Motion.

against a collar, P^6 , which is fastened to the rod and which may be set to increase or decrease the tension upon the spring. The free end of the spring rod passes through a hole in the support, and the other end is connected to the stop-motion latch.

When the notch in the latch is clear of the support, the spring rod pushes the latch in the direction shown by the arrow and this movement is communicated to the shipper rod by the shipper arm, I¹.

When the frame is to be doffed, the attendant raises the bottom cone, B^3 , by turning the cone raise handle, W^8 , a half revolution. This leaves the cone belt free and the cone rack is moved back, for starting a new set of bobbins, by turning the hand wheel, S^6 . A collar on the

rack comes against a stop, which insures the belt starting in the same position, on the face of the cone, for each set.

When the stop motion operates, the movement of the lever, Z^3 , disconnects the tension gearing by sliding E^3 out of contact with F^6 . This allows the cone belt to be wound back which cannot be done with these gears in contact, and as the builder screw is driven from the cone rack, the winding back of the rack opens the builder jaws.

Before doffing, the frame is started with the bottom cone raised and a few inches of roving are delivered by the front roll to be used for

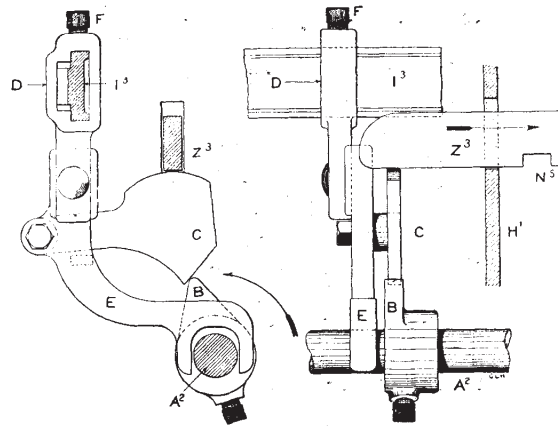
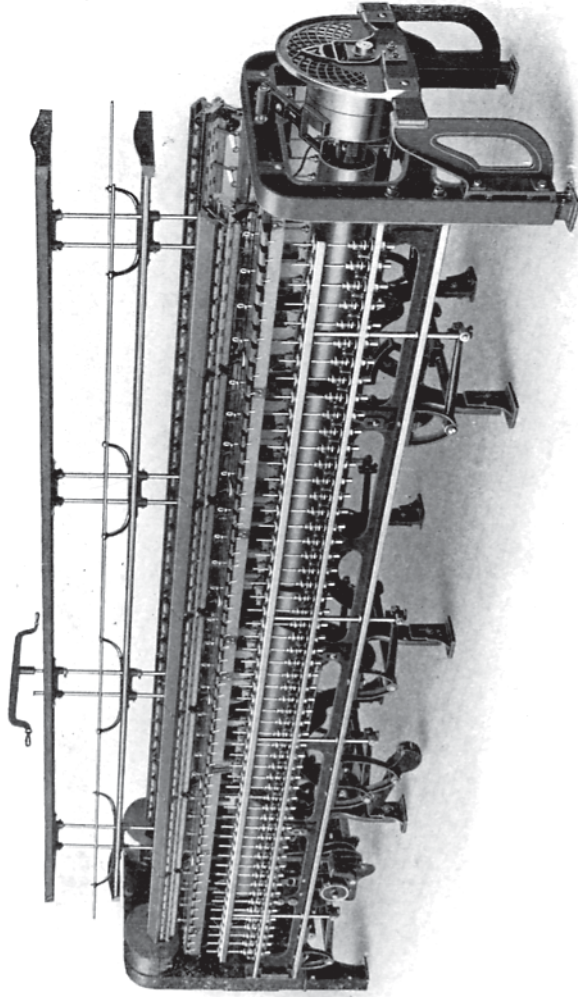

Fig. 175. Full Bobbin Stop Motion.

twisting around the empty bobbins. The bobbins are driven from the bottom cone through the differential gearing and, with the cone raised, they do not revolve, consequently, the roving is not wound.

The power for driving the bobbins and the traverse of the rail is transmitted through the cone belt and, for this reason, there must be as little slip as possible to this belt. The bottom cone is iron and it is carried in a frame, H^3 , called the cone swing frame. It is hung from the shaft, Y^3 . The weight of the cone hangs upon the cone belt, D^3 , and keeps it tight.

The connection, from the bottom cone to the gearing, is through the cone gear, C^2 , which has twenty-two teeth. This gear is sometimes changed when the diameter of the empty bobbin is so small that the difference in the diameters of the cones, with the belt upon the large end of the top cone, is not sufficient to wind the roving. When this is the case, a cone gear of more teeth is put on the cone, which causes



SPINNING FRAME DESIGNED FOR HIGH SPEED

Howard & Bullough Am. Machine Co. (Ltd.)

the bobbins to run at a greater speed. The cone belt is then shifted along the cones until the position of the belt is such that the roving "takes up" or winds correctly.

The taper gear, F^3 , has from eleven to fourteen teeth. This is a driven gear and the fewer teeth it has, the faster the builder jaws close. The end bearing, X^5 , for the top cone shaft, is open on the top so that the cone may lift, if the tops of the teeth come together, when the gap gear is thrown in.

Back Stop Motion. Sometimes, a back stop motion is applied to the slubber, so the machine will stop when an end is out, but is not applied to any other fly frame. By many, a back stop motion is con-

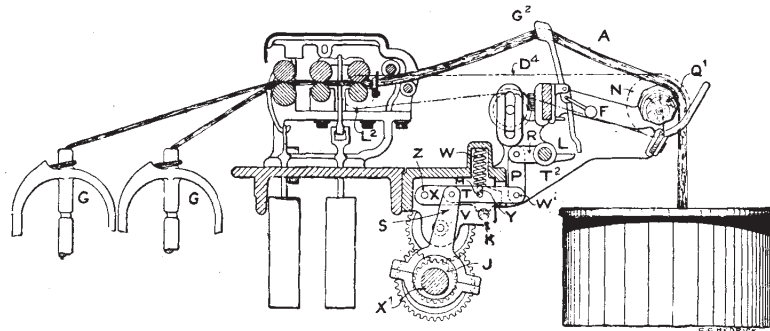

Fig. 176. Section of Fly Frame Showing Back Stop Motion.

sidered unnecessary because if there is none, the attendant will watch for a broken end in the sliver, and will anticipate a can becoming empty and piece the sliver onto a full can, whereas, with a stop motion, he knows the machine will stop when an end is out and he becomes inattentive and allows the machine to stand idle too long before piecing up.

Fig. 176 shows a section of a slubber fly frame fitted with a back stop motion. The sliver, A, is lifted out of the cans by the carrier roll, Q^1 , and passes over the stop-motion spoon, G^2 , and between the three pairs of draft rolls to the flyer, G.

Directly beneath the tail of each spoon is a finger L, mounted on the rocker shaft, T^2 . Motion is given to the rocker shaft from an eccentric, J, which runs loose upon the top cone shaft, X^1 , but is driven from the top cone shaft by a train of gears. By this means the eccentric is given a much slower speed than the cone shaft.

The carrier roll, Q^1 , is driven from the end of the back roll by the

sprocket chain, D⁴, and the sprocket wheels, I² and N. The connection between the rocker shaft and eccentric is through the eccentric arm, S, rocker, T, link, P, and, arm, R.

The rocker is hung in the bottom of a slot, Y, in the stand, V, and the pin, M, upon which the rocker is hung, projects into a hole in the lever, X, and in its normal position, is kept from rising by the spring, W. The arm, R, is keyed to the rocker shaft which is given a reciprocal motion by the revolutions of the eccentric.

The stop-motion spoons are mounted in stands and are so balanced that the friction of the sliver,

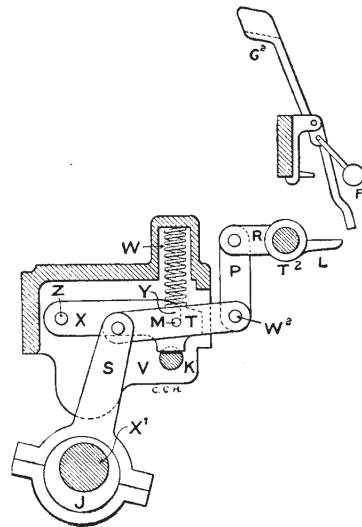

Fig. 177. Back Stop Motion.

in passing over them, holds the tails clear of the path of the finger, L.

When the machine is started the spring rod, K, which moves with the shipper rod, slides along until a slot in its upper surface is beneath one end of the lever, X. When this happens, X, which is pivoted at Z, drops into the slot and holds the rod stationary until X is lifted out of the slot.

If a sliver breaks or runs out, the spoon assumes a vertical position, immediately, and the tail is brought into the path of the finger which arrests the movements of the rocker shaft. As soon as this occurs, the fulcrum of the rocker, T, is transferred from the pin, M,

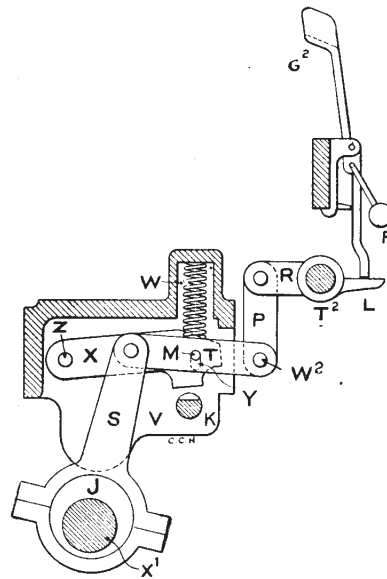

Fig. 178. Back Stop Motion.

in the slot of the stand, to the pin, W^2 , in the lower end of the link, P. The spring, W, yields and allows the eccentric to lift the pin, M, and with it the lever, X, withdrawing X from the slot in the spring rod, which is released and the belt is shipped.

Figs. 177 and 178 show the positions of the levers when the machine is running and when the stop motion operates. A weight, F, mounted upon a rod, may be moved in or out as a counterbalance for the spoon G² to accommodate a heavy or light sliver.

The roll stand, for carrying the steel fluted rolls, is shown in Fig.

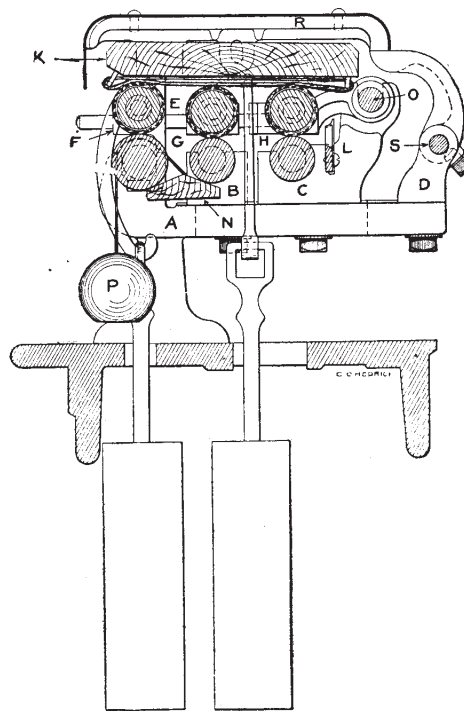

Fig. 179. Roll Stand.

179. This stand consists of four parts: the main piece, A, the two slides or bearings, B and C, for the middle and back rolls, and the bracket, D, upon which the top roll clearer is hinged. The bearing for the front roll is usually lined with bronze as the wear on the front roll's bearing is much greater than upon the bearings for the other rolls.

The slides are screwed to the main part of the stand and are ar-

ranged so that they may be adjusted to suit the various lengths of staple. The slide for the back roll is slotted for a bearing for the roving traverse rod, L, and for the rod, O, upon which the wires, E, supporting the cap bar nebs F, G, and H, are fastened. The front neb, F, is made with projections above and below. The upper one serves as a stop for the top clearer and the lower one as a support for holding the nebs on center with the axis of the top rolls. A detached view of the cap bar is shown in Fig. 180.

The wires, E, are flattened, slightly, upon the upper surface, where the screws bear, to hold the nebs in place, which insures their standing perfectly true with the top rolls.

The spaces in the nebs into which the gudgeons of the top rolls

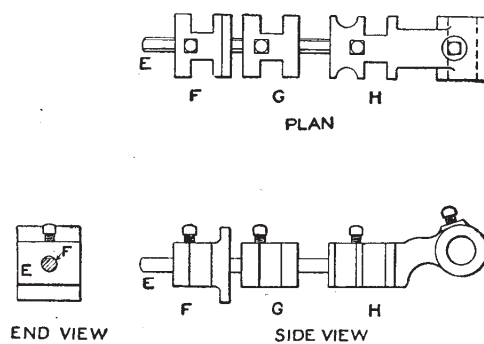

Fig. 180. Cap Bar.

project, are made wide enough to allow perfect freedom to the top rolls but with not enough play to allow them to get out of line with the steel rolls.

The top rolls, for the front line, are usually shell rolls and for the middle and back lines, solid rolls. The top roll clearer is shown in Fig. 179 and is similar to the common clearer used upon the drawing frame. A flat board, K, is faced on the underside with clearer cloth, supported by wires. The board, which is carried in a frame, R, is hinged upon the rod, S, and is hung so that it adjusts itself to the position of the top rolls. The under clearer, N, which is seldom used upon anything but the slubber fly frame, is held in place by straps which have a weight, P, suspended from the end.

Sometimes, self-weighted top rolls are used on fly frames intended for working long stock and for fine counts of yarn. A roll stand, with

top rolls of this kind, is shown in Fig. 181. The front and back steel rolls are one and one-quarter inches in diameter and the middle roll is one and one-eighth inches in diameter. The front top roll is the usual shell roll, weighed in the ordinary way by a hook, A, stirrup, B, and weight, C.

The middle top roll usually is made of thin, brass tubing, one and

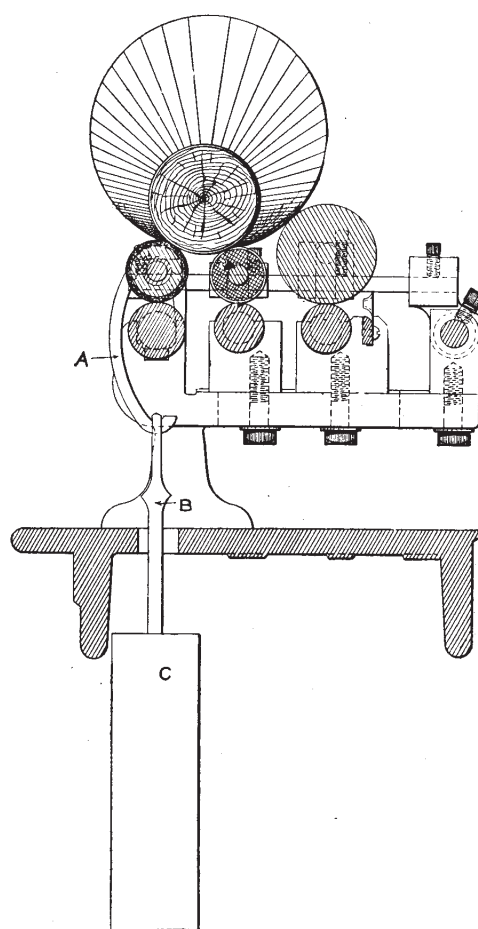

Fig. 181. Roll Stand for Self-Weighted Top Rolls.

one-eighth inches in diameter, filled with lead to give it additional weight, and sometimes of cast iron. The gudgeons, for this roll, are of iron wire put through the lead.

The back top roll is made of cast iron, two inches to two and one-half inches in diameter. Both of the top rolls are sometimes covered with leather.

The top clearers for self-weighted rolls are usually rotary, either conical or straight. They are shown in Fig. 182.

The conical clearer roll is made of wood, covered with clearer



Fig. 182. Top Clearer Rolls.

cloth. The large end bears upon all of the top rolls and the small end bears upon the middle and front rolls only. As the front roll runs at a much greater speed than the middle and back rolls, the clearer must partake of an intermediate speed to collect the loose fibers. When the frame is in operation, the conical shape of the clearer causes it to travel along the rolls slowly. Upon reaching the end of the frame, it is

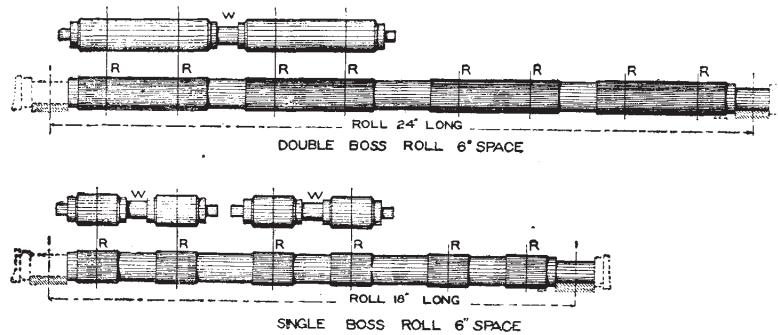

Fig. 183. Single and Double Boss Rolls.

reversed by the attendant and it works back to the other end. A straight roll is sometimes used with the conical roll, placed ahead and pushed along by it.

When straight clearer rolls are used, they are made of a diameter to bear upon all of the top rolls. They are made in short lengths, two for each roll stand.

Fluted Rolls. The fluted rolls, for slubbers and intermediate fly frames, are made "single boss." For fly frames of five and a quarter and six inch space, they are made either "single boss" or "double

boss", but for all fly frames under five and a quarter inch space they are made "double boss" only.

The terms "single boss" and "double boss" mean the number of ends of roving to each fluted boss of the roll. On a slubber, nine and one-half inch space, the rolls are nineteen inches long, which is the distance between the centers of the roll stands. There are four bosses

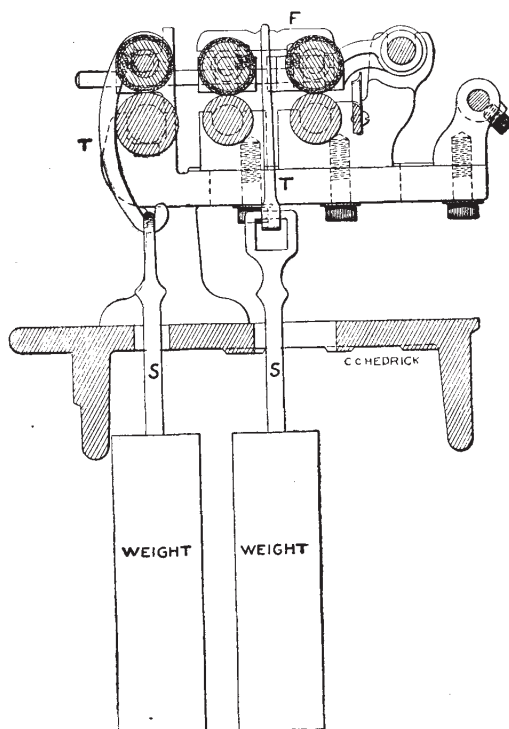

Fig. 184. Weighting for Top Rolls.

and four spindles in this length and one end of roving for each boss or single boss.

On a fly frame, four and one-half inch space, the length of the roll is eighteen inches. There are eight spindles in this distance, which is too short to allow eight separate bosses and still have room for the weight stirrups and saddles, which must hang between every two bosses. To provide for this, the rolls are made with bosses long enough to permit of two ends of roving, side by side, or "double boss."

Fig. 183 shows two steel fluted rolls for a six inch space fly frame

and the leather covered top rolls for each roll. The upper fluted roll is double boss and is twenty-four inches long and the lower one is single boss and is eighteen inches long. There are four bosses and eight ends for the double boss and six bosses and six ends for the single boss. The roving is represented by the lines, R, and the weight is hung between the bosses at W. There is one weight for four ends on the double boss and one weight for two ends on the single boss. The double boss rolls are seldom, if ever, used on any space more than six inches, as the length of the boss would be so great that the weights would have a tendency to spring the steel rolls enough to cause the top rolls to bear unevenly.

The usual method of weighting the top draft roll is shown in Figure 184. For the front roll a separate weight is used which is hung from a stirrup, S, and hook, T. For the middle and back rolls, the weight is divided. The stirrup is hung from a saddle, F, by a hook, T, and the saddle bears upon the middle and back top rolls.

For the slubbers, eight and one-half inch space and over, weights are usually eighteen pounds. For intermediate frames, they are seventeen pounds and for fine frames, seventeen pounds. For single boss rolls, six inch space, they are twelve pounds. For fine frames, five and one-quarter inch space or under, and all jack frames, the weights are fifteen pounds. Sometimes a separate weight is used for each roll. The weights may then be:

	Front Roll	Middle Roll	Back Roll
Slubber - - -	18	14	10
Intermediate - -	14	10	8
Fine and Jack - -	10	8	6
Double Boss Fine Frame	18	14	12

Fly frames are built both right and left hand. A frame is said to be right hand, when, in standing on the front or spindle side and facing the machine, the pulley is on the right hand end.

By the gauge or space of a fly frame is meant the distance between the centers of two adjoining spindles in the same row. The slubbers are built eight and one-half inch, nine inch, nine and one-half inch, and ten inch space. Intermediates are built seven inch, and seven and one-half inch space. Fine frames are built five and one-quarter

inch and six inch space; and jack frames, three and three-quarters inch, four and one-quarter inch, and four and one-half inch space.

Frame	Space	Size of Bobbin	Speed of Flyer	No. of Spindle per Roll	Weight of Cotton on Full Bobbin	Length of Roll	Traverse of Frame
Slubber	10"	6" x 12"	625	4	44 oz.	20"	12"
Slubber	9½"	5½" x 11"	700	4	32 oz.	19"	11"
Slubber	9"	5" x 10"	750	4	24 oz.	18"	10"
Slubber	8½"	4½" x 9"	800	4	18 oz.	17"	9"
Intermediate	7½"	5" x 10"	825	6	24 oz.	22½"	10"
Intermediate	7"	4½" x 9"	950	6	18 oz.	21"	9"
Fine	6"	4" x 8"	1100	8	14 oz.	24"	8"
Fine	5¼"	3½" x 8"	1250	8	12 oz.	21"	8"
Fine	5¼"	3½" x 7"	1250	8	10 oz.	21"	7"
Jack	4½"	3" x 6"	1400	8	7 oz.	18"	6"
Jack	4¼"	2½" x 5"	1600	8	4 oz.	17"	5"
Jack	3¾"	2½" x 4½"	1800	12	3 oz.	22½"	4½"

The fluted rolls for fly frames are made of the diameters shown in Fig. 185. Those most commonly used for medium staple cotton are shown in the upper view in the drawing. For Egyptian and Sea Island cotton, the rolls are usually larger and of the diameters shown in the middle drawing. For self-weighted top rolls, the usual diameters are shown in the lower drawing. The diameter of the back top roll is made from two to two and one-half inches to suit the weights of the sliver. A heavy sliver and a long draft require the largest sized roll.

Fig. 186 shows the sizes and dimensions of fly frame bobbins. The dimensions vary but slightly for the different makes of fly frames. The bottom of the bobbin is made with both four and six notches for the dog or bobbin driver. The bobbins shown in the diagram have six notches. To prevent splitting, the bottoms are either brass bound or wired.

It is very necessary that the diameter of the holes in the bobbins shall be exact, and to avoid any mistakes, most mills have a standard plug for each sized bobbin used, made similarly to the one shown in the upper right hand corner of the drawing. This plug is made the small end for the spindle hole, the large end for the bolster gear and the

intermediate for the bolster hole. The diameter of the spindle hole is about one sixty-fourth of an inch greater than the diameter of the spindle; the hole in the bottom of the bobbin is one thirty-second of an inch larger in diameter than the bobbin gear, and the bolster hole is about one-sixteenth of an inch larger in diameter than the bolster.

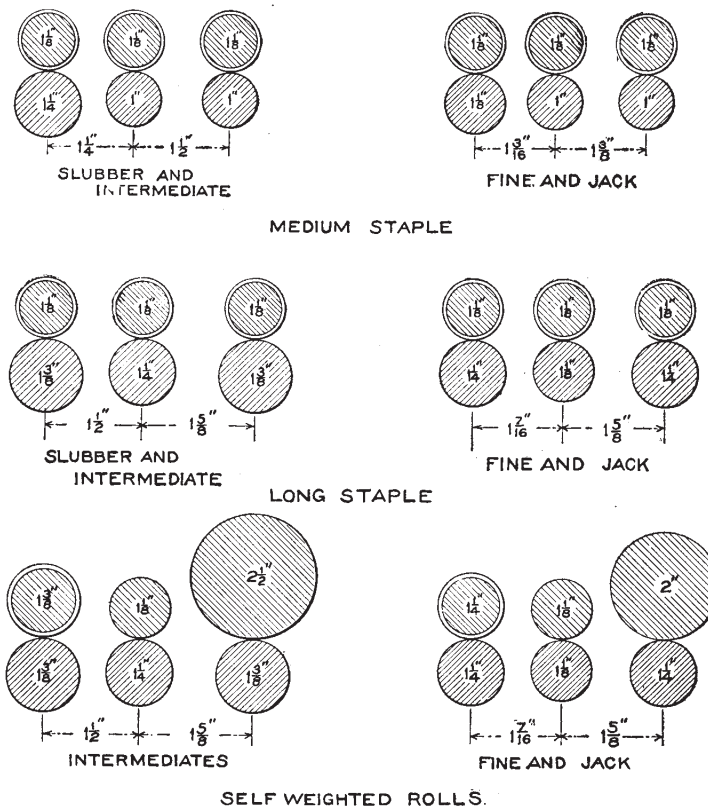

Fig. 185. Sizes of Steel Fluted Rolls.

To find the length of a fly frame: Multiply one half the number of spindles by the space in inches and add 38 inches.

The power required to drive fly frame spindles is as follows:

Slubbers	35 to 45 spindles per H. P.
Intermediates	65 to 75 " " "
Fine and Jack frames	95 to 105 " " "

Calculations. The general diagram of fly frame gearing, given

in Fig. 164, shows all of the gears necessary in calculations, but, to avoid confusion, the draft gearing is shown separately in Fig. 187 and the twist gearing in Fig. 188.

Rule 1. To find the draft of the fly frame: Multiply together the driven gears and the diameter of the front roll and divide the product by the product of the driving gears multiplied together with the diameter of the back roll. (The driven gears are E^3 and O^1 and the driving gears are M^2 and D^1 .) The front roll is $1\frac{1}{8}$ inches in diameter and the back roll is 1 inch in diameter.

$$\text{Example: } \frac{100 \times 56 \times 9}{37 \times 34 \times 8} = 5.00$$

Rule 2. To find the draft factor: Proceed as in the previous rule, but omit the draft change gear D^1 .

$$\text{Example: } \frac{100 \times 56 \times 9}{37 \times 8} = 170.27$$

Rule 3. To find the draft: Divide the factor by the number of teeth in the draft gear.

$$\text{Example: } \frac{170.27}{34} = 5.00$$

Rule 4. To find the draft gear: Divide the factor by the draft.

$$\text{Example: } \frac{170.27}{5} = 34$$

The draft between the back roll and the middle roll is very slight and is only the difference of one tooth in the gears, as will be seen by referring to the diagram. On the back roll is a gear of 21 teeth and on the middle roll is a gear of 20 teeth.

Sometimes the crown gear is changed, as well as the draft gear, when a very fine adjustment in the draft is needed, and a difference of one tooth in the draft gears makes too great a change in the draft.

The definition of the word twist, as used in reference to yarn and roving, is the number of turns that the spindles or flyers make to each inch of roving that is delivered by the front roll. If the spindles make 100 revolutions and the front roll delivers 40 inches of roving, the twist will be 2.5 per inch. $100 \div 40 = 2.5$.

Rule 5. To find the twist per inch: Multiply together the driven gears and divide the product by the product of the driving gears multi-

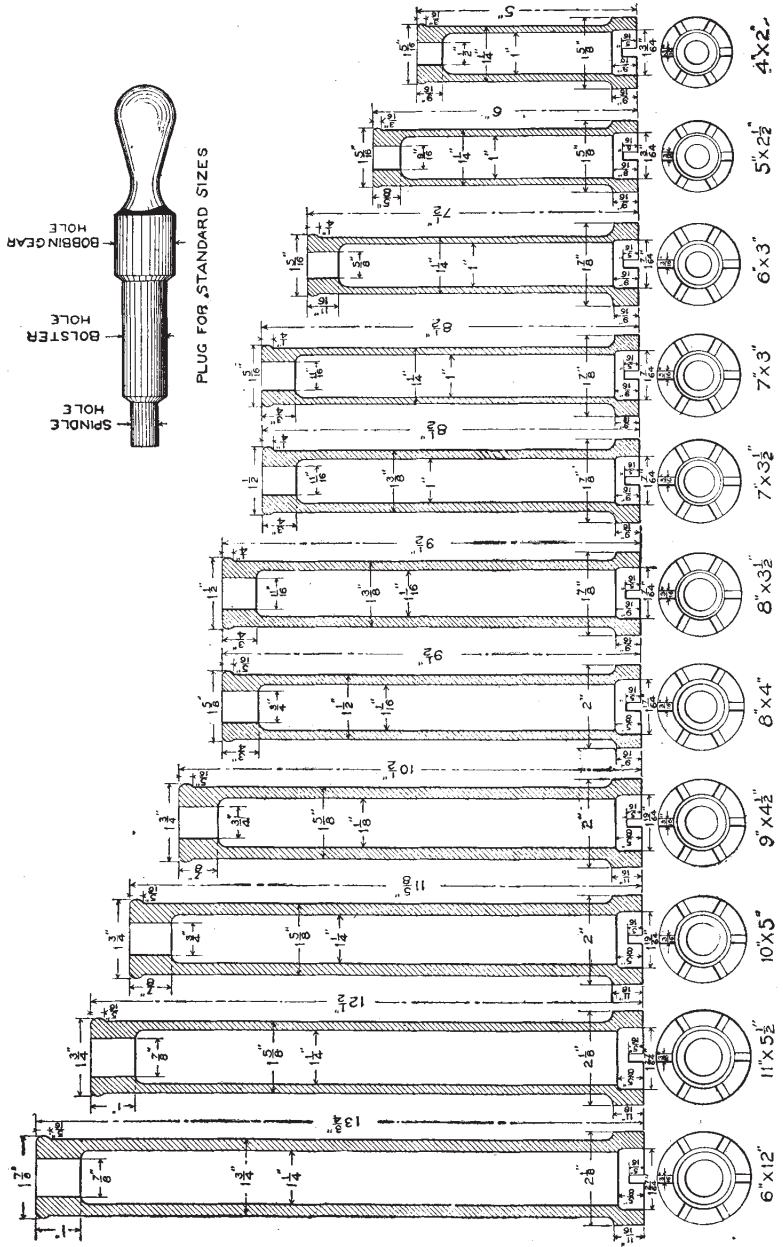

Fig. 186. Sizes of Fly Frame Bobbins.

plied together with the circumference of the front roll. Assuming the twist gear to be a driving gear, the driven gears are L³, N², G¹, and T¹. The driving gears are K³, A³, H³, and I¹, and the circumference of the 1 $\frac{1}{8}$ inch front roll is 3.5343 inches.

$$\text{Example: } \frac{164 \times 60 \times 60 \times 46}{97 \times 40 \times 40 \times 22 \times 3.5343} = 2.25$$

Rule 6. To find the twist factor: Proceed as in the previous rule but omit the twist gear.

$$\text{Example: } \frac{164 \times 60 \times 60 \times 46}{97 \times 40 \times 22 \times 3.5343} = 90.02$$

Rule 7. To find the twist: Divide the twist factor by the number of teeth in the twist gear.

$$\text{Example: } \frac{90.02}{40} = 2.25$$

Rule 8. To find the number of teeth in the twist gear: Divide the factor by the twist per inch.

$$\text{Example: } \frac{90.02}{2.25} = 40$$

The standard twist for roving is the square root of the hank multiplied by 1.2, and is expressed thus $\sqrt{\text{Hank}} \times 1.2$

This multiplier is the one that is used by most machinery builders in the construction of twist tables and is correct for cotton of ordinary length staple, but for Sea Island, Egyptian and other long staple cottons, the multiplier may be as low as .8, and for very short staple as high as 1.5.

All that is required is sufficient twist to hold the roving together, as too much twist destroys the effectiveness of the drawing operation in the successive processes.

When there is very little twist put into the roving, the production of the machine is increased as the speed of the spindles is constant and the front roll must run faster to give less twist.

There are several things to be considered in figuring the production of the fly frame; revolutions of spindle, hank roving, twist per inch, weight of cotton upon full bobbin and time lost piecing-up and doffing. With these factors known, we can find the approximate production.

First, it is necessary to find the time required to spin a set of

and divide the product by the number of grains in one pound (7000)

Example:
$$\frac{4.02 \times 4375}{7000} = 2.51$$

The time required to doff a machine will vary from ten to twenty minutes according to the number of spindles in the frame and the skill

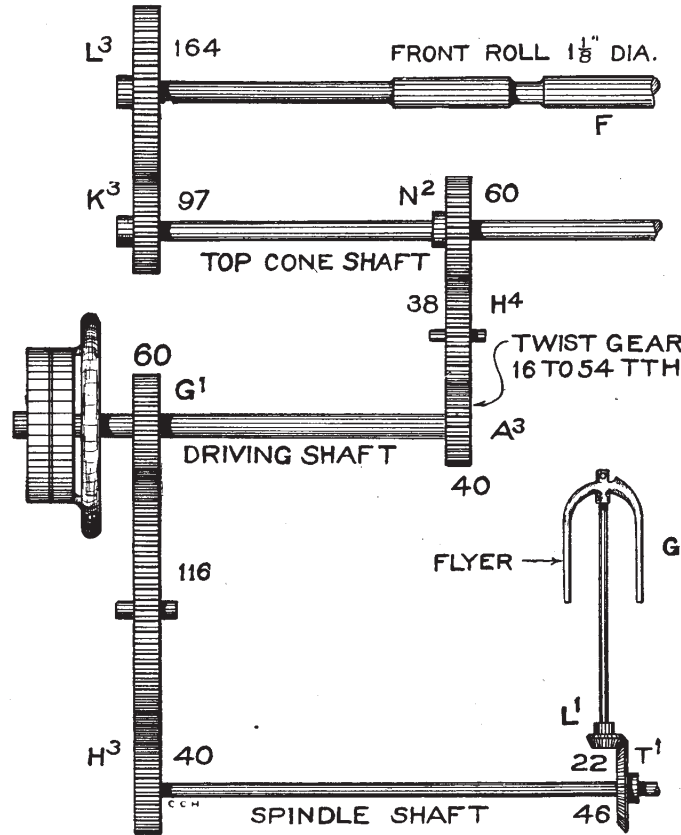

Fig. 188. Diagram of Twist Gearing.

of the attendant. The time, lost in piecing broken ends and cleaning, varies from 3 per cent on very fine work to as high as 25 per cent on slubber roving.

The number of teeth in the tension and lay gears cannot be figured with absolute certainty as the character of the stock, the amount of twist in the roving and atmospheric conditions affect the winding of the roving.

When the roving is hard twisted, it is smaller in diameter than when soft twisted and does not fill the bobbin as rapidly. This condition demands a tension gear with fewer teeth so the belt will not be shifted so far along the cones or the speed of the spindle be reduced to such an extent as to wind slack roving. The tension gear is a driver and the greater number of teeth it contains the more the speed of the bobbin is reduced at each shift of the cone belt.

The lay gear is also a driver, and, with hard twisted roving, the bobbin should have more coils per inch to be wound correctly. To accomplish this, the rail must be run slower, which requires a smaller number of teeth in the lay gear.

If the rail is not fast enough, the coils of roving will be crowded and overlap each other and a very uneven bobbin will be the result. If the roving winds properly at the beginning of a set, but gets too soft towards the finish, it is evident that a smaller tension gear is needed so that the bobbin will run faster. If, on the other hand, the bobbin becomes too hard, and the roving pulls apart towards the end of a set, it indicates that a larger tension gear is needed to reduce the speed of the bobbin.

On a particularly damp day, the cotton fibers are heavy, and lie closely together, which makes the roving smaller in diameter and in consequence the bobbins do not fill so rapidly. This causes the roving to drag and not take-up, which necessitates a tension gear of one, and sometimes two teeth less, so that the speed of the bobbin shall not decrease so rapidly.

In the practical operation of a mill, when starting up a fly frame to make a certain number of roving, the table of change gears is usually consulted for the correct tension and lay gears, and while two frames may not start up with gears exactly alike, a change of one or two teeth is most always sufficient to produce satisfactory results.

If no table of gearing is available, the following rules will be found useful.

Rule 12. To find the tension gear to make 6 hank roving: (Tension gear on frame 41 teeth. Roving being spun, 3.5 hank.) Find the square root of the present tension gear, squared, multiplied by the present hank, and divide this sum by the required hank.

Example:
$$\sqrt{\frac{41^2 \times 3.5}{6}} = 32.06$$

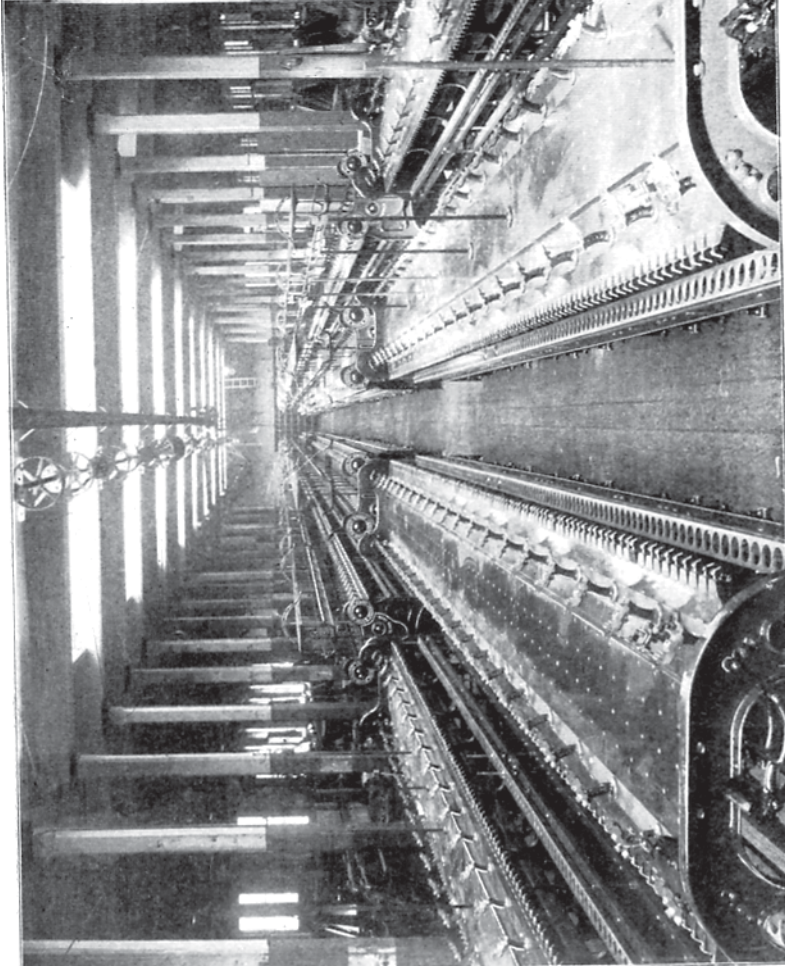

SPINNING FRAME ERECTING DEPARTMENT
Mason Machine Works.

Rule 13. To find the lay gear to make 6 hank roving: (Lay gear on frame, 35 teeth. Hank roving being spun 3.5.) Find the square root of the present lay gear, squared, multiplied by the present hank, and divide this sum by the required hank.

Example:
$$\sqrt{\frac{35^2 \times 3.5}{6}} = 27.31$$

Rule 14. To find the twist gear for 6 hank roving: (Twist gear for 3.5 hank, 40 teeth.) Find the square root of the present twist gear squared, multiplied by present hank, and divide this sum by the required hank.

Example:
$$\sqrt{\frac{40^2 \times 3.5}{6}} = 30.54$$

Rule 15. To find draft gear: (Draft gear, 34 teeth.) Multiply the present hank by the present draft gear and divide this product by the required hank

Example:
$$\frac{3.5 \times 34}{6} = 28.16$$

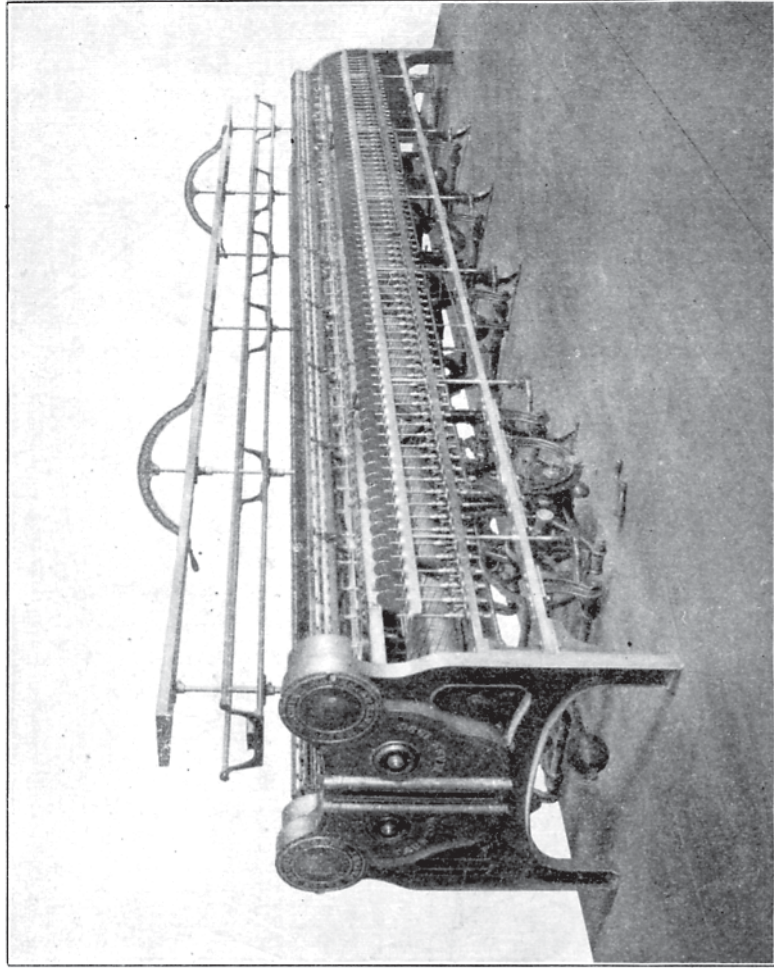

RING SPINNING FRAME
Mason Machine Works.

COTTON SPINNING

PART V

SPINNING

In the final process of forming the cotton into yarn, there are two wholly different types of machines used, the *ring frame* and the *mule*.

The ring frame is used more extensively than the mule, owing to its simplicity and the cost of operating being less. While the ring frame is not adapted for spinning as fine numbers or as soft twisted yarns as the mule, wherever ring-spun yarn can be used with satisfactory results, the ring frame is generally used.

RING SPINNING

The placing of ring frames requires careful consideration. There are two common arrangements. In a mill of a width of one hundred feet or less, the frames should be placed as shown in Fig. 189. This drawing shows a room seventy-five feet wide with two lines of columns, making three spans, each about twenty-five feet wide. Each span will accommodate four lines of ring frames with the proper alleys, which should be from twenty-eight inches to thirty-six inches wide.

There is one main line of shafting from which are driven the countershafts. The frames are offset so that two can be driven from a pulley which has a center flange. Each countershaft carries two pulleys for driving four frames. The head or pulley ends of the frames are about twelve inches apart, which is as close as they can be placed to give ample room for removing the driving pulleys when necessary.

When the room is intended for spinning only, the main line is placed so that it will come between two rows of ring frames, to be best adapted for driving.

When a mill is of sufficient width, the ring frames may be placed crosswise of the room as in Fig. 190. This drawing shows a room

about one hundred twenty-five feet wide with four rows of columns. There are four ring frames in each line, across the room, and a wide alley in the center, extending the length of the room, and also alleys along the side walls. The machines are arranged in pairs with the pulley ends toward each other for convenience in driving.

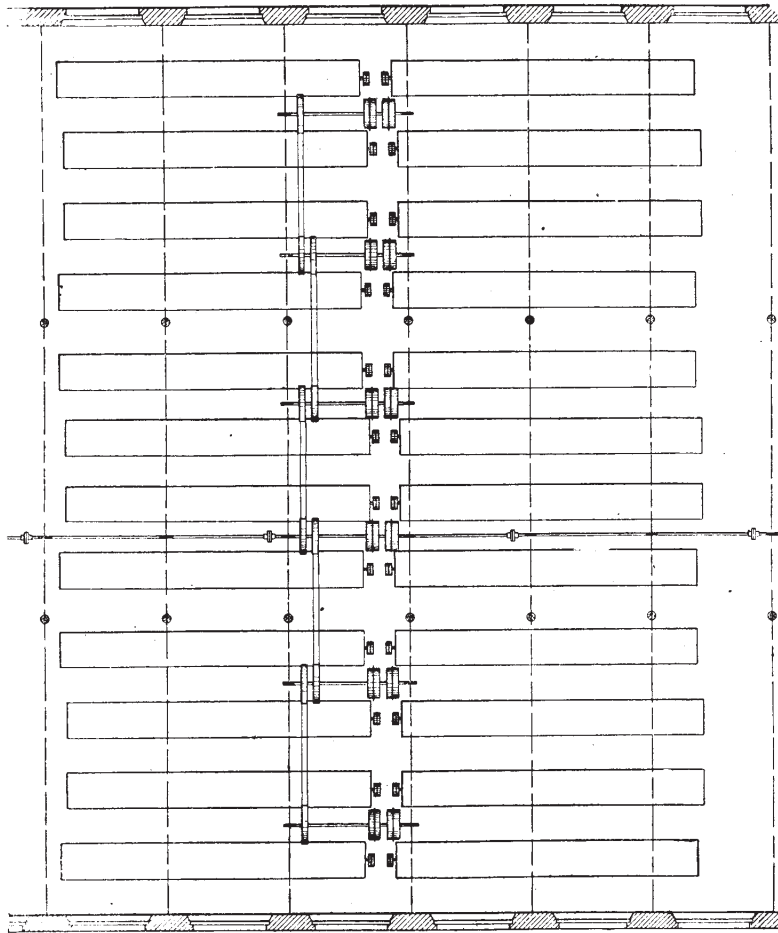

Fig. 139. Plan of Spinning Room with Frames Lengthwise of Room.

There are but two lines of shafting, which extend lengthwise of the room at right angles to the machines, and upon these main lines are the pulleys, each pair of frames being driven from one pulley by the same belt.

A plan and an elevation of a drive of this description are shown

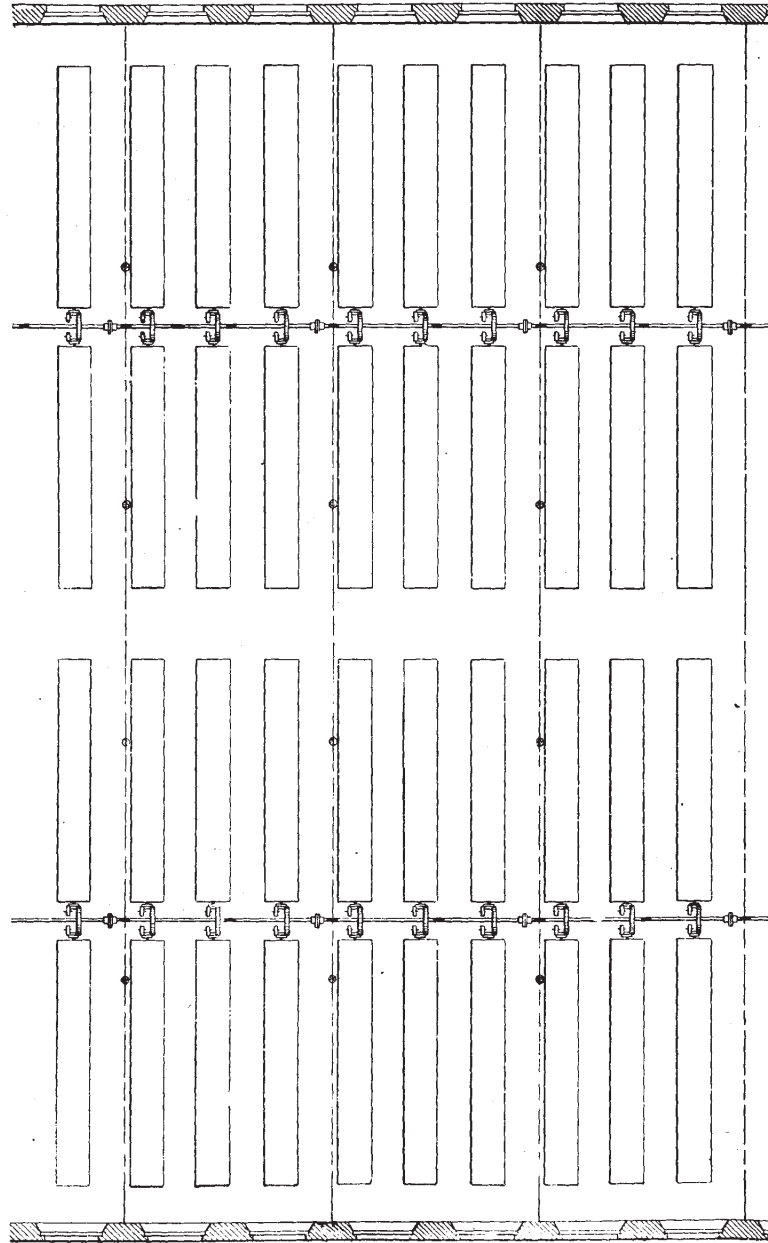

Fig. 190. Plan of Spinning Room with Frames Crosswise of Room.

in Fig. 191. The belt, A, drives downward from the pulley, B, on the line, C, and around the pulley, D, on the frame at the left hand, then upward over the carrier pulleys, E and F, downward around the

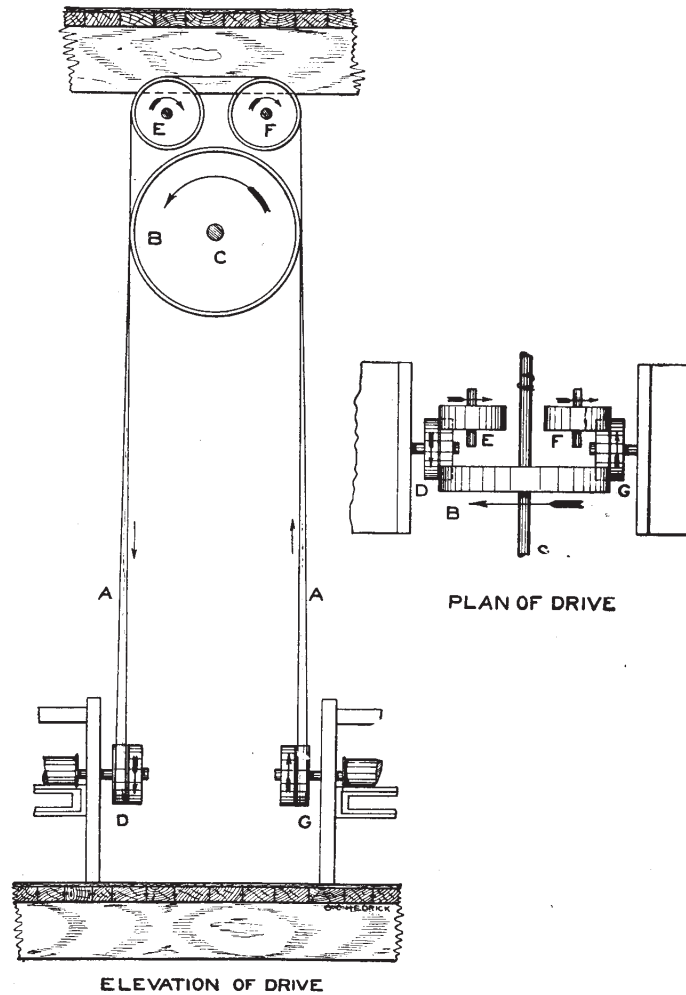

Fig. 191. Pulleys for Drawing Frames Placed at Right Angles to Main Line.

pulley, G, on the frame at the right hand, then up and around the pulley, B.

This method of driving two frames from one pulley makes a very neat and simple drive and saves shafting and belting compared

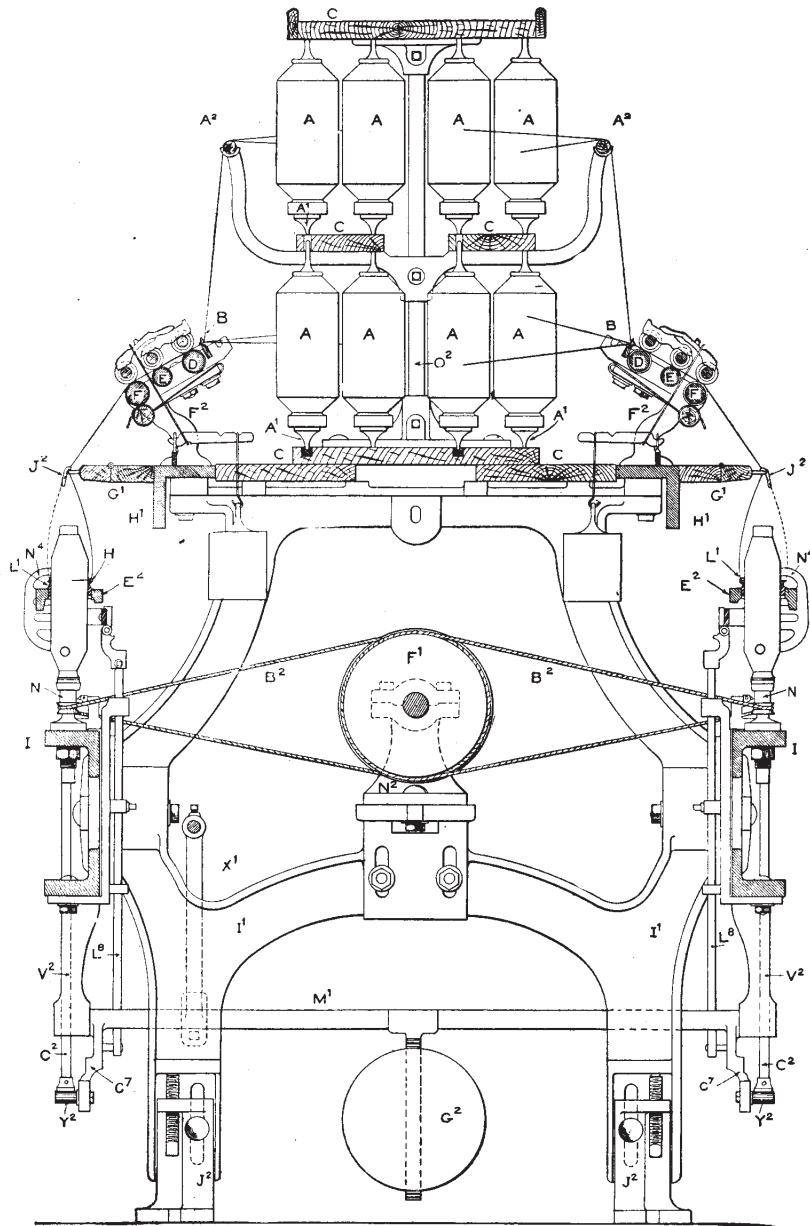

Fig. 192. Sectional Elevation of Ring Frame.

to the arrangement shown in Fig. 189, but the room should be wide enough to place four frames across the room so that an operative can tend at least eight sides.

A sectional elevation of a ring frame is shown in Fig. 192. The various parts of the machine may be referred to briefly as the creel, C, for supporting the bobbins of roving, the roll stands, F², carrying the steel fluted roll, the top rolls, cap bars, trumpet rod, clearers, weights, saddles, etc., thread board, G¹, with the thread guide or "pig tail", J², roller beam, H¹, for supporting the roll stands and

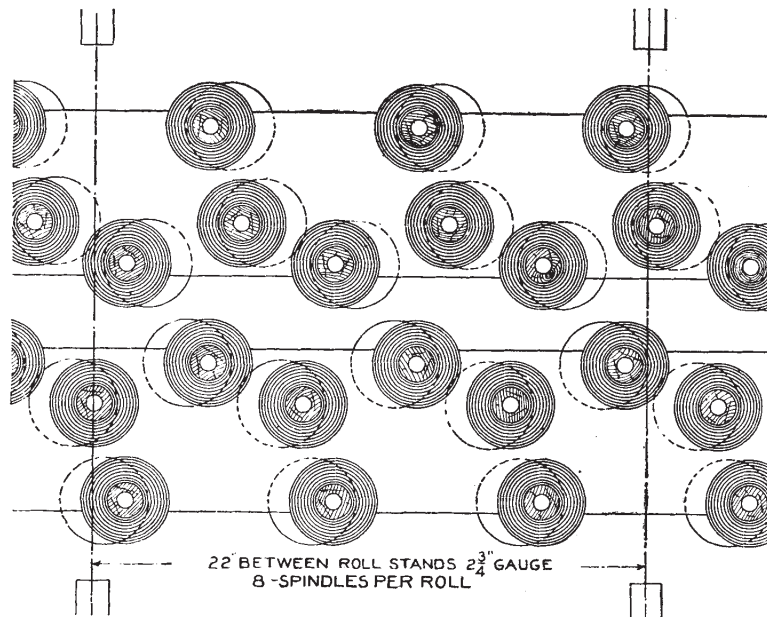

Fig. 193. Plan of Creel for Double Roving.

thread board, the ladder or spindle rail, I, spindle, N, ring rail, E², rings, L¹, drum, F¹, supports, I¹, creel rod, O², cross shafts, M¹, lifting rods, C², separators, N⁴, adjustable feet, J², and drum box, N².

The roving, A, from the top row of bobbins, is drawn over the rod, A², and down to the trumpet, B, while the ends from the lower bobbins draw directly to the trumpet. Both ends pass through the same trumpet, as one end, then between the draft rolls, D, E and F, and down through the thread guide, J², to the ring traveler, H, and are wound finally upon the bobbin, O.

The drum, F^1 , extends the whole length of the frame, and upon one end of it are the driving pulleys. The spindles are driven from the drum by the bands, B^2 , one for each spindle.

The ring rails are fastened to the top of the lifting rod, by which they are traversed up and down for winding the yarn evenly upon the bobbin.

Creels. The Creels are built one or two stories high and for single or double roving. If for single roving, there is only one bobbin

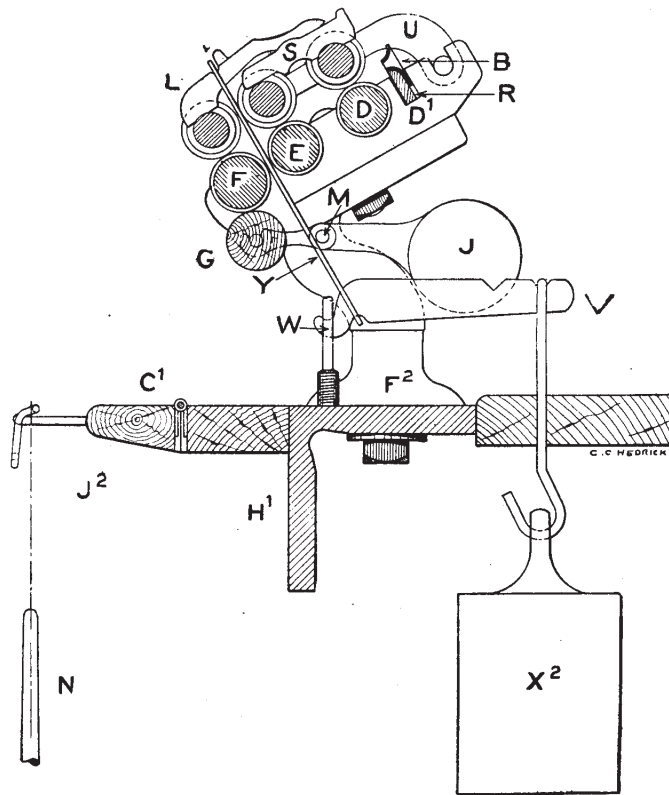

Fig. 194. Elevation Showing Roll Stand and Weighting.

for each spindle and the creel is one story, usually. For double roving, there are two bobbins or ends for each spindle and the creel is two storied.

A plan of a creel for a two and three-quarter inch spaced ring frame, for double roving with bobbins three and one-half inches

in diameter, is shown in Fig. 193 and an elevation is shown in Fig. 192. The creel consists of bottom, middle and top boards. The top board serves for a shelf upon which full bobbins can be placed. The skewers, A¹, for holding the bobbins, A, rest in porcelain steps which

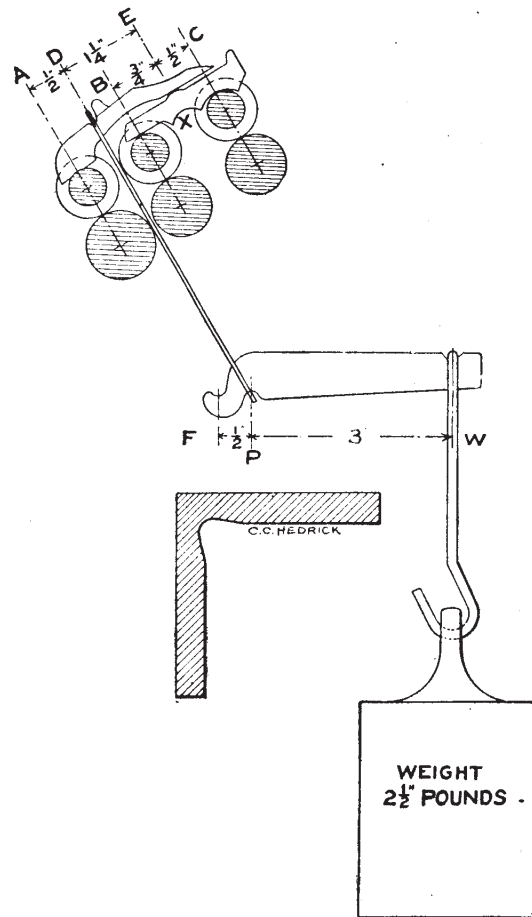

Fig. 195. Diagram of Weighting.

are flush with the boards, forming the creel. The porcelain offers little resistance to the rotation of the bobbins.

The bobbins in the upper tier are shown by full lines and those in the bottom tier by dotted lines. They are so spaced that the back row can be removed without disturbing the front ones, a point which

will be appreciated in a frame of this space and sized creel bobbins.

Roll Stands and Weighting. An elevation of a common roll is shown in Fig. 194. The stand consists of a main piece, F², which carries the front steel fluted roll, F, and a slide, D¹, in which are the bearings for the middle roll, E, and the back roll, D. The slide is adjustable so that the middle roll may be set to the front roll with respect to the length of the cotton staple.

The roving rod, R, carries the brass trumpets, B, through which the roving is drawn, and rests in a slot just behind the back rolls. It is traversed a distance, a little short of the length of the fluted portion of the steel roll, so that the wear will not come on the same part of the boss at all times.

The cap bars, U, for holding the top rolls in place, are pivoted in a slot in the extreme back end of the roll stand slide.

The scavenger, or waste roll, G, upon which the yarn collects when an end breaks, thus preventing a roller lap, is a wooden roll covered with denim or light weight flannel. In each end of the roll are wire gudgeons which rest in open bearings in the scavenger roll weights, J. The weights are pivoted at M and are balanced so that the roll is held, lightly, against the steel front roll.

Sometimes, a spring is used in place of the weights for holding the scavenger roll, as shown in Fig. 192, but this is not as satisfactory as it is apt to break.

The top rolls are both lever-weighted and self-weighted. In the drawing, a system of lever-weighting is shown by which all the rolls receive pressure from one weight.

There are two saddles used; front saddle, L, and back saddle, S. The back saddle rests upon the middle and back top rolls and the front saddle upon the front top roll and the back saddle. The weight, X², is hung from the lever, V, by a weight hook. The fulcrum of the lever is at the lever screw, W, and the stirrup, Y, serves to communicate the pressure from the weight to the front saddle. For single boss rolls, the weight is from two to three pounds and for double boss rolls about six pounds.

A diagram for use in figuring the distribution of weight on the different rolls is shown in Fig. 195.

Front Roll.....	A
Middle Roll.....	B
Back Roll.....	C
Front Saddle.....	D
Back Saddle.....	E
Fulcrum.....	F
Power.....	P
Weight.....	W

To find the weight in pounds upon the front saddle: Multiply the weight (2.5 pounds) by the distance, F-W, and divide by the distance, F-P.

Example:
$$\frac{2.5 \times 3.5}{.5} = 17.5$$

To find the weight in pounds upon the front roll: Multiply the weight upon the front saddle (17.5 pounds) by the distance, E-D, and divide by the distance, E-A.

Example:
$$\frac{17.5 \times 1.25}{1.75} = 12.5$$

To find the weight in pounds upon the back saddle: Subtract the weight upon the front roll from the weight upon the front saddle

Example:
$$17.5 - 12.5 = 5$$

To find the weight in pounds upon the back roll: Multiply the weight upon the back saddle by the distance, E-C, and divide by the distance, B-C.

Example:
$$\frac{5 \times .75}{1.25} = 3$$

To find the weight in pounds upon the middle roll: Subtract the weight upon the back roll from the weight upon the back saddle.

Example:
$$5 - 3 = 2$$

Sometimes, it is desired to run the frame with no weight upon the middle roll. Then, the saddle is pushed back until the curved part, X, comes over the neck of the back roll arbor. This removes the flat part of the saddle from the middle roll and the weight is borne by the front and back rolls.

Roll stands are made with the rolls inclined from a horizontal line at various angles from twenty-five to thirty-five degrees. For spinning warp and other hard twisted yarns, the twenty-five degree pitched stand, shown in Fig. 196, is largely used. For ring frames to be used for spinning both warp and filling yarn, the thirty degree pitched stand, shown in Fig. 197, is sometimes used. While for

filling yarn and any soft twisted yarn, the thirty-five degree pitched stand, shown in Fig. 198, is often used.

The reason for inclining the rolls is very simple. As the yarn leaves the bite of the front roll, it is important that it shall receive twist at once, as the high speed that the spindles run and the tension upon the yarn due to drawing the traveler around the ring, tend to break the yarn. If the yarn, after leaving the bite of the roll, is caused to draw around a portion of its circumference, the twist will not readily pass this point of contact and the yarn, between this point of contact and the bite of the roll, receives little or no twist. The roll stands, therefore, are inclined enough to allow the twist to run nearly to the bite of the front roll. This is particularly necessary when spinning filling yarn, which has less twist than warp yarn, and not only are the stands inclined at a great angle, but sometimes, the front roll is set nearer over the spindles so that the yarn shall draw more nearly in a straight line from the front roll to the traveler.

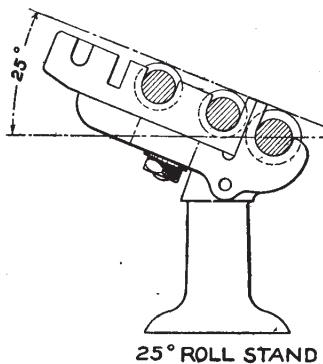

25° ROLL STAND

Fig. 196. Warp Roll Stand,
25° Pitch.

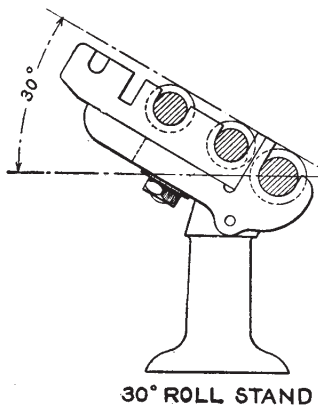

30° ROLL STAND

Fig. 197. Combination Roll Stand,
30° Pitch.

A roll stand of this type is shown in Fig. 199. The center of the spindle is about four and one-quarter inches from the face of the roller beam, and the center of the front roll is about midway of this space.

Self-Weighted Top Rolls. Ring frames, for spinning long staple cotton, are frequently provided with self-weighted top rolls for the middle and back lines. A frame with rolls of this kind is shown in sectional elevation in Fig. 200.

The front top roll, B, which is a shell roll one and three-eighths inches in diameter, is weighted by a weight, G, which extends from

side to side of the frame and is connected to the top rolls by hooks, F, and stirrups, E. Holes are drilled in the roller beams to allow the hooks to connect with the stirrups. The hook shaped projection on the top of the stirrups is to allow the operative to lift the weight clear of the top roll, when necessary, and the round eye, formed on the top of the hook, prevents the weight from dropping down upon the drum when the top roll is removed, as the eye is larger in diameter than the hole in the roller beam and can not pull through.

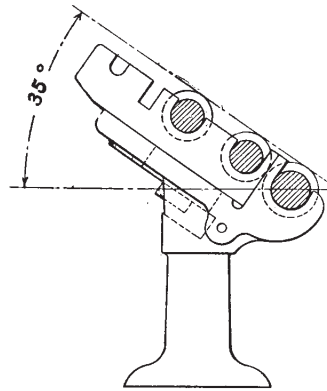

35° ROLL STAND

Fig. 198. Filling Roll Stand,
35° Pitch.

The top roll for the back line is one and three-quarters inches in diameter and for the middle line is three-quarters of an inch in diameter. The rolls are made of cast iron and are not covered with leather, a saving in repairs.

The top clearer is conical and is the same as those used on fly frames with self-weighted top rolls, as shown and described in a previous chapter.

Sometimes, a double cone clearer is used with a device at each end of the frame that tips the clearer, automatically, when it reaches the end, allowing it to work back.

In addition to the usual front scavenger roll, a second roll is sometimes used which bears against the underside of the middle and back steel rolls. It is one inch in diameter, covered with denim, and supported by springs held in sockets. The arrangement is such as to allow the rolls to be easily detached for cleaning.

The middle and back rolls are carried by the same slide and are set about one and three-fourths inches between centers. The adjustment is between the front and middle rolls.

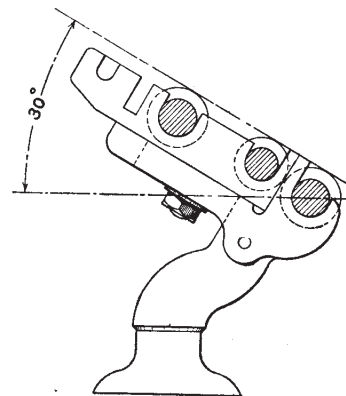

30° ROLL STAND

Fig. 199. Roll Stand, 30° Pitch, for
Overhanging Front Rolls.

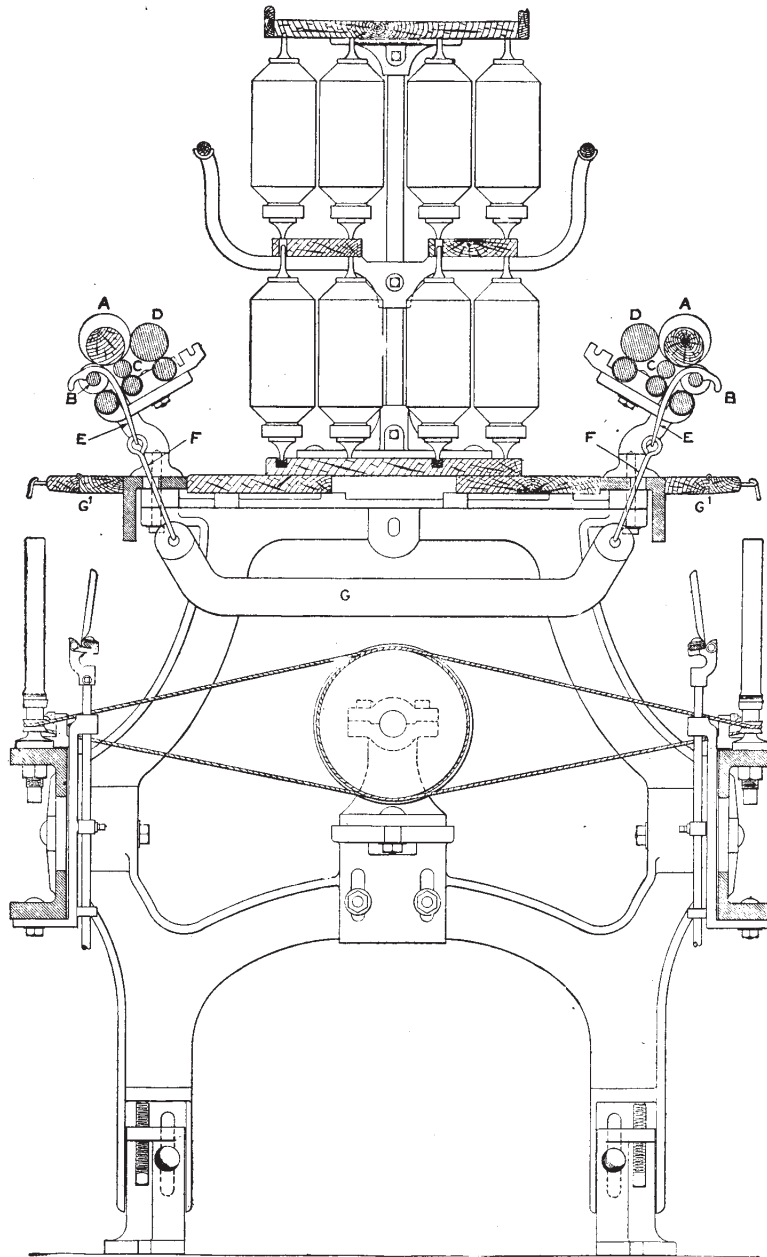

Fig. 200. Sectional Elevation of Ring Frame with Self-Weighted Top Rolls.

In setting a frame with self-weighted top rolls, it is the practice to "set on the staple," which means to make the distance between the centers of the front and middle rolls a trifle less (one-sixteenth to one-eighth of an inch) than the length of the cotton staple. This is just opposite to the method of setting weighted rolls, which are set from one-sixteenth to one-eighth more on centers than the length of the staple.

It is frequently argued that no great range in counts can be spun with self-weighted rolls, as the weight of a roll, correct for spinning 10's yarn is not right for 30's. This is, however, a mistake as from 10's to 80's can be spun with rolls of the sizes mentioned.

Thread Boards. The thread boards for supporting the thread guides are made of wood or metal. Figures 192 and 200 show a common wooden thread board, G¹, consisting of a doffing strip, which is secured to the roller beam by hinged brackets, and blocks for holding the thread guides, which are hinged, to the thread board. The thread guide is made with various shaped eyes and is screwed into the block.

The metallic thread board is made of thin sheet metal, nickel plated and secured to the roller beam similarly to the wooden one.

Metallic boards are considered to be an improvement over wooden ones, as there is an adjustment for the thread guide in all directions in a horizontal plane, and the eye of the guide may be very easily set in the correct position over the spindle. With the wooden thread board, the eye can be adjusted only by screwing it in or out of the block, and for any side movement, the only way is to bend the guide to meet the spindle. This is apt to loosen the guide and cause it to work out.

A large per cent of broken ends is caused by faulty setting of the thread guides, a point which should not be overlooked. In setting the guide, it is customary to put a round, wooden piece called a "set" on the spindle. This is made with a pin in the top. The length of the set is such as to bring the pin up just under the thread guide. The guide is then set so that the thread will draw from the back side of the eye to the center of the spindle.

Spindles. A type of spindle, commonly used on modern ring frames, is shown in Fig. 201. It consists of a base, bolster, step, spindle blade, whirl and cup.

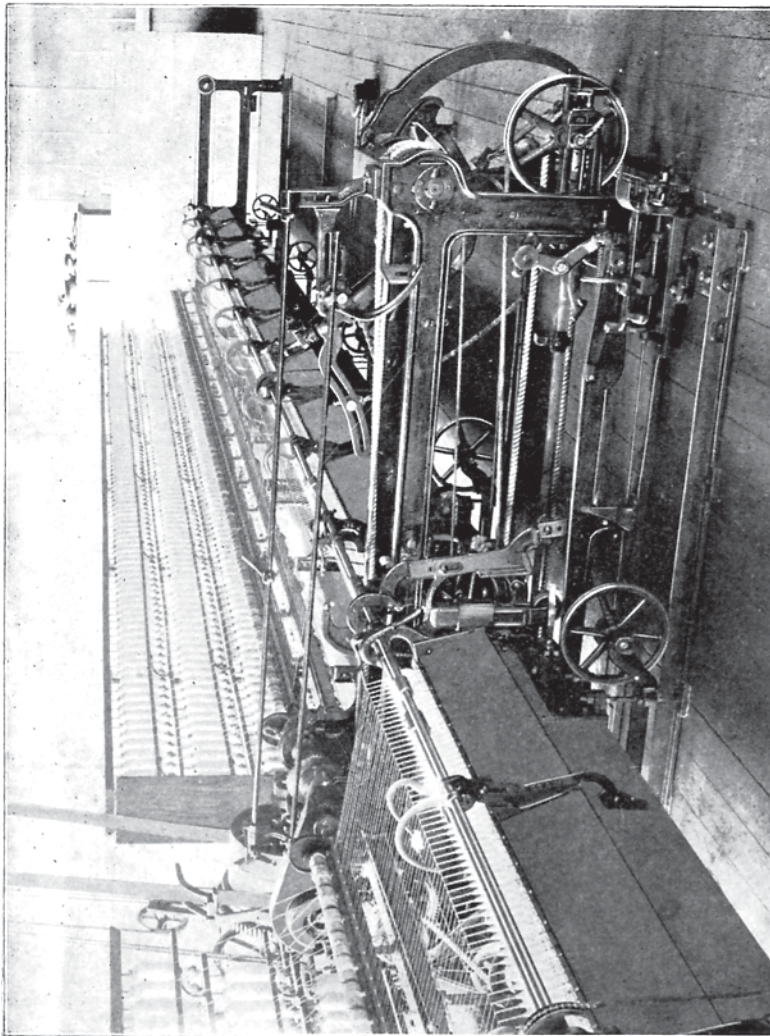

MASON SELF-ACTING MULE WITH ROPE DRIVEN CARRIAGE
Mason Machine Works.

The whirl is driven on to the spindle, and the cup, which helps center and rotate the bobbin, is forced on to the sleeve of the whirl. The lower part of the bolster is covered with packing, tied with a fine string. This gives greater steadiness to the running of the spindle and better wearing qualities.

The step is made of hardened steel, has a flat top, and is screwed into the bottom of the bolster.

The base is made with an upward projecting nose, or oil tube,

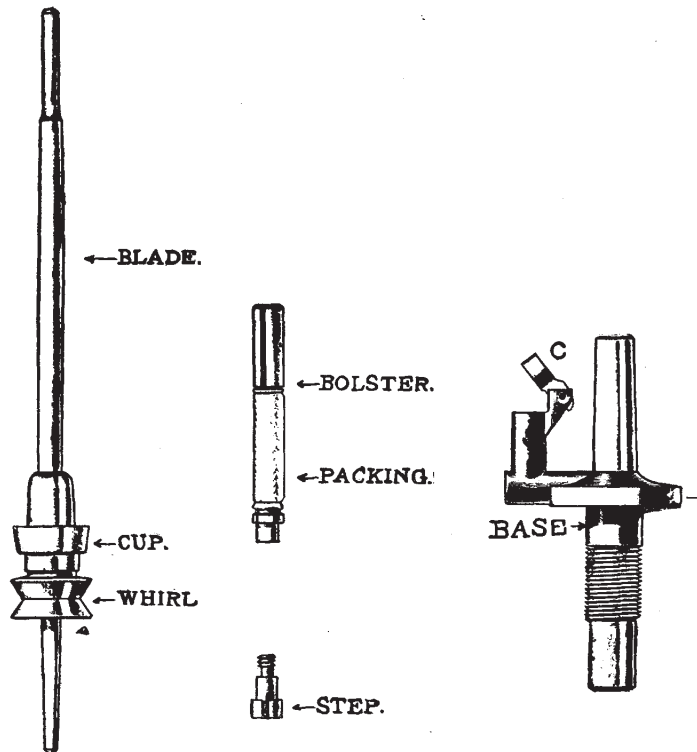

Fig. 201. Spindle Parts.

S, the cover, C, of which forms a lock to prevent pulling the spindle out of the bolster when doffing. The stem of the bolster is threaded to receive a nut for securing the base to the spindle rail.

The cups are usually of brass and are made several sizes to suit the different sized bobbins. They are called warp cups and filling cups. Many prefer to have the cups all one size, particularly

when frames are to be run for both warp and filling, so that the bobbins will be interchangeable.

Fig. 202 shows a spindle and bolster assembled.

Separators. Separators are usually applied to frames for spinning warp yarn and, sometimes, to those for filling yarn, as the high speed of the spindles, and the long traverse of modern frames, cause the ends to whip and break down.

The separator blades, N^4 , (Fig. 192) are thin, steel plates, of a size to suit the length of traverse, and are mounted upon light rods which extend parallelly with the ring rails. They are connected with the traverse motion from the cross shaft arm, M^1 , by the rods, L^8 , so they rise and fall with the ring rail, and are arranged so that they can be tipped back out of the way while doffing. The blades are placed midway of the spaces between the center of the spindles, and the ballooning yarns are kept from whipping together.

This ballooning is very apparent on warp frames, when the rail is at the bottom of the traverse, as there is considerable length of yarn between the thread guide and the traveler.

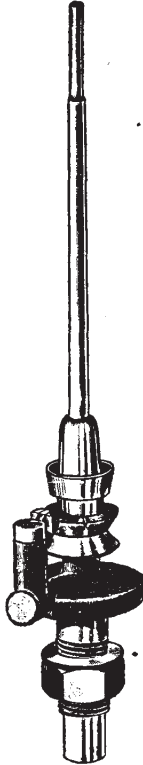

Fig. 202. Spindle Assembled.

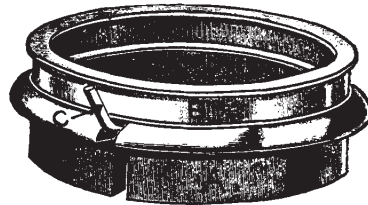

Fig. 203. Double Ring in Cast Iron Holder.

Spinning Rings. Rings that are supplied with new ring frames are usually double rings, set in either cast iron or plate holders. The ring shown in Fig. 203 is such, in a cast iron holder with wire traveler cleaner; A, is the holder, B, the ring, and, C, the cleaner. A recess is formed on the inside of the holder and the traveler cleaner lies around the recess, between the ring and holder.

The position of the upturned end of the traveler cleaner is such that, as the traveler rotates, the loose fibers and fly, which are always

floating about a spinning room, and which are bound to gather on the traveler, are wiped off and the traveler kept clean. Unless the traveler is kept free from this accumulation, uneven yarn will be caused.

The traveler cleaner is set just far enough away so that it cannot interfere with the rotation of the traveler. It cannot get out of place, because the tail is always set concentric with the ring.

Another style of "double ring", in a plate holder, is shown in Fig. 204. This is known as a double adjustable ring. It is in a plate holder with part of the plate turned up to form the traveler cleaner. A, is the ring, B, the plate holder, and, C, is the part of the plate which forms the traveler cleaner.



Fig. 204. Double Ring in Plate Holder.

The advantage claimed for a double ring, is, that when the top flange becomes worn, it may be reversed in the holder, the other side used, prolonging very much the wear of the ring.

The plate holders are made round, oval or square. A round holder is shown, with the ring, in Fig. 204, and an oval plate holder with a double ring is shown in Fig. 205.

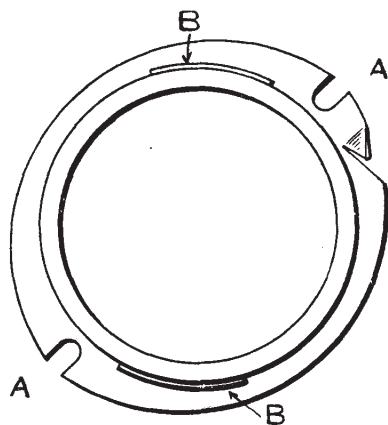

Fig. 205. Oval Plate Holder and Ring.

The oval holder has two screw slots at AA, for securing the holder to the ring rail, and two lugs at BB for fastening the ring to the holder. The slots permit the holder to be adjusted so the ring can be set concentric with the spindle.

A square holder is shown in Fig. 206. This one has also two slots, AA, for fastening it to the rail but has three lugs, BBB, for fastening the ring to the holder.

The cast iron holder is secured to the ring rail by three screws, two in front and one in the rear of the ring, and, by loosening one and

tightening the other two, the ring can be moved a slight distance for setting it in position. The cast iron holder is made with a split so that it can be sprung open, slightly, to remove the ring.

Rings, known as solid rings are also used. They are without holders and are made to fit the holes in the ring rail with a very slight adjustment by screws the same as the cast iron holders.

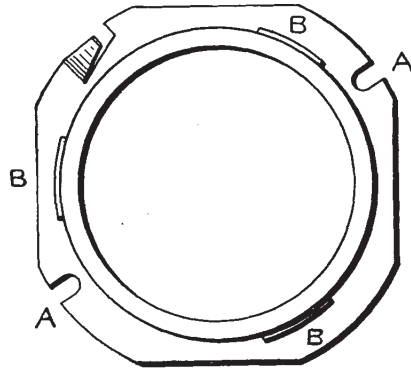

Fig. 206. Square Plate Holder and Ring.

Rings are often specified as one and one-half inch ring in a holder for one and three-fourths inch ring. This permits the holder to be removed and a one and three-fourths inch ring and holder to be used in the same place. The

hole in the ring rail is made large enough that a one and three-fourths inch ring may be used.

The flanges for the rings for ring frames are known as numbers 1, 2, etc. Number 1 flange is one-quarter of an inch wide, and is usually used for rings up to one and three-fourths inches in diameter, while number 2 flange, which is five thirty-seconds of an inch wide, is used for sizes up to two and one-fourth inches in diameter. This is not an absolute rule to follow but is recommended by some of the prominent ring makers.

Enlarged sections of flanges, numbers one and two with the respective sizes of the traveler, are shown in Fig. 207.

Ring Travelers. There is no rule by which the correct weight of travelers may be determined for a certain number of yarn, as the size of ring, speed of spindle, number of yarn and twist per inch, introduce elements which affect the size of the traveler, and, also, the different makes of travelers vary slightly in the numbers of different sizes.

The following table gives approximately the correct size of ring

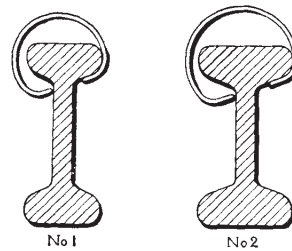

Fig. 207. Enlarged Section of Flange of Rings and Travelers.

travelers to use for spinning yarns of ordinary twist and of various sizes of rings. This table is given as a guide to select travelers, but it must be understood that the numbers will vary somewhat owing to circumstances as referred to above.

No. Yarn	1½" Ring	1⅝" Ring	1¾" Ring	No. Yarn	1½" Ring	1⅝" Ring	1¾" Ring
8	10	9	8	30	8 0	4 0	5 0
10	8	7	6	32	4 0	5 0	6 0
12	7	6	5	34	5 0	6 0	7 0
14	6	5	4	36	6 0	7 0	8 0
16	5	4	3	38	7 0	8 0	9 0
18	4	3	2	40	8 0	9 0	10 0
20	3	2	1	42	9 0	10 0	
22	2	1	1 0	44	10 0	11 0	
24	1	1 0	2 0	46	11 0	12 0	
26	2 0	3 0	4 0	48	12 0	13 0	
28	3 0	4 0	5 0	50	13 0	14 0	

Principle of the Traveler. The traveler receives its motion by being dragged, by the yarn, around the ring, and, in the passage of the yarn from the front roll to the bobbin, it is turned at a right angle at the point where it passes through the traveler. Therefore, all of the twist is introduced between the traveler and the front roll. In fact, the traveler performs a double duty, giving the twist to the yarn and guiding it on to the bobbin.

The size and weight of the traveler must be adapted to the number of yarn being spun. This is necessary so that the revolutions of the traveler shall fall behind the revolutions of the bobbin enough to maintain a tension upon the yarn, sufficient to wind the same length, that is delivered by the front roll, less a small amount due to contraction in consequence of the twist.

The smaller the diameter of the bobbin, the more revolutions are necessary to wind the same length, and, as the speed of the bobbin is constant, it is evident that the tension upon the yarn must relax and

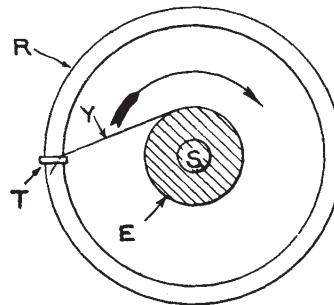

Fig. 208. Diagram Showing Principle of Traveler.

allow the traveler to fall behind the bobbin and cause more yarn to be wound. This may be understood by noting the two diagrams, Figs. 208 and 209. In these illustrations, R is the ring, T, the traveler, S, the spindle, F, the full bobbin, and E, the empty bobbin. The yarn is represented, as passing through the traveler, by the line Y.

With the full bobbin (Fig. 209), the pull of the yarn is nearly parallel with the ring, and the traveler is rotated with comparative ease, but with the empty bobbin (Fig. 208), the pull of the yarn approaches a radial line and is not as well suited to rotate the traveler.

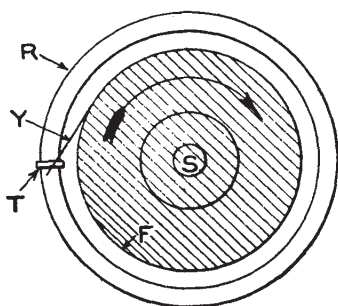

Fig. 209. Diagram Showing Principle of Traveler.

We will assume that the empty bobbin is three-quarters of an inch in diameter (2.35 inches circumference) and the full bobbin is one and three-quarters inches in diameter (5.49 inches in circumference). If the traveler is held stationary and the empty bobbin given one revolution, there will be wound 2.35 inches of yarn, while with the full

bobbin, one revolution will wind 5.49 inches.

If the rotations of the traveler were not retarded, it would travel around the ring a distance equal to 2.35 inches, for an empty bobbin and 5.49 inches for a full bobbin, and, as each rotation of the traveler gives one twist to the yarn, a considerable difference in the twist per inch will be produced, but as the traveler falls behind the bobbin only enough to cause the yarn to be wound, the difference in the twist is not appreciable.

If the bobbin makes one hundred revolutions and in the same time the front roll delivers ten inches of yarn, the twist can be called ten per inch.

The empty bobbin will have to make 4.25 revolutions.

$$\frac{10}{2.35} = 4.25$$

The traveler will make 95.75 rotations, or the speed of the bobbin less the number of revolutions, necessary to wind the yarn.

$$100 - 4.25 = 95.75$$

At each rotation of the traveler, the yarn receives one twist, so the *actual* twist per inch will be 9.57.

With the full bobbin, 1.84 revolutions are necessary to wind the ten inches of yarn, delivered by the front roll.

$$\frac{10}{5.49} = 1.84$$

The traveler will then make only 98.16 rotations.

$$100 - 1.84 = 98.16$$

The difference in twist per inch between a full bobbin, one and three-fourths inches in diameter and an empty one, three-fourths of an inch in diameter, is the difference between 9.81 and 9.57 or .24 of one turn in a length of ten inches.

Builders. There are three kinds of builders used upon the ring frame. The warp builder is shown in Fig. 210, the filling builder in

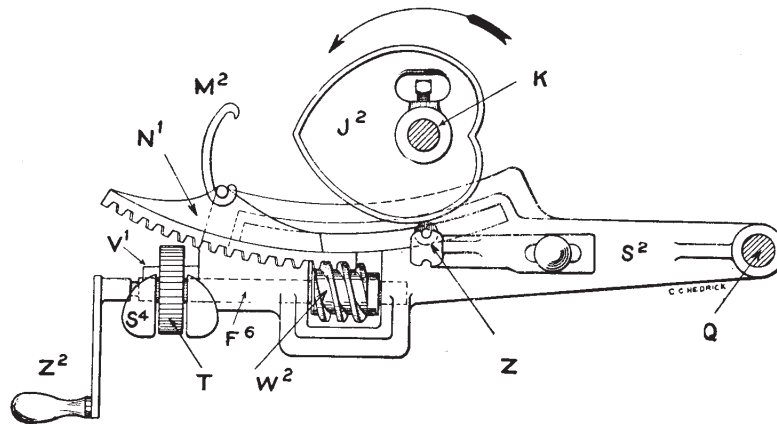

Fig. 210. Warp Builder.

Fig. 213 and the combination builder, which can be changed for either warp or filling wind, in Fig. 215.

With the warp builder, the yarn is wound the whole length of the bobbin at first and the length of the traverse is gradually shortened at each end as the bobbin increases in diameter, as shown by the distance A-B, Fig. 211.

The warp builder consists of a main piece or arm, S², rack, N¹, hook, M², worm, W², worm shaft, F⁶, ratchet gear, T, pawl, V¹, counterbalance weight, S⁴, and roll, Z. All these parts are mounted upon the builder arm which is hung upon a stud at Q. The worm is

fastened to one end of the worm shaft, and engages the teeth of the rack, and the ratchet is fastened to the other end of the shaft and its teeth are acted upon by the pawl.

The means for producing the up and down movement of the rail is by a uniform motion cam, J^2 , which bears against the cam

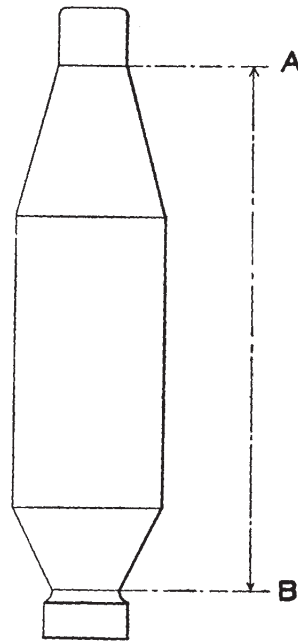

Fig. 211. Warp Bobbin.

roll and this motion is communicated to the ring rail by a chain from the hook fastened to the builder rack.

The connection from the chain to the ring rail is shown in perspective in the drawing Fig. 212. The cross shafts, M^1 , by which the guide rods are operated, are supported in hangers, V^2 , which are bolted to the underside of the ladders. An upward projecting arm, X^1 , carries a swivel to which is connected the builder chain, Y^1 , and a horizontal arm, C^7 , carries a roll, Y^2 , which bears against a shoe on the lower end of the guide rod, C^2 . The ring rails, E^2 , rest upon brackets on the top of the guide rods. A counterbalance weight, not shown in the drawing but attached to each cross shaft and shown as G^2 in Fig. 192, keeps the builder cam roll up against the cam, so that there shall be no backlash at the end of the traverse.

The cam is fastened to the cam or heart shaft, K , which is driven from the foot or gear end, P^1 , to which reference will be made later.

The rack is shown wound out to the extreme end of the arm, and the ring rail moves the full length of its traverse, but at each upward swing of the arm, the pawl is brought into contact with the dagger, E^2 , which is fastened to the ladder. This gives the ratchet gear a partial turn, and the rack is drawn back toward the fulcrum of the arm and the traverse of the rail is shortened.

The ratchet gears are made with various numbers of teeth and the dagger is adjustable so that it can be set to take up more or less teeth.

When the bobbin is full, the rack is wound out to commence a new set by the crank, Z^2 , called the builder key.

The filling builder (Fig. 213) is connected to the ring rail in the same manner as the one just described, but with the filling wind, the rail starts at the lowest point in the traverse and, instead of winding

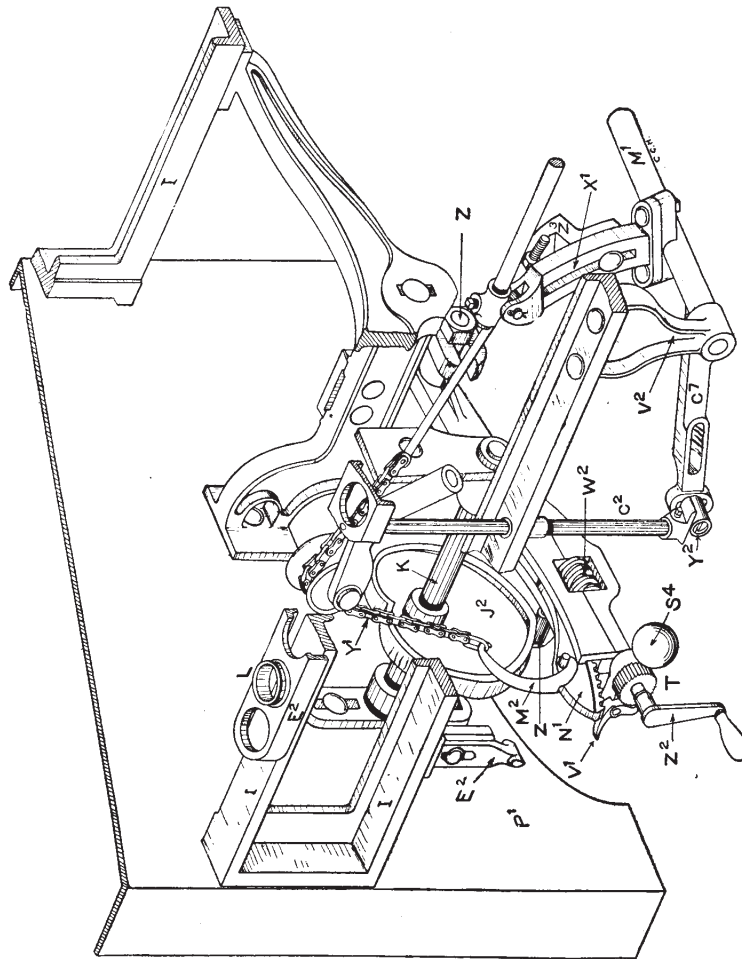

Fig. 212. Perspective View Showing Connection from Builder to Ring Rail.

the yarn the whole length of the bobbin, it is wound a short distance, as shown by A-B in Fig. 214. The length of the traverse remains the same throughout the whole length of the bobbin, but its position gradually goes higher until it reaches the top of the bobbin. This

is accomplished in the following way: The worm, W^2 , instead of engaging a rack as on the warp builder, is in gear with a worm gear, V^2 , the hub of which is made as a drum upon which the builder chain, T^5 , is wound. The ratchet gear is turned in the same manner as for the warp builder.

At the beginning of the set, when the rail is at its lowest position, the chain is wound around the drum, but as the ratchet gear is slowly

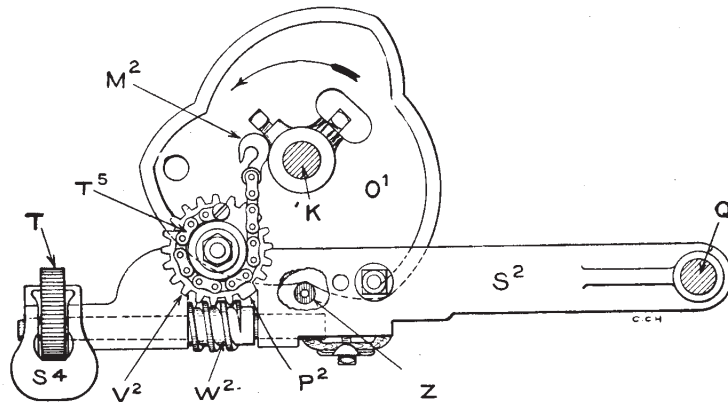

Fig. 213. Filling Builder.

turned, it is gradually unwound and the traverse is allowed to go higher on the bobbin. The builder is wound back with a key, the same as the warp builder.

The filling cam, O^1 , is made with three lobes, so each revolution of the cam shaft causes the ring rail to make three complete traverses against one complete traverse of the warp cam. Owing to the peculiar outlines of the filling cam, the rail is made to traverse in one direction faster than in the other. The cam can be put on to the cam shaft so as to give either a fast or slow down traverse to the ring rail. The slow down traverse is generally preferred, as the yarn draws off the bobbin much better and with less danger of breaking when afterwards used in the shuttle in weaving.

The object in having the rail run faster one way than the other is to permit the coils, wound on the slow traverse, to be covered by the coils of the fast traverse which wind more openly and this, in a measure, prevents the yarn from becoming tangled, and allows it to unwind from the bobbin more freely.

The combination builder (Fig. 215) may be used for either a warp, or a filling wind, by making a slight change in the arrangement of parts, but it is necessary to use both warp and filling cams to produce this change.

The drawing shows the builder arranged for a filling wind. The chain is fastened to the hook, formed in the end of the filling arm, K^1 , which is pivoted on the builder at Z^1 . Upon commencing to spin a set, the builder is drawn out until the roll, J^1 , which is fastened to the rack, N^1 , is brought against the neck of the filling arm in the position shown.

The builder arm is caused to traverse by the filling cam, O^1 , in the same manner as the other builders, and the rack is gradually moved back towards the fulcrum of the builder arm, carrying with it the roll. This movement allows the filling arm to rise and the traverse of the rail to approach the top of the bobbin. The length of the traverse remains the same, as the position of the point, to which the chain is attached to the filling arm, is not changed.

When the builder is to be changed from filling to warp, the filling cam is loosened and slipped along the shaft, and the warp cam is put in its place; the chain is then unhooked from the filling arm and fastened to the pin in the rack.

In setting the warp builder shown in Fig. 210, the rack, N^1 , is first drawn out, as shown in the drawing, and the traverse is set by running the ring rail down, to bring the traveler to the position wanted on the bobbin. The rail is then raised to the desired point, and by adjusting the length of the chain arm, Z^3 (Fig. 212), the exact length of the traverse can be determined.

The length of taper, for the top or bottom of the bobbin, can be varied by raising or lowering the fulcrum, Q , of the builder arm. This may be understood by reference to Fig. 216. The builder is set for the same length of taper for both ends of the bobbin. The

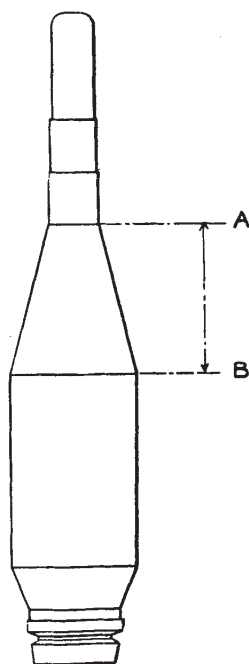

Fig. 214. Filling Bobbin.

fulcrum of the builder arm is at Q; the throw of the cam is shown by the distance between the center of the cam rolls, A and B.

When the rail is traversing its greatest distance and the rack is wound out, the hook is at G and the length of the traverse is repre-

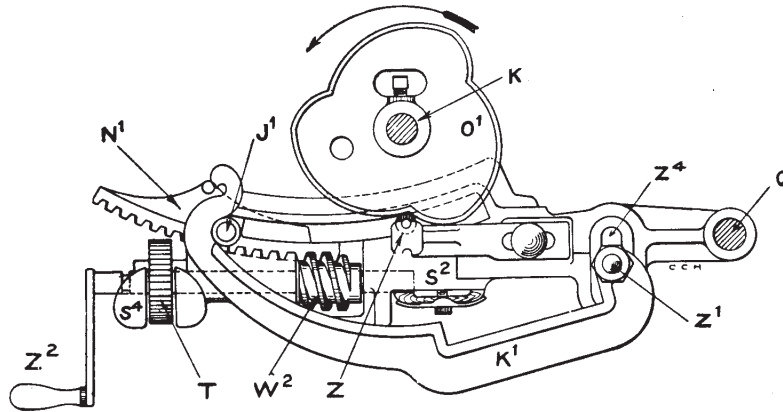

Fig. 215. Combination Builder.

sented by the distance between the horizontal lines, C-D. But when the bobbin is full and the traverse is shortened to its extent, the point, G, where the hook is attached, has moved in to H and the traverse of the rail is represented by the distance E-F. The distance between

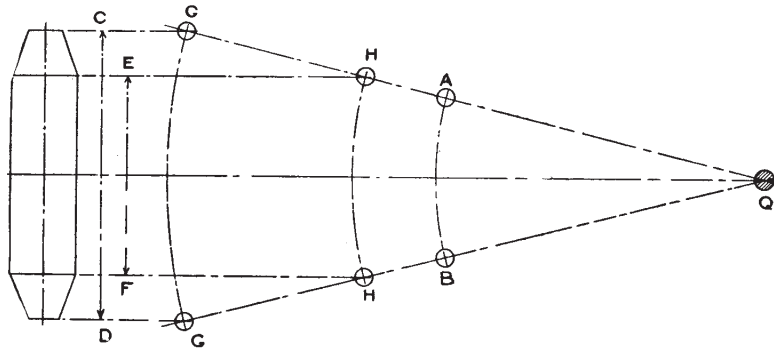

Fig. 216. Diagram Showing Taper at Top and Bottom of Bobbin.

C-E and F-D is the same and the bobbin has the same amount of taper at each end.

If it is desired to have a long taper upon the top of the bobbin, the fulcrum of the builder arm is dropped, as in Fig. 217, which

results in making a long nose on the top of the bobbin. The greatest traverse of the rail is represented by the distance, C-D, and the shortest traverse by the distance, E-F. Unlike the previous drawing, the distance between the horizontal lines, D-F, which represents the lowest position of the rail for both the long and the short traverse, is much less than the distance, C-D.

If the long taper is wanted upon the bottom of the bobbin, the fulcrum is raised. The length of the taper can be regulated to a certain extent by raising or lowering the dagger so as to let off a greater or lesser number of teeth.

In starting the filling builder, the chain should be wound up as shown in the drawing (Fig. 213) until the double tooth, P², comes around against the worm, which forms a stop, so that the rail shall

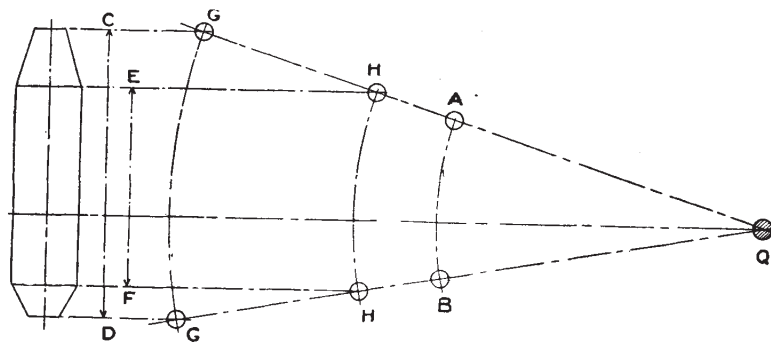

Fig. 217. Diagram Showing Taper at Top and Bottom of Bobbin.

start in the same position each time. The length of taper may then be regulated by raising or lowering the fulcrum of the builder arm and also by letting off teeth on the ratchet gear.

In using the combination builder, for a filling wind, the fulcrum of the filling arm is raised or lowered in the slot, Z⁴, instead of raising the fulcrum, Q, of the arm.

A word in regard to the respective merits of stick doffing and twist doffing. The method, employed by most of the mills, throughout the country, where modern spindles are used, is "stick" doffing. This is done by running the ring rail to the lowest point in its traverse, and winding a few coils of loose yarn around the cup, so that when the full bobbin is drawn off, this loose yarn will wind closely around

the blade of the spindle. The empty bobbin is then pushed down on the spindle, and the loose yarn is caught between the spindle and the bobbin, so when the frame is started, the yarn is ready to wind on.

The system, called "twist" doffing, is used where old style spindles are used. This method consists in stopping the frame about in the middle of the extreme ends of the traverse on both warp and filling frames. When the full bobbin is removed, the empty one is twisted around the loose yarn and pushed down on the spindle. When the frame is started, a slight ridge is sometimes formed before the rail begins to traverse. This is a serious fault, on a filling wind, for as the yarn grows less on the bobbin and begins to draw from a point below the ridge, it breaks, causing frequent stopping of the loom when weaving.

The "stick" method cannot be used successfully, on the old style spindles, as the yarn cannot be wound around the base of the blade without seriously interfering with the putting on of the empty bobbins.

The "twist" doff takes considerably longer than the "stick" doff, and for that reason, the latter is used whenever possible.

Gearing. An elevation, showing the gear end of a ring frame, is shown in Fig. 218. The front rolls, F, are driven from the drum shaft, G⁶, by the drum gear, A⁴, the stud gear, C⁶, the twist gear, K⁶, intermediate gears, N⁶, and the front roll gear, S⁴.

The cam shaft, K, is driven from the sprocket gear, J⁴, on the hub of the intermediate gear, N⁶, by a chain, A⁴, a sprocket gear, D⁶, the bevel gears, E⁶ and F⁶, the worm, W⁶, and the worm gear, J⁷, which is upon the cam shaft.

The draft gearing is shown on the right hand side of the frame. The gear, A, on the front roll drives the crown gear, M⁶, and on the stud with the crown gear is the draft gear, D⁶, which drives the gear, K⁶, on the back roll. The gear, O⁶, on the back roll drives the middle roll through the carrier gear, P⁶ and middle roll gear, R⁶. The draft gearing is alike on each side of the frame and for extremely long frames a set of draft gears is used upon each end; "*double geared*", it is called.

The arrangement of the twist gearing is such that a combination of gears may be applied that will give a wide range of twist.

The drum and stud gears are of twenty-four and ninety-one

teeth. These can be changed to thirty and eighty-five or forty and seventy-five teeth.

The twist gear, which has from twenty to fifty teeth, is carried by a link, A', which swings on the hub of the drum box, and, as shown

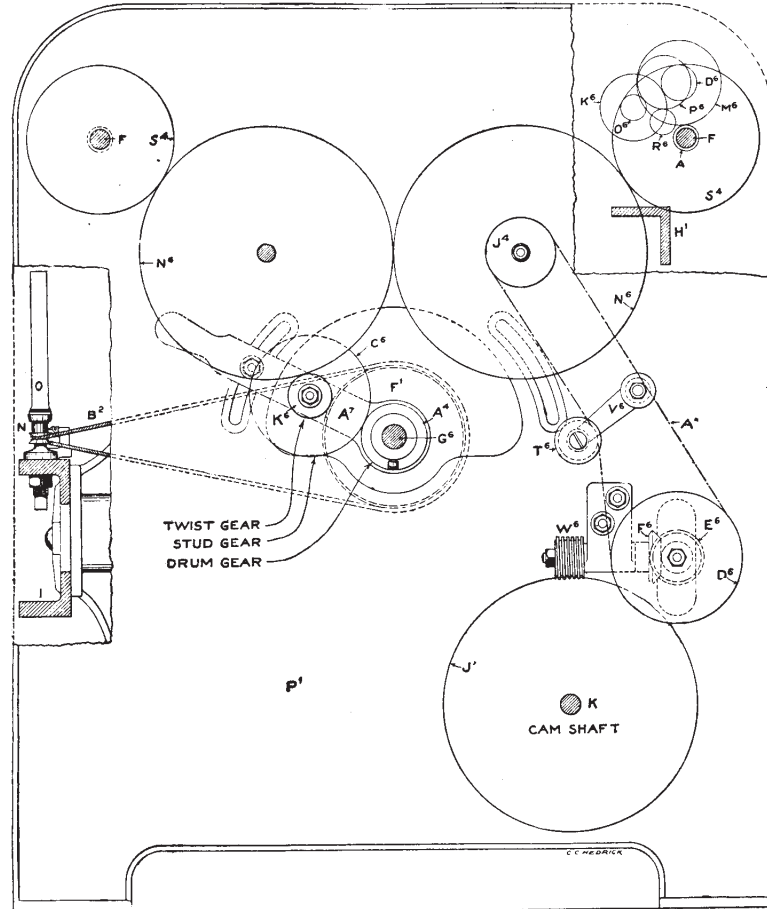

Fig. 218. End Elevation Showing Gearing.

in the drawing, it is in gear with the intermediate gear on the left hand side of the frame.

The driving belt should never be crossed, and it frequently happens that the direction of the main line is such that the front roll will turn in the wrong direction. To remedy this, the twist link is

swung over so that the twist gear will engage the intermediate gear on the opposite side from that shown in the drawing.

The drums are seven, eight or nine inches in diameter and the whirl of the spindle is three-fourths, thirteen-sixteenths, seven-eighths of an inch or one inch in diameter. The sizes, most commonly

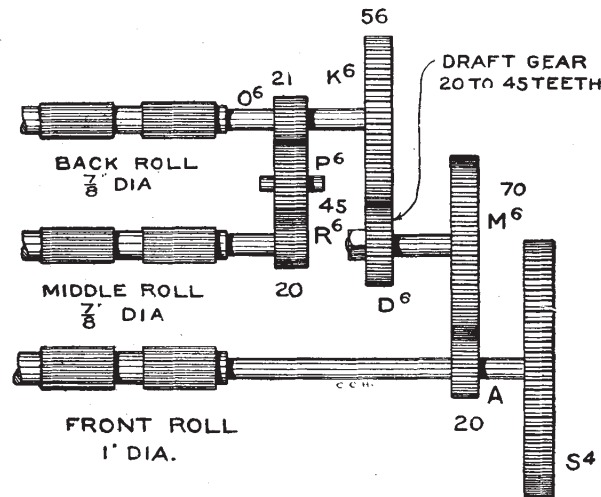

Fig. 219. Diagram of Draft Gearing.

used, are seven inch drum and three-quarters or thirteen-sixteenths inch whirl.

The spindle makes a certain number of revolutions to each revolution of the drum, and this is called "relation of drum to whirl". This relation must be known in figuring the speed of the spindle, hence the following table:

Revolutions of Spindle

Dia. of whirl	7" drum	8" drum	9" drum
$\frac{3}{4}$ "	8.12	9.20	10.72
$\frac{13}{16}$ "	7.58	8.64	9.94
$\frac{7}{8}$ "	7.05	8.10	9.45
1"	6.48	7.18	8.25

The speed of the cam shaft is often changed, as the filling wind is run at a greater speed than the warp wind. The traverse must also run at a greater speed for coarse yarn than for fine yarn. These

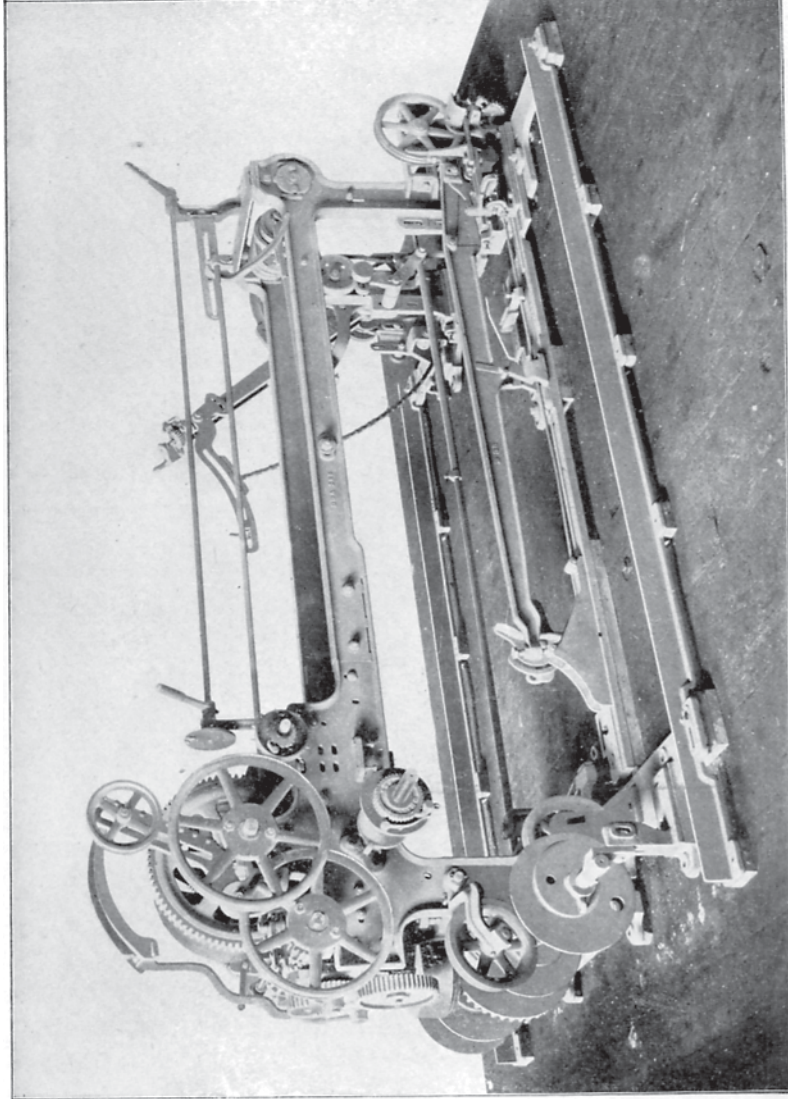

MULE HEAD — RIM AT THE SIDE
Mason Machine Works.

changes in speed are made by having a different number of teeth in either the upper or lower sprocket gear. The binder pulley, T⁶, which is carried by an arm, V⁶, is for taking up the slack of the chain when necessary.

To change the draft, various combinations are used. In the drawing, a front roll gear of twenty teeth and a crown gear of seventy

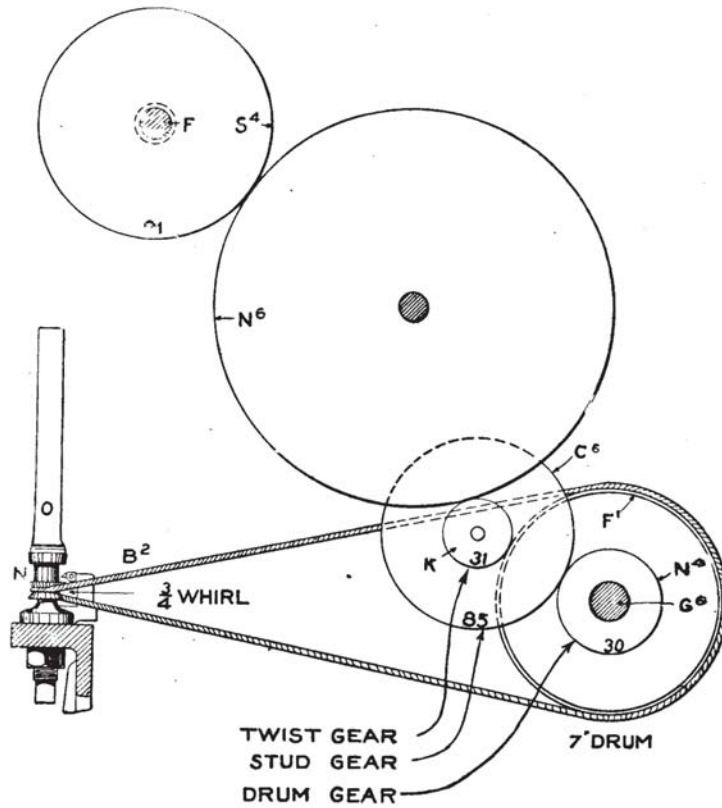

Fig. 220. Diagram of Twist Gearing.

teeth are shown. These may be changed to twenty and sixty-four teeth or thirty and one hundred four teeth.

The back roll gear shown has fifty-six teeth but it is also supplied with fifty, fifty-four or fifty-five teeth.

The regular draft gearing is sixteen pitch, but where a very fine range is wanted, the gears are made twenty-four pitch so that a change of one tooth will make a small change in the draft.

Yarn is made both right and left twist. When it is to be doubled on a twister, it is necessary to spin it with the spindle rotating in the opposite direction from that of the twister spindle. If two threads are to be twisted on a ring twister and given a right hand twist, they must have a left hand twist in spinning.

A diagram of the draft gearing is shown in Fig. 219 and the twist gearing is shown in Fig. 220.

Rule 1. To find the draft between the front and back rolls: Multiply the driven gears by the diameter of the front roll and divide the product by the product of the driving gears multiplied by the diameter of the back roll. The driven gears are M^6 and K^6 and the diameter of the front roll is 1 inch. The driving gears are A and D^6 and the back roll is $\frac{7}{8}$ inches diameter.

Example:
$$\frac{70 \times 56 \times 8}{20 \times 28 \times 7} = 8.00$$

Rule 2. To find the draft factor: Proceed as in the previous rule but omit the draft change gear D^6 .

Example:
$$\frac{70 \times 56 \times 8}{20 \times 7} = 224.00$$

Rule 3. To find the draft: Divide the factor by the number of teeth in the draft gear.

Example:
$$\frac{224}{28} = 8.00$$

Rule 4. To find the number of teeth in the draft gear: Divide the factor by the draft.

Example:
$$\frac{224}{8} = 28.00$$

Rule 5. To find the twist per inch in the yarn: Multiply the driven gears by the ratio of spindle to drum and divide the product by the product of the driving gears multiplied by the circumference of the front roll. The driven gears are C^6 and S^4 and the ratio of a $\frac{3}{4}$ inch whirl to a 7 inch diameter drum is 8.12. The driving gears are A^4 and K^6 and the circumference of the front roll is 3.14.

Example:
$$\frac{85 \times 91 \times 8.12}{30 \times 31 \times 3.14} = 21.50$$

Rule 6. To find the twist factor: Proceed as in Rule 5 but omit the twist change gear.

Example:
$$\frac{85 \times 91 \times 8.12}{21.50} = 666.75$$

Rule 7. To find the twist gear: Divide the factor by the required twist.

Example:
$$\frac{666.75}{21.50} = 31$$

Rule 8. To find the twist per inch: Divide the factor by the number of teeth in the twist gear.

Example:
$$\frac{666.75}{31} = 21.50$$

The standard twist for warp yarn is the square root of the number of yarn multiplied by 4.75. For filling yarn, multiply by 3.20. For hosiery yarn, and other soft twisted yarn, the factor is as low as 2.50, and for extra hard twisted yarns, as high as 5.00. The standard twist tables are based on the multiple of 4.75 for warp and 3.20 for filling.

Rule 9. To find the number of hanks per spindle: Multiply together the revolutions of the front roll per minute (132), the circumference of the front roll (3.14") and the estimated number of minutes run in ten hours (570). Divide the product by the number of inches in one hank (30,240).

Example:
$$\frac{132 \times 3.14 \times 5.70}{30,240} = 7.81$$

Rule 10. To find the number of pounds per spindle: Divide the number of hanks per spindle (7.81) by the number of yarn (20).

Example:
$$\frac{7.81}{20} = .39$$

Rule 11. To find the revolutions of the spindle per minute: Multiply together the revolutions of the front roll (132), the twist per inch (21.24) and the circumference of the front roll (3.14).

Example:
$$132 \times 21.24 \times 3.14 = 8803.55$$

Rule 12. To find the weight in grains per yard of any number of yarn: Divide the weight per yard of No. 1 yarn (8,333 grains) by the number of yarn (20).

Example:
$$\frac{8.333}{20} = .416$$

The production of the ring frame is governed by the speed at which the front roll can be run, and this speed is determined by the

quality and counts of yarn being spun. All machinery builders publish tables giving the speeds of the front roll and the spindle for the different numbers of yarn. These speeds are based upon the result of experiments, and may be increased ten to fifteen per cent, when the nature of the stock is such that it will allow it.

In Rules 9 and 11, the speed of the front roll, which is 132 R. P. M., is the table speed for No. 20 warp yarn; and in Rule 11 the twist per inch, which is 21.24, is the standard for No. 20 warp yarn also.

The actual time that the frame is stopped for cleaning and doffing varies very much with the number of the yarn and the quality of the cotton. This amounts to from 2 to 12 per cent.

The tables given show the speeds at which the front roll and the spindles may be safely run, for both warp and filling yarn, from numbers 4 to 60.

WARP YARN

Number of Yarn	Revs. of 1 Inch Front Roll Per Minute	Revs. of Spindle Per Minute	Hanks Per Day Per Spindle	Pounds Per Day Per Spindle	Estimated Time Run Per Day in Minutes
4	155	4600	8.64	2.16	537
5	153	5100	8.57	1.71	538
6	152	5600	8.50	1.41	539
7	150	5900	8.43	1.20	540
8	148	6300	8.36	1.04	540
9	147	6600	8.29	0.92	541
10	145	6900	8.22	0.82	542
12	142	7400	8.08	0.67	544
14	139	7800	7.93	0.56	546
16	136	8200	7.78	0.48	548
18	133	8500	7.64	0.42	550
20	130	8700	7.49	0.374	552
22	127	8900	7.34	0.333	554
24	124	9100	7.19	0.299	556
26	121	9200	7.03	0.270	558
28	118	9300	6.88	0.245	560
30	115	9400	6.72	0.224	562
32	112	9500	6.57	0.205	564
34	109	9500	6.41	0.188	565
36	106	9500	6.25	0.173	567
38	103	9500	6.09	0.160	569
40	100	9500	5.93	0.148	571
42	98	9500	5.83	0.138	573
44	96	9500	5.73	0.130	575
46	94	9500	5.63	0.122	577
48	92	9500	5.53	0.115	579
50	90	9600	5.43	0.108	581
60	85	9800	5.20	0.086	590

FILLING YARN

Number of Yarn	Revs. of 1 Inch Front Roll Per Minute	Revs. of Spindle Per Minute	Hanks Per Day Per Spindle	Pounds Per Day Per Spindle	Estimated Time Run Per Day in Minutes
4	169	3400	9.22	2.30	525
5	168	3775	9.17	1.83	526
6	166	4100	9.12	1.52	527
7	165	4400	9.08	1.29	528
8	163	4650	8.99	1.12	529
9	162	4900	8.95	0.99	530
10	160	5100	8.85	0.88	531
12	158	5500	8.75	0.72	533
14	155	5850	8.65	0.61	535
16	151	6100	8.47	0.52	537
18	147	6300	8.28	0.46	540
20	144	6500	8.14	0.407	542
22	142	6700	8.03	0.365	544
24	136	6700	7.72	0.321	546
26	134	6900	7.67	0.295	548
28	130	6950	7.47	0.266	550
30	126	6950	7.25	0.241	552
32	123	7000	7.09	0.221	555
34	119	7000	6.91	0.203	557
36	116	7000	6.74	0.187	559
38	114	7100	6.68	0.175	561
40	112	7150	6.58	0.164	563
42	110	7200	6.49	0.154	565
44	108	7200	6.37	0.144	567
46	105	7200	6.25	0.135	570
48	103	7200	6.14	0.128	572
50	101	7200	6.04	0.102	574
60	93	7300	5.69	0.094	585

The draft of the ring frame varies much with the quality of cotton, the number of yarn being spun and whether the yarn is single or double roving.

It is a fault, with many mill superintendents, to have the hank roving, of the fine fly frame, coarse so the production will be large which makes the draft of the ring frame long. This is productive of uneven yarn, particularly when spun from single roving. In many cases, the roving should be made fine enough so that the draft will be from six to eight for single roving and from eight to twelve for double roving.

The following program is for a mill, making flat duck, seven to twelve ounces per yard, number ten warp, number five and one-half filling from single roving.

PROGRAM OF DRAFTS AND WEIGHTS

NO. 10 WARP. NO. 5½ FILLING

Weight of Picker Lap.....	16 ounces
Weight of Card Lap less 5 per cent	6630 grains
Draft of Card.....	102
Weight of Card Sliver.....	65 grains
Double on Drawing Frame, 1st process.....	6
Draft on Drawing Frame, 1st process.....	5.4
Weight of Drawing Sliver, 1st process.....	72.2 grains
Double on Drawing Frame, 2nd process.....	6
Draft on Drawing Frame, 2nd process.....	5.4
Weight of Drawing Sliver, 2nd process.....	80.2 grains
Draft of Slubber.....	4.80
Hank Roving of Slubber.....	.50
Double on Fine Frame.....	2
Draft on Fine Frame	4.00 and 5.20
Hank Roving of Fine Frame	1.00 and 1.30
Draft of Ring Frame.....	5.50 and 7.70
No. of Yarn.....	5.50 filling and 10 warp

The slubber roving is .50 hank; and on account of the extreme difference between the warp and filling yarn, it is necessary to make two numbers of roving, on the fine frame, namely, 1.00 hank and 1.30 hank.

The weight of the picker lap is given in ounces per yard, but the weight of the card lap is given in grains per yard, as the weight of the card sliver is expressed in grains and the draft can be figured more easily.

The weight of the card lap is figured as five per cent less than the picker lap. Actually, there is no difference, as the lap from the finisher picker goes directly to the back of the card, but as there is a loss of about five per cent in carding, it is customary to take this amount out of the weight of the lap.

The weight of slubber roving is given by the hank and, to find the necessary draft to make the required hank roving, the following rule may be used: Multiply the weight of the drawing sliver (80.2 grains) by the required hank roving and divide by the weight of number one hank roving (8.333 grains).

Example:
$$\frac{80.2 \times .50}{8.333} = 4.81 +$$

The next program is that of a mill, making cotton cloth, weighing about three yards to the pound, thirty-six inches wide, number fourteen warp and filling yarn, from single roving.

PROGRAM OF DRAFTS AND WEIGHTS

NO. 14 WARP. NO. 14 FILLING

Weight of Picker Lap.....	14	ounces
Weight of Card Lap less 5 per cent.....	5818	grains
Draft of Card.....	.97	
Weight of Card Sliver.....	.60	grains
Double on Drawing Frame, 1st process.....	.6	
Draft of Drawing Frame, 1st process.....	.6	
Weight of Drawing Sliver, 1st process.....	.60	grains
Double on Drawing Frame, 2nd process.....	.6	
Draft of Drawing Frame, 2nd process.....	.6	
Weight of Drawing Sliver, 2nd process.....	.60	grains
Double on Drawing Frame, 3rd process.....	.6	
Draft of Drawing Frame, 3rd process.....	.6	
Weight of Drawing Sliver, 3rd process.....	.60	grains
Draft of Slubber.....	5.00	
Hank Roving of Slubber.....	.70	
Double on Fine Frame.....	.2	
Draft of Fine Frame.....	5.70	
Hank Roving of Fine Frame.....	2.00	
Draft of Ring Frame.....	7.00	
No. of Yarn.....	14.00	

The third program is for a yarn mill also making fourteen yarn but from double roving.

PROGRAM OF DRAFTS AND WEIGHTS

NO. 14 HOSIERY YARN

Weight of Picker Lap.....	14	ounces
Weight of Card Lap less 5 per cent.....	5819	grains
Draft of Card.....	1.00	
Weight of Card Sliver.....	.58	grains
Double on Drawing Frame, 1st process.....	.6	
Draft of Drawing Frame, 1st process.....	.6	
Weight of Drawing Sliver, 1st process.....	.58	grains
Double on Drawing Frame, 2nd process.....	.6	
Draft of Drawing Frame, 2nd process.....	.6	
Weight of Drawing Sliver, 2nd process.....	.58	grains
Draft of Slubber.....	3.5	
Hank Roving of Slubber.....	.50	
Double on Intermediate.....	.2	
Draft on Intermediate.....	4.4	
Hank Roving of Intermediate.....	1.10	
Double on Fine Frame.....	.2	
Draft of Fine Frame.....	5.5	
Hank Roving of Fine Frame.....	3.00	
Double on Ring Frame.....	.2	
Draft of Ring Frame.....	9.4	
No. of Yarn.....	14.00	

Yarn, spun from double roving, produces a more even thread than that spun from single roving, owing to the doubling of the two ends. A thin or light place, in one end, will be offset by the other end, but if an end breaks or runs out, the yarn spun from the remaining end will be "single" and of incorrect weight.

The last program is for a mill making mule-spun hosiery yarn, numbers ten to twenty-four, from 2.30 and 4.00 hank roving, double.

PROGRAM OF DRAFTS AND WEIGHTS

FROM 10's TO 24's HOSIERY YARN

Weight of Picker Lap.....	14 ounces
Weight of Card Lap less 5 per cent	5819 grains
Draft of Card.....	100
Weight of Card Sliver	58 grains
Double on Drawing Frame, 1st process.....	6
Draft of Drawing Frame, 1st process	6
Weight of Drawing Sliver, 1st process.....	58 grains
Double on Drawing Frame, 2nd process.....	6
Draft of Drawing Frame, 2nd process.....	6
Weight of Drawing Sliver, 2nd process.....	58 grains
Double on Drawing Frame, 3rd process.....	6
Draft of Drawing Frame, 3rd process.....	6
Weight of Drawing Sliver, 3rd process.....	58 grains
Draft of Slubber.....	3.83
Hank Roving of Slubber	55
Double on Intermediate.....	2
Draft of Intermediate	4 and 5.2
Hank Roving of Intermediate	1.10 and 1.43
Double on Fine Frame.....	2 and 2
Draft of Fine Frame.....	4.4 and 5.7
Hank Roving of Fine Frame	2.42 and 4.00
Double on Mule.....	2 and 2
Draft of Mule.....	9.1 and 12.00
No. of Yarn.....	11.01 and 24.00

NO. OF YARN 10's

Hank Roving of Fine Frame... 2.30
Double on Mule..... 2
Draft of Mule..... 8.7
No. of Yarn

NO. OF YARN 16's

Hank Roving of Fine Frame... 4.00
Double on Mule..... 2
Draft of Mule..... 8
No. of Yarn

NO. OF YARN 11's

Hank Roving of Fine Frame... 2.30
Double on Mule..... 2
Draft of Mule..... 9.6
No. of Yarn.....

NO. OF YARN 18's

Hank Roving of Fine Frame... 4.00
Double on Mule..... 2
Draft of Mule..... 9
No. of Yarn.....

NO. OF YARN 12's		NO. OF YARN 20's	
Hank Roving of Fine Frame...	2.30	Hank Roving of Fine Frame...	4.00
Double on Mule.....	2	Double on Mule.....	2
Draft of Mule.....	10.5	Draft of Mule.....	10
No. of Yarn.....	12.07	No. of Yarn.....	20.00
NO. OF YARN 14's		NO. OF YARN 24's	
Hank Roving of Fine Frame...	2.30	Hank Roving of Fine Frame...	4.00
Double on Mule.....	2	Double on Mule.....	2
Draft of Mule.....	12.2	Draft of Mule.....	12
No. of Yarn.....	14.03	No. of Yarn.....	24

MULE SPINNING

Briefly speaking, the mule consists of three parts: The beam for supporting the rolls, creels, etc; the carriage which contains the drums spindles, fallers and parts directly connected; and the headstock, or mule head, which contains the various parts that control the movements of the machine. The mules are placed in pairs, as shown in Fig. 221, with the carriages toward each other, the headstock is located a little nearer one end of the mule than the other, thus making a long and a short side to the mule carriage, the short side always being to the right hand of the headstock.

In explanation, the operations of the mule may be divided into four stages. The first stage is called drawing and twisting; the

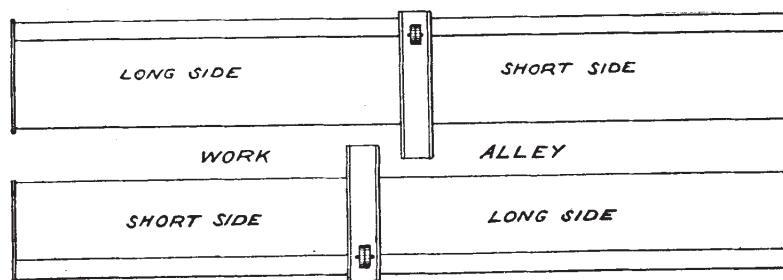

Fig. 221. Plan of a Pair of Mules.

second, backing off; the third, winding and the fourth, re-engaging.

The roving is placed in the creels and passes through the rolls by which it is drawn in the same manner as on the ring frame.

An elevation of the mule carriage is shown in Fig. 222 and a plan of the gearing, in Fig. 223. The spindles, L^5 , and the drum, C^6 , are in the carriage, E , which moves back and forth in a horizontal direction upon tracks, E^6 , which are called carriage tracks.

When the operation of drawing and twisting commences, the carriage is at the innermost point of its traverse, the point nearest the rolls, and as the rolls revolve and deliver the yarn, the spindles

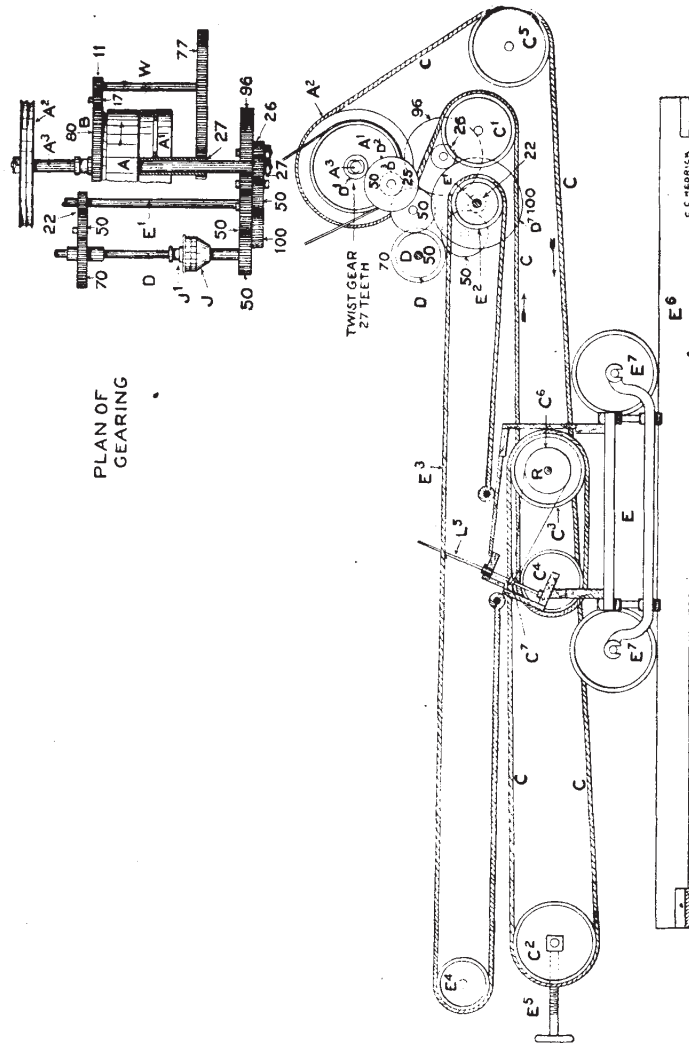

Fig. 222. Elevation of Mule Carriage.

commence to turn and at the same instant, the carriage begins its outward run and the yarn, being delivered by the rolls, is kept under a slight tension and is twisted; when the carriage reaches the end of

The speed of the driving pulley is 500 R. P. M. The spindles are driven from the rim or twist pulley, A², which is eighteen inches in diameter and which is fast on the driving shaft, A³. The rim band, C, runs from the rim pulley around the carrier pulley, C¹, which is fastened to the headstock. From this point, it passes forward and around the carrier pulley, C⁴, which is upon the carriage, and then passes back and around the drum pulley, C³, which is ten inches in diameter. From here, the band passes forward around the carrier pulley, C², which is carried by an adjustable screw, E⁵, and which is used for keeping the band tight, then it passes back and around a carrier pulley, C⁵, and back to the twist pulley.

The drum, C⁶, is six inches in diameter and the whirl, C⁷, is three-quarters of an inch. The speed of the spindles will be 7105 R. P. M.

Example:
$$\frac{18 \times 6}{10 \times 7.5} \times 500 = 7105$$

The front roll, D, is driven from the main shaft by the twist gear, D¹, which has twenty-seven teeth, and the gears, D², of fifty teeth, D³, of twenty-five teeth and the front roll gear, D⁴, of fifty teeth.

The speed of the front rolls will be 135 R. P. M.

Example:
$$\frac{27 \times 25}{50 \times 50} \times 500 = 135$$

The front roll is one inch in diameter, therefore, 135 revolutions will give a delivery of 423.90 inches of yarn and during this time, the spindles have made 7105 revolutions.

The twist, therefore, will be 16.76 twists per inch.

Example:
$$\frac{7105}{423.90} = 16.76$$

The carriage, E, is drawn out by the back, or carriage shaft, E¹, which extends the whole length of the mule and has fast upon it three scrolls, E², one in the center and one at each end (the end ones are not shown), which are about seven inches in diameter but terminate at the ends in a smaller diameter.

The drawing-out bands, E³, which are fastened to the carriage, pass back and around the scrolls and around carrier pulleys, E². The center carrier pulley runs loose upon the quadrant shaft while the end ones turn on studs which are screwed to the ends of the mule

framing. From the carrier pulleys, the bands pass back and are fastened to the mule carriage.

The carriage shaft is driven from the front roll gear of fifty teeth and through the intermediate gear of fifty teeth and the gears of ninety-six and twenty-six teeth and the carriage shaft gear, D', of one hundred teeth. The speed of the carriage shaft is 18.28 R. P. M.

Example:
$$\frac{50 \times 26}{96 \times 100} \times 135 = 18.28$$

The scrolls are about seven inches in diameter and the scroll band will be about seven and one-half inches in diameter when passed around the scroll.

The traverse of the carriage will then be 430.67 inches per minute.

Example:
$$7.5 \times 3.1416 \times 18.28 = 430.67$$

The stretch of the carriage is sixty-four inches and as the carriage runs at the rate of 430.67 inches per minute, each stretch of sixty-four inches will require about nine seconds time and as the rolls deliver the yarn at the rate of 423.90 inches per minute, in nine seconds, they will deliver $\frac{9}{60}$ of 423.90 which is 63.58 inches. This shows that the carriage travels a slight distance more than the inches delivered by the front roll. This excess in travel is called the "gain" of the carriage and amounts sometimes to two or three inches in each stretch, depending upon the quality and length of the cotton staple.

The advantage of the carriage gain is to subject the yarn to a slight draft after it has left the rolls and as the twist in the yarn always runs to the thin places, this additional drawing elongates the soft or untwisted places which are thicker or larger in diameter and thus a more even thread is produced.

Long staple cotton will permit of considerable draft, but with short cotton little or no draft can be given the yarn after it has left the rolls.

At the commencement of the outward run of the carriage, the drawing-out bands are wound upon the large diameter of the scrolls and the carriage runs at a uniform speed, but, as the scrolls terminate in a smaller diameter, the carriage moves at a relatively slower speed as it approaches the end of the run.

Backing-Off Motion. The next stage in the operations is called the backing-off. By this is meant the reversion of all the necessary parts from the position, occupied during the outward run, to the posi-

about by the backing-off friction wheel, B, being brought into contact with the tight pulley, A (Fig. 222).

The cone clutch on the cam shaft is put in gear, and, just previous to the carriage arriving at the end of the run, the belt is moved on the loose pulley, allowing the carriage to finish the stretch by its momentum.

At this point, it will be well to explain just how the backing-off friction changes the direction of the rotations of the spindles.

The backing-off friction acts first as a stop for the rim, or driving shaft, and secondly, to impart motion to it in the opposite direction. The backing-off friction revolves all of the time because a part of the driving belt is upon the loose pulley at all times and as the latter drives the backing-off wheel by the gear of twenty-seven teeth, which is fast upon the hub of the loose pulley, and the gears of seventy-seven and eleven teeth, which are upon the backing-off shaft, W, and the backing-off wheel of eighty teeth. The last is driven in the opposite direction from the tight pulley at a very slow speed and, when suddenly thrown into contact with the tight pulley, the friction acts first as a brake and then turns the spindles a few revolutions, in the opposite direction, before it is drawn out of contact.

In Fig. 225, is shown the device by which the backing-off friction is operated. In the hub of the friction is a groove, in which runs a clutch lever, P¹, with its fulcrum at P². The long end of the lever is connected to a bell crank, P³. To the end of this bell crank is fastened one end of the backing-off rod, B¹, the other end being connected to the backing-off lever, O⁵, by the spring, O⁶. The backing-off lever is fastened to the headstock by a stud, S⁷.

As the carriage moves out, the tight pulley, A, and the backing-off friction, B, are disengaged, but when the carriage arrives at the end of the run, the backing-off arm, K⁷, comes against the roll, S⁶, which is upon the lever, O⁵, the last, being raised. By so doing, the rod, B¹, is drawn forward in the direction shown by the arrow, the friction is caused to engage with the tight pulley, and the spindles are rotated in the opposite direction.

After the spindles have unwound sufficient length of yarn, by their reverse movement, it is evident that they must be stopped else too much yarn will be unwound. This is accomplished by the locking of the fallers, whose movement causes the backing-off arm, K⁷, to be

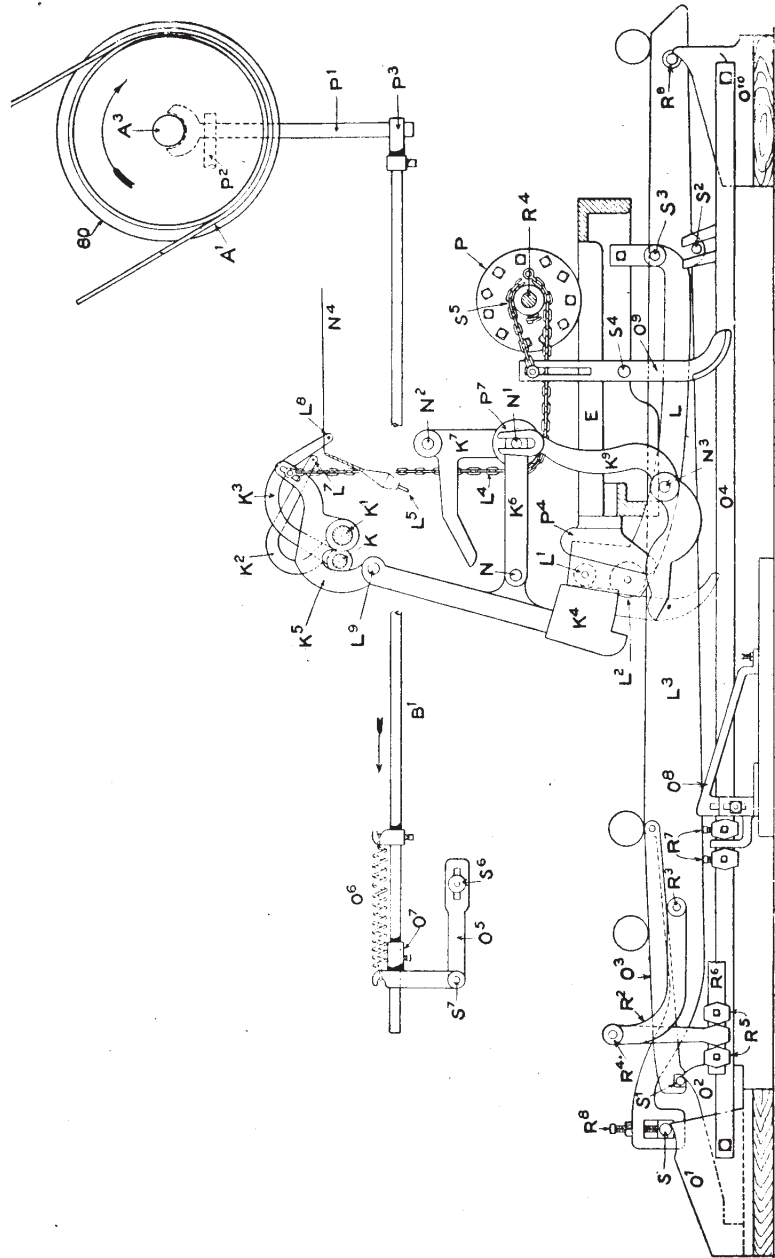
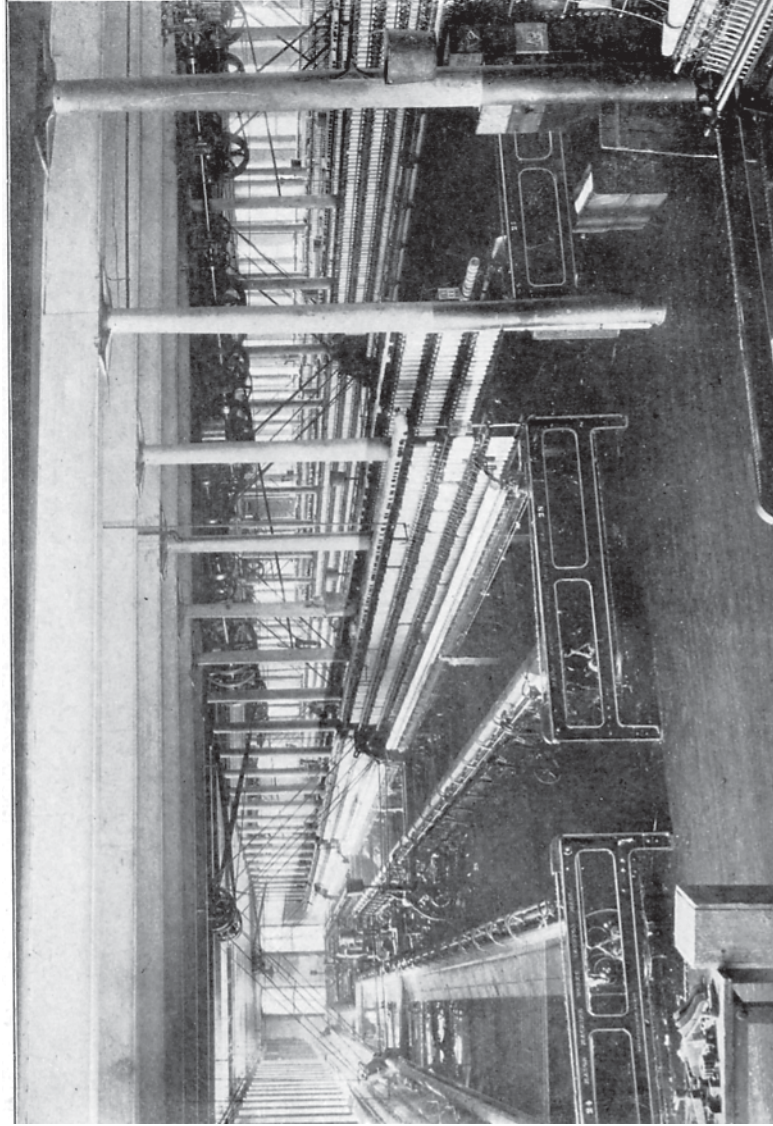

Fig. 225. Elevation Showing Details of Mule Carriage.



POTOMSKA MILLS, MULE ROOM
Mason Mules on Fine Yarns.

dropped, suddenly, out of contact with the roll on the backing-off lever; this allows the spring, O^6 , to draw back on the lever which comes against the collar, O^7 , upon the backing-off rod, moving the rod back and the friction becomes disengaged.

The fallers are drawn down and locked in the following manner: Upon the drum shaft, R^4 , is a plate, P , to the hub of which is fastened one end of the backing-off chain, L^4 , the other end being fastened to an arm, K^5 , which is upon the winding faller shaft, K^1 . During the operation of drawing and twisting, the revolutions of the drum

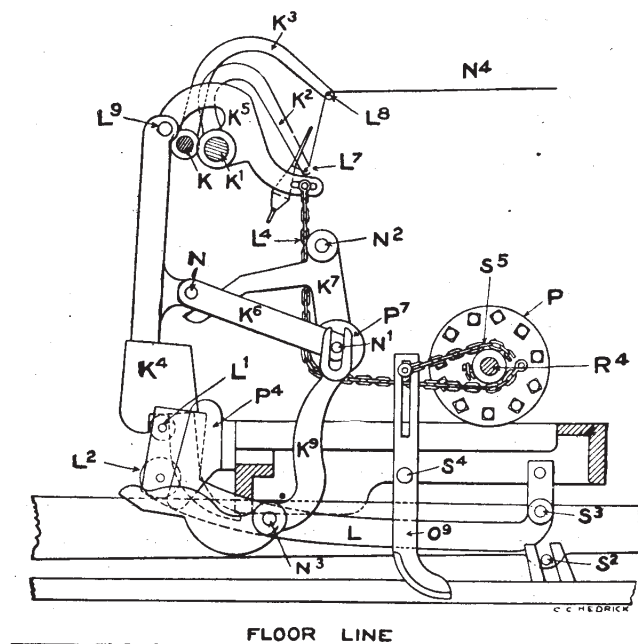

Fig. 226. Elevation Showing Details of Mule Carriage.

shaft have no effect on the plate, as it is loose upon the drum shaft. But when the direction of the drum shaft is reversed, to unwind the yarn from around the spindles, the plate also rotates, being driven by a pawl and ratchet. The chain is thus wound around the hub of the plate and the faller is drawn down into the position for winding as shown in Fig. 226.

Resting upon the top of the builder, or copping rail, L^3 , is the copping rail roll, L^2 , which is supported by an arm, L , called the

trailer and which is fastened to the carriage by a stud, S^3 . The forward end of this arm is free to swing up and down, and is supported by a guide, P^4 . Just above the roll, L^2 , is a similar roll, L^1 , called the locking roll against which rests the lower end of a lever, K^4 , which is called the faller lock. This lock is hung from the arm, K^5 , which is fastened to the winding faller shaft, K^1 .

When the carriage is on its outward run, the faller lock rests against the locking roll as shown in Fig. 225. But when the direction of the drum is reversed and the faller is drawn down into position for winding, the faller lock is drawn upwards, until the recess in its lower part is raised high enough to fall forward over the locking roll, as shown in Fig. 226, in which position the lock remains during the inward run.

In transferring the driving belt on to the loose pulley, just previous to the arrival of the carriage at the end of its outward run, a great saving in time is made by a quicker backing-off. The device which

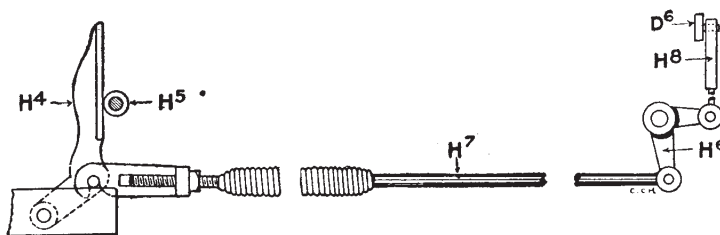

Fig. 227. Belt Relieving Motion.

controls this motion is called the belt relieving motion and is shown in Fig. 227. As the carriage comes out, a projecting part, H^5 , comes against the lever, H^4 , which through the rod, H^7 , bell crank, H^6 , and connection, H^8 , moves the belt guide, D^6 , on to the loose pulley.

During the backing-off and while the fallers are being locked, the carriage is held rigidly for a brief period to enable this motion to operate before the carriage starts on its inward run. If some means were not provided, the carriage, upon arriving at the end of the outward run, would start back before the backing-off and the locking of the fallers could take place. To prevent this, the mule is provided with a holding-out catch which is shown in Figs. 225 and 226. Fastened to the carriage by a stud, N^3 , is a lever, K^9 , called the holding-out finger, while upon the fore part of the headstock is a lever, R^2 , called the holding-out lever, one end of which is provided with a roll, R^3 , the

other end is fastened to the holding-out rod, R⁶, by collars, R⁵. This lever has, for its fulcrum, a stud, R⁴.

When the carriage arrives at the end of the outward run, the holding-out finger comes against the roll in the end of the holding-out lever and holds it firmly in position. By so doing, the drawing-up friction, by which the carriage is drawn in, is held out of gear. When the backing-off is completed and the fallers locked, the finger is lifted clear of the roll and the holding-out rod allows the drawing-up friction to drop into gear.

Backing-Off Chain Tightening Motion. We have seen, already, that at the end of the outward run, and after the carriage has come to a dead stop, the winding faller descends and guides the yarn

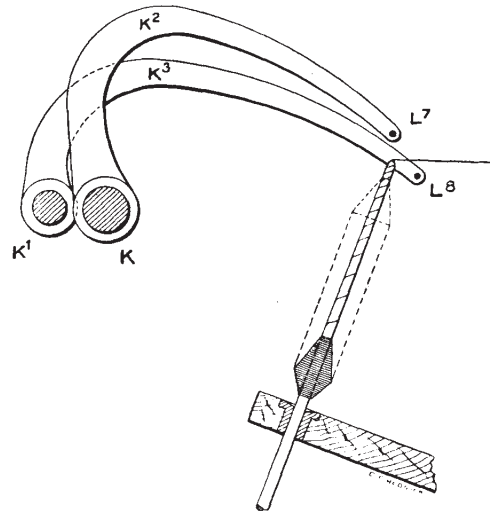

Fig. 228. Elevation Showing Fallers.

on to the spindle, while the counter faller rises until it meets the yarn, acting as a tension upon it. There remains to explain, in connection with the fallers, the different conditions under which they must work.

When drawing and twisting take place during the outward run of the carriage, the fallers are in the position shown in Fig. 228. The winding faller, K², is above the yarn and the counter faller, K³, is below, both clear of the yarn. But during the operation of backing-off, the fallers are made to assume the position shown in Fig. 229.

The winding faller descends and guides the yarn on to the spindles, and the counter faller rises until it meets the underside of the yarn and acts as a tension upon it.

When the cop is in the early stages of formation, the length of yarn, unwound from the bare spindle between the cop and point, is considerable, as shown in Fig. 230 by the distance between the point of the spindle, A, and the top of the cop, B. In order to move the yarn from A to B, the winding faller wire must descend from C to D while the counter faller wire rises from E to F.

As the cop grows longer and the position of the winding gradually approaches the top of the spindle, the length of yarn to be unwound is considerably less as shown by the distance between G and H in

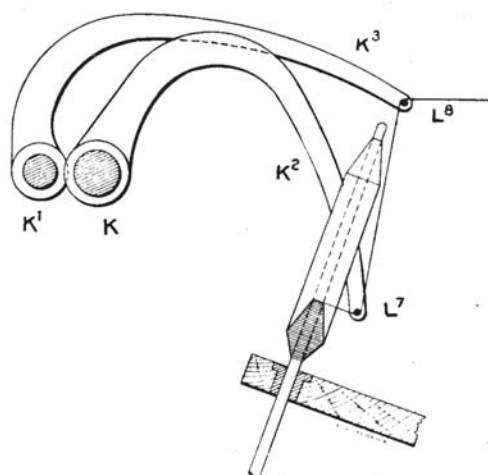

Fig. 230. Elevation Showing Fallers.

Fig. 231. The winding faller will move from K to L only and the counter faller, from M to N. It will thus be seen that the movements of the fallers, during the early stages of the building of the cop, are considerably greater than when approaching the finish and that the length to be unwound, from around the bare spindle, is considerably more, and it follows that the revolutions given to the spindle in a reverse direction must gradually decrease.

The gradual decrease in the revolutions of the spindle and the distance moved by the faller wires are regulated by the backing-off chain tightening motion.

We have seen that the fallers are drawn down by the backing-off chain, which is wound around the backing-off plate, P, by the reverse direction of the drum.

During the first part of the formation of the cop, a slack backing-off chain is of no objection, as it gives the spindles an opportunity to unwind the yarn before the faller wires move down. In Fig. 230, the faller wire moves from C to D in about the same time as it does from K to L in Fig. 231. This is a very much shorter distance, and, unless the spindles have unwound a considerable length of yarn, there is great danger of the winding faller wire overtaking and breaking the yarn.

As the cop grows longer, and the reverse movement of the spindles less, there is not as much danger of this as the movement from the position, occupied during spinning, to that which is necessary for winding, is considerably less and the faller starts downward earlier at each layer wound until, at the finish, it comes down and just touches the yarn the moment the spindles commence their reverse movement.

The device, by which this motion is governed, is shown in Fig. 225 and is operated in the following way. Attached to the backing-off plate is one end of the tightening chain, S⁵, the other end is fastened to a lever, O⁹, called the chain tightening lever, which turns on a stud, S⁴. As the carriage moves out, this lever hangs in a position which causes its lower end to just touch the chain tightening incline, O⁸. This incline is fastened to the builder shoe connecting rod, O⁴, which connects the front and back builder shoes.

As the building of the cop progresses and the builder shoes are moved back, the incline is brought more and more into the path of the

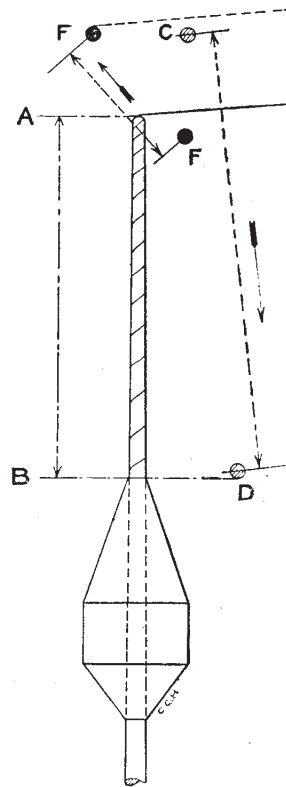

Fig. 230. Diagram Showing Movement of Fallers.

chain tightening lever which causes the lever to unwind the tightening chain and to wind the backing-off chain on to the plate. By this movement, the slack, which exists in the backing-off chain during the early stages of the cop building, is gradually taken out and the fallers are drawn down a little earlier for each stretch of the carriage.

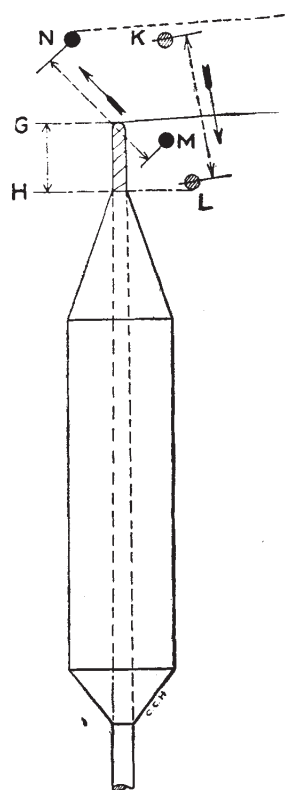

Fig. 231. Diagram Showing Movement of Fallers.

Covering almost the whole length of the cam shaft is a shell or sleeve, D^8 , called the cam shaft sleeve upon which are the various cams. The first one is the cam clutch and is made in halves, one piece, D^2 , is fastened to the cam shaft and the other half, D^3 , to the sleeve. The second cam is the front roll clutch cam, J^8 ; the third is the carriage shaft clutch cam, H^3 ; and the fourth is the shipper cam, I^5 .

Winding. The third stage in the operations of the mule is called winding.

Immediately after the fallers have been brought into position and locked, the carriage commences its inward run, and the spindles rotate in the same direction as when twisting and, in so doing, wind on to the cops the yarn that is released as the carriage runs in. The winding faller descends rapidly, and guides a few coils down the cop and then rises very slowly and arrives at the starting point as the carriage reaches the end of its inward run.

Before describing the winding operation, it is necessary to know what causes the carriage to be drawn inward and also to understand the changes that take place by the partial rotation of the cam shaft sleeve.

In Fig. 224 is shown a detail of the cam shaft and in Fig. 232 an end elevation.

The cam shaft, D^1 , rotates all of the time that the mule is running and is driven from the backing-off shaft by the gears of nineteen and thirty-eight teeth.

On the outside of the headstock are two levers, B⁶ and B⁷, called the front and back change motion levers and which are connected by a rod, B⁵, called the change motion rod. On the forward end of the rod is the shipper dog, B⁴, which operates the cam clutch lever, B².

Just as the carriage reaches the end of the outward run, a roll B⁹, which is carried by a stand, forming part of the carriage, comes against the lever, B⁶, and causes the rod to move forward and with it

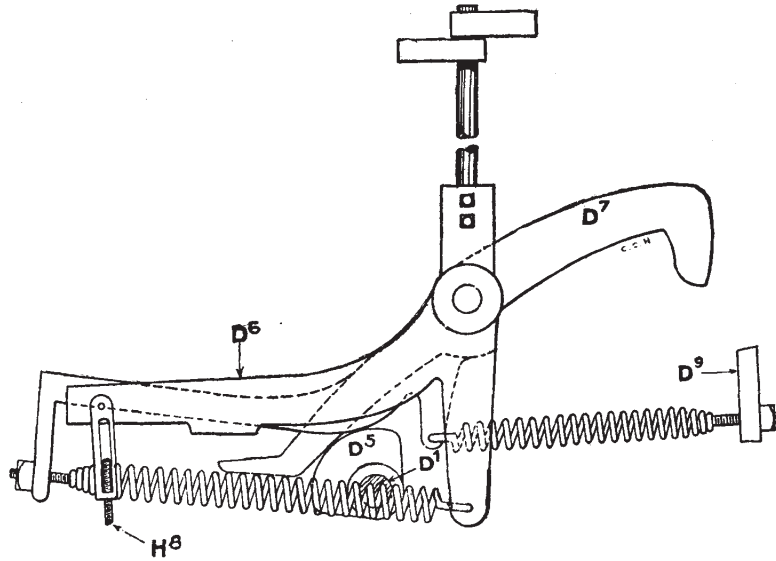

Fig. 232. End Elevation of Cam Shaft.

the cam clutch lever. This movement causes the two parts, D² and D³, of the cam clutch to engage and the cam shaft shell is given a half revolution, causing all of the cams to assume opposite positions to those which they occupied during the outward run.

When the cam sleeve has made a half revolution, the clutch is caused to be disengaged by the peculiar shape of the cam clutch lever.

In Fig. 233, it will be seen, that both parts, J and J¹, of the front roll clutch, are engaged and we will assume that the front roll is revolving, which is the case when the carriage runs out, but when the cam sleeve changes, the position of the cam is directly opposite from that which is shown in the drawing. This disengages the clutch and stops the rotation of the front roll.

Fig. 234 shows both parts, H and H¹, of the carriage shaft clutch

as engaged for drawing the carriage out, but with the changing of the cam sleeve, the clutch is disengaged and the revolutions of the carriage shaft cease. H^1 is made in two pieces with corrugated faces which are kept in contact by a heavy steel spring, W^6 . Should anything obstruct the outward movement of the carriage, this spring will "give" and allow the clutch to rotate without imparting movement to the carriage.

In the end elevation (Fig. 232) the belt shipper cam, D^5 , is shown in the position necessary on the outward run. The belt is upon the

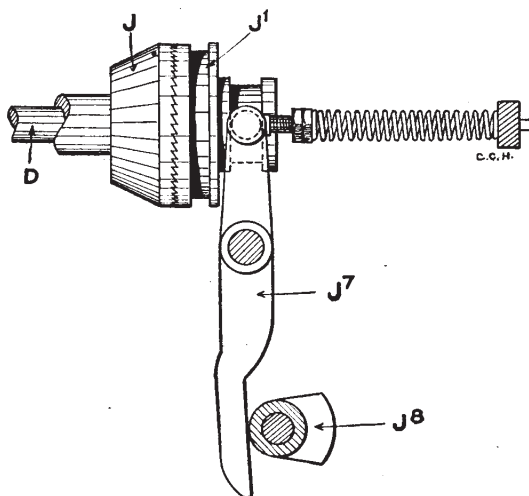

Fig. 233. Elevation Showing Front Roll Clutch.

tight pulley, but with the half revolution of the cam sleeve, the belt guide is locked into position over the loose pulley.

We have already seen that just before the carriage arrives at the end of the outward run, the belt is moved on to the loose pulley by the belt relieving motion, but unless the belt is locked into position by the shipper cam, it will be moved back on to the tight pulley by the inward run of the carriage.

The carriage is drawn in, in the following manner: On the scroll shaft, R^{10} , Fig. 223, are the scrolls, A, B and C, upon which are wound the drawing-up bands. The scroll shaft is driven from the backing-off shaft through the gears of fifteen, nineteen, thirteen and thirty-eight teeth.

On the lower end of the drawing-up shaft, S, is the drawing-up

friction, P, which rotates with the shaft. The bottom of the friction, T³, upon which is the bevel gear of thirteen teeth, is mounted loosely upon the shaft.

During the outward run, the scroll shaft is caused to rotate by the movement of the carriage, but when the outward movement ceases and the cam shell changes, the drawing-

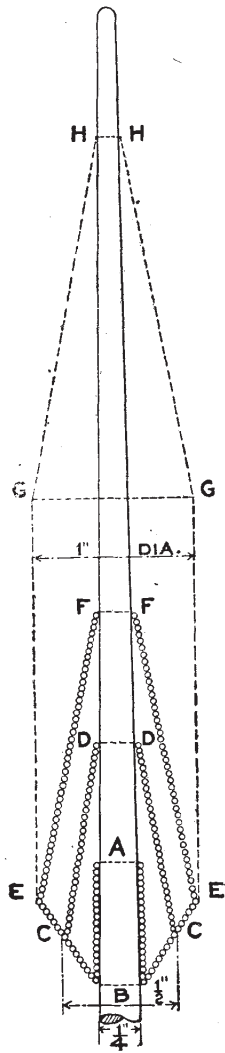

Fig. 235. Diagram of Cop Showing Winding.

that the spindles shall be given a sufficient number of revolutions, and at the correct speed, to wind on this length as it is released by the inward run.

We will assume, that while winding the first layer, the spindle

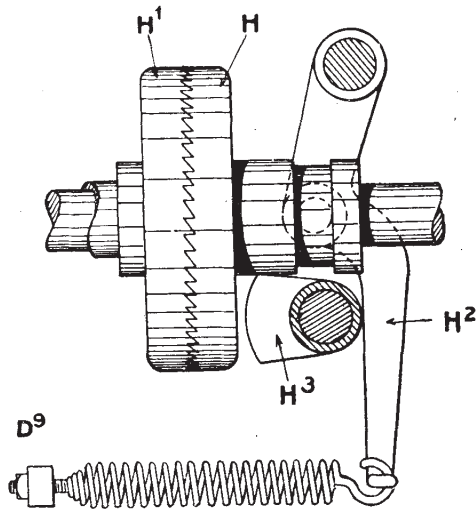

Fig. 234. Elevation Showing Carriage Shaft Clutch.

up friction, P, engages with the lower part, T³, and the carriage is drawn in. The scrolls, A and B, serve for this purpose, while the scroll, C, acts as a check upon the carriage. The scroll band unwinds from C while the other bands are winding around A and B.

It will be necessary to refer to Fig. 235 to understand the actual winding operation. During the outward run, sixty-four inches of yarn have been delivered and it is necessary

will be one-quarter inch diameter in the distance, A-B, and it must be revolved at a constant speed to wind the sixty-four inches, but as succeeding layers are added, and the diameter of the cop increases, the commencing point is higher each time and the finishing point is raised at a greater proportion. This lengthens the "chase", as the surface of the cop is called, which is shown by the line, C-D. There is produced a cone-shaped surface until, when the cop reaches its full diameter, as shown by the lines, E-E, the commencing and finishing points are raised in the same proportion at each stretch, which forms a straight cylindrical shape as shown by the outlines, E-E and G-G.

When winding the first layer, the speed of the spindle must be constant and, as its diameter is one-quarter of an inch, 81.48 revolutions will be necessary to wind sixty-four inches of yarn.

$$\frac{64}{.25 \times 3.1416} = 81.48$$

When the cop reaches the diameter shown at C-C, which we will call one-half of an inch, its speed at the bottom must be 40.74 revolutions.

$$\frac{64}{.5 \times 3.1416} = 40.74$$

As the winding moves up the cone, the speed of the spindle increases until at the point, DD, which is one-quarter of an inch in diameter, its speed is 81.48 revolutions.

When the cop reaches its full diameter at EE, which we will call one inch, its speed must be 20.37 R. P. M. or one-fourth as great as the speed of the bare spindle.

It will be seen that the increase in speed of the spindle must be proportionate to the decrease in its diameter, as the yarn is wound up toward the top of the chase, and the speed decreases for each new layer, while the bottom of the cop is being formed, until the full diameter is reached. From this point, the speed of the cop, at the commencement of each layer, is the same, 20.37 R. P. M., while the speed of the spindle, at the finish of each layer, is also the same, 81.48 R. P. M., except the number of revolutions necessary to compensate for the taper of the spindle which will be considered later.

Quadrant. When the carriage runs out, the spindles are driven by the rim band, but when winding, the spindles are caused to rotate

by the quadrant chain, Q^1 , one end of which is attached to the quadrant arm, Q , the other fastened to the winding drum, W^5 , as shown in Fig. 223. Connected to this drum is a gear of sixty-eight teeth, which

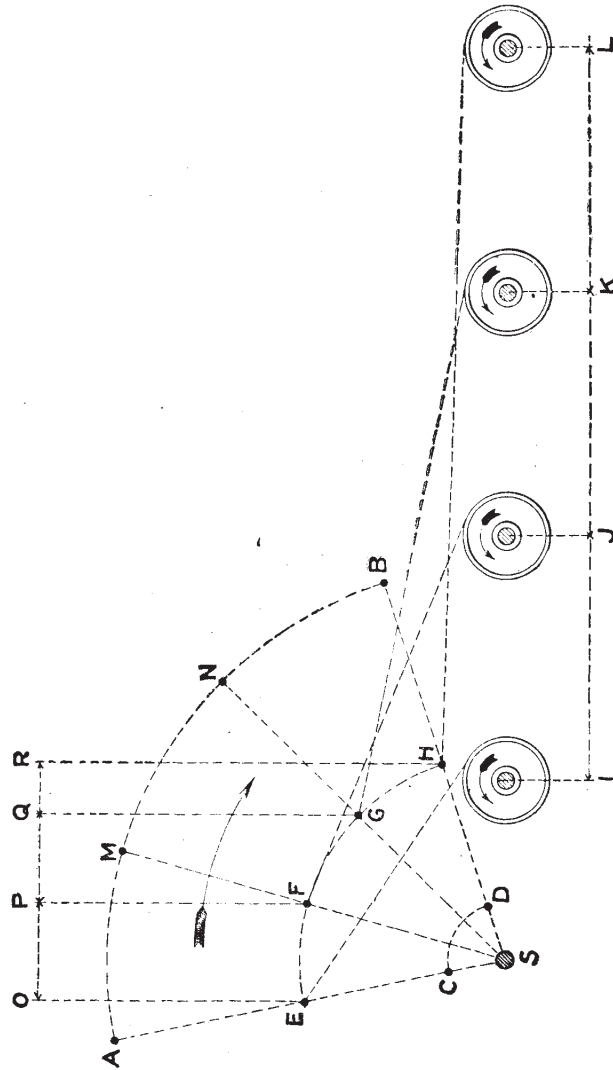

Fig. 236. Diagram of Quadrant Arm and Winding Drum.

drives a gear of thirty-four teeth, the latter connected to the drum shaft by a pawl and ratchet; the spindle drum makes two revolutions to one of the winding drum.

While drawing and twisting are going on, the winding drum is driven by a special band and the chain is wound.

Fig. 236 is a diagram of the quadrant arm and winding drum in several positions. The quadrant arm moves about ninety degrees, from A to B, while the carriage is making the whole of its run from I to L. While the first layer is winding, the nut by which the chain is attached to the arm is at C, its lowest position, nearest the fulcrum at S, and as the quadrant arm moves the ninety degrees, this point will move to D while the carriage moves the whole length of the inward run.

The movement of the nut as compared to the movement of the carriage will be very slight, and the spindles will be rotated at nearly a uniform speed.

When the cop has reached one-half inch diameter, the nut will have moved up the arm to a point at E. Here it is shown in four positions marked, E, F, G and H. The winding drum is shown also in four positions, marked I, J, K and L.

When the nut moves from E to F, the chain will have moved in a horizontal line, equal to the distance from O to P, and the drum will move from I to J. When it reaches G, the movement is less as shown by the distance, P-Q, and the drum moves from J to K, the same distance as before. As the nut reaches the point H, the movement will be considerably less, as shown by the distance, Q-R, and the carriage moves from K to L, the same distance as in each of the other stages.

During the early stages of the building of the cop, the horizontal movement of the quadrant nut is more uniform and the spindles are run at nearly a uniform speed.

When the carriage starts to run in, from I to J, the horizontal movement of the nut, from C to D, corresponds, nearly, to the movement of the carriage and the spindles run at a comparatively slow speed but as the carriage recedes from the starting point, the horizontal movement of the nut decreases in proportion to the movement of the carriage and the spindles are turned at a proportionately faster speed, by more of the chain unwinding from around the drum.

When the cop reaches its largest diameter, the nut is at its highest point, A, and remains at this point until the cop is finished. The speed of the spindles, at different points for each stretch, is the same.

Reference has been made to the fact of the spindle being larger at the base than at the point, and that some means must be employed to make up for this difference. If this is not done, the noses of the

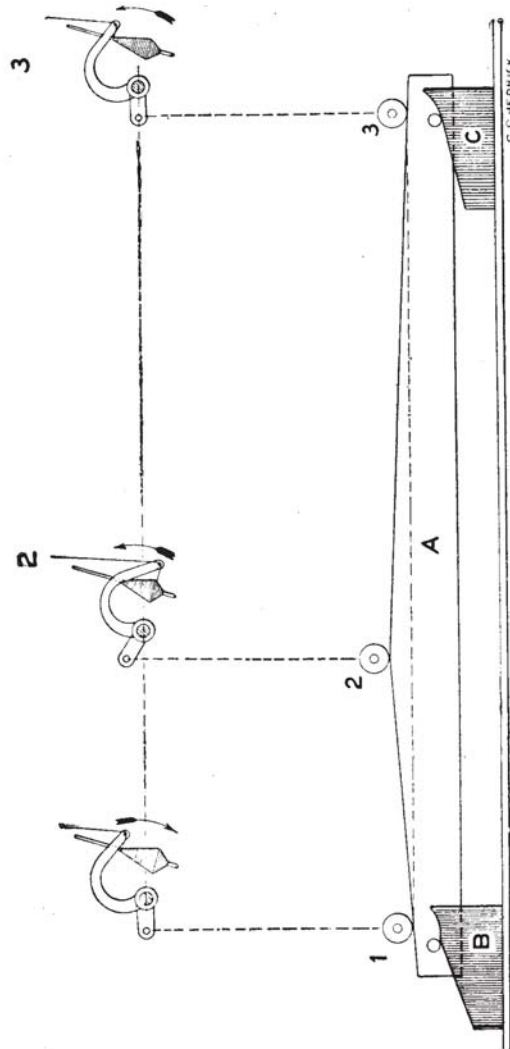

Fig. 237. Diagram Showing Winding.

cops will be soft, caused by slack winding. To overcome this, a device, called the automatic nosing motion, is used.

The winding drum is made with a straight face, for the greater

portion of its length, but terminates in a smaller diameter at the end of which the chain is fastened.

While the first half of the cop is building, the chain unwinds from the straight face of the drum, but as the cop approaches the finish, the chain is gradually shortened by winding around a drum formed on the quadrant nut. This causes the chain to unwind on to the smaller diameter of the winding drum and gives the spindles a few additional turns just as the carriage arrives at the end of the run.

Builder. By referring to Fig. 225, the builder, or copping rail, will be seen to consist of two parts, a main piece, L^3 , and a short piece, O^3 , called the loose incline.

The main piece is supported at the front by the builder shoe, O^4 , and at the back by the shoe, O^{10} . The forward end of the loose incline is supported by the shoe, O^2 . The shoes are connected by the rod, O^4 . At each stretch, the shoes are

moved back, causing the rail to drop a little and the fallers to rise a corresponding distance, thus bringing the winding higher upon the spindles.

Fig. 237 shows the copping rail, A, composed of one piece and supported at each end by shoes, B and C. The fallers are shown above in three positions, 1, 2 and 3.

When winding commences, the faller wire is in the first position but, when the carriage reaches the highest point in the rail, at the second position, the faller wire has descended to the lowest point.

From here to the third position, the faller

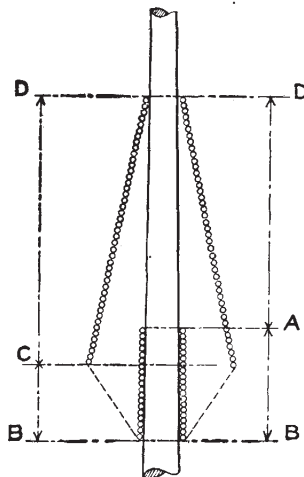

Fig. 238. Diagram of Cop Showing Winding.

rises slowly until it reaches the same height as the starting point. This will cause the yarn to wind on to the spindle, as shown in Fig. 238, by the distance C to D. The distance, C to D, is considerably greater than the distance, A to B, and the finishing point, D, has risen from A to D at a much quicker rate than the commencing, which has moved from B to C, only. It is evident that if the rail is composed of one piece, it will cause all of the layers to be wound the same height.

The way to overcome this is to have a loose incline as shown in Fig. 239.

The builder rail, H, I and J, is made in two pieces, the surface, H-I, is hinged to J at I. By this means, it is possible to lower the points, H and J, as much as is shown by the distance, M, and as these points represent the start and finish of the stretch, it will be seen that the yarn must commence and finish winding at the same point, while the point, I, must fall to a less extent than either the points, J or H, as shown by the distance, L. The distance, L, represents the movement B to C in Fig. 238 and the distance, M, represents the movement A to D.

This continues while the bottom of the cop is building after which the points, H, I and J, fall to the same extent, as the winding gradually approaches the top of the spindle.

When the inward run is finished, the fallers are unlocked. The cam sleeve is given a half revolution and the parts are caused to re-en-

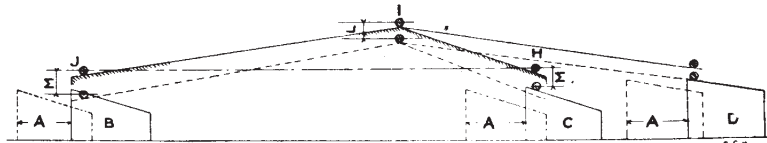

Fig. 239. Diagram Showing Loose Incline.

gage ready to commence the operation of drawing and twisting again. The front roll clutch is put in gear, the drawing-up friction is disengaged and the belt is moved on to the tight pulley.

During the run in, while the front roll clutch is disengaged, the front roll is caused to turn about one revolution, being driven from the carriage shaft by what is called the roller motion, shown in Fig. 240. This consists of a plate, A⁴, keyed to the front roll which carries a pawl, A⁶, held by a spring, A⁷, in contact with teeth formed on the inside of the roller motion gear, A⁵.

When the carriage runs out, the front roll is driven from the twist gear, as already described, but when it runs in, motion is communicated to the front roll, from the carriage shaft, through the gears of twenty-two, fifty and seventy teeth (Fig. 222) by the pawl engaging the teeth of the roller motion gear.

Snarls are produced in yarn in many ways. Following are some causes:

The quadrant nut may be too high.

The fallers may unlock too soon.

The nosing motion may not operate until the cops get too full.

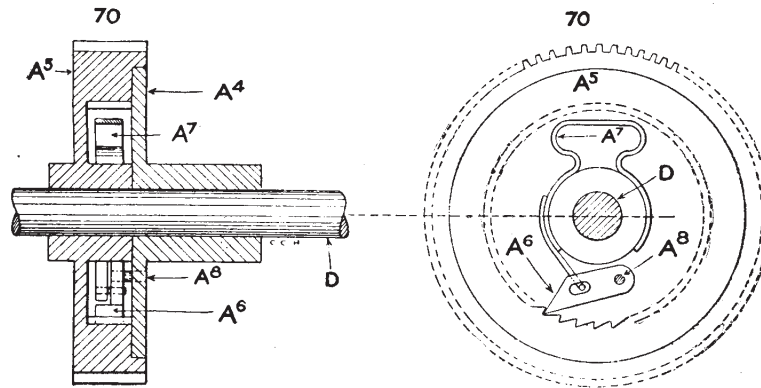

Fig. 240. Roller Motion.

There may not be enough gain in the carriage.

If the counter faller is too high on the outward run, it will lift the yarn from the points of the spindles.

The rim and spindle bands may be too slack.

If the ends are left down too long, snarls will be made, when the end is pieced up, by the cop not being pushed up the spindle.

The snarling motion may not be set correctly.

The bolsters and steps for the spindles may be badly worn.

Uneven roving will cause snarls by winding loosely on some spindles and tightly on others.

Snarling Motion. To overcome snarling of the yarn, the mule is provided with what is called a snarling motion, which is shown in Fig. 241.

Around the loose half of the front roll clutch, J^1 , passes a strap, J^3 , connected to the back end of which is a weight, J^3 ; on the front end is a smaller weight, J^6 . Both parts, J and J^1 , of the clutch are mounted loosely upon the front roll, D . A dog, J^2 , is keyed to the shaft. On the part, J^1 , of the clutch are two lugs which project between the ears of the dog, J^2 .

When the teeth of J^1 are caused to engage with the teeth of J , motion is communicated to the front roll by the lugs on J^1 turning until they come in contact with the ears of the dog. When J^1 turns, the friction of the strap carries the weight, J^5 , up, until it comes in contact with J^1 , where it remains until the end of the outward run

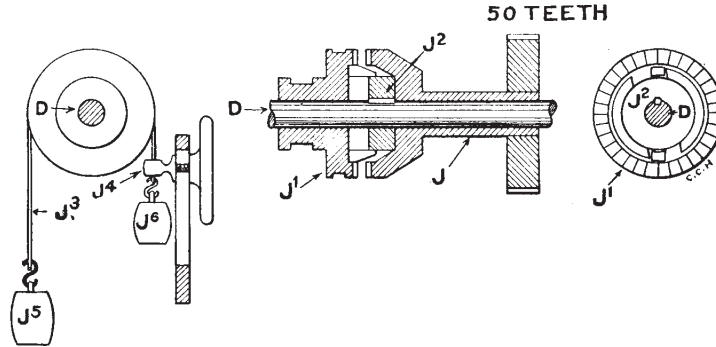

Fig. 241. Snarling Motion.

is reached. When the clutch is thrown out, the part, J^1 , is turned backward by the weight, J^5 , overbalancing J^6 , until the lugs come against the back side of the ears of J^2 . The carriage starts out at the same time that the clutch is thrown in, and, as no movement is given to the front roll until the lugs come against the ears of the carrier, the snarls are taken out of the yarn by the outward movement of the carriage.

REVIEW QUESTIONS.

PRACTICAL TEST QUESTIONS.

In the foregoing sections of this Cyclopedia numerous illustrative examples are worked out in detail in order to show the application of the various methods and principles. Accompanying these are examples for practice which will aid the reader in fixing the principles in mind.

In the following pages are given a large number of test questions and problems which afford a valuable means of testing the reader's knowledge of the subjects treated. They will be found excellent practice for those preparing Civil Service Examinations. In some cases numerical answers are given as a further aid in this work.

REVIEW QUESTIONS

ON THE SUBJECT OF

COTTON FIBER

1. Draw or trace a map of the world, showing the equator, and indicate with dotted lines what you consider the World's Cotton Belt.
2. (a) Name and describe the finest kind of cotton grown.
(b) Why is this better than other varieties?
(c) What cotton most closely resembles wool?
3. Describe the method of cotton cultivation and the general characteristics of the ripe fiber.
4. What are the disadvantages encountered in manufacturing unripe fiber?
5. Into what classes may cotton gins be divided?
6. Describe the principles of each class of cotton gin.
7. If you were the owner of a large quantity of Sea Island seed cotton, by what method would you have it ginned?
8. (a) Can Sea Island cotton ginned by the proper method contain *cut staple*? Explain.
(b) Can it contain *neppy* cotton? Explain.
9. What do you consider the most necessary characteristic of cotton fiber to be used for spinning?
10. What are the important considerations in buying cotton for weft or filling purposes?
11. If you bought 250 bales of cotton (500 pounds per bale) at $9\frac{1}{2}$ cents per pound, and it was discovered that there was

COTTON FIBER.

9 $\frac{3}{4}$ per cent of moisture, what would be the cost per pound to your mill, considering 6 per cent of moisture as being normal?

12. What is the manner of ascertaining the excess of moisture in cotton?

13. In your opinion, why should the bale breaker be used more in England than in the United States?

14. State your reasons for considering that cotton bales of the same variety, grade, and from the same locality, should or should not be mixed.

15. Does the uniformity of length of cotton staple make any difference in the quality of yarn produced? State your reasons.

16. Into what divisions may the life of the cotton plant be divided?

17. Describe the different methods of baling.

18. Of what is an individual cotton fiber composed?

19. How would you determine the amount of sand and dirt contained in a cotton sample?

20. How can *cut staples* be avoided in ginning?

REVIEW QUESTIONS

ON THE SUBJECT OF

COTTON SPINNING

PART I

1. The laps from the intermediate picker weigh 14 ounces per yard; there are four doubled on the apron of the finisher picker which has a draft of $4\frac{1}{2}$; what is the weight per yard of the lap from the finisher?
2. What draft gear would be used to give this draft?
3. What should be the number of teeth in the knock-off gear to wind a lap 50 yards long?
4. If the draft of air produced by the fan on the picker is too strong, what is the result?
5. What advantage is there in using two single-beater machines instead of one two-beater machine?
6. Why is there a difference in the size of the meshes in the top and bottom cages?
7. Describe the device for preventing any foreign substance from being wound into the lap.
8. What two systems are used for regulating the weight of the laps on the intermediate and finisher pickers?
9. What should be the draft of the picker with a draft-gear of 16 teeth?
10. What would be the production of the picker in a day of 10 hours, less 10 per cent. for time lost in cleaning, with a 5"-diameter feed-pulley and a 14-ounce lap?

COTTON SPINNING.

11. What means are provided for preventing the laps from splitting?
12. Into how many and what systems can picking machinery be divided?
13. Which style of beater removes the most dirt?
14. What are the requirements of cotton that is to be spun into fine yarn?
15. What are the foreign substances that are removed from the cotton in the opening and picking processes?
16. Describe the means provided for preventing the dirt in the dust-room from blowing back into the machine that is not in operation.
17. Under what conditions is a blowing system used to the best advantage?
18. Describe how the feed of an automatic feeder is regulated.
19. For what purpose is the dust-room?
20. What system of pickers is used the most at the present time?
21. How fast is the beater of an opener usually run?
22. Under what conditions is a guage box section used on a breaker picker?
23. How is the size of the dust flue determined?
24. Where are the stripping rolls, and what is their purpose?
25. Name the different styles of beaters and tell where each is generally used.
26. How many places are there on a single beater finisher picker for cleaning the cotton?
27. Describe the method of feeding cotton to a picker before the introduction of automatic feeders.

REVIEW QUESTIONS

ON THE SUBJECT OF

COTTON SPINNING

PART II

1. What will be the production of a card per day of ten hours, less 6 per cent of time, lost in stripping and cleaning? Speed of doffer, 13.5 revolutions per minute. Weight of sliver, 62 grains per yard. (Fig. 106.)

2. What gear should be used to give the doffer 13.5 revolutions per minute?

3. What will be the number of points per square foot, in the clothing of the cylinder, if the fillet has 21 noggs per inch?

4. Describe the manner in which the strippings from the flats are regulated.

5. What should be the number of points per square foot for the clothing of the cylinder, doffer and flats on a card for medium work?

6. Describe the operation of stripping the card.

7. What would be the draft of the card to make a sliver weighing 49 grains per yard from a lap weighing 12.5 ounces per yard with 4.5 per cent loss in weight from stripping, dirt, etc.?

8. Explain why a screen is necessary under the card cylinder.

9. What is the object of the flats?

10. Why is it better to have a separate pulley for driving each card?

11. Give the usual settings required on the card.

12. Describe the operation of grinding the cylinder and doffer.

COTTON SPINNING.

13. For what purpose is the mote knife?
14. What are the defects in the feed rolls of the old style cards?
15. How often is it necessary to grind the card?
16. Name some of the defects liable to be found in card clothing.
17. What effect does oil have on the foundation of card clothing?
18. Of what is the foundation for the clothing of the flats generally composed?
19. Theoretically, what position is considered best for grinding the flats?
20. What evils are caused by the stretching of the flat chain?
21. Describe the covering for a Stripping Brush.
22. What are the advantages of a Calendar Roll Stop Motion?
23. What kind of wire is used for Card Clothing on a Revolving Flat Card?
24. What should be the draft of the Card, shown in Fig. 103, with a draft gear of 16 teeth?
25. What pressure is used when drawing on the fillet for a Cylinder and a Doffer?
26. What should be the speed of the doffer of the Card, shown in Fig. 104, with a change gear of 23 teeth?
27. What part of the card wire is called the crown?
28. What would be the production of the Card, shown in Fig. 105, for a day of eleven hours, less 5 per cent? Weight of Sliver, 58 grains. Change Gear, 19 teeth.
29. What gear should be used to give 109 draft for the Card, shown in Fig. 103?
30. What would be the draft of the Card, shown in Fig. 104, to make a sliver weighing 56 grains per yard, from a lap weighing 14 ounces per yard, less 6 per cent. loss in weight for dirt, strippings, etc.?

REVIEW QUESTIONS

ON THE SUBJECT OF

COTTON SPINNING

PART III

1. What will be the production of the comb per day of ten hours, less 10 per cent? Weight of laps, 230 grains per yard; number of laps, 6; percentage of waste, 18; revolutions of cylinder per minute, 75; draft of comb, 22.5.

2. Name the different ways in which combing machines are arranged.

3. What gear should be used to give the comb a draft of 22.5?

4. What are the stopmotions on the ribbon lapper called, and why are they necessary?

5. What will be the weight per yard of the lap from the sliver lap machine? Slivers, 47.5 grains per yard; double, 14; draft, 2.25.

6. Name some of the uses for combed yarns.

7. Calculate the draft factor for the ribbon lapper from the diagram of the gearing shown in Fig. 111.

8. Describe the manner in which the feed rolls of the comb are driven.

9. What will be the weight in grains per yard of the lap from the ribbon lapper? Laps at back, 295.55 grains per yard; double, 6; draft, 6.15.

10. For what purpose is the timing dial of the comb?

11. What will be the weight of the comb sliver in grains per yard? Weight of laps, 250 grains per yard; double, 6; draft, 27; percentage of waste, 20.

12. What is the usual draft of the sliver lap machine?

13. What will be the production of the sliver lap machine for a day of eleven hours, less 10 per cent? Weight of lap, 260 grains per yard. Calender rolls make 72 revolutions per minute.

COTTON SPINNING

14. What are the functions of the cushion plate and the nipper knife?
15. What is the draft between the front roll and the 5"-diameter calender roll, on the ribbon lapper gearing shown in Fig. 111?
16. Explain why a balance wheel is necessary on the driving shaft of the comb.
Double on sliver lap machine, 14; draft of sliver lap machine, 2.6.
Double on ribbon lapper, 6; draft of ribbon lapper, 6.2.
Double on comb, 6; draft of comb, 26.
Percentage of waste, 16.
18. For what purpose are the detaching rolls, and how are they operated?
19. What will be the production of sixteen combs per day of ten hours, less 11 per cent? Speed of cylinders, 78 revolutions per minute. For weight of sliver, take result of calculation in Question 17.
20. Describe how the percentage of waste may be controlled by the top comb.
21. What will be the draft of the sliver lap machine with a draft gear of 49 teeth?
22. What part of the cylinder is called the half-lap, and how is it constructed?
23. For what purpose is the lifting cam?
24. How are the top combs operated?
25. Describe the manner in which the cylinders are set.
26. Describe how the percentage of waste may be controlled by the feed rolls.
27. If the nippers are late in closing, what is the result?
28. What are the necessary characteristics of yarn for hosiery and underwear?
29. What is the width of the lap made on the sliver lap machine?
30. What will be the revolutions of the driving pulleys on the ribbon lapper to give the 5"-diameter calender rolls 85 revolutions per minute?

REVIEW QUESTIONS

ON THE SUBJECT OF

COTTON SPINNING

PART IV

1. Name the fly frame change gears and state for what purpose each is used.
2. What is the standard twist for 8.25 hank roving?
3. Describe the conditions that affect the tension gear.
4. What draft will be required on a fine fly frame to make 6.50 hank roving from 2.18 hank in the creels?
5. What should be the number of teeth in the twist gear to give the twist per inch called for in Problem 2?
6. What will be the number of roving spun, with a draft gear of 25 teeth, from 3.00 hank in the creel of the machine?
7. Describe the difference between "flyer lead" and "bobbin lead."
8. State the reason for weighing 12 yards of roving when it is desired to ascertain the hank.
9. For what purpose is the differential gearing?
10. Give the reason for changing the cone gear.
11. If 12 yards of roving weigh 94 grains, what is the hank?
12. What will be the production for a day of 10 hours for a fine fly frame making 6.50 hank roving?
13. State why the weather or atmospheric conditions affect the building of the bobbin.
14. What is the weight in grains per yard for .63 hank roving?
15. What will be the draft of the fine fly frame with a 36 tooth draft gear and a front roll gear of 47 teeth?

REVIEW QUESTIONS

ON THE SUBJECT OF

COTTON SPINNING

PART V.

1. How many yards will there be in one pound of Number 39 yarn?
2. Why is the rail made to traverse faster in one direction than in the other, on a filling wind?
3. Find the production per spindle for a day of ten hours for Number 30 filling yarn, standard twist. Speed of spindles, 8600 R. P. M. Estimate of time run, 580 minutes.
4. What twist gear is necessary to give the twist called for in question 3?
5. Figure the draft factor with a crown gear of 104 teeth and a front roll gear of 30 teeth.
6. Figure a program for making Number 24 warp yarn with three processes of roving; picker lap to weigh 14 ounces per yard and double roving in spinning creel.
7. What is the weight per yard for Number $7\frac{3}{4}$ yarn?
8. Find the draft factor for the mule from the diagram of gearing shown in Fig. 223.
9. What should be the number of the hank roving, doubled in the creel, to spin Number 60 yarn with a draft of 12?
10. Figure the twist factor for the ring frame with a drum gear of 24 teeth and a front roll gear of 91 teeth. Drum 8 inches in diameter; whirl $1\frac{3}{8}$ inches in diameter; and front roll $1\frac{1}{8}$ inches in diameter.
11. What is the standard twist for Number $67\frac{1}{2}$ filling yarn?
12. What should be the number of teeth in the twist gear for Number 30 warp yarn, standard twist, using the factor found in question 10?