

The Chinese have long been celebrated for the beauty of their embroideries; indeed, it has been doubted whether the art was not originally brought into Europe from them, through the Persians. They use floss and twisted silks, also the bark of a tree spun into a fine thread.\* The drawing of their embroideries is sometimes as uncouth as that of their paintings, but in that of some of their flowers (doubtless copied from nature) they are frequently even botanically correct; and their works are not more to be admired for their remarkable freshness than for the extreme labour bestowed upon them. Success, as gained by patient application, is nowhere so frequently exemplified as in China. The mere accomplishment of writing a good style, is the result only of many tedious years of study and self-denial. The beauty of the written character, the finished graces of their composition the excellence of their silk manufactures and embroidery, the wonders of their porcelain, and many other marvels in art and knowledge, are the natural results of untiring industry and perseverance. A Chinese uses no short cuts, resorts to no compendious methods for abridging labour:— he is not without ingenious resources to accomplish an end, but his aim does not seem to be to save time.

We are indebted to Mr. Tradescant Lay for the following interesting account of the art of embroidery as at present practised by the Chinese. "For twenty-two cash or tseen," he says, "I purchased an elegant book, filled with choice subjects of the graphic art, as patterns for the use of the young needlewoman. She is assumed to be poor, and hence the little manual is priced at about one penny of our money. It has a cover of a fair yellow, studded with spangles of gold, and contains between two and three hundred figures, culled from the varied stores of nature and art. In fact, the objects are so well selected and so numerous, that they might serve as illustrations to a small encyclopedia. One acquainted with Chinese literature and natural history, might deliver several lectures with this book before him. The meadow, the grove, the brook, the antiquary's museum, and the pages of mythology with the adornments of the house and garden, are all laid under contribution.

---

*limbularii*. According to Du Cange, they anciently wrote *aurobrustus*, for embroidered with gold, or *brustus brodatus*, whence the French word *broderie*.

\* The fine muslins made at Manilla, with threads spun from the pine-apple plant, and afterwards so richly and delicately embroidered with the same material, are well known.

The book is said to be for the use of the person who belongs to the *green window*, which is an epithet for the dwelling of a poor woman: while the *red gallery* denotes the residence of a rich female. The industrious poor plies her task near the green lattice, which is made of earthenware, and lets in both the light and the breath of heaven; while the rich dame leans upon the vermil-tinted balusters of the gaudy verandah, and gazes carelessly at the sunbeams as they sparkle among the flowers or woos the soft breeze which agitates the green roof of the Indian fig-tree. The title-page presents us with a venerable man, in the weeds of office, holding in his hand a scroll with this motto, 'Heaven's magistrate confers wealth.' Over his head are bats disporting among the clouds; the emblems, I suppose, of wakefulness, for these animals are on the alert, while men sleep. 'Her candle goeth not out by night,' is what Solomon tells us of the needle woman, whom he eulogizes in the last chapter of Proverbs. I once saw two girls at this work in the village of Mongha. They were seated upon a low stool, and extended their legs across another of twice the height of their seat. In this way a support was provided for the frame on which the piece to be embroidered was spread forth. Their faces wore a sickly hue, which was owing, perhaps, to close confinement and the unnatural position in which they were obliged to sit. The finest specimens of embroidery are, as far as my observation goes, done by men, who stand while at work—a practice which these damsels could not imitate, as their feet were small. They were poor, but too genteel, in their parents' idea, to do the drudgery of the humble housewife, and so their feet were bandaged and kept from growing beyond the limits of gentility. Their looks were not likely soon to attract a lover, and hence they were compelled to tease the sampler from the glistening dawn till the dewy eve. Much skill and labour are bestowed on the embroidery of a plaited skirt worn by ladies, which, with my partiality for what is Chinese, I think without a rival for beauty as an article of female attire. In the little work before me, several patterns are given expressly for this purpose. A curious purse worn in the girdle of Chinese gentlemen, is also the subject of much of this kind of elaboration. Embroidery and figured textures were generally in favour with the ancients, so that the discovery was thought worthy of a superior agency. In the Old Testament we have two kinds, the *maase rokem*, (*opus phrygionicum*), in which the figures were inserted by the needle; and the *maase choseb*, (*opus plumarium*), in which they were wrought in the web. The Chinese are fond of retaining what is

old, and have preserved both these arts in their highest state of perfection."

The beautiful embroideries on muslin, with cotton, by the Indian and Candian women, are well known. The embroidery practised by the latter is curious enough: they work with their own hair, as well as that of animals, with which they make splendid representations of flowers, foliage, &c.: they also insert the skins of eels, sea serpents, banshees, mermaids, and other *outlandish* kinds of fish.

According to M. de Busson, the negresses of Senegal, before their marriage, embroider the skins of various beasts, representing figures, flowers, and animals, in every variety of colour; and the pictures thus formed, they present as trophies of their skill to their husbands, on the morning (before sunrise) of the *ninth* day after marriage: this curious custom appears to be almost universal among the *lower orders*, but it is not so prevalent in the *refined circles*.

The Georgians and particularly the Turkish women, are renowned for their embroideries on the lightest and most delicate materials, such as crape and gauze, which they ornament with gold thread in a manner unequalled. Their embroideries on morocco leather have long been esteemed, on which they work the smallest objects in *gold passing*, without fraying the thread, in a way we cannot imitate. According to M. Savary, they formerly often ornamented their embroidery with pieces of money, the value of which they did not appear to understand; a circumstance, however, which the Genoese merchants, who had a considerable trade in the Levant, turned greatly to their advantage, as valuable and interesting coins and medals were frequently found in the old garments in which they sometimes trafficked. Besides the Turks, the Greek women of the present day, and the inhabitants of the islands of the Levant, are still celebrated for their embroidery, principally of gold and silver. The women of Therapia on the Bosphorus excel in a most beautiful description of work; it can scarcely, however, be termed embroidery, being rather a species of exquisitely fine netting. They represent flowers in relief, every petal of which is worked with the utmost exactness. These extraordinary productions of the needle, unfortunately but little known in this country, cannot be sufficiently admired for their extreme delicacy and elaborateness.

In the last and preceding centuries, when embroidery, as an article of dress both for men and women, was an object of considerable importance, the Germans, but more particularly those of Vienna,

disputed the palm of excellence with the French. At the same period, Milan and Venice were also celebrated for their embroidery; but the prices were so extravagantly high, that according to Lamarre, its use was forbidden by sumptuary laws.

The art of embroidery seems to have attained a higher degree of perfection in France, than in any other country;—it is not, however, so much practised at the present day. Embroiderers formerly composed a great portion of the working population of the largest towns; laws were specially framed for their protection, some of which would astonish the work-people of the present day. They were formed into a company as early as 1272, by Etienne Boileau, Prévot de Paris, under their respective names of “Brodours, Découpeurs, Egratigneurs, Chasubiters;”—their last statutes were framed in 1719.

In Saxony, embroidery on fine muslin and cambric has been carried to great perfection. In the neighbourhood of Ebenstock, and the Erzgebirge, much tambour work is done; this is generally sold at the Leipzig fairs, where it is bought by the Russian and West Indian merchants; great quantities are also exported to Persia. At Plauen, in the same neighbourhood (celebrated for its manufactures in linen, cotton, and muslin,) much figured lace is also worked, which may be met with at the shops in Dresden. The embroideries of Nancy and Paris of this description, have of late years attained great excellence, and are much sought after.

Embroidery, on an extensive scale, is often effected in the Jacquard and draw looms. In such cases, front headles are employed; and two beats or strokes of the reed are given to each thread of weft thrown across the web. When there are several colours in one line of the pattern, (as in Fig. 70,) there must be one card or lash to each, to enable the weaver or weavers to embroider them, one colour after another; which he does before giving the two ground beats or strokes of the reed. Embroidered fabrics for covering furniture, are always worked with front headles, for the purpose of binding the embroidery, and the threads of warp which pass through these headles are sometimes taken from the ground warp, and sometimes from an extra warp, accordingly as it happens that the embroidering shades are the same as those of the ground warp, or different from them. Small shuttles or pirns (sometimes called *circles*) are used; a correct representation of one of which is given at Fig. 136. The ground headles are worked for the ground strokes, and the binding headles only are used for embroidering. In most



instances the weaver works the ground headles with his right foot, (as in damask weaving,) and the binding headles with his left. When the pattern requires a great variety of shades of colour, the workman places the design paper before him, (as in Gobelins tapestry weaving,) so as to see distinctly how to insert them. When there is any gilding of gold or silver used in embroidering, (which is often the case,) the cloth must be carefully rolled in paper, as fast as woven, to prevent the gilding from injuring the cloth: this is effected by putting clean paper between the cloth and the roller on which it is wound. Each colour in the pattern requires a shuttle for each repeat in the breadth of the web, so that the whole number of shuttles employed is often very considerable. The embroidering shuttle or pirn is generally about  $1\frac{1}{8}$  inches in diameter, and  $\frac{2}{3}$ ths of an inch thick, with a hole in its centre, (as in Fig. 136,) for the carriage pin on which it revolves, as fast as the thread is wanted: its inside is hollowed out to about  $\frac{1}{4}$ ths of its whole diameter to receive the warp.\*

It would have been supposed, that embroidery could never have been worked with profit by machinery; yet, such is the case. But a few years since, M. Josué Heilmann, of Mulhausen, France, invented a machine by which a female, with the assistance of two children, could turn off daily as much work as 20 expert hand embroiderers, employed upon the common frame. An account of this remarkable invention will, therefore, be interesting to many of our readers.

Mr. H. exhibited his embroidering machine in Paris, at the "National Exposition of the Products of Industry," for 1834; and of all the specimens of ingenuity there displayed, it was, without doubt, that which attracted most attention, for whether at rest or in motion, it was always surrounded by a crowd of curious persons; some directing their attention to the embroideries which it had executed, and others trying to follow its motions and to divine its mechanism. Indeed, it was interesting to see, in a small compass, 130 embroidering needles, each busied in copying the pattern, and accomplishing its task with perfect regularity; one person only being required to put all these needles into action. The spectator was especially struck with admiration, in seeing the precision with which each of the needles came of itself to prick the stuff in the very place where the most expert hand would have done it!

Mr. Heilmann has, in the construction of this machine, overcome, in a mechanical point of view, difficulties of an almost in-

---

\* In some instances, the common shawl shuttle is used instead of the circle.

surmountable character ; and he well merits the compliments which he has received.

It is not necessary that we should enlarge upon the national advantages which must result from this invention, because, they will appear obvious to every reflecting mind. We would remark, however, that it is calculated to supply us with beautiful embroideries, for home consumption, at least, and render us independent of foreigners in this delightful branch of industry, saving millions of dollars annually to the country.

*Mulhausen, August 5th. 1843.*

Dear friend,

Your favour of the 29th June last has just reached me, enclosing a Copy of "Ure's Dictionary of Arts, Manufactures and Mines ;" in which publication, at page 437 of vol. 1, a catch-penny description of my Embroidering Machine is given : but as all the movements and mechanical arrangements contained in plate 2, of your drawings, with many essential parts of plate 1, are omitted, I have come to the conclusion that the Doctor's description is not intended to benefit the manufacturer or mechanician, in a *practical point of view*, but only for the amusement of children.

I am glad to hear that you have embarked in the publication of a treatise on the art of weaving, which will include all its various branches. Such a work, I am persuaded, will prove of immense benefit, not only to individual manufacturers and weavers, but also to your own country and the world at large ; for in this age of charlatanism, when effrontery usurps the place of genius, a real practical work like that you name, will be quite a god-send ; and you have my best wishes, with those of your friends here, in the undertaking.

" Facts truly stated are the best applauses, or the most lasting reproaches."

I have not made any improvement on the Embroidering Machine for some time past ; nor has there been any material alteration made in its principles, so far as I am aware, either here or in England, since its first introduction.

The patents obtained in France and England, have expired but a short time since, so that this invention, which has really procured me many compliments (among which is the decoration of the "*Légion d' Honneur*") is at present public property.

During the course of last year, I several times visited the factory of Mr. Louis Schwabe, of Manchester, containing 15 of my Embroidering Machines. This manufacturer has received compliments at least sufficient to drive a man crazy, (*Ce manufacturier a recuilli des compliments, à faire tourner la tête,*) from a multitude of persons, who were in Manchester last year, at the meeting of the British Association.\*

Although this invention has filled the mechanical world with wonder, I do not think that it has turned much to the pecuniary advantage of those who have hitherto adopted the use of it; but my opinion is, that it will be more serviceable when within the reach of every one.

When your work on the "manufacture of textile fabrics" is ready, you would do well to send a copy of it to our *Société Industrielle* here. It would certainly be received with much favour; and, perhaps, might prove greatly to your advantage.

Je vous présente mes salutations cordial

JOSUÉ HEILMANN,

Membre de la Legion d' Honneur.

MONS. C. G. GILROY,

à New York,

Etats Unis d' Amerique.

The price of a machine containing 130 needles, and of course, 260 pincers or fingers to lay hold of them, is 5000 francs (nearly 1000 dollars.) Each machine, as before observed, is calculated to perform daily the work of 20 expert hand embroiderers; and it requires merely the labour of one adult, and two assistant children.

The operator must be well instructed in the use of the machine, for he has many things to attend to at the same time: with one hand, he follows the drawings with the point of the pantograph; with the other, he turns a handle, to prick and draw all the needles, which are held fast in pincers, and carried by carriages, approaching to and receding from the web, rolling all the time along an iron railway; and lastly, by means of two pedals or treadles, on which he bears alternately, with one foot and then the other, he opens the 130 pincers of the first carriage, which must give up the needles after having pricked them into the stuff, and he shuts at the same

---

\* We think these compliments have been altogether misplaced. Would it not have been more becoming in these gentlemen, to have sent Mr. Heilmann, the inventor of the machine, a handsome gold medal, in token of their admiration of his ingenuity?

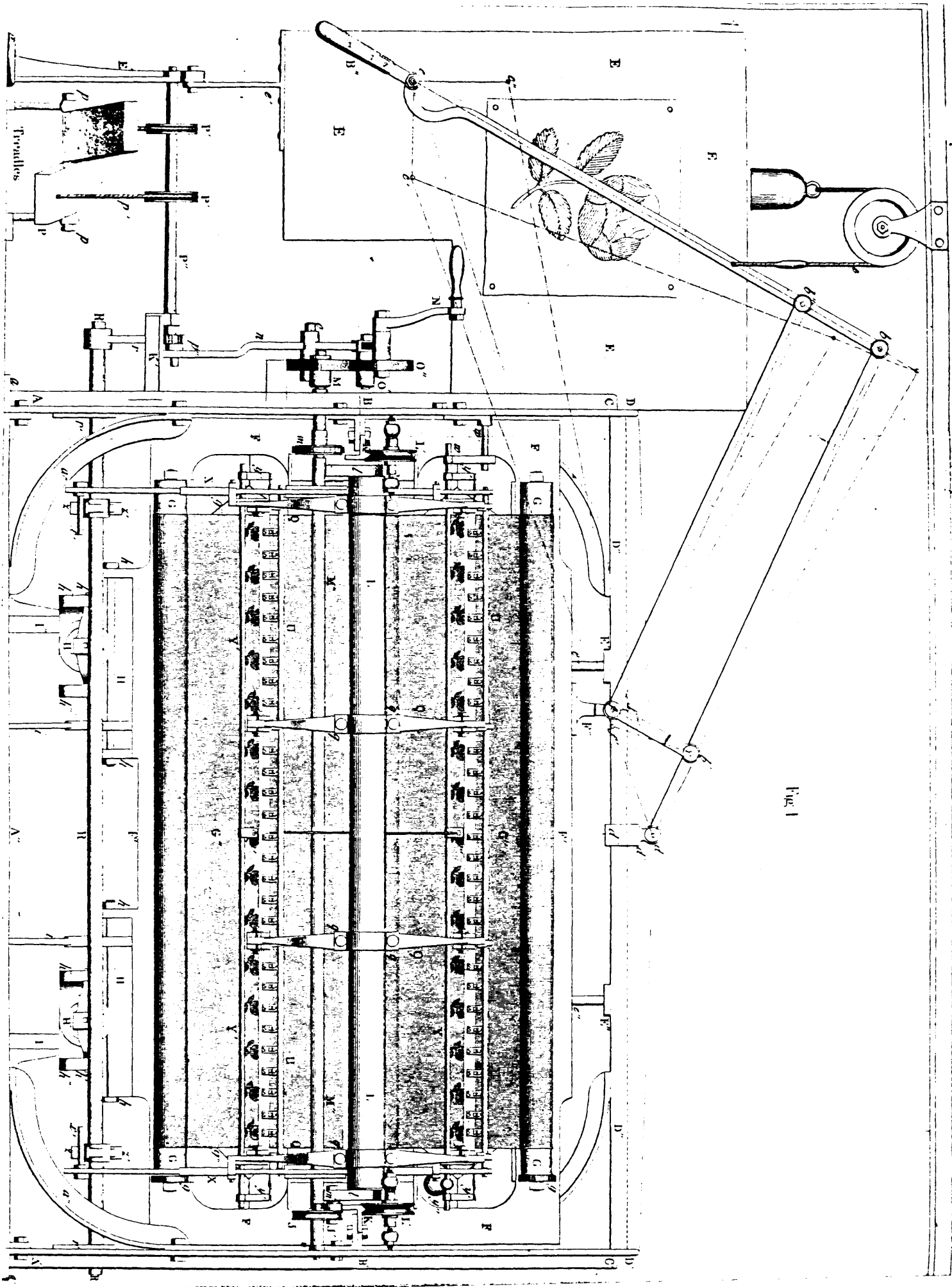
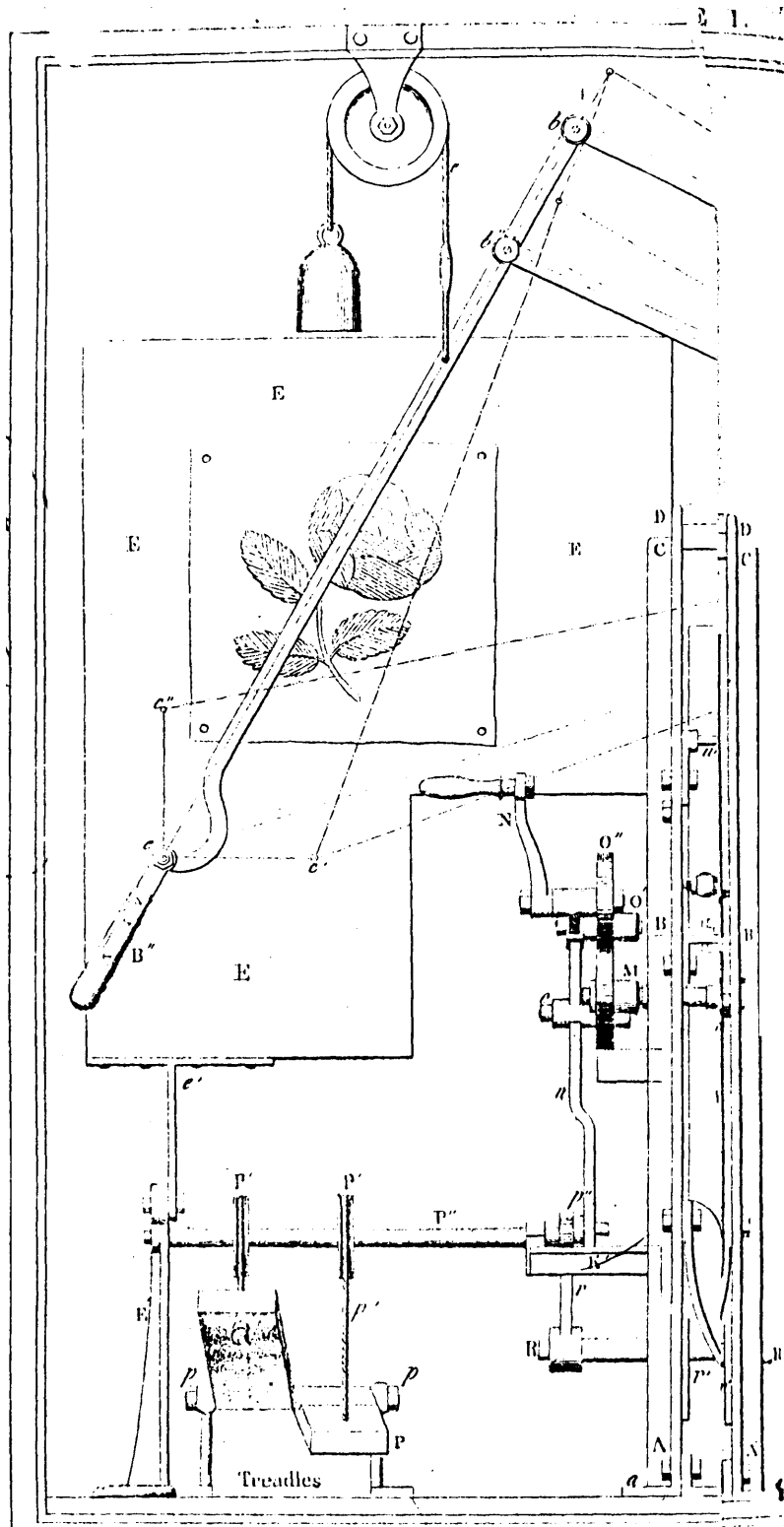

Fig. 1



time the 130 pincers of the second carriage, which must receive them and draw them back afterwards. The children have nothing else to do, but to change the needles when the threads are used up, and to watch that no needle misses its pincers.

We shall endeavour to make all the details of this machine perfectly understood ; because, it is not less remarkable for the arrangement of the parts which compose it, than for the effects produced.

We shall describe successively,

- 1st. The arrangement of the frame,
- 2nd. The arrangement of the stuff,
- 3rd. The arrangement of the carriages,
- 4th. The arrangement of the pincers.

#### ARRANGEMENT OF THE FRAME.

The frame is of cast iron ; the parts must be strongly fixed together and set on a foundation firm enough not to be shaken, either by the motion of the machine itself or the movements of the girls, who go from one pincer to another to change or fix the needles. Fig. 1, represents an elevation taken in front of the machine, and Fig. 2, an elevation taken from the left hand side of the machine (as you stand in front of Fig. 1.) In Fig. 2, the side of the frame forms two equal rectangles  $ABBA$ ,  $ABBA$ , symmetrically placed, one at the right, the other at the left hand (as you stand at the side of the machine), and united in the middle by a third rectangle, narrower and more elevated,  $ADCA$ .\* This assemblage of the three rectangles, forms but one piece or casting ; † the sections of the horizontal and vertical sides of the machine are quite similar : on the right hand side at No. 1 (plate 2) is shown a section of the frame, and below it, is represented one of the feet  $a$ , which has a hole to receive a fastening screw, by which it is secured to the ground. The other side of the frame, which is not represented in

---

\* If the reader will carefully examine the central or middle rectangle (of Fig. 2) he will find that it presents a complete edge view in elevation of the left hand side of Fig. 1, being that side on which the machine is worked, as the position of the pantograph denotes ; the letters of reference in the edge or central rectangle Fig. 2, correspond to those of the pantograph or left side of Fig. 1.

† It would be desirable to cast the sides of the frame in one complete piece, as it would save much labor in the fitting up.

the figure, is entirely similar; we shall designate corresponding parts by the same letters of reference with an accent: thus,  $A' B' B' A'$ ,  $A' B' B' A'$ , will be the two symmetrical rectangles of the second end of the frame,  $A' D' C' A'$  will be the rectangle of the middle, corresponding to  $A D C A$ , and  $a'$  will represent the six feet (see Fig. 2) corresponding to those designated by  $a$ . Between each foot and its correspondent  $a'$  there is a bar of cast iron  $A''$ , the form and disposition of which is shown in Fig. 1. Thus, at the under part, the two sides of the frame are joined by six bars, similar to the bar  $A''$ ; besides, at the two extremities of each of these bars, there are knees  $a''$ , to give strength to the frame, two of these knees are shown in Fig. 1: at their upper part, the two sides of the frame are joined by a single bar  $D''$  (Fig. 1,) which has the form of a trough; and is fastened by a nut and screw to the corresponding angles  $D$  and  $D'$ . Fig. 3 represents at its upper part a section of this bar; Fig. 1, shows the form of its outer edge, as well as that of its back, which is represented by a dotted line.

Such is the disposition of the frame, which bears all the mechanism of the machine; and it is necessary to possess an exact idea of it, in order to understand how the other fixed parts are supported; and how the moveable parts, which are here very numerous, are enabled to perform their respective functions with perfect regularity.

The width of the machine depends upon the number of pincers intended to be set to work. The model which we saw at the exhibition in Paris, contained 260 pincers, and was  $2\frac{1}{2}$  metres wide (about 8 feet 4 inches of our measure.) The figures here given have been narrowed considerably, but the other proportions are not disturbed. In our drawings (Figs 1 and 2) the bars  $A''$  and  $D''$ , which connect the sides of the frame  $A$  and  $A'$  together (see Fig. 1) instead of being  $2\frac{1}{2}$  metres long, are not quite 2 metres, (see scale at foot of Fig. 2.)

The length of the frame must always be the same, whether the machine be wide or narrow, for the length of the thread that can be put in the needles, depends upon the length; and it is always advantageous to give the frame, as we have done, all the length adopted by M. Heilmann, that is to say, a little more than two metres, so that the needles might bear a thread one metre long.

#### ARRANGEMENT OF THE STUFF TO BE EMBROIDERED.

We have already observed that the pincers which carry the needles, present themselves always at the same point, and that con-

sequently, the needles would pass and repass continually through the same hole, if the stuff was not displaced with a precision, sufficient to present successively, opposite the point of the needle, all the points through which the needle has to pass, to execute the flower or the drawings intended. The disposition of the stuff and the mechanism by which it is displaced, to the requisite extent, after the needle has gone through, are therefore of great importance, and we shall try to explain them.

The stuff is set on a large rectangular frame, the four sides of which are visible in Fig. 1, viz: the two vertical sides at F, F'; and the two horizontal sides, the upper and the under, at F'', F'''.

Fig. 1, shows also two long wooden rollers G, G', the extremities of which, fastened with iron trunnions, bear on the sides F' of the frame, on which they turn. These two rollers form a *system of beams*, on which the stuff destined to be embroidered, may be rolled and stretched vertically to the proper degree, for each of these beams has at one of its extremities a little ratchet wheel *g, g'*; the teeth of one of these wheels being bent in a contrary direction to the teeth of the other, as indicated in Fig. 3, it follows, that in raising, for instance, the catch of the upper wheel and turning the beam in the direction indicated by the arrow, the stuff draws the under beam and tends to make it turn, whilst the catch of its ratchet wheel holds it, and the stuff G'' (see Figs. 1 and 3) stretches more and more; the same result would be produced by turning the under beam, after having raised its catch. When it is desired to pass any part of the stuff from one of the beams to the other, it suffices to raise at the same time the two catches and to turn in the proper direction the beam on which the stuff is wanted to be rolled, and to let the catch of the other beam drop; then it remains only to stretch the stuff.

Besides this system of under beams, there is a second system of two upper beams, for the same purpose, and which is disposed exactly in the same manner; it is also represented in Fig. 3, but it is not completely seen in Fig. 1, where it is hidden in part by some other pieces.

Supposing that one of these systems presents the stuff to the upper needles, and the other to the under: as the two beams of each system have not their axes in the same vertical plane, the plane of the stuff G'' (Fig. 3) would be inclined and would come to present itself obliquely to the needles, if the workman did not take care to put it straight, and bring it back exactly in the middle, by means of a strong wooden ruler, fixed, as well as the rollers, on



the two vertical sides of the frame ; this ruler is shown at G', Fig. 3, for each of the systems of beams.

The stuff must also receive a lateral tension, in the two opposite directions, and to effect this without its being torn, the operator sews on its edges, little ribbands of linen cloth or other suitable material, and afterwards ties to these ribbands, strings  $g''$  (Fig. 1) which draw them laterally and which are fixed to the sides F of the frame.

It remains to see now, by what ingenious means, the frame may be displaced in all directions, without deviating from the vertical plane in which it had at first been fixed, and how the stuff which is fastened on it, and consequently forced to follow all its movements, may present opposite each needle, the successive points which must be pricked and crossed by the thread.

Mr. Heilmann, to obtain this result, uses the pantograph, by means of which he is enabled to reduce or extend, in fixed proportions, drawings of all kinds. Every one knows the principles on which this instrument is founded, and we shall only recall them to memory in a few words:  $b b' f b''$  (Fig. 1) represents a parallelogram whose four angles  $b, b', f, b''$ , are hinged, and so disposed as to become either very acute or very obtuse, the sides keeping always the same length; the sides  $b b'$ , and  $b b''$ , are lengthened, one to the point  $d$ , and the other to the point  $c$ , and these points  $c$ , and  $d$ , are chosen, on condition that in one of the positions of the parallelogram, the line  $c d$  which joins them, will pass through the point  $f$ ; this condition can be fulfilled in many ways, since the position of the parallelogram remaining the same, it is evident, that in order to carry the point  $d$  further from the point  $b'$ , it would suffice to bring properly the point  $c$  to the point  $b''$ , or *vice versa*; but when the distance  $b' d$  has been once chosen, the distance  $b'' c$ , is a necessary consequence. Now, the principle on which the construction of the pantograph rests is this: it is sufficient that the three points  $d, f$  and  $c$ , be in a straight line in only one of the positions of the parallelogram, to have them to remain always in a straight line, whatever its position be.

For, since in the present position, the line  $c d$  passes through the point  $f$ , the triangles  $b' d f$  and  $b'' c f$  are similar, as having equal angles; for  $b' f$  being parallel to  $b'' c$ , and  $b' d$  to  $b'' f$ , the three angles of the first of these triangles are equal respectively to the three angles of the second; we have then the proportion

$$\frac{b'' c}{b'' f} = \frac{b' f}{b' d}$$

but, in all the positions that the parallelogram may take, in opening or shutting arbitrarily the angle  $b$ , the sides will remain parallel, since the figure will still be a parallelogram; the angle  $c b' f$  will then remain equal to the angle  $d b' f$ , and consequently, if in any other position, the point  $c$  be joined to the point  $f$  and the point  $d$  to the same  $f$ , the two triangles  $b'' c f$  and  $b' f d$  which will result from it, will still have an equal angle comprised within two proportional sides; thus they will be similar, and the two lines  $c f$  and  $f d$  will be on the same line, that is to say, the three points  $c$ ,  $f$  and  $d$  will remain in a straight line.

This once admitted, suppose that we move the point  $c$ , in a certain direction, in making all the system turn round the point  $d$ ; let us imagine, for instance, that the point  $c$  comes in  $c'$ : then, in joining  $d$  to  $c'$ , it is evident that the point  $f$  will be found somewhere on that line  $d c'$ , in  $f'$ , for instance, since it falls always on the straight line, which joins the point  $d$  to any position which the point  $c$  may take.

We have seen, besides, that the new triangles formed on  $d c'$ , (and analogous to the triangles  $b'' c f$  and  $b' f d$  of the primitive position) are similar, and since the lengths  $c b''$  and  $b'' f$ ,  $d b'$ , and  $b' f$ , are constant, we have:

$$\frac{c' f'}{d f'} = \frac{b'' c}{b' f};$$

in the primitive position we had

$$\frac{c f}{d f} = \frac{b'' c}{b' f};$$

it follows then

$$\frac{c f}{d f} = \frac{c' f'}{d f'};$$

the result is, that the line  $f f'$  is parallel to  $c c'$ .

The same thing will happen, when the point  $c$  passes into another point  $c''$ : the point  $f$  will pass at the same time, into another point  $f''$ , and the lines  $f f''$ ,  $f' f''$ , will be respectively parallel to the lines  $c c''$ ,  $c' c''$ ; then, lastly, the figures described by the point  $f$  in the diverse positions of the parallelogram, are always exactly similar to the figures described by the point  $c$ .

To find, now, the relation which exists between the outlines of these figures, it is sufficient to observe, that in the primitive triangles  $b'' c f$  and  $b' f d$ , we have:

$$\frac{cf}{df} = \frac{b''c}{bf};$$

hence

$$\frac{cf+df}{df} = \frac{b''c+b'f}{b'f},$$

but

$$cf+df=dc, \text{ and } b''c+b'f=bc;$$

thus

$$\frac{dc}{df} = \frac{bc}{b'f};$$

the triangles  $df f'$  and  $d c c'$  being similar, we have also

$$\frac{c c'}{f f'} = \frac{dc}{df};$$

hence it results

$$\frac{c c'}{f f'} = \frac{bc}{b'f} \text{ or } \frac{bc}{b b''}.$$

If the side  $b b''$  has been made equal to the sixth part of  $bc$ ,  $f f'$  will be also  $\frac{1}{6}$  of  $c c'$ , that is to say, that in general the outlines described by the point  $f$  will be exactly the sixth part of the outlines described by the point  $c$ .

This proposition is that adopted by Mr. Heilmann.

It may also be observed, that the triangles  $d b c$  and  $d b' f$  being also similar triangles, we have

$$\frac{bc}{b'f} = \frac{db}{db'};$$

and as Mr. Heilmann has taken  $b'd = b'f$ , it results

$$bc = bd.$$

After this demonstration, which requires only the first notions of geometry, to be understood, it will be very easy to perceive how the pantograph acts in the embroidering machine. In looking over Figs. 1, 2 and 3, it will be seen in Fig. 1, that the side  $bc$  has a handle  $B''$ , by which the workman puts the instrument in action; Fig. 2 shows the profile of the angles and hinges; and Fig. 3 shows more plainly, the support on which it turns, and the turning point by which it carries the stuff and frame in its movements.

To obtain more precision and solidity, the sides of the pantograph are joined together, so that the middle of their thickness is exactly in the vertical plane of the stuff, and the axles of the hinges as perpendicular as possible, to that plane in which, consequently, all

the movements are accomplished. This is effected by fixing on the large upper bar  $D''$  a bent piece  $d''$  (Figs. 1 and 3) having a proper jutting, and on which is also fixed the piece  $d'$ , which is joined to the extremity  $b d$  by a hinge; this piece  $d'$  is fastened to  $d''$  by an iron pin; but it has an oblong hole, and before fastening the nut it must be drawn backwards or forwards, until the support be exactly in the plane of the stuff. This condition being accomplished, it remains only to fix the frame to the angle  $f$  of the parallelogram; which is done by means of the piece  $F''$  (Figs. 1 and 3.)

It is now plain, that, if the workman takes hold with his hand of the handle  $B''$  (Fig. 1) and makes the pantograph move in any way, the point  $f$  will describe a figure similar to the figure described by the point  $c$  and 6 times smaller, as we have demonstrated, but the point  $f$  cannot move without moving the frame and all its supports; besides, if the frame is well fixed on all sides, and forced to move in the same plane, each of its points and of those fastened to it, will go exactly through the same way as the point  $f$ . Thus, in the motion of the pantograph, every point of the stuff describes a figure equal to that, described by the point  $f$ ; and consequently similar to that, which the point  $c$  describes and 6 times smaller. It is sufficient, then, to give to the workman, who holds the handle  $B''$  a drawing six times larger than that which must be executed by the machine, and to give him at the same time a sure and easy means to go with the point  $c$  through all the outlines of that drawing: for this purpose, there is fixed at  $c$ , and perpendicular to the parallelogram, a little style, terminated by a point  $C''$ , and the drawing is set on a vertical board  $E$ , parallel to the plane of the stuff and the parallelogram, and put back only a distance equal to the length of the style  $c C''$  (Figs. 1 and 2;) this board is supported by the iron rod  $e'$ , fixed on an iron foot  $E'$  (Fig. 1) which is also used for different purposes, as we shall show hereafter; the frame, loaded with its beams and stuff, forms a pretty heavy weight, and it will be observed that if it is necessary, as we have said to direct it, to keep it in its plane, it is necessary also to lighten it, so that the embroiderer may carry the point of the pantograph without effort or uncertainty in his movements.

Mr. Heilmann has accomplished this in the following manner:

1st. A rope  $e$  (Fig. 1,) tied to the side  $b c$  of the pantograph, passes over a pulley and supports at its extremity a weight which the workman may graduate, at will: this weight balances the pantograph and tends to raise the frame a little;

2d. The upper side  $F'$  of the frame carries two jutting rulers,

the profile of which is seen at E'' (Fig. 3,) both have a longitudinal and horizontal slit in which the rod e'' may easily slide (Figs. 1 and 3), which thus is used as a guide to maintain in its plane, all the upper part of the frame, for the rods e'' are fixed to the great bar D''; the length of the slit at each of the rulers E'' must be equal to the amplitude of the lateral movement, which the frame can take;

3d. The under side of the frame, has two horizontal rods H and H (Fig. 1) supported by two small arms, which are a little bent, as shown at h (Fig. 2;) each of these rods is fixed in the groove of a pulley H' (Fig. 1,) the blocks of which are of an oval form (Fig. 4) and supported by two triangular flanges h', h' on the two arms h'' which form the extremity of a forked lever H'', the profile of which is shown in Fig. 2; the two levers H'' must move together, in order that the two sides of the frame may be equally raised; therefore they are keyed on a shaft I', supported at its two extremities by feet of cast iron I' (Fig. 2,) a counterpoise I, which slides on the arms of the levers H'', and which, as it may be carried from or near the line of the supports, allows to raise the frame upwards to any required height, and without preventing the frame to move in all directions, prevents, however, its being displaced from the original plane, for which the pantograph had been regulated; the length of the rods H must also be equal to the amplitude of the lateral movement of the frame, and the arms of the levers H'' must be sufficiently long to let the arc, which they make the flanges h' (Fig. 4) of the pulley describe, be confounded by degrees with a straight line, in the greatest excursion from top to bottom or from bottom to top, which the frame can make.

4th. Two guides i, i (Fig. 1) supported on iron feet, have vertical slits in which the under side of the frame F' is fastened.

#### ARRANGEMENT OF THE CARRIAGES.

Before we describe the arrangement and action of the pincers which carry the needles, we shall explain the disposition and movement of the two carriages which carry these pincers and all their mechanism.

These carriages, which are entirely similar, are disposed one at the right and the other at the left of the frame (Fig. 2;) we shall designate by the same letters of reference the pieces which compose them.

Each carriage executes its movements on a railway, composed of

two rails as straight as possible and horizontally fixed, one at each side of the machine.\* One of these rails is seen at K (Fig. 2;) an end view is given on the right at No. 2, and its plan is represented in Fig. 5; the two jutting parts *k*, *k* are placed and bolted on two brackets, also bolted to the two vertical posts A C and A B of the frame: one of these brackets is seen at the left (Fig. 1,) the corresponding bracket of the other rail is seen also on the right, against the post A' B'. The carriage itself is composed only of a long hollow cylinder of cast iron L (Figs. 1, 2 and 6) having at each of its extremities two wheels L' which roll on the rails K (Figs 1 and 2;) the wheels L' are mounted on a piece l' (Fig. 2) forked to receive the axis of the wheels, and the piece l' is also bolted on the piece or appendix l (Figs. 1 and 6) which is cast on the cylinder L.

These pieces, which, properly speaking, constitute the carriage, are then in perfect equilibrium on the rails K, and thus may with the greatest facility approach or withdraw from the stuff to prick or draw the needles.

But, to supersede the necessity of employing a person to produce these alternate motions of the carriage, Mr. Heilmann attaches to it, a piece of mechanism by means of which the workman who directs the pantograph, can himself without changing his place, conduct the carriages and regulate, as he pleases, the extent of their course as well as the rapidity of their motions.

This mechanism, will perhaps appear to many readers, at first sight, a little complicated, but in reality it is *simple* and *very ingenious*, and what is an essential point, it acts with remarkable precision. We shall now endeavour to make this part of the arrangement understood.

A pulley J (Fig. 2) is fastened against the post A B at the right of the frame, by two stands J' and J'': a similar pulley is fastened to the other end of the frame against the corresponding post A' B' (Fig. 1 :) in this figure, the last only has been represented, and that which is fastened to the post A B has been suppressed, to show the wheel *m* (see left side of Fig. 1, and edge view in centre of Fig. 2) on which it would project. On a level with the centre of the pulleys J is fixed an iron shaft M'' (Fig 1) supported in proper couplings or bearings, which are fixed against the large posts A C and A' C'

---

\* The reader will, of course, understand, that there are two sets of rails K K, with their pulleys L' L', one set on each side of the machine, as seen at K K and L' L' (Fig. 1.)

(Fig. 1.) of the frame; the shaft  $M''$  has towards its extremities, but inside the frame, two cog wheels  $m$ : the left hand one is visible in Fig. 1, the right being hid by the pulley  $J$ ; its left extremity (pantograph side) projects outside the frame, to support another cog wheel  $M$  (Figs. 1 and 2.) On the pulley  $J$  and on the corresponding cog wheel  $m$ , passes an endless chain  $j$  (Fig. 2:) the part of this chain which must pass round the circumference of the wheel  $m$  is called Vaucanson's chain (*chaine-de-Vaucanson*;) the other which must pass round the circumference of the pulley  $J$  is a simple strap; the two extremities of the chain  $j$ , are secured, one at  $j'$  and the other at  $j''$  (Fig. 2) to the piece  $m''$ , which is supported by the extremity of the stud-pin  $m'$  (see right side of Fig. 1) which is fixed in the piece  $l$  of the extremity of the cylinder  $L$ ; this same stud-pin also carries a roller which runs under the rail  $K$ , to steady the carriage.

It results from this arrangement, that by turning the shaft  $M''$  (Fig. 1) or the wheel  $M$  (Fig. 2) in the direction indicated by the arrow (Fig. 2,) the carriage will be forced towards the stuff; and, on the contrary, by turning the wheel  $M$  in a direction opposite to the arrow, the carriage will move from the stuff.

The left hand carriage (Fig. 2) is arranged exactly as the right hand one, which we have just described; every thing is the same and designated by the same letters of reference, with the exception of the wheel  $M$ , which is at the extremity of the shaft  $M''$  corresponding to the second carriage, it is designated by the letter  $M'$ , because it is necessary to distinguish the two wheels  $M$  and  $M'$ , which are, however, in all respects similar and fixed in the same manner.

When one of the carriages has advanced and pricked the needles into the stuff, the other is there ready to receive them, it takes hold of them, draws them, performs its course in removing, to draw the thread and tighten the stitch, afterwards; it comes back and brings the needles to prick the stuff in its turn; during its motion, the first carriage must remain in its place waiting for it; thus the two carriages go alternately backwards and forwards, but never move at the same time.

To effect this, Mr. Heilmann has disposed on the piece  $O$ , which is bolted on the two posts  $A C$  and  $A D$  of the frame, a bent lever  $n o n' n''$ , moveable round the point  $o$ ; the bending  $n'$  has a cog-wheel  $O'$ , and the extremity  $n''$  another cog-wheel  $O''$ ; the four wheels  $M$ ,  $M'$ ,  $O'$  and  $O''$  have similar teeth and diameter; the two wheels  $O'$  and  $O''$  are fixed in relation to each other, so that it is sufficient to turn the handle  $N$  (Figs. 1 and 2) to make the wheel

$O''$  turn, and consequently the wheel  $O'$ : when the lever  $no$  is vertical, the wheel  $O'$  touches neither the wheel  $M$  nor the wheel  $M'$ , but when inclined to one side or the other, it will mesh or gear alternately into the wheel  $M$  or the wheel  $M'$ .

Viewing these parts as they are represented by Fig. 2, it is evident, that by turning the handle  $N$  in the direction indicated by the arrow, the wheel  $M$  will turn in the direction indicated by its arrow, and the right carriage will approach to the limit which prevents the pincers from touching the stuff, with a rapidity which depends entirely on the person who turns the handle  $N$ : by turning the handle in a contrary direction, the carriage will go backwards, and the simple movement of the lever  $no$  (Figs. 1 and 2) will suffice to act alternately on the left or on the right hand carriage. The reader will perceive, that when the lever  $no$  is vertical, the wheel  $O'$  will neither touch the wheel  $M$  nor yet the wheel  $M'$ , but if the lever  $no$  is inclined to one side or the other, the wheel  $O'$  will be geared into the wheel  $M$  or  $M'$ , alternately.

The workman having one of his hands occupied with the handle  $B''$  of the pantograph, and the other with the handle  $N$ , he has only his feet left to act on the lever  $no$ , and as he has yet many other things to do, Mr. Heilmann has placed before him two treadles, by means of which he executes with his feet a series of operations not less delicate than those he executes with his hands.

For the present, we shall consider these treadles only as the means of communicating motion to the lever  $no$ .

The treadles  $P$  (Figs. 1 and 2) are moveable round the axis  $p$  (Fig. 1), and have ropes  $p'$  rolled in a contrary direction on the pulleys  $P'$ ; these pulleys are fixed on a shaft  $P''$  (Figs. 1 and 2) supported on one side by the stand  $E'$ , and on the other by a piece  $K'$  fastened to the two large posts of the frame  $A C$  and  $A D$  (Fig. 2); the shaft  $P''$  supports at its extremity a piece  $r$ , represented in front, and a side view No. 3, a little above, and at the left of the place which it occupies (Fig. 1); it has teeth on a portion of its circumference (we shall see further the use of these teeth, but for the present we have only to speak of the part without teeth); and is furnished with a pin, which goes into the forked extremity of the lever  $no$ ; now, it is evident, that by lowering the treadle  $P$ , which is now raised (Fig. 1) the upper part of the shaft  $P''$  (supposed to be seen from the end as in Fig. 2) will turn from left to right, and the lever  $no$  will be inclined so as to gear the wheel  $O'$  into the wheel  $M'$ , but at the same time, the treadle which is now down will be raised, because its rope  $P'$  (Figs. 1 and 2) will of necessity be rolled



on its pulley in proportion as the other rope will unroll, so that the apparatus will be quite ready to act in a contrary direction, when needed.

#### ARRANGEMENT OF THE PINCERS.

The shaft *L'* (Figs. 1 and 2) supports from distance to distance, at spaces of about half a metre, appendices *q q* fastened to it (see also Fig. 6, where the scale is larger); it is to these appendices that are fastened, with two bolts, the curved arms *Q* (Figs. 1 and 2) which are destined to support all the mechanism of the pincers; Fig. 6 represents a part only of one of these arms but as they are disposed nearly in the same manner above and below (see Fig. 2) the shaft *L'*, this part is sufficient, with the Figs. 1 and 2, to give a complete idea of them: an iron rail, forming a well set triangular prism, represented at *S* (Figs. 6 and 7), extends between the two consecutive arms *Q, Q*, as seen in Fig. 1, and it is fixed against each of these arms by means of an ear *s'* (Figs. 6 and 7) in which passes an iron pin which crosses the thickness of the arm but instead of a simple hole, the ear has a slit which allows to carry it backwards or forwards. The workman can then put, one after another, in a very straight line, the three rulers *S*, which must be found in the three intervals of the arms *Q* (Fig. 1); each of them is a little prolonged beyond its two ears, so that, after they are properly arranged, the three consecutive rulers, seem to form but a single triangular prism, extending from one end to the other of the carriage. This prism is destined to receive and to support all the pincers that are found in a row.

Figs. 8, 9, 10 and 11, represent the different parts which compose one of the pincers. At *T* (Fig. 8) is seen the under jaw, set in its place and fixed on the prismatic ruler; it will be observed easily that it has:

1st. Underneath, a little to the left, a set screw *t*, by means of which it is fixed on this prismatic ruler, the form of which ruler it has at its under part;

2d. At the left extremity (see Figs. 6 and 8), a spring *t'*, used to raise the end of the upper jaw *V*, in forcing it to shut and to press against the under jaw;

3d. Upwards, and towards its middle, two little round ears, with a hole in them, and separated from each other by an interval equal to the thickness of the upper jaw, and destined to receive the corresponding ear *v* of this jaw;

4th. A little to the right of the ears, a small vertical jutting  $t''$ , serving to stop the needle, if by any cause it should be misplaced or too much in advance;

5th. At the right extremity, a thin plate  $T'$ , having a conical hole larger inside than outside; a front view of this plate is represented at Fig. 11.

The upper jaw  $V$  has been removed from its place in Fig. 8, in order to show its form better.

It will now be perceived, that if the upper jaw  $V$  of the pincer (see Fig. 8) is dropped down into its place between the ears  $t''$  and a pin passed through these ears, the pincer will be complete, or like that shown in Figs. 2, 6 and 7.

In order that the pincer may be opened to receive the needle, the long end of the upper jaw  $V$  must be pressed down sufficiently to overcome the elasticity of the spring  $t'$ .

Fig. 9 represents a view of the pincer from above (a plan view); it also shows the size of the jaws and that of the spring  $t'$ .

Fig. 10 represents a pincer, seen from the end, on the side of the plate  $T'$ .

Fig. 12 represents a needle  $V'$ , of full working size; the eye is in the middle, the thread is put in it as in a common needle, but it is not doubled, the filaments of the short end are only mixed with those of the long near the needle, and are slightly twisted, so that they may hold better, and go more easily through the stuff through the hole which the needle makes.

When a pincer is opened and half of the needle comes to be engaged in it, by the opening of the plate  $T'$ , it is fixed in an angular groove, the depth of which is a little less than the diameter of the needle; and when the pincer is shut, the upper jaw  $V$ , holds it in the groove; thus the needle is held fast, by three points of its circumference.

Suppose now, that all the pincers are set at a proper distance on the prismatic ruler  $S$  (Figs 6, 7 and 8) to form the upper row of the right hand carriage, as seen in Fig. 1, we shall endeavour to explain by what kind of mechanism the workman succeeds in opening, at the same time, all the pincers of the upper row, when they should deliver up the needles to those of the opposite carriage, after having pricked them into the stuff.

There is for this purpose, an iron shaft  $U$  which extends from one side of the carriage to the other (see Fig. 1); an end view of this shaft is shown at  $U$  Fig. 13, by which it will be seen, that it is flat on one side: this shaft is supported by little forks  $u$  (Fig. 6) which

are fastened with bolts at the extremity of the arms Q, and it is fixed there by a key-pin  $u'$ ; the shaft is round in the parts which rest in the forks, and these are of such a height, that when its flat part is turned downwards, it touches the ends of all the upper jaws Y, without pressing them, so that the pincers remain shut, and it opens them when it turns on its axis, by forcing down the springs  $l'$ .

To produce this effect, Mr. Heilmann fixes at the two extremities of the shaft U two sectors with teeth  $x, x$ , a side view of which may be seen in Fig. 2; each of these sectors gears into a toothed vertical ruler X (Figs. 1 and 2) which can slide against the arm Q of the carriage, where it is fixed, and the ruler X has at its under part an horizontal pin  $x'$  (Figs. 1 and 2); it is by means of these pins that the movement is communicated to the ruler X, and to the sector  $x$ , and consequently to the shaft U, to open and shut the pincers.

We shall now try to explain how the workman performs this operation, by means of the two treadles P (Figs. 1 and 2.)

We have already said, that the shaft P'', which is put in motion by the treadles P, supports at its right extremity (Fig. 1) a piece  $p'$  destined to make the lever  $no$  act; this piece is represented in front at Fig. 2, and on the left at No. 3; it has teeth on two-thirds of its circumference, and is used as a pinion; with its toothed part, it gears into a sector  $r$ , fixed at the extremity of the shaft R (Figs. 1 and No. 3) which can revolve on its axis and is supported by proper bearings  $r' r'$  (Fig. 1), placed in the middle of the horizontal and lower bars of the frame. The shaft R also supports two arms Z Z (Fig. 1 and No. 3), placed crosswise upon it, and terminated by forks  $z$  and  $z'$ ; the two forks designated by  $z'$  correspond to the left hand carriage (as seen in Fig. 2), and those designated by  $z$  correspond to the right carriage; they are destined to receive the stud-pins  $x'$  of the notched rulers X; and it is very easy to understand how they operate. For, taking these parts as they are represented in Fig. 2, let us suppose that the workman brings the right carriage towards him, by turning the handle N, in the direction of the arrow: then, the carriage advancing, secures the stud-pins  $x'$  in the forks  $z'$ , and pricks into the stuff the jutting half of the needles which it carries, and these halves enter into the pincers of the left hand carriage, which are open to receive them, it is then necessary instantly, to shut the left hand carriage pincers, so that they may take the needles and open the right hand carriage pincers to give them up. This the workman does with his foot, at once; he bears on the raised treadle to draw the rope which it sup-

ports; then the movement of rotation which is produced in the corresponding pulley is communicated to the shaft  $P''$ , pinion  $p''$  sector  $r$ , shaft  $R$ , and simultaneously to the two arms  $Z, Z$ , the extremities  $z, z$  of these arms (Figs. 1 and 2) are raised and carry the stud-pins  $x'$  in their ascending movement, consequently the toothed rulers  $X$  ascend in sliding in their grooves or guides, make the sectors  $x$  and the flat sided shaft  $U$  turn, which gives pressure on the end of all the upper jaws  $V$  of the pincers and opens them all at once, by means of the arms  $Z, Z$  (No. 3), the forks  $z, z'$  which terminate them at the left, descend and carry with them the stud-pins  $x'$  of the toothed rulers  $X$  of the left hand carriage, make the corresponding sectors  $x$  turn as well as the flattened shaft  $U$ , on which they are fixed; its flat side coming on the ends of the upper jaw  $V$  of the pincers, and all the pincers of this side are shut by means of the springs  $t'$ . Thus at the same time, the workman shuts the pincers of the left hand carriage and opens those of the right hand carriage, which will remain open until they have received the needles, after the return of the left hand carriage. The same movement of the treadle, which produced this double result, has also changed the position of the lever  $n o$  (Fig. 2) and brought the wheel  $O'$  on the wheel  $M'$ ; so that the workman has only to turn the handle  $N$  to give motion to the left hand carriage, which draws the needle and tightens the stitch.

The threads are stretched in proportion as the carriage withdraws, but this tension presenting no elasticity, some inconvenience might have happened, had not Mr. Heilmann fixed to the carriages a piece of mechanism by means of which every thread is pressed at the same time by a weight, which is easily regulated, as will be hereafter more fully explained.

The reader will see in Fig. 1 (a little below the prismatic rail which supports the pincers) a shaft  $Y$  which extends across the carriage and projects over it at each side; this shaft is supported by pieces  $y$  which are bolted on the arms  $Q$  (Figs. 1, 2 and 6) in which it may turn; at its left extremity, it has two little bars  $y'$  and  $w$ , and at its right extremity a single bar  $y'$  and a counterpoise  $y''$  which may be seen in Fig. 2; the extremities of the two bars  $y'$  are connected by a stout wire which extends across the machine (Fig. 1) and which wire must be very straight: this wire is simply twisted together at its ends after having taken a turn round the notched ends of the bars  $y'$ , as will be seen, on close examination (Fig. 1); the position of the wire, connected to the ends of the bars  $y'$  is also indicated in Figs. 2, 6 and 7; all the threads which come from the needles must

pass under this wire, (see Figs. 2 and 6.) When the carriage approaches the stuff, and before the wire touches it, the bar *w*, (the position of which is seen in Fig. 2) meets a stud-pin *w'* (Fig. 1), which bears against it and raises it gradually; the bars *y'*, *y'* and the wire which connects them is raised at the same time and take the position represented in Fig. 7: on the contrary, when the carriage, in leaving that position, goes from the stuff, the bar *w* slides in descending on the pin *w'*, is removed to a little distance, and then the counterpoise *y''* makes the bars *y'* fall, bringing down the wire which connects them, on all the threads of the needles; after which the machinery takes the position indicated in Figs. 2 and 6.

In the description just given, we have only considered the upper range of pincers and needles, in order to simplify our demonstrations, but it will be seen that in Figs. 1 and 2, there is an under range of pincers and needles which are also connected to the lower extremity of the arms Q, exactly similar to the upper range; the machinery which opens and shuts the pincers is also the same, and operates simultaneously, which will be seen by referring to Fig. 2, because the sectors *x x* and toothed rulers X X are the same: the flattened shaft U of the upper carriage is precisely the same as that of the under carriage. Tension is communicated to the threads of the lower needles by an arrangement the same as that above designated by the letters of reference Y, *y*, *y'*, *w* and *w'*, (see Figs. 1 and 2.)

Having thus described, to the best of our ability, this beautiful piece of mechanism, we will offer a few remarks in regard to its operation.

The size of the patterns which the machine can embroider is limited, as well as the number of needles to be set at work; because, all the needles in each carriage (on the same horizontal line) have each its respective pattern, so that the number of patterns to be embroidered will be equal to the number of needles employed. For example, in Fig. 1, there are 15 patterns in each range; these would require one needle each; it is therefore evident, that the distance between the needles, respectively, must be somewhat greater than the breadth of the pattern to be embroidered, or the motion of the frame would cause a part of the stuff which had been embroidered by one needle, to come in front of another needle.

Therefore, if it is desired to work with 130 needles, 65 above and 65 below, and if, for example, each pattern was to be 7 inches in breadth, it is very evident, that the distance between the needles should be rather more than 7 inches, and would require a machine

more than 65 times 7 inches, or about 13 metres in breadth : but, the arrangement of the mechanism will not allow to give the machine so great a breadth : hitherto the machines have been confined to  $2\frac{1}{2}$  metres for the working part, carrying on this space 130 needles, that is to say, 65 above and 65 below, set at a distance of about  $1\frac{1}{2}$  inches apart (*mettre á la distance d'environ 4 centimètres*) ; this then is the maximum of the breadth of the patterns to be embroidered.

To embroider patterns of a larger size the number of needles must be diminished so as to allow of a greater distance between them : it would be necessary, for instance, to reduce them one-half, to produce patterns 3 inches (*3 centimètres*) wide.

But, in diminishing the number of needles, we decrease the advantages of the machine ; because, it requires as much time to work a carriage with 50 needles as one with 130.

Although the machine is limited in its width, it has the advantage of having no limit in its length or height ; it may, for instance, embroider at the same time 130 ribbands of any length ; it will suffice to dispose these ribbands on the beams G, and to embroider all the height which the vertical motion of the frame allows ; then the workman marks the place where he has left off, and stops the working of the machine for a moment, while he rolls on one of the beams G the embroidered part which he had executed, and brings before the needles the new stuff which is to be embroidered ; he makes the point of the pantograph rise or descend, according to the part last finished, whether above or below, the pattern on the table E (*Fig. 1*) being raised or lowered to correspond ; and then continues to embroider from the mark which he had made before rolling the stuff on the beam.

It will be perceived, that the workman must not follow with the pantograph, the pattern which is on the board E, but must stop the point of that instrument on the point or little square of the design paper or pattern which the needle is going to prick, he carries it again and stops it on the point through which the needle should go or enter in returning, and so forth.

To facilitate this kind of reading, the pattern which is on the board E, is composed of straight lines, crossing each other at right angles, as in *Fig. 70*, (which see) so that the workman has continually under his eye the pattern divided off into small squares, which he must follow with the point of the pantograph ; should he happen to be interrupted and have neglected to mark the place where he left off, he must look at the embroidered stuff in the machine,

to see what has been already embroidered and to find by comparison with the pattern on the table E, where he is to commence his work again, in order to leave nothing undone and not to repeat twice the same thing.

## INDEX TO PLATES 1 AND 2.

- ABCD**, Fig. 2, The side of the frame where the workman sits.  
**A' B' C'**, Fig. 1, The opposite side of the frame.  
**A''**, Fig. 1, Lower cross-bars which connect the feet of the two sides of the frame.  
**a**, The six feet of the frame, (Fig. 2) on the pantograph side.  
**a'**, The six feet of the opposite side of the frame, (see Fig. 1).  
**a''**, Fig. 1, Knees which unite the cross-bars A'' to the vertical posts of the frame.  
**B''**, Figs. 1 and 2, Handle of the pantograph.  
**b, b', b''**, Three of the angles of the pantograph.  
**c**, Point of the side *b b''* on which the point is fixed.  
**C''**, Fig. 2, Point of the pantograph.  
**D''**, Figs. 1 and 2, Cross-bar in the shape of a trough which unites the frame above.  
**d**, Fixed points on which the pantograph turns.  
**E**, Fig. 1, Board on which the pattern to be embroidered is put.  
**E'**, Support of the board E.  
**e**, Rope attached by one end to the side *b c* of the pantograph, passing over a pulley, and having a weight at the other end.  
**e'**, Iron rod to support the board E.  
**E''**, Fig. 3, Sliding rule fixed on the side F' of the frame.  
**e''**, Figs. 1 and 2, Rod fixed on the cross-bar D'' and sliding in the sliding rule E''.
- FF**, Figs. 1, 2 and 3, Vertical posts of the frame which carries the stuff.  
**F' F'**, Figs. 1, 2 and 3, Horizontal sides of the same frame.  
**F''**, Figs. 1 and 3, Stand fixed on the upper side F' of the frame and connected by an axis pin to the pantograph.  
**f**, Fourth angle of the parallelogram which forms the pantograph.  
**G**, Figs. 1, 2 and 3, Four rollers or wooden beams fixed on the vertical posts of the frame for carrying the stuff.  
**G'**, Figs. 3 and 7, Two rulers fixed on the same posts and intended to maintain in the same vertical plane, the stuff rolled on the beams G.  
**g**, Fig. 3, Ratchet wheels fixed at one of the ends of the rollers G.  
**g'**, Catches which hold the wheels *g*.  
**G''** Stuff.  
**g''**, Fig. 1, Strings used to stretch the stuff sideways.  
**H**, Guide-rods fixed to the under side of the frame which carries the stuff.  
**h**, Figs. 1 and 2, Curved arms which support the rods H.  
**H'**, Figs. 1 and 3, Throated pulleys in which the rods H slide.  
**h' h'**, Figs. 1 and 4, Flanges by which the blocks of the pulleys H' are supported.  
**H''**, Large levers which support at one end the blocks of the pulleys H' and at the other counterpoises I (Fig. 2.)

- h'*, Fig. 1, The two extremities of the forks of the levers *H''*.
- I*, Counterpoise of the lever *H''*.
- I'*, Fig. 2, Shaft on which are supported the levers *H''*, fixed to answer for each other and so that the two sides of the frame which carries the stuff be supported and moved at the top with an equal force.
- I''*, Figs. 1 and 2, The two supports of the extremities of the shaft *I*.
- i*, Fig. 1, Two iron feet having a vertical slit in which slides the under edge of the frame, serving to maintain it in its plane during its motions.
- J*, Fig. 2, Pulleys at each end of the frame.
- J'* and *J''*, Figs 1 and 2, Stands which support the pulley *J*.
- j*, Endless chain.
- j'* and *j''*, Points to which the extremities of the endless chain are attached.
- K*, Figs. 1, 2 and 5, Rails for the carriages; Fig. 5 represents one of these rails, seen from above, with flanges *k* by which it is bolted to the upright posts *B* of the frame.
- K'*, Fig. 2, Cross pieces bolted to the two posts *A D* and *A C* and supporting the extremity of the shaft *P''*.
- k*, Flange of the rails *K*.
- L*, Figs. 1, 2 and 6, Shaft or cylinder of the carriage, having at its two extremities a flange by which it is fastened to the wheel-carriers *l'* and having besides from distance to distance appendices *q*, *q* destined to receive the large arms *Q Q*.
- l*, Flanges, through which the axis of the shaft *L* is fixed to the wheel-carriers *l'*.
- L'*, Small wheels which support the carriage on the rails *K*.
- l'*, Wheel-carriers, forked at the two extremities to receive the axles of the small wheels *L'*.
- M, M*, Figs. 1 and 2, Cog-wheels, set on the front extremity of the axles *M''* and outside of the frame.
- m'*, Fig. 1, Cog-wheel, set on the shaft *M''* inside the frame.
- M'' M''* Two shafts turning in bearings fixed on the large posts *A D*, *A D'* and *A C*, *A C'* of the frame; one of these shafts is shown in Fig. 1.
- m'* Stud-pin crossing the piece *l'*, and supporting the wheel *L'* which rolls on the rail *K*.
- m''* Fig. 2, Piece supported also by the stud-pin, *m'* and to which the endless chain is connected, (Fig. 2).
- N*, Figs. 1 and 2, Handle by means of which the wheel *O''* Fig. 2, is turned, to move the carriages forward or backward.
- n, n', n''*, Bent lever supporting the two cog-wheels (*O'* and *O''*) and supported by the axis pin *o*, Fig. 2.
- O*, Cross-bar (Fig. 2) connecting the sides *A C* and *A D* of the frame.
- o*, Support or axis of the lever *n, n', n''*.
- O'* and *O''*, Two cog-wheels gearing into each other, fixed to the points *n'* and *n''* of the bent lever *n, n', n''* and moving with it (Fig. 2.)
- P*, Figs. 1 and 2, Two treadles.
- p*, Axis of the treadles *P*.
- P'* Pulleys fixed on the shaft *P''* and moving with it.
- p'* Ropes which connect the treadles *P* to the pulleys *P'*.
- P''* Shaft which carries the pulleys *P'*.
- p''* Piece fixed at the extremity of the shaft *P''*; it has teeth on  $\frac{3}{4}$  of its circumference, and the other part is prolonged and



- has a stud-pin which goes through the forked extremity of the lever *no* to make it move, Figs. 1 and 2.
- Q, Q**, Figs. 1, 2 and 6, Large arms of cast iron, which are fixed on the shaft or cylinder **L**, by means of the flange *q, q*.
- q, q**, Flange intended to support the arms **Q Q**.
- R**, Fig. 1, Shaft supported at the under part of the frame by two bearings *r' r'*.
- r** Sector with teeth, supported on the extremity of the shaft **R**, and gearing into the pinion *p''*.
- r' r'**, Bearings fixed on the frame and supporting the shaft **R**.
- S**, Figs. 1, 2 and 6, Prismatic rule supporting the pincers; it is fastened between two consecutive arms **Q Q** by means of the ears *s' s'*.
- s' s'** Ears to which the arms **Q Q** are bolted.
- T**, Figs. 6, 8, 9 and 10, Under jaw of the pincer.
- t**, Screw intended to fasten it on the prismatic rail.
- T'**, Plate pierced by a hole through which the needle goes into the pincer, (Fig. 11).
- t'** Spring intended to press down the upper jaw of the pincer on the needle.
- U**, Fig. 1, Flat shaft supported by the extremity of the arms **Q Q**; it is also shown in Figs. 6, 7 and 13.
- u**, Fig. 6, A small fork piece which supports the axis of the shaft **U**.
- u'**, Key pins which keep the axis of the shaft **U** in its place in the fork pieces *u*.
- V**, Upper jaw.
- v**, Ear used to connect, by means of a pin, the upper jaw of the pincer with the under one, (Fig. 8).
- V'**, Fig. 12, Needle of the full size, with the eye in the middle.
- w**, Arm at the extremity of the shaft **Y**, and intended to make the shaft turn at the moment when it leaves it.
- w'**, Stud-pin fixed to the frame, and against which the small arm *w* slides, (Fig. 1).
- w''**, Two small arms fixed, one on the upper shaft **Y**, the other on the under shaft **Y'**; they are connected by a wire, so that the motion of the shaft **Y** produces that of the shaft **Y'**, (see middle of Fig. 1.)
- X, X**, Figs. 1 and 2, Two vertical rules with teeth sliding against the arms **Q Q**.
- x**, Sectors gearing with the teeth of the rules **X** and fixed on the flat shaft **U** with which they turn, (Fig. 2.)
- x'**, Stud-pins fixed at the bottom of the rules **X**, Figs. 1 and 2.
- Y, Y'**, Figs. 1 and 2, Shafts supported by the arms **Q** and turning freely.
- y, y'**, Small perpendicular arms or rods on the ends of shaft **Y**, Figs. 1 and 2.
- y''**, Counterpoise of the arm or rod **Y**, Figs. 1 and 2.
- Z Z**, Arms fixed on the shaft **R**; each being terminated by two forks *z z*, Fig. 2, one at the right, and the other at the left.
- z, z'**, Forks which terminate the arms **Z Z**, and which are intended to receive the stud-pins *x'* of the toothed rules **X X**.
- No. 1, Horizontal section of the post **AB**, seen from above, and also showing the thickness of and the shape of the foot *a*.
- No. 2, Section of the rail **K**.
- No. 3, A view in profile and in front of the pinion *p''*.

PLATE

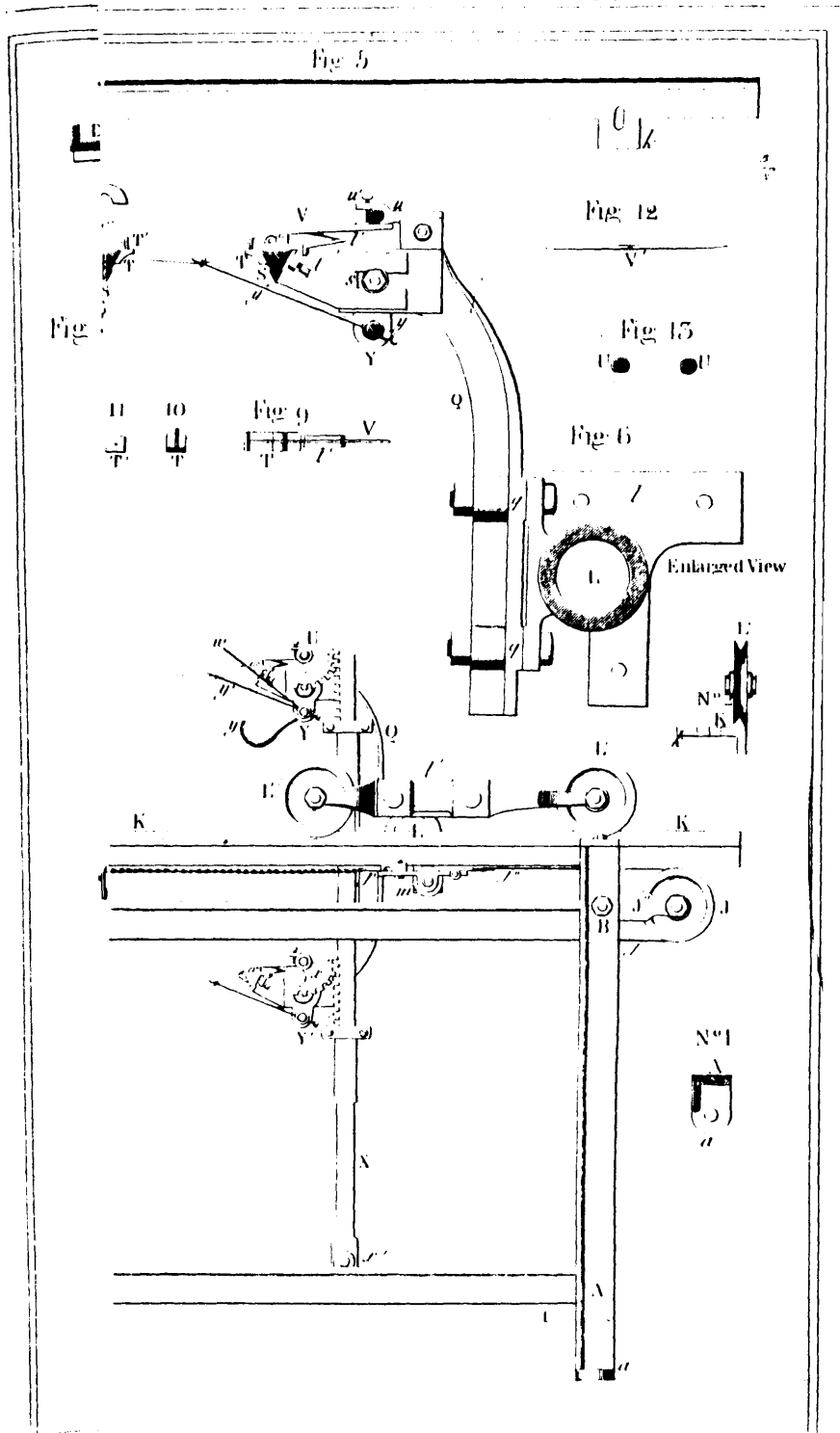

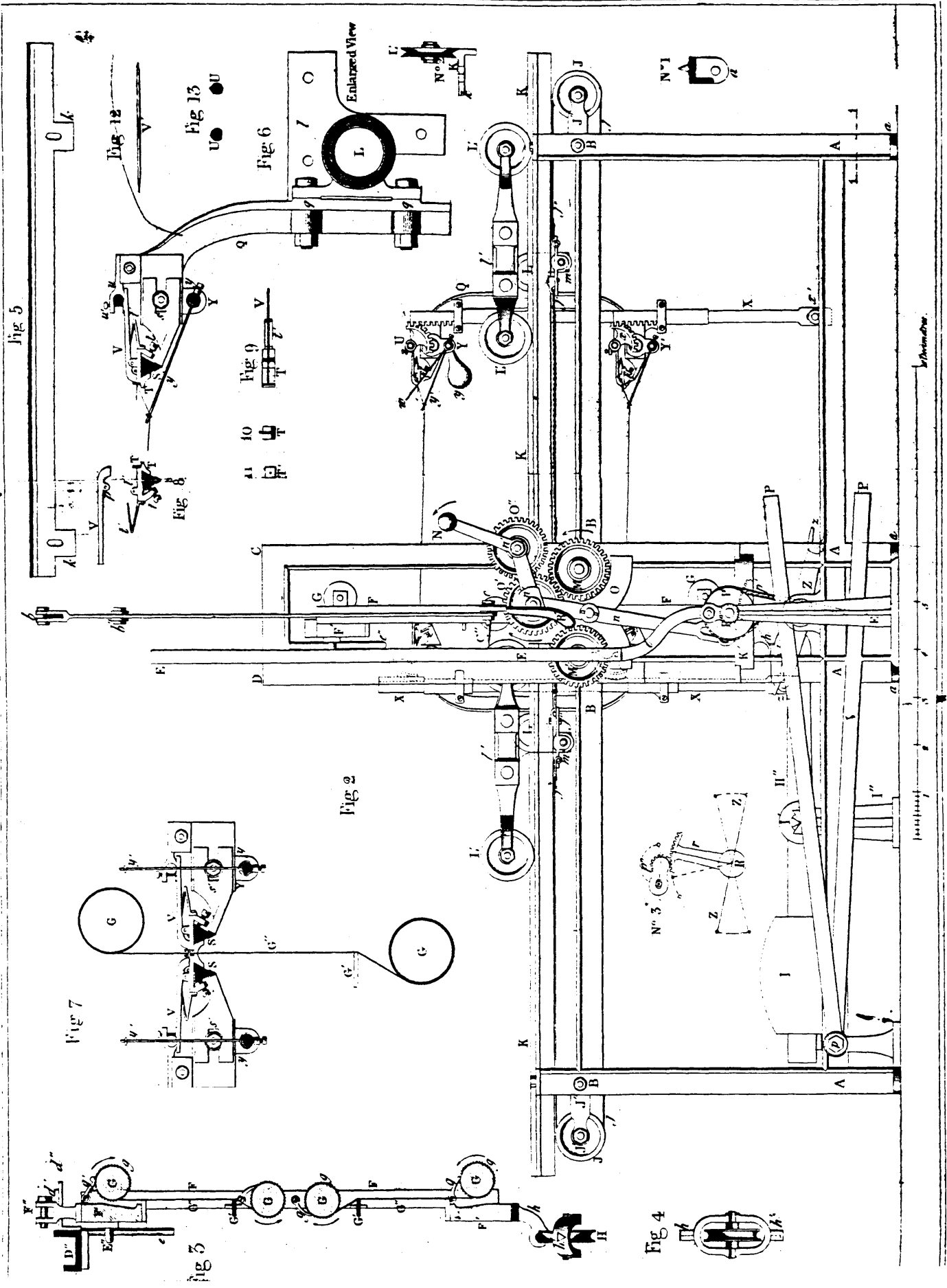

Fig 5

Fig 12

Fig 13

Fig 6

Fig 2

Fig 7

Fig 9

Fig 10

Fig 11

Fig 4

Enlarged View

Inventor

In concluding this part of our subject we cannot but express our admiration of those talents which have overcome difficulties in the construction of machinery, as great as any ever conquered by human skill and perseverance. The embroidering machine is not the only invention which Mr. Heilmann has given to the world; for we find, by referring to the records of the "Société Industrielle de Mulhausen," accounts of several other inventions of his in different branches of manufactures, particularly in power loom weaving; and among many interesting papers furnished by this gentleman and published in the "Bulletin" of the "Société," there is a memoir entitled "Observations Microscopiques sur la forme, la finesse, et la force des filamens de Coton," containing much valuable information.\* Indeed, we may say of Mr. Heilmann what Lord Jeffrey

---

\* We extract the following characteristic *morceau* from page 543 of a book entitled, "Baines's History of the Cotton Manufacture," as a specimen of the envious spirit entertained by Englishmen (especially of the middle class) towards the French:—

"NOTE

Relative to the Form of the Fibres of Cotton. By JAMES THOMSON, F.R.S.

In the first volume of the '*Bulletin de la Société Industrielle de Mulhausen*,' published in 1828, is a memoir, by Mr. Josue Heilmann, entitled 'Observations Microscopiques sur la forme, la finesse, et la force des filamens de Coton,' in which he ascribes to the fibres of Cotton the same form precisely given to them in the drawing of Mr. Bauer, dated Feb. 11, 1822, which accompanies my paper 'On Mummy Cloth.'

Mr. Heilmann's 'Observations' are accompanied by a drawing of Mr. Edward Koechlin, of the fibres of cotton. Whoever will take the trouble to compare the two drawings, will detect internal evidence of the one being derived from the other. Mr. Heilmann's paper being published in 1828, and mine in 1834, renders some explanation necessary.

In 1822 or 1823, Mr. Edward Koechlin was in England, and during a visit he paid to me at Primrose, he saw Mr. Bauer's drawing, and requested permission to copy it, which was readily granted. It is from this drawing and Mr. Koechlin's communication, that Mr. Heilmann's 'Observations Microscopiques' are derived.

The paltry fraud of appropriating to himself the observations of others, without acknowledgment, might have passed unnoticed by me for ever, had not the friends of Mr. Bauer considered this explanation necessary."

We have the pleasure of being well acquainted with Mr. Heilmann, and know that he is not only an extremely ingenious man, but also a man of sterling honour and strict integrity, and altogether incapable of any thing of this sort. We will venture to assert, that Mr. H. possesses more real inventive talent than Mr. Bauer and all his friends put together. Why do not these gentlemen also lay claim to the embroidering machine which we have just described? Perhaps they invented it too!

said of James Watt:—"Independently of his great attainments in mechanics, he is an extraordinary, and, in many respects a wonderful man;—possessing infinite quickness of apprehension, a prodigious memory, and a certain rectifying and methodizing power of digesting and arranging in its proper place, that which is really valuable in practice, and of casting aside and rejecting, as it were instinctively, whatever is worthless or immaterial."

---

## SECTION NINTH.

### SPOOLING, WARPING AND SIZING BY POWER.

THE processes of spooling, warping and sizing having been already thoroughly investigated, as applicable to looms worked by hand (see Section First,) it only remains to show how these various processes may be facilitated, by the application of power instead of manual labour: this subject we shall now endeavour to elucidate.

Were we ambitious of confusing the wits of the rabble with *very learned* dissertations on spooling, warping and sizing, we would call in the aid of that mysterious art, known to patent agents and quack doctors by the cognomen of "*saw-dusting*;"\* but our object is to diffuse *light* and not *darkness*.

Fig. 148 represents a common cylindrical shaft, containing 16 drums A, with four spools B B B B, which roll against the drum, by friction of contact; C C represent cast iron arches fixed between each pair of drums, and serving to keep the spools in their places

---

\* A villainous system of trickery or deception, by which a lie is garnished over and made to appear as truth: it is commonly practised by men of no real inventive talent or capacity; but whose impudence is their grand substitute for genius. Such characters often apply to some dishonest patent-agent, or petty lawyer, whose business it is to assist them in their difficulties; which he does by drawing out a long windy rignarole specification of some 5,000 odd words, purposely to work up the invention or inventions of some ingenious man, under pretence of making improvements thereon; and then gilding the pill over so skillfully in the summing up of the claim, as to be swallowed by the public without a shrug!

(see DD, Fig. 149.) Each spool has suitable iron gudgeons at its ends, serving as an axis on which it revolves (see Fig. 148.) E E are the bobbins from the spinning frame: F F are cylindrical pieces of iron covered with cloth, lying on the moveable rails G G. Pieces

Fig. 148.

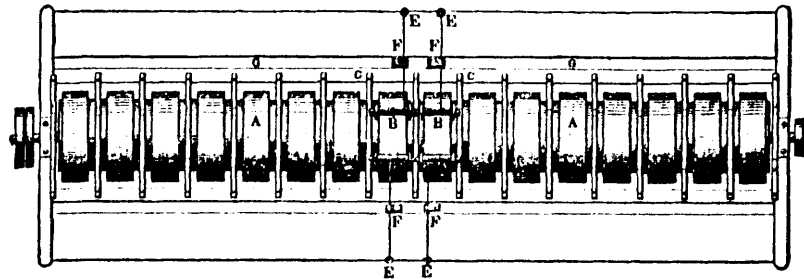

of cloth are also fastened on the rails beneath the cleaners F F, so that the thread passes through between the two plies of cloth, which partly smooth down the fibres, and clean it from any loose specks that may adhere to it; II are guide pins fastened on the rails G G (Fig. 149.) The pulley J, driven by a band from the cylinder shaft, is connected with a heart motion, which moves the rails G G alternately in a horizontal direction the full length of the spools, and by means of the guide-pins II, causes the yarn to wind on equally from end to end of the spools. Each of the drums A is covered with cloth or leather, and requires to be perfectly true, as otherwise it would give a vibratory motion to the spools while the yarn is winding on.

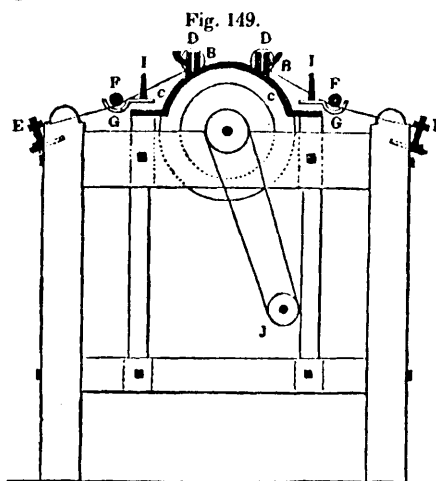

This machine is extremely light, simple in its construction, and easily kept in order. A machine containing twenty drums may be attended by two girls of twelve years of age, and is capable of winding 3,000 hanks per day of  $12\frac{1}{4}$  hours.

Instead of winding the yarn off the small bobbins on to others of a larger size, it is common in a number of factories to take the bobbins direct from the spinning frame to the warping machine, which is mounted with a rack or creel suited to the size of the bobbins. This creel, rack, or bobbin frame, is attached to the back of the warping machine, and lies in a horizontal position, but is hollowed in the centre like a cradle; hence it is denominated the cradle warper. The girl who attends this machine stands with her face towards the back of the warper, having the bobbin frame intervening; she thereby has all the bobbins within her reach, so that whenever she perceives one nearly empty, she is ready to remove it, replace it with a full one, and tie the two ends of the thread, without stopping the machine. And owing to the number of bobbins in the frame, and the small quantity of yarn contained on each, they are constantly emptying, while the attendant is constantly supplying their places with full ones; but in order to prevent them from running out entirely, she requires to take out a considerable number before the yarn is completely wound off. The yarn, therefore, which is left on the bobbins, if not wound off at some other machine, is liable to be made into waste. Hence the cradle warper has not been generally adopted, as it has been found that the loss from the quantity of waste made by it, is greater than the expense required for spooling, or winding the yarn from small bobbins on to others of a larger size, suited to the common bobbin frame of a warping machine.

The next step preparatory to the operation of weaving is the formation of the warp or chain, that is, the longitudinal threads of the web, which lie parallel to each other through the breadth of the cloth. The bobbins are transferred to the warping machine; and though this machine is very simple in its construction, yet it is well worthy our notice.

#### WARPING MACHINE.

The species of warping machine which we shall now endeavour to explain is an American invention, and is far superior to those used in Great Britain; for it has the advantage of being provided with an

ingenious contrivance by means of which it is instantly stopped on the breaking of a thread.

Fig. 150.

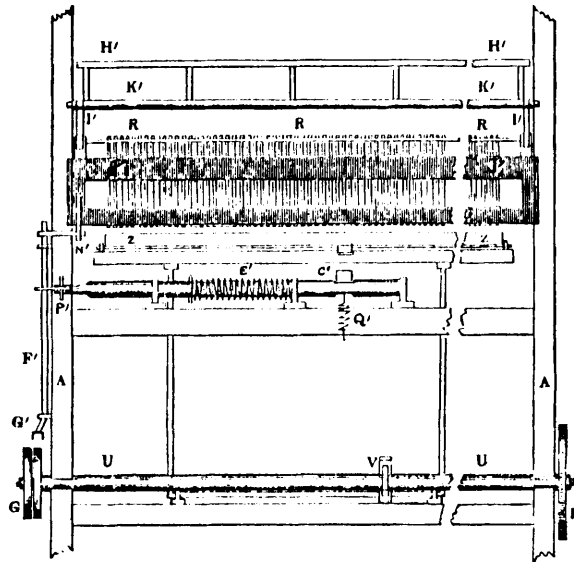

AA, Figs. 150 and 151, is the framing of the machine, which being constructed of wood, gives it a heavy appearance in the drawings; B Figs. 151 and 153 are the threads proceeding from the bobbin frame to the iron plate C, where each thread is separated; the plate C being perforated with small holes corresponding to the number of threads to be wound on the beam. Passing the plate C, where all the threads are brought into one horizontal plane, they thence pass over the rods DD: from these through the guide-reed E and on to the beam F, which is represented as containing only the first round of the yarn. The belt pulleys G are on the same shaft with the wheel H, which drives the wheel I; on the same axis with the wheel I, is the drum J, which drives the yarn beam F. The drum J, on which the yarn beam rests, and by which it is moved, is exactly one yard in circumference, and upon one end of its axis, there is a screw working into small geared wheels connected with an index, which indicates the revolutions of the drum during the warping of each beam, from which the length of yarn on each beam is ascertained, and the attendant is paid accordingly. The axis of the yarn beam rests on two slots of the framing at K, and is pressed down upon the drum J, by the stirrup L.L, which is also weighted down by the cross lever M. From the top of the



stirrup L, an arm N extends to the guide reed E, so that as the yarn fills on the beam F, it gradually rises, and the arm N presses up the guide reed with the same gradual motion, so as to keep it always in a proper position in relation to the increasing diameter of

Fig. 151.

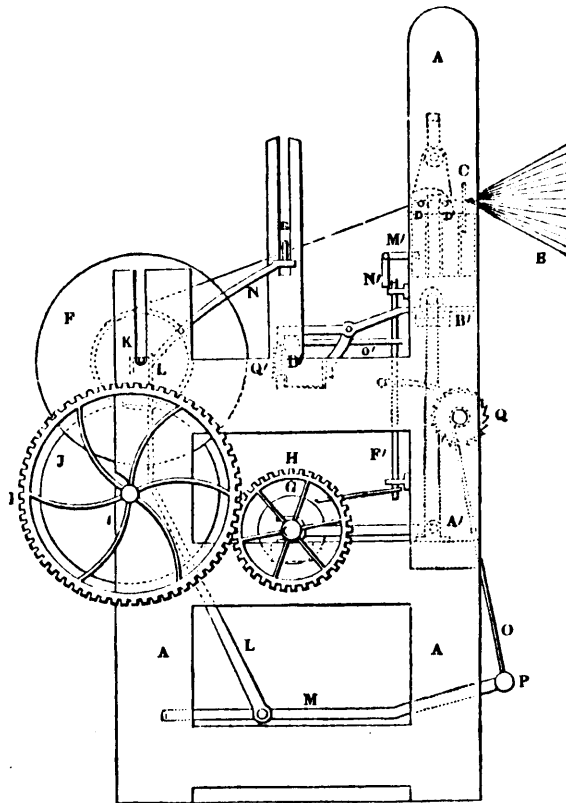

the yarn beam: O, Fig. 151, is a strap attached to the weight P, and which winds round a small shaft, on the end of which the ratchet wheel Q is made fast. When the beam is sufficiently full, the strap O is wound up by means of a wrench attached to the ratchet wheel, which thereby lifts the weight P, the lever M and stirrup L, until the hook on the axis of the yarn beam at K, is so far relieved as to be pressed back: the full beam is then removed, and an empty one put in its place—the stirrup is brought forward till the hook is above the axis of the beam—the catch of the ratchet wheel is lifted—the strap unwound—and the machine is then ready to warp another beam.

From the foregoing description, it will be seen that this warping machine differs very little from those used in Great Britain. It is however in every respect as simple and efficient, besides having the advantage of the stop-motion; and which will now be described.

As the yarn from the bobbin frame enters the plate C, it passes over the rods D D; but between these rods, there is a drop-wire suspended upon each thread: these drop-wires are pieces of flattened steel wire, about four inches long, from  $\frac{1}{8}$  to  $\frac{3}{16}$  broad, and  $\frac{1}{16}$  of an inch thick: their weight varies from 4 grains 4 dwts. to 4 grains 10 dwts. They are hooked at the top, and suspended by their own weight on each thread. (See R R R, front view, Fig. 150, and R, Fig. 153.) When the machine is in operation, the drop-wires are borne up by the tension of the threads, but as soon as any one thread breaks, it slackens, and, of course, the wire drops down till the point of the hook at S, Fig. 154, rests on the plate T T, Fig. 153; and it is this dropping down of the wire that stops the machine. The shaft U U extending across the machine, has an eccentric at V, Figs. 150 and 153, which works into the fork of the lever W W. On the top of the lever W W, there is a small tumbler X Y X attached to the steel plate Z, Figs. 150 and 153. The lever W W turns upon a journal at A', Figs. 151 and 153; and in consequence of the eccentric V working into the fork, the top of the lever, and with it the tumbler X Y X, and the plate Z are made to oscillate under the drop-wires; so when a thread breaks, the wire drops down, and retards the oscillating motion of the plate Z, which immediately depresses either end of the plate X X of the tumbler, which again presses down the lever B' C' at B', and raises the other extremity at C'. By lifting the lever at C', the rod D' D', being then disengaged, is operated upon by the spiral spring E', Fig. 150, which causes it to shift so far as to act upon the upright rod F', and turn it round as far as to make the belt lever G', shift the belt from the fast, on to the loose pulley. And as these various parts are fitted so as to operate all at once, the machine upon the breaking of one thread will be instantly stopped.

When the broken threads are all tied, and the machine ready to be put in motion, the girl attending, lays hold of the rail H' H', Fig. 150, and pulls it forward; P P are straps of leather fastened to the wooden frame J' J', containing the drop wires; therefore, by drawing down the rail H' H', the shaft K' K' turns round, and causes the straps L' L', to raise the frame J' J' so far as to lift all the drop-wires above the top of the plate Z, which keep their places by the tension of the yarn, as soon as the machine gets into full operation. In

lifting the drop-wire frame  $J' J'$ , it also draws up the point  $M'$ , of the small lever  $M' N'$ , Figs. 151 and 153, which causes the other extremity  $N'$ , to operate upon an arm of the upright rod  $F'$ , and turn it round as fast as to let the belt lever  $G'$ , shift the driving belt from the loose, on to the fast pulley : at the same time another arm  $O'$ , of the upright rod  $F'$ , Fig. 151, also operates upon the rod  $D' D'$  at  $P'$ , Fig. 150, and shifts it to the right hand, until the point  $C'$  of the lever  $B' C'$ , drops into the square groove seen in Fig. 150 : the lever or catch  $C'$ , is kept in the groove of the rod  $D' D'$ , by the small spiral spring  $Q'$ . Thus by pulling forward the rail  $H' H'$ , the drop-wires are lifted, and the whole machine is instantly put in operation ; and by lifting the catch  $C'$ , the rod  $D' D'$  being operated upon by the spiral spring  $E'$ , it is instantly stopped.

Figs. 152, 153 &amp; 154.

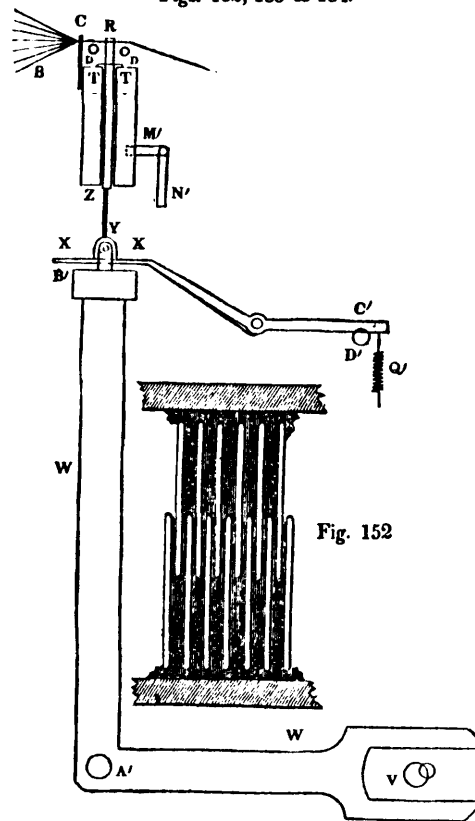
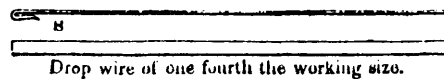

Fig. 152

Fig. 154.



Drop wire of one fourth the working size.

Fig. 152 is a front view of the guide reed E, seen in Fig. 151, for directing the yarn on the beam F: it consists of a piece of sheet iron cut into a number of slits, corresponding to the number of threads to be warped on the beam. By examining the figure, it will be seen that the slits are so contrived, that a lease may be formed on each beam if necessary.

In looking at the representations given of this machine, those unacquainted with it might be apt to suppose, from the number of levers, springs, &c. depending upon each other, that it would work inaccurately, and be difficult to keep in order. This, however, is not the case. The warping machines used in Great Britain require the utmost attention on the part of the attendant to notice instantly when a thread breaks; as should her eye be diverted from her work but one moment, the end of a broken thread might wind round the beam so far, as to require five minutes or more to find it, and put the machine again in motion. But this is not the case with those used in America; for while the machine is in operation, the attendant is frequently behind the bobbin frame, taking out empty spools, and supplying their places with full ones; nor could the cradle warpers of America be used, except by being furnished with a self-acting stop-motion. This motion is, therefore, eminently entitled to the appellation of an important labour-saving improvement.

The above account of the American spooling and warping machines, is principally abridged from the able descriptions given by James Montgomery, Esq., in his excellent work, entitled, "The Cotton Manufacture of the United States of America contrasted and compared with that of Great Britain."

We close this part of our subject with a remark or two regarding the warping and beaming of silk webs:—

1st. In warping silk webs where the warp is to consist of different grists or colours of yarn, as in stripes, ginghams, pullicates, &c., the bobbins must be arranged in the creel or bank agreeably to the order in which they are indicated in the draught or design.

2d. A silk warp to make taffeta, must not be put on the same roller or beam with one to make gros de Tours serge, satin, &c., but each must have a separate and distinct roller for itself; and they must be weighted according to the nature of the texture to be produced.

3d. A warp making the same pattern in several places in the web, but double-threaded in one place and single in another, must not be all put on the same roller or beam; because, the different

parts would not work equally tight in the weaving, as the double-threaded part would be much larger on the roller than the single.

#### SIZING.

Since the invention of the common dressing or sizing machine, in 1802, by Mr. Thomas Johnson, an ingenious mechanic of Bredbury, a great many different contrivances have been tried to facilitate the operation of sizing; but most of them have sunk into oblivion. It will be our object, in this place, to describe only those which are likely to prove beneficial to the manufacturer. The first of these which we shall consider, is of the invention of Mr. John Potter, of Manchester; and the second, of Messrs. Hornby and Kennyworthy, manufacturers, Blackburn.

Mr. Potter's improvements in the process of preparing warps for the loom, consist; firstly,—In certain variations in the construction of the ordinary dressing machine, by means of which, the manufacturer is enabled to dress warps which have previously undergone the process of sizing,\* so as to produce a warp more capable of enduring the subsequent friction in the process of weaving; and, secondly, In the construction and arrangement of a new machine for the purpose of producing a warp of greater length, and thereby obviating the necessity of joining or twisting in the warp so frequently as is the case when a warp of the ordinary length is used. The same letters and figures of reference indicate the same parts throughout.

Fig. 1, Plate 3, represents a side elevation of a dressing machine to which part of these improvements is applied; and Fig. 2, is a plan of the same. In operating with this machine, it is usual to place the yarn on six or eight beams, from which it is drawn off and combined in the process of dressing to form the warp; but in Mr. P's machine, the warp, in a ball (as taken from the drying house,) is placed at the point A, and the end of the warp, in a sized state,

---

\* The common sizing machine consists of a trough filled with size, through which the warp is drawn; but instead of passing the warp simply through the size, it is made to pass under and over a series of rollers, having suitable gudgeons and bearings at their ends, rotary motion being communicated by the friction of the travelling warp as it is drawn away from them. After having passed this series of rollers, the warp is squeezed between two large wooden rollers or cylinders, which expel the superfluous moisture. It is then passed over the cylinders of a common drying machine, similar to those used by calico printers, when it is finished.

Fig. 4.

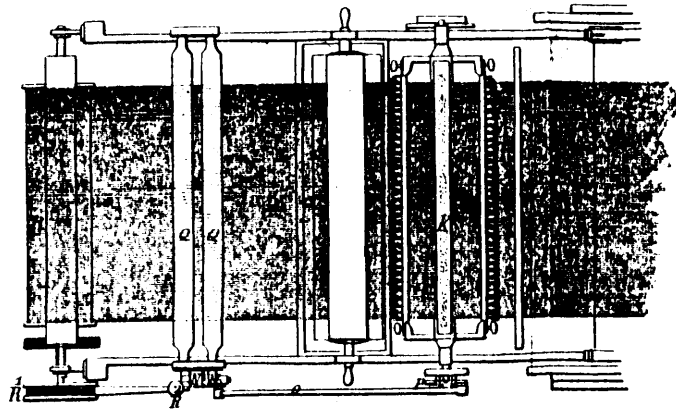

Fig. 5.

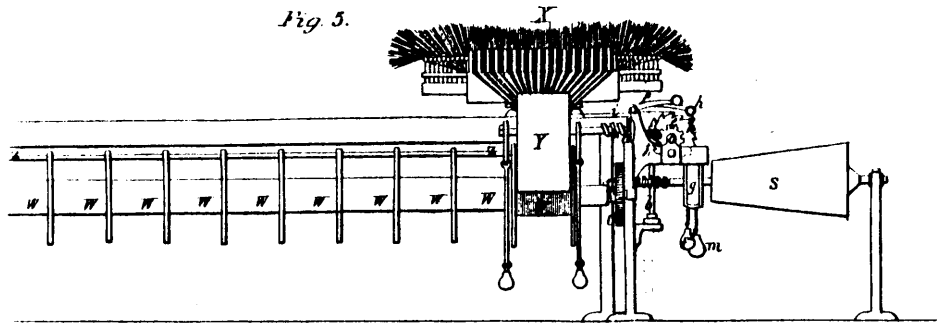

Fig. 7.

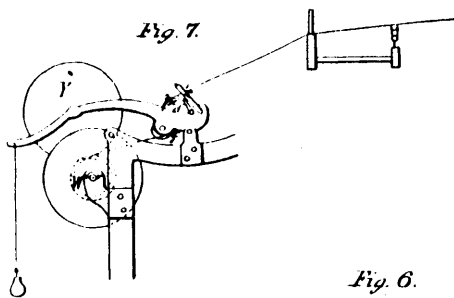
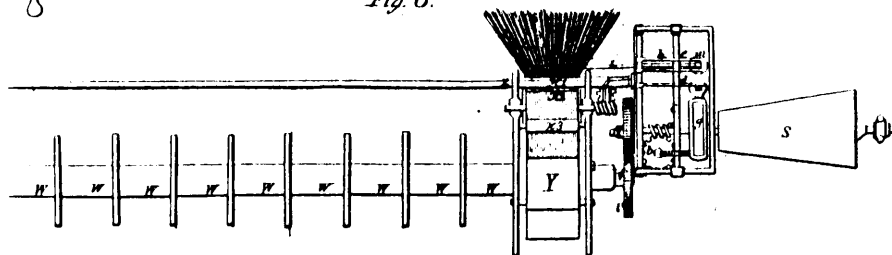
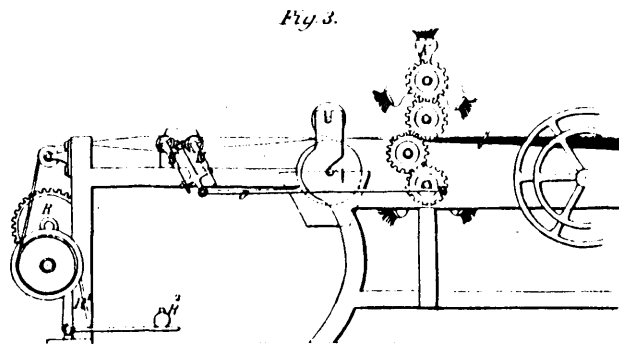
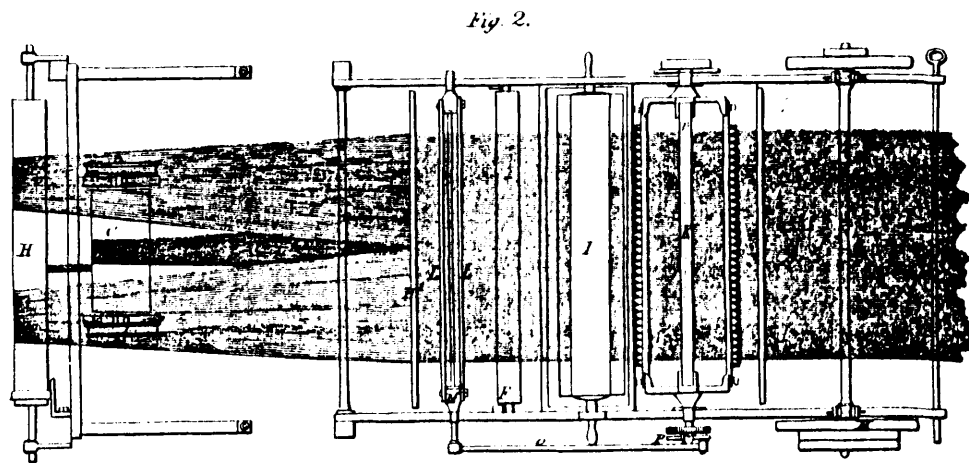
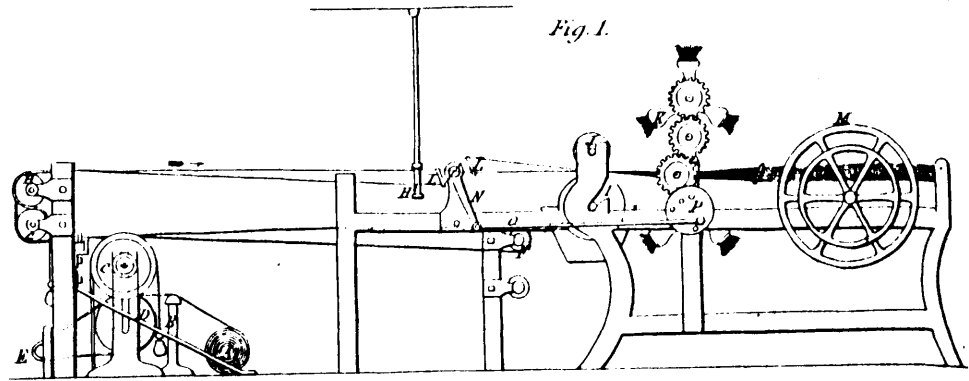

Fig. 6.





is carried over the rest or guide B, and between the pressing rollers C and D, thence round the stud E, and back under the roller D, passing again between the pressing rollers C and D, and over the upper surface of the roller C. From this point it is carried forward over the rollers F, G and H, till it arrives at the horizontal position, where it is traversed in the direction of the arrow through the ravel H', suspended from above, so as to yield to any impediment which may arise in the warp, and forward, between the stiffening rollers I, I, whence it proceeds under the brushes K, and is taken up on the warping beam of the loom, as in the ordinary dressing machine. M, is the driving pulley, and motion is imparted to the various parts in the common way. Now it is well known to weavers and persons conversant with the preparation of warps for the loom, that the adhesion of various threads of sized warp, would cause great difficulty in passing it through this machine with any degree of regularity. To obviate this difficulty and separate every thread, two rods L L, are passed through the openings of the lease which has been secured at the warping machine, as best seen at Fig. 1. These rods L L, are attached to the shaft or rod M', (see Fig. 2,) through which they receive an alternating motion from the arm N, which is vibrated by the connecting rod O, driven from an eccentric on the face-plate P, as seen in Fig. 1, where the varying position of the rods L, will be seen dividing the threads or ends of the warp in its progress towards the rollers I I. In Fig. 4, the process of opening or separating each thread of the warp is effected by means of the two blades Q Q, which move on centres at their respective extremities, and are vibrated by the arms N N, as in Figs. 1 and 3. The warp in a sized state, being placed on the beam R (Fig. 3) in the ordinary manner, practised with sized warps and held back by the friction strap and weight R<sup>1</sup> and R<sup>2</sup>, which gives off the warp at a proper tension as the dressing proceeds. The vibrations of the rods L L (Figs. 1 and 2) and the blades Q Q (Fig. 4) in these machines depend on the revolution of the eccentric P (Fig. 4,) which may be driven at a speed of 210 revolutions per minute; but the speed may be varied according to the nature of the work in the machine.

Fig. 5, represents an elevation; Fig. 6, a plan; and Fig. 7, a side view of a machine for forming the warp on a beam previous to the sizing process. In this machine, S (Figs. 5 and 6) represents a cone drum, which is driven by means of a strap, the velocity varying according to the diameter on which the strap is placed. On the extremity of the shaft on which the cone S is fixed, is attached a



spur-wheel **T** (Figs. 5 and 6,) which drives the spur-wheel **U**, fixed on the end of the shaft **V**, carrying a succession of small beams **W**, divided by the flanges. On to these beams **W**, the warp is received from the heck **X**, as seen at Fig. 5, and regularly distributed by means of a small ravel **X'**, which is traversed by a worm and worm-wheel, as shown in Fig. 6, and in side view at Fig. 7, where the direction of the yarn will be seen passing over the guide roller **X<sup>2</sup>**, and under the roller **X<sup>3</sup>**, and thence to the beam **W** (Fig. 7,) at the same time that it is compressed into a hard state by the cylinder **Y**, which acts as a pressing roller during the operation. This pressing roller **Y**, along with the arms in which it is supported, move freely on the rod **Z Z** (Figs. 5 and 6,) so that as soon as the first small beam **W**, is full, the operator raises the presser **Y**, and passes it forward to the next, and so on till the whole series of beams **W**, are filled and equally pressed, at the same time securing a lease in the yarn of each beam, as already alluded to, for the action of the rods **L L**, or **Q Q**, in the dressing machine. It will be also remarked that the heck **X**, is moved in the frame in which it is supported, so as at all times to correspond with the position of the presser **Y**, when placed on any of the various beams **W**, in the process of filling. Returning to the cone shaft which carries the wheel **T**, will be seen a small worm *a*, driving a worm-wheel on the upright shaft *b* (Fig. 5,) which is also provided with a worm driving a worm-wheel on the horizontal recording shaft *c*. This shaft *c*, carries two circular discs *d* and *e*, the position of which will be seen in Fig. 6. The disc *d*, is provided with a small lever which rests upon it during the winding process of the cone **S**, and the speed of the disc *d*, is so calculated as to make one revolution during the winding on, or filling one of the beams **W**, with warp, but when that is effected a notch or gap in the disc *d*, allows the lever *f*, to fall by means of the weight *f'* (Fig. 5) which tightening a strap-break on the pulley *g*, placed on the cone shaft, arrests the revolution, and thereby distributes an equal quantity of warp on the various beams **W**, as they are filled in succession. The disc *e*, is provided with a series of notches or gaps, and supports a lever *h*, which acts on the marking rod *i*, by means of a spring *o*, placed on the perpendicular rod by which the weight *m*, is supported (see Fig. 6.) The extremity of the opposite arm of the rod *i*, passes under the edge of the warp, and is provided with fibrous material, saturated with marking ink which marks the warp every time the lever *h*, is allowed to fall into one of the notches in the disc *e* (see Fig. 5,) into which it is forced by the weight *m*, at the same time the marking

rod *i*, having made the mark, is replaced in its former position on a stud or rest, by the action of a spiral spring *o* (Fig. 5,) the mark on the warp, indicating a uniform and equal amount of warp placed on the beam *W*. The distance of the notches on the disc *e* (Fig. 5,) are calculated to compensate for the increasing diameter of the warp on the beam *W*, during the filling process. The varying taking up of the warp on to these beams *W*, according to their increased circumference, is compensated for by traversing the driving strap to a larger diameter of the cone *S* (Figs. 5 and 6,) and the velocity must depend on the nature of the work and the judgment of the operator. By tracing the action of this warping machine, it will be obvious that the beams *W*, may be multiplied to any convenient extent, and consequently the length of the warp, which necessarily effects a great saving in joining or twisting in, as practised in the ordinary warp.

In Fig. 6, it will easily be perceived, that motion is transferred from the cone drum *S*, to the yarn beams *W*, by the spur wheels *T* and *U*. The notched disc *e*, is left out in the plan view (Fig. 6,) to avoid confusion, and more clearly to show the levers *e'* and *d*, weight *m*, and marker *i*. Should the marking apparatus shown in Figs. 5 and 6, be considered too complicated, one of those in common use may be easily substituted in stead.

We now pass on to describe Messrs. Hornby and Kennyworthy's machine for sizing and preparing warps for the loom; which, from its neatness, the regularity of its motions and the work which it is capable of performing, is well worthy our attention in this place.

The improvements in this machine, consist in a novel and particular arrangement of mechanism for sizing and preparing warps from "beam or machine warping."

The principal feature of novelty and improvement in Messrs. H. and K's. method of sizing or dressing warps, consists in a peculiar mode of distributing or laying out of the threads, so that they shall be dressed or sized in parallel strips or breadths, laid in even and close contact, side by side, and usually termed "beers or half beers" in the ordinary warping mill. (See common warping mill, Section First.)

This new method of dividing and laying out the warp threads into strips, bands, or beers and half beers, *during the process of sizing and preparing them for the loom*, possesses many advantages, which will be evident to persons conversant with the ordinary modes of conducting such operations. As the threads are divided into certain numbers, forming a beer or half beer, and in that

breadth passed through the sizing substance, they retain the form of bands or strips, and are slightly attached to each other by the adhesion of the size, thus forming narrow tapes or breadths of warp threads, and consequently rendering them more tenacious than if passed through the sizing and preparing process in single threads, as commonly done, and allowing them to be more easily conducted through the machinery. The warps may be thus extended to a much greater length than usual, and the process of taking the "lease" and winding on to the warp beam ready for "looming," can be effected by the arrangement of one and the same machine, with more expedition than by the ordinary method now in use.

One of the improvements connected with the working of the machinery, is a new arrangement of the headles for obtaining the lease or cross shed of the warps, previously to the dressing, sizing, or drying of the same, that is placing the headles, for dividing the shed of the warps, *at the entrance end of the machine*, or at the commencement of the operation; and the further improvements in the machinery for sizing and preparing warps, consist *in a novel form of ravel or comb*, for allowing the lease band to pass through the warps without the necessity of having the whole of the half beers or breadth relaid each time of taking such lease or cross shed; and also in the application of a *revolving self-acting marker*, for marking off any required length of warps, as they are wound on to the warp beam, ready for looming.

In Plate IV, Fig. 1 represents a plan or horizontal view of the machinery in which these improvements are shown; Fig. 2, is a side elevation; and Fig. 3, a vertical section of the same, taken longitudinally through the middle of the machine. The main and side framings of the machinery are shown at *a, a, a, a*, which support the beams of warp or yarn *b, b, b, b, b*, previously wound and prepared by the warping machine: these main side frames also support the various ravels or combs, headles, sizing or dressing trough, the drying cylinders, tension and guide rollers, and also the driving apparatus for giving motion to the mechanism.

It will be perceived, that as the unsized warps proceed from their respective beams *b, b, b, b, b*, they are guided on to, and passed through an ordinary ravel or comb *c, c*, and thus divided equally, prior to their being passed through the headles *d, d*, situated at the entrance of the machine, for the purpose of effecting the cross shed, and thereby taking the lease previously to the yarns being submitted to the sizing process. The lease now being taken, and the cross band or threads introduced, for the purpose of looming or drawing

in of the warp through the headles, as is well understood, the yarns or warps are passed through a ravel or comb *e*, (see Figs. 1 and 2,) formed by a rack of teeth or pins and intervening spaces, for the purpose of dividing and laying the warps in parallel breadths, side by side, and forming each division, strip or band of warps, (of any required number,) into separate and distinct tapes or sheets, (of any desired width,) each thread being laid parallel, side by side; and thus, in close lateral contact, the ravel or comb *e*, either being allowed to vibrate or oscillate freely as the warps proceed over it, or it may be caused to revolve, if found more desirable.

The continuous warps being thus made or separated into breadths or bands *A*, are now passed over a conducting roller, and immersed into the trough or vessel *f* (see Fig. 3,) which contains the sizing material, and is to be kept in a heated state, by steam passing through the pipe *g*, *g*, or otherwise, and thus boiled into the warps as they pass through it, and under the tension rollers *h*, *h*, (see Figs. 1 and 3): it will be observed that these tension rollers *h*, *h*, may be adjusted to any degree of tension, or raised up entirely out of the troughs, to be cleaned or otherwise, by turning the winch handle 11 (see Figs. 1 and 2,) which, by means of the worms and wheels 12, and pinions 13, 13, take into the racks 14, 14, in connection with which the pivots of the rollers *h*, *h*, are mounted. The warps are then to be passed forward through a pair of squeezing rollers, *i*, *i*, (Figs. 2 and 3) and again immersed in the trough or vessel *j* (see Fig. 3,) containing a similar sizing preparation, to finish the yarns; from thence the warp is passed around the drying cylinders *k*, *k*, (Figs. 2 and 3) also heated by steam through the pipe *g*, and discharged by the pipes *l*, *l*, or by any other convenient means. The yarn or warps, as they pass around these drying cylinders, will now be found to assume the form of tapes or bands, as the sizing material will cause the parallel threads, as they lay side by side, to adhere slightly together, and thus proceed in a tape-like form, being of course much stronger, more regular, and less likely to be broken or disarranged, than in the ordinary mode of sizing.

A brush 15 (Figs. 1, 2 and 3,) is placed over the yarns as they proceed over the cylinders *k*, for the purpose of dressing and laying the fibres of the threads, and making the tapes or bands more compact and even: it is caused to revolve very slowly by means of the small band 16 (Fig. 2,) proceeding upon the axis of the guide roller *m*, (Figs. 1 and 2;) the warps now proceed in a sized, dried, and finished state, conducted by the rollers *m*, *m*, through a similar ravel or comb *n*, *n*, (Figs. 1 and 2,) but of a finer rake or pitch

than the ravel *e, e*, and by passing through or over which, the strips or bands are turned edgewise, and again similarly dividing by the oscillating or vibratory action of this comb *n, n*, and laid over the tension roller *o, o*, (Figs. 1, 2 and 3,) in a proper state to be received and wound upon the warp beam *p*, ready to be removed and taken to the loomer or drawer in. The continuous operation of the machinery is effected by means of a strap passing around the driving pulley *q*, (see Figs. 1, 2 and 3,) upon the end of the transverse shaft *r* (Fig. 1,) being traversed from the loose pulley by the setting on rod *s*. Upon the shaft *r*, is also a conical drum *t*, having a driving strap passing around it, and the corresponding cone *u*, (Figs. 1 and 2,) mounted also upon a transverse shaft *v*, at one end of which there is a toothed pinion *w*, (Fig. 1,) driving the train of spur wheels *x, y, z*, which gives rotary motion to the warp beam *p*, causing it to wind on the yarn or warps as required. The yarn is kept distended and even, by means of weighted friction bands being passed around the ends of the warp beams *b, b*, and the pressure of the squeezers or presser rollers, is similarly adjusted, by means of the weighted lever 2 (Fig. 2.) The self-acting marking apparatus is shown in Fig. 1; upon the end of the revolving guide roller *o, o*, is a small worm 3, taking into a worm wheel upon the end of the shaft 4, at the reverse end of which is the mitre wheel 5, driving a corresponding wheel 6, upon the small shaft 7, which carries the revolving marker 8, which from time to time dips into a colour box, and marks the warp threads with a patch of colour as it revolves, any length for the pieces intended to be woven, and allowing the warp beam to contain accurate lengths, without waste in the looming.

In the detached Figs. 4, 5 and 6, are shown three varieties of the improved ravel or comb, (upon a large scale,) for dividing or separating the warp, as they pass through the machine. Fig. 4 shows one description, being that preferred to be used with a pendulous or oscillating motion; Fig. 5, another, which is preferred to be used as a rotary comb, and it will be perceived, that one set or rake of teeth will always be entering and dividing the warps, as those on the opposite leave them; Fig. 6 shows another modification of the same, which may either be used with a rotary or any other required motion.

If our manufacturing friends shall derive any real benefit from the description just given of these improved machines for preparing warps for the loom, we will not grudge the expense incurred on our part in rendering all the particulars as plain as possible.

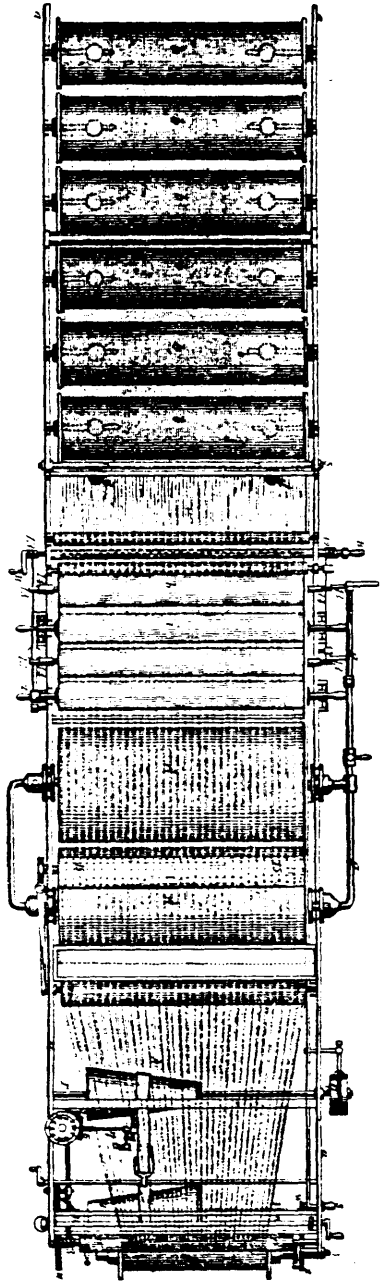

Fig. 2.

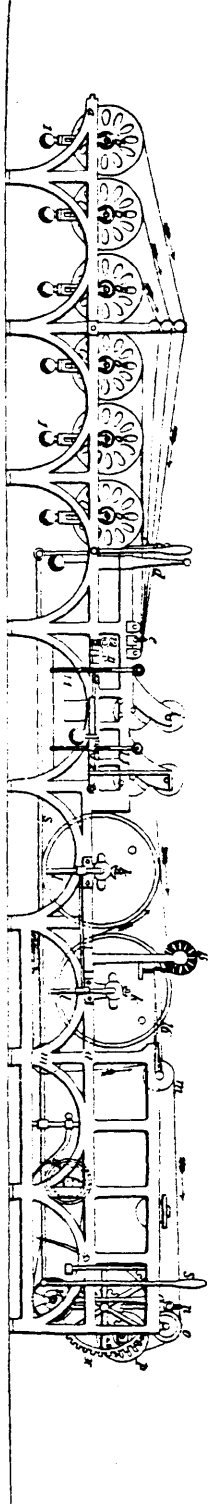
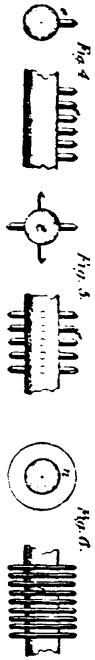
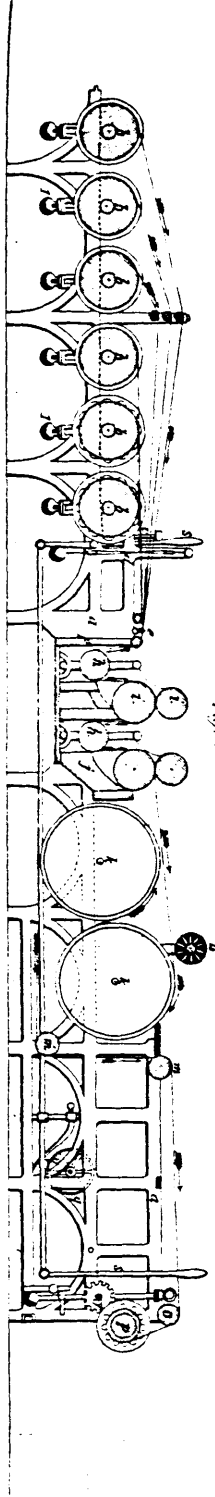

Fig. 3.



## SECTION TENTH.

### PLAIN WEAVING BY POWER.

Now the steam begins to blow ;  
Girl, haste, your loom attend ;  
Do not always be so slow,  
Or your web will have no end.

Stay no longer idly singing :  
You're a pretty girl, indeed !  
Hark ! the factory bell is ringing !  
Mary, to your loom with speed !

See the shafts begin to move,  
Driven by the power of steam ;  
Wheels below and wheels above  
Turn correctly every beam.

Force is constantly supplied,  
Brought by straps of leather strong ;  
Levers play on every side,  
While the shuttle shoots along .

See how fast the lay is driven ;  
See the treadles sink and rise ;  
See how well the cloth is woven ;  
Gracious ! how the shuttle flies !

BRIEN DHU O'FARRELL.

We shall not in this place give any repetition of the old hacknied story regarding the origin of the power loom (in Europe),\* by Mr. Edmund Cartwright, of Marnham, Nottinghamshire ; and for which he obtained a patent, bearing date 4th April, 1785. It is certain that this machine would have long since passed into oblivion, had it not been for the improvements made upon it by other men of genius. It was not until the year 1801 that power loom weaving began to be extensively introduced for the manufacture of plain goods ; and not until the years 1830 to 1834 that it was successfully applied to light fancy fabrics, with small patterns, (say, of from 10 to

---

\* For the true origin of power loom weaving (plain, tweeled and figured, of every description) see introduction to this work, page 5, 20 to 37, and 61.

75 changes of design.) Since 1834, it has been still further improved by various ingenious individuals, both in Europe and America, so as to make it available in the manufacture of almost every description of figured textures, whether of cotton, silk, linen or wool. In the present section, we shall confine ourself to laying before our readers its application to the weaving of plain fabrics.

Fig. 155.

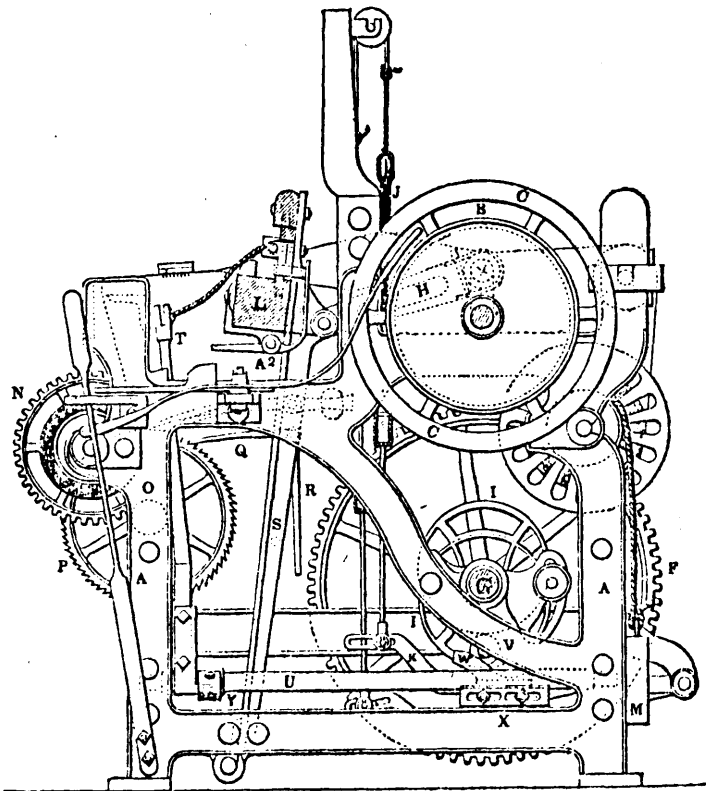

Fig. 155 shows a side view in elevation of the power loom, as constructed by Messrs. Sharp, Roberts & Co., Manchester; but as their machine contains no particular feature of novelty, we shall not waste much time upon it. Fig. 156 is a section of the same taken through the centre, showing the interior working parts of the machine.

A is the frame work of the loom; B, belt pulleys (Fig. 155); C, fly wheel for equalizing irregularities of motion during the working of the machine: D (Fig. 156,) driving spur-wheel, fixed on the



crank shaft E, and gearing into the wheel F; this wheel F, has double the number of teeth of the spur wheel D, and consequently makes only half as many revolutions: it is keyed, or made fast, on the end of the cam shaft G; and it is by means of this shaft, in connexion with suitable tappets and levers, that motion is communicated to the headles for the purpose of shedding the warp, as well as for giving motion to the shuttle. The cranks of the driving shaft are connected to the swords of the lay by arms H (see Fig. 155.) The cams J J, give motion to the treadles K K, which work the headles J J, as will be seen very plainly in Fig. 156. The yarn beam is

Fig. 156.

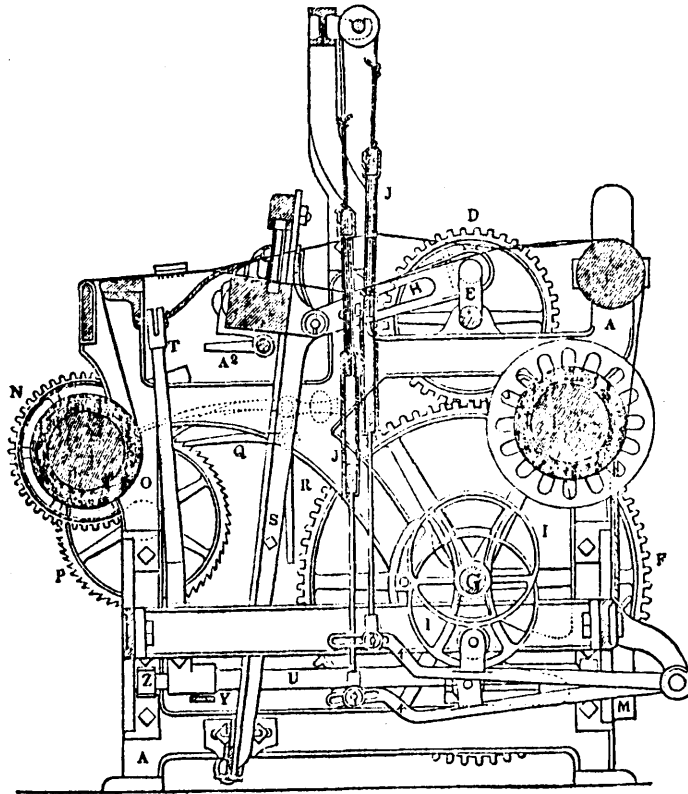

weighted in the ordinary manner used for coarse goods, namely, by passing a rope round the circumference of each end, to which rope a friction weight M, is attached. The cloth roller and take-up motion (as any practical manufacturer will perceive) possess no feature of novelty, consisting merely of a spur wheel N, working into a pinion

O, which pinion is made fast to the ratchet wheel P, and this wheel receives motion from the clicks or drivers Q, by means of the arm R, this arm receiving motion from the stud-pin S, fixed in the sword of the lay L. The shuttle is thrown by means of two levers T (one of which is seen in Fig. 155 and the other in Fig. 156,) connected at bottom with the horizontal shafts U, motion being communicated to these shafts by a wiper V, working against the iron shoe or slide W, (see Fig. 155.) The shoes or slides W, are bolted to the side of the horizontal shafts U (one at each side of the machine) at X. The picker staves or levers T, are recovered to their original positions, alternately, after having thrown the shuttle through the shed, by means of a leather strap and spiral spring which connects the horizontal shafts U U, together across the machine; the position of one end of this leather strap, as bolted to the horizontal shaft U, will be seen at Y, in both Figs. The shaft U, has suitable bearings at each end, which are indicated by the dotted lines in Fig. 155, and at Z, Fig. 156. The protector A<sup>2</sup>, as seen in both these Figs. is of the ordinary construction. This form of the power loom being unworthy of further notice, we shall, therefore, pass on to describe others of greater merit proceeding gradually until we arrive at the most perfect.

Fig. 157.

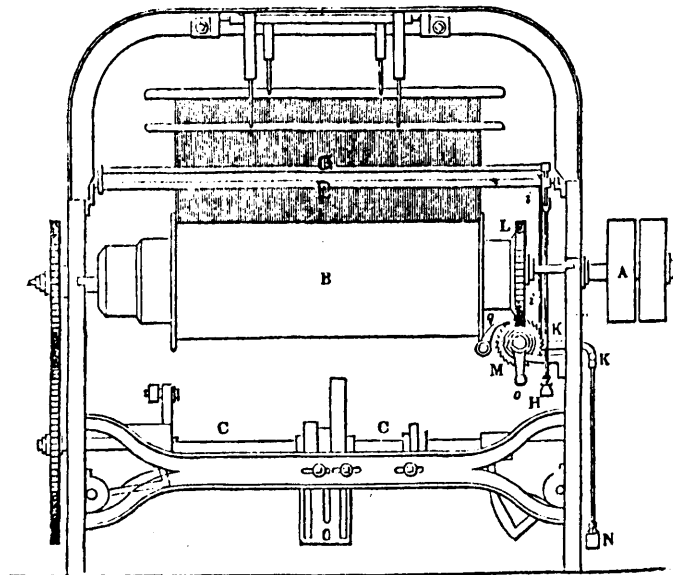

Figs. 157, 158, 159 and 160, show the different parts of a loom, as improved by Messrs. Apelles Howard, of Stockport, and John Scattergood, of Manchester.

Fig. 157 is a back view of the common loom; Fig. 158, a side view, in which part of the framing is removed for the purpose of making the application of the improvements more obvious; and Fig. 159, a view of the improvements apart from the loom, for the purpose of showing more clearly the nature and construction of the same. In Figs. 157 and 158, some of the ordinary parts of the loom are omitted, and only such parts delineated as we consider requisite to explain and show the position in which the improvements are applied.

In Fig. 157, A, represents the driving pulley keyed on the crank shaft, which gives motion to the lay; B, the yarn beam; D, Fig. 158, the cloth roller; and C, the tappet shaft by which the position of the headles is regulated, thereby producing the shed or opening in the warp for the passage of the shuttle at each vibration of the lay. In Figs. 157 and 158, E represents a shaft

Fig. 158.

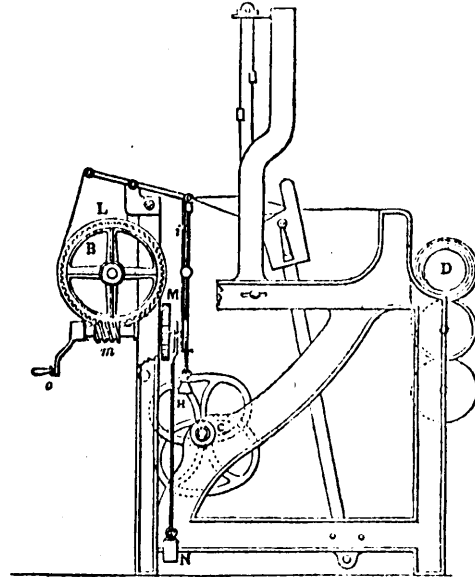

supported at each side of the loom, parallel to, and immediately above the yarn beam B: on this shaft is made fast two arms F, and F'. The extremity of the arm F, carries a shaft G, similar to that marked E, and crossing the loom in the same way: the shaft E

moves freely on its axis. The direction of the warp threads from the yarn beam B, will be seen in Figs. 158, 159 and 160, proceeding first over the shaft or roller G, and under the shaft E. To the arm F', is suspended a small lever or rod which supports the weight H, as best seen in Figs. 158 and 159; this arm also carries a perpendicular rod *i*, which moves freely through an opening or hole in the lever K, beneath (Figs. 157 and 158.) L, represents a worm-wheel attached on the axis of the yarn beam B; and *m*, a worm or screw taking into the wheel L (Figs. 157 and 158.) On the same shaft which carries the worm or screw *m*, is placed or keyed the ratchet wheel M, and also the vibrating lever K, which is not keyed but perfectly free, sliding in a suitable slot. The lever K, is provided with a catch or dog *q*, taking into the ratchet wheel M, (Fig. 157,) and at the other extremity with a rod suspending the counter weight N, as seen in Fig. 158. By retracing the action of the various parts which we have last described, it will be obvious that any amount of warp can be given off by revolving the yarn beam B, by means of the worm *m*, in one direction, while it will be taken up; or, the reverse will be produced by the opposite motion of the worm *m*; and further, that the position of the shaft G, will vary or vibrate according as the warp is taken up, or given off by the yarn beam B. Suppose, for example, the warp to be wound up to a given point, by means of the small handle *o*, the shaft G, will assume a certain position, and the amount of tension to which the warp is subjected will depend upon the amount of counter weight H, which has a constant tendency to elevate the shaft G, as best shown at Figs. 158 and 159. Under these circumstances, as soon

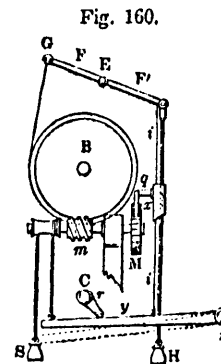
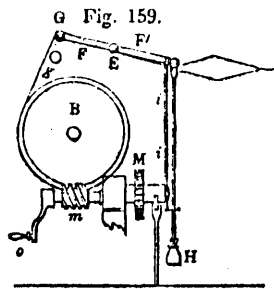

as the loom is put into action and the regular vibration of the lay proceeds, the cloth which is produced will be taken up on the cloth roller D, and consequently the warp which passes

over the shaft G, will have a tendency to depress that shaft, although the tension will not materially vary, on account of the counter weight H, always remaining the same. But as soon as the take-up of the cloth roller has proceeded so far as to depress the shaft G, to the position indicated by the letter *g*, (Fig. 159) the rod *i, i*, elevates the lever K, which is connected to the catch or dog *q* (Fig. 157,) and thereby gathers a tooth in the ratchet M, which, on the return of the lay, is carried forward by the counter weight N, and actuates the yarn beam B, which gives off the amount of warp required. This train of movement is shown separate in Fig. 159; by which, together with the foregoing description, it will be obvious that the regular take-up of the cloth on the roller D, as it is produced, is provided for by a commensurate giving off of warp from the beam B, caused by the depression or varied position of the shaft G, as already explained. In weaving cloth of a fine quality, the arrangement represented at Fig. 160 will act rather more uniformly than that already described. In this figure, the arrangement of parts does not vary from that already stated, excepting that in the place of the weight N, and vibrating lever K, the catch or dog *q*, is placed on a stationary fulcrum *x*, and the rod *i, i*, is carried downwards and attached by a small spring to the lever *y*, which moves freely on a fixed fulcrum at *z*. This lever *y*, is placed under the tappet shaft C, and when a sufficient quantity of yarn is given off from the beam B, the small wiper *r*, does not interfere with it, but as soon as the rod G, is depressed by the tightening of the warp, as already described, the lever *y*, is raised and comes in contact with the wiper *r*, which immediately depresses it, and rotates the ratchet wheel M, by means of the band and tightening weight S, with which it is connected; this band being passed round the small drum or barrel placed on the same shaft that supports the ratchet M.

The shafts G, and E, should be well polished, so that the warp yarn, in passing under and over them, may not be chafed.

This contrivance, for giving off warp yarn and actuating the taking-up of the cloth, does not possess any particular feature of novelty which we can recommend, in a practical point of view, to the cotton manufacturer. For the manufacture of silk goods the shafts G, and E, might be used with advantage, provided that another shaft, similar to that marked G, was inserted at the point of the arm F', cutting away the connecting rod *i, i*, and all the other parts of the apparatus shown in the Figs. These three shafts, acting on the warp threads, would keep them

equally tight on both sides of the shed ; which will be obvious after a word of explanation.

Suppose, for example, that the warp, in coming from the beam B, is passed over the shaft G, under the shaft E, and over that fixed at the point F', and from thence into the headles ; it is evident, that while the shed is forming, the rollers at the extremities of the arms F, and F', will be raised or depressed in proportion to the strain caused by the shedding of the warp, the vibratory action always compensating by yielding at the point where the greatest strain is caused, that is to say, when the shed is full open, as shown in the Figs., and acting as a distender on the warp in proportion as the shed closes after the passage of the shuttle (taking up the slack.) Looms mounted with this contrivance, in connection with the vibrating reed take-up motion, shown at Fig. 169, would, we have no doubt, be found advantageous in weaving delicate yarns. (See Figs. 219 and 220.)

“ Nature in her productions slow, aspires  
By just degrees to reach perfection's height:  
So mimic art works leisurely, till time  
Improve the price, or wise experience give  
The proper finishing.”

Manufacturers have, as is well known, experienced great inconvenience in regulating the relative motions of the yarn and cloth rollers in the loom ; and although many attempts have been made to remedy this evil, yet for the most part they have totally failed in accomplishing the desired object. The few that have partially succeeded, have been attended with so much expense as to prevent their coming into general use. The improvement now offered is such that it can be added to power looms of all descriptions at a very trifling expense, and we think will completely remedy the evil, at least so far as cotton stuffs are concerned. It was first found available we shall be glad, as it first originated with us in the year 1835, but a patent for which was granted to Mr. Edwin Bottomley, of South Crossland, in the parish of Almonbury, county of York, clothier, bearing date Sept. 30th, 1838, prior to which date we tested the invention for over two years at M. Philippe's machine shop, 19 Rue Chateau Landon, Paris, France.

In these drawings the same letters of reference indicate the same parts.

Fig. 161, represents a back elevation of a loom of the ordinary construction, to which the improvements are applied ; Fig. 162, is

a side view of the same ; Fig. 163, is a plan of the improved mechanism, and Fig. 164, a side view of it.

Fig. 161.

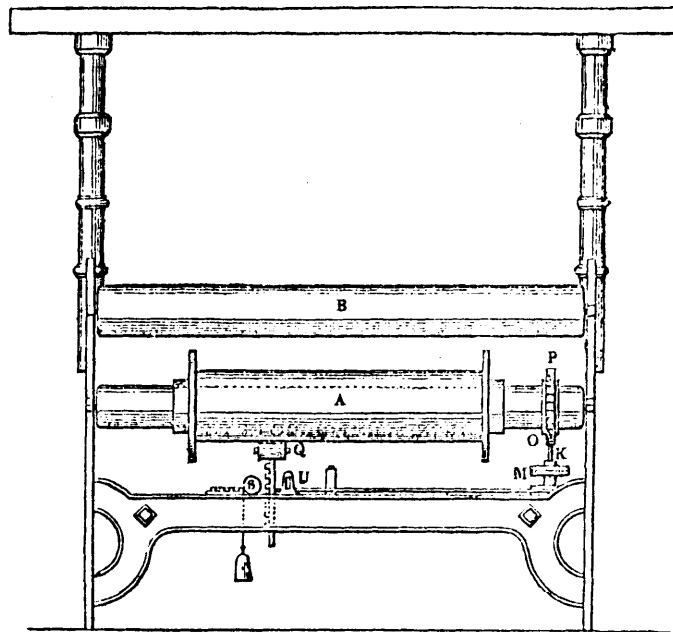

The yarn beam A, is placed in the usual position, and contains the warp which passes over the roller B: after the warp is woven it passes over the breast beam C (Fig. 162) and is taken upon the cloth roller D. On the shaft E (Fig. 163) is placed a cylindrical eccentric F F, which imparts alternating movement to the forked piece G G. This forked piece G G, embraces the eccentric F F; and its arm or connecting bar is provided with a slot through which one of the arms of the bell-crank lever H H, passes (Fig. 163.) To the opposite arm of the bell-crank lever H H, is attached the connecting rod I; and this rod communicates motion to the lever J, which vibrates on the centre of the upright shaft K. The lever J, is furnished with a small stud or pin in which the pinion L, and also the ratchet wheel M, revolve; these wheels, being connected with each other, the small pinion L, is geared into the spur-wheel N (Fig. 163.) fixed to the shaft K (see Fig. 161.) To this shaft is also keyed the worm O, which actuates the worm-wheel P, and consequently the yarn beam A, on the axis of which the worm-wheel P,

is placed. Thus the rotation of the shaft E, imparts to the yarn beam a giving off motion, in a ratio corresponding with the number of vibrations of the lay; but it is obvious that a greater length of warp yarn would be given off the larger diameter of a full beam than where the diameter is reduced; hence it is required that the yarn beam increase its speed of rotation as the diameter becomes less, thereby insuring an equal quantity of warp given off at each beat of the reed against the cloth, whatever may be the diameter of the yarn beam.

Fig. 162.

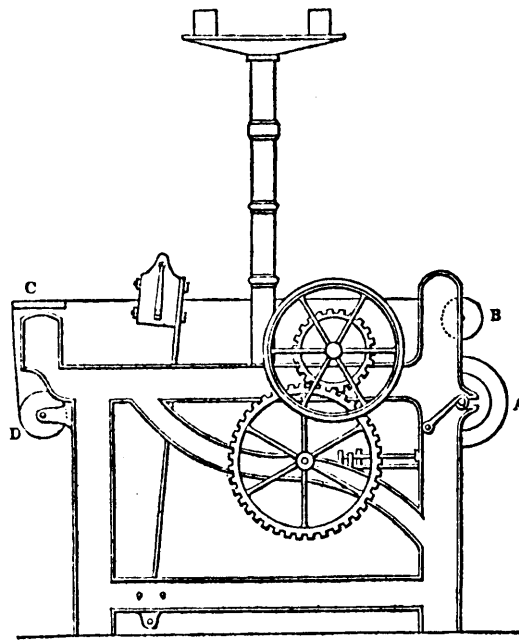

We shall now proceed to describe how the required increase of speed to the yarn beam A, is effected. A small roller of wood or other suitable material Q, is supported, as shown in Fig. 161, by a sliding-piece R, moving freely in a slot in the frame-work of the loom, as shown in Figs. 161, 163 and 164; fixed to this support, is a rack continuing downwards and working into the pinion S, (Fig. 163) at the opposite extremity of which is another pinion T, (Fig. 161) working into the rack attached to the sliding carriage U. On the shaft R, (Figs. 162, 163 and 164) is a small pulley provided with a cord, to which is suspended a weight, for the purpose of



keeping the roller Q, constantly pressing against the under side of the yarn, as shown in Fig. 161. By this contrivance, the reduction in the diameter of the warp on the yarn beam, as it is consumed in the weaving process, allows the roller Q, to rise, which conveys a traverse motion to the carriage U, in the direction of the

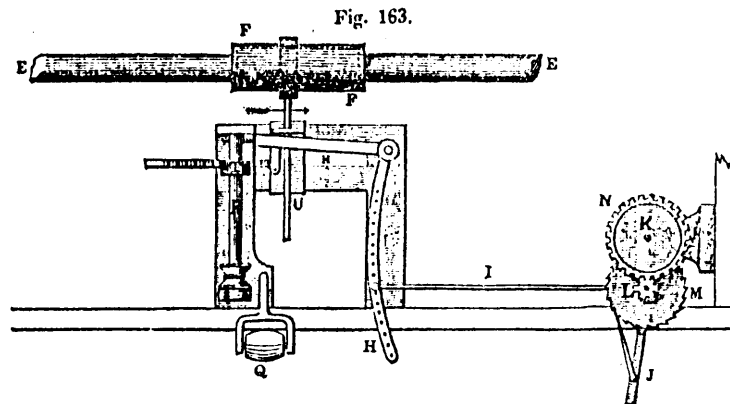

arrow, Fig. 163, and brings it nearer to the centre or fulcrum of the bell-crank lever H H, which has the effect of increasing the range or space through which the opposite arm of the lever vibrates, and thus producing an increased vibration in the lever J, by means of the connecting rod I, which by means of the dog or catch V, (Fig. 163) gathers more teeth in the ratchet wheel M, and consequently increases the speed of revolution of the yarn beam A, thereby compensating for the decreased diameter, as already explained, and thus an equal and uniform delivery is effected during the whole of the weaving process, without reference to the length of the warp that may be rolled on the yarn beam. On the arm of the bell-

Fig. 164.

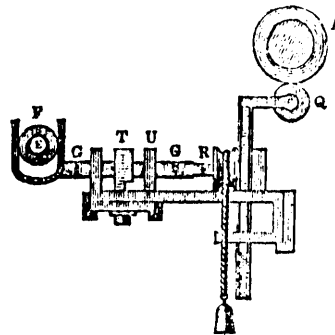

crank lever HH, to which the connecting rod I, is attached, will be seen a series of small holes, and it is by connecting the rod I, to any one of these holes, either nearer or further from the fulcrum of the bell-crank lever HH, that the amount of vibration of the take-up lever J, is determined, and either greater or less amount of warp yarn is delivered from the beam after each vibration of the lay, according to the nature of the fabric to be woven.

From the foregoing explanation, any practical power loom weaver will have no difficulty in comprehending the improvement.

Figs. 165, 166, 167 and 168, represent an improved power loom for weaving light textures, invented by Amassa Stone, an extremely ingenious mechanic of Johnstone, Rhode Island. By means of this improvement, whenever, from the accidental breaking or non-delivery of the weft, the striking up of the reed meets with little or no resistance, the delivery of the warp, and also the taking-up of the cloth, is suspended, although the general evolutions of the loom continue.

Fig. 165.

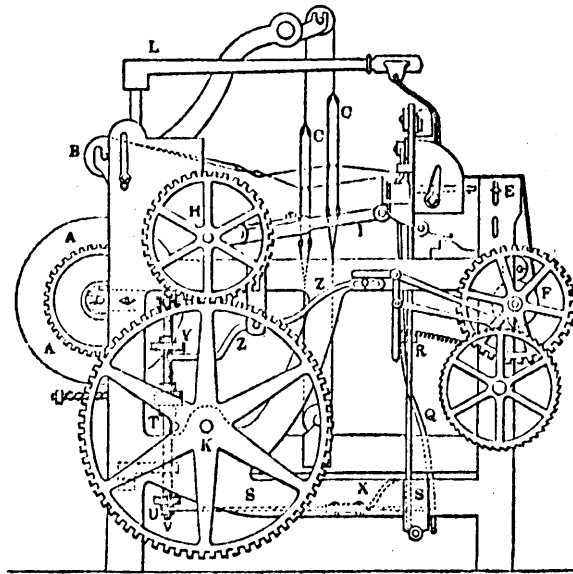

Fig. 165, is a side view of the loom, with the novel parts attached, and in working order; Fig. 166, is a profile representation of the same, showing particularly the novel parts; Fig. 167, is a vertical section, taken through the loom at right angles to Fig. 165,

in the line looking toward the cloth beam; Fig. 168, is a vertical section, also at right angles to Fig. 165, in the line looking in the opposite direction, that is, toward the warp beam; and No. 30, Fig. 167, is a horizontal view of a portion of the lay of the loom, taken at that end where the improved parts are connected; the respective letters of reference pointing out the same parts in all the figures.

The yarn beam A, is mounted on the side framing of the loom in the usual way. From this beam the warp threads pass over a whip roller B, above, and thence through the headles C, C, and reed D, in the ordinary way. The reed is mounted in the lay in a frame, which is capable of vibrating on pivots or centres, for the purpose of allowing the reed to fall back when it strikes forcibly against the weft thread in beating up. The cloth produced by the intervention of the warp and weft threads in the front of the reed, passes over the breast beam E, to the cloth roller F, and is wound upon a loose roller G, by the friction of their surfaces.

The crank or driving shaft H, by which the working parts of the loom are driven, is connected by the crank rods I I, to the back part of the lay; and hence, as the crank shaft rotates, the latter is made to vibrate in the usual way; and by the ordinary connexion of toothed wheels, the tappet shaft K, is also driven, which works the headles C C, that open the sheds of the warp, and also the picker staves I. I., that drive the shuttle to and fro.

Fig. 166.

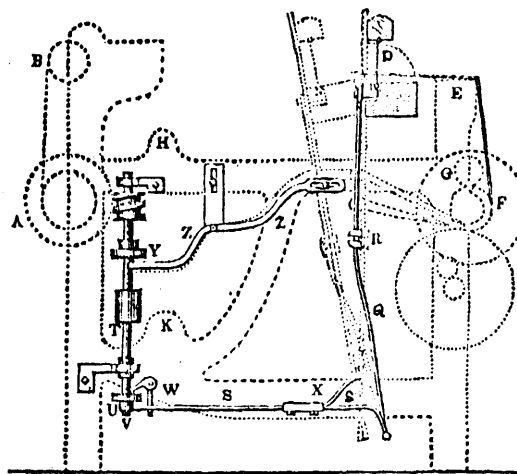

In the representation of the back of the lay at Fig. 167, it will be perceived that the reed D, is fixed in a frame MM; which frame is mounted in the lay, and held by pivots on studs NN, bolted to the upper parts of the swords of the lay. Upon these studs or pivots N, the reed, with its frame, is enabled to swing backward, but it is confined in its situation by powerful springs O O, secured to the back of the lay, the ends of these springs pressing against the lower rail of the reed frame. The tension of these springs may be tempered by the adjustable staples and screws P P.

These parts of the loom are described for the purpose of leading to, and more readily illustrating the design and operation of the present improvement.

A perpendicular lever Q, is attached to the side of one of the swords of the lay by means of a fulcrum stud R, projecting from a bracket bolted to the sword. The upper end of this lever bears against the bottom rail of the back of the reed frame M, and is held there by a slight spring (see Fig. 167.) The lower part of this frame is attached by an axle joint to a horizontal rod S. That end of the rod S, to which the lever Q, is connected, is bent downward, as shown in Fig. 166, for the purpose of enabling the rod to pass over the rocker at bottom of the sword, which the lay vibrates upon. The joint connecting the end of the lever Q, and rod S, must be brought as nearly in coincidence with the axle of the lay as may be found practicable.

Fig. 167.

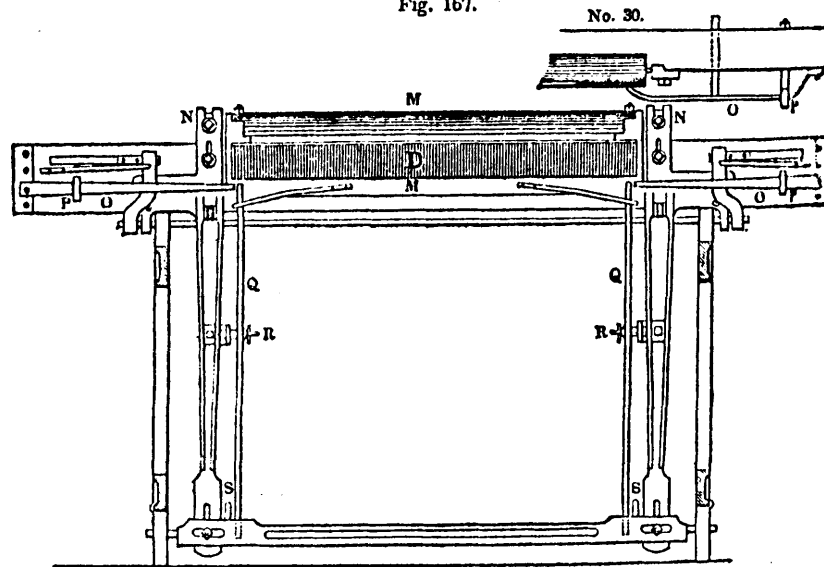

At the back part of the loom there is a perpendicular shaft T, supported in brackets bolted to the side frame or standard. Upon the upper part of this shaft is fixed an endless screw or worm taking into the teeth of a wheel on the yarn beam; by the rotation of which worm the beam is turned, and made to deliver the warp. A ratchet wheel U, is made fast by a bolt to the perpendicular shaft T, near its lower end; and below this a cylindrical piece or collar V, is loosely fitted upon the shaft, and held up by a pin.

Fig. 168.

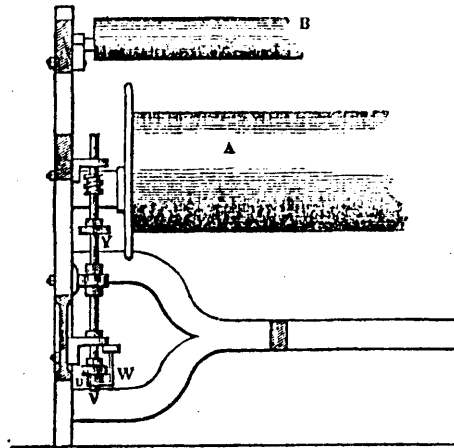

From this side of the collar V, a small arm extends, carrying an upright stud, which passes through an eye at the back end of the horizontal rod S, for the purpose of forming a jointed support to that end of the rod. At a short distance from this joint, a standard W, is fixed into the horizontal rod, carrying a click or tooth, the point of which drops into the teeth of the ratchet wheel. This tooth is the driver that gives rotary movement to the ratchet wheel U, and shaft T.

A bent arm X, is affixed by bolts to the horizontal rod S, the elevated end of which arm being struck by the sword when the lay falls back, gives a sliding movement to the rod S, and thereby causes the click W, to drive the ratchet wheel U.

Below the endless screw on the perpendicular shaft T, another ratchet wheel Y, is fixed, corresponding in the number of its teeth with the ratchet wheel U. This ratchet wheel acts upon a tooth at the end of the shorter arm of a bent lever Z, Z, suspended on a pivot or stud in a bracket attached to the side frame. At

the reverse end, that is, near the extremity of the longer arm of this bent lever Z, a tappet pin is fixed, for the purpose of raising the arm of the ordinary taking up lever, which works the click or driver of the ratchet connected with the ordinary train of toothed gear, for taking up or winding the cloth upon the beam in front, as usual.

After every flight of the shuttle through the open shed or warp, the lay advances for the purpose of causing the reed to beat up the weft thread ; but as it is mounted in a vibrating frame M, the force with which it strikes against the cloth causes the lower rail of the reed frame to recede or swing back from the lay a short distance, as shown in the section Fig. 166.

As the upper end of the perpendicular lever Q, bears against the lower rail of the reed frame whenever the reed frame recedes, as above described, that end of the lever is necessarily forced back, and the under end consequently moved forward, bringing with it the horizontal rod S. This movement of the rod S, causes the end of the bent arm X, to be brought close against the vibrating sword of the lay, and also draws back the click W, over one tooth in the ratchet wheel U. On the return of the lay into the inclined position, as shown by dots in Fig. 166, the sword will strike against the end of the bent arm X, and slide the horizontal rod S, back again, which will cause the click W, to drive the ratchet wheel U, one tooth, and thereby turn the shaft T, and its endless screw, by means of which the yarn beam is drawn round, and the warp given out.

But in the event of the weft thread having broken, there will be no delivery from the shuttle, and consequently a want of filling to the cloth ; the reed, therefore, in beating up, will not meet with that resistance which it did when the filling of the weft thread was perfect. In the beating up of the lay, therefore, the reed frame will not now be driven back as before, nor the lever Q, be sufficiently acted upon to cause it to slide the horizontal rod S, through the same distance : consequently, the click W, will not be drawn over another tooth of the ratchet wheel U, and the shaft T, being thus allowed to remain in a quiescent state, the warp will no longer be given out from the yarn beam.

The rotary movement given to the shaft T, in the way described, carries round the ratchet wheel Y ; and the teeth of this ratchet wheel acting upon the tooth at the end of the shorter arm of the bent lever Z, causes that end of the bent lever to be depressed every time that a tooth of the wheel Y, passes over the tooth of the lever, as shown by dots in Fig. 166.

By these means, the reverse end or longer arm of the lever is

raised, which causes the tappet pin fixed near its extremity to lift the take-up lever, which operates upon the ordinary gearing for winding up the cloth on the roller as usual. But when the rotary movement of the perpendicular shaft T, is suspended, owing to the breaking of the weft thread, as before stated, then the taking up of the cloth ceases, as well as the delivery of the warp, although the loom continue in action.

To a superficial observer, this contrivance of Mr. Stone's might appear to be the very acme of perfection; yet, it possesses many defects, in a practical point of view. In the first place, it is of too complex a character: indeed, all that it accomplishes, can be effected with one-fifth of the machinery which it contains. Mr. S's. loom is not capable of producing thin goods with any degree of regularity; and this will be evident when it is remembered, that it is by the accumulating pressure of the cloth against the reed that motion is communicated to the yarn beam. It is clear, therefore, that for light muslins, or delicate silk textures, where only from 10 to 25 threads of weft per inch are required, this contrivance would not answer at all; unless Mr. S. hung his reed upon a *wisp*, and employed, *in conjunction*, a native of the Emerald Isle, to assist, by coaxing the warp from off the yarn beam as fast as required. The cloth, instead of being taken up regularly *as the weaving proceeds*, is wound up by *fits and starts*; for it is not until a number of threads of weft have been added to the face of the cloth, *equal to the length of one of the teeth in the ratchet wheel U*, on the end of the perpendicular shaft T, that the click or driver W, is allowed to fall into a new tooth; and after this has taken place, it will keep jiggling or dancing there, until another ridge of cloth is *piled up against the reed*, when the point of the click W, will again hop over a tooth, as before.

In order to make this loom weave thin goods perfectly regular, it would be absolutely necessary to have the teeth of the ratchet wheel U, as fine as the diameter of the weft thread to be used; but we question whether teeth of this fineness would not be more than a match for the eye-sight of any manufacturer in the United States. For textures having from 35 to 80 threads of weft per inch, however, Mr. Stone's loom will be found an acquisition.

Fig. 169, represents part of the frame of a loom, with the common ratchet take-up motion attached thereto, as well as an improved method of governing it, receiving motion from a vibrating reed, which is arranged in a frame, precisely the same as that shown in Figs. 165, 166, 167 and 168. The improvement now to be de-

scribed, although exceedingly simple, is capable of effecting all that Mr. Stone's apparatus can accomplish.\*

Fig. 169.

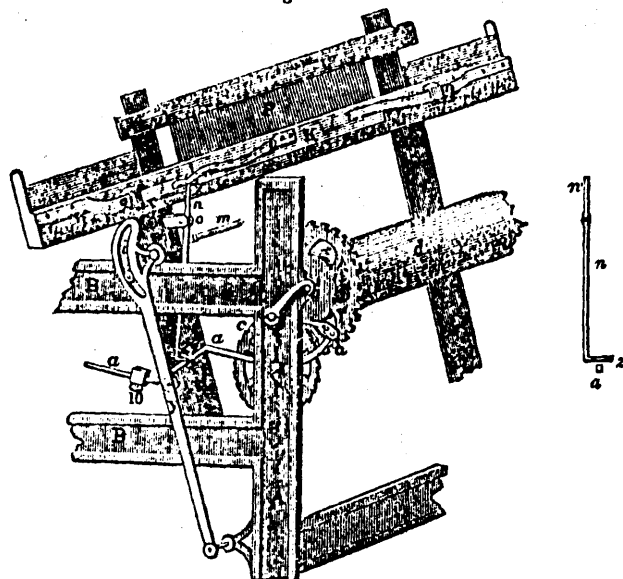

ABBC, is the frame of the loom; *w, w*, the lay; P, the reed; *g, g*, two springs, for the purpose of keeping the under part of the reed frame K, pressed up. The springs *g, g*, are screwed by two screws at each end, as will be perceived by the black dots at the points *w, w*, and are governed, in regard to their pressure against the rail K, by means of two clasp bolts passing through the lay; which clasp bolts may be seen close to the letters *g, g*; these bolts have regulating nuts, one at the back and the other at the front of the lay, for the purpose of setting the bolts to any required position, according to the degree of pressure intended to be communicated from the springs *g, g*, to the rail K, of the reed frame. In the operation of the loom, the rail K, is pressed back by the reed P, at each vibration of the lay, a distance equal to the diameter of the weft thread. *n, n*, is a lever having its fulcrum at *o*, the upper end of which lever is kept pressed against the rail K, at the point X, by means of the spring *v*; and this spring is made fast to the rail K,

\* The connexion between the reed and the yarn beam is not absolutely necessary; because, a uniformity of tension may be communicated to the warp from the cloth roller.



by two screws, as indicated by the black dots.\* At the lower end of the lever *n, n*, is a turned-up part *z*, which touches the inclined part of the arm *a, a, a*: this arm has its axis at *V*, and carries at its end a click or driver *e*, for giving motion to the ratchet wheel *c*, which wheel has a pinion made fast to it, and taking into the spur wheel on the end of the cloth roller *d*: the ratchet wheel *c*, is prevented from recoiling by a suitable catch fixed inside the frame, its point working into the teeth of the ratchet a little to the right of the letter *c*.

The vibrating motion of the lay is effected through the agency of a stud-pin carrying a small roller which works in the sweep *i*: this stud-pin is connected to an arm on the end of the driving shaft *m*.† When the loom is put in operation, the reed *P*, is forced back by the web in the act of beating up; and as the web acts on the lever *n, n*, and makes its lower end to strike against the arm *a, a, a*, so as to put the cloth roller *d*, in motion, it thus winds on the texture as it is woven; but if the reed beats up without the web, it will not in that case be forced back, as there would not be any addition to the cloth, by the crossing of the web, to that which had been previously beaten up; the reed, therefore, would not be forced back by the subsequent motion of the loom, and consequently the lever *n, n*, would not strike against the inclined face of the arm *a, a, a*, and, of course, the taking-up apparatus would not be set in motion.

The inclined arm *a, a, a*, has a small governing weight *10*, at its end, which serves to balance it and keep the click or driver *e*, against the tooth in the ratchet wheel *c*: but this weight *10*, is not sufficiently heavy to cause the ratchet wheel *c*, to revolve. The sword of the lay carries a small roller or pulley fixed on a stud-pin, as shown a little above the letter *y*; this roller serves to elevate the inclined arm *a, a, a*, after it has been depressed by the action of the turned-up end of the lever *n, n*, upon it, in the manner already explained; so that in the backward motion of the lay, the roller will raise the arm *a, a, a*, and will thereby cause the click *e*, to fall back into a new tooth in the ratchet wheel *c*; in which tooth it will remain, until the lever *n, n*, has received sufficient motion from the point *X*, to cause the other extremity to depress the arm *a, a, a*, and

\* A patent for this invention (Fig. 169) was granted to Oliver C. Burr, an ingenious mechanic, of Milbury, Mass., bearing date July 17, 1835.

† The figure being drawn in perspective, only one of the swords of the lay, with its sweep *i*, can be seen; but the opposite side of the lay, of course, has a similar sword with a sweep *i*: no difficulty can be experienced on this head.

force the ratchet *c*, forward a distance equal to that which the catch *e*, had fallen back in the previous working of the loom.

Before commencing the operation of weaving, the lever *n, n*, must be so set in relation to the inclined arm *a, a, a*, that when the reed is brought full up to the face of the cloth, the turned-up end of the lever *n, n*, will nearly touch the inclined face of the arm *a, a, a*; and when the lay is thrown full back, the roller will not touch the under side of the arm, because the arm had not been previously depressed by the lever *n, n*. In this position, therefore, the loom may continue to operate for ever without any motion being communicated to the ratchet wheel *c*, unless weft be added to the face of the cloth. It will be perceived, that a very slight addition of weft to the cloth (say two or three threads) will communicate extensive motion to the arm *a, a, a*; and this is caused by the greater leverage of the lower end of the lever *n, n*. For looms of the working size, the length of the lever *n, n*, from the axis *o*, to the rail *K*, is 5 inches, and from the axis *o*, to the other extremity, or turned-up end, 17 inches; but these relative lengths may be varied to suit the different heights of looms. It is very evident, therefore, that this improvement or contrivance, is not only simpler, but superior to Stone's motion, and possesses the advantage over it, of taking up the cloth with greater regularity; because, the action of the lever *n, n*, is direct on the arm *a, a, a*, at each pick of weft; *three threads of weft at most being sufficient to communicate action to the arm a, a, a*; it is, however, not perfect, on this very account, being liable, to a certain extent, to the same defect experienced in Stone's mechanism, namely, the piling of the cloth against the reed before any motion at all can be communicated. For shirtings and calicoes, of from 30 to 80 or 90 threads of weft per inch, this motion is, perhaps, the best in existence at the present day; and the expense of fitting it to a loom is only a few shillings.

"The invention is mine," said a would-be inventor;  
 "You lie," said a second, "I own 't, and no other;"  
 A third cried, "'tis mine!" with a voice loud as Stentor;  
 And a fourth swore 'twas his; while a fifth was its father.

Figs. 170 and 171, exhibit another method of regulating the movement of the yarn beam, and of taking up the cloth, so as to produce textures of uniform thickness throughout: but this contrivance contains the same defects as those pointed out in Mr. Stone's

loom ; upon which loom it is, indeed, a direct infringement, although it possesses the merit of being somewhat simpler.\*

A, is the lay ; B, the spring reed ; C, a lever, extending down nearly as low as the bottom of the lay sword ; D, the part of the lay in which the bar F, slides ; F, a perpendicular shaft, having a ratchet wheel G, at its lower end, and an endless screw or worm H, on its upper end which operates, by gearing, to give the requisite motion to the yarn beam as in Stone's loom ; I I, steps of the perpendicular shaft ; and J, a guide piece, having a notch or mortise in it to receive and guide the bar E, which acts upon the ratchet wheel G.

Fig. 170.

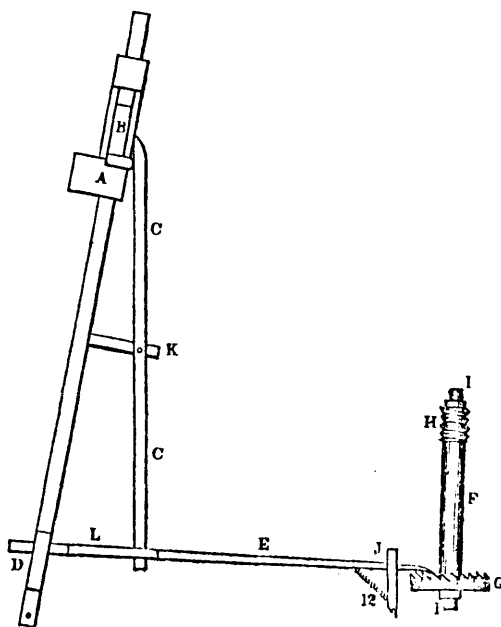

The following is the manner in which the bar E, receives its motion from the spring reed B:—

When the lay advances and brings the reed into contact with the

---

\* This *alteration* of Stone's loom, notwithstanding its similarity to the original, was made the subject of a patent by one Welcome A. Potter, of Cranston, Rhode Island, Nov. 23, 1837; which circumstance goes far to prove what we have time after time stated, that there is in reality no more protection for the ingenious man in the United States of America than in Great Britain.

cloth, the springing of the reed throws the top of the lever C, back, being actuated by the resistance of the face of the cloth against the reed, and as this lever works upon a fulcrum K, in the lay, and its lower end passes into a mortise or slot at L, in the bar E, and bearing against the fore end of this slot, draws the rod forward by the back motion of its upper end, and the back end of the bar E, then catches upon a tooth of the ratchet wheel G, to which wheel it will give motion when the lay is thrown back: this force is effected by the sword of the lay coming into contact with a shoulder at M, thus forcing the bar E, back and turning the ratchet wheel G, the shaft F, then moving the yarn beam by means of the worm or screw H.

The foregoing description represents the bar E, as receiving its motion through the agency of the spring reed: but Mr. Potter says that he sometimes communicates it through that of the spring whip roll, as shown in Fig. 171.

The whip roll N, is supported by a bent arm O, there being a similar one at its other end; the bent arm O, works on a fulcrum P, made fast to the frame of the loom, said bent arm extending to about an equal distance from the fulcrum at each end. A spring Q, acts upon the lower end of the bent arm, for the purpose of holding it in its proper position when not acted upon by any other force.

When the lay moves forward, and the reed presses forcibly on the cloth, this has the effect of drawing the whip roll N, forward, and causing the lower end of the bent arm O, to recede: from this lower end, a rod or wire R, extends to a lever S, working on a fulcrum T, on the frame of the loom, its lower end passing into a mortise or slot in the bar E; and this lever is operated upon in a manner similar to that of the lever C, already described: in both Figs. the mortise L, must be long enough to give play to the lever E, without moving the lever C, (Fig. 170) or the lever S, (Fig. 171).\*

On referring to Mr. Stone's machine, Figs. 165, 166, 167 and 168, and comparing it with Mr. Potter's modification, shown in Figs. 170 and 171, the real character of the infringement will be manifest. In the first place, Mr. Stone's invention consists, in the

---

\*The whip roll N, in connexion with the lever O, for the purpose herein explained, is not the invention of Mr. Potter, Mr. Louis Schwabe and other manufacturers, of Manchester, having used it several years before the date of his patent; and these gentlemen, *no doubt*, can tell Mr. Potter to whom the invention truly belongs!

Fig. 171.

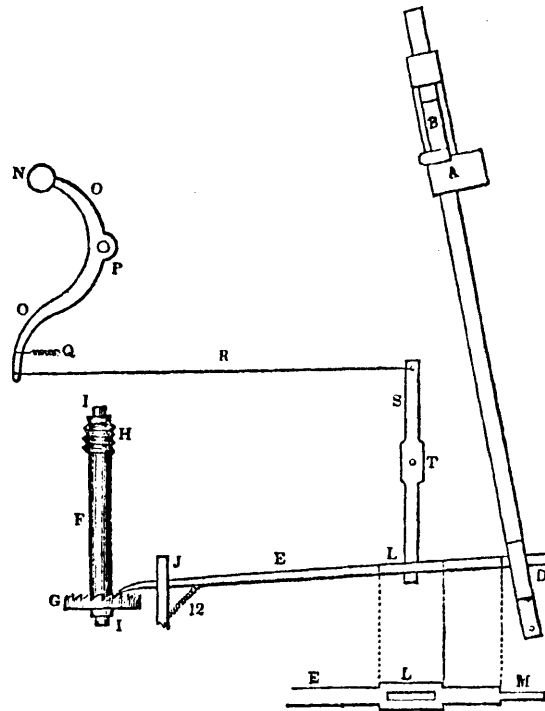

application of the lever Q, in connexion with the rod S, having the bent arm X made fast to it, the click W, ratchet wheels U, and Y, vertical shaft T, and the worm working into the spur wheel A A, on the end of the yarn beam (see Figs. 165 and 166;) and these parts, receiving motion from the vibrating reed D, govern the giving out of the warp, as well as the taking-up of the cloth, the one depending upon the other. This feature forms the subject of Mr. Stone's patent; and, we think, with justice too; for the contrivance is really very ingenious, and does its inventor credit, notwithstanding its inapplicability to *some kinds of textures*, as has been already stated.

Now, on referring to the subject of Mr. Potter's patent, as shown at Figs. 170 and 171, it will be seen that he has adapted the let-off and take-up motions claimed by Mr. Stone; for his worm H, shaft F, ratchet wheel G, bar E, lever C, and so forth, are precisely the same; but he evades Mr. Stone's patent by substituting a mortise or slot L (see Fig. 170) in the rod or bar E, instead of the bent arm X, bolted to the rod or bar S, of Stone's loom (see Figs. 166.) Into the slot L, made in the bar E, Mr. P. inserts the end of the lever

C, instead of connecting it by a pin to the end of the rod or bar S, as in Figs. 165 and 166; and it is the playing of the lever C, against the ends of the slot L, (receiving motion from the vibratory reed) that rotates the ratchet G, on the end of the shaft F' (Fig. 170,) instead of the piece X, and so forth, in Stone's loom. Mr. P. makes a catch of the rod or bar E, for turning the ratchet G, instead of inserting a stud-pin into the rod, and putting the click W, on it, as in Fig. 166: but this alteration, of course, amounts to nothing. The jogged end M, of the bar E, in Figs. 170 and 171, answers the same purpose as that shown in Figs. 165 and 166, but is no improvement thereon. The spiral spring 12, in Figs. 170 and 171, is attached to the bar E, and stationary guide J, for the purpose of keeping the bar E, against the teeth of the ratchet G, until sufficient cloth has been woven to cause the under extremity of the lever C (Fig. 170) to draw back, towards the cloth, the bar E, so as to allow its point to drop into a new tooth in the ratchet G: all this justly belongs to Mr. Stone, as any man who is not a downright ignoramus may at once perceive. The modification of Fig. 170, shown in Fig. 171, does not possess any merit, and is only another method of beating about the bush, for the purpose of evading Stone's patent. How in the world Mr. Potter obtained a patent for Mr. Stone's invention, is to us a mystery: surely somebody about the Patent Office must have been magnetized when this transaction took place.

Fig. 172, represents a side view, in elevation, of a common power loom, with another modification of the same apparatus for regulating the taking-up of the cloth; and for which contrivance, a patent was granted to Horace Hendrick, of Killingly, Conn., bearing date 22d Sept. 1836; but it is not worth a \$1,000; and our only object in having gone to the expense of drawing, engraving, &c., and giving it insertion in this work, is, to expose that system which is so extensively carried on by men who have no real talent of their own and are too lazy to get their living by honest means. Mr. H. denominates his appendage, "the rod and sickle;" but we think the term *pruning hook* would be quite as applicable.

F F' F' F, is the frame of the loom; H H, the sword of the lay; R R, the lever which receives motion from the vibrating reed, and is the same as that marked Q, in Figs. 165, 166, 167 and 168, n, n, in Fig. 169, and C, in Figs. 170 and 171. The lever R R, in this loom is made to beat up against the inclined rod X, at its lower extremity, near its fulcrum, this rod X, being connected to the arm of the common take-up lever (which is in all respects like that

Fig. 172.

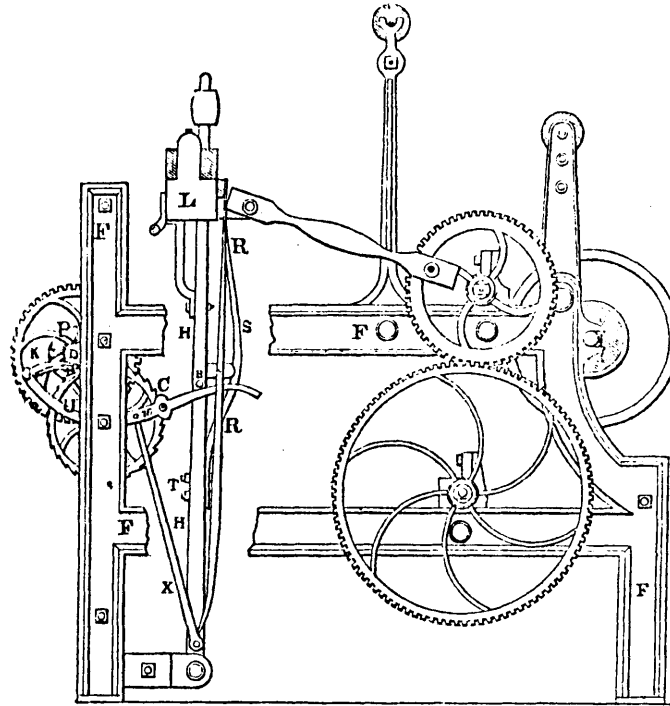

shown at Fig. 169.) L, is the lay; B, a small friction roller or stud-pin fixed on the side of the lay, like that above the letter *y*, in Fig. 169, except that in this case it is turned upside down, for some purpose *best known* to Mr. H. himself. The arm C, being acted upon by the roller B, will, of course, cause the clicks or drivers K, to turn the cloth roller P. S, is a spring (one at each side of the lay) bolted to the sword of the lay at T, for the purpose of keeping the reed frame in its place, as in Stone's loom, and in the others also, but here it is turned topsy-turvy.

Wherewith does the reader suppose the subject of this patent consists? Is it in the lever RR? Is it in the springs S? Or, is it in the clicks K? The only feature of novelty that we can perceive, is in the beating of the nib or under extremity of the lever RR, against the lower part of the connecting rod X, and that too so near its fulcrum that something in the neighbourhood of a horse power, at least, must be required to enable it to actuate the taking-up of the cloth; and this, in our opinion, is improving *backward*.

The rod X, (Fig. 172) being connected by a stud-pin to the lay

sword at bottom and to the arm C, at top, constitutes a positive take-up motion ; and consequently the lever R R, which is actuated by the reed, is useless. Neither do we see the utility of the stud-pin or roller B ; because, the rod X, will raise and depress the arm C, which carries the clicks or drivers K, independently of it. The patentee does not tell us how the lever R R, actuates the arm C, through the agency of the rod X, but simply remarks that “the lever R R, communicates motion to the cloth roller by means of the rod X, connected to the *sickle* C.” He also says that “the roller or stud-pin B, may be inserted in the lever R R, instead of in the sword H H ;” but, we confess our inability to see the utility of so doing, unless the under extremity of the lever R R, were cut away altogether : after which, the motion would be in all respects like that shown at Fig. 169 ; for if the stud-pin B, were made fast to the lever R R, underneath the arm C, and the roller or stud-pin B, on the lay sword above it, it would answer the same purpose as the turned-up end of the lever *n, n*, shown in Fig. 169, with the roller fixed on the sword of the lay below it. But, in this case, it would be necessary to shorten the distance between the reed and the fulcrum of the lever R R, so as to bring the fulcrum nearer to the reed, as in Fig. 169, in order to give the other extremity greater scope for acting on the arm C. Instead of this, however, Mr. H. informs us, that the fulcrum of the lever R R, is midway between the reed and its lower extremity.

As this contrivance is represented, it will only operate as a positive take-up motion, as before stated ; and in order to make it actuate the arm C, through the agency of the vibrating reed, the rod X, must be disconnected from the pin *w*, and a long slot made in the end of the rod X, into which slot the pin *w*, may work ; this pin *w*, having a suitable head made upon it, to prevent the rod X, from dropping off. This done, if the arm C, is counterbalanced with a weight, similar to that marked 10, in Fig. 169, the roller or stud-pin B, will depress it.

In this position, the lower nib or point may possibly actuate the rod X, in forcing up the arm C, when a sufficient quantity of cloth is piled up against the reed ; but even then we think the odds against the lever R R, will be tremendous, from the relative positions in which these parts are represented by the patentee.

“Emulation,” says Mason, “like the other passions of the human mind, shows itself much more plainly, and works much more strongly in some than it does in others. It is in itself innocent ; and was planted in our natures for very wise ends, and, if kept up-



der proper regulations, is capable of serving very excellent purposes, *otherwise it degenerates into a mean and criminal ambition.*

“When a man finds something within him that pushes him on to *excel in worthy deeds, or in actions truly good and virtuous*, and pursues that design with a steady unaffected ardour, without reserve or falsehood, it is a true sign of a noble spirit: for that love of praise can never be criminal, that excites and enables a man to do a great deal more good than he could do without it. And, perhaps, there never was a fine genius, or a noble spirit, that rose above the common level, and distinguished itself by high attainments in what is truly excellent, but was secretly, and perhaps insensibly prompted by the impulse of this passion.

“But, on the contrary, if a man’s views centre *only in the applause of others, whether it be deserved or not; if he pants after popularity and fame, not regarding how he comes by it; if his passion for praise urge him to stretch himself beyond the line of his capacity, and to attempt things to which he is unequal; to condescend to mean arts and low dissimulation for the sake of a name: and in a sinister, indirect way, sue hard for a little incense, not caring from whom he receives it; his ambition then becomes vanity.* And if it excite a man to wicked attempts, make him willing to sacrifice the esteem of all wise and good men to the acclamations of a mob; to overleap the bounds of decency and truth, and break through the obligations of honour and virtue, it is then not only vanity, but vice.

“To correct the irregularity and extravagance of this passion, let us but reflect how airy and unsubstantial a pleasure the highest gratifications of it afford; how many cruel mortifications it exposes us to.”

“There is,” says another writer, “no greater act of injustice, none more detrimental to society, than to withhold or withdraw the meed of *renown* from the *real benefactors* of our race.

“A desire to possess the esteem and gratitude of our fellow creatures, though not the highest, is yet one of the most legitimate motives of meritorious exertions; one which should never be wantonly repressed by giving currency to either contemporary or posthumous calumny against a useful citizen.”

These sentiments are, in our opinion, so just and at the same time so well expressed, that the intelligent reader will at once perceive their applicability to those subjects which we have just been con-

sidering ; and no apology will be required for inserting them in this place.

Fig. 173, represents a front elevation of a power loom, showing a novel method of working the headles, as well as of throwing the shuttle;\* and Fig. 174, is a view of the crank or driving shaft detached from the loom.

The nature of this improvement consists, in constructing the crank or driving shaft with a cylindrical cam on one end of it, as shown to the left in both Figs., a groove being made round the periphery of this cam, by means of which, in connexion with an intervening lever and straps, the headles are worked ; and also another lever of similar form receives its motion in the same way, for the purpose of throwing the shuttle. The latter of these levers communicates motion to the picker staff, by means of a connecting rod, at its lower extremity, as shown in Fig. 174.

Fig. 173



Fig. 174.

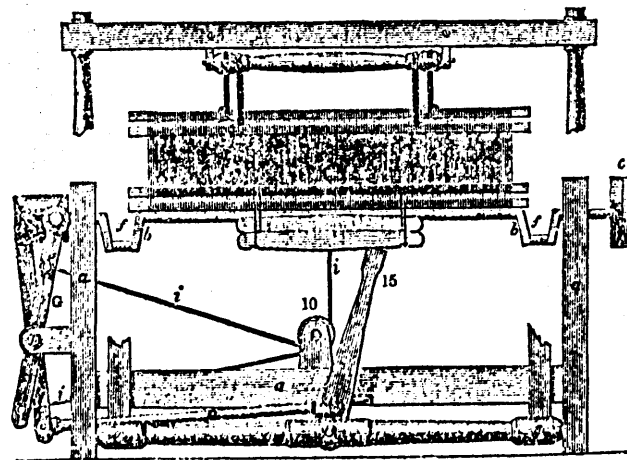

*a a*, is the frame of the loom ; *b b*, the crank shaft, carrying the fast and loose pulleys *c*, on one end, outside the frame, and on the

\* A patent for this improvement, was granted, in the United States, to Frederick Downing, bearing date 27th Jan. 1843.

opposite end, the cylindrical cam *d*, having two spiral grooves *ee*, crossing each other; and *ff*, cranks of the shaft *bb*. In the groove of the cylinder cam *d*, two slides are fitted on opposite sides; the one on the front side is attached to the lever *G*, which has its fulcrum on the shaft *h*, and turns freely thereon; near each end of the lever *G*, a slot is made, in which stud-pins *gg*, are so fastened as to be adjustable (by proper screws and nuts :) to these studs are affixed the straps *ii*, which extend from thence under two pulleys 10, and up to the headles; one strap being attached to each headle.

It will be perceived, that by this arrangement, the headles will be worked as the lever *G*, is vibrated, by means of the button or slide at its upper end, working in the groove *ee*, made on the circumference of the cylinder *d*. The slide or button in the groove *e*, on the opposite side of the cylinder, is connected so as to be adjustable to the upper end of the lever *k*; which lever also has its fulcrum on the shaft *h*: this shaft is on the outside of the loom frame, parallel with its side, and below the cylinder *d*, at right angles to the crank shaft; all of which will be easily understood on examining Fig. 173. The lever *k*, is connected to the picker staff 15, by means of the rod *p*: this rod has its fulcrum at *o*, at the under end of the lever *k*. The fulcrum of the picker staff 15, is at the centre of the lay rocker *q*; the top being connected with the pickers in the usual way. By this combination, it will be perceived that as the cylinder cam *d*, on the end of the driving or crank shaft *bb*, revolves, and vibrates the lever *k*, from right to left, and vice versa, the shuttle will be thrown.

The dispensing with cams and treadles is certainly an advantage: but, this was effected by Mr. Stanfield, of Leeds, as far back as the year 1835. Messrs. Sharrocks and Birch, loom makers, of Great Ancoates street, Manchester, had the construction of Mr. Stanfield's machine; but it appears that they did not succeed in prevailing on manufacturers to adopt it; and, we believe that Mr. Downing's modification of Stanfield's loom will never come into very general use either, for the following reasons:—

- 1st. It is only applicable where two leaves of headles are employed;
- 2d. It is only applicable for weaving light textures, where but little power is required;
- 3d. The rapid motion of the crank shaft *bb*, will soon wear out the small slides or buttons which work in the grooves *ee*, of the cylinder *d*, and this would be found a great evil in a large weaving

room containing some 500 or 600 looms ; but in a small concern, it would not, perhaps, be much felt ; and although the slides or buttons were made of steel, we think this defect would not be remedied ; for, if the slides were of harder metal than that of the cylindrical cam *d*, the grooves of this cam would be worn out first, instead of the slides : in either case a *clitter-clatter* would be the consequence ; and

4th. For heavy textures (plain) the strain would be too great on the cam *d*, as well as on the bearing of the shaft *b b* ; but the motion for throwing the shuttle might possibly be found applicable ; although, we think, with disadvantage as Mr. D. has got it ; for in the working of the headles, as well as in throwing the shuttle, the whole of the strain comes on the small slides or buttons which work in the grooves *e e*, of the cylinder cam *d*.

The patentee informs us, that, he fixes a disc on the shaft *h*, near the lever *k* ; from the face of which disc, two gauges project, one on each side of the lever *k* : these gauges have set screws in them to regulate the distance the shaft shall be turned round by the vibration of the lever *k*. This disc is omitted in the Figs., for the simple reason that, it will not effect what the patentee tells us, as neither a quicker nor a slower motion can be given to the lever *k*, than that which it receives from the grooves *e e*, of the cylinder cam *d*.

Figs. 175, 176 and 176 $\frac{1}{2}$ , represent an improved satinett loom, as constructed by Elijah Fairman, of Stafford, Connecticut ; and for which he obtained a patent in the United States ; bearing date the 6th of February, 1838. The subject of Mr. F's. patent is in the application of an additional cam, or cam, to the horizontal treadles or levers shown in Fig. 176 ; which levers it will be seen have their cam shoes in opposite directions, the top set of shoes to the left and the bottom set to the right. Mr. F. also claims the application of the additional set of cords or strings connected to the under extremities of these upright treadles or levers ; which cords or strings pass under a set of pulleys to the left, as shown in Fig. 176, and are then connected to the headles underneath.

The treadles lie horizontally, one set near the bottom of the loom, and the other set near the top. Each set of treadles is supported at their outer end by two short arms or bars, projecting from one of the back corner posts of the loom ; between which the ends of the treadles are placed one upon another, and a pin or bolt *3, 3*, passes through them and the supporting arms. The other ends of the

Fig. 175.

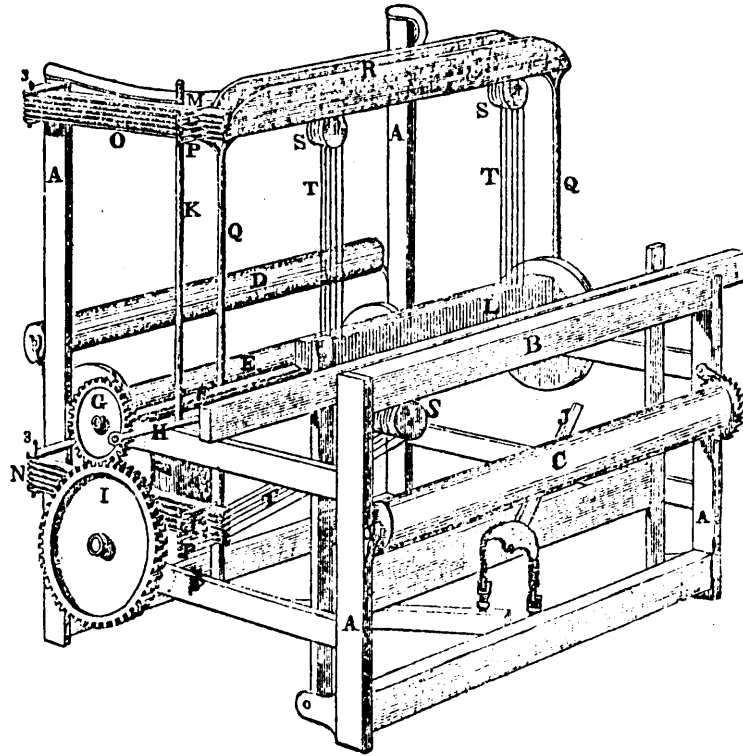

treadles are supported by short thin pieces of iron or wood, fastened to short posts or studs in the frame, projecting out horizontally, one underneath each treadle, forming rests and slides for the treadles to play upon. Each treadle has an iron shoe fastened to its front edge, of a triangular form, on which the cam acts to give the treadles motion. To the end of each of the upper treadles are attached two cords, one of which passes over one pulley, and the other over another pulley, suspended between two headle rails at the top of the loom, and passing down, are fastened to the headles, one near each end.

To the end of each of the under treadles, is attached one cord, which passes under a pulley in the lower part of the loom, and coming up, is fastened to the under side of the same headle in the centre. These cords hold the headle firm that it cannot move up or down, till moved by the treadle; and when one part of the headles is raised, the others are held down, so that the warp opens to let the

Fig. 176.

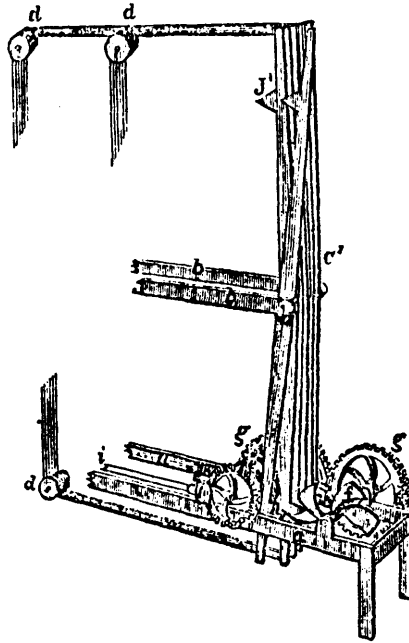

shuttle pass freely. The cams by which the treadles are worked are placed near the top and bottom of an upright shaft, so as to match with the shoes of the treadles, and are so arranged that when an upper cam strikes the shoe of one of the treadles to raise a headle, the corresponding treadle in the lower set attached to the same headle, gives way to the motion, by its shoe being drawn into an appropriate space in the cylinder cam; and when the upper cam has passed the shoe of the treadle, the treadle is drawn back to its place again, by the shoe of the under treadle being thrown out of its space, and pulling upon the headle cord. By these alternate movements of the treadles, by the aid of an additional cam, the action is made free and easy, and the headles kept closely confined to their places, and made to open wider and more clear, that the shuttle may pass without danger of over-shots.

The cam shaft is turned by means of a bevel gear on the bottom of the cylinder cam, driven by a pinion on the cam shaft (see Fig. 176 $\frac{1}{2}$ .)

Another method of producing the same motions and effecting the same object, is to have but one set of long double treadles, standing upright, extending from top to bottom of the loom, and turning upon a pin in the centre, which passes through them, and a short

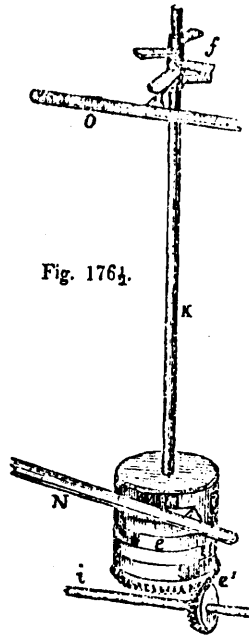

Fig. 176 1/2.

arm or bar on each side, firmly attached to the loom, to support the treadles, as in Fig. 176.

The cams, such as already described, are placed horizontally between two bars or arms attached to the frame of the loom at one end, and at the other supported by a post or posts, standing upon the floor. The lower ends of the treadles have a shoe on each side, exactly opposite, and stand directly between the cams. The cams are carried by a bevel gear and pinion similar to those by which the horizontal treadles are moved; the pinion being placed upon the end of the cam shaft. By the action of the cams on each side of the treadles, they are thrown alternately one way and the other, giving the same motion to their upper ends, but in a contrary direction.

But as this loom is nearly the same as those in common use, it is not necessary to describe more particularly its parts; reference to the Figs. will suffice:

- |   |  |
|---|--|
| Fig. 175, Perspective view of the loom.   | F, Yarn beam, with heads.                              |
| A A A A, The 4 corner posts of the frame. | F, Driving shaft.                                      |
| B, Breast beam.                           | G, Driving wheel.                                      |
| C, Cloth roller, with ratchet wheel, &c.  | H, Lay arm, connecting the lay with the crank wheel G. |
| D, Back whip roller.                      | I, Cam shaft wheel.                                    |
|   | J, The picker staff.                                   |

- K, Cam shaft.  
 L, Headles.  
 M, Separate cams by which the upper treadles are worked, one to each treadle.  
 N, Lower treadles. } Each treadle has an iron shoe on which the cam acts. (See Fig. 176 $\frac{1}{2}$ .)  
 O, Upper treadles. }  
 P P, Bars to separate and support the ends of the treadles, and on which the treadles slide.  
 Q Q, Posts to support the headle rails, &c.  
 R, Headle rails, between which the headle pulleys are hung.  
 S S S, Headle pulleys.  
 T T T, Headle cords. From each upper treadle pass two cords, one over each of the top pulleys, and fastened to the headles near each end. From each bottom treadle, one cord, passing under the under pulley and fastened to the centre of the bottom of the headles.  
 Fig. 176, Represents the upright double treadles, and the mode of operation.  
*a a*, Two arms or bars, attached to the frame of the loom; either to the cross girt or otherwise, as judged best, and supported by a post or posts, standing upon the floor.  
*b b*, Two arms attached to the frame,
- between which the treadles are placed and are supported, and turn upon a pin passing through them and the arms.  
 C, The treadles.  
*d d d*, The headle cords and pulleys over which they pass.  
*e*, The cylinder cam, and *e'*, bevel gear and pinion, as in Fig. 176 $\frac{1}{2}$ .  
*f*, Upper, or 6 part cam, as in Fig. 176 $\frac{1}{2}$ .  
*g g*, Two match wheels on the outer ends of the cam shafts.  
*h*, Shoes on each side of the treadle.  
*i*, End of the cam shaft.  
 J, Shoe on the upper end of the treadle. Shows that the same operation may be had by placing one of the cams at the top, and on the same side as the one at bottom.  
 Fig. 176 $\frac{1}{2}$ , Represents the cylinder cam at the bottom of the headle cam shaft, with the bevel gear, and the pinion on the cam shaft; and the grooves on the cam into which the shoes of the treadle fall alternately, or are driven in as the corresponding treadle is thrown out to raise the headles. It also shows the form of the cams on the upper end of the shaft, and one of the treadles as operated upon by a cam; the cam is on its end a  $\frac{1}{2}$  part of a circle, and the 6 are cast in one piece, one cam above another to match the treadles.

The connexion by cords from the bottom of the headles to the ends of a series of horizontal or vertical levers *is not new*.

The vertical levers having shoes at each end, on opposite sides as shown in Fig. 176, with their mode of operation, will, no doubt answer for looms where a few leaves of headles only are necessary; but in looms for weaving fancy textures, where from 10 to 100 leaves are required, Mr. F's. plan would be utterly impracticable. In such looms, in order to comprise as many leaves as possible in a small compass, they are made of different depths, and their respective shafts are arranged one tier above another, to a sufficient height to prevent them from touching when the sheds are opened. Thus for example, were a mounting to consist of 90 leaves, which is not uncommon for some of the finer kinds of silk patterns woven in Spitalfields, and were the shafts made about  $\frac{1}{8}$ th of an inch thick the whole, by arranging them in three tiers of thirty shafts each might be comprised in about the space of 5 inches. In such cases



neither the vertical treadles or levers, shown in Fig. 176, nor the horizontal treadles, represented in Figs. 175 and 176½, would answer at all, owing to the space they would occupy; for it would be necessary to make them sufficiently thick to bear the strain required for opening the various sheds. European weavers always use sinking cords attached to suitable levers, in connexion with raising cords, and, indeed, they cannot do otherwise in the manufacture of various kinds of tweeled and fancy goods. For further illustration of this subject, see Section Second.

An invention for stopping the loom when the weft thread breaks, was made the subject of a patent by O. M. Stillman, of Stonington, Conn., in November 1841. This improvement consists in making the loom stop of itself when the weft thread breaks or becomes exhausted, by the aid of a contrivance fixed on the breast beam near its centre and directly in front of the lay. The loom represented in the Figs. is of the usual form, showing the stop-thread motion attached: the same letters of reference indicate similar parts in the Figs.

This contrivance consists of a small iron plate *e*, Fig. 177, on the upper side of the breast beam, under the cloth; on the under side of the plate *e*, is placed a slide *s*, the part under the plate being in the form of a staple, and extending back to the square hole in the plate, so as to come against the pin *b*, which stands up in the hook *a*; the other end being a small bar with a series of pins or teeth.

A piece of iron *B*, Fig. 178, is placed on the under side of the breast beam below the plate *e*, and is supported by a bolt passing through it into the breast beam, but left sufficiently loose on the bolt to allow of vibration.\*

The hook *a*, is attached to the inner end of the piece *B*, by a pin on which it works easy, so that the hook *a*, may rise and fall. The pin *b*, is made fast in the hook piece *a*, as shown in Fig. 178, and stands up near the breast beam, passing through the hole in the plate *e*, as represented in Figs. 178 and 179. A small spring *v*, fastened on the front of the breast beam, presses the pin *b*, forward against the slide *s*, which carries the small pins or teeth. A piece of steel *d*, is riveted to the side of the iron *B*, making a right angle with it, and set so as to lap on the end of the shipper *k*, which is hung on the under side of the breast beam, and extends a little be-

---

\* It would be difficult to apply this motion of Mr. Stillman's to looms where a roller was used instead of a breast beam.

Fig. 177, 178 and 179.

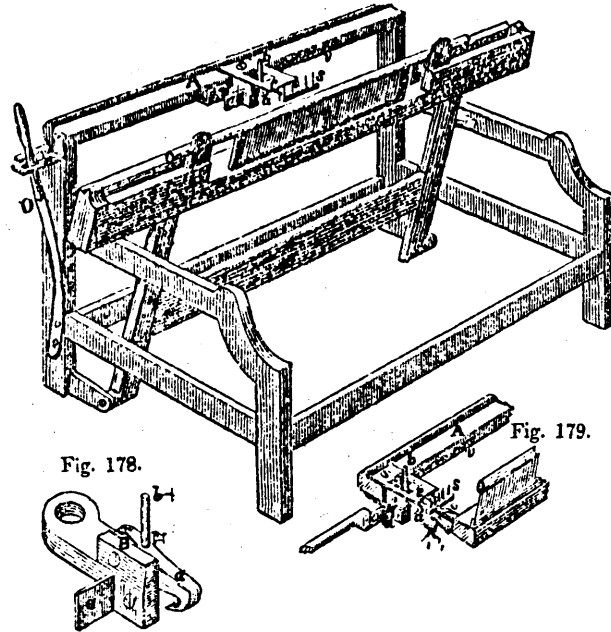

yond the vertical lever *o*. This lever *o*, is of the ordinary description; and it is by it, through the agency of the protecting pin *p*, Fig. 179, striking against the point *k*, of the horizontal lever underneath the breast beam that the belt is shifted from the tight pulley on to the loose one.

When a thread of weft is thrown through the shed, *the reed brings it up against the teeth of the slide s; which teeth are also brought up to the cloth, the inner end of the slide s, forcing the pin b, back towards the breast beam, bending the spring v, and raising the hook a, (Fig. 179) passes under it without collision.\* The teeth, being thus woven into the cloth, are held by the thread until the lay is carried back and the headles change position by springing open a new shed, the action of which operation raises the cloth sufficiently to set the pins free, when the spring v jerks them forward in the warp, ready to receive another weft thread.*

---

\* *The weft thread must be strong enough to enable the slide s, to overcome the elasticity of the spring v. This we consider to be a very serious defect; because the contrivance could not be used with certainty on looms for weaving fine or delicate textures on that very account, even if it had no other fault.*

When there is no weft thread to hold the teeth, they follow the reed as it moves forward, thereby letting down the hook *a*, in time to come in contact with the permanent oblique hook *c*, (Fig. 179) against which it slides, forcing the piece *B*, sidewise, turning on its bolt, which brings the steel piece *d*, against the lever *k*, driving it back sufficiently to cause the other extremity behind the vertical lever *o*, to stop the loom, as in case of the protecting pin *p*, (Fig. 179) striking it in the ordinary way. The motion of the steel piece *d*, being circular, it slides on the lever *k*, a little as it takes it back, which brings the steel piece *d*, before the protecting pin *p*, and stops the lay should its momentum carry it far enough after the belt is thrown off the tight, on to the loose pulley.

This contrivance might be added, with considerable advantage, to looms for weaving wide textures, where the speed is only 38 or 40 picks of weft per minute; but for looms of much greater velocity, it would not answer at all; and this will be evident enough when we consider the mode in which the slide piece *s*, carrying the pins or teeth, is acted upon by the weft thread and reed. Indeed, the very rapid motion of some looms would soon injure that part of the reed which came in contact with the pins in the slide piece *s*. We think that the action of the needles or pins in the slide *s*, in entering between the threads of warp, would be very uncertain, or *hap-hazard*. The needles or pins should not be made sharp at their points, as they would be very apt to *split* any warp threads with which they came in contact in their ascent; neither should they be too blunt, as they would break the threads. This motion is not applicable to looms for weaving figured goods, nor to those where the cloth does not spring or become elevated during the process of forming the shed; *because the pins could not disengage themselves from the cloth* in such looms. These obstacles, with many others which we could mention, will prevent Mr. Stillman's motion from becoming of any great practical utility.

Mr. William Thomas Shallcross, of Holt Town, near Manchester, obtained a patent in January, 1833, for improvements in power looms. The first part of the improvement consists, in driving the shuttle with greater rapidity, and the second, in a new mode of working the headles and taking up the cloth.

The patentee considers, that the construction of a power loom being well understood, it is not necessary for him to describe one, but only to point out those variations in parts of the mechanism which he claims as improvements. The contrivance by which the first object is to be effected, is represented in his drawings in perspec-

tive upon a very small scale, and it is so indifferently described that we can only understand, that, there is a pinion which takes into the crank wheel, and that to a pin in this wheel a connecting rod is attached, which is also attached to a double crank. Then follows a series of other wheels, rods and cranks (which we have in vain attempted to link together,) and ultimately the movements thus obtained, drive the picker staff and causes the shuttle to rush through the shed with the utmost desperation. Several variations of the arrangement of mechanism, accompany the specification, but all are equally obscure: the patentee says, that by these means he renders a loom "*less complicated than heretofore,*" and that by it "labour and materials are economized," and that "the power for driving the loom will be greatly diminished;" all of which, if true, we regret we have not been able to discover. The other features are rendered equally unintelligible, by the smallness of the figures, the obscurity of the description, and the absence of letters of reference in many parts. The inventor does not claim the framing of the loom; which in our opinion is a very great oversight on his part.

Thomas Welch, of Manchester, cotton spinner, obtained a patent in October, 1833, for a method of producing a *varied degree of speed in taking up the cloth*. By the usual method, as the cloth is wound round the cloth roller every additional fold increases its diameter; so that each succeeding fold is wound on with a greater degree of speed than the one preceding it, whereby the texture of the cloth is impaired, and the number of picks to an inch is lessened. The following is the mode of applying Mr. Welch's invention to a power loom:—

A block of wood is provided, which the patentee calls a *saddle*, the face of which is hollowed out, so as partially to clasp the cloth roller, and the greatest diameter of cloth to be rolled on at one time before cutting it out of the loom. This saddle is connected, by a joint pin, with the short side arm of an upright crank lever, affixed to the framing of the loom; from the centre of this lever, a long front arm protrudes, having a forked end which guides an endless strap or band that passes over two conical drums (like that marked S, in Figs. 5 and 6, Plate III) one of which is on the tappet shaft of the loom, its broadest end being nearest the centre of the shaft; the other drum is on a counter shaft, near the cloth roller, its end being farthest from the centre of the shaft. Motion is communicated to this drum from the drum on the tappet shaft by means of the endless band just mentioned.

The outer end of the counter shaft is provided with a pinion,

which drives a series of wheels and pinions;—these communicate motion to a wheel, fastened on the end of the cloth roller, which is thus caused to revolve. One of the wheels, and one of the pinions are provided with a catch box, to which is attached a spring lever by which they may be thrown in or out of gear as occasion requires.

At every succeeding fold of cloth added to the roller it will gradually push the short side arm of the crank lever back, by pressing against the saddle; by this means, the lever will be turned partly round, and its long arm will cause the endless band to traverse towards the pointed end of the drum on the counter shaft, by which means the last mentioned drum will be caused to revolve more slowly; therefore, slower motion will be communicated to the cloth roller, by the wheels and pinions, but the cloth (says the patentee) will be wound on with the same degree of speed as at first, owing to the increased diameter of the cloth beam.

In order to insure steadiness of action, when applying this invention to the taking-up of the cloth, having a large number of picks to the inch, the patentee adopts the following arrangement of parts:

From the back of the saddle, a flat bar of iron extends, and is formed into a rack;—this bar travels in an eye, attached to the centre of a bar, one end of which is fastened to the breast beam of the loom, and the other end extends out, and forms a support for an upright axle. To the upper part of this axle, is fastened a small spur wheel, which is worked by the rack before mentioned; and to the lower part of this axle, is fastened a large spur wheel, which works a rack, provided with a pair of prongs;—these prongs act on the endless bands.

The saddle is kept in contact with the cloth roller, by means of a spring, and the other parts remain the same as before; the motion of the cloth roller being varied by the traversing of the endless bands. The following is the mode of applying this contrivance to a hand loom:—

The saddle, upright crank lever, and its arms, as well as the pinions and wheels which turn the cloth roller, are the same as in the first instance, with the exception of the catch box and spring lever, which are removed for the reason hereafter explained.

The drum, which was before on the tappet shaft, is now fastened on a crank shaft, having two cranks, and is steadied in its revolutions by a fly wheel, at one or both ends. This shaft is turned by two crank arms, extending from the lay to the crank, and it communicates motion, by means of an endless band (and two stout

Irishmen) to the other drum, which is fastened on a counter shaft, the endless band being caused to traverse by the long arm of the lever, in the manner above described.

The patentee says, in concluding his specification, that "when the lay ceases its vibrations the whole must stop; therefore, the catch box and spring lever, for throwing the wheels and pinions out of gear, in order to stop the cloth roller, are useless;" to which we respond, yaw! yaw!! yaw!!! That the machinery of a common power loom should continue its regular evolutions after the lay ceases to vibrate, is, indeed a mysterious affair; and is well worthy the attention of the learned. The looms represented at Figs. 161, 162, 163 and 164 will accomplish the object of this patent with much greater precision and simplicity; to which Figs. the reader is referred.

The cone drums, applied to looms for taking up the cloth in the way claimed by Mr. Welch, is an old German idea, and is not worth a stiver.

Thomas Mellowdew, of Walshaw Cottage, Oldham, Lancaster, mechanic, obtained a patent in May, 1838, for improvements in looms; which improvements consist in certain machinery to be attached to looms for weaving various kinds of cloth; and *set in motion by the pull, strain, or jerk given to the warp threads by the blow of the reed in beating up the weft*; and which produces by its action a regular, corresponding, and sufficient delivery from the warp-beam, and taking up of the cloth on the cloth-roller so long as there is weft-thread added; but which delivery and taking up cease, in case of the breaking or non-delivery of the weft, or *shortly afterwards*, in consequence of the reed on being at such times struck up, meeting with a *diminished* resistance, inadequate to cause a sufficient pull, strain, or jerk upon the warp threads, to produce the effect required, although the general evolutions of the loom continue.

We need not here recapitulate the immense long yarn given by the patentee, as explanatory of his invention, as all that it effects may be accomplished by the loom represented in Fig. 171, by that shown at Figs. 165, 166, 167 and 168, or by that at Fig. 169; either of which looms is far superior (both as regards working and simplicity of construction) to Mr. Mellowdew's, as any manufacturer pretending to a knowledge of such subjects will at once perceive. In summing up his specification, Mr. Mellowdew says, "what I claim as my invention, is the causing the pull or strain upon, or jerk of the warp-threads, occasioned by the blow of the

reed in beating up the weft when sufficient resistance has been presented to it by the supply of the weft from the shuttle to produce, by means of a vibrating carrying roller, (whip-roller) supported on vibrating levers, and acted upon by the jerk of the warp with the other machinery herein described, when attached to looms for weaving various kinds of cloth, a regular corresponding, and sufficient delivery of yarn from the warp-beam, and taking up of cloth on the cloth roller, so long as the proportionate filling up of the weft continues, but which delivery and taking up will cease in case of the breaking or non-delivery of the weft, or *shortly afterwards*, in consequence of the reed, on being struck up, meeting with a diminished and inadequate resistance, and, therefore, causing a diminished pull, strain, or jerk." All this, as we before observed, may be effected with the modification of Mr. Stone's loom, shown at Fig. 171; and which modification was made the subject of a patent in the United States, as formerly stated, 23d November, 1837, about six months prior to the date of Mr. Mellowdew's patent.\*

We might here give accounts of some 50 or 60 other contrivances which have been made the subjects of patents in Great Britain, France, Belgium and America, for several years past, for governing the delivery of the warp and the taking up of the cloth in common power looms; but none of which contrivances are at all equal in point of practical utility or simplicity to those shown at Figs. 165, 166, 167, 168, 169, 170 and 171. For weaving delicate textures, such as gauze, light silk stuffs, &c. positive take up motions (in connexion with a motion to stop the loom when the weft thread breaks or becomes expended on the cop or bobbin) must be used instead of the vibrating reed; we shall, therefore, close this part of our subject by referring the reader to Section Twelfth.

---

\* Whenever a patentee intends fraud or concealment, he finds it most easily accomplished by drawing out a long and intricate specification; describing in a manner as minute and circumlocutory as possible hundreds of well-known parts, and summing up his claims in so ambiguous a manner as to defy all the powers of human penetration to discover their meaning. Such *scare-crow* specifications afford to the designing an ample pretence, and an effectual cover for private injustice and professional rapacity. We could name instances were we disposed to be personal.

## SECTION ELEVENTH.

## FANCY WEAVING.

“ The wise and prudent conquer difficulties  
By daring to attempt them. Sloth and folly  
Shiver and shrink at sight of toil and danger  
And make the impossibility they fear.”—HOWE.

By the term *fancy weaving* we mean the weaving of those small patterns which are produced in looms mounted with leaves of headles ; and of which we have already given sufficient explanation in Sections Second and Third.

For a complete description of the method of weaving figured patterns of *unlimited extent, by power*, see next Section. In the present section we shall confine our remarks to those looms for weaving fancy textures which we consider to be of most practical utility, with such other information as has a direct bearing on the subject ; and, in the outset, it may, perhaps, not be amiss to offer a few observations on fancy textures in general.

The smaller mountings, with leaves of headles, produce but a very limited variety of patterns, commonly a small diamond or lozenge figure, with a dot or speck in the centre, which gives it the resemblance of an eye : hence these figures are generally denominated bird-eye patterns. When the mountings, however, extend to eight leaves and upwards, they admit of considerable diversity in flushing, tweeling, and plain texture, deviating from the formal figures of the bird-eye, and which now assume the appearance of what is called lined work.

The draught of lined work patterns may be considerably diversified by dividing the leaves into two equal portions, and drawing a few sets of the diamond draught on each portion, alternately. This arrangement throws the group of small figures produced by each set of leaves, into alternate squares, somewhat resembling the dam-board pattern, shown at Fig. 36, Section Second. It is customary, however, to introduce an odd leaf into these mountings, immediately between the divisions, which serves as a point leaf to both sets.

Any number of concentric figures may be formed, by repeating



the draught several times over the leaves in one direction, and returning in the contrary direction as often so that should the draught diverge from the centre of the cloth toward each selvage, and the treading continue to the same extent, the pattern would be one great figure, composed of concentric squares, whose dimensions and variety would depend on the number of leaves, and the arrangement of the raising cords.

*Tweeled and plain textures.*—For patterns of this kind, the mountings will consist of one set of plain, and one set of tweeling leaves, and the raising and sinking cords of the plain mounting are tied alternately on the tweeling treadles. It must be observed, however, that in all mountings which have an odd number of tweeling leaves, double the number of treadles are requisite, in order to make the plain sheds alternate without interruption.

All tweeled stripes, which have an even number of tweeling leaves, are woven with one set of tweeling treadles, as the sheds of the plain parts can then be made alternate without any interruption.

Where the pattern will permit, the greater portion of the tweeling leaves should be sunk, and therefore, the weft will appear to most advantage on the upper side of the cloth while in the loom. Besides this advantage, the strain on the machinery will not be near so great, in raising the smaller portion of leaves.

Sometimes the draught of a tweeled stripe is made in the diamond form, and the pattern produced is commonly called a dart stripe, or herring bone.

When a web is to be tweeled across, in order to form checks or the borders of handkerchiefs, the same number of leaves must be employed for the ground that are requisite for the tweeled stripe. Thus, to convert a four leafed tweel stripe into a check, the common mounting of four leaves, will produce a similar tweel across the web. But should the stripe be woven in a six or eight leafed tweel mounting, the plain parts must also be drawn on six or eight leaves, and each leaf is corded so as to rise and sink alternately in the plain parts, but to produce the tweel in the check. Hence it will appear, that a stripe with an odd number of tweeling leaves will not admit of a similar tweel for the crossing or check, as the ground leaves must always be divided into equal portions in weaving the plain parts.

Any tweel of an even number of leaves may be converted into stripes and checks; and if the stripe be formed into a dart or herring bone, the plain may be woven by a single over and over

draught, and converted into a check the same as the stripe, by working over the treadles in one direction for half of the cross stripe, and reversing the order of treading for the other.

Gauze, veining, purles, spidering, &c. are also variously combined with several of the other branches of fancy weaving, and produce some of the most beautiful and delicate patterns in the *silk* and *cotton* manufactures. To obtain a knowledge of gauze, veining, spidering, &c. the reader must consult Section Fourth.

It must be observed, however, that when gauze and plain are woven in alternate stripes, those parts of the reed which are occupied by the plains will be full; but in the gauze spaces, a dentful of the warp passes through every second interval only; consequently, the set of reed in the former, will, in general, be double of that in the latter. And hence, when additional weft is thrown in, the plain texture will make a pretty bold contrast to the light transparent fabric of the gauze.

As the warp of gauze, when converted into plain texture, produces but a very thin or flimsy fabric, it is necessary to introduce additional warp as well as weft into those parts which are woven plain, which, one being flushed above, and the other below, the gauze spaces, are afterwards cut away. A dentful of this additional warp is taken into the reed alternately with a dentful of the gauze; so that the former, as noticed above, is exactly double the set of the latter.

This method of forming patterns with gauze and cambric, like some of the other branches of fancy weaving, may be extended to all the varieties of a diaper mounting (see Dornic and Diaper, page 112, Section Second :) for any draught of the latter may be adapted to the former, merely by substituting one set of gauze, and one of plain leaves, for each set of the tweel, and varying the succession of the draught and treading accordingly.

It is not customary for the manufacturer to annex the plans of cording to these compound draughts; neither is it always necessary, particularly in extensive business, to represent in the draught every leaf which is requisite in the mounting. All that is commonly required in the draught is, to point out to the headle-maker, the quantity and arrangement of each kind of the warp in one set of the pattern, with the number of times the pattern is to be repeated; and to the weaver, the order of succession in which these several warps are to be drawn into their respective mountings; each being supposed to understand his own department of the business.

The first loom to which we shall turn our attention in this Sec-

tion, is the invention of Mr. Charles Fletcher, an ingenious mechanic, of Stroud, county of Gloucester; and for which he obtained a patent in March, 1838. This loom, being of vertical construction, differs very much from those described in Section Tenth; and although it is not, in some respects, calculated for weaving fancy textures, we think it may, without impropriety, be explained in the present section.

The invention consists, firstly, in a peculiar arrangement or disposition of mechanism, for the purpose of weaving *woollen goods*; and secondly, in the introduction of certain new parts or pieces of mechanism into looms in general, by means of which considerable advantage, as to speed and uniformity of work, is obtained, especially as regards the weaving of woollen cloths.

By these improvements, Mr. Fletcher assures us he is enabled to weave better cloth by power than has *hitherto been accomplished by hand*, the cloth being *much firmer*, and the mechanism affording the capability of making more "picks" per minute, and causing less breaking of the warp threads, thereby producing a fabric of *better quality, and in greater quantity, in a given time*.

In this loom the yarn beam is situated at the bottom of the framing, and the cloth roller is placed at the top (as in E. K. Arphaxad's great weaving engine, pages 20 to 37, of the Introduction.) The warp threads proceed through the headles in vertical positions, while the headles are moved to and fro horizontally. The lay is made to rise and fall vertically by the action of suitable cams and levers, and is impelled upwards by the momentum of a falling weight, or weights, which can be so regulated and adjusted as to increase or diminish the blow, as may, under circumstances, be found desirable. This part of the mechanism is also furnished with suitable elastic regulating stops for the rising lay to strike against at the moment that the reed is beating up the weft, and by the elasticity of these regulating stops, the sudden concussion of the lay, and consequent strain upon the warp threads, is immediately relieved; whilst the blow being caused by a descending weight mounted upon the end of a lever attached to the cam shaft, any degree of impulse can be given to the lay without causing an undue strain upon the warp threads, and with much greater effect upon the cloth than can be obtained by the *best hand weaving*.

In order to illustrate Mr. Fletcher's improvements in the construction of looms, and that they may be more definitely explained, we have drawn the figures on an enlarged scale, which will enable the reader better to comprehend the novel features of the machine.

Fig. 180.

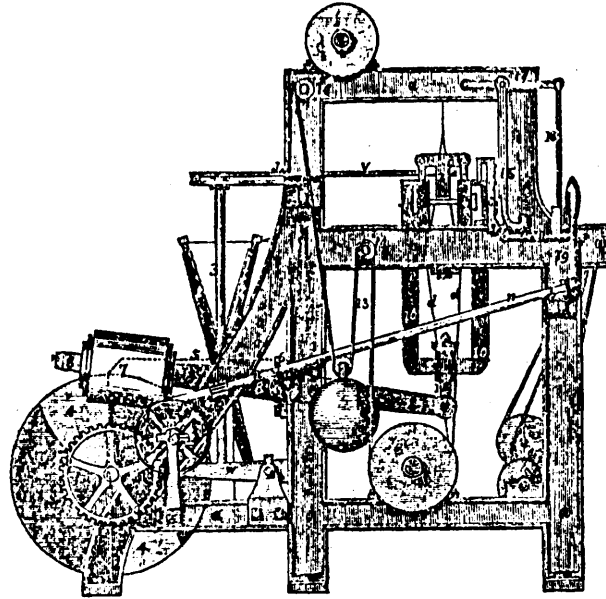

Fig. 180, is a side view of the loom ; Fig. 181, a plan view ; Fig. 182, a back view ; and Fig. 183, a section, taken through the middle of the machine, showing the position of the warp and the apparatus for working the headles.

The side frames, in which the ordinary parts of the loom are mounted, are represented at *a a a*, being connected by traverses or rods *b b*. *c*, is the yarn beam or roller (see Fig. 183) upon which the warp *d d*, is wound. The warp threads proceed from the yarn beam through the headles *e e*, which slide horizontally in bearings *f f*, affixed to the frame *a a*, on each side.

It will be seen that the cloth, as it is produced by the weaving, proceeds over the breast beam *g<sup>2</sup>*, (Fig. 183) to the cloth roller *h*, at the top of the loom.

The shuttle boxes are shown at *i i*, (Figs. 181 and 182) secured fast to the sides of the frame *a a*, and are quite free from, and independent of the lay or reed.

Upon the main driving shaft *k*, the strap pulley *l* (Figs 180, 181 and 182) is thrown into gear with the driving pinion *m*, by means of the setting-on rod *n n* ; and the pinion *m*, being geared with the toothed wheel *o*, which is fast upon the cam shaft *p p*, the toothed wheels *q q* (Figs. 181 and 183) are actuated. The larger of these

Fig. 181.

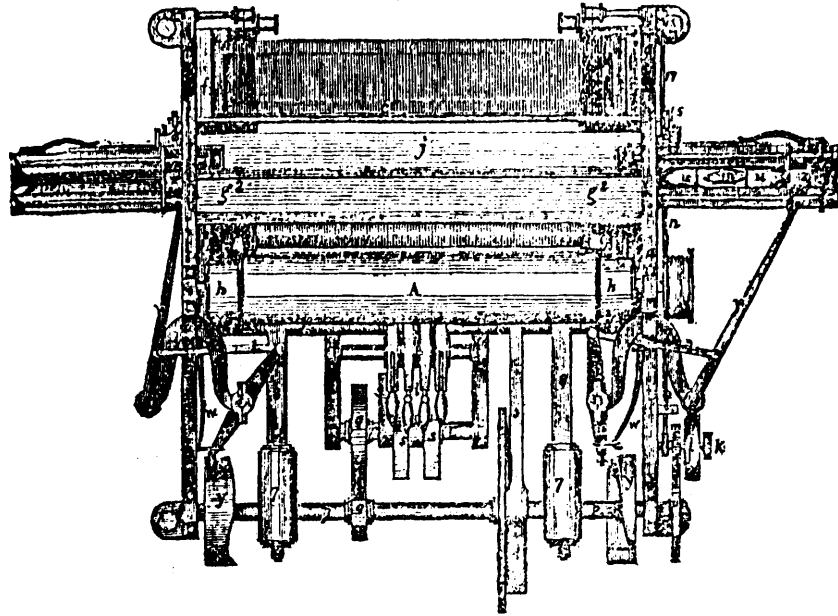

Fig. 182.

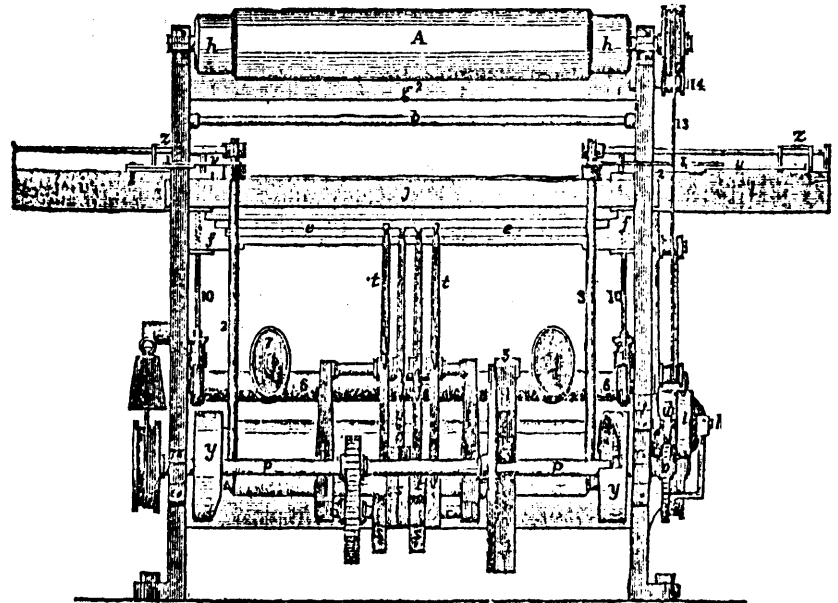
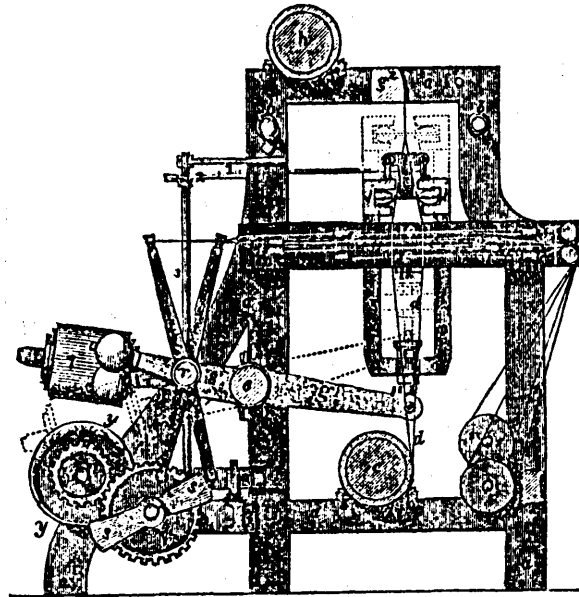

Fig. 183.



wheels  $g$ , is keyed fast upon the tappet shaft  $rr$ , upon which the tappets or cams  $sss$ , are also mounted; thus it will be seen, that as this tappet shaft  $rr$ , revolves, the tappets  $sss$ , will successively actuate the treadle levers  $tt$ , and divide the warp threads by shedding the headles at proper intervals for the passage of the shuttle  $uu$  (Fig. 181.) The shuttle is projected across the loom by means of the picker stick  $v$ , which is suddenly actuated by the spring  $w$ , causing the roller (see Fig. 181) upon the end of the short lever  $x$ , to escape the step or fall cut upon the scroll cam  $y$ , keyed fast upon the cam shaft  $pp$ .

It will be seen that there is one of these scroll cams at each end of the cam shaft, having the step or fall cut in opposite points of their peripheries, in order to effect the projection of the shuttle from each side of the loom alternately, which will be readily understood by persons conversant with the ordinary evolutions of power looms.

The extreme end of the picking stick  $v$ , bears against the sliding piece  $z$ , and exactly at the point opposite the centre line or point of the shuttle, so that the shuttle will thus receive a blow in a direct line through the shed, instead of being liable to that uncertain course sometimes produced when the slide piece  $z$ , is attached to the picking stick by a cord. Near the end of the picking stick is attached a link 1 (see Fig. 181) connected to the lever 2, fast upon

the upper end of the vertical rod 3; which lever 2, is placed in an opposite direction to the lever *x*, fast at the lower end of this rod. By these means the picking stick is suitably actuated by the rotation of the scroll cam *y*: the vertical rod 3, is also visible in Figs. 180 and 182.

The sudden rise of the lay *j*, and the necessary sharp blow which is desirable to beat up the cloth, as each weft thread is put in, is effected by the cams 4, 4, which are fast upon the shaft *p p*, and consequently revolve with it, actuating the lever 5, fast upon the cross shaft 6, and allowing this lever to escape or fall past the straight side of the cam, as will be clearly seen in Fig. 183, where the lever 5, is shown just upon the point of escaping the cam *b*, and is drawn in dotted lines in the same figure as having escaped this point.

By the momentum of the falling weights 7, 7, at the ends of the levers 8, 8, (fast upon the cross shaft 6, as in Fig. 183) the levers *g g*, (also made fast upon the shaft *p p*,) are made to rise, and as the frames 10, 10, carrying the lay *j*, are attached to the extreme ends of these levers *g g*, the lay (see Figs. 181 and 183) will immediately ascend with a sharp quick stroke, and thus perform the beating up of the weft thread.

It will be seen that these frames 10, 10, (as there is one to carry each end of the lay) are provided with adjustable stop pieces or set screws 11, (see Figs. 180 and 183) so that the stroke of the lay or degree of impetus may be varied to suit the kind of texture to be produced. As the lay ascends, all the strain upon the warp threads is obviated by means of the india rubber or other elastic bed 12, (see Figs. 181 and 183) with which each side of the loom is provided, for the purpose of giving a slight rebound to the lay, as the stops 11, strike against the bed 12, and thus preventing any possibility of breaking the warps in consequence of the sharpness of the blow given by the lay. It will also be perceived that the degree of impetus given to the lay may likewise be adjusted by sliding the weights 7, upon the levers 8, 8, as occasion may require.

As the blow of the lay against the weft thread is quite sufficient to cause the yarn beam to give out the quantity of warp required, consequently, the taking-up motion which is usually attached to power looms may be dispensed with, merely keeping the whole in proper tension by means of the friction band or weighted cord 13, conducted over suitable tension pulleys 14, 14, and round the drums at the ends of the warp and cloth rollers (see Fig. 180.)

In case the shuttle should not enter the shuttle box at every stroke of the picking stick, the notched lever 15, will catch upon

the tooth or nib 16, (see Figs. 180 and 181) upon the lay as it rises, and thereby raise the lever 17, and by the agency of the rod 18, lift the hand lever 19, off the pin fixed in the side of the setting-on rod *n n*, which will cause the spring 20, (see Fig. 180) to throw the driving pulley *l*, (see Fig. 181) out of gear with the pinion *m*, and thus the loom will be stopped.

The most curious feature in Mr. Fletcher's loom is, in having the *shuttle boxes detached from the lay, and fixed or made stationary upon the framing of the loom, or outside the loom, so that when the warps are divided, the blow from the picker staff can instantaneously be given to the shuttle, which is at rest, and as such blow may thus be given in a direct line with the points or centre of the shuttle, the shuttle will be impelled through the warps in a straight undeviating line, instead of being liable to that zig-zag course so frequent in common power looms, caused by the direct impetus given to one side of the shuttle, and while it is in a state of constant motion with the vibration of the lay, thus frequently throwing the shuttle out of its direct course, causing it to break through the warps and fly out of the loom.*

This machine is highly creditable to the mechanical skill of the inventor; and although the idea of placing the warp vertically in a power loom did not originate with Mr. Fletcher, yet we think his method of effecting this object is decidedly the most practical for the manufacture of plain textures of any hitherto introduced: it admits, however, of still further improvement, and might, in skillful hands, be turned to good account.

The working of a series of shuttle boxes disconnected from the lay and fixed on the framing of the machine, or outside of it, is *not new*, it having been introduced, from *Persia*, into France, about 15 years ago, by M. Eugene Gigot, an antiquarian, of Mulhausen; and since then various modifications of it have been patented in Great Britain and America. Messrs. John and Arch'd Reid, of Glasgow, adapted the detached shuttle boxes to their *vertical power loom*; for which loom they obtained a patent in 1835. In France, the detached shuttle boxes have received the cognomen of the "squirrel cage." It would appear, from the oration delivered before the Median monarch, King Deioces (see Introduction) that Arphaxad was well acquainted with the principle of the rotary detached shuttle boxes, and those procured, in the East, by M. Gigot are doubtless of the invention of that ancient and ingenious *manufacturer*.

Mr. Fletcher's shuttle motion, shown in Fig. 181, is a very ~~poor~~



erful one; and we think it might be used with advantage on looms for weaving wide textures.

Messrs. John Ramsbottom and Richard Holl, of Todmorden, Lancashire, obtained a patent in July, 1834, for certain improvements in the construction of power looms, by which two pieces of cloth may be produced at once. In their loom, the warp-threads are placed vertically in two ranges, one range extending from a yarn beam below to the cloth roller at top in the front of the loom, and the other range extending similarly at the back of the loom. The patent for this machine was purchased by Messrs. Cousins, Diggle & Co., manufacturers and machinists, Bury, Lancashire, (where we saw the loom,) for the sum of £200, sterling. After a short trial, it was found not to answer the expectations of the purchasers, whereupon they returned it to its original owners. This same company paid us a handsome sum, in the year 1836, for an improvement upon a power loom for weaving muslin, and other light textures; which, we are happy to say has met their most sanguine anticipations: we sold the Scotch and French patents for the same invention to John Chanter, Esq., of Stamford st., Blackfriars, London.

George Clarke, of Manchester, manufacturer, obtained a patent in January, 1840, for improvements in the construction of looms, by means of which patterns of considerable extent may be produced on the cloth. This invention may be said to consist, firstly, in a peculiar arrangement of mechanism, forming an endless and flexible rack of teeth or tappets, to be employed in looms, in place of the ordinary revolving tappet-plates or wheels; and secondly, in the application and use of such apparatus, in combination with certain other arrangements of mechanism.

The variety of patterns is obtained by a greater extent of operations being afforded to such working parts of the loom as are required to shift the headles, for shedding the warps, in order to work or produce the pattern or figure, *without the assistance* of the Jacquard machine.

This mechanism, which may be readily applied to fancy looms, is so constructed, that a great variety of shifts, changes, or "numbers to the round," may be accomplished, before it becomes necessary to repeat the order of shedding or recommencing the same pattern or figure, by renewing the "round" (as it is termed by the weaver) and any required alteration in the figure to be produced, may be made with facility and speed; that is, the "reading on" of the tappets or teeth may be varied to a much greater extent, than can be commonly done by the ordinary tappet wheels.

It should here be remarked, that endless chains or ladders have been heretofore employed, for the purpose of changing or shedding the warps, but they are constructed so as to carry rollers, revolving on certain bars, as their axes, and adjustable, longitudinally in their situation thereon ; which rollers act upon certain vertical levers, and thereby effect the shedding of the warps.

But Mr. Clarke's flexible tappet rack, is formed by simply providing a given number of bars or ribs of a certain length, according to the number of shafts or headles employed in the loom, or the width they occupy, and placing them at certain distances apart. Upon these bars are mounted, in any convenient manner, teeth, tappets, or studs, capable of being readily adjusted, as the different patterns or devices to be woven may require ; the whole are formed into an endless flexible rack or band of tappets, by side bands, belts, or chains, hereafter more particularly detailed.

In order that this invention may be more perfectly understood, two modes of applying the improvements are shown in the figures.

Fig. 184.

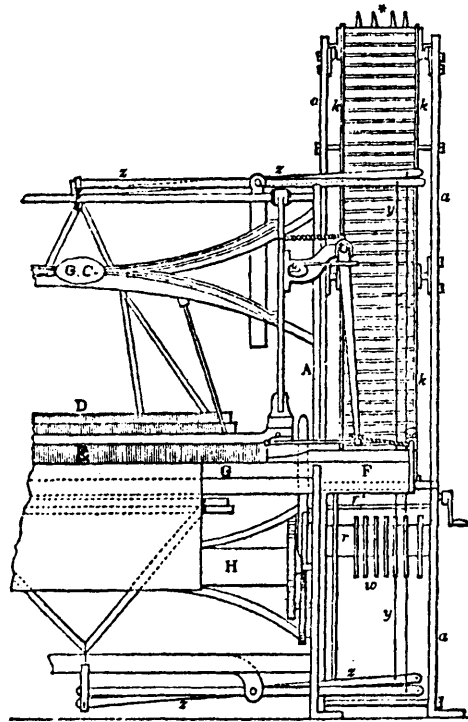
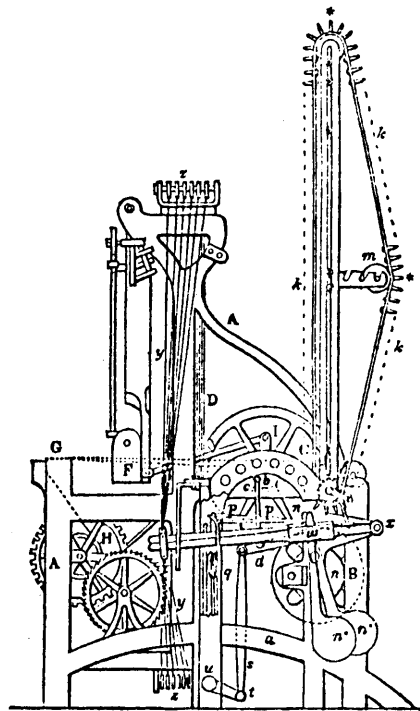

Fig. 184, is a front view of a power loom, representing the application of one description or arrangement of the improved endless belt or chain of tappets to a loom for weaving figured fustians; and Fig. 185, is a side elevation of the same. The ordinary framing or loom-sides, are shown at A A, supporting the warp roller B, from whence the warp threads C, proceed through the headles D, also through the reed E, (see Fig. 184) of the vibrating lay F, (Fig. 185) over the breast beam G, to the cloth roller H, as usual. The ordinary crank shaft of the loom is shown at I, from which motion is communicated to the improved mechanism, attached to the side of the loom, and supported in a separate framing *a a*, as follows:—

Fig. 185.



Upon the end of the crank shaft I, is fixed the crank plate *b*, (see Fig. 185) revolving in the ordinary direction, and actuating the link *c*, (see also Fig. 186) attached at its upper end, by a pin, to the crank plate *b*, and at its lower end to the lever *d*. This lever *d*, vibrates upon its fulcrum at *e*, and carries, at one extremity, a draw catch *f*. This apparatus is seen detached from the loom in Fig.

186, and is designed for the purpose of actuating the catch-wheel *g*, one tooth at every revolution of the crank shaft *b*; the catch-wheel *g*, is mounted upon the shaft *h*, (see Fig. 187) and upon this shaft, the notched guide-wheels *i i*, are also fixed; around and taking into which, the flexible rack or belt of tappets *k k k*, passes (see Fig. 184.) A detached view of the guide-wheels *i i*, catch-wheel *g*, and shaft *h*, is shown at Fig. 187.

Fig. 186.

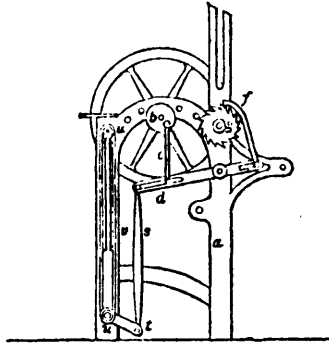
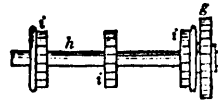

Fig. 187.



The tension pulley *m*, placed about midway in the frame, is for the purpose of assisting the drag or weight of the tappet-rack.

It will now be seen, that as the travelling tappet-rack proceeds, the teeth, studs, or tappets \* \*, of which it is partly composed, (and which it will be evident to the practical weaver, are so placed, arranged, or "read on," according to the pattern or device to be woven,) will strike against the heads of the headle levers *n n*, (see Fig. 185) with one of which, each headle *D*, is in connexion. These levers *n n*, are all suspended, and vibrate upon the shaft or fulcrum *o*, (see Fig. 185) and are each connected by means of links or wires *p p*, to the hooked lifters *q q q*, for the purpose of throwing the lifters into the position, where they may be acted upon by the rising cross-bar *r*.

The requisite action of the rising and falling bars *r, r\**, (see Fig. 184) is effected, simultaneous, with the progressive motion of the tappet-rack *k k*, also by means of the link *o*, vibrating the lever *d*; on the other extremity of which, the connecting lever *s*, is attached, (see Figs. 185 and 186) which is jointed at its lower end, to the crank *t*, fixed upon the roller *u*, around which a strap or belt *v v*, (see Fig. 186) passes, and over a similar roller *u*, at top. To this strap *v*, the bars *r, r\**, are fixed; and it will be seen, that as the

strap traverses, by means of the vibrating action imparted to the crank *b*, on the end of the crank shaft *F*, the requisite alternate raising and depressing of these bars is accomplished; they are kept in parallel positions, by traversing up and down in mortices, in the frame *a a*. The headle levers *n n*, are also brought into the position, where they may be acted upon by the falling bar *r\**, by means of the weight *n\**, with which each lever is furnished (see Fig. 185.)

The hooked lifters *q q*, are each separately connected by a pin to vibrating treadles *w w*, working on their fulcrum shaft *x*, fixed to the frame *a*. These treadles *w w*, are connected at their extremities, by means of the wires *y y*, (see Fig. 184) to the ordinary top and bottom jacks *z z*, and, by the customary stringing, to the headles *D*, and thus, as the tappet-belt or rack revolves, will shed the warp, and consequently work the pattern.

Fig. 188.

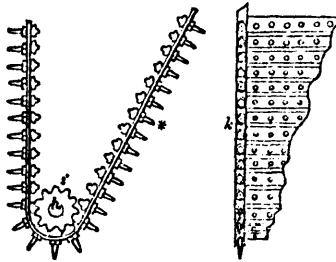

Fig. 189.



Fig. 188, represents a portion of the tappet-rack detached, upon an enlarged scale, and Fig. 189, the several pieces of which the improved endless tappet-rack is composed. 1, shows a front view, and 2, a back view, of the perforated bar, for receiving the studs, teeth, or tappets 2;—3, the nut, by which the tappets are held, and adjustable in the bar. A number of these bars, placed at suitable distances apart, and furnished with the necessary number of holes for “reading on” the tappet-studs, as the pattern requires, are formed into an endless rack, belt, or chain, by being screwed or otherwise fixed upon a band, composed of canvas, tape, and leather, cemented together by means of a solution of caoutchouc.

At Fig. 190, a modification of the improvements, and the mode of applying the same to fancy looms, is shown. The drawing re-

presents a partial sectional view of the figuring apparatus, attached to an ordinary loom side. An endless belt, or rack of teeth, studs, or tappets *a a a*, passes around, and is progressively actuated by the grooved rollers *b b b*, supported in the framing *c c c*, attached to the side of the loom.

Fig. 190.

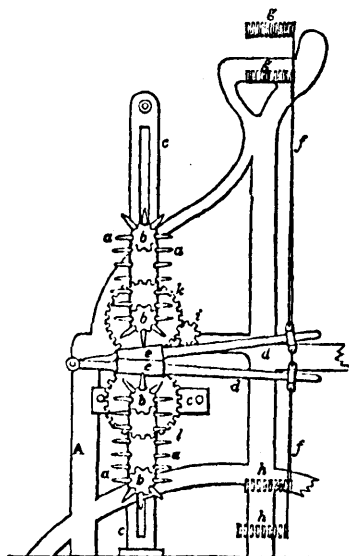
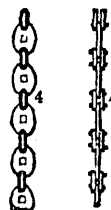

Fig. 191.



The moveable tappets, or teeth *a a a*, are suitably arranged upon their bars or rails, (as in the former instance,) to work the pattern or device required, and are alternately caused to raise or depress the treadsles *d d*, successively, by acting upon the rollers *e e*, with which they are provided. Thus the simple action of these risers and fallers is transmitted directly to the headles, by means of the connecting wire *f f*, actuating the top jacks *g g*, and bottom jacks *h h*, which are connected by stringing to the headles, as usual, the whole being put in motion by means of the spur-pinion *i*, upon the end of the ordinary crank-shaft, driving the spur-wheels *k*, and *l*, upon the axles of the grooved or fluted rollers *b b*.

The bars or rails of tappets are connected together at suitable distances into an endless chain, by being confined or strung together by the chain 4, 4, shown at Fig. 191, at each side, or by any other suitable means; thus it will be seen, that these studs or teeth, and their intervening blanks or spaces, may be so arranged, upon any bar, or system of bars, that the necessary raising and depressing of

the treadles *d d*, may be varied or adjusted, to suit the pattern or device required to be woven; which arrangement, adjustment, or "reading on" of the tappets or teeth, in both the above descriptions of racks, belts, or chains, will be readily understood, and applied by the practical weaver.

This improved loom of Mr. Clarke's, is, no doubt, the best hitherto introduced for weaving fancy goods, and, in our opinion, it is worthy the attention of manufacturers of such textures. Various other contrivances for working a series of headles have been invented, by different individuals, but none of them are equal, in point of practical utility, to Mr. Clarke's. We shall, however, briefly notice a few of those which are likely to prove interesting, for the *benefit* of manufacturers who *live in the country*.

Mr. Robert Bowman, of Manchester, obtained a patent in January, 1821, for improvements on the power loom, enabling him to work six leaves of headles; which headles are suspended by cords from the ends of a set of top levers, and are also attached to another set of levers or treadles underneath. The movement for raising and depressing the headles is obtained by means of two sets of tappet wheels, each set having as many tappets as there are headles. These tappet wheels are fixed, one set above and the other below, and are turned by means of a pinion upon the end of the crank or driving shaft.

Mr. Richard Roberts, of the firm of Sharp, Roberts & Co., Manchester, obtained a patent in November, 1822, for a tappet wheel; but as it does not differ in principle from Mr. Bowman's, it is unnecessary to describe it.

John Potter, Esq., of Smedly, near Manchester, obtained a patent in May, 1825, for an improvement in power looms, for weaving various kinds of fancy goods; which improvement consists, in working a number of headle-leaves by means of two series of levers, attached to the side of the loom, one series at top and the other at bottom; and as these levers rise and fall, the headles are moved up and down, for the purpose of shedding the warp. The apparatus by which the levers are actuated, is similar to the common barrel organ, and does not differ, in any respect, from that used by Mr. Fairman, in his loom, shown at Figs. 175, 176, and 176½; the levers and cords which connect and work the headles at top and bottom are also the same as those employed by Mr. F.

Joseph Jones, of Oldham, Lancaster, cotton manufacturer, and Thomas Mellowdew, of the same place, mechanic, obtained a patent, June 16th, 1834, for improvements in the construction of

power looms, adapted to the manufacture of corded fustians, and which improvements consist, in the adaptation of an endless chain of plates, or links, to the common power loom, so constructed as to govern the position of the headles, according to the kind of cord, or diagonal stripe to be produced on the cloth. The principle of this improvement is the same as that of Mr. Clarke's invention, represented at Figs. 184, 185, 186, 187, 188, 189, 190 and 191; which precludes the necessity of a more detailed description.

Enoch Burt, Oliver D. Boyd, and Amos H. Boyd, of Manchester, Conn., obtained a patent 19th August, 1828, for what they term, "an improvement in the check or plaid power loom;" which improvement consists, firstly, in fixing a wheel, about 8 inches in diameter, to the side of a common power loom, upon the periphery of which wheel, at right angles with its plane, are constructed as many shuttle boxes as there are colours in the check or plaid to be woven. On the backside of this wheel, is a small toothed wheel which is turned forward and backward, by means of two arcs of a circle, or segments of a wheel, on the ends of two levers, moving on a stud as their common fulcrum. One of these arcs or segments is toothed on the outside and the other on the inside, embracing between them the before named small toothed wheel. A power acting in the same direction, alternately on the other end of the said levers causes the shuttle boxes to move forward and backward, bringing each shuttle box, in turn, to a proper position for discharging its shuttle through the shed and receiving it again from a box of the ordinary kind on the opposite end of the lay. These shuttle boxes, containing each a shuttle, are shifted to form the check or plaid in the following manner:—

A wheel, containing one-half the number of teeth which the complete check or plaid to be woven contains threads, is placed on a stud-pin, round which it revolves, at right angles with the lower end of the levers, on the top of which are the toothed arcs or segments. This wheel is moved a tooth at every second stroke of the lay, by means of a short arm on the cam shaft of the loom: on the plane of this wheel is affixed two cam plates, whose respective extremities are met by the respective extremities of the two before named levers, as the lay moves forward to beat up the thread. The extremities of the cam plates are indented and protruded alternately as the figure to be woven requires; and when the wheel to which the cam plates are attached performs one complete revolution, the shuttles will have shifted through all the variety of the check or plaid and be prepared to commence the same routine again, without



interrupting the motion of the loom. At every shift of the shuttle boxes, a spring arm drops into a cavity or notch in the edge of the plane wheel on which the shuttle boxes are fixed, by which they are prevented from moving until required again to shift; at which time, the spring arm is raised out of the cavity or notch, by means of a spring fastened at one end of the cam plates, with an inclined plane on the other end, which is acted upon by the lower ends of the levers that move the boxes, before they strike the edges of the cam plates.

The shuttle is thrown from the fixed box to the moveable one by a picker of the ordinary kind, but from the shifting boxes to the fixed one by a picker lying horizontally, the end of which enters into a slot or opening in the backside of the moveable boxes. The loom protects, in case the shuttle fails to box, in the ordinary way, each of the shifting boxes being furnished with a guard, like that in the fixed box, which acts in turn upon the finger on the protection rod.

To secure a correct check or plaid, the loom is made to stop in case the weft thread breaks, or has become expended on the bobbin. On the crank shaft, near the selvage of the cloth, is placed a cam with a concentric offset on one side, to which an arm, hung on a stud, presents its extremity when it is to stop the loom, but at other times lies below it. This arm is raised by every revolution of the cam, so as to be in a position to meet its offset, and is held in that position by a delicate spring catch at the other end of the arm. As the shuttle enters the box, if the thread from the bobbin in the shuttle be entire, it will extend from the edge of the web to the shuttle box; between these there is a small aperture in the reed, or at its end, through which a small horizontal slide will project a little when the lay is fully down; across this aperture and in front of the end of the slider, the thread will lie, (if unbroken,) where it is *held fast by a cramp that falls upon it*, and is pressed down by a spring as the shuttle enters the box, and which is thrown back as the shuttle leaves the box. When the lay moves forward, the thread, thus extended across the aperture and held fast, forces back a little the horizontal slider, which instantly unlocks the before named spring catch, letting the point of the lever or arm fall below the offset in the cam; but if there be no weft thread across the aperture, the slide passes through without being driven back, consequently the arm remains locked and instantly stops the loom.

Before closing our observations on looms for weaving fancy textures, we shall offer a few remarks on the manufacture of several

kinds of silk textures, by hand, but which may also be found applicable to power loom weaving, comprising taffetas, gros de Naples, satins, &c., hoping that they may be of service to those of our friends who are not much skilled in silk manufactures.

#### TAFFETAS.

Taffetas should be woven with the warp pretty tight; and as soon as the shuttle is passed through, the shed is to be closed, just before the stroke of the reed is given. This manner of closing the shed before beating up the weft thread, causes a better grain to be given to the cloth. On this kind of texture, the temples must not at any time be at a greater distance from the reed than 2 inches, before changing them, to avoid making a thin place or shire in the fabric. The weaver must give the strokes of the reed with uniform force. Superior taffeta is made with 4 threads per dent of the reed, and inferior with 3 threads per dent.

#### SHINING TAFFETA.

Shining taffeta is more brilliant than that just noticed; and is made with a warp *less light*. The stroke of the reed is given when the shed is nearly full open; which renders the cloth very brilliant in appearance, and does not make it *dry* and *stiff*: what makes it supple, is that the warp is *slacker than in other taffetas*. In weaving this fabric great care must be taken that *the weft threads be laid evenly together*, (for more than one thread is generally used,) and when the shuttle is passed through the shed, the weaver must see that the thread from the shuttle lies properly, neither too tight nor too slack. Care must also be taken that the weft thread be always delivered from the shuttle with perfect uniformity of tension; otherwise, there will be *ins* and *outs* in the selvages, giving the edges the appearance of a *carpenter's saw*. The *French* are very particular, indeed, in attending to these matters, which is the principal reason why their goods always feel so *smooth* and *soft* to the touch. The *great secret* in manufacturing these silk textures, is to make the *greatest possible show with the least expense of material*.

#### GROS DE NAPLES.

Gros de Naples is woven with the warp pretty tight in the loom, that the silk may more easily disengage itself when the shed is being opened; and the weft must be well struck up. There must be

two strokes for each passage of the shuttle, the first with open shed and the second with close shed: if only one stroke were given to each crossing of the weft thread, it would have to be given with greater force; but then the fabric would not be so good; whereas, in giving two moderate strokes, the cloth will be perfectly even. Clean white paper must be put on the cloth roller, as fast as the fabric is wound on; because this texture having a thick warp and weft might become watered by the vibration given to that roller by the stroke of the reed.\* Gros de Naples is made with double and treble threads in the warp, and with 4 threads in the dent of the reed. The weft is composed of 3 or 4 ends put together, or according to the thickness of the cord wanted in the fabric: for fine gros de Naples, there are of course, fewer ends used in the weft, but 4 ends is the number generally employed. In weaving gros de Naples of inferior quality, one stroke of the reed, only, is given to each thread of weft: but when the quality is to be superior, two strokes are indispensable, in *hand looms*. Since the introduction of the new mechanism, invented by C. G. Gilroy (see Section Twelfth) to the power loom, in combination with Jacquard machinery, not only these fabrics, but all fabrics, of silk, or of other materials, generally, can be manufactured with the greatest facility and profit. These improved looms have received the approbation of the most skillful manufacturers of England, Ireland, Scotland, France, Belgium and Prussia. (See testimonials at the end of Section Twelfth.)

#### THICK SILK CLOTH.

Thick silk cloth is a fabric made with 4 threads, *double* or *treble*, in the dent of the reed, according to the quality; and it is generally manufactured in a loom with 8 or 10 leaves of headles, half of which are raised and depressed alternately. The reason for using so many headles on plain texture, is to prevent the warp from being crowded in the headles. The warp is not kept tight in the loom, particularly when it is wanted to cover well. The pace weights which govern the tightness of the warp, must be moveable, and there should be one weight on each side of the beam or roller, so as to strain equally. There must be a whip roller, turning on gud-

---

\* We have laboured 15 years, in France and Great Britain, to produce as perfect silk and other goods, plain, tweeled and figured, in the power loom, as could be effected by the most skillful weaver, by hand; and how well we have succeeded, our friends will be better able to judge after reading the proofs set before them in next section.

geons or journals, placed at a proper height to suit the headles ; and over this roller the rope must be passed (see Figs. 219 and 220 ;) which roller will roll with the silk as fast as the cloth is taken up on the cloth roller and prevent the evil effects which would be continually caused by the decreasing diameter of the warp beam.

It requires a very skillful weaver to make a good silk fabric, and even in France the manufacturer is often at a loss for competent workmen ; some who have worked at this business for 30 or 40 years, not having paid sufficient attention *have not become good weavers* ; while others have obtained ten times the amount of knowledge in one-fifth of the time.

The weft thread repeats 4 times in the middle of the selvage (in this kind of texture) and only twice in the edges : the selvages work in opposition to each other, that is to say, when one selvage is opened on the right the other is closed on the left, and vice versa. This prevents the weft thread from following the shuttle back again. A piece of silk goods is never considered well woven unless the selvage is perfect in every respect, and entirely free from hills and hollows on the outer edge.

#### SATIN.

Satin is made of different widths, from  $\frac{1}{4}$ ths to  $\frac{3}{8}$ ths of an aune (44 inches, French) and of various lengths of web ; and has from four threads to ten threads per dent in the reed. When only four threads are entered per dent, only five leaves of headles are used ; which headles are made of raw silk.

This kind of fabric is dyed after it is woven, and is used only for making hats and artificial flowers. Black satin is generally made with a double warp, when intended for making the crowns of hats, caps, &c. The sleeking tool is used for all satins, except those of 4 threads per dent of the reed ; to these a soft brush is applied instead. Three or four dents at the edges of the cloth are gros de Tour (same as selvages of gros de Naples.) Sometimes the selvages to satin fabrics are zig-zag in the middle and the rest gros de Tour.

In weaving a superior satin, the warp must not be too tight ; and it must be worked with an open stroke, so that the weft may be perfectly tight and straight. The warp must be well *picked* before being put into the loom, *by a Lyons silk picker* ; or else it will be impossible to make a fine satin.\* For these kinds of textures, the headles should be 16 inches in depth.

---

\* A Lyons silk warp picker, or cleaner, costs 1600 francs ; and may be procured on application to M. Dioudonnat, No. 12, Rue St. Maur, Paris.

## HEADLE-MAKING MACHINE.

John Blackmar, of Brooklyn, county of Windham, Conn., obtained a patent for a machine for making headles, bearing date October 20th, 1836; a representation of which machine is given at Fig. 192.

Fig. 192.

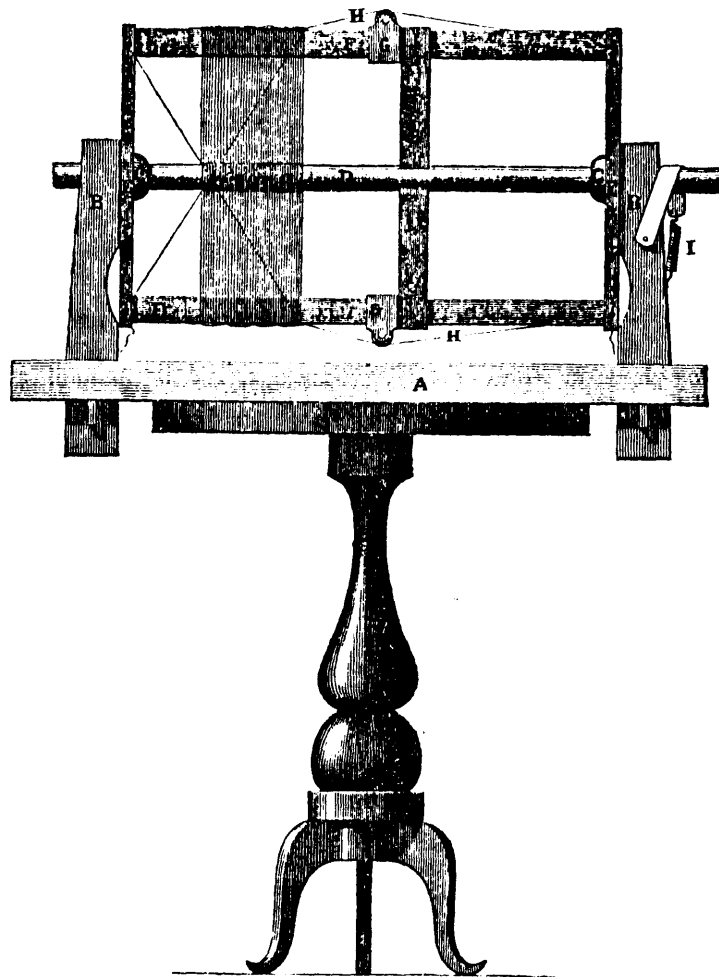

The patentee observes, that "this machine may be constructed in all essential respects like those now in common use, excepting the application of that principle which makes a part of the machine a

bench susceptible of a rotary or revolving motion." This is effected in the following manner:—

A, Fig. 192, represents the bottom of the machine or bench; B B, side posts, carrying the shaft D, having suitable gudgeons C C, at its ends: these gudgeons C C, pass through the end pieces E E, and these end pieces are made fast on the gudgeons C C; F F, side pieces of the frame on which the headles are constructed; J J, brace to hold the shaft D, and the side pieces in their proper places to keep them from sagging; G G, slide-stands, each carrying a small pulley over which the muddling twine or binder H H, passes: the slide-stands G G, may be shifted by the operator to any position best suited to facilitate the work; I, spiral spring, for the purpose of holding the shaft D, in any desired position.

Mr. Blackmar claims as of his invention the revolving principle of the headle frame; whether constructed in the way described or in any other way. It is curious that a patent should have been granted for a revolving headle-frame so late as the year 1836, when it has been well known, and, in fact, the only machine used for making headles in Lyons, Paris, Rouen, and many other manufacturing places in France these 30 years past, and has been of late introduced (from France) into Spitalfields. It cannot, therefore, be the subject of a valid patent in the United States of America; yet Mr. B. possibly may have had no knowledge of its existence elsewhere previous to the date of his patent.

A patent has been secured in America, for a peculiar method of forming the eyes of headles, which consists of a double knot, one

Fig. 192 $\frac{1}{2}$ .



on each side of the eye, as represented in Fig. 192 $\frac{1}{2}$ . The side A, is perfectly straight, whilst two single knots are formed on the side B, each of which encloses the side A, when drawn tight, the eye being formed between the two knots, so that in the up and down motion of the headles, the warp threads are pressed against the knots, which being hard tied, are not so likely to cut the eye as if they pressed against a single loop of the headles. C D, are the headle shafts. This improvement, we think, is a *valuable* one, and well worthy the attention of cotton manufacturers, particularly those of them more immediately engaged in making fine goods.

As these headles are generally made of cotton yarn, they would

soon wear out unless protected by a suitable varnish being rubbed upon them. We shall lay before the reader two methods of doing this; for the first of which we are indebted to Mr. James Montgomery, superintendent of the York factories, Saco, Maine. Mr. M's varnish is made of the following ingredients:—

1 Gallon Linseed Oil,	$\frac{1}{2}$ Lib. Umber,
1 Lib. Litharge,	$\frac{1}{2}$ do. Gum Shellac,
1 do. Red Lead,	$\frac{1}{4}$ do. Sugar of Lead.

All these, except the shellac, are first well boiled over a moderate fire, until the strength is out of the lead; the shellac is then added, but only a little at a time, while the whole is boiling, and it requires to be well stirred all the time. When the shellac is entirely dissolved, the whole is then cooled down to blood heat, then a sufficient quantity of the spirit of turpentine is added, to make it fit for use. Such articles as require it, are to be pulverised. Before putting on the varnish, the headles should be brushed down with paste or size from the dressing machine: and after the varnish is thoroughly dry and hard, they should be again brushed down with tallow, to smooth them well before they are put into the loom. Headles properly varnished in this manner, and perfectly dried before they are used, will generally last over one year.

This receipt of Mr. Montgomery's is, no doubt, a very good one for common headles, for weaving the coarser descriptions of shirting &c.; indeed, it appears to be the only kind of varnish used for headles in the United States; but for weaving fine goods, such as muslin, &c., the following receipt will be found far superior, as headles varnished on this plan will not *chafe* the warp; and, after 5 or 6 days working, on either power or hand looms, will become as smooth as glass.

*Varnish for Headles.*—2 gallons linseed oil, boil slowly  $1\frac{1}{4}$  hours; then add 32 ounces gum shellac, boil 20 minutes, then add 32 ounces red lead, boil 20 minutes; then add 16 ounces umber, boil 20 minutes. This done, take the varnish off the fire, and add 2 gallons spirit of turpentine. The varnish must not be very hot when the turpentine is added, to prevent it from taking fire. In making this varnish, it is to be constantly stirred; and the several ingredients of which it is composed must be added slowly.

Note. In boiling the various ingredients, the manufacturer may use his own judgment as to the time when each of them becomes properly dissolved: but we think the foregoing directions will be found pretty correct.

*Application of the Varnish.*—In applying this varnish, it must

be mixed with *flour size*, and three coats should be given of the composition thus formed. Make the first coat of 1 part varnish and 3 parts flour; the second, half varnish and half flour; and the third, 3 parts varnish and 1 part flour. Let one coat be dry before putting on another. The headles should be hung up in a warm room while the various coats are drying.

In this receipt we have stated only small quantities of the different ingredients, but as the proportions mentioned are correct, they may easily be increased to any desirable extent. We have used varnish of this kind on the front headles of damask looms for weaving table cloths, piano-forte covers, furniture stuffs, and other descriptions of figured goods, for upwards of 18 years; and we can testify that it is the best composition for this purpose we have ever known: we can, therefore, recommend it, with the utmost confidence, to manufacturers of such fabrics.

#### TEMPLES.

There is, perhaps, no implement about a loom of greater importance than the temple; for it is through its instrumentality that the cloth, as it is woven, is kept at its proper breadth, while the reed beats up against it. As we have already shown the construction of temples used on hand looms (see L L, Fig. 6, page 75, Section First,) it now only remains to show those best adapted to power looms.

Numerous patents have been obtained in Great Britain, France and America, within the last few years, for improvements on temples, so as to render them more applicable to power loom weaving, by obviating the necessity of shifting them on the cloth, as is required in hand loom weaving. The contrivance which has been found to answer this purpose best, particularly for stout textures, is the "American nipper" or "jaw temple."\*

Fig. 193, represents a plan view of the nipper or jaw-temple; Fig. 194, a side or edge view; and Fig. 195, a detached part of Fig. 194, on an enlarged scale.

One of these nippers is to be fixed on the breast beam of the loom, at each selvage of the cloth, where it is acted upon by the motion of the lay, which opens the jaws or chaps of the nippers

---

\* The principle of this temple appears to be the same as that of the temple used by E. K. Arphaxad, on his great vertical weaving engine, invented many thousand years ago. (See Introduction.)



every time the cloth is struck up, and permits the cloth to be slid forward towards the cloth roller.

Fig. 193.

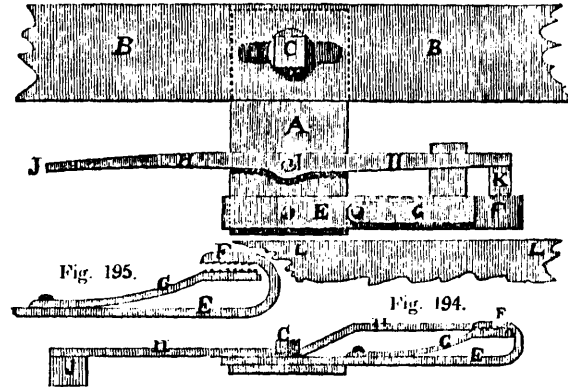

The plate A, to which the nippers are attached, is to be fixed to the breast beam BB, by means of a screw bolt C, as shown in Figs. 193 and 194. The long slot D, made in the plate A, (Fig. 193) is for the purpose of adjusting the temple to suit different widths of cloth.

At the extremity of the plate A, (Fig. 193,) a bar E, is fixed; which bar is turned-up at one end (see Fig. 194) for the purpose of forming the upper chap F, of the nippers. The under chap G, (Figs. 194 and 195) is a spring-piece, and is pressed against the chap F, by its elasticity. The inner surfaces of the chaps F, and G, are guttered out, like a rasp or coarse file, to enable them better to hold fast the cloth.

The lever H H, (Figs. 193 and 194) turns on the fulcrum-pin I; which pin is fixed in the plate A. At the left end of this lever H H, there is a flattened-out or broad-piece J, (see Fig. 191,) and at the right end a knife-edged wedge-piece K.

The lower part of the front of the lay is partially represented at L L, which, when it moves towards the breast beam to strike up the cloth, comes in contact with the end J, of the lever H H, thereby causing the wedge-piece K, at the other end, (to the right,) to be forced in between the chaps F, and G; by which means, the cloth is released at the moment the lay is full up against it; but whenever the lay retires, the wedge-piece K, slips back out of the chaps F, and G, and the cloth is again grasped by the temple.

It will now be perceived that the cloth will be released every

time the reed comes in *contact* with it, and grasped again by the chaps or jaws F, and G, the instant that the reed *begins to retire* from it; thus enabling the temple to hold out the cloth to the same width at which the reed held it.

This kind of temple should be so fixed on the breast beam as to enable it to take hold of the selvage within *half an inch of the reed, when the reed is full up against the cloth.* For very stout goods, the chaps or jaws should, if possible, be brought within  $\frac{3}{8}$ ths of an inch of the reed; by which means the cloth will be kept better extended. This temple is certainly a valuable acquisition in power loom weaving, and well worthy the attention of manufacturers generally.

The rotary temple, which is also an *American* invention, was made the subject of a patent in the United States, by Mr. Ira Draper, of Weston, Mass., January 7th, 1816; and the same gentleman obtained a second patent, for improvements thereon, April 1st, 1829. We shall at present turn our attention to Mr. Draper's improved temple.

Mr. Draper remarks, that, as many defects were discovered by subsequent experience in the working of his temple, patented in 1816, they have given rise to the following improvements in its construction.

The wheel with oblique teeth, similar to the first plan, revolving on a centre pivot (like that marked H, Fig. 196) is riveted or screwed into an iron plate (like that marked I, Fig. 196 :) this plate has two grooves made in it, to receive two screws, to confine the plate down (see Figs. 196, 197 and 199.) The grooves are calculated to admit of changing the position of the temples, to suit the width of the cloth to be woven, similar to the method patented in 1816.\* A metal ring surrounds the wheel and teeth, or the wheel may be altogether of metal, and has a bar across the upper edge, with a hole in its centre having a screw cut in it, by which it is screwed down on the centre pivot. A short angular groove in the upper edge of the ring receives the cloth, and *guides it exactly at the required distance.* A notch being filed or cut in the edge of the ring over which the cloth passes, causes the teeth to leave the cloth freely. For the greater convenience of adjusting the temples, without unscrewing the screws above referred to, a thumb screw is

---

\* As the principle of Mr. Draper's temple is the same as that of the temple represented in Figs. 196, 197, 198 and 199, we think it unnecessary to give drawings of it here.

inserted in a lip projecting from the edge of the ring : the lower end of this thumb screw has a groove turned in it, which plays in a groove in the bottom plate ; and, by turning the thumb screw, the rim on the lower end binds on the under side of the bottom plate and confines the ring.

Mr. Draper observes, that one great difficulty in the application of the temples first patented by him, was their being screwed *firm on the breast beam and having no elasticity* ; the consequence was, every time the reed struck the weft, the cloth would give way and *recoil*, giving the toothed wheel a *sudden rotative motion, increasing the wear of the temples ten fold and enlarging the holes* made by the teeth in the cloth. In addition to which, if the shuttle, by any accident, should not reach its destination in the lay-box, but should stop a little short, it would be caught *between the reed and temples*, and consequently break either the reed or the shuttle.

To remedy these objections, a spring is substituted long enough to receive the cloth. This spring is screwed by its centre to a suitable stand, inside of the breast beam, and is long enough to suit the width of the cloth, and is placed as near the reed as safety will permit, and the temples being screwed on each end of this spring gives them an opportunity of moving laterally with the cloth, and obviates the sudden rotary motion.

The improvements claimed by Mr. Draper are, first, the *ring with the cross-bar which confines the toothed wheel* ; second, the *centre pivot on which the toothed wheel turns* ; and, third, the *spring on which the temples are screwed*, instead of being screwed to the breast beam.

William Craig, of Manchester, and John Cochran, of Stockport, have lately obtained patents for improvements on the rotary temple, in England, Ireland, Scotland, and France ; their American patent bears date November 25th, 1841.

This improved temple is a remarkably neat piece of mechanism, easily applied to a loom, and not liable to get out of order, and is certainly well calculated for cotton textures generally.

Fig. 196, is a top view of the temple ; Fig. 197, a bottom view, as seen from underneath ; Fig. 198, an end view, as seen from the side of the loom ; and Fig. 199, an edge view, as seen when standing at the back of the loom, looking towards the breast beam on the left side. The temple represented in the Figs. is the right hand one, a similar one being required at the left.

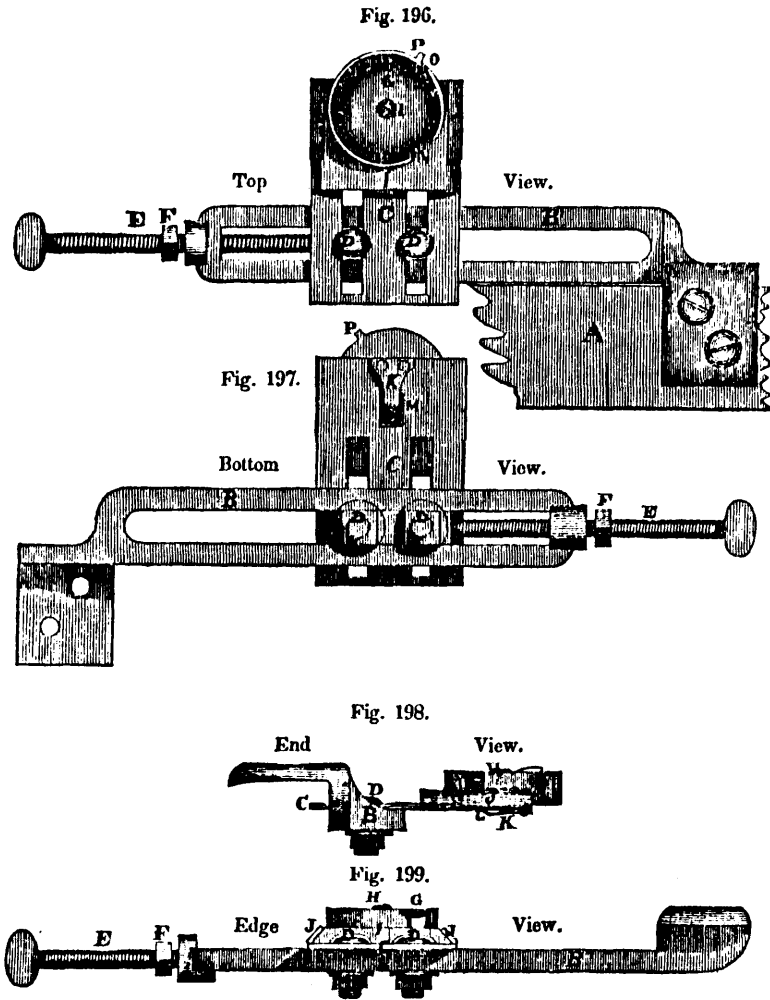

- A, Fig. 196, Breast beam, on which the temple frame is screwed, by two screws, as shown in the Fig.
- B, Frame which carries the temple apparatus.
- C, Slotted piece of sheet iron, with turned-up edges JJ, for the purpose of holding the plate I, which carries the temple.
- DD, Two small bolts to screw down the plate C, on the frame B.
- E, Regulating screw, for setting the temple to suit different widths of cloth, and to keep it firm in its place when adjusted.
- F, Jam-nut, for holding the regulating screw E, in its proper place.
- G, Rotary rim or temple, having teeth round its circumference.
- H, Fulcrum or stud pin on which the rim G, revolves.
- I, Plate on which the temple is fixed and into which the fulcrum or stud-pin H, is screwed, to hold the temple G, down, but permitting it to rotate freely.
- JJ, Turned-up edges of the slotted piece C, for the purpose of holding the plate I, on which the temple G, is fixed.

- K**, Figs. 197 and 198, Small spring screwed or riveted on the under side of the temple, its end being rounded and bent inward, passing through a small slot **M**, cut in the plate **C**, as shown in Fig. 197. The rounded point of the spring **K**, is made to drop into a small notch **L**, made in the back or under side of the plate **I**, nearly opposite the centre of the rim or temple **G**, and is for the purpose of keeping the temple in its proper place *longitudinally*: otherwise, the plate **I**, on which the temple is fixed, might, in the working of the loom, get jarred out from between the turned-up edges of the slotted piece **C**.
- L**, Notch made on the outer side of the plate **I**.
- M**, Slot cut in the plate **C**, to admit the end of the spring **K**.
- N**, Point of the temple at which the cloth escapes during the operation of weaving.
- O**, Point at which the cloth enters.
- P**, Small projection on the exterior of the wheel box (see Figs. 196 and 197.) The selvage of the cloth is *lapped over* this projection, as it passes from the reed through the opening **O**, to the points or teeth of the temple **G**, and from thence through the opening **N**, to, and over the breast beam to the cloth roller, as usual.

There are two small square pieces of iron fitted in the slot of the frame **B**, having each a hole made in it to receive one of the bolts **D**: these square pieces of iron serve to strengthen the sides of the frame **B**, as well as to screw the slotted plate **C**, against; and the pieces are not quite so deep as the frame **B**, into which they are inserted, so that the bolts **DD**, may bind down the slotted plate **C**, firmly against the two sides of the frame **B**, without bending the slotted plate **C**. The bolts **DD**, will draw the slotted plate **C**, gently against the little square pieces, and thus the whole will be secured firmly together.

The temples should be set from the face of the cloth about  $\frac{1}{2}$  inch, and in the working of the loom, should the shuttle not reach its destination in the shuttle-box, but come in contact with the outer edge of the temple-box, the reed will drive or slide the temple-box with its plate **I**, back over the slotted plate **C**, the spring-catch **K**, which holds the plate **I**, being slid out of the notch in the underside of the plate **I**, by the sudden concussion of the shuttle against the outer edge of the temple, *thereby saving the shuttle and reed from injury*. Whenever this accident occurs, the temple plate **I**, must be pressed forward into its place by the weaver: but of course, this accident can only happen when the protector fails to operate.

In power loom weaving, when the shuttle fails to enter the box and stops in the shed, the loom should protect far enough back from the cloth: otherwise the reed would come in contact with the shuttle, force it forward against the fell of the cloth, and, perhaps, break 300 or 400 threads of warp: the warp would also be drawn from the yarn beam a length equal to the breadth of the shuttle,

which would cause much delay, independent of the breaking of the threads.

The principal feature of novelty in this modification of the rotary temple is the *projection* P, on the *exterior* of the temple box (as shown in Figs. 196 and 197,) *over* which the selvage of the cloth is *lapped*, as it passes from the reed through the opening O, to the points of the rotary rim or temple G, and from thence through the opening N, as before stated, this projection *turning* the selvage *downwards*, at the proper angle, to be received on the points or teeth of the rotary rim or temple G; and by these means, the *strain* of the cloth is *partly* taken from the temple, the friction thus caused preventing the teeth from drawing *asunder* the threads of the selvage, as is the case with the rotary temples used heretofore.

The teeth of the temple are inserted (as in other rotary temples) in the rim G, at an angle best calculated to hold down the selvage of the cloth, and prevent it escaping from them; and, as nearly all the strain comes on the projection P, the cloth is not so likely to *escape* from the teeth, nor yet to be *torn* or injured by them, as in rotary temples without such a projection.

The other parts of Messrs. Craig and Cochran's temple, shown in the Figs., do not differ from those of Mr. Draper's, except in the neatness of construction.

#### FORK AND GRID MOTION.

This is a motion for throwing the loom out of gear when the weft thread breaks or becomes exhausted in the shuttle. No less than 43 patents have been obtained, up to the year 1844, by different individuals in Europe and America, who thought they had succeeded in hitting upon something which would effect this object about as perfectly as the nature of the case would allow: but, with only two exceptions, all these schemes, however ingenious, have proved unsuccessful, and, in most instances, have brought poverty and ruin upon their unfortunate authors; a circumstance, alas! of every day occurrence with inventors.

The contrivance which we shall at present consider has been found to answer well, on looms for weaving heavy goods; and from the annexed index of its various parts, aided by the description, we think the reader will be able to understand the nature of its operation.\*

---

\* This motion originated with us, in the beginning of the year 1831, at which period we applied it to a power-loom for weaving *Marseilles quilts*; and the patents obtained in England by Mr. Bullough and Mr. Ramshotbottom, for modi-

Fig. 200, represents a back elevation of a common power loom, having the fork and grid mechanism attached thereto; Fig. 201, a side elevation, in section, of so much of the loom as will enable us to show the application of the motion; and Fig. 202, a plan view of part of the apparatus detached from the loom.

Fig. 200.

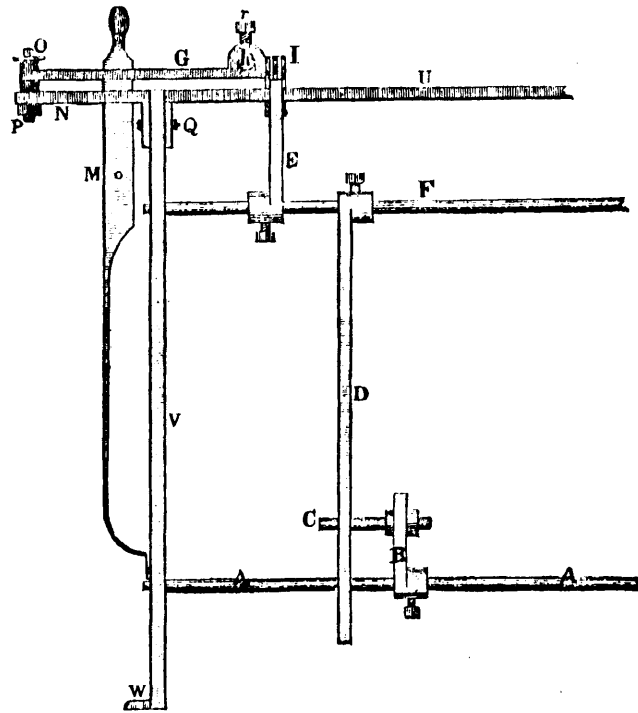

<p>A A, Cam shaft.                  B, Arm fixed upon the cam shaft A A.                  C, Stud-pin bolted in the arm B, for raising the lever D.                  D, Lever fixed on the shaft or rod F; its position, as seen from the back</p>	<p>of the loom, is shown in Fig. 200, and a side view is given in Fig. 201.                  E, Catch lever, also fixed on the shaft or rod F, as shown in Fig. 200, a side view of it may be seen in Fig. 201.</p>
--	---

fications of it, of course, belong to us. We made still further improvements on the motion in the years 1836 and 1838, for which we obtained patents in November, 1839, in the name of Moses Poole, of the Patent Office, 4 Lincoln's Inn, Old Square, London. We also secured patents for the same invention, in France and Belgium, through Henry Trullaut, Esq., patent agent. As we shall have occasion to enter more fully into the investigation of the respective merits of different motions for stopping the loom when the weft thread breaks or becomes exhausted in the shuttle, in the next section, we will therefore, offer no further remarks upon the subject here.

- F**, Shaft or rod fixed underneath the breast beam, or rather a little inside of it, (towards the lay;) it reaches from side to side of the loom, and rests on the frame in suitable bearings.
- G**, Lever working on the stud-pin O. (See Fig. 200.) This stud-pin is secured by a screw nut P, in the outer part of the slotted piece N.
- h**, Round pin made to fit in the socket of the lever G, as shown in Fig. 202, and forms the fulcrum of the fork, the fork working freely upon it: this pin *h*, may be secured at any required distance to suit the proper working position of the fork I, by means of the set screw *r*.
- I**, The fork which plays against the weft thread every time the lay approaches the breast beam: this fork, when it meets with the weft thread, presses it against a few coarse dents in the outer edge of the reed, near the selvage of the cloth, the under extremities of the prongs of the fork entering the dents below; but the resistance of the weft thread will prevent the fork passing through to its full distance, and consequently the other end of the fork, with the hook or catch upon it, will be elevated, allowing the arm B, with its stud-pin C, to give free motion to the lever E, on the rod F, in case the weft thread is not broken or has become expended on the bobbin.
- J**, (Fig. 201,) Lay sword, showing the lay and upper rail L, to receive the reed.
- K**, The race board.
- L**, Upper rail to receive the reed, in the usual way.
- M**, The belt-slipper or spring-rod, for throwing the loom in or out of gear; it is precisely the same as those used in common power looms.
- N**, (Fig. 202,) Stand, bolted at one side of the loom, outside the end of the breast beam, as shown in Fig. 200; in this stand there is a slot made like that marked N, in Fig. 202, into which the slipper M, is inserted in the usual way.
- O**, Stud-pin forming the axis of the lever G, which lever should vibrate freely thereon: the stud-pin O, is bolted firmly in the slotted piece N, by means of the screw nut P, (see Fig. 200;) the place where it is to be inserted is indicated by a small round hole in Fig. 202.
- P**, Screw-nut to secure the stud-pin O, firmly in the extreme end of the slotted stand N, as shown in Fig. 200.
- Q**, (Fig. 200,) Bolt which secures the slotted piece N, to the frame of the loom.
- r**, Set-screw for securing the round pin which carries the grid I, and by which set-screw its distance from the reed is regulated.
- S**, (Fig. 201,) Prongs of the fork I.
- T**, Fulcrum of the fork I, which fulcrum is made upon the bent end of the round pin *h*, as shown in Fig. 202; a portion of this pin *h*, is left out in Fig. 201, in order to show the form of the upper end of the lever E, (which may be called the *hammer*,) and also the shape of the hook or catch end of the fork; the position, however, of the fulcrum of the fork I, (shown in Fig. 202,) is correctly represented at T, Fig. 201; from which explanation, no difficulty can possibly arise to those loom-makers and manufacturers who may wish to construct the motion.
- U**, Breast beam, which may be made of either wood or cast-iron.
- V**, (Fig. 200,) Framing of one side of the loom, which is secured to the floor by means of a suitable bolt passed into the flange or projection W.
- W**, Flange or projection by which the loom is screwed to the floor; there are four such flanges to a common loom, one to each post.
- X**, (Fig. 201,) Post of the loom in section: the other parts in this Fig., being also in section, the ordinary side-framing is not shown in connexion with the post X; and, besides, we wish to avoid every thing which approximates in the least towards *mystification*.

The fork I, is made of wrought iron; it resembles a common eating fork at one end, and is bent as shown at S, Fig. 201; the other end, or that nearest the breast beam, is made flat and formed into



Fig. 201

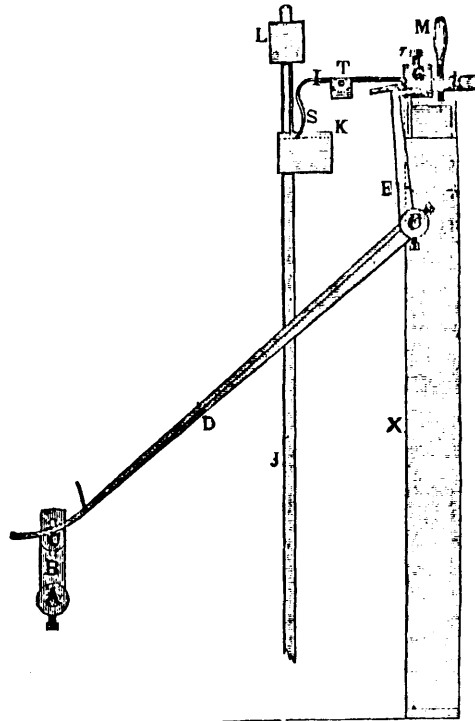

a hook, as represented in the Fig., for the purpose of catching the hook or shoulder of the lever E. The flat end is made a little heavier than the fork end which plays into the reed, so that it may always fall on the hammer of the lever E, unless raised by the action of the weft thread, or rather the action of the fork coming in contact with the weft thread and carrying it against the reed, thus causing the hook end of the fork I, during the forward motion of the lay, to be raised out of the jog in the upper end of the lever E, so that this lever will always miss the hook or catch and pass on without interruption, until the weft thread is broken or becomes exhausted in the shuttle.

The levers E, and D, are fixed firmly, by set screws, on the shaft or rod F; and motion is communicated to them from the cam shaft A A, (see Figs. 200 and 201,) by means of the slotted arm B, and stud-pin C, which pin may be regulated (up or down) in the slot of the arm B, (see Fig. 201,) according to the distance that is necessary to move the hammer on the upper end of the lever E, forward,

for the purpose of unshipping the belt from the tight pulley on to the loose one.

Now, it will be evident, that so long as the weft thread continues unbroken, the loom will continue in operation; but should it break, or cease to be delivered, the fork will meet with no resistance, and will consequently pass through the reed to the full distance to which it is regulated, thus allowing the bent nib or hook at its other end, near the breast beam, to fall on the hammer at the upper end of the lever E, first dropping on the inclined back projection of the hammer, but during the forward motion of the lay, the nib or hook will slip into the jog or notch, as represented in Fig. 201. The stud C, will now act on the lever D, and, consequently the lever E, by means of the jogged hammer at its upper end, will carry the fork I, with the lever G, and the round pin *h*, which forms the fulcrum of the fork, forward, until the side or edge of the lever G, comes in contact with the belt-shipper M, and drives it out of the jog or notch N, as represented in Fig. 202.

Fig. 202.

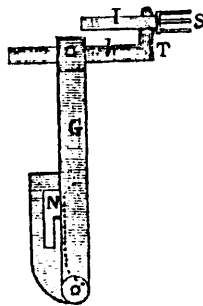

There is a small plate, with three or four wires fixed in it, in the form of a coarse reed, for the points of the grid (at K,) to work through, as the reed could not stand the wear and tear of continual use; besides, the prongs of the fork could not be made to work with precision through the reed, unless it were very coarse.

For coarse cotton goods, the fork need only have three prongs; but for fine goods, such as muslin, four prongs will enable it to act with greater certainty. The reed of the loom in which this motion is to be applied, should be made to extend beyond the selvage of the cloth on that side of the loom where the fork is to be placed, so that the reed-maker may have room to insert five or six strong dents in it, sufficiently far from the selvage that the *fork may not come in contact with the teeth or outer edge of the temple*. The distance

between these dents should be nearly  $\frac{2}{16}$ ths of an inch, for coarse fabrics, but for fine goods  $\frac{1}{8}$ th of an inch would, perhaps, be better; or, in the latter case, the fork might be made with an additional prong and the distance between the dents remain as in the former instance. In applying this motion to a loom where the reed is not made for the purpose, if it be of sufficient length, a few of the dents may be drawn out, and five or six coarse ones inserted; but should the reed not be long enough to admit of this, a small additional piece may be made with coarse dents, and placed at the end of the large reed; it should be well secured, or the prongs of the fork would be liable to strike against the dents, instead of entering between them, and thus cause much damage.

There is a small piece of brass, of the form of a grid, with flanges at each side, let into the shuttle-race or race-board, and on a level with it; this piece is fastened down by four small wood screws, two at each side; the slots of this piece are well smoothed out, and its upper surface is polished: it has one slot for each prong of the fork I; and into these slots the prongs work at each vibration of the lay: the slots are of sufficient depth to prevent the weft thread from getting under the points of the prongs, for if this took place, the loom would be directly thrown out of gear, although the weft thread remained unbroken. The depth of the slots in the grid piece, and the position of the prongs of the fork I, are shown in Fig. 201; the dotted line below the letter K, points out the depth of the slot.

Should the weft thread break or become expended, however, on the side of the loom opposite to that on which the motion is fixed, while the shuttle is passing towards the motion, the loom will instantly be thrown out of gear; but, on the contrary, should the weft break or become expended during the passage of the shuttle from the motion, the loom will not be thrown out of gear; because the arm B, with its stud C, will not then be in a position to act on the lever D.

If it be desired to stop the loom without losing one pick, a suitable connexion must be formed with the belt-shipper from the other side of the loom for that purpose; which any practical weaver may effect without difficulty. For the generality of goods, however, the motion at one side of the loom, as represented in Figs. 200, 201 and 202, will answer the purpose well enough without any addition thereto.

*Packing Machinery.*—A correspondent in the *Mechanics' Magazine* suggests, that the grease used for machinery about to be

packed, should be subjected for about an hour, to a heat of 230° Fahr. in order to evaporate its watery particles; and that with it be mixed a good portion of fresh-burned charcoal, reduced to an impalpable powder.

*Preservation of Iron from Rust.*—A mastic or covering for this purpose, proposed by M. Zeni, and sanctioned by the Société d'Encouragement, is as follows:—Eighty parts of pounded brick, passed through a silk sieve, are mixed with 20 parts of litharge: the whole is then rubbed up by the muller with linseed oil, so as to form a thick paint, which may be diluted with spirits of turpentine. Before it is applied the iron should be well cleaned.

From an experience of two years, upon locks exposed to the air, and watered daily with salt water, after being covered with two coats of this mastic, the good effects of it have been thoroughly proved.—*Bull. d'Encour.*

*Method of giving a black and glossy coating to cast iron trinkets, and other articles of the same material.*—This composition is simple, and offers the invaluable advantage of efficaciously resisting the action of the atmosphere, and even of weak acids, so that the process may be employed for coating a great variety of cast utensils commonly used in our families. The coating easily fixes itself on cast iron, and may also be used on hammered iron, but with less certainty of success in the latter case than in the former.

Attach each of the articles to be coated to an iron wire bent above into a hook, and apply a thin coat of linseed oil; the coat must be thin, to prevent the oil from running, forming asperities or knots where it collects. Hang them eight or ten inches above a wood fire, so that they may be completely enveloped in the smoke. When they have been thus exposed to a brisk fire for about an hour, lower them so that they shall be near the burning coals, without touching them; at the expiration of about fifteen minutes remove the articles, and immediately immerse them in cold spirits of turpentine.

Any articles which, after this last operation, may be found deficient in brilliancy, or not sufficiently black, are to be re-exposed to the burning coals for a few minutes, and again dipped in the spirits of turpentine.

This process, which may be variously modified to suit different articles, may, from its simplicity, be extensively applied, and will prove useful in all cases in which cast utensils are subject to rapid oxydation.

## SECTION TWELFTH.

### FIGURED WEAVING.

Weave, brothers, weave!—Swiftly throw  
The shuttle athwart the loom,  
And show us how brightly your flowers grow,  
That have beauty but no perfume!  
Come, show us the rose, with a hundred dyes,  
The lily, that hath no spot,  
The violet, deep as your true love's eyes,  
And the little forget-me-not!

*Sing,—sing, brothers! weave and sing!  
'Tis good both to sing and to weave;  
'Tis better to work than live idle,  
'Tis better to sing than grieve.*

Weave, brothers, weave!—Weave, and bid  
The colours of sunset glow!  
Let grace in each gliding thread be hid!  
Let beauty about ye blow!  
Let your skein be long, and your silk be fine,  
And your hands both firm and sure,  
And time nor chance shall your work untwine,  
But all,—like a truth,—endure!

*So,—sing, brothers, &c.*

Weave, brothers, weave!—Toil is ours;  
But toil is the lot of men;  
One gathers the fruit, one gathers the flowers,  
One soweth the seed again!  
There is not a creature from England's King,  
To the peasant that delves the soil,  
That knows half the pleasures the seasons bring,  
If he have not his share of toil!

*So,—sing, brothers, &c.*

DARRY CORNWALL.

The first loom for weaving figured fabrics, by power, which we shall notice, is a damask loom; but before beginning to describe it we shall offer a few observations regarding damask textures generally.

*Damask* is a variegated textile fabric richly ornamented with figures of flowers, fruits, landscapes, animals, &c.; and is a rich, elegant and expensive species of ornamental weaving. The name is said to be derived from Damascus, where it was anciently made, with engines invented by that celebrated individual, E. K. Arphaxad.

The twel of damask is usually half that of full satin (a full satin is woven with 16 leaves of headles, as represented at page 109,) and, consequently, consists of eight leaves, moved either in regular succession, or at regular intervals.

The chief seat of the damask table-cloth manufacture is at Lisburn, Lurgan, and Ardoyne, (near Belfast,) Ireland, where it is considered as the staple, having proved a very profitable branch of traffic, and given employment to many thousands of industrious people.

Damask table-cloths, &c. are manufactured extensively in the town and neighbourhood of Dumfermline, in Fifeshire, Scotland; but, in point of texture, those made in Ireland greatly excel them, and particularly so the goods produced by Michael Andrews, Esq., of Ardoyne, and John Coulson, Esq., of Lisburn; which gentlemen are, *without exception*, the *best* manufacturers of this species of fabric in Europe. Damask table-cloths are also manufactured extensively in Belgium, at Silesia (Austria,) and in different parts of Russia. In the last of these countries the texture is coarse, and is commonly known by the name of *Russian diaper*; the patterns, however, often display great taste; the cloth has but few picks of weft to the inch, but it is passed between two powerful iron cylinders, which flatten out the threads, and give the texture a finer appearance than it would otherwise have; the goods nevertheless wear well, and are much used in the houses of the middle classes.

The Emperor Nicholas holds out every encouragement, through his agents in different parts of Europe, to all workmen of talent in the department of figured weaving. Sixty or seventy of the best weavers in Great Britain, France, and Belgium, have already emigrated to Russia, for the express purpose of establishing manufactures of every description of figured goods in that country.

The table-cloth manufacture in Belgium, is mostly confined to Courtray; the principal manufacturer there is M. Alexandre, a very intelligent and worthy individual. In France the most extensive manufacturer of this kind of goods, is M. E. Feray, of Essonne, Seine et Oise: this gentleman employs about 100 damask looms, and as many for weaving other stuffs; he has two large mills, be-

sides his damask factory, and an extensive machine shop; the tablecloths produced by him are of a very superior quality. Mr. F. obtained his knowledge of this business in Ireland, where he seems to have been a pretty frequent visiter, both before and after commencing it on his own account. We would state, however, that for various reasons which we could name, neither his establishment, nor any other in France, can compete successfully with those of Ireland in the production of linen damasks. Table and piano-forte covers are manufactured pretty extensively in the north of England: but in regard to the finer kinds of linen damask, there is no great prospect of their ever driving the *Irish* manufacture out of the market.

This branch of industry might be established with success in the United States of America. The raw material could be grown in many parts of the country, as the climate seems to be well adapted to it; and until such time as sufficient quantities of flax could be raised to supply the home consumption, a profitable business might be carried on in the production of table and *piano-forte* covers, in all their varieties. We are convinced that 5,500 power looms, at least, could find employment provided that the *influx* of the foreign article was impeded, by suitable import duties: but until this is done, it will be impossible (even for the best power loom machinery in the world) to contend against the manufactures of foreign countries, in a branch of industry, where the most skillful manual labour goes for comparatively nothing; the compensation received by those workmen who are there employed in the manufacture being merely sufficient to keep soul and body together. Even steam power, in such a case, would soon not have a leg to stand upon, in contending against such famished looms; for coals, and the wear and tear of machinery cannot be kept up without some expense. If we were permitted to suggest *locations*, in the United States, where power looms might be erected, we would say, that 500 might be established at Saco, Maine; 500 at Lowell, Mass.; 500 at, or near Providence, R. I.; 500 at Paterson, N. J.; 500 at Troy, N. Y.; 500 at Mannayunk, 500 at Pittsburg, Pa.; 500 at Columbus, Ohio; 500 at Richmond, Va.; 500 in Georgia; and 500 more might find profitable employment in *Iowa* and *Michigan*. These numbers, however, could easily be augmented from time to time, so as to keep pace with the increase of population, as well as to meet the *foreign demand*.

Damasks are woven in the Jacquard and draw looms, and also in the cylinder or barrel loom. Mr. Coulson uses the draw loom en-

tirely, because he *imagines* it to be more *applicable* to his very complicated and extensive patterns; whereas, Mr. Andrews, employs the Jacquard principally, (as do nearly all the other enterprising Irish manufacturers of the present time,) and produces equally perfect work, and as extensive patterns, if not superior to those of Mr. Coulson: but, Mr. C., being a gentleman of the old school, has long since *determined in himself*, to discountenance every valuable improvement which is introduced into the trade, and consequently, his once celebrated establishment is now fading into the "sear and yellow leaf," while those manufacturers of less contracted views are adopting extensively the new improvements as they rise.

In table cloth weaving the ground leaves of headles are generally placed seven or eight inches, in front of the mounting which produces the figure; for, if they were too near the mails of this mounting, they would in working strain and break the warp threads, producing in the face of the cloth little loops, or something not unlike the *ears of birds* (house sparrows.)

Silk damasks are manufactured in great quantities in Lyons, Paris, and several other parts of France, for ladies' shawls, &c.; they are also made pretty extensively in Spitalfields, and Manchester, (England,) and at Paisley, (Scotland.) Damasks have of late years been introduced wholly composed of cotton, in the form of shawls, and other kinds of ornamental dresses; and are mostly exported for the use of the *negro* population, both in *Africa* and *America*.\*

---

\* Messrs. James and Lawrence Holmes, manufacturers (late of Paisley, Scotland) have recently erected 30 or 40 hand-loom at Harsimus, N. J., for weaving imitation and damask shawls. The introduction of this kind of manufacture into America, will, no doubt, be the means of starving thousands of ingenious Paisley weavers; or at least, of compelling them to seek their bread on the American shores. We understand (from report) that an *enlightened* Scotch capitalist has offered the sum of 80,000*l.* for some *new* improvements, lately discovered by an Eastern *antiquarian*, by means of which these shawls may be produced with as much facility as the common brown sheeting which costs nine cents a yard. The price of the fabric, therefore, can only exceed that of common brown sheeting by the cost of material, in as much as the labour in producing it is no greater. It is reported, by the antiquarian *himself*, that a little girl of from nine to ten years of age can tend four or five of his improved weaving engines, which are driven by a powerful *wind-mill*!



Some of the most useful plans of tweeling are as follow :

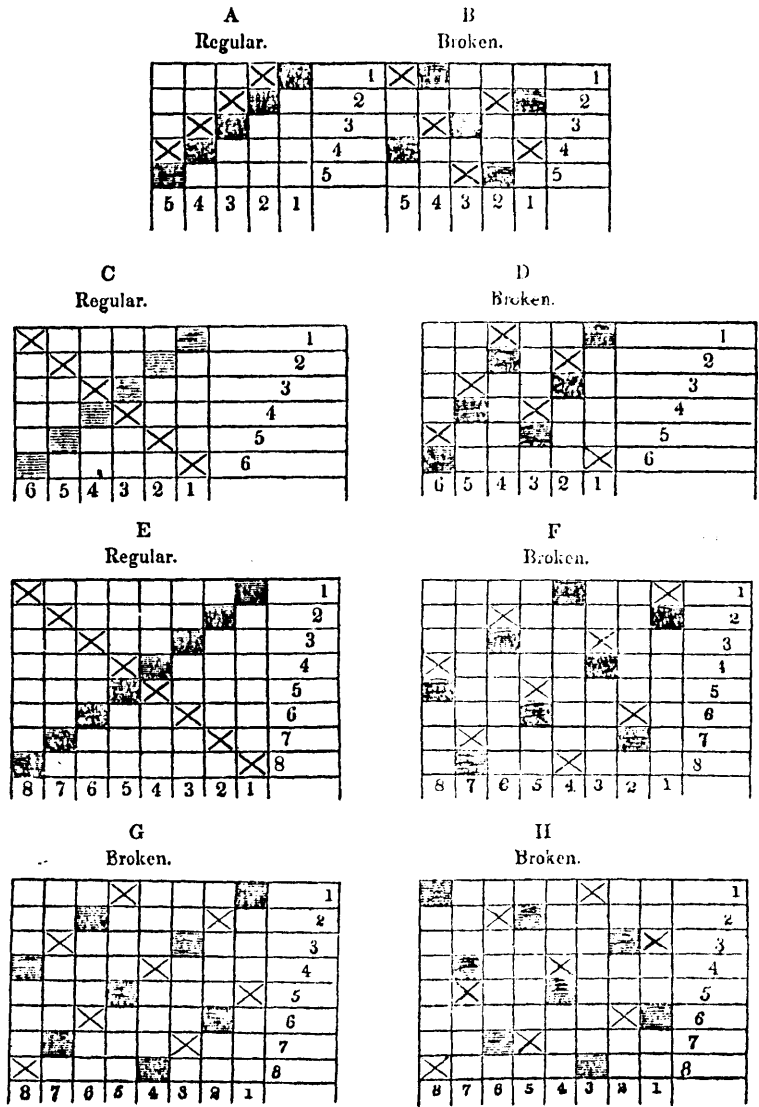

These plans represent the different tweels in use at the present day among manufacturers of damask table-cloths. The tweel marked A, is a regular tweel, and that marked B, a broken tweel; they are both on five leaves of headles, numbered from 1 to 5: table cloths woven with this tweel for the ground are called *bastard damask*. The tweel shown at C, is a six leaf regular tweel, and

that at D, a six leaf broken tweel; they are both woven with six treadles: these tweels are not much used in linen or cotton, being mostly confined to silk damask weaving. E, is an eight leaf regular tweel, and F, an eight leaf broken tweel; they are both woven with eight treadles. G, and H, are two other kinds of eight leaf broken tweels, also woven with eight treadles; that marked H, is most commonly used by table-cloth manufacturers. The cross marks in these plans denote raising cords, and the black squares sinking cords. The methods of arranging the leaves of headles, treadles, &c. (which work the ground,) will be hereafter more fully explained.

Damasks, for table-covers, are sometimes woven with a five leaf tweel, and often with one of eight or even more leaves. When woven with a *five leaf tweel* they are usually denominated *bastard damasks*, and when more than eight leaves are employed for the ground they are called *superfine damasks*. The eight leaf tweel, as before observed, is that which is usually termed the damask tweel.

The number of threads in each mail of these fabrics is likewise variable, being three, four, or more, according to the intended fineness of the web. Taking advantage of this circumstance, the damask weaver has seldom occasion to change his harness, though he may require to change the set of his reed; which is easily done by varying the number of threads in each interval in the same manner. This plan, for the sake of economy, is often carried still farther, particularly where great accuracy is not required, by drawing an extra thread in a mail occasionally at regular intervals, in the same way that weavers miss their overplus headles when the headles are finer than the reed. Damask, however, *when wanted very fine, and when much accuracy and delicacy are required in the design and colouring of the pattern, may be woven in a full harness*; but, as these require a great quantity of cordage, and consequently are very expensive in mounting, *especially when the pattern is large*, the full damask harness is not common.

The Irish damask table cloth manufacturers put 4 threads in the mail generally, and give 4 threads of west to the change of pattern, changing the pattern twice for once over the ground treadles. By this means a finer point is obtained, and, of course, a nearer approach is made to the full harness principle; for, it is evident, that if there were eight threads of west instead of four threads given to the change of pattern, the point would be coarser in the same proportion.

In looms mounted for weaving extensive patterns, considerable

economy is also obtained by introducing what is termed single and double mounting. In the single mounting, every mail, in each part, has a cord and needle to itself, and therefore, can be raised independent of any other; the double mounting is merely certain portions of the border or body gathered. By using these a vast deal of expense is saved in drawing and designing, particularly in extensive patterns.

For example, suppose a damask table-cloth were to be woven, containing 63 porters of warp and 5 threads in each mail, then we have

$$\begin{array}{r} 126 \text{ porters of warp;} \\ 40 \text{ threads in one porter;} \\ \hline 5)5040 \text{ threads;} \\ \hline 1008 \text{ mails in the whole web.} \end{array}$$

Now, these may be divided into parts thus:—

For one side border,	18 designs, single
For the body of the web,	26 do. double;
do. do.	12 do. single;
do. do.	26 do. double;
For the other side border,	18 do. single;
	100 designs;
	10 mails in a design;
	1000 mails;

which deducted from the above given quantity of warp, leaves 8 mails, or 20 dents of the reed for selvages. Here the designer may draw any pattern he pleases for the borders to the extent of 18 designs, or 180 cords of the figuring machine; in the body of the table cover, he may also draw any pattern he pleases on the 12 designs in the centre, as that part is single mounting but it must be such as will join with the 26 designs of double mounting on each side, so as to form all the patterns into one complete group. In this example the tie of the harness will be 180 cords single, of the figuring machine, of the borders; 260 cords double, and 120 single, for the body; making in the whole 560 needles for the Jacquard.

Patterns for damask table-cloths are designed on 10 by 10 paper, and may be woven square, by adapting the number of picks on each change of pattern to the intended thickness of the cloth. Table-

cloth patterns are generally composed of coats of arms, groups of flowers, landscapes, birds, trees, &c.

Damask harnesses are sometimes mounted for the draw loom ; sometimes on the Jacquard plan ; and sometimes the principles of both these are combined, as, for example, when a coat of arms is to be woven in the centre of a table-cloth. In the last case, the borders and part of the body are commonly mounted for the Jacquard machine, while the part for working the armorial bearings is adapted to the draw-boy (see draw-loom.) In large mountings, however, there are frequently four or more simples, and sometimes four or more pulley-boxes, these boxes being placed in the most convenient position for the weaver ; and when any of the simples are not employed, they are tied up and laid aside until wanted in their turn.

It may be further remarked, that, in weaving damasks, in general, when any portion of the harness cords are raised by the Jacquard, to form a flowering shed, these cords must be kept raised by the machine until the proper number of picks to the card is given.

The common damask shawl has uniformly four threads in the mail ; it is woven with an eight leaf satin tweel, like either of those marked F, G, or H, in the preceding examples ; and it may be woven with four or eight picks of weft to the change of pattern. The warp and weft of this class of goods are, for the most part, of different colours.

The loom which now claims our attention, is for weaving table-cloths, bed-covers, window-curtains, &c., and was made the subject of a patent, in the United States, by Messrs. Tompkins and Gilroy, of North Providence, R. I., May 9th, 1835 ; and is the *first power loom with Jacquard machinery*, for weaving these kinds of textures, ever erected in America.\*

---

\* Mr. John Haight, of Harsimus, N. J., obtained a patent, May 17th, 1834, for a power loom, with Jacquard machinery, for weaving ingrain carpets ; and we believe he had some 20 or 30 machines constructed on this principle, in the year 1835, at Messrs. Godwin, Clarke & Co's. establishment, Paterson, N. J., which were put in operation at Little Falls. After persevering, however, for some time, *with a zeal worthy of a better cause*, and expending the round sum of \$30,000, in the undertaking, the whole concern was abandoned, owing to imperfections in the machinery, which it would appear Mr. H. was unable to remedy. We understand Mr. Haight has lately sold this patent for \$60, to a carpet manufacturing company in Massachusetts ; which company also paid him other \$60 for one of his machines. Some alterations have been made upon this loom, by an individual in the employ

Patents were granted to us by the English, French, and Belgian governments for this loom in an improved condition, rendering it available in the manufacture of many kinds of coarse goods; and we believe there are at present in these countries about 340 machines of the improved construction in operation. The British patents are in the name of Moses Poole, Esq., of the Patent Office, London, the French, in the name of P. Aug. Pihet (of the firm of

---

of the company, which appear, from report, to be turning out very advantageous to them. We have been told that as much as \$400,000 has been lately offered, (see New York Evening Post, March 19th, 1844,) by an English firm, of high standing, for the patent-right of the loom in its present improved state; but the offer was peremptorily refused as being *far too trifling a compensation for so valuable a concern*. We regret that we neither can give the name nor address of this firm; but our present belief is, that it must be either the Rothschilds or Baring, Brothers and Co. Few carpet manufacturing companies in Europe could raise such a sum, however willing they might be to purchase the machine; but we do not think they would make much exertion upon the subject, when there are already no less than *seven different* kinds of power looms in Great Britain, weaving Coach lace, Ingrain, three ply, and Brussels carpeting, averaging 20 yards per loom daily, sometimes with as many as 10 or 15 shades of colour, and producing goods of excellent quality. Four of these inventions have been in operation in England since the year 1831; there are we believe three carpet power looms in France, and for which patents have been secured, besides one in Belgium and two in Russia; most of these looms work exceedingly well, and besides possess the merit of being simple in construction.

The statement published in the Evening Post, in regard to the sum of £80,000 being offered by a British capitalist for the carpet power loom therein alluded to, has turned out, as we were sure it would, to be a *falsehood*, see N. Y. Journal of Commerce of June 20.

We have examined models, drawings, and description, lodged in the Patent Office, at Washington, of a loom for weaving carpets by power; which loom was made the subject of a patent in the United States, granted to Erastus B. Bigelow, Esq., Lowell, Mass. May 26th, 1842. The specification and drawings of this patent carpet loom will be given in a work we are preparing which will treat entirely of the manufacture of Carpets and Coach lace, &c. &c. &c., by power; when the various motions claimed by Mr. B. will be compared with those of other parties; manufacturers and others interested, in Europe and America, will thus be enabled to see what truly belongs to each claimant.

---

“When people treat you ill, and show their spite, and slander you, enter into their little souls, go to the bottom of them, search their understandings; and you will soon see that nothing they may think or say of you need give you one troublesome thought.”



Fig. 204.

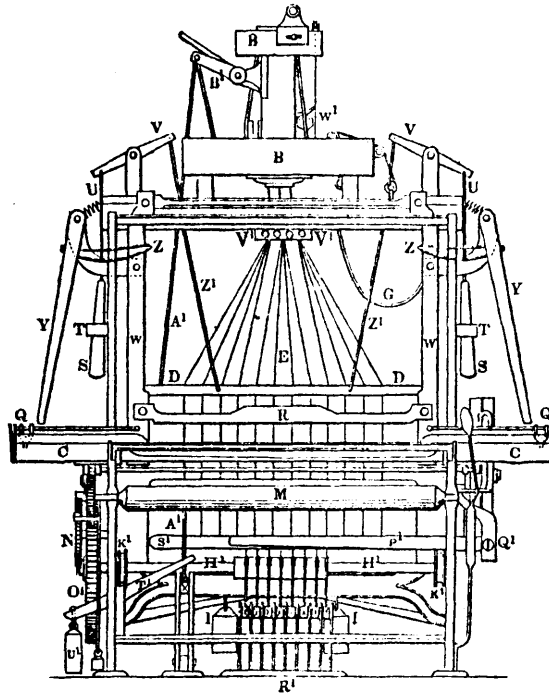

- |   |   |
|---|---|
| <p><b>A A A A</b>, Fig. 203, Frame of the loom.</p> <p><b>B B</b>, Jacquard machine, as constructed by Mr. Thomas Morton, of Kilmarnock, Scotland.</p> <p><b>C C</b>, The lay.</p> <p><b>D D</b>, Leaves of headles for working the ground.</p> <p><b>E E</b>, Jacquard harness, or back mounting, for producing the figure.</p> <p><b>F F</b>, Pattern-cards.</p> <p><b>G</b>, Fig. 201, wires to hold the pattern-cards, at each side, and about four inches from their ends. Into these wires the cards drop as they are delivered from the cylinder.</p> <p><b>H</b>, Fig. 203, The yarn beam.</p> <p><b>I</b>, Fig. 203, Lease rods.</p> <p><b>J</b>, Whip roller over which the yarn passes in its progress to the harness <b>E E</b>.</p> <p><b>K</b>, Stand to support harness board having a governing slot and bolt to raise or depress it, to suit any position required.</p> <p><b>L</b>, The breast beam over which the cloth passes in its progress to the roller <b>M</b>.</p> | <p><b>M</b>, The cloth roller.</p> <p><b>N</b>, Ratchet wheel which communicates motion to the cloth roller <b>M</b>.</p> <p><b>O</b>, Protector, by means of which the loom is thrown out of gear in case the shuttle, from any cause, fails to enter the shuttle-box.</p> <p><b>P</b>, Fig. 203, Arm which connects the lay to the crank shaft.</p> <p><b>Q Q</b>, Fig. 204, Pickers for driving the shuttle.</p> <p><b>R</b>, Fig. 204, Top rail to steady the reed, in the usual way.</p> <p><b>S S</b>, Weights to counterbalance the front mounting.</p> <p><b>T T</b>, Guides to keep the weights <b>S S</b>, in their proper positions.</p> <p><b>U</b>, Wires, or cords, which connect the weights <b>S S</b>, to the top jacks <b>V V</b>.</p> <p><b>V V</b>, Top jacks.</p> <p><b>W W</b>, Swords of the lay, which are suspended above at <b>X</b>, (see Fig. 203.)</p> <p><b>X</b>, Stand to support the lay, one at each side of the loom.</p> <p><b>Y Y</b>, Picker sticks.</p> <p><b>Z Z</b>, Triangles for giving the picker</p> |
|---|---|

- sticks motion; a view of this apparatus will be had at Fig. 203.
- A**, Wire or cord, which connects the Jacquard arm **B**, to the cylinder treadle **C**.
- B**, Jacquard lifting arm.
- C**, Cylinder treadle to which the lifting arm **B**, is connected, by means of the wire or cord **A** (see Fig. 203.)
- D** **D**, (Fig. 205,) Cam wheel to work the treadle **C**, by means of which the lowering shed is opened: this cam wheel is keyed on the cam shaft inside the framing of the loom; its position is indicated at the left, in Fig. 204, by the slotted guide, in which the end of the cylinder treadle is perceptible.
- E** **E**, (Fig. 209,) A modification of the cam-wheel **D** **D**.
- F**, (Fig. 208,) Dog to throw the shuttle, by knocking against the short end of the triangle **Z**, in the backward motion of the lay.
- G**, Adjustable face of the dog **F**, by the bringing of which nearer to, or farther from the fulcrum of the triangle **Z**, a greater or less degree of force, or rapidity of motion may be given to the shuttle.
- H**, (Fig. 211,) Cam shaft carrying eight cams **I**, the form of which is shown more clearly at **J**.
- I** (Fig. 211,) Cams to work the ground headles; these cams may have small rollers at their ends if preferable instead of being plain, as shown in the Fig.
- J** (Fig. 211,) One of the cams **I**.
- K**, (Fig. 207,) Shuttle wheel, divided into 9 equal parts, 5 parts being left solid and 4 parts cut out, as shown in the Fig; the part marked **N**, is double. One of these shuttle wheels **K**, is keyed on the cam shaft **H**, inside the framing of the loom, at each side, as shown in Fig. 204.
- L**, (Figs. 203 and 207,) Shuttle lever having a projection **M**, made upon it, which works in the shuttle wheel **K**: this lever **L**, works on a fulcrum fixed to the framing of the loom, as shown in Fig. 203.
- M**, (Fig. 207,) Projection of the lever **L**, working in the shuttle wheel **K**.
- N**, Double space on the shuttle wheel **K**, for the purpose of causing the shuttle to miss every ninth pick of weft, or every ninth revolution of the crank shaft, although the other parts of the machinery continue in operation; the object of this is, to give the Jacquard machinery sufficient time to operate. In setting the shuttle wheels **K**, on the cam shaft, care must be taken that they be so adjusted in relation to each other as to permit the double spaces **N**, to hold up the projection **M**, of the lever **L**, every ninth revolution of the crank shaft.
- O**, (Figs. 203 and 204,) Cam-shaft wheel, which has nine times the number of teeth of the pinion that works into it, as shown in Fig. 203.
- P**, (Fig. 204,) Counter marches to which the headles **D** **D**, are connected by cording, in the usual way, underneath.
- Q**, (Fig. 204,) Fulcrum of the counter-marches **P**.
- R**, (Fig. 204,) Rack to guide the ground treadles and keep them steady in their respective places: the ends of the treadles are shown in the rack.
- S**, Long march of the cylinder treadle **C**, for the purpose of carrying the wire or cord **A**, which works the Jacquard lifting arm **B**, outside the selvage or warp yarn.
- T**, (Fig. 204,) Small lever, having a weight **U**, at its left end, for counterbalancing the cylinder treadle **C**, to which it is connected.
- U**, Counter balance of the cylinder treadle **C**.
- V** **V**, (Fig. 204,) Small rollers for guiding the neck of the harness **E** **E**.
- W**, (Fig. 204,) Cylinder with the hooks which turn it, in the usual way, as at Figs. 93 and 94.
- X**, (Fig. 203,) The warp yarn.
- Y**, The cloth.
- Z**, (Fig. 204,) Wires or cords, which connect the headles to the jacks **V** **V**.
- The apparatus shown at Fig. 210, is for the purpose of throwing the loom in and out of gear; and to prevent confusion it is not represented in Figs. 203 and 204.
- A** (Fig. 210,) Crank shaft, with the apparatus for throwing the loom in and out of gear fixed on its end.
- B** **B**, Belt pulley on the end of the Crank shaft **A**, having two holes **C** **C**, made in two of its arms, as shown in Fig. 210.
- C** **C**, Holes made in the arms of the



- pulley D", to receive two stud-pins, which revolve with the pulley: these stud-pins are fixed into the slide piece L", and are shipped in and out of the latch wheel D", by means of a lever with a fork working into the hollowed-out place shown between the letters L" L", Fig. 210, as is well understood by all practical machinists.
- D", Wheel with latches E" E", inserted into its outer edges, in opposite directions, as shown in Fig. 210: these latches work on the fulcrum pins I" I"; and the springs F" F", (which must be made of steel) keep the latches E" E", pressed down at their points (opposite to their fulcra,) against the cross-bar H" H", in opposite directions, as shown in Fig. 210.
- E" E", Latches working into the outer edges of the wheel D".
- F" F", Springs to keep the latches E" E", constantly pressed against the cross-bar H" H".
- G" G", Four small set-screws for holding the springs F", F", firmly, two set screws to each spring, as shown in Fig. 210.
- H" H", Cross-piece of the latch-wheel D", forming a part of the wheel D", being cast with it.
- I" I", Axis, or fulcrum of the latches E" E".
- J", (Figs. 205 and 206,) Small roller fixed in the cylinder treadle C", for the cam wheel D", (Fig. 205,) to roll on, by which means the Jacquard machinery is put into operation.
- K", (Figs. 203 and 207,) Lifting-rod connected to the lever L", for the purpose of lifting the dog F", and extends upward, as in Fig. 203, immediately behind the triangle Z.
- L" L", (Fig. 210,) Slide-piece carrying stud-pins for the purpose of throwing the loom in and out of gear. The wheel D" is keyed firmly on the extreme end of the crank shaft A", as shown in Fig. 210, the stud-pins being slid in or out of it at pleasure, by the person who tends the machine: in Fig. 210, the apparatus is full geared, as when the loom is in operation. When the stud-pins, fixed in the plate L" L", are thrown into the wheel D" D", as shown in Fig. 210, the belt-pulley B" B", carries them round inside of the wheel D", until they lock themselves in the ends of the latches E" E", which will be easily accomplished, because the latches E" E", being somewhat larger near their ends, at the cross-bar H" H", will be forced outward by the pins as the belt pulley B" B", revolves, until the stud-pins come up against the cross-bar H" H", whereupon the latches E" E", are instantly shut down upon the pins, holding them against the cross-bar H" H", when the loom continues its ordinary evolutions, until the stud-pins are slid out of the wheel D" D".

In this loom the ground-work of the cloth is considered as being made with eight leaves of headles. If the ground is required to be different, then, the arrangement will of course vary, according to the number of leaves of headles to be used; but to make the machine better understood, we have represented it with eight leaves of headles, and as many treadles to work them, movement to which is communicated in the following manner.

Upon the cam shaft H' H', (Figs. 204 and 211,) are fixed eight cams I' I', each being held firmly by three set screws, inserted at equal distances on the circumference of its hub. These cams I' I', work upon suitable iron shoes, bolted on the treadles (one shoe to each treadle) in regular succession from right to left, until they are all gone over and eight picks of weft given. It is with this design that they are placed spirally on the cam shaft H' H', as represented in Fig. 211. By this arrangement may be obtained all the positions required for

tweeling the ground. The cam wheel  $D'D'$ , (Fig. 205,) is divided

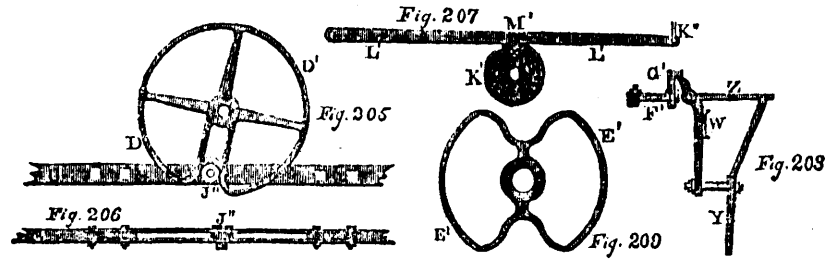

into nine equal parts, eight of which are occupied by the cams  $I'I'$ : the ninth part corresponds to the opening or jog of the cam wheel  $D'D'$ . Motion is communicated to the cam shaft  $H'H'$ , by the wheel  $O'$ , (Figs. 203 and 204,) shown on its axis; and the pinion which meshes into it (Fig. 203) is fixed on the end of the crank shaft, the whole receiving motion from the belt pulley  $B''B''$ , placed on the opposite end of the crank shaft. The number of teeth in the pinion is nine times less than those of the wheel  $O'$ ; that is to say for example, 162 teeth in the wheel  $O'$ , and 18 in the pinion; consequently, the pinion makes nine revolutions while the wheel  $O'$ , is making one; and the lay  $C$ , being connected at each side of the loom to the crank shaft, by suitable arms (one of which is shown in Fig. 203) will bring the reed into contact with the fell of the cloth nine times during one revolution of the cam wheel  $D'D'$ .

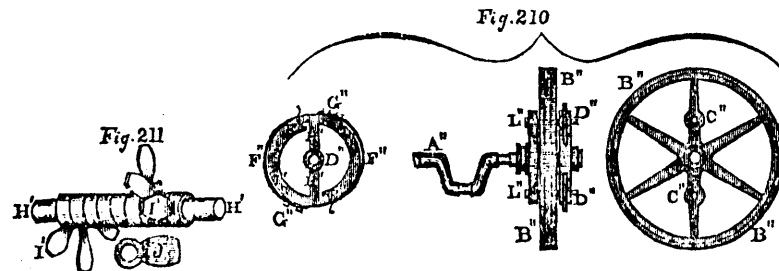

But, it is necessary to remark, that for the satin or tweeled ground chosen (for example) eight picks of weft should be given to every change of the pattern produced by the Jacquard machinery; and while the change of pattern is being effected by the Jacquard, the shuttle should remain at rest, and consequently the ninth stroke of the lay  $C$ , would take place without giving motion to the shuttle. The lay  $C$ , is suspended from the top of the loom the same as in

common hand looms: the picker sticks *Y Y*, are connected to the swords of the lay (one at each side of the loom) by means of crutches (Fig. 204.) Suitable leather straps connect the picker sticks, one to each, to the extreme ends of the triangles *Z Z*, (Figs. 203, 204 and 208.) Motion for throwing the shuttle is communicated to the triangles *Z Z*, by the shuttle wheels *K' K'*, working upon the cam shaft *H' H'*, at each side of the loom (Fig. 204) inside the framing. One of these shuttle wheels is shown separate at Fig. 207; each is divided into nine equal parts, four of which are cut out and the other five project in the form of teeth; the fifth is joined to the fourth, as shown at *N'*, Fig. 207, and makes a double-sized tooth. A lever *L'*, at each side of the loom, as shown in Fig. 203, rests upon one of the shuttle wheels *K'*, and brings to the point of contact with it a projection *M'*, of lance-like form, which, when brought to a projection in the wheel *K'*, raises the lever, and when in the notch, lowers it; and thus the rotary motion of the wheels *K' K'*, elevates and depresses alternately the lever *L'*, so that one of these levers is raised while the other is depressed, except when the two double projections *N' N'*, (Fig. 207) of the wheels act together at the end of their revolution and hold up together. At the end of each of the levers *L' L'*, is joined a rod *K'' K''*, (Figs. 203 and 207,) which is connected to a dog *F'*, (Fig. 208;) this dog *F'*, is attached to the frame-work of the loom above (one dog at each side) in such a way that it may easily move when the lever *L'*, is raised or lowered. In front of the dog *F'*, is adapted to the sword of the lay *W*, a mechanical arrangement (a side view of which is shown in Fig. 203, and a plan, as seen from above, in Fig. 208) of parts which we call a triangle; the triangle will make a circular and a horizontal movement alternately upon its axis. It will be evident, that when one of the levers *L' L'*, is raised by one of the projections of the wheels *K'*, at one side of the loom, the corresponding dog *F'*, which is in connexion with it, through the medium of the lifting rod *K''*, will also be raised; and, on the contrary, it is lowered when the lever *L'*, falls into one of the notches in the shuttle wheel *K'*. When the lever *L'*, is lowered (as shown in Fig. 207) the rod *K''*, allows the dog *F'*, to be also lowered, just before the lay moves back far enough to impede it in its descent, the dog *F'*, dropping directly on a level with the short end of the triangle *Z*, and immediately behind it, will cause the triangle to turn quickly upon its axis, drawing, at the same instant, the picker-stick, with which it is connected by a leather strap, forward rapidly, which in its turn acts upon the shuttle. The rods *K'' K''*, (Figs. 203 and

207,) are a little flattened at their upper ends, forming shoulders, the flat parts take into the dogs F' F', (one at each side of the loom) and the shoulders serve to support the dogs F' F', and keep them from dropping down on the rods K'' K''. One of the slots made in the dog F', is shown at Fig. 208, immediately above the letter F'. According to the arrangement of the shuttle wheels K' K', one of the picker-sticks Y Y, is left at rest, while the other is in motion, and they are both at rest when the large projections N' N', (Fig. 207,) on the shuttle wheels K' K', act simultaneously upon the levers L' L'. At this moment the shuttle is not thrown, and it is then that the cylinder wheel D' D', produces a change of the pattern cards; that is to say, at every ninth revolution of the crank shaft, the lay at this time beating up against the fell of the cloth without adding any weft thread thereto.

From what has been said of this machine, we think no practical weaver or loom-builder will have any difficulty in comprehending the arrangement. In describing it we have not shown the mechanism for governing the giving out of the warp and taking up the cloth, because it is the same as that represented at Figs. 161, 162, 163, and 164; which see.

Figs. 212, 213, 214, 215, 216 and 217, represent a loom for weaving figured fabrics, such as are commonly known under the names of *imperial* or *French quilts*, *imperial petticoat robes*, and also *quilted vestings*; which loom was patented in England, Scotland and France in 1839; and the English patent, which is in the name of Thomas Yates, of Bolton-le-moor, county of Lancaster, was sealed 7th November, in the same year.

The apparatus for giving out the warp and taking up the cloth in this loom, being nearly the same as that now commonly used, we have thought it unnecessary to show it in the Figs.

The improvements consist, in a novel arrangement of mechanism in combination with the various essential parts of the ordinary power loom, for the purpose; firstly, of effecting with greater facility the shedding of the warps, in connexion with the headles, and working various descriptions of cloth, by means of revolving tappet plates, with bowls; and also a certain provision in such tappet plates, whereby the ground may be varied with readiness; secondly, in an arrangement of mechanism for the purpose of lifting and depressing the shuttle boxes, to or from the level of the shuttle-race in the lay, in those looms where two or more qualities, kinds or colours of weft, are to be employed; thirdly, in a certain and effective mode of raising the "griff" of the Jacquard machine in all such looms

where this apparatus is or may be employed; and, fourthly, in a contrivance or arrangement of mechanism, for the purpose of throwing the loom out of gear when the weft thread breaks or becomes

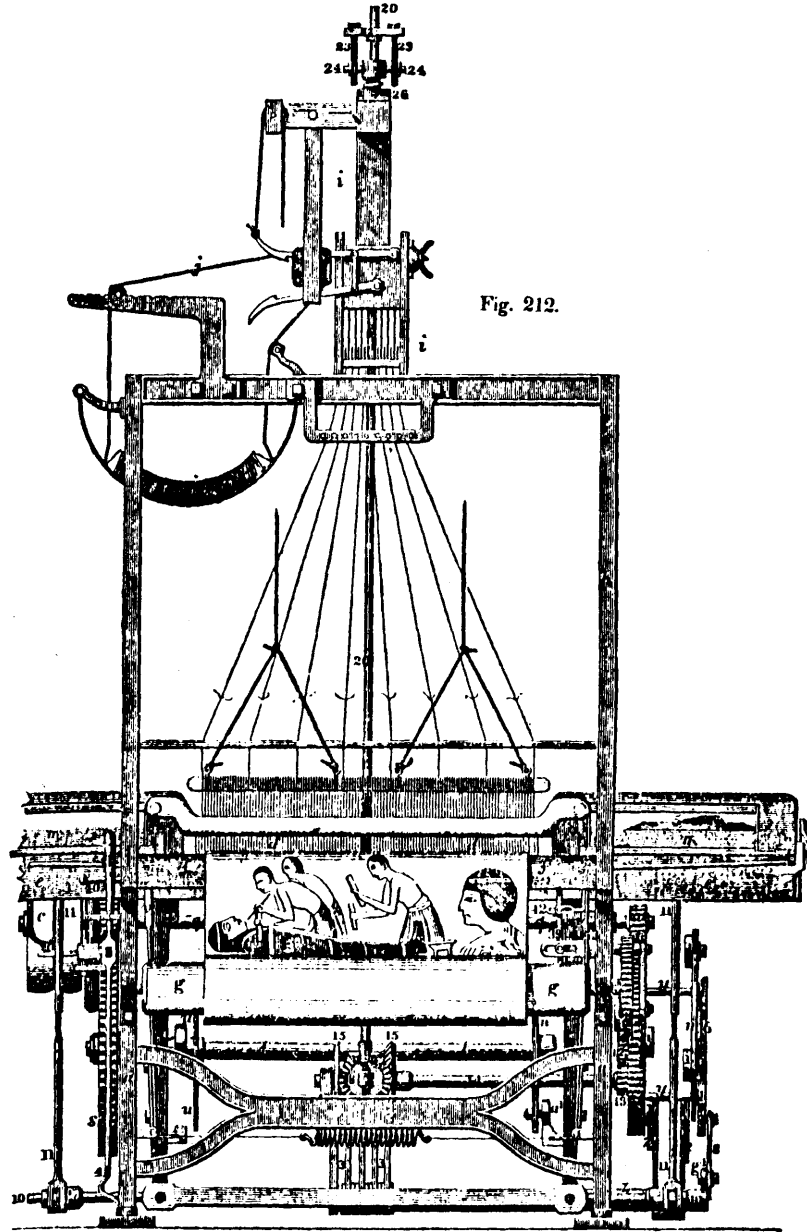
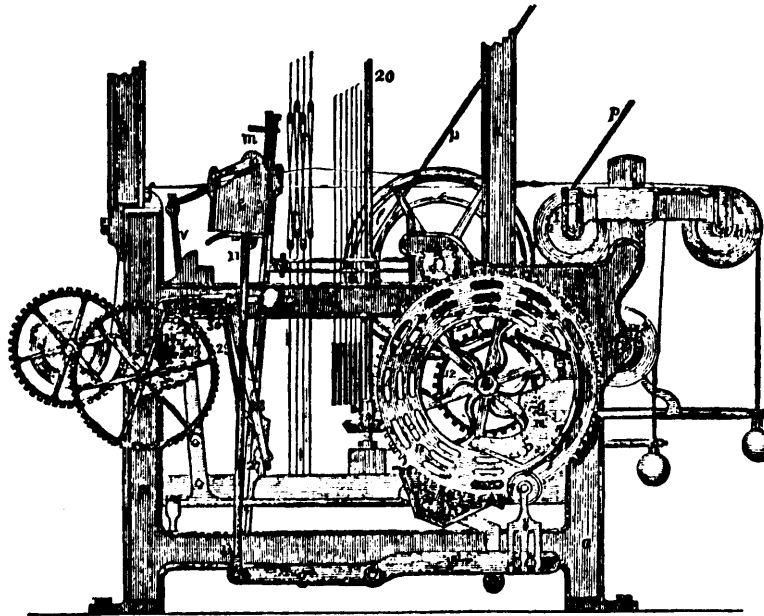

Fig. 212.

exhausted in the shuttle, or when "the taking up" of the cloth upon the cloth roller is not equal to its production; such motion being governed by the ordinary beat or vibration of the lay.

Fig. 212, represents a front elevation of the improved power loom; Fig. 213, a side elevation, taken at the right hand side of Fig. 212; and Fig. 214, is a vertical section, taken through about the middle of the loom.

Fig. 213.



The framing of the loom is marked *a, a, a*, supporting the several warp rollers *b, b', b²*, from whence the warp threads proceed through the headles *c, c*, also through the reed *d, d*, of the lay *e*, over the breast beam *f*, to the cloth roller *g*, as usual. This loom is also provided with an additional framing *h, h*, for the purpose of supporting the Jacquard machine or apparatus *i, i*, with its patterncards *j, j*, hooked wires *k*, and lifting griff *l, l*. There are also two shuttle boxes *m*, which must be raised and lowered to the level of the shuttle-race, as occasion may require; and also peculiarly constructed tappet plates or wheels *n, n*, for the purpose of performing the requisite working of the ground.

The power is to be applied to the driving pulley *c'*, by the strap *p*, and thus, by means of the crank shaft *q*, cause the lay *e*, to beat up the cloth; and also, by means of the pinion *r*, (Fig. 212) and

wheel *s*, upon the tappet shaft *t, t*, cause the tappets *n, n*, to revolve, and thus the alternate motion of the picker-sticks *v, v*, will be effected, as in ordinary power looms.

There is also upon the reverse end of the shaft *q*, a smaller pinion *w*, taking into the spur-wheel *x*, (Fig. 212) fastened by means of bolts *y, y*, to the tappet plates or wheels *n, n*, carrying their respective bowls 1, 1, 1, which act upon the inclined treadle-plates 2, 2, 2, (Fig. 213.) The treadle levers 3, 3, (an end view of which is shown in Fig. 212) are connected by the stringing to the headles *c, c*, and are all mounted side by side, each upon a separate axis, but formed as tubes, and placed one within another to save room; the fulcrum of these treadles is shown at *z*, Fig. 214. This arrangement of mechanism is peculiar to the first part of the improvements in the construction of looms. The tappet plates or wheels *n, n, n*, are provided with concentric slots or mortices 4, 4, Figs. 213 and 216, in which the studs of the bowls 1, 1, are fixed by suitable nuts; and it will be readily understood by any practical weaver, that by loosening the nut or nuts, and shifting these bowls in the concentric mortices 4, considerable variety of shifts, numbers, or changes "to the round" may be thus simply and readily accomplished. The description of cloth, by means of the tappet wheel may be easily varied in plain weaving, or in weaving *grounds* or "*quillings*" in combination with the figures produced by or with the Jacquard machinery, such as single or double cloth, satin, tweeled, plain, or stitched faces, called *quillings*, &c.

The second part of the improvements, namely, the arrangement of machinery for *lifting* and *depressing* the shuttle boxes to or from the level of the shuttle-race, will now be described:—Supposing the tappet bowls, just noticed, to be adjusted to weave a *plain double cloth*, with the employment of *two shuttle boxes*, or a figured cloth, woven in *different colours*, and having a *stitched* or *quilted surface*, the upper shuttle in the box *m*, containing the fine weft, is now just lifted up, as shown in Fig. 212, by means of a concentric tappet plate 6, 6, (Figs. 212, 213 and 217) fastened by bolts to the side of the outer tappet plate *n, n*, (see Fig. 212) as it revolves, acting upon the bowl or roller 7, in the carrier 8, (Figs. 212 and 213) attached to one end of the levers *g', g'*, upon the cross shaft 10. To the other end of these levers *g'*, are attached vertical rods 11, 11, adjustable by a screw in the middle, which enter at the bottom of the shuttle-race in the lay, and thus project the shuttle-boxes, with the shuttles, upwards; the top shuttle is thus kept up out of the shuttle-race, as long as the concentric tappet plate 6, is acting

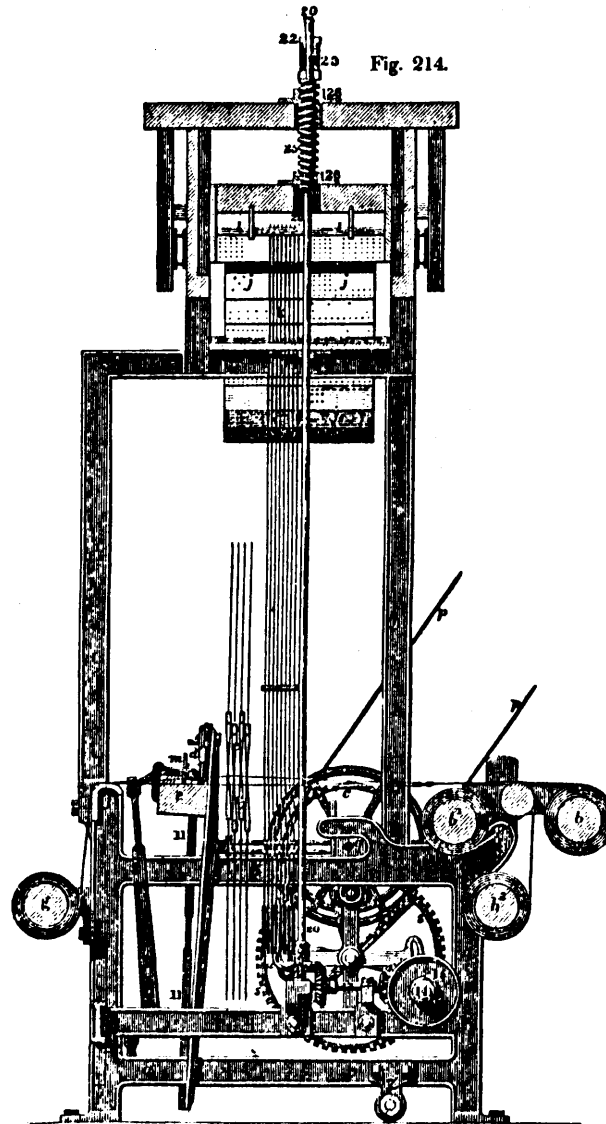

upon the bowl 7;—that is long enough for the lower shuttle, containing coarse *weft*, to put in one pick, prior to the *Jacquard shedding*, and one return pick of the same *weft* after the *Jacquard shedding*, when the bowl 7, will immediately ascend, and allow the shuttle boxes *m, m*, to descend by their own gravity; and thus the upper shuttle is enabled to put in two picks of fine, or coloured *weft*, before the *Jacquard machine* comes again into



operation, and also two picks of fine, or coloured west, prior to the next ascent of the shuttle boxes.

Fig. 215.

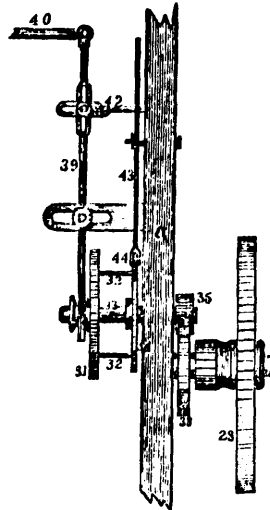

The third feature of the improvement comes into operation, in order to complete the weaving, or to put in the *quilting, or stitching threads, by shedding the coloured warps b', and b''*;—this is accomplished by an improved method of lifting and lowering the griff of the Jacquard machine, in order to insure a perfect regularity and steadiness of action in moving either upwards or downwards. For this purpose a spur wheel 12, 12, is attached, to drive the small pinion 13, (Figs. 212 and 213) keyed upon the shaft 14; and upon the reverse end of this shaft 14, a pair of segments 15, 15, having beveled teeth formed, upon one sixth part of their circumference only, each driving successively, the pinion 16, upon the small cross shaft 17, (Fig. 214;) that is, these segments of teeth are so arranged, that as soon as the one segment of teeth 15, (Fig. 212) has turned the pinion 16, (Fig. 216) one half of a revolution in one direction, the other segment of teeth 15, instantly turns the pinion 16, one half of a revolution in the reverse direction. In order to transfer this reversing motion to the raising and lowering motion of the griff of the Jacquard machine, there is a bevel wheel 18, upon the other end of the small shaft 17, taking into a pinion 19, of half its diameter, at the lower end of the vertical shaft 20, 20, which has, at its upper end, a head-piece 22, 22, having side grooved pieces 23, 23, in which the pins 24, 24, fast upon the

head of the double screw 25, 25, (Fig. 214) work, and thus turn the double screw round. This double screw 25, 25, is cut half its length in reverse directions, and works in the guide 26, which will have the effect of lifting the griff through the required space, in half the time that the crank shaft makes one revolution.

Fig. 216.

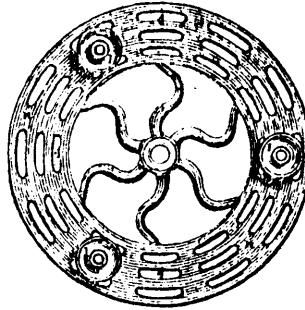

The fourth part of these improvements in the construction of looms, consists, in an arrangement of mechanism, designed for the purpose of throwing the loom out of gear with the driving power, either when the weft breaks or becomes expended in the shuttle, or when the taking up of the cloth is not equal to the production. This is accomplished by the ordinary beat or vibration of the lay itself and *not at all dependent upon the coarseness or fineness of the weft thread*. A stud 27, in the sword of the lay, usually employed for working the taking up motion 28, operates upon a small lever 29, to which is attached the click 30, (Figs. 213 and 214) giving motion to the ratchet wheel 31, one tooth at every beat of the lay. Upon this ratchet wheel are four small pins 32, 32, (see detached Fig. 215, drawn to a larger scale;) this wheel runs loosely upon a small stud 33, which stud also carries a smaller ratchet wheel 34, keyed fast upon it, and having four small holes in its side, *corresponding with the pins in the ratchet 31*; this stud 33, also carries, at its outer extremity, a small pinion 35, which is driven by the spur-wheel 38, upon the shaft of the taking up wheel 28.

Thus it will be evident, to *persons conversant* with power loom weaving, that as the lay vibrates and beats up the cloth; and as long as the weft thread is put in, and the cloth sufficiently beaten up, the taking up motion 28, will cause the pinion 35, to drive the stud and ratchet round; but, in the event of the weft not entering the cloth, and the cloth has not been produced, the lay will not

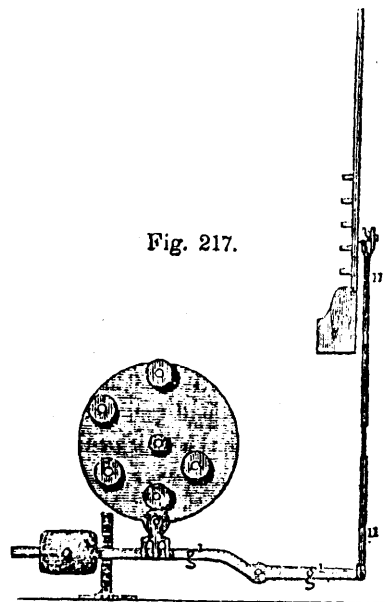

advance sufficiently to drive out the click 30, and ratchet 31, which wheel will now overtake the smaller ratchet, and as they are always held together by a spring behind the pins 32, will immediately enter the holes in the ratchet wheels 34, and thus vibrate the rod 39, which slides the horizontal bar 40, before the lever 41, (Fig. 212) and thus throw the strap from off the driving pulley. The horizontal sliding bar 40, now returns by means of the side motion of the setting off lever 41, and thus releases the pins from the holes. In the two small ratchet wheels there is a catch-piece 42, upon the rod 39; this catch-piece, as it returns, pushes the click lever 43, and click 44, onwards, and just advances the smaller ratchet wheel one tooth, in order to set the holes free of the pins, and thus be ready to start the loom again.

Fig. 216, represents a detached and enlarged view of one of the tappet plates, with its tappets or bowls, moveable in the concentric mortices; and Fig. 217, represents a modification of the mode of lifting the shuttle boxes, and is here shown as capable of lifting and sustaining five boxes.

The apparatus used for working the Jacquard machinery, shown in Figs 212, 213 and 214, answers the purpose extremely well on this kind of loom. That part of the bar or rod 20, which passes through the warp, should be made flat and with round edges, and well polished, so as to prevent strain or friction on the threads

during the operation of weaving. To prevent confusion, we have not represented in these drawings the jacks or couplets which support the headles *c, c*; but any practical weaver of figured goods, as a matter of course, understands that part of a loom.

The reader will not fail to perceive, in Fig. 212, a beautiful representation of an embalming scene, as practised by the ancient Egyptians. This operation was performed on those men who had distinguished themselves by their achievements in their country's cause; and, as a further token of respect, sometimes their brains were picked out (as in the present instance) and carefully preserved at the expense of the Government. For the drawing of this remarkable scene, we are indebted to our old friend, Alexis Kersivenus, who informs us, that the dead gentleman, on whose cranium the physicians are at work, was the first person, in Egypt, who succeeded in weaving a correct representation of the twelve signs of the zodiac.

Erastus B. Bigelow, Esq. of Lowell, Mass., obtained a patent, 30th May, 1842, "*for certain improvements in the manner of mounting the harness, and working the same, in the loom for weaving figured fabrics, such as are commonly known under the names of imperial or French quilts, and imperial petticoat robes.*"

The specification of this patent is of enormous length, full of useless repetition, and the figures which accompany it, cover three large sheets of drawing paper. For this specification and drawings if we recollect rightly, we paid the Commissioner of patents (H. L. Ellsworth) at Washington, the sum of \$17.50.\* The patentee, in summing up his claims, says:

"Having thus fully described the nature of my improvements, in the loom for weaving counterpanes, and other figured articles, and having also, set forth several different modifications thereof, and particularly in the manner of forming and arranging the cams, on the cam shafts, by which the required motion is given to the respective treadles, so as to correspond in their action with the arrangements made in the other parts of the loom, it is to be understood that *I do not claim, nor do I intend to limit myself to the particular arrangement of the cams and treadles, these not constituting a distinguishing or an ESSENTIAL feature of my im-*

---

\* We did not receive the specification and drawings of this loom in time to insert them in the proper part of this Work; but we expect to have another opportunity soon of laying them before the public.

*provements; these consisting mainly, in the mounting of the loom and of tying up the harness, so as to admit of the employment of one, or more, moveable harness-boards, and of one, or more, leaves of headles, and of the Jacquard Machine in the power loom. By this arrangement I am enabled to produce a free and open shed of the warp, and to allow one part, or shed, thereof to descend whilst the other is rising. What I claim, therefore, as constituting my inventions, and which I desire to secure by Letters Patent, is the within described manners or modes of mounting the loom, and tying up the harness, and of working the same, in which, under its various modifications, I combine a moveable harness-board, or boards, with one, or more, leaves of headles, or harness, and with the Jacquard Machine in the power loom, (see Figs. 212 to 217;) such arrangement and combination being substantially the same with that herein described."*

The loom represented at Figs. 212 to 217 was patented three years prior to Mr. Bigelow's loom; and the invention of it took place nearly five years before the date of the patent.

The Jacquard machine used by Mr. Bigelow is of the old construction, *having trap-boards and knot-cords*; and the patentee says in his specification, "*One of the trap-boards is allowed to descend whilst the other rises, without disturbing the action of the knot-cords, and I thereby counteract the unequal action of the harness weights upon the cams by which they are raised.*"

This action of the trap-boards is the invention of James Cross, of Paisley, Scotland; and which he first brought into notice about the year 1818; it is known by the name of "*Cross's counterpoise harness*;" the principle of which is, that *one trap-board rises while the other is sinking*. Mr. Cross's loom is described at page 161, and represented at Figs. 171 to 179; and by examining it attentively, the reader will perceive that the counterpoise trap-boards, on which Mr. Bigelow lays the greatest stress, (in his specification) are there shown to perfection. The raising and lowering of the harness-boards below, so as to govern the shedding of the warps, corresponding to the action of the trap-boards above, is *entirely dependent on the principle* of Mr. Cross's machine. The practical weaver of figured textures, will at once perceive the nature of these claims of Mr. Bigelow. (see page 479.)

The patentee describes, at great length, various forms of cams, which are also represented in his drawings; and by means of these cams, he tells us, the necessary motions are communicated to the headles, as well as to the Jacquard. *Twenty* different figures of

these cams are given, illustrative of their various forms and the positions which we are told they assume during the operation of the loom. The cam-wheel for working the Jacquard corresponds in every respect to that marked D' D', in Tompkins and Gilroy's loom, Fig. 205; the cams for working the headles, &c. are also the same.

It will be observed that Mr. Bigelow, in summing up his claims, says, in reference to all these, that they do not constitute "a distinguishing or an *essential* feature" of his improvements, but remarks, that these consist "mainly in the mounting of the loom, and of tying up the harness, so as to admit of the employment of one, or more, moveable harness-boards, and of one, or more, leaves of headles, and of the Jacquard machine in the power loom." (See Gilroy's loom mountings or tie-ups, Examples Nos. 1 to 10.)

It appears somewhat strange to us, that this gentleman should fill three-fourths of his specification in describing these wheels and cams, and give so many different figures of them in his drawings; and after all this state, that they are not "*essential*" to the working of his loom. Now the truth is, without these, the loom would not be worth a stiver, because it could not produce the stuffs referred to in the specification at all, as any one may perceive by looking at the specification and drawings of this patent, lodged at Washington.

It has been already stated, that Mr. Bigelow claims "the employment of *one or more* leaves of headles, and of the Jacquard machine in the power loom;" which is funny enough. By reference to Figs. 203 and 204, it will be perceived that Tompkins and Gilroy's loom has *eight* leaves of headles, besides Jacquard machinery; and yet their patent is dated May 9th, 1835, whereas, Mr. Bigelow's is dated May, 1842; (see also Figs. 212, 213, and 214.)

Some men admire the heights of mountains, the huge waves of the sea, the steep fall of rivers, the compass of the ocean, and the circuit of the stars, but as for us, we shall for the present content ourself with simply noticing a loom for weaving coach lace, Brussels carpeting, and other fabrics with looped surfaces invented by Thomas Thompson, a subject of Great Britain, and which invention has been Secured by Letters Patent. By the aid of this loom, Mr. T. is enabled to manufacture coach lace at the cost of *one penny farthing* per yard, which formerly cost four pence half penny, exhibiting the astounding difference in favour of Mr. Thompson's machine, over every previous machine, of three pence farthing per yard. To this manufacture he has added the Brussels