



WEAVE IT YOURSELF

BY
FLORA DEE GOFORTH

UNITED STATES INDIAN SERVICE

**WEAVE IT
YOURSELF**

FLORA DEE GOFORTH

WEAVE IT YOURSELF

UNITED STATES INDIAN SERVICE

Photographs by

HELEN POST

Edited by

WILLARD BEATTY

Printed by

HASKELL INSTITUTE



Outfitting the Family—hand-woven shawl scarf, jacket, and coat

**All plates use the Air-Vu technique
of graphic presentation
Drawn by Flora Dee Goforth
1947**

**HASKELL PRINTING DEPARTMENT
April, 1947—1M
Lawrence, Kansas
PRICE \$5.00**

INTRODUCTION

This is a story of simple hand weaving told with illustrations. It covers the fundamental steps of preparing the loom, planning a piece of material, setting up the warp, weaving, and finishing an article.

Weaving is one of man's oldest crafts and has been practiced by many races and groups of people all over the world for thousands of years. During this time, hundreds of different ways of making material for clothing, shelter and home use have been developed. They range all the way from the simple hand method of making mats with grass stems to our present day complicated machine methods of making woven material out of synthetic fibers.

Down through the years, groups and individuals have developed or adapted methods most suitable for their own use. Through this long period of development the fundamental principles of weaving have remained the same. The differences have been in the use of different fibers, equipment, methods of production, patterns, designs and colors.

Most of the woven materials that are used today are made on power machines. The weaving of this material is mass production with hundreds of yards alike in pattern, design, and color. However, there are many people who still enjoy and find it profitable to weave material by hand methods. Hand weaving offers the craftsman a chance for individual expression; it offers to many semi-talented people an opportunity to improve their home surroundings and their personal appearance; and to those who are interested, an income for part or all of their livelihood.

Many Indian tribes and groups started the weaving of materials centuries before the coming of White people and have continued to practice this craft. After the coming of the White man, they adapted his supplies and equipment whenever and wherever they found them to be more useful than their own native things. Several of these tribes are still producing hundreds of hand woven articles in their own way.

There were other tribes and groups of Indian people who never produced woven materials through their own inventions or their own initiative. Some people that originally did weaving have long since lost the art. Recently hand weaving as a home craft has been introduced in various areas through Indian Service Schools to groups of Indian people who were not producing woven materials.

Those who have come to learn this new craft have ranged in age from very young children with untrained hands to old people who have difficulty in understanding or expressing themselves in English. Teaching a new craft to large groups of people with such a wide range in age and interest and being handicapped by the lack of a common oral or written way of exchanging ideas, has presented very special teaching problems. To help solve some of these problems and to make it easier for the teacher to show and explain and for the student to see and understand, this simple step by step illustrated story has been prepared.

This book is a primer illustrating only one of the many ways or methods of doing simple two harness hand weaving. It is for the beginner and makes no attempt to take the craftsman beyond the first stages and into the many complicated processes that can be used in hand weaving.

The suggestions and help of students, teachers and all other interested people who have contributed to the making of this book are sincerely appreciated.

Special thanks goes to my mother who taught me the fundamental principles of many crafts; to Dan J. McQuaid, Sr., who taught me how to make the Air-Vu drawings that are used in this book; to Nellie Buffalo Chief, Ann Roubideaux, Elsie Bonser, Amelia Holy Rock, and Marion Taylor who have taught weaving by this method for several years and who have so generously shared their experiences with me; and to Grace Giroux for designing and weaving the shawl upon which our story is based.

Flora Dee Goforth.

1946

TABLE OF CONTENTS

Part 1.	EQUIPMENT FOR WEAVING.....	7
	A. Loom	8
	B. Parts of the loom.....	9
	C. Putting the loom together.....	11
	D. Reel	12
	E. Skein spreader	14
	F. Heddle board	16
	G. Bobbin winder	16
	H. Shuttles	17
	I. Bench	18
Part 2.	GETTING THE LOOM READY TO WEAVE.....	19
	A. Making the harness.....	20
	B. Tying up the loom.....	23
	C. Making the warp apron.....	27
	D. Making the cloth apron.....	29
Part 3.	PLANNING AND WINDING THE WARP.....	31
	A. Planning a small piece.....	32
	B. Winding a narrow warp.....	34
	C. Planning a larger and more difficult piece.....	42
	D. Winding a wide warp.....	44
Part 4.	THREADING AND ROLLING THE WARP.....	47
	A. Threading the reed.....	48
	B. Threading the harnesses.....	51
	C. Tying the warp to the warp apron.....	54
	D. Rolling the warp on to the warp beam.....	59
	E. Tying the warp to the cloth apron.....	62
Part 5.	WEAVING	64
	A. Moving the warp.....	65
	B. Operating the loom.....	67
	C. Spreading the warp.....	72
	D. Winding a bobbin.....	73
	E. Starting the shawl.....	74
	F. Weaving the shawl.....	79
Part 6.	COMPLETING THE ARTICLE AND VARIOUS THREADINGS.....	80
	A. Starting a new filling thread.....	81
	B. Piecing a broken warp thread.....	82
	C. Finishing the shawl.....	86
	D. Whipping a fringe.....	88
	E. Different threadings on one reed.....	89
Part 7.	TERMS	97

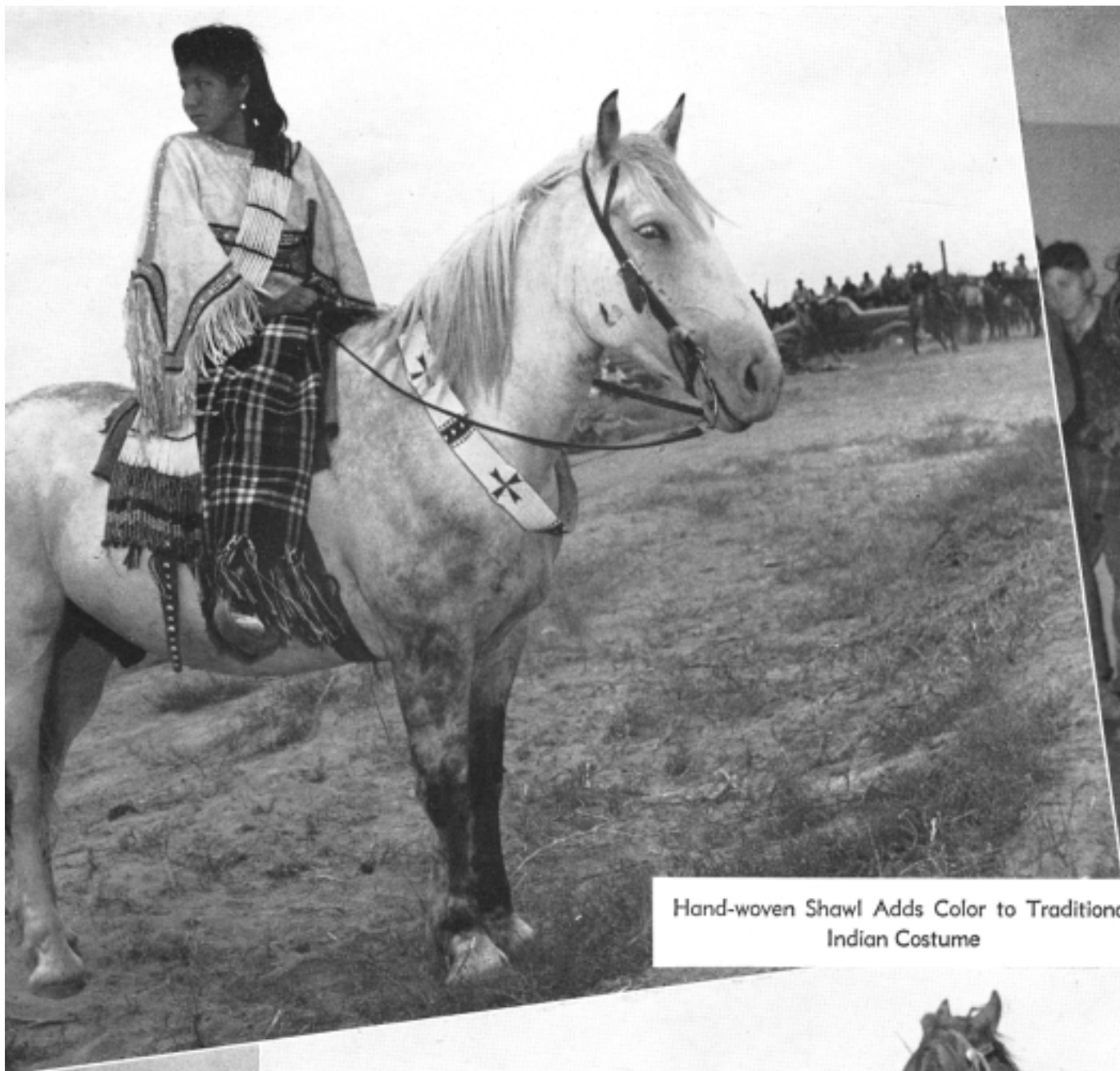

Hand-woven Shawl Adds Color to Traditional Indian Costume

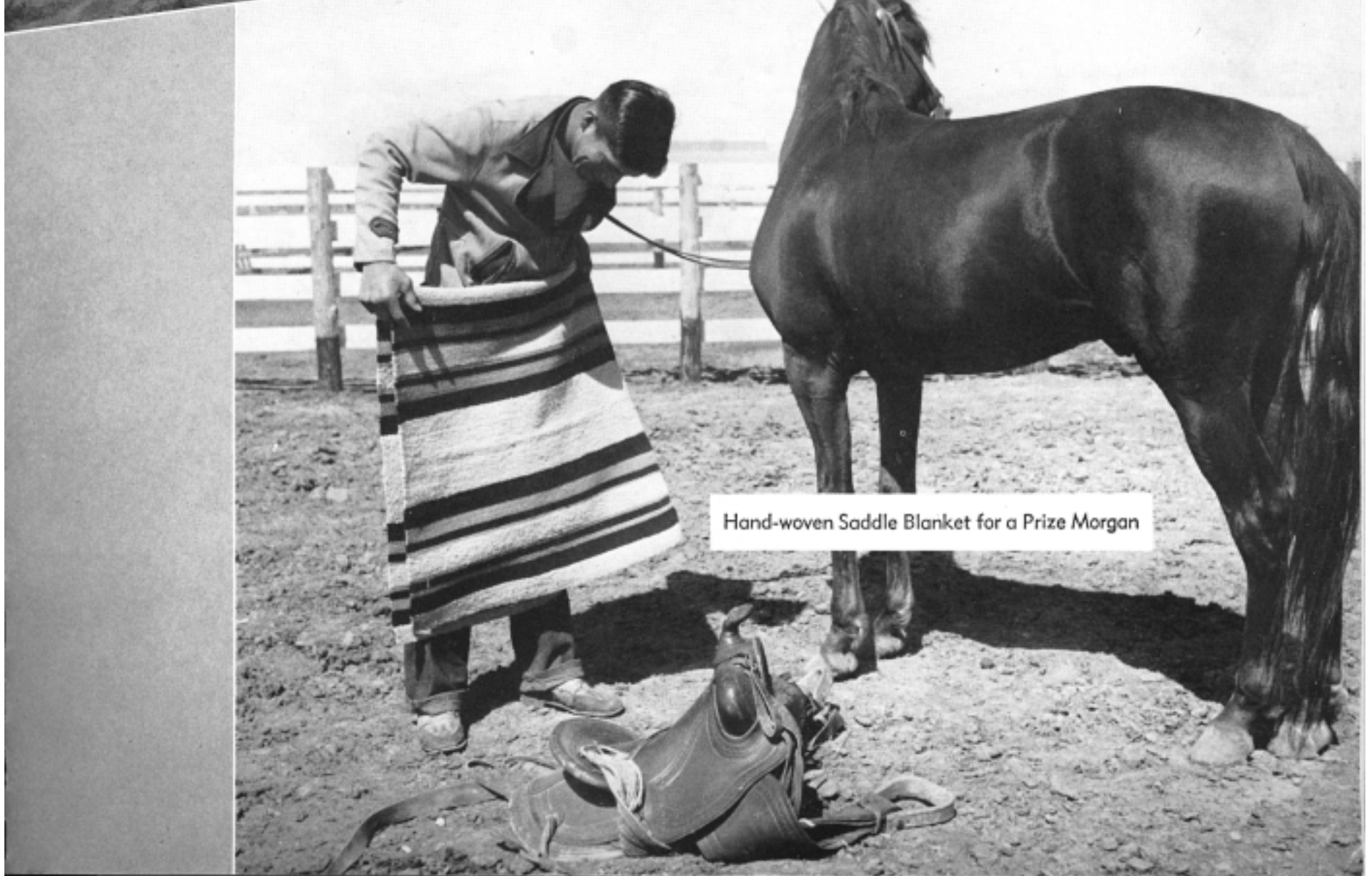

Hand-woven Saddle Blanket for a Prize Morgan

I. EQUIPMENT FOR WEAVING

A. LOOM

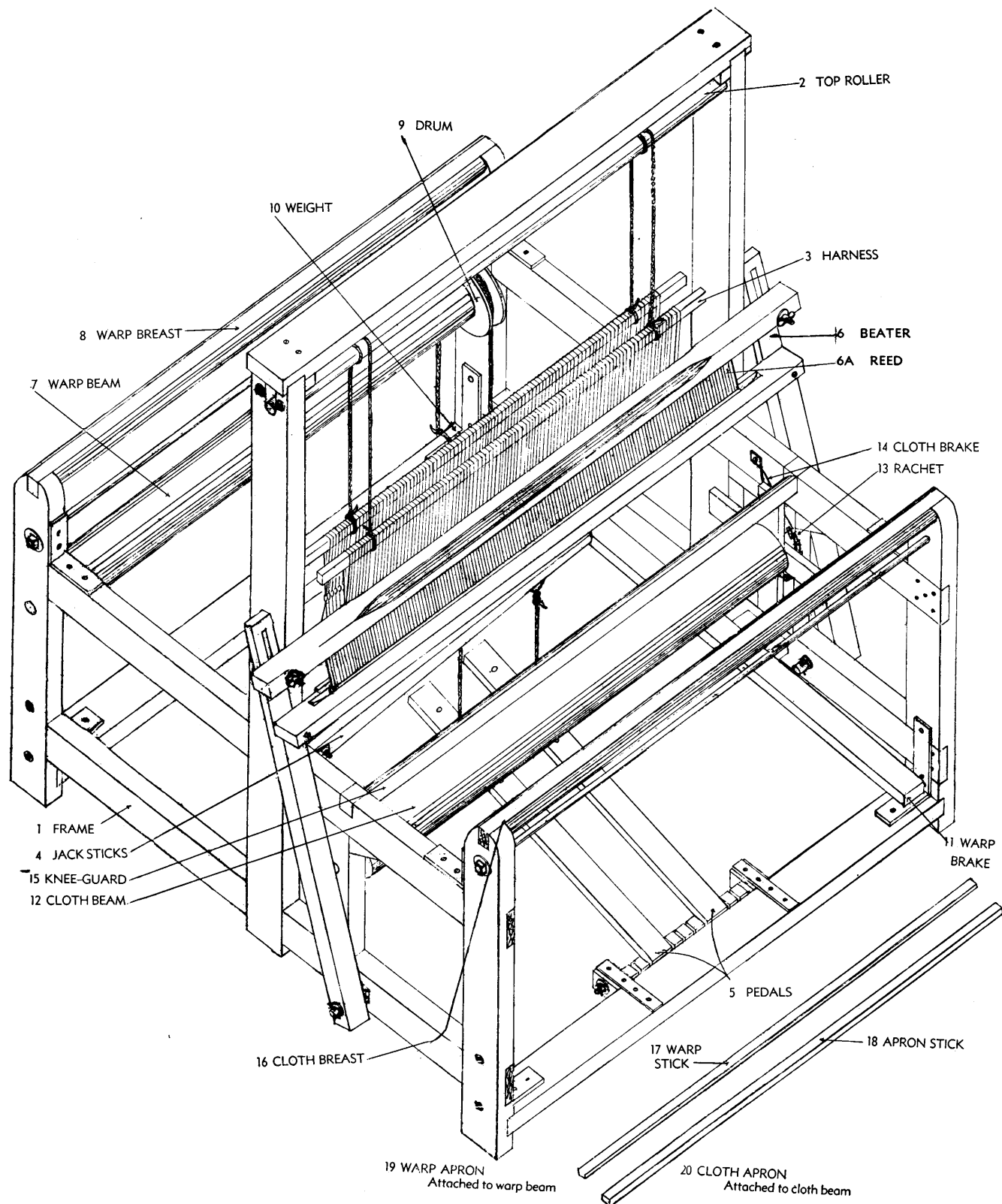

B. PARTS OF THE LOOM

1. **FRAME**—side pieces and cross bars of the loom.
2. **TOP ROLLER**—the roller just under the top bar. It rolls freely and helps to move the harnesses up and down easily.
3. **HARNESSES**—two are required for plain weaving. Each one is made up of several heddles hung between two sticks. The harnesses are used to raise and lower the warp threads.
 - A. **HEDDLE**—a string loop tied so that it has a small opening in the center called an eye through which the warp thread passes.
4. **JACK STICKS**—two small levers. One end of each is fastened to the inside of the frame and the other end is tied to a harness and to a pedal. The jack sticks keep the harnesses in balance while weaving.
5. **PEDALS**—two foot levers. One end of each is fastened to the front of the loom on the inside of the frame and the other end is tied to a jack stick. They are used to raise and lower the harness.
6. **BEATER**—a movable wooden frame that holds the reed.
- 6A. **REED**—a comb-like piece made of small metal strips which fits into the beater. Reeds may be obtained in different sizes and are interchangeable. The spaces between the strips are called dents. The reed has two uses: (1) To hold the warp threads at a given point. (2) To pull the filling threads into place.
7. **WARP BEAM**—the roller in the back of the loom on which the warp threads are wound. It has a drum on one end.
8. **WARP BREAST**—horizontal cross bar at the back of the loom over which the warp threads pass. This piece should be extremely smooth.
9. **DRUM**—the space on the end of the warp beam where the rope from the brake is wound.
10. **WEIGHT**—about an eight pound block of metal hung on the end of the warp brake.
11. **WARP BRAKE**—a lever attached to the inside of the frame and used to control the turning of the beam.
12. **CLOTH BEAM**—roller beneath the front part of the loom on which the woven cloth is rolled.
13. **RATCHET**—a metal disk with teeth. Placed on the end of the cloth beam to hold the cloth brake.
14. **CLOTH BRAKE**—a metal bar to control the turning of the cloth beam.
15. **KNEE-GUARD**—a horizontal bar above the cloth beam and over which the apron and woven material passes. This bar provides room for your knees while weaving. It should be very smooth.
16. **CLOTH BREAST**—horizontal cross bar in the front of the loom over which the woven cloth passes. This bar should be very smooth.
17. **WARP STICKS**—thin narrow sticks slightly shorter than the warp beam. At least 20 are needed in winding the warp on to the warp beam in order to keep it level and smooth.
18. **APRON STICKS**—two small strong sticks used in the hems of the two aprons. The ends of the warp are tied to these sticks.
19. **WARP APRON**—a heavy cloth fastened to the warp beam and reaching to within a few inches of the back harness.
20. **CLOTH APRON**—a heavy cloth fastened to the cloth beam and reaching to within a few inches of the reed.

PARTS OF THE LOOM

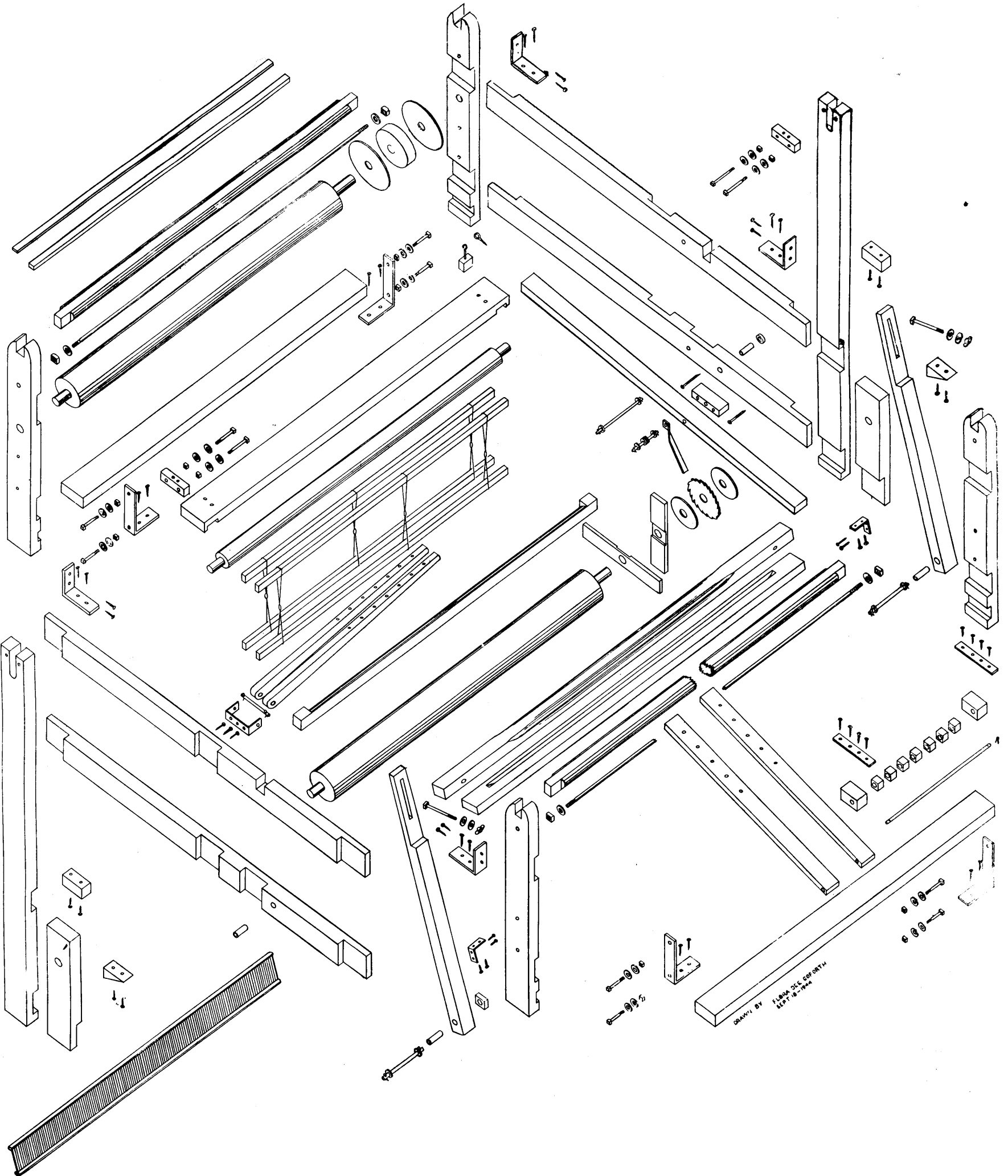

C. PUTTING THE LOOM TOGETHER

The sidepieces are fastened together with permanent joints. The center bars and rollers and the beater are all removable so that the loom can be easily taken down and moved from one room or building to another.

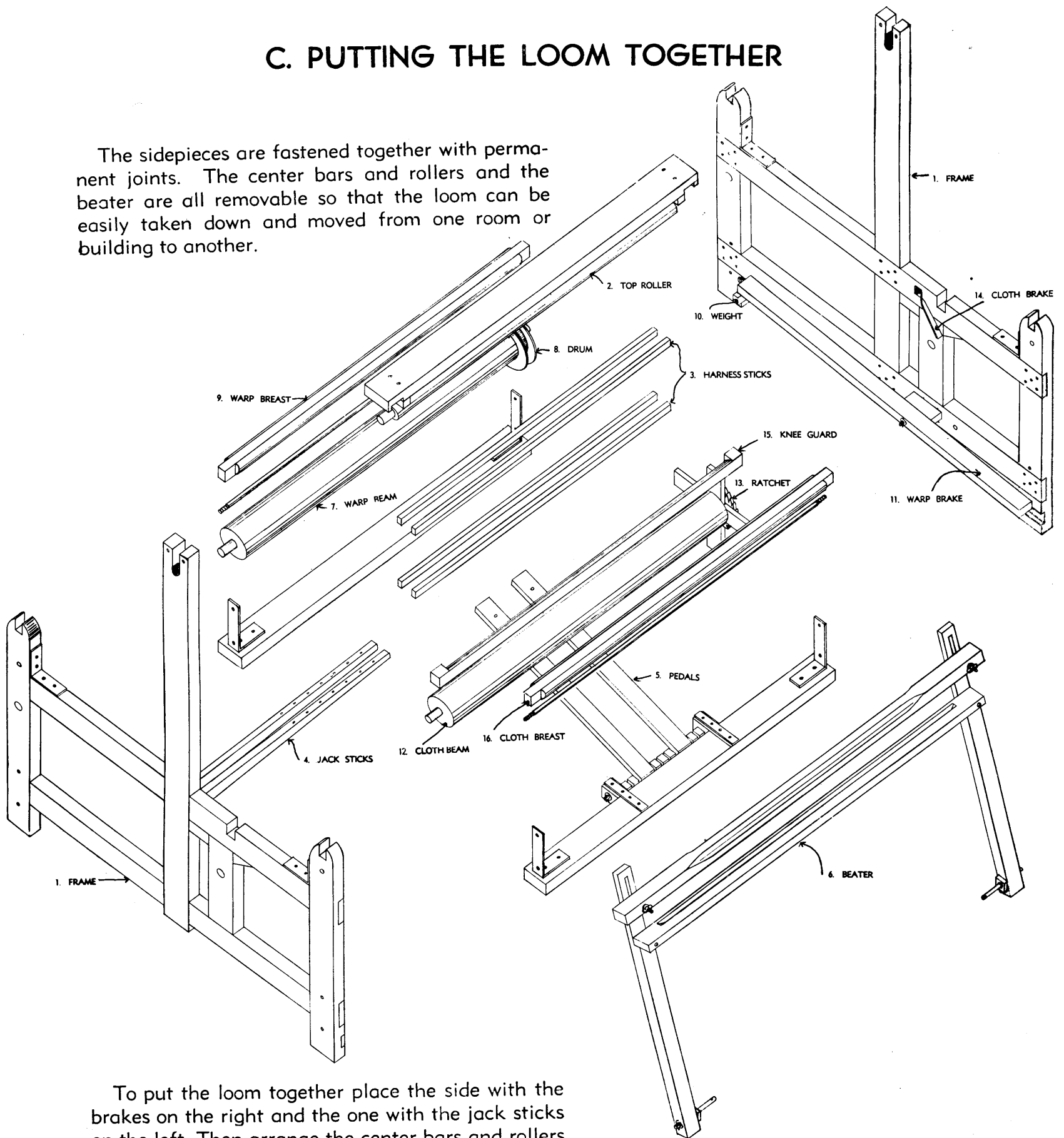

To put the loom together place the side with the brakes on the right and the one with the jack sticks on the left. Then arrange the center bars and rollers in their correct places by fastening or bolting one end of each to one side piece. After this has been done slip the other side into place and fasten it. Next place the beater over the side pieces and fasten it in place. All bolts and screws should be tight so that the loom will be firm and rigid at all times.

D. REEL

REEL—used to measure and wind the warp. One bar has small holes drilled on the top side $\frac{1}{2}$ inch apart. This serves as a measuring stick when winding the warp and is called the "first bar."

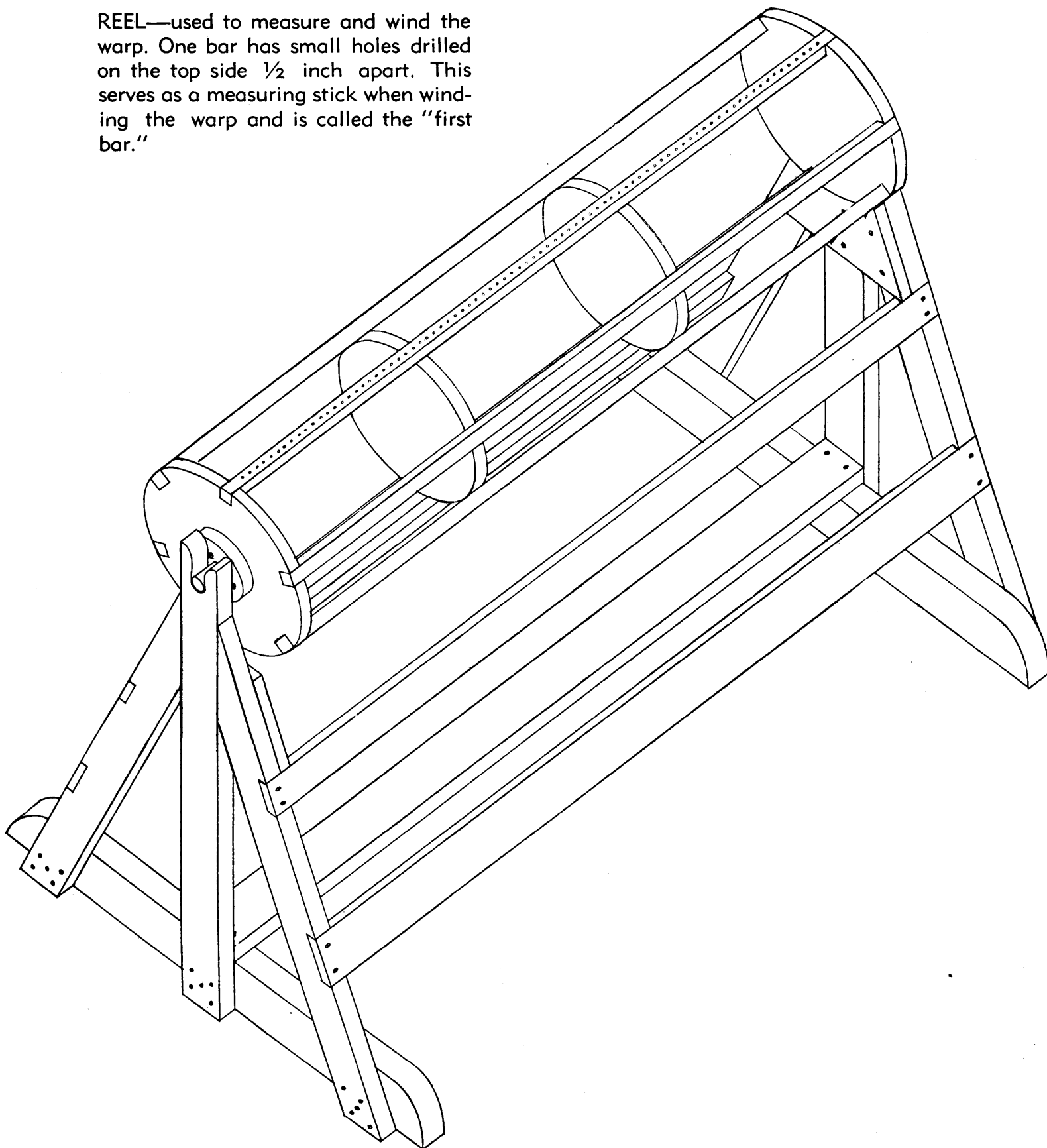

"EXPLODED" VIEW OF REEL

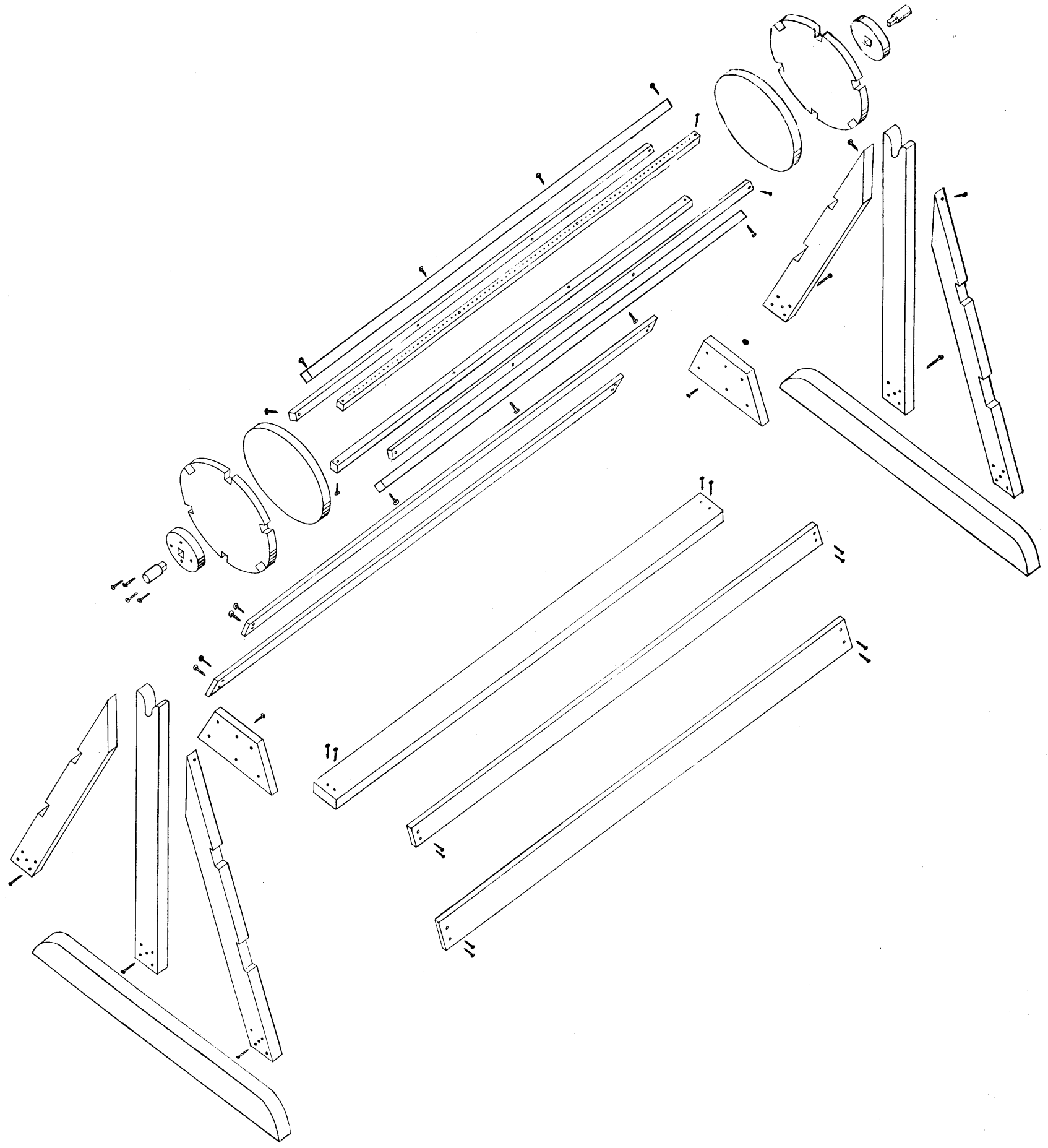

E. SKEIN SPREADER

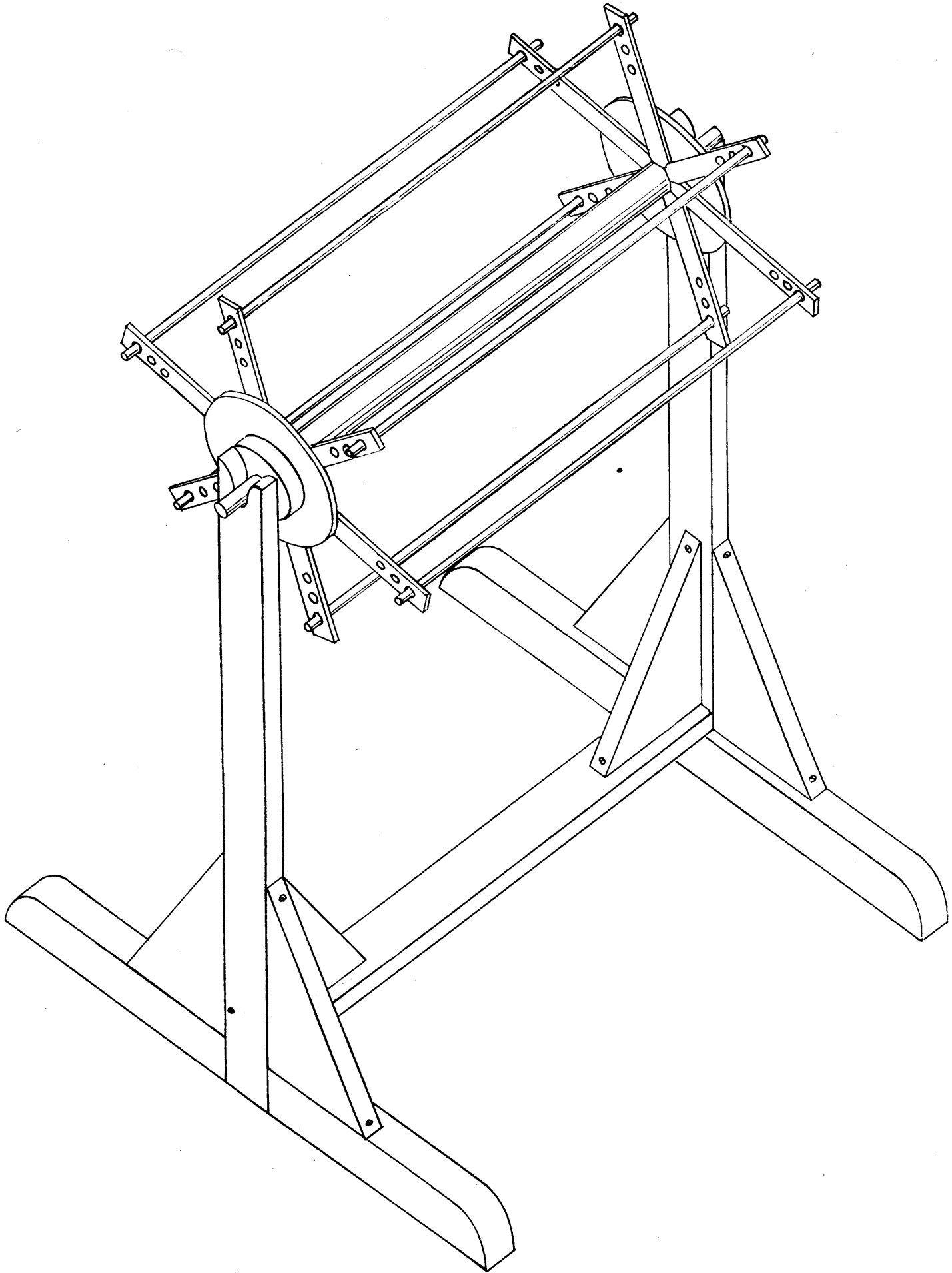

SKEIN SPREADER— used to hold the skeins or spools while the warp is being wound.

PARTS OF THE SKEIN SPREADER

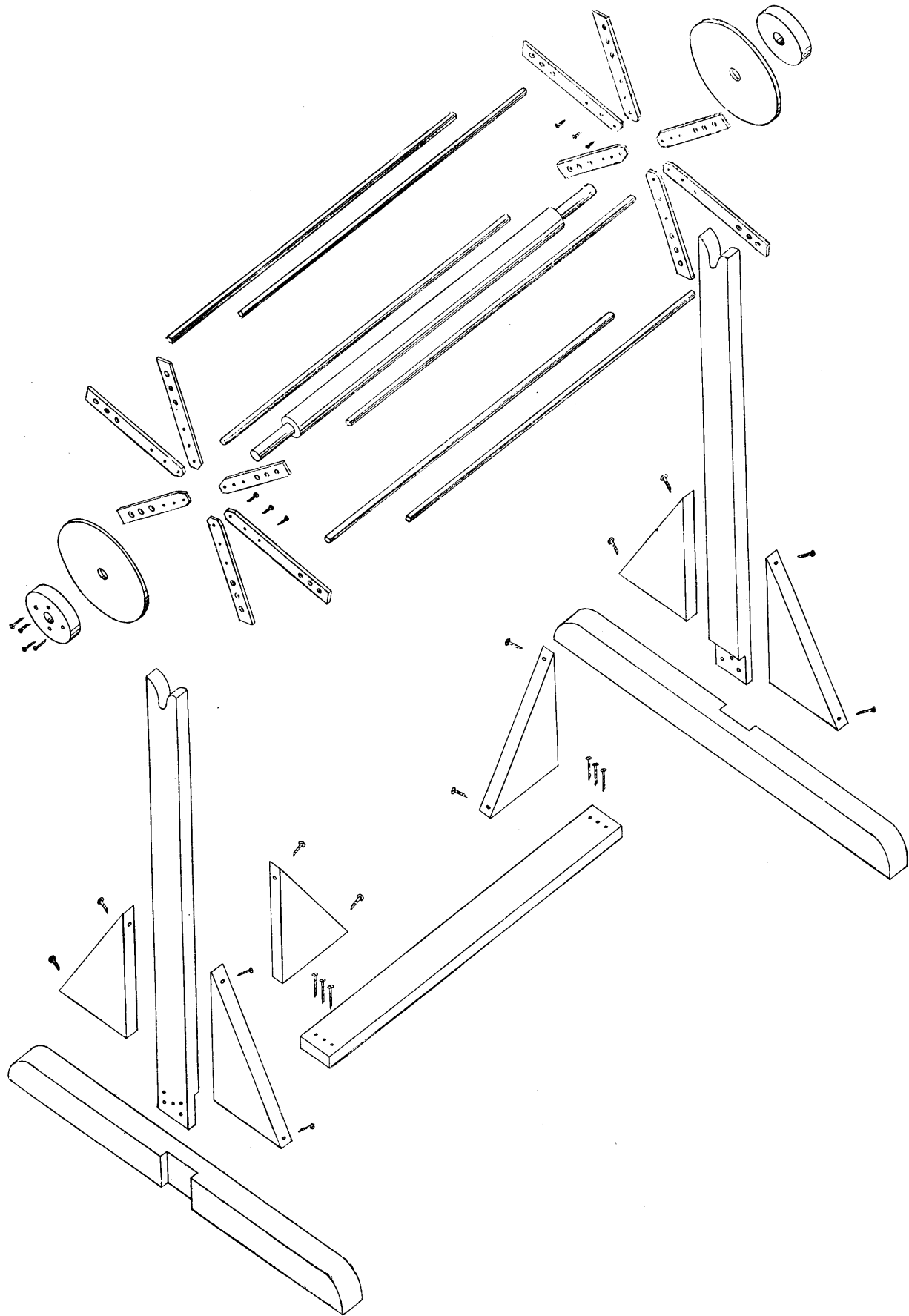

F. HEDDLE BOARD

The Heddle board is used for tying the heddles. Mark one end with an X.

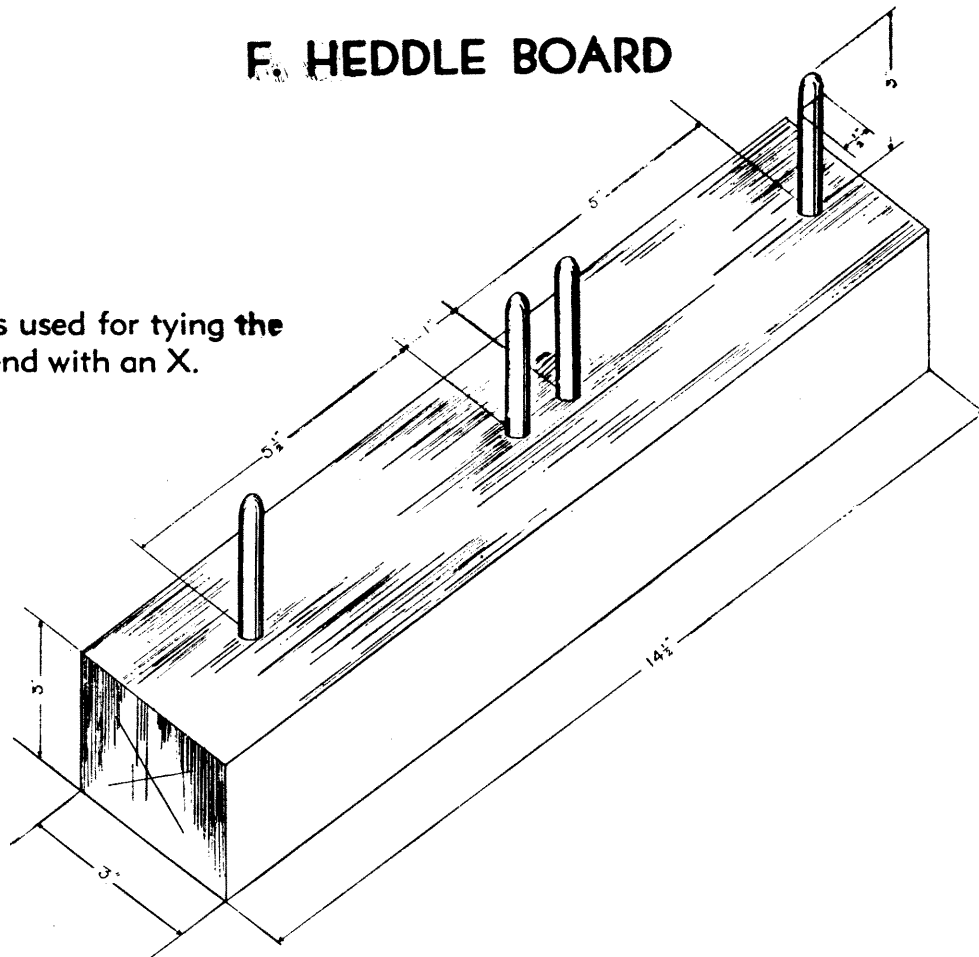

G. BOBBIN WINDER

Get a small grinder that uses a 5 inch, or larger, emery wheel and that is geared to a high speed. Remove the emery wheel and weld on a 6-inch spindle made of a 3/8-inch rod that has a long dull point on one end.

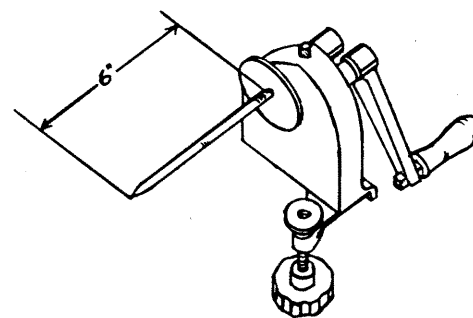
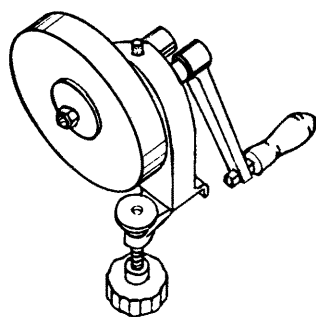

H. SHUTTLES

SHUTTLES—used to carry the filling thread.

Flat shuttle for fine or medium yarns.

Boat shuttle for very fine yarns.

Rug shuttle for rag stripes and heavy yarns.

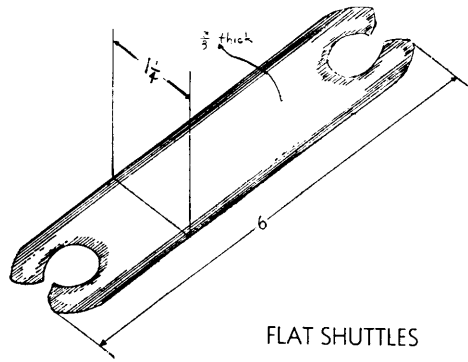

FLAT SHUTTLES

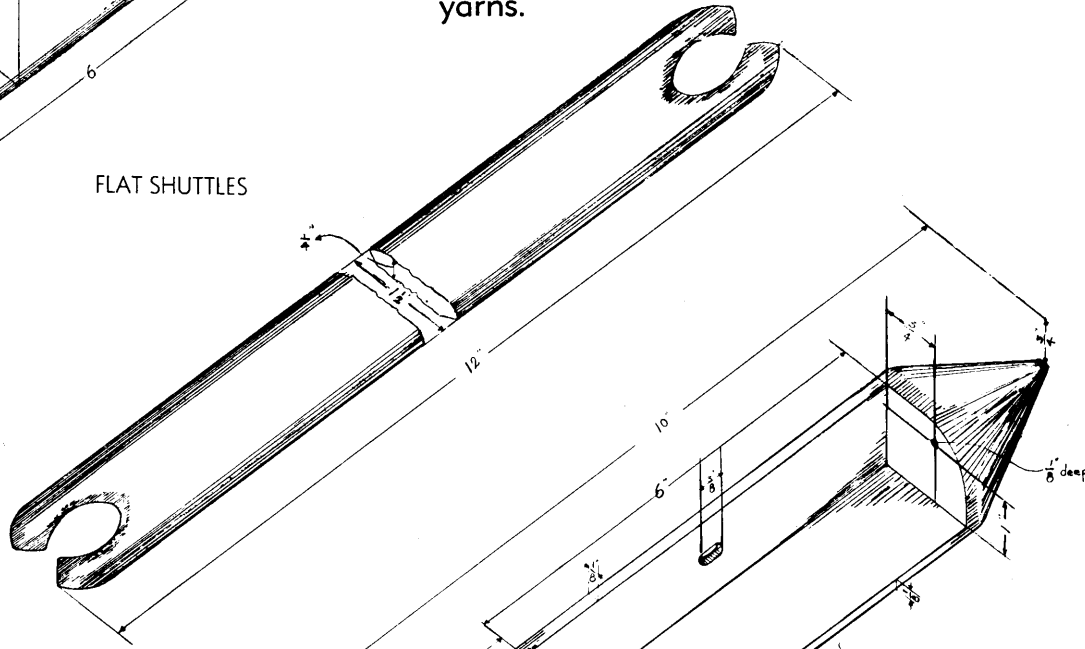

BOAT SHUTTLES

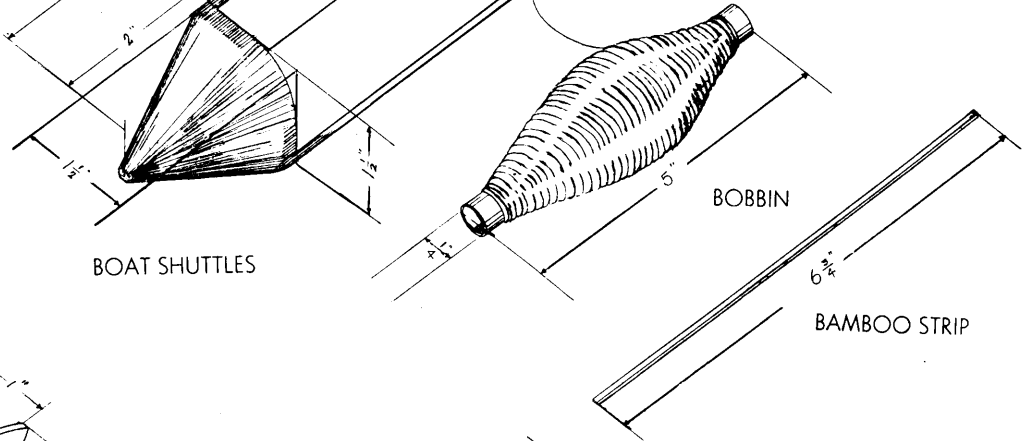

BOBBIN

BAMBOO STRIP

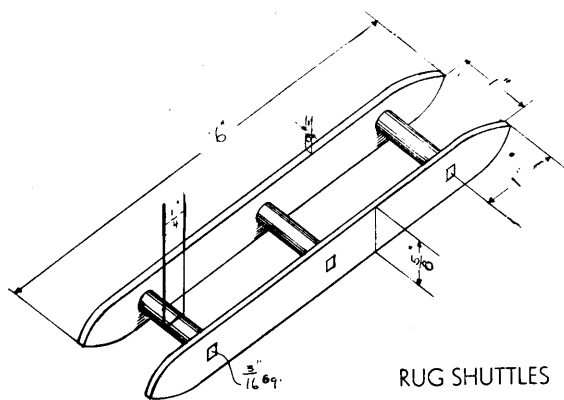

RUG SHUTTLES

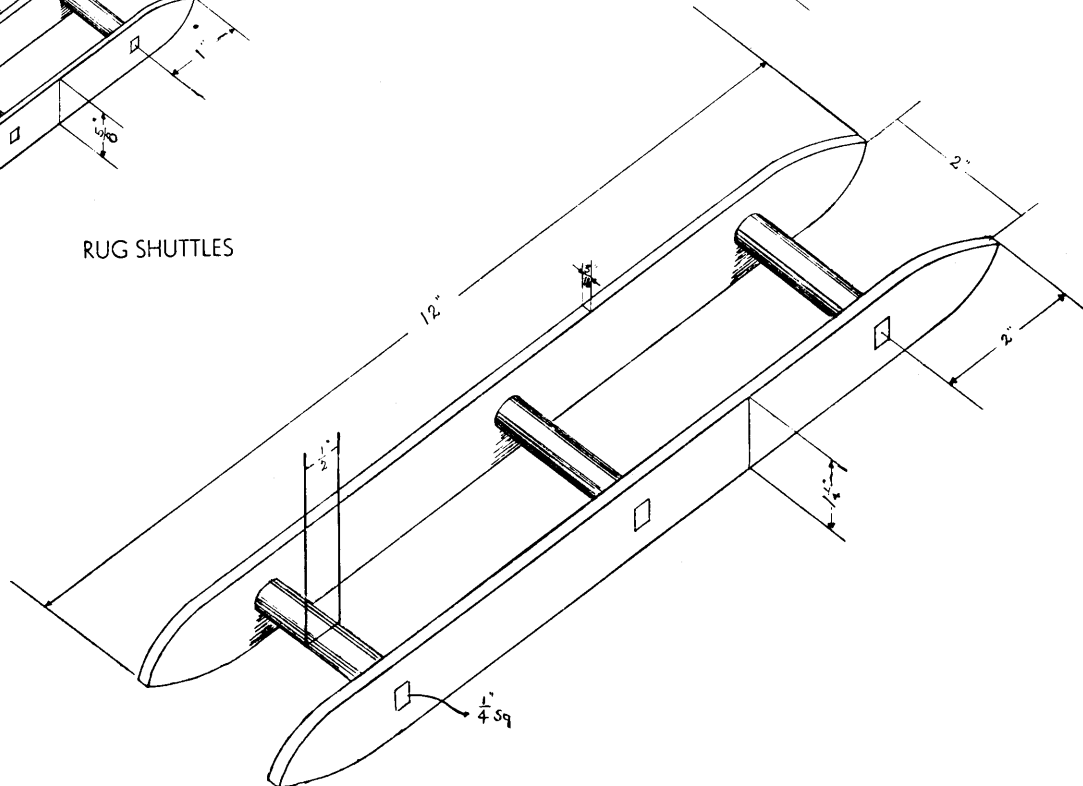

I. BENCH

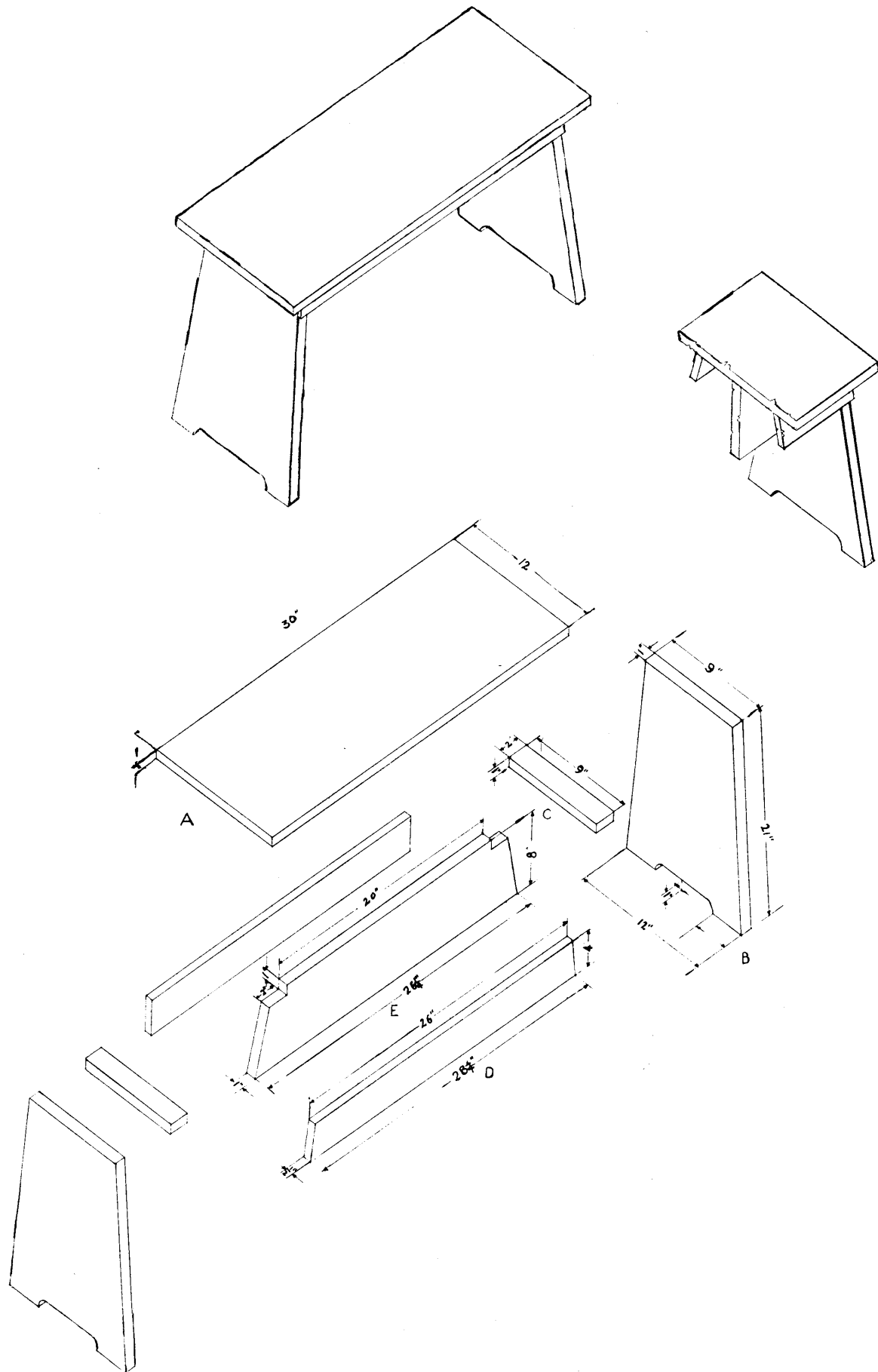

2. GETTING THE LOOM READY TO WEAVE

A. MAKING THE HARNESS



The heddles should be made of medium size hard twisted twine. Carpet warp can be used but it does not last as long as a hard twisted twine.

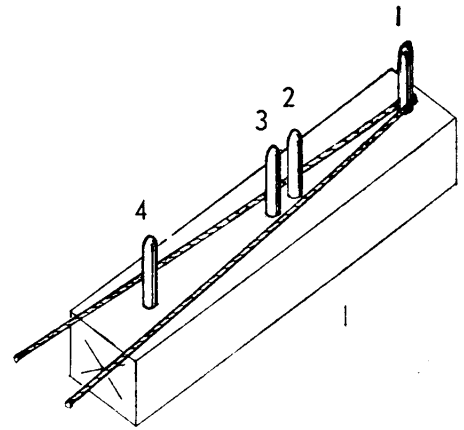

Place the heddle board on a table with the end marked X towards you. Place the twine around the first peg, measure, and cut it a little longer than the heddle board.

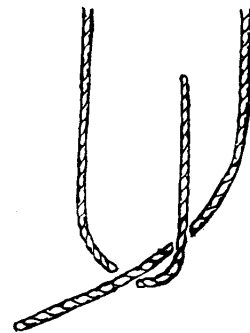
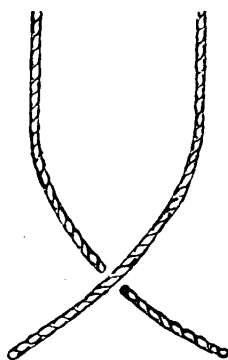
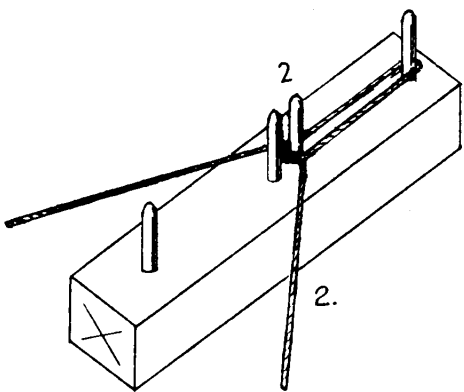

Tie a simple knot in front of the second peg by crossing the right end over the left one and twisting or wrapping the two.

Pull both ends firmly until the knot is tight against the peg.

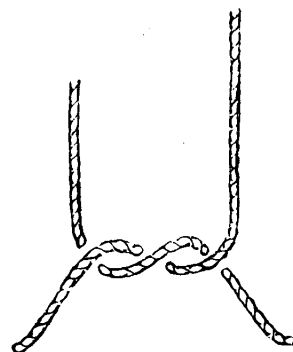

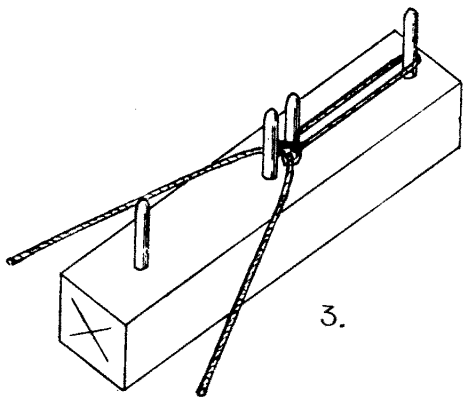

Tie a second knot in the same place.

This time cross the left end over the right one (1) and fold under (2). Again pull both ends until the knot is tight and firm (3 and 4). These two knots make a square knot that will not slip.

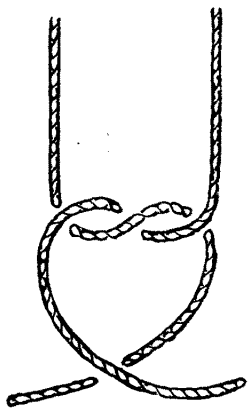

1

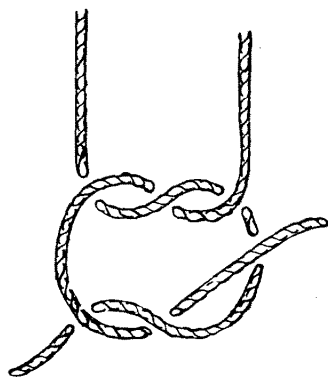

2

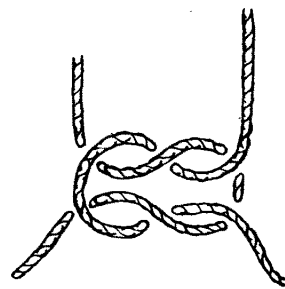

3

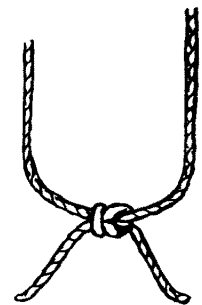

4

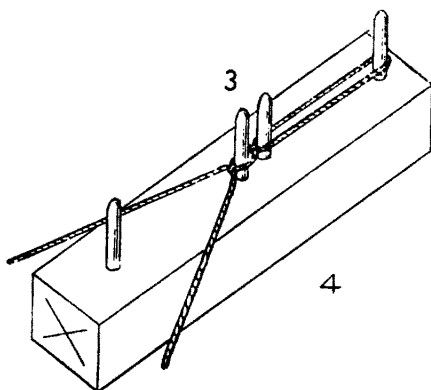

Tie another square knot in front of the third peg.

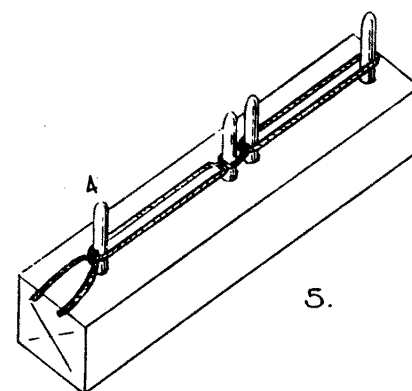

Tie another square knot in front of the fourth peg. This completes one heddle.

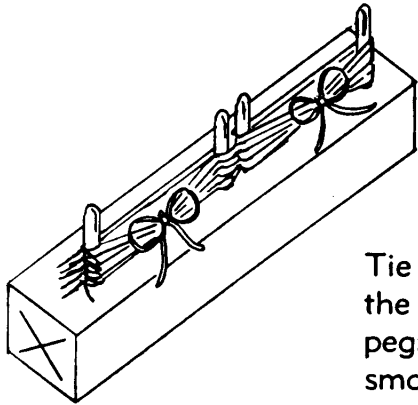

Tie about 10 heddles on the board. Tie the group of heddles together between pegs 1 and 2 and between 3 and 4 using small bow knots.



Carefully pull or slip the group off the pegs.

The tied places keep the heddles from becoming tangled. Continue tying heddles in groups of 10 until you have from 200 to 400 heddles.

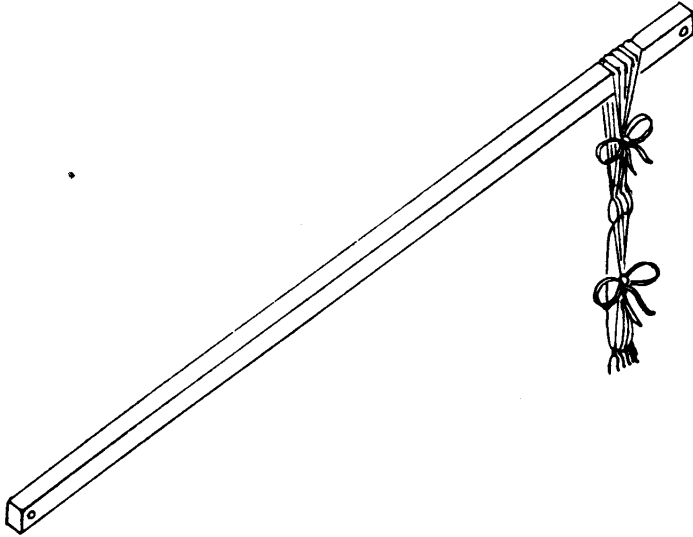

Place 100 to 200 heddles on one of the harness sticks by slipping the stick through the top part of each group. Tie a string from one end of the stick to the other end over the heddles. This string serves as a guard to keep the heddles from slipping off if the harness is dropped.

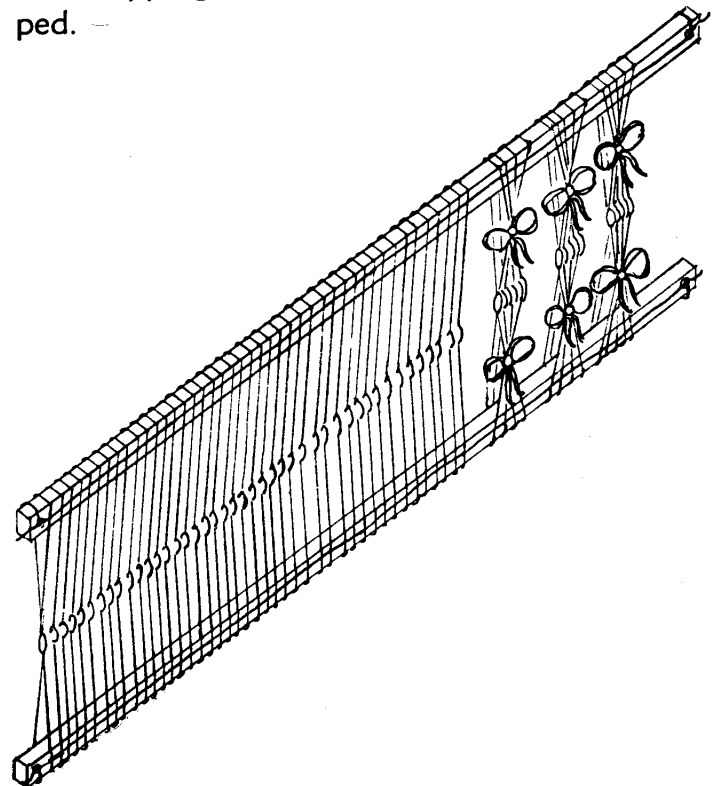

Slip another harness stick through the bottom part of each group of the heddles. Be careful that you do not twist a group as it is placed on the bottom stick. Tie a guard string on the bottom stick. Untie the groups of heddles and spread them evenly along the two sticks. This completes one harness. You will need two harnesses for simple weaving.

B. TYING UP THE LOOM (I)

Wrap two heavy cords around the top roller and tie one end of each to the front harness and the other ends to the back harness. The harnesses should be level and tied high enough to lift a string about $\frac{1}{2}$ " to 1" that has been threaded through the eye of a heddle on each harness and through the reed and stretched from the warp breast to the cloth breast.

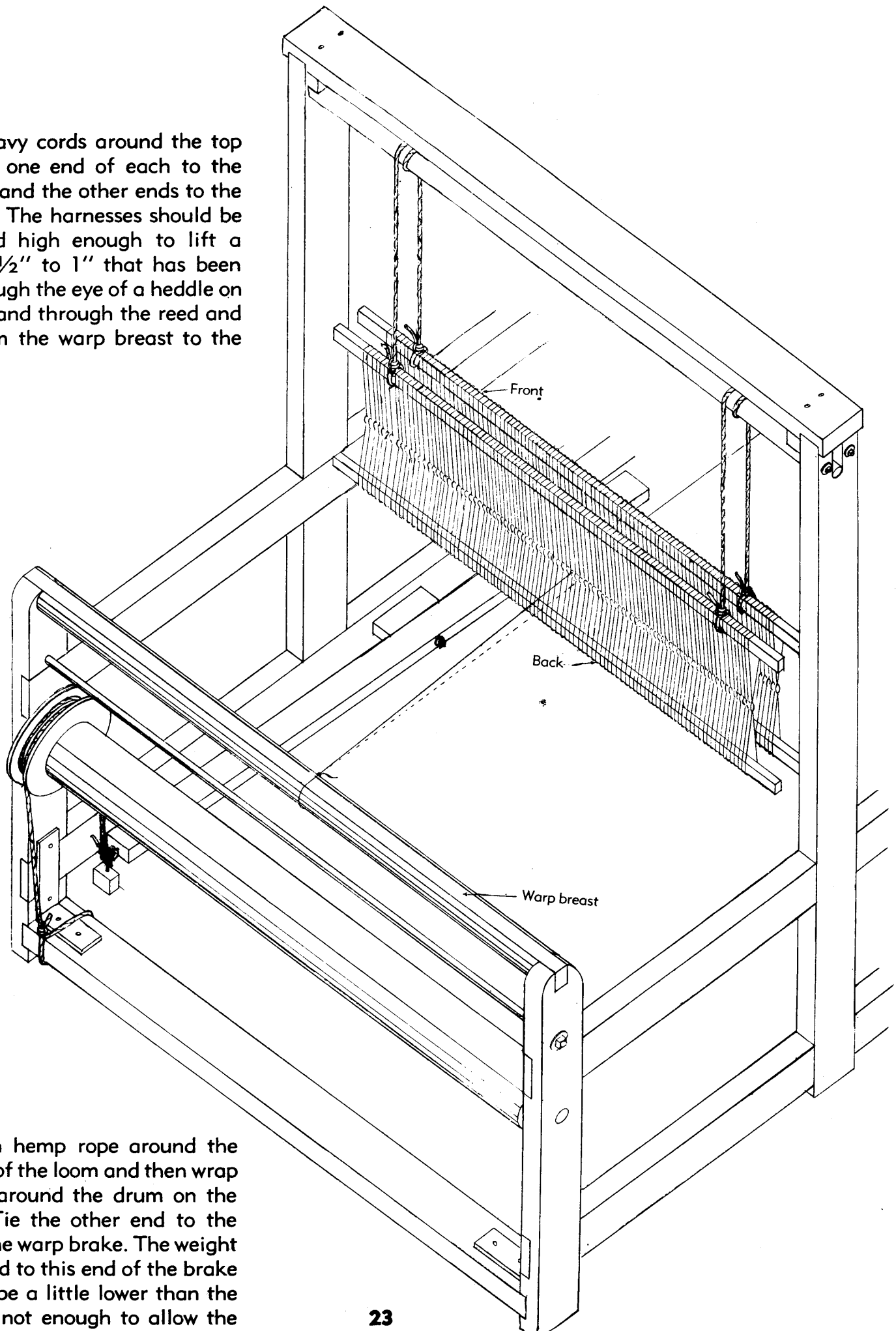

Tie a $\frac{1}{4}$ inch hemp rope around the bottom board of the loom and then wrap it completely around the drum on the warp beam. Tie the other end to the screw eye on the warp brake. The weight is also attached to this end of the brake which should be a little lower than the front end but not enough to allow the

Details of tying the harness

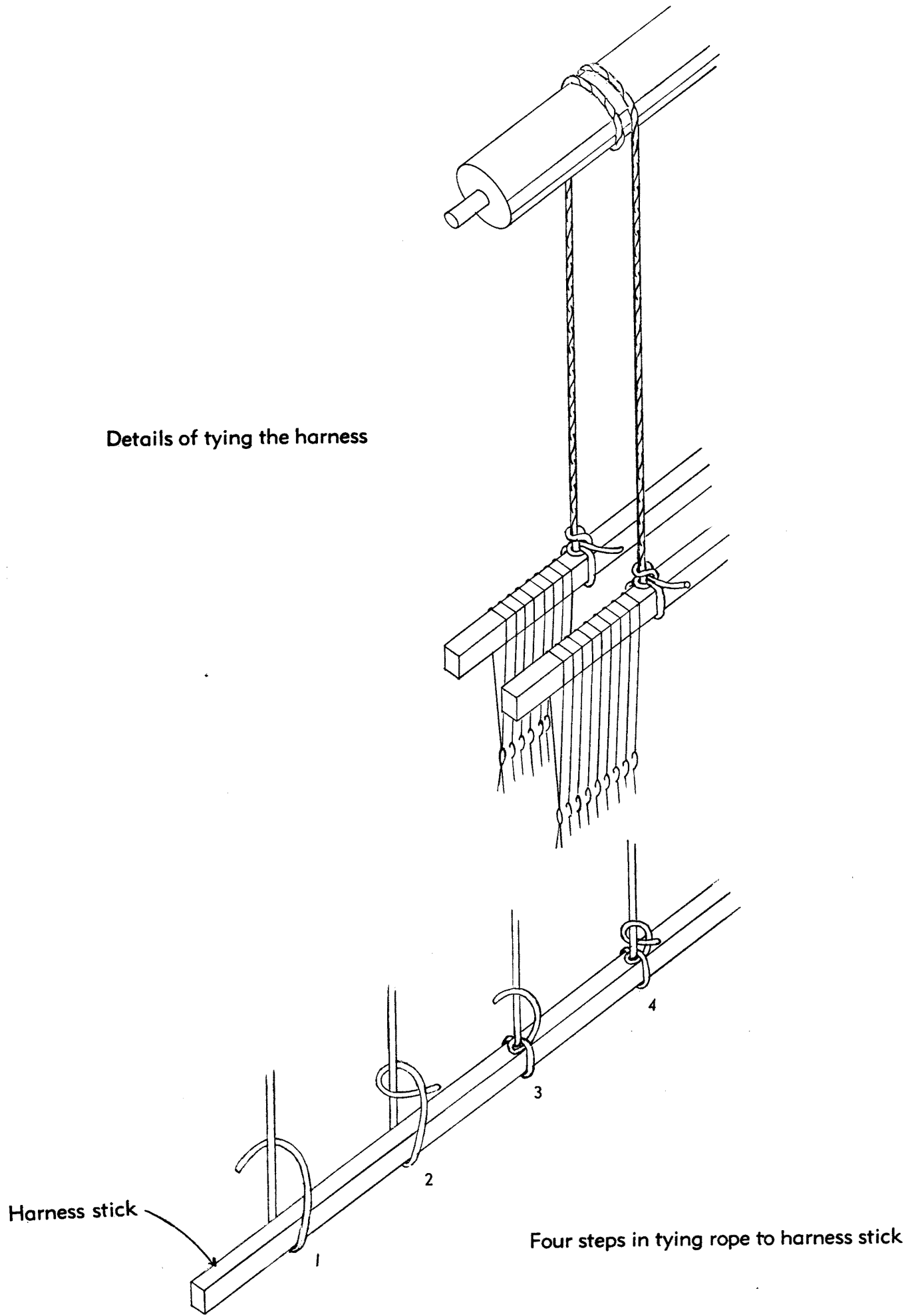

B. TYING UP THE LOOM (2)

Tie the front jack stick to the front harness and the back jack stick to the back harness. Place these ties in the middle of the bottom harness sticks. The jack sticks should be even with the loose ends 2 or 3 inches higher than the ends that are fastened to the loom.

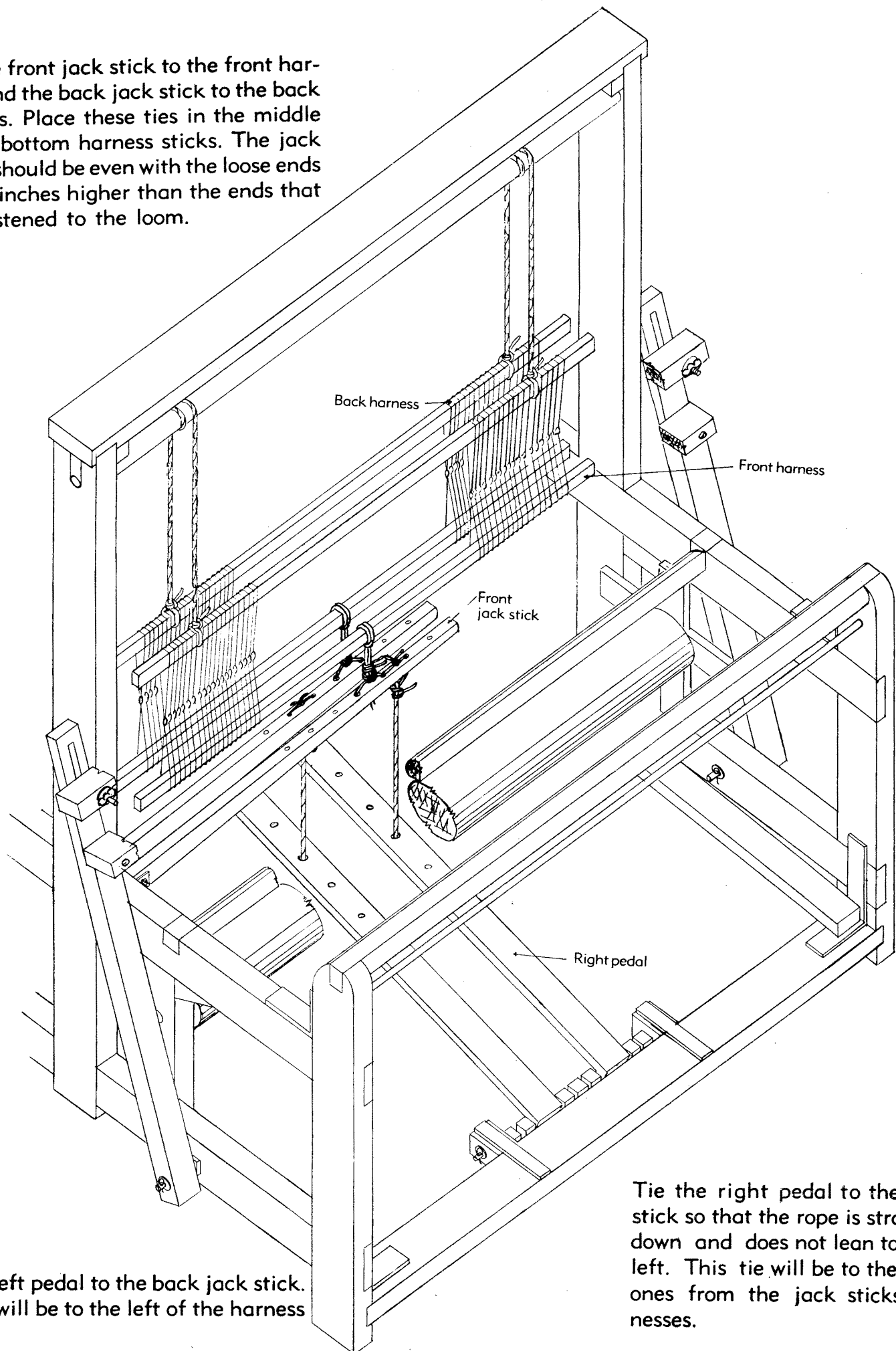

Tie the left pedal to the back jack stick. This tie will be to the left of the harness ties.

Tie the right pedal to the front jack stick so that the rope is straight up and down and does not lean to the right or left. This tie will be to the right of the ones from the jack sticks to the harnesses.

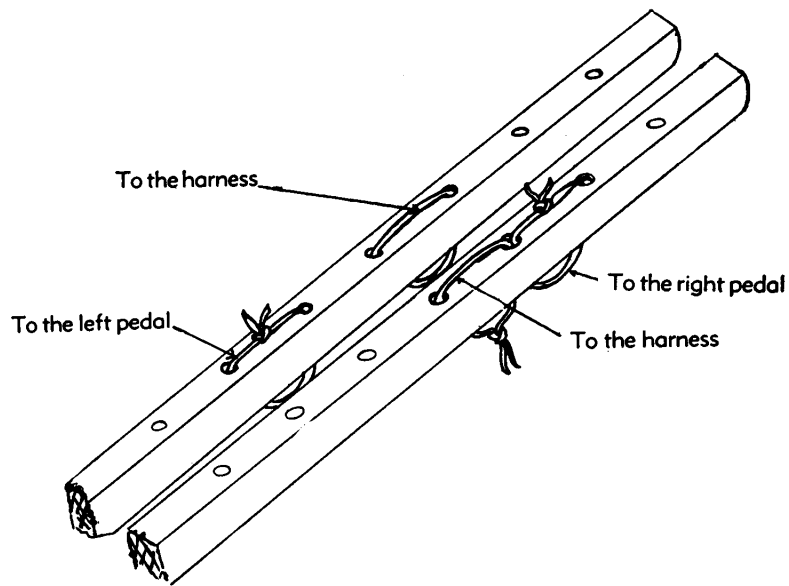

It will be easier to adjust the loom if you will tie 2 small loops in each jack stick at the correct places for the harness and the pedal ties.

It is necessary to re-adjust the cords from the harnesses to the pedals each time that a new warp is set up. These ties should be made with knots that will hold securely but at the same time are easy to untie.

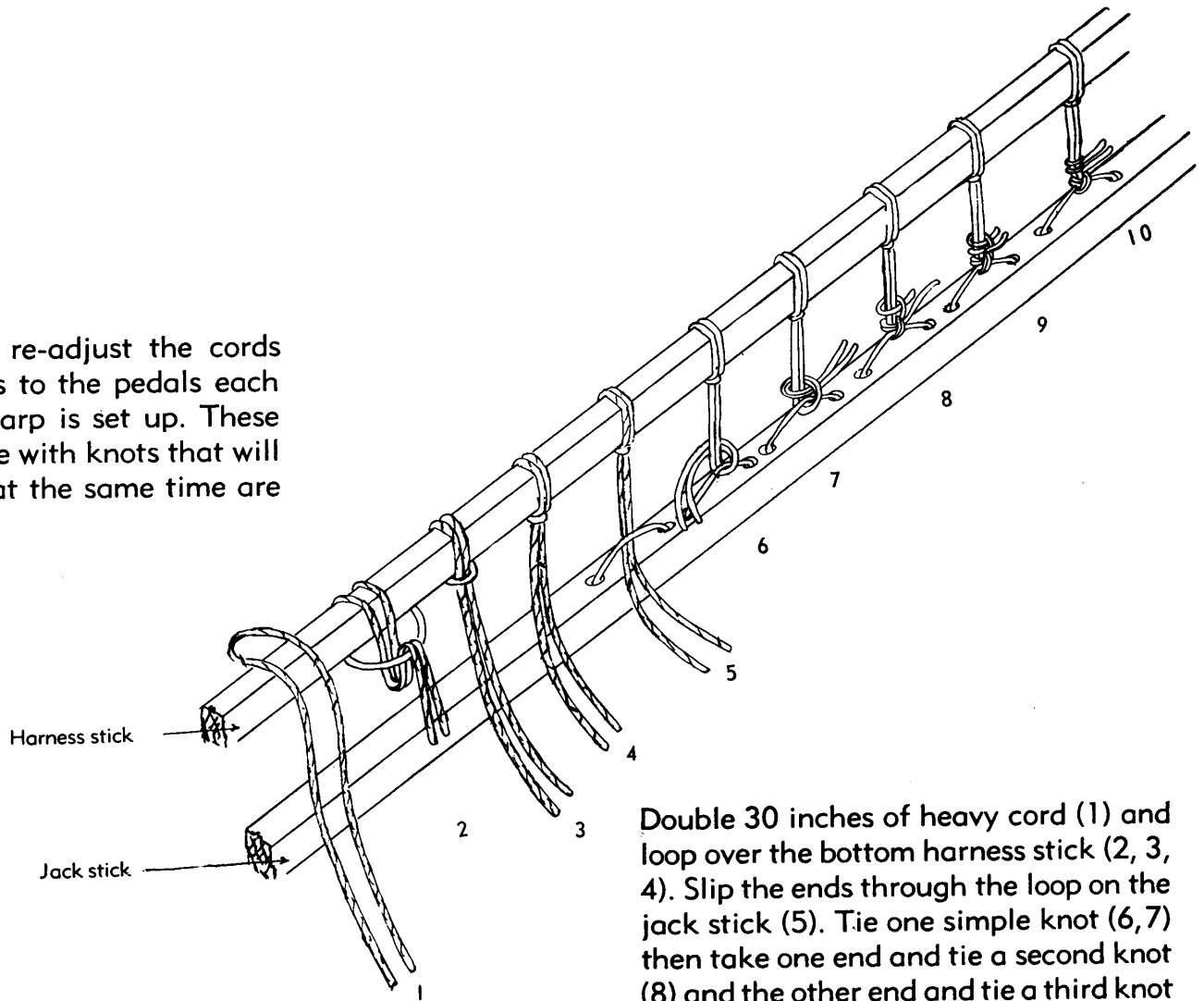

Double 30 inches of heavy cord (1) and loop over the bottom harness stick (2, 3, 4). Slip the ends through the loop on the jack stick (5). Tie one simple knot (6,7) then take one end and tie a second knot (8) and the other end and tie a third knot (9). Pull both ends firmly (10).

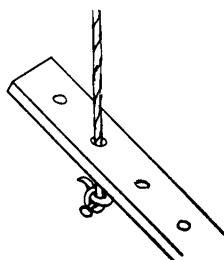

Place a nail through the knot underneath the pedal to keep it from pulling through the hole. The loose ends of the pedals should be 9 or 10 inches above the floor or high enough so that they will not strike the floor when pressed down.

Heavy blue denim 29 inches wide is satisfactory for making the aprons. Cut 2 pieces 38½ inches long. Take 4 inches off the width of one piece.

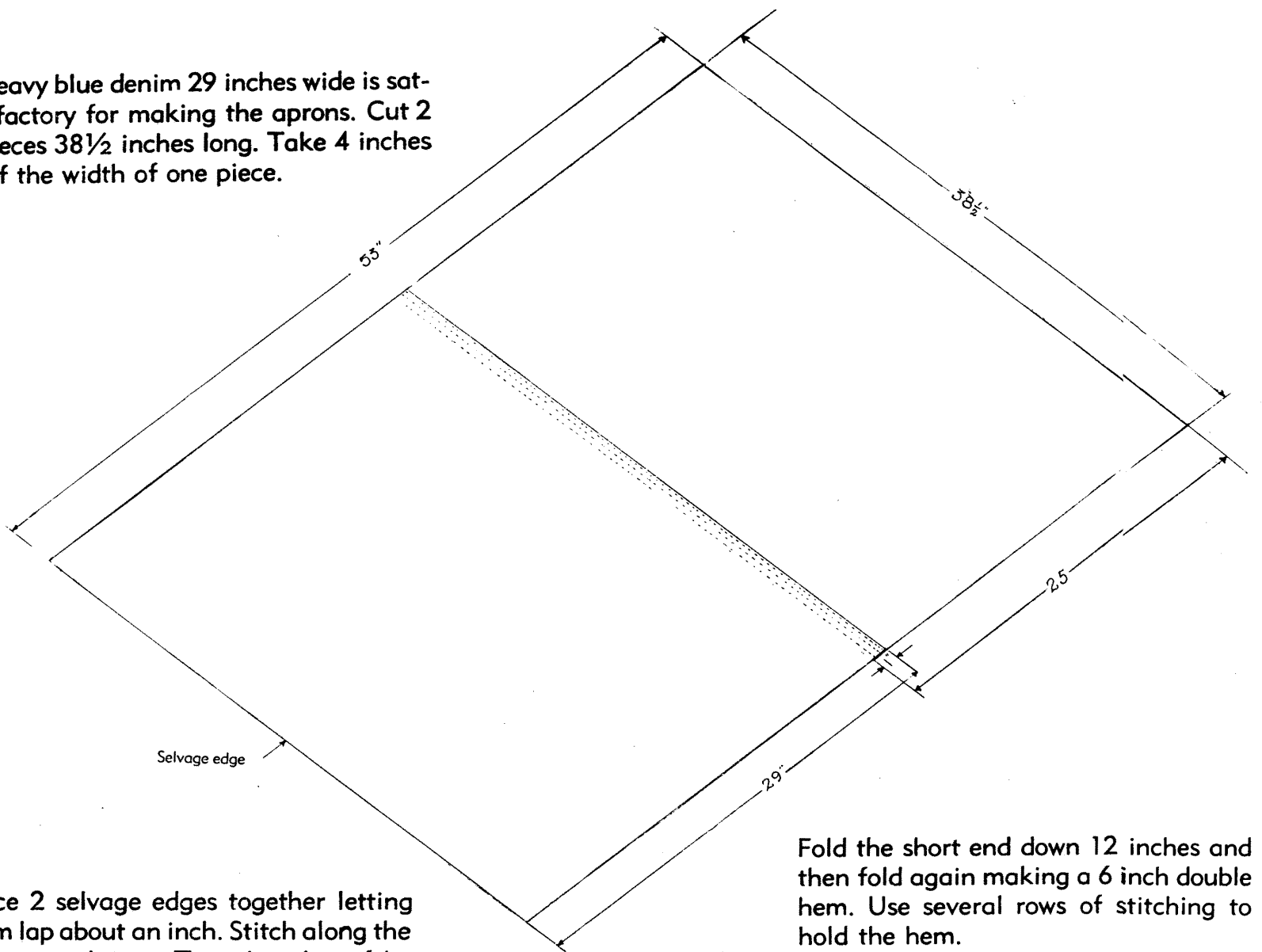

Place 2 selvage edges together letting them lap about an inch. Stitch along the edge several times. Turn the edges of the apron under ¼ inch and stitch.

Fold the short end down 12 inches and then fold again making a 6 inch double hem. Use several rows of stitching to hold the hem.

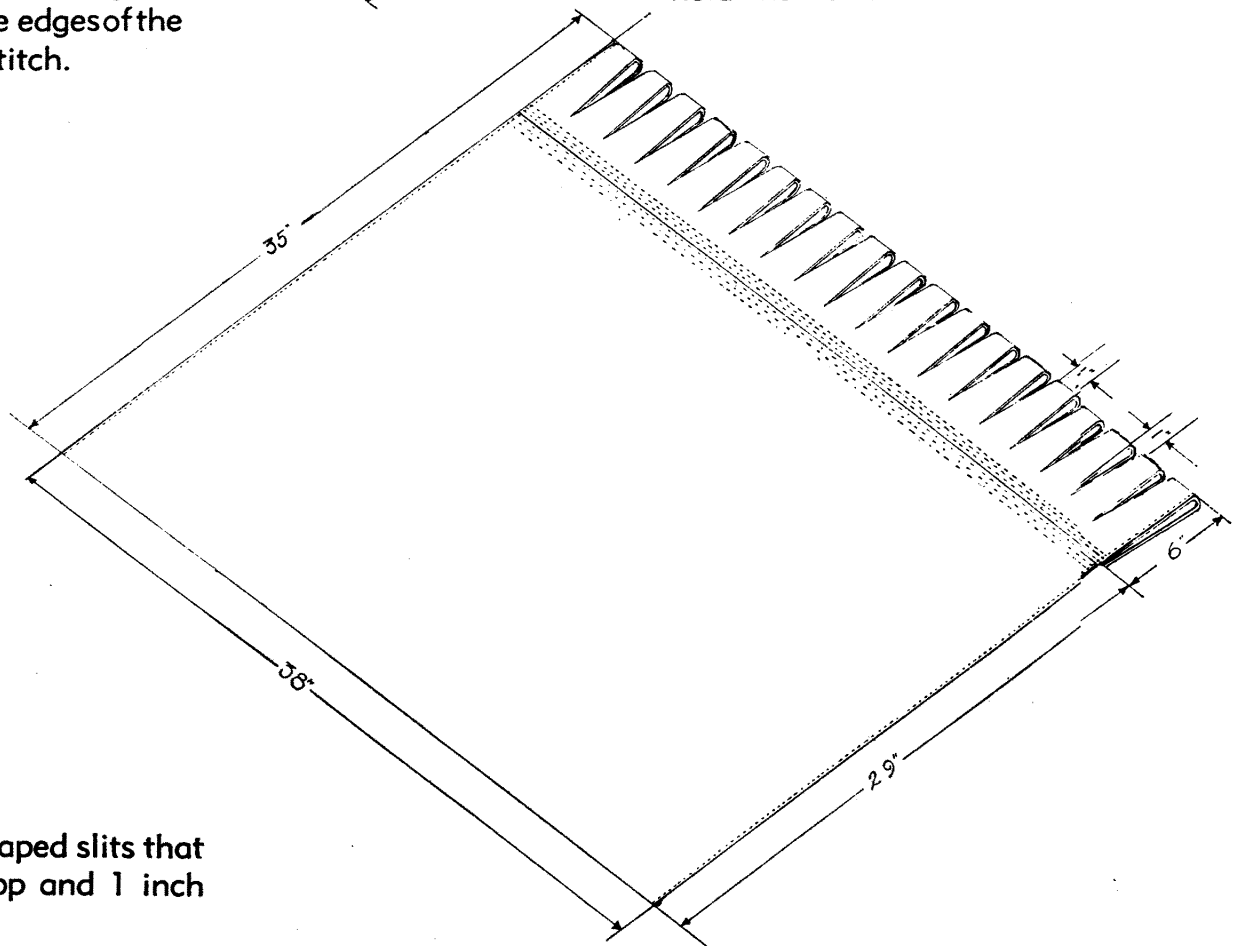

In the hem, cut long V-shaped slits that are 1 inch wide at the top and 1 inch apart.

ATTACHING THE WARP APRON

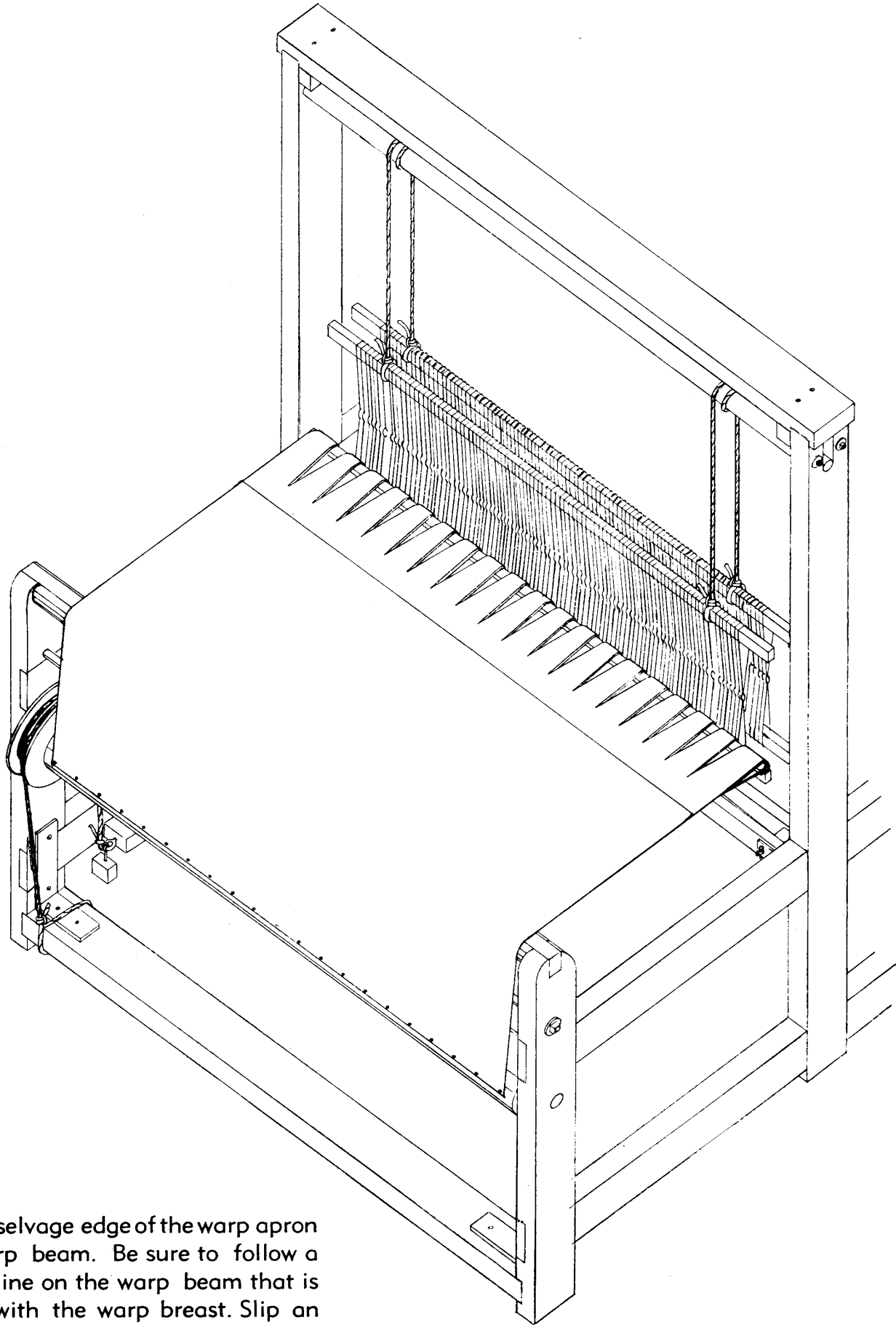

Tack the selvage edge of the warp apron to the warp beam. Be sure to follow a straight line on the warp beam that is parallel with the warp breast. Slip an apron stick through the hem of the apron. The stick should reach to within a few inches of the harness.

D. MAKING THE CLOTH APRON

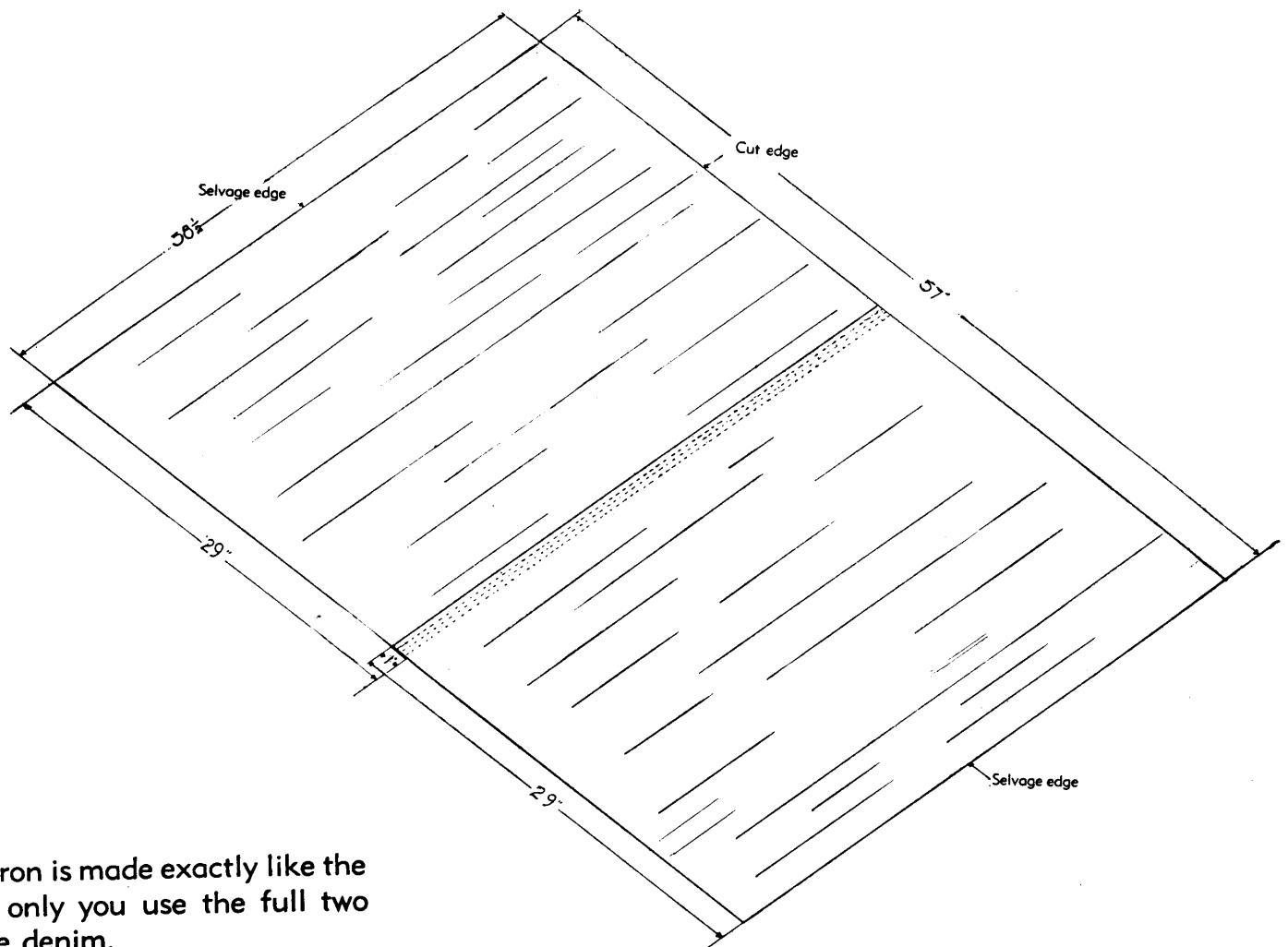

The cloth apron is made exactly like the warp apron only you use the full two widths of the denim.

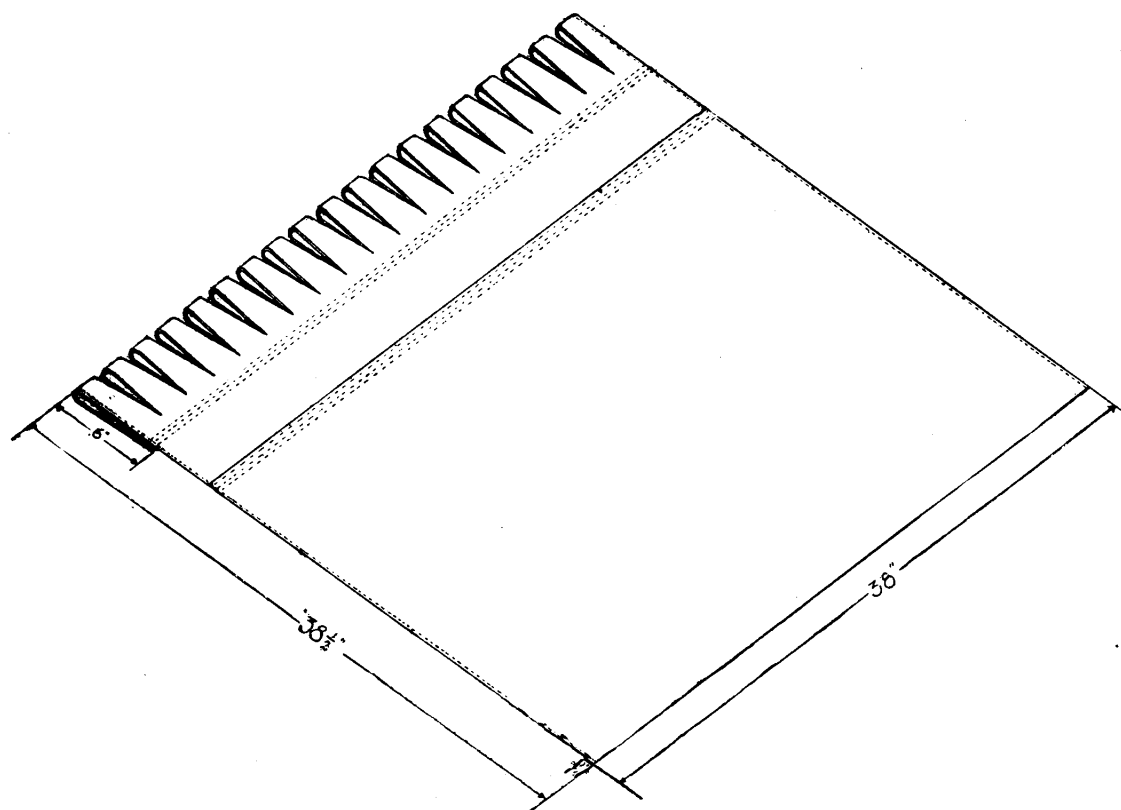

ATTACHING THE CLOTH APRON

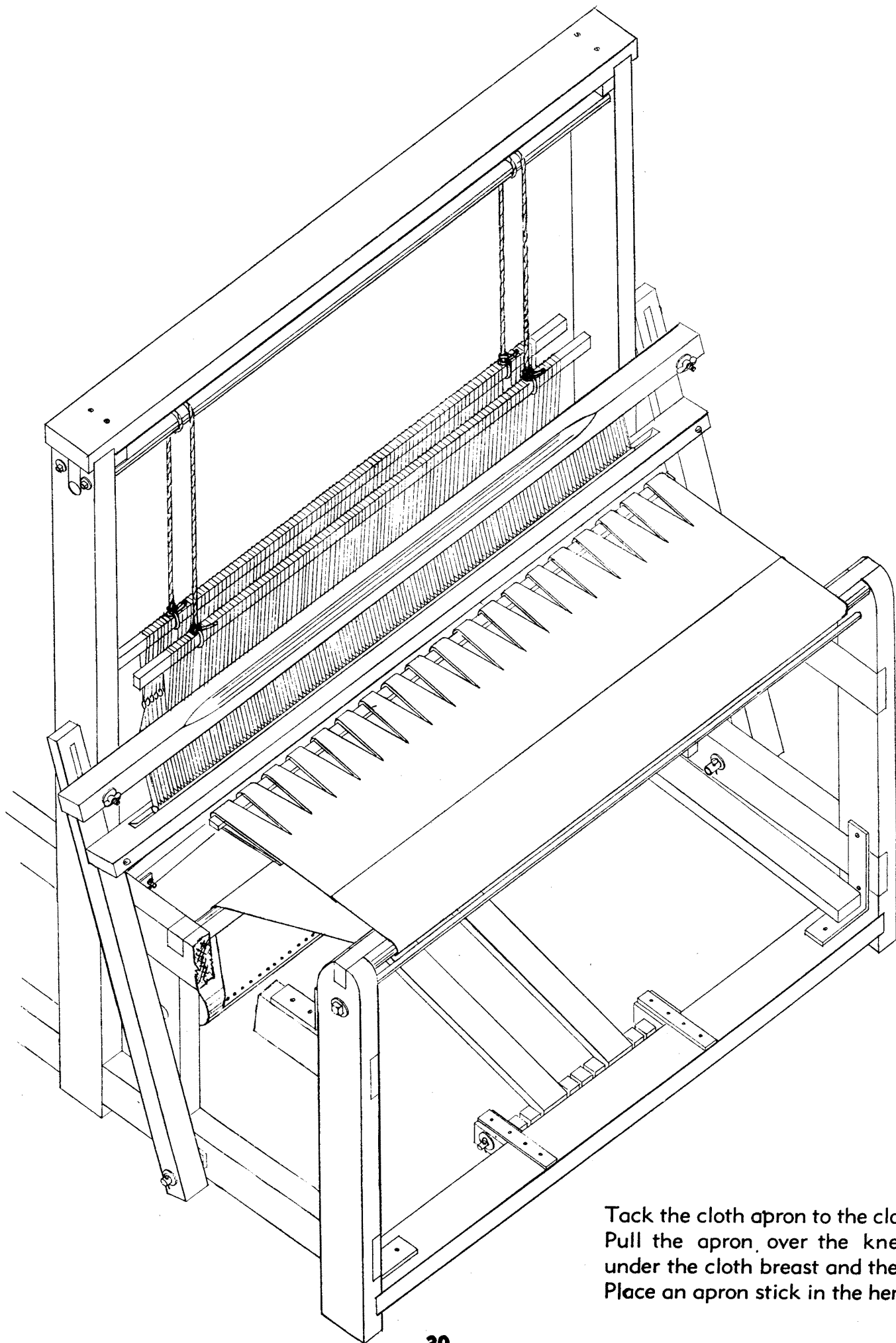

Tack the cloth apron to the cloth beam. Pull the apron over the knee-guard, under the cloth breast and then over it. Place an apron stick in the hem.

3. PLANNING AND WINDING THE WARP

A. PLANNING A SMALL PIECE

First select the material which you will use in weaving your first piece. Then plan the width and length of the piece or pieces you want to make. Small table mats made of carpet warp and strips of sewing scraps or old clothes are simple to make and at the same time are attractive. After you have selected the sizes of your finished pieces, figure the length and width of the warp you will need. All of the pieces made on one warp will have to be the same width.

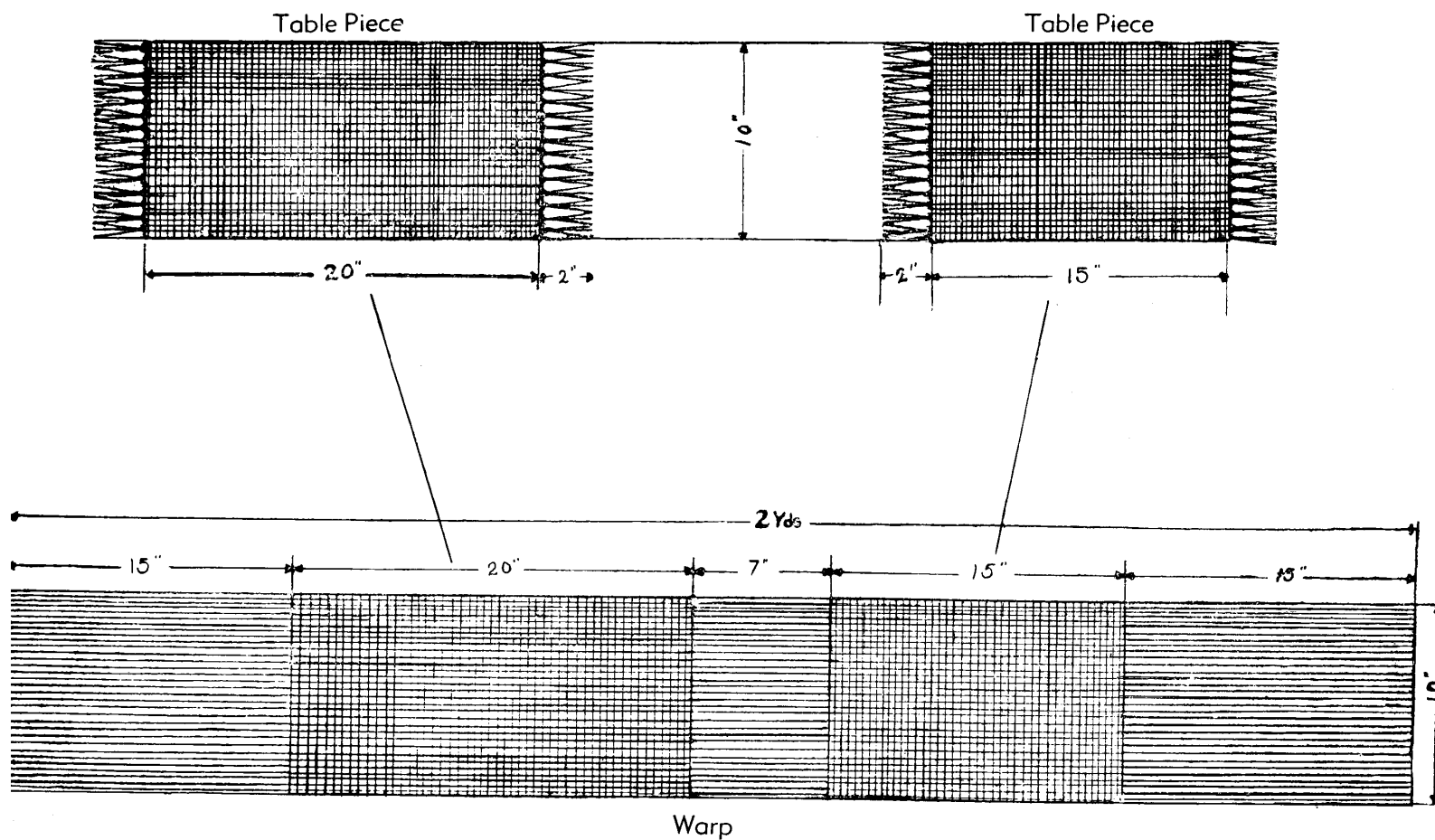

Make your warp the same width or a little wider than you want the finished piece. If you are making 2, 3 or more table pieces, add the lengths of each together, plus 5 to 7 inches between each piece for the fringe, plus 12 to 15 inches on either end for tying in the warp.

Our loom is equipped with a number 12 reed which is suitable for weaving a number of different things. The space between the little metal bars is called a dent. The number of dents per inch is the number of the reed. A number 12 reed has 12 dents per inch and is written 12's. The number is usually stamped on the end of the reed. These reeds are made in various sizes and are interchangeable in the loom.

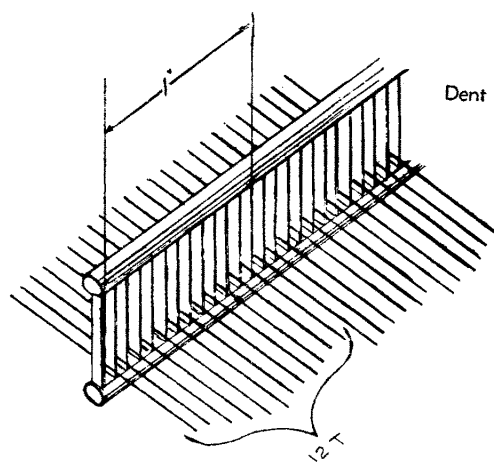

If you are using carpet warp, 8 to 12 threads per inch will be satisfactory. The example we are using has 12 threads. Multiply the width of the warp by 12 to get the number of threads across the warp, add to this number 4 extra threads for the selvage or edges of the material. This will give you the total number of threads needed across the warp. The capital T is used throughout these illustrations to mean thread or threads. 12T means 12 threads per inch.

You may want the warp of one color or you may want to make it brighter by using several colors. If more than one color is being used, plan the width for each stripe and then figure the number of threads needed to make this width.

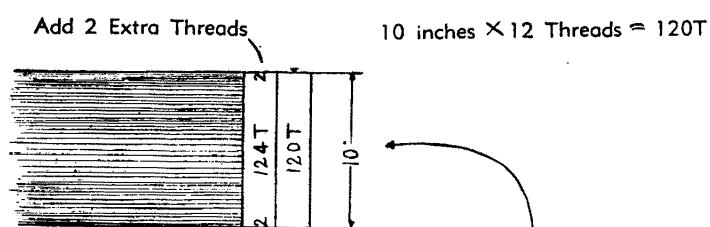

Add 2 Extra Threads For Selvage

Remember to add 2 extra selvage threads to each outside stripe.

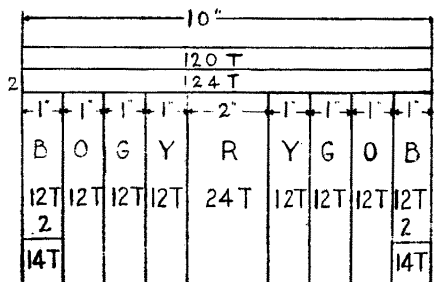

B-blue
O-orange
G-green
R-red
Y-yellow

B. WINDING A NARROW WARP

If you are using carpet warp, place several spools on one or two rods of the skein spreader. Be sure to place each spool so that it will unwind from the top side.

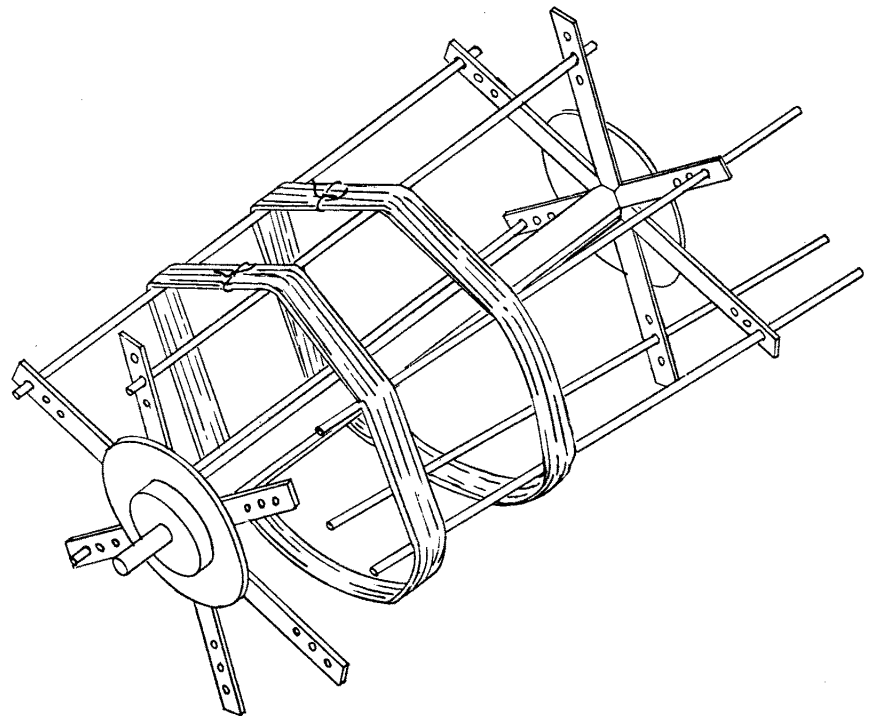
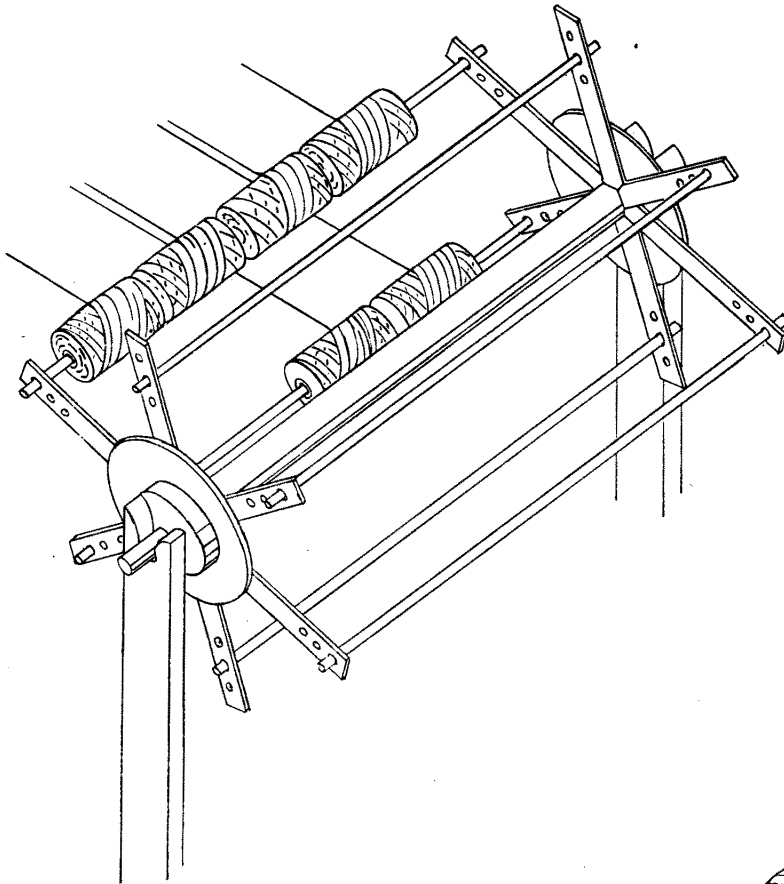

If your thread is in skeins, slip the rods out of one end of the skein spreader and place the skeins over the rods so that they will unroll from the top. Replace the rods so that the skeins are stretched tightly.

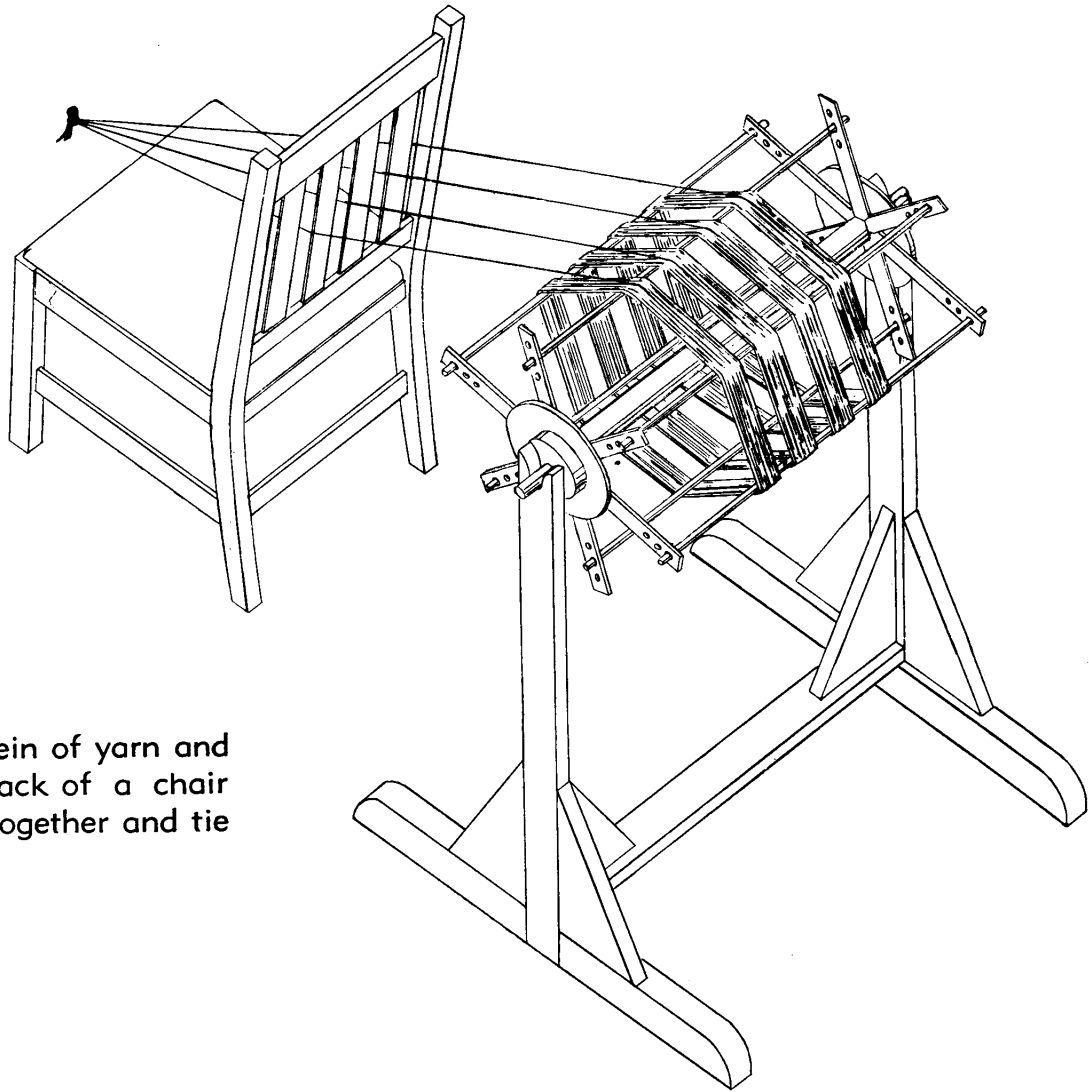

Untie each spool or skein of yarn and thread it through the back of a chair then catch the ends together and tie them in a slip knot.



Details of tying a slip knot.

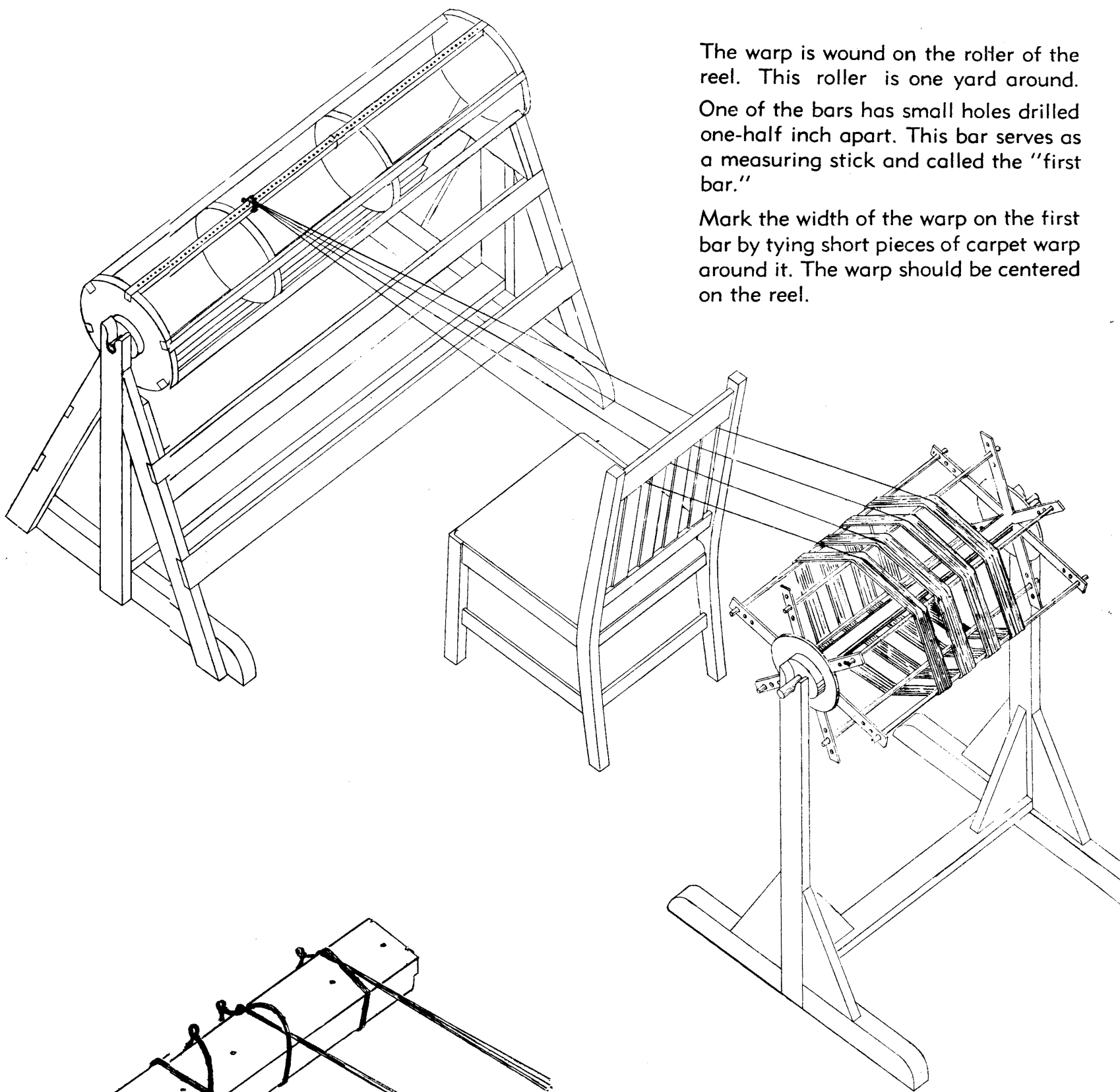

The warp is wound on the roller of the reel. This roller is one yard around. One of the bars has small holes drilled one-half inch apart. This bar serves as a measuring stick and called the "first bar."

Mark the width of the warp on the first bar by tying short pieces of carpet warp around it. The warp should be centered on the reel.

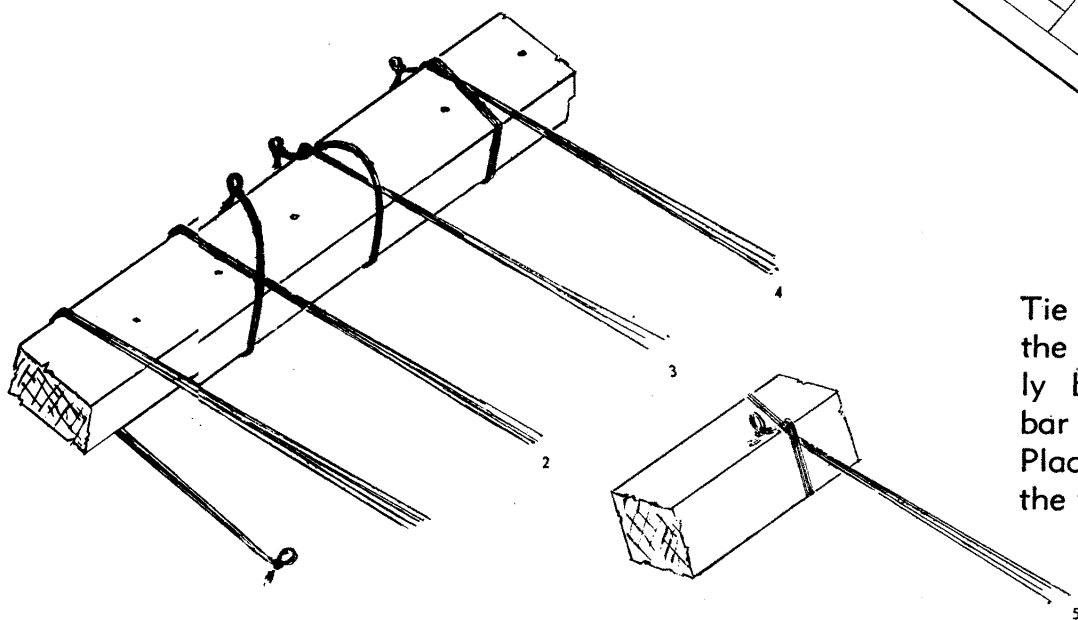

Tie the first group of threads around the first bar. You can do this very easily by wrapping the group around the bar one time and tying a simple knot. Place the crossed part of the knot over the top edge of the bar (5).

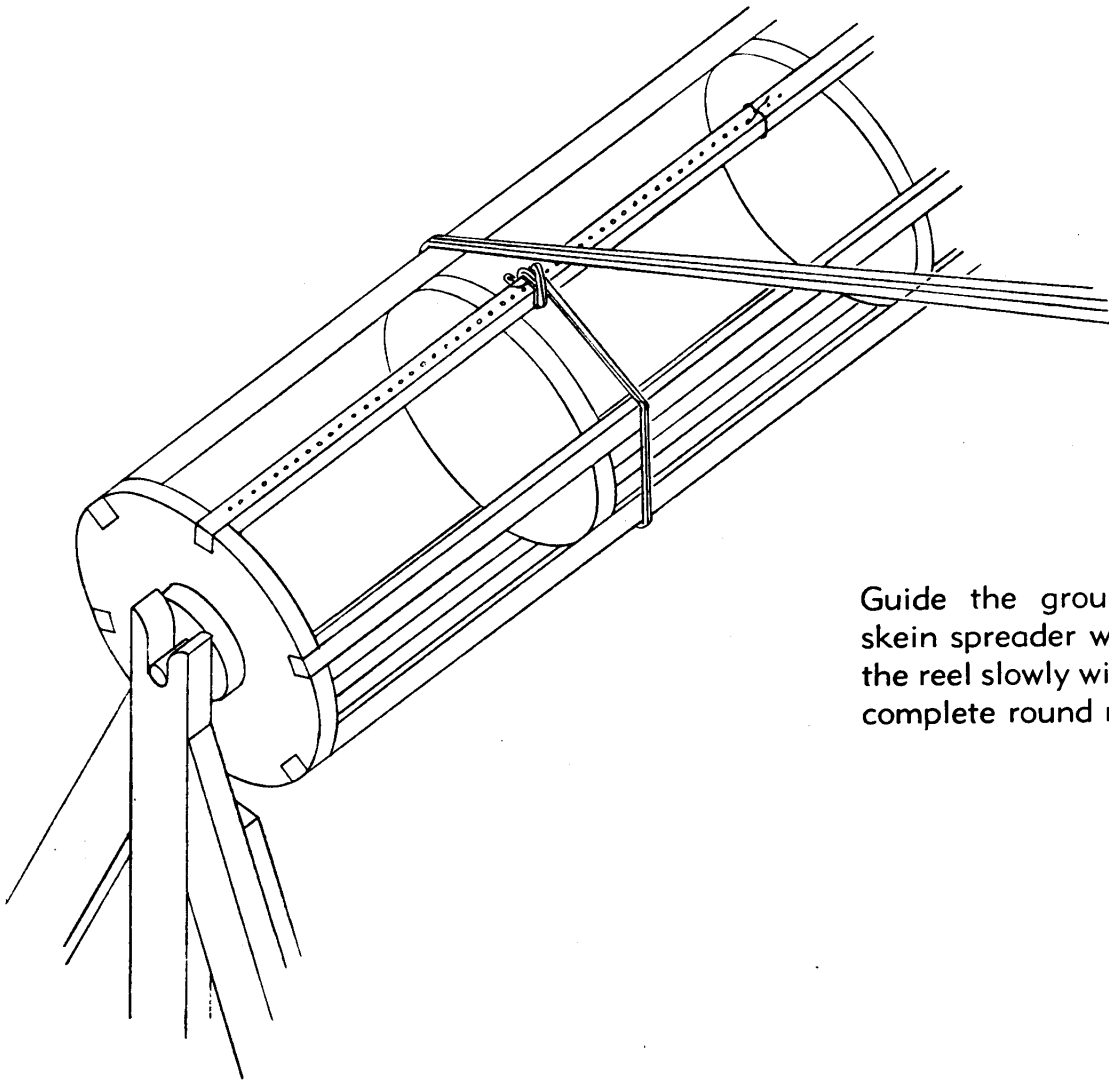

Guide the group of threads from the skein spreader with one hand and turn the reel slowly with the other hand. One complete round measures a yard.

Continue turning the roller and guiding the group of threads so that it falls exactly on top of the first round. Count each round until this group of threads measures the length of the warp you will need. It will take two yards of warp for the two table pieces we planned on

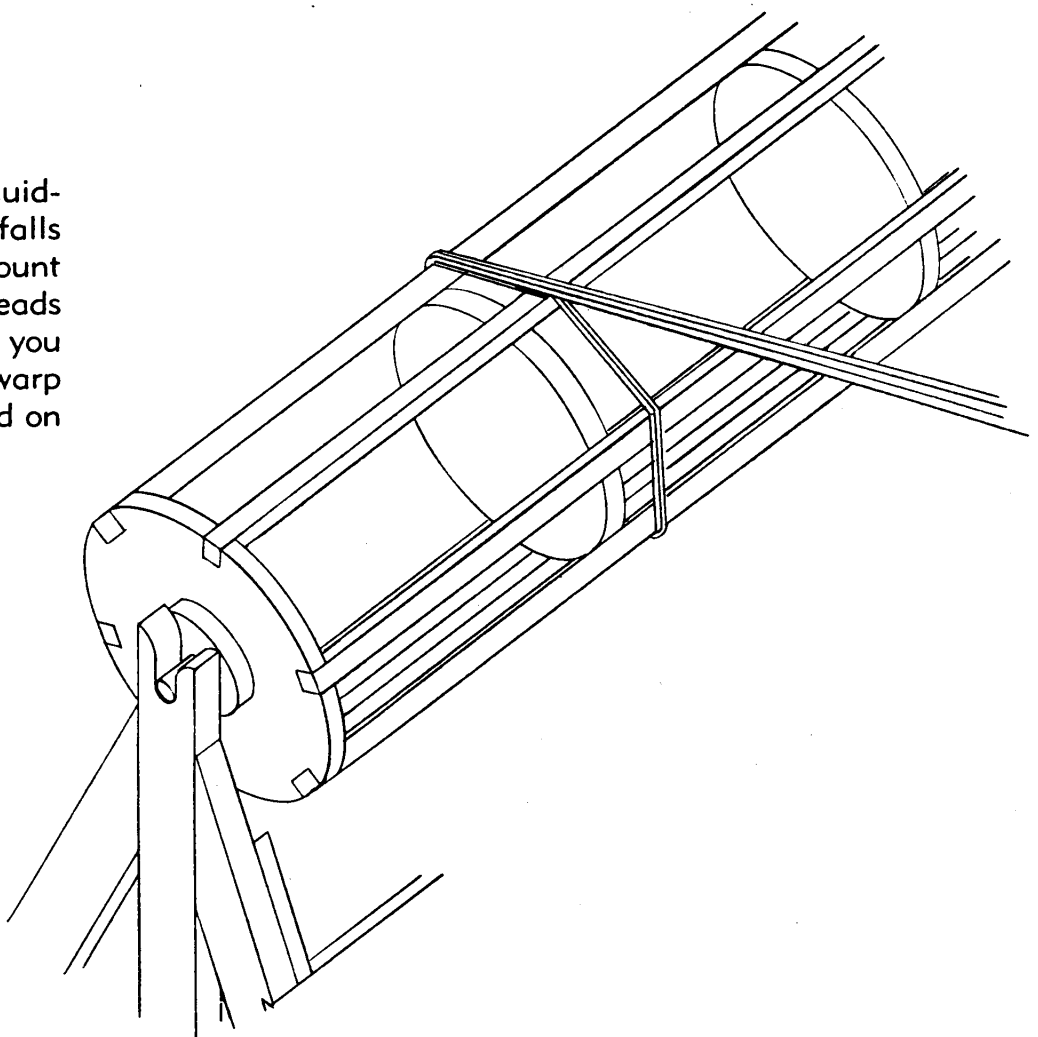

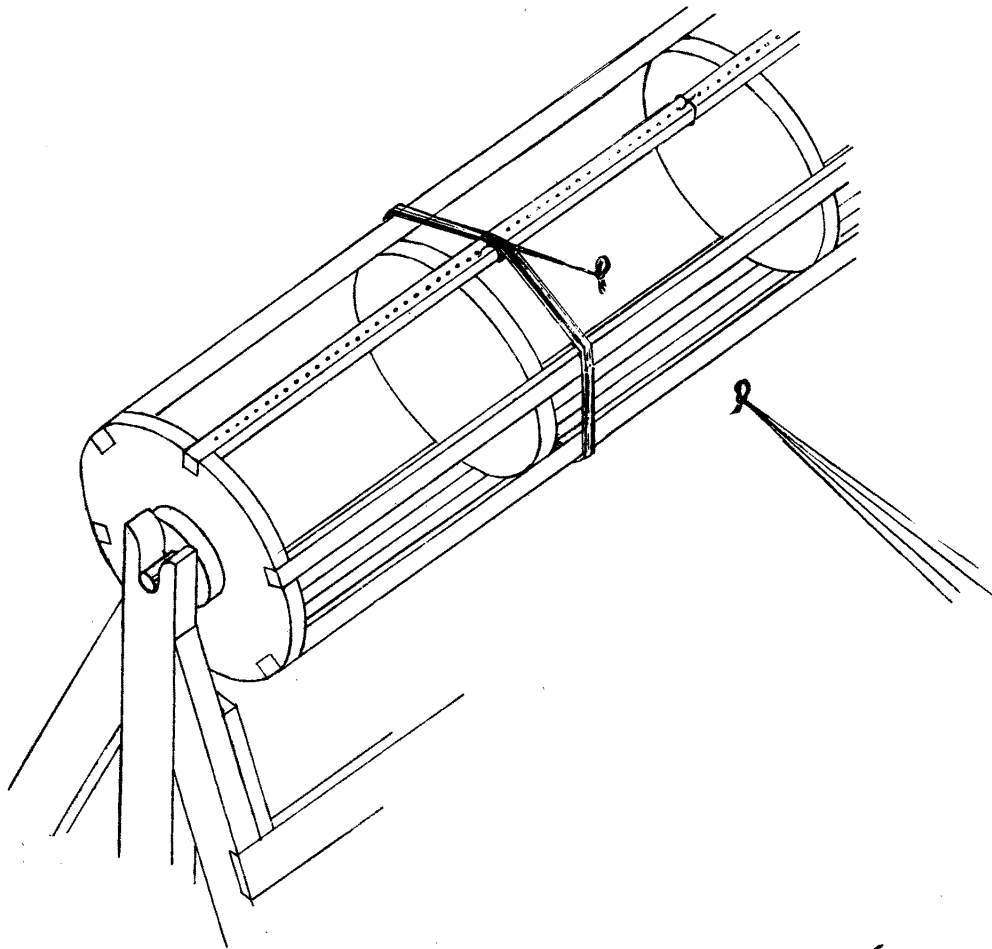

Cut the group of threads and tie slip knots on both ends.

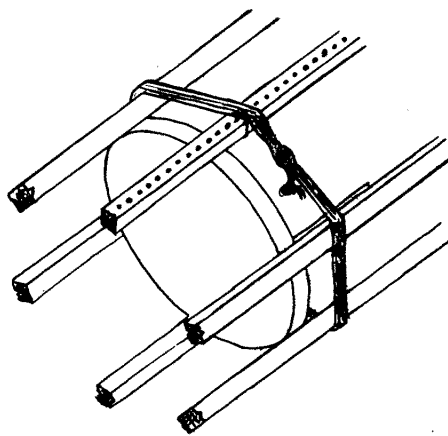

Wrap the end of the first group around the entire amount that has just been rolled on to the reel.

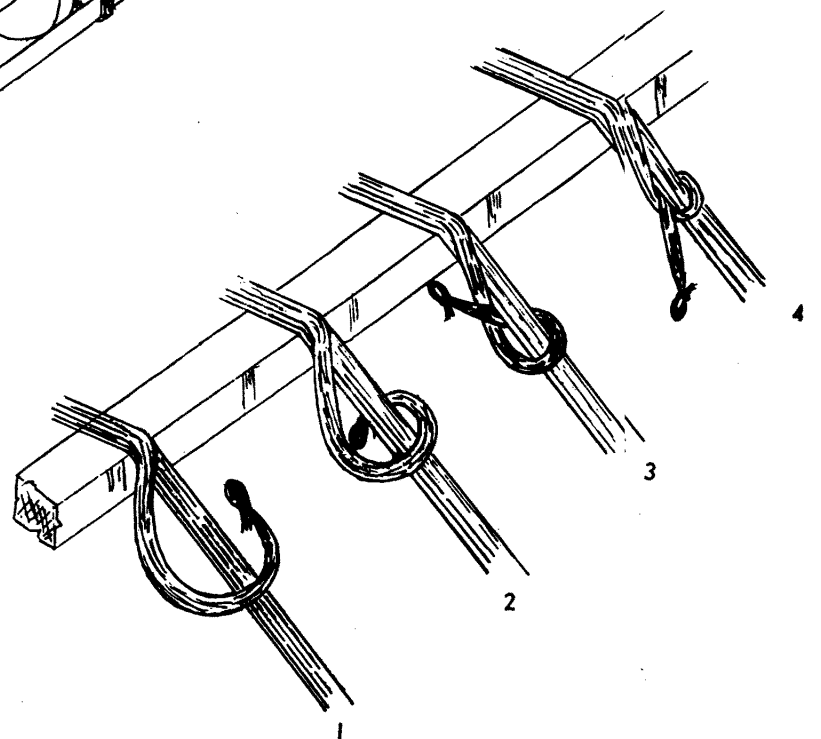

Tie a second group of threads to the first bar just as you did the first group. Wind this group the **same number** of times that you wound the first group. **Be sure to count each round.**

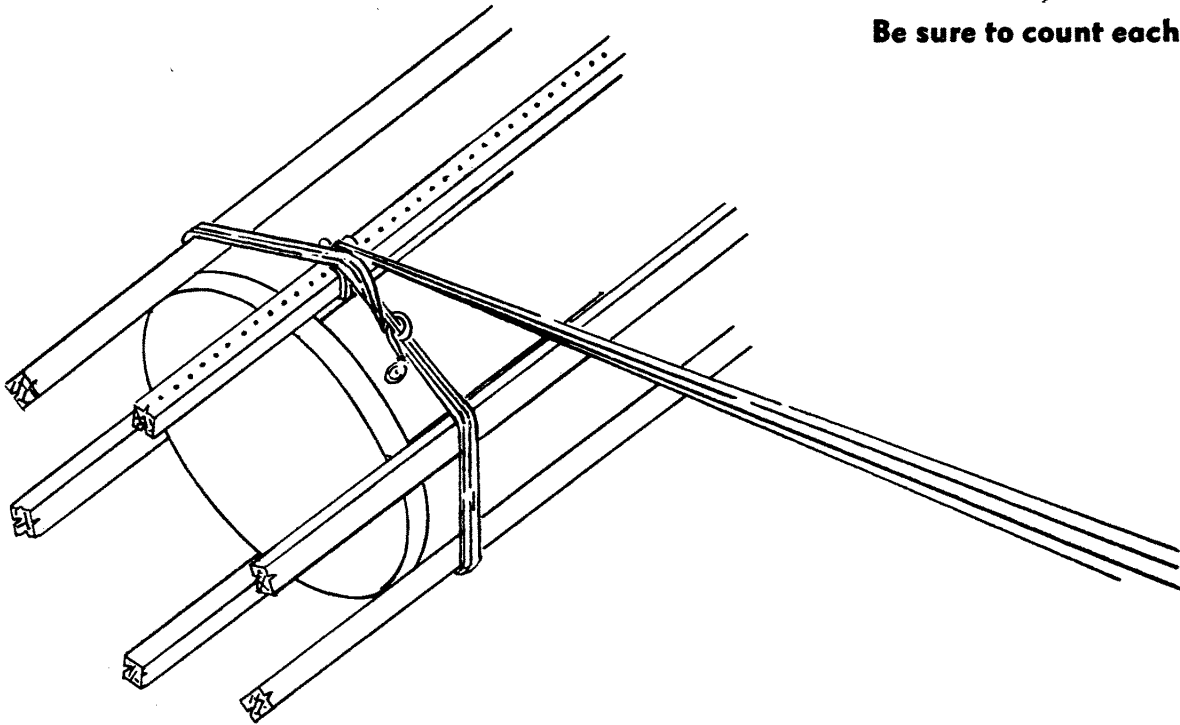

If you are using 4 threads in each group, 3 groups will make 12 threads and this amount should cover one inch on the reel.

The colors may be changed with any group of threads to make the correct number in each stripe of your pattern.

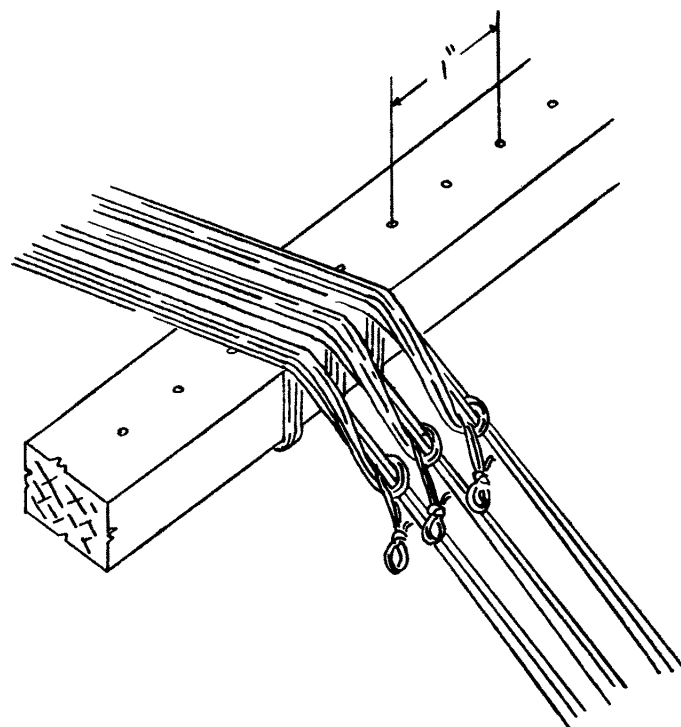

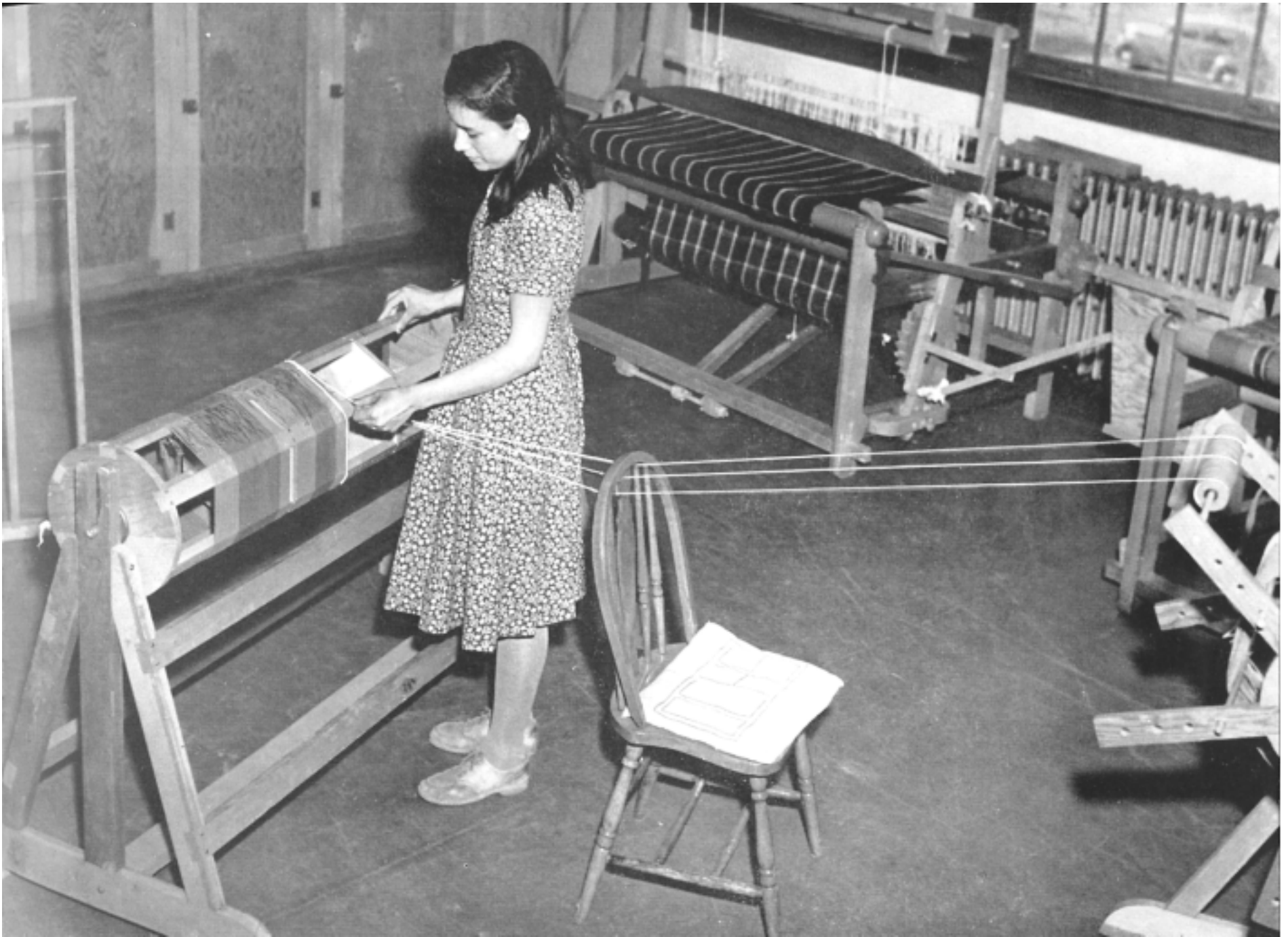

Winding the warp

Continue winding the groups until you have the right number of threads for the total width of the warp. The warp threads should not spread beyond the space that you originally measured for them to cover on the reel.

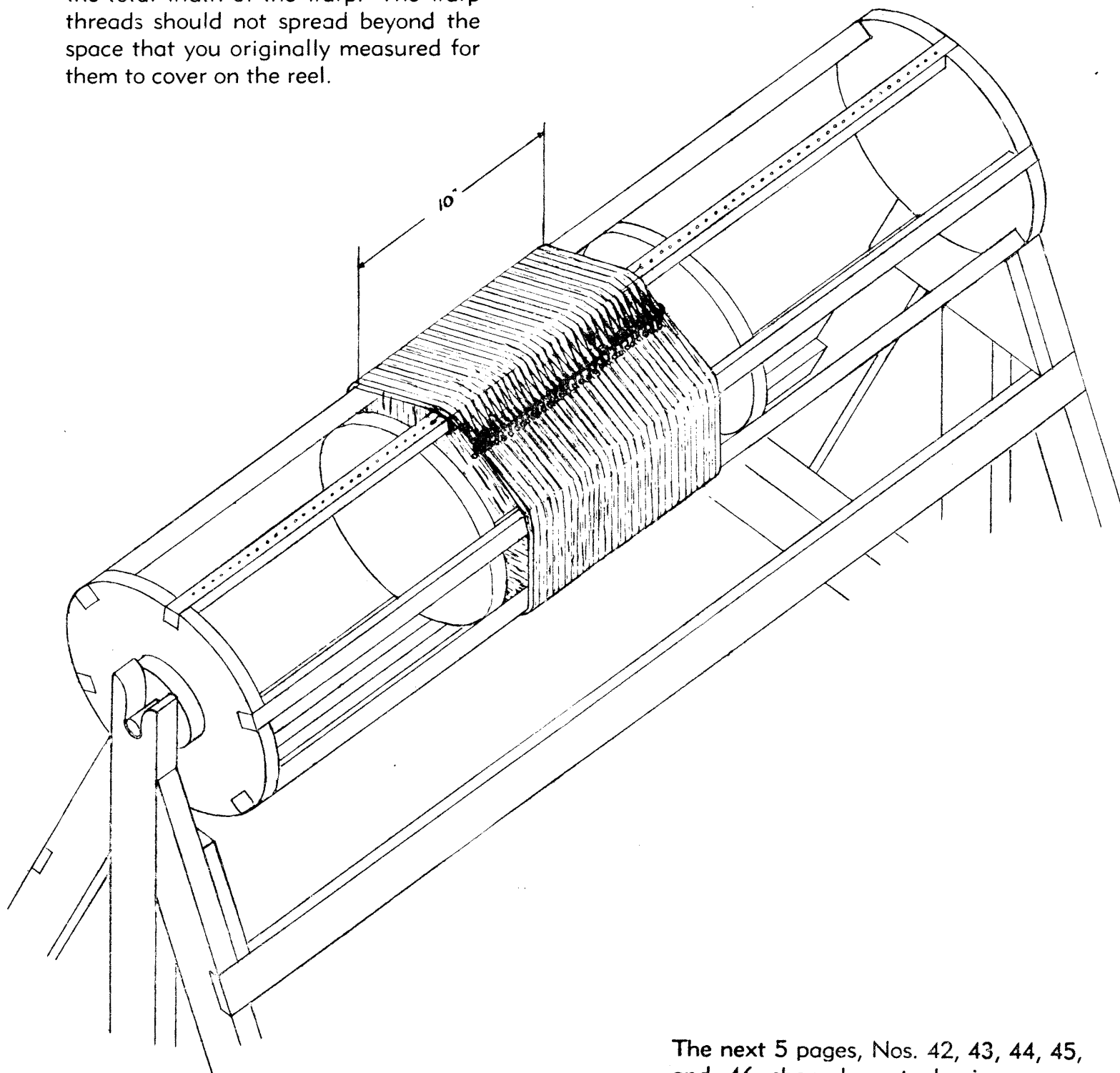

The next 5 pages, Nos. 42, 43, 44, 45, and 46 show how to begin a more difficult piece. If you are making your first piece, skip these pages and continue on page 48. The steps from there on are exactly the same for both a narrow piece or a wide one.

C. PLANNING A LARGER AND MORE DIFFICULT PIECE

A plaid shawl 32 inches wide and 60 inches long is more difficult to make than a table piece. You can save both material and time if you make 3 or 4 shawls on one warp. They can all be different patterns by making some plaid, others with stripes, or by using a different size yarn for the filler. The rest of our story shows you how to plan and make a plain shawl.

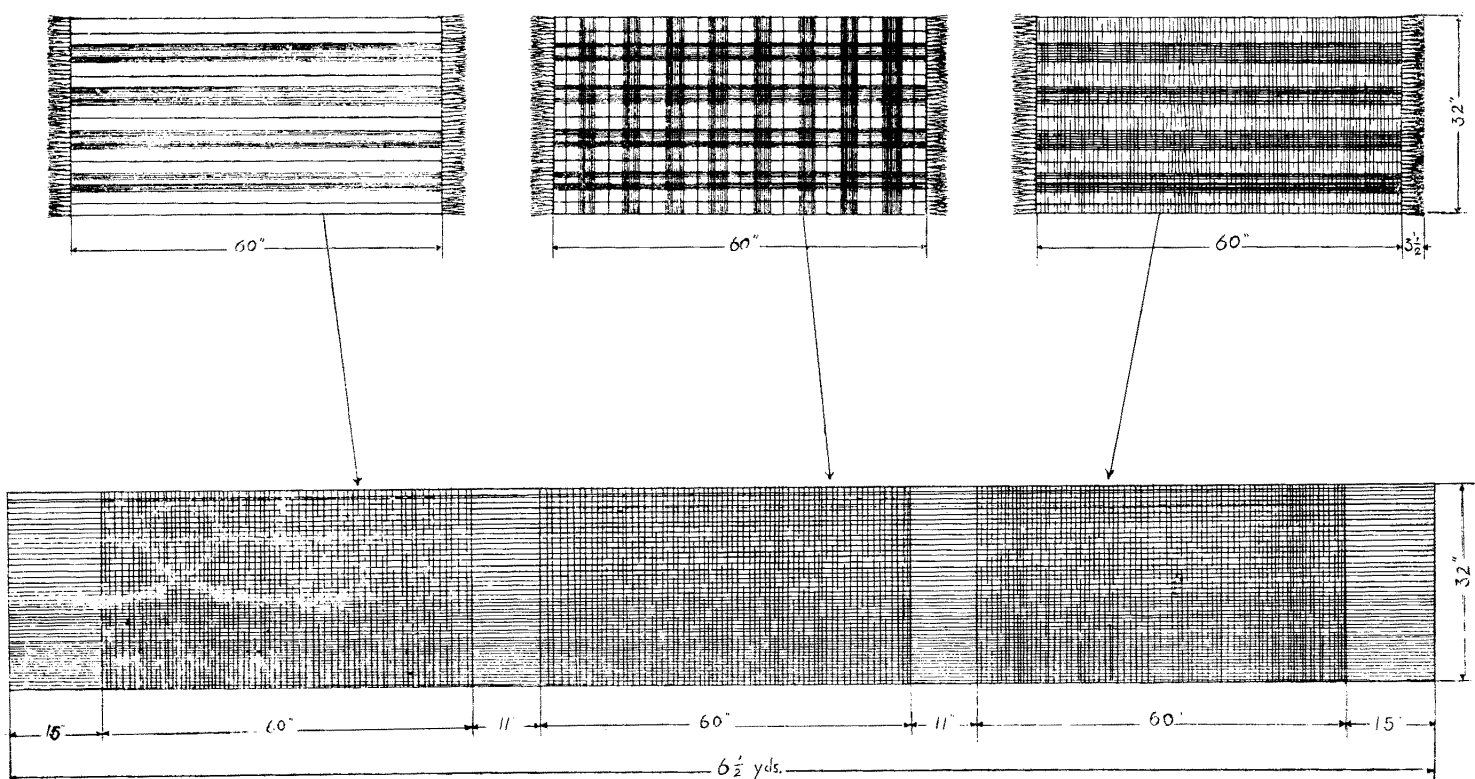
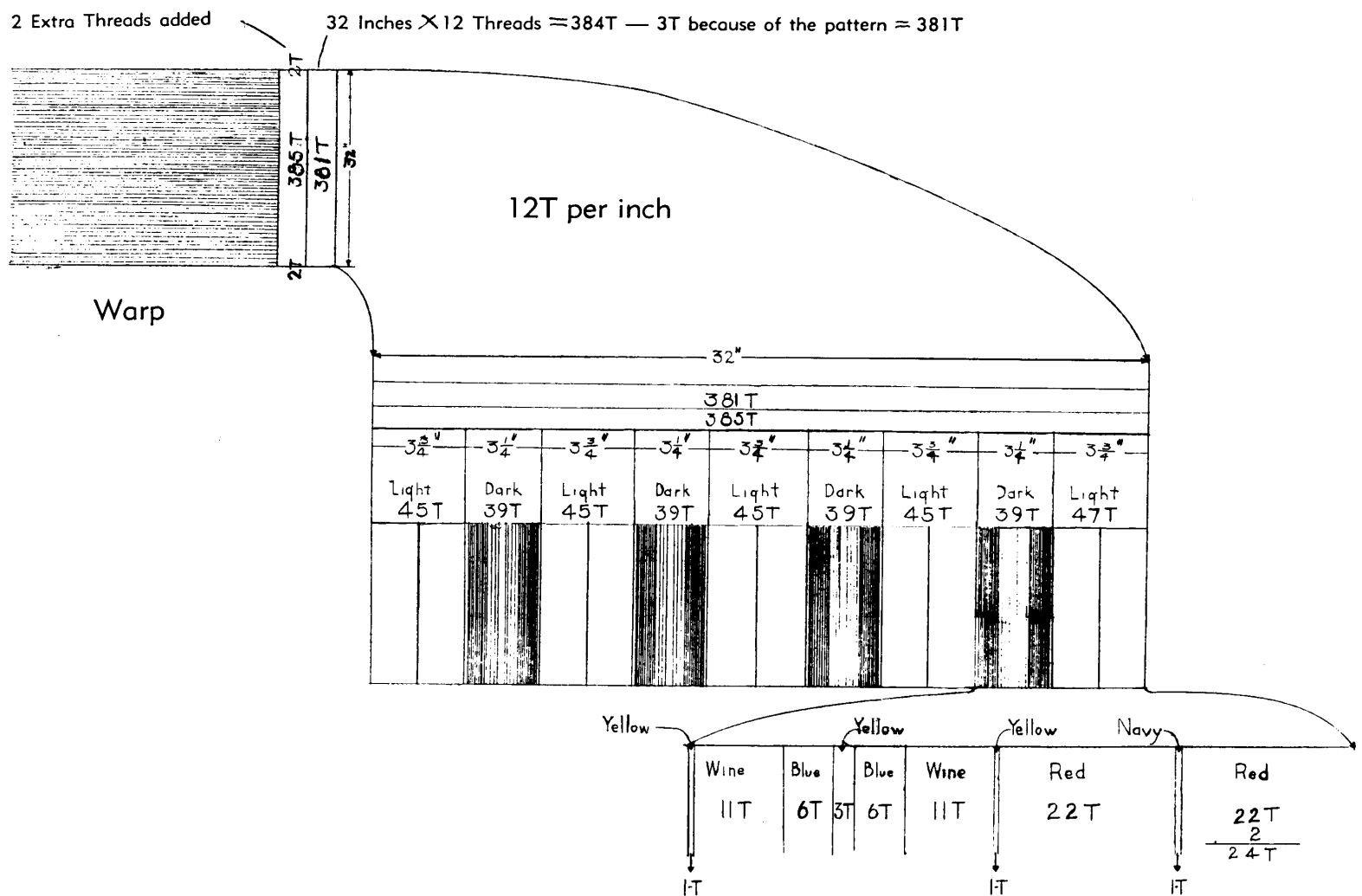

Figure the width and length of the warp as you did for the small table pieces. Take the total length of the three 60 inch shawls and add to this amount two places of 11 inches each for fringe, plus 15 inches on each end of the warp for tying. In this case it will take 6 1/2 yards of warp. The width of the shawl is 32 inches so the width of the warp must be 32 inches or wider. Sometimes it is necessary to add 2 or 3 inches to the width of an article for various kinds of shrinkage. This will depend upon the way you weave, the kind of material you are using, and the method of finishing the article.

Yardage material for dresses and suits made of fine yarn should have a warp 3 or 4 inches wider than you want the finished material. If you are using heavy yarns as in this shawl and are careful with the weaving it will not be necessary to add more than 1 or 2 inches.



Sport yarn used 12T per inch makes a medium weight shawl. If the shawl is 32 inches wide, it will require 381 threads, plus 4 for the selvages, making a total of 385 threads across the warp. To get a plaid pattern make the warp up in different colored stripes. Plan the width of both the light and dark stripes and then select the colors for each and arrange them. Use this same pattern of stripes and colors in the filler to complete the plaid design.

D. WINDING A WIDE WARP

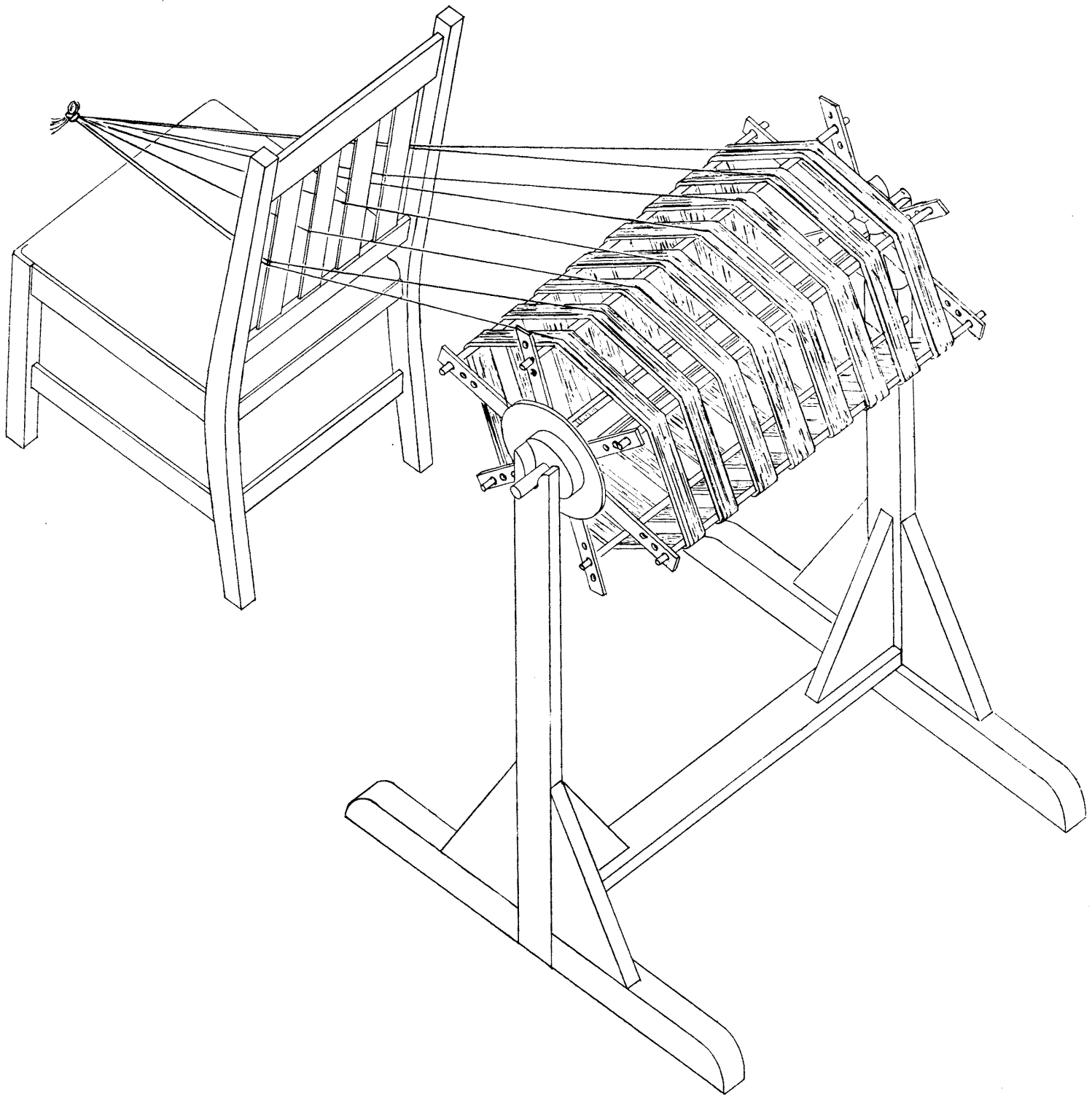

The skein spreader is large enough to hold 12 skeins so that you can use any number of skeins up to that amount at one time. The number you use will depend upon the number of skeins you have of each color. Two threads may be threaded through the same opening in the back of the chair.

Skeins vary in length due to different kinds of yarn. The skeins must be stretched taut in order to unwind them easily. Place them on the skein spreader before untying the ends of the yarn and then adjust the bars to fit the skeins by placing opposite bars in the 1st, 2nd, or 3rd set of holes. Be sure that the opposite bars match in order to keep an even balance on the skein spreader.

Mark the width of the warp on the first bar of the reel, centering it as you did the narrow warp for the table pieces.

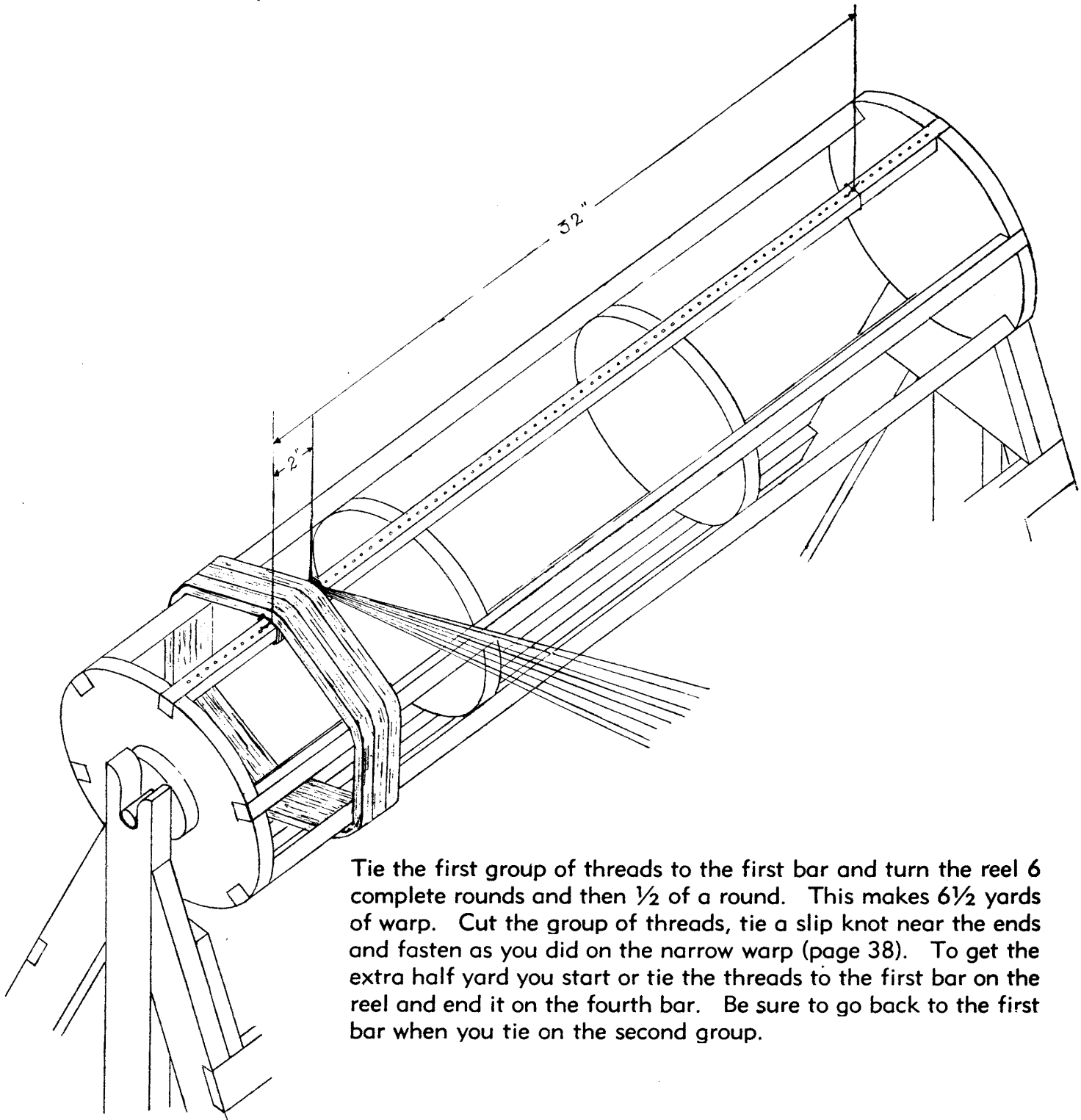

Tie the first group of threads to the first bar and turn the reel 6 complete rounds and then $\frac{1}{2}$ of a round. This makes $6\frac{1}{2}$ yards of warp. Cut the group of threads, tie a slip knot near the ends and fasten as you did on the narrow warp (page 38). To get the extra half yard you start or tie the threads to the first bar on the reel and end it on the fourth bar. Be sure to go back to the first bar when you tie on the second group.

We are using 8 threads in each group so that 3 groups make 24 threads. This number should cover 2 inches on the reel. Hold the threads firmly with one hand and guide them so that they will cover the correct space on the reel. Change the colors on the skein spreader whenever necessary to get the right number of threads in each stripe

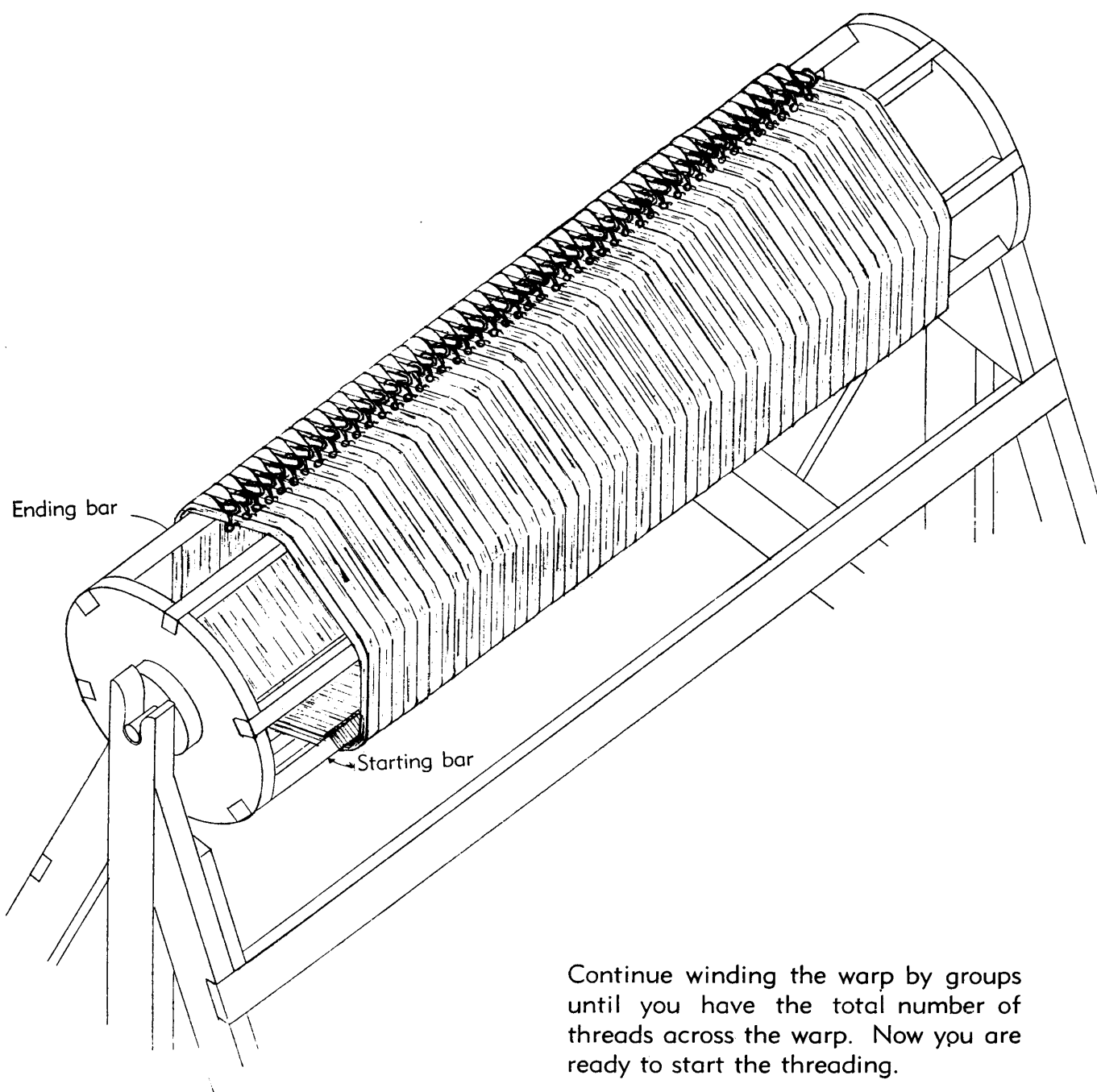

Continue winding the warp by groups until you have the total number of threads across the warp. Now you are ready to start the threading.

4. THREADING AND ROLLING THE WARP

A. THREADING THE REED

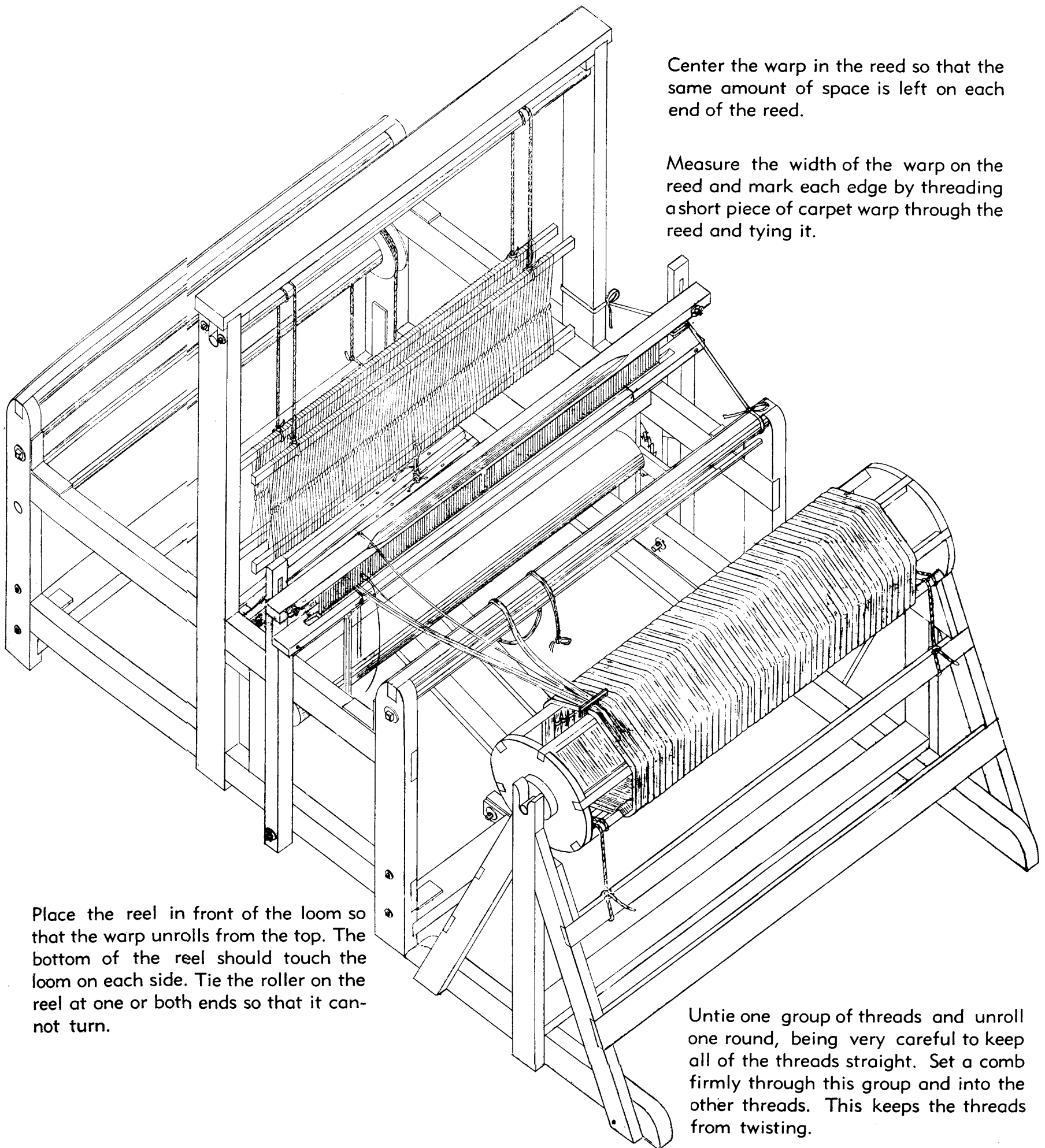

Center the warp in the reed so that the same amount of space is left on each end of the reed.

Measure the width of the warp on the reed and mark each edge by threading a short piece of carpet warp through the reed and tying it.

Place the reel in front of the loom so that the warp unrolls from the top. The bottom of the reel should touch the loom on each side. Tie the roller on the reel at one or both ends so that it cannot turn.

Untie one group of threads and unroll one round, being very careful to keep all of the threads straight. Set a comb firmly through this group and into the other threads. This keeps the threads from twisting.

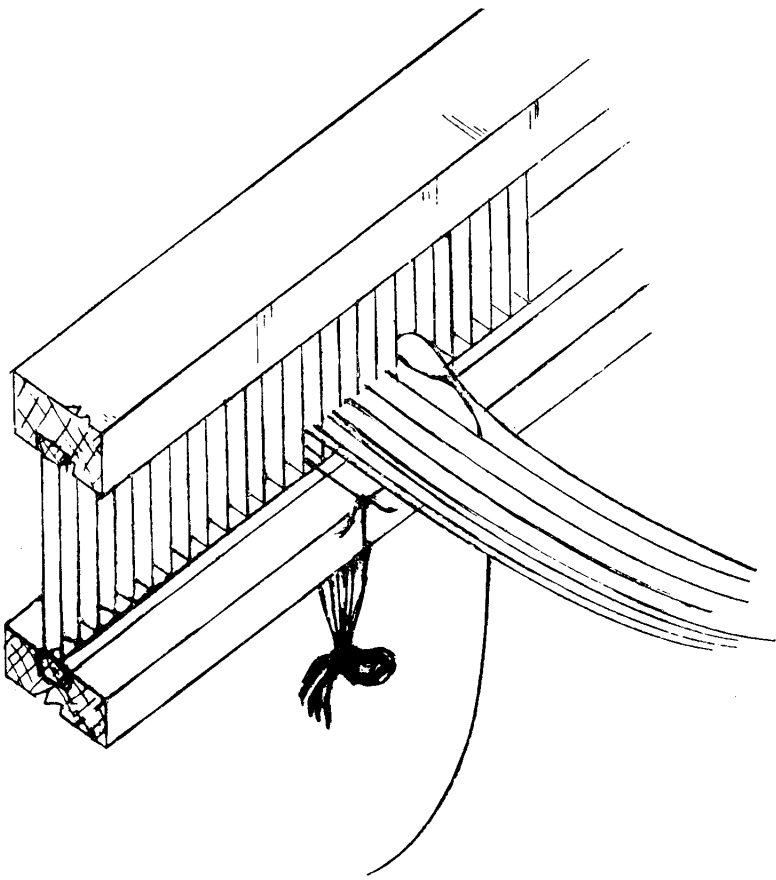

Untie the slip knot and select the two outside threads, fold a small loop near the end of the threads and slip them through the reed over the first marker. Put the next 2 threads through the next dent. These double threads make the selvage. Place one thread in the third dent and continue threading each dent with one thread until this group is completed.

Remove the comb and untie 2 or 3 groups on the reel. Unwind these as you did the first group. Reset the comb and continue threading through the reed. After 2 or 3 inches have been threaded, check very carefully for mistakes and then tie this amount with a loose slip knot.

Continue threading until all of the warp threads have been pulled through the reed. Count the number of threads of each color carefully so that the stripes will be correct. Double the last 2 threads for the selvage, just as you did in the beginning.

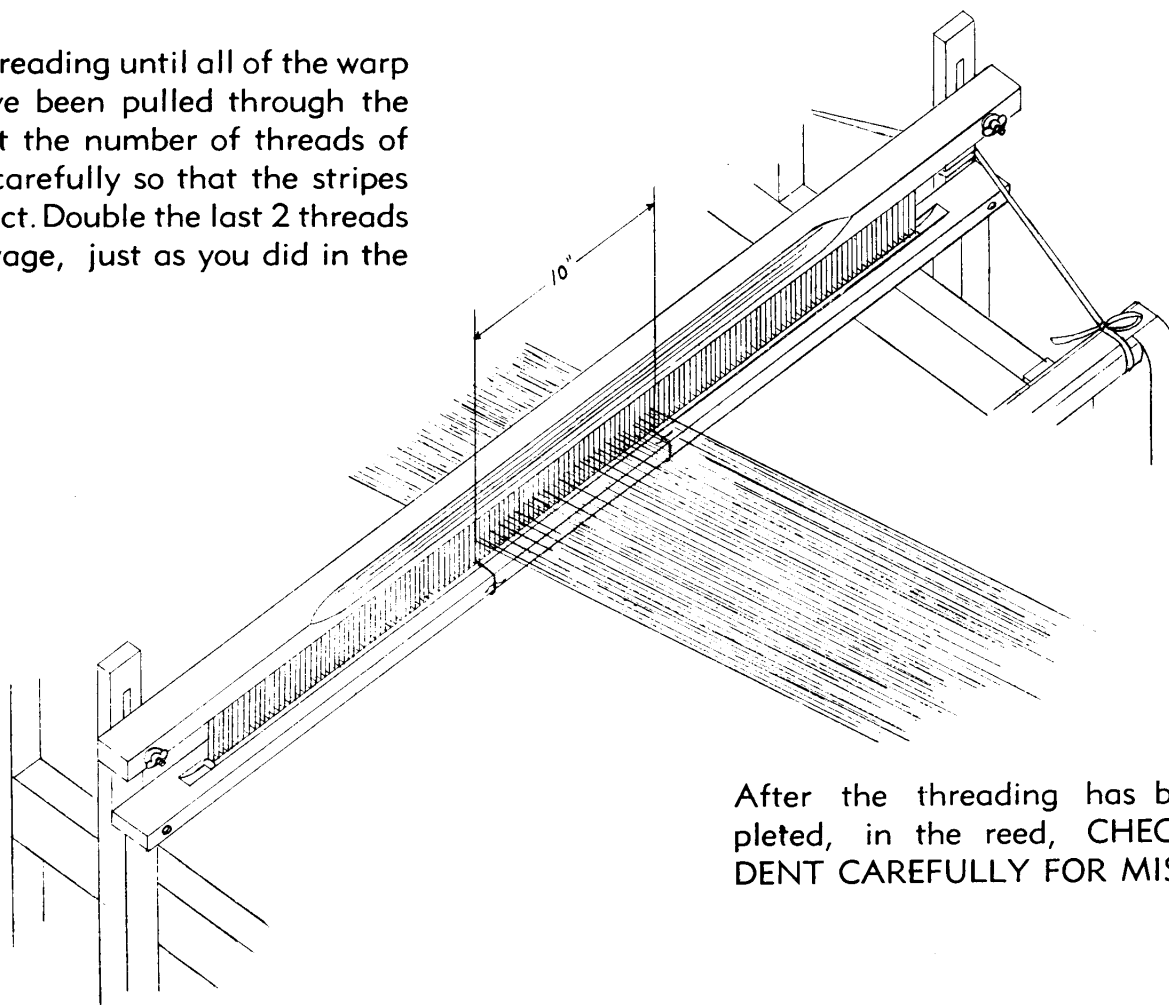

After the threading has been completed, in the reed, **CHECK EACH DENT CAREFULLY FOR MISTAKES.**



Threading the reed

B. THREADING THE HARNESSES

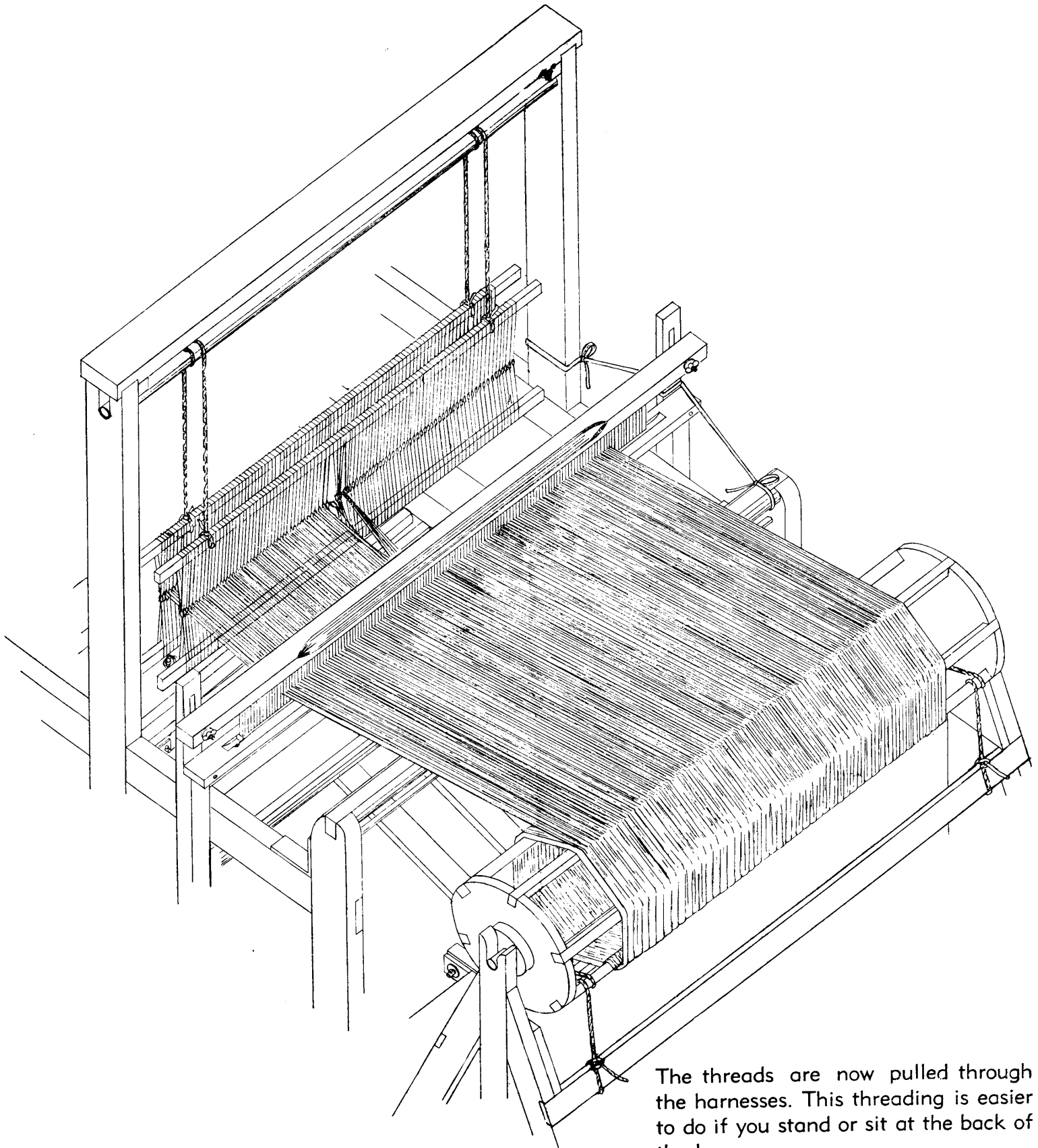

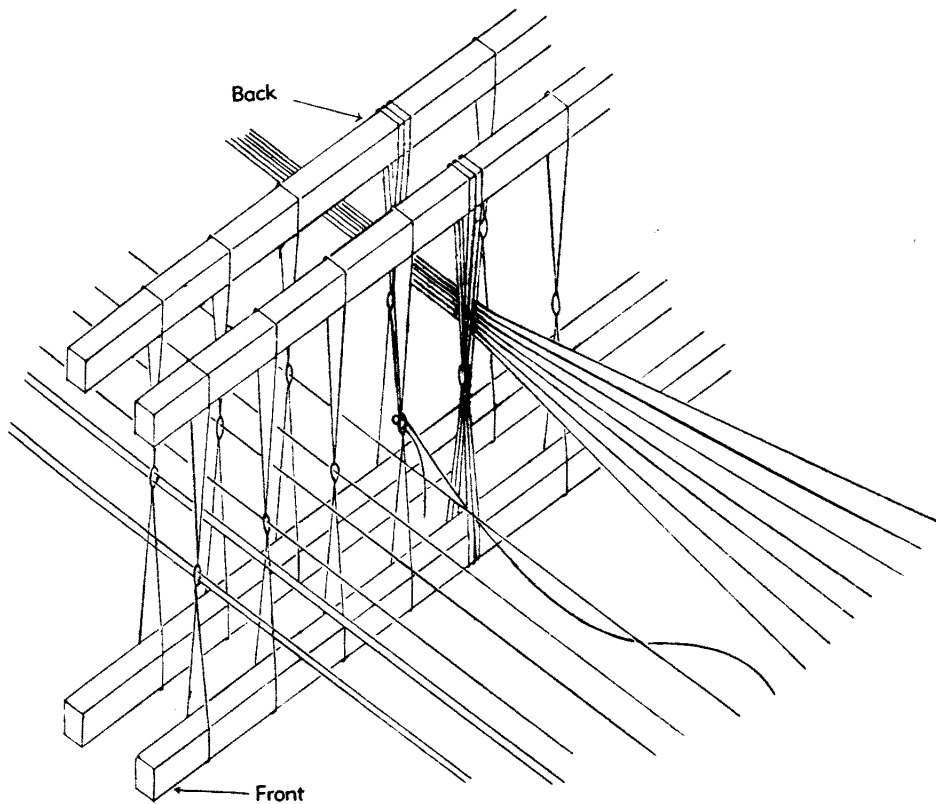

Untie the first group of threads on the right hand side when standing at the back of the loom. Select the first 2 selvage threads and pull them through the eye of a heddle on the front or first harness. Thread the next 2 selvage threads through a heddle on the second or back harness.

Be very careful in picking up the threads along the reed. Do not cross the threads between the reed and the harness. This serious mistake is shown on the left side of the drawing below.

Pull the first single thread through the first harness and the next thread through the second harness. Continue this threading through the first and second harnesses until the first group of warp threads has been completed. Check very carefully to see that each thread is in the right place.

The straight threads on the right side are threaded correctly through the reed and harnesses.

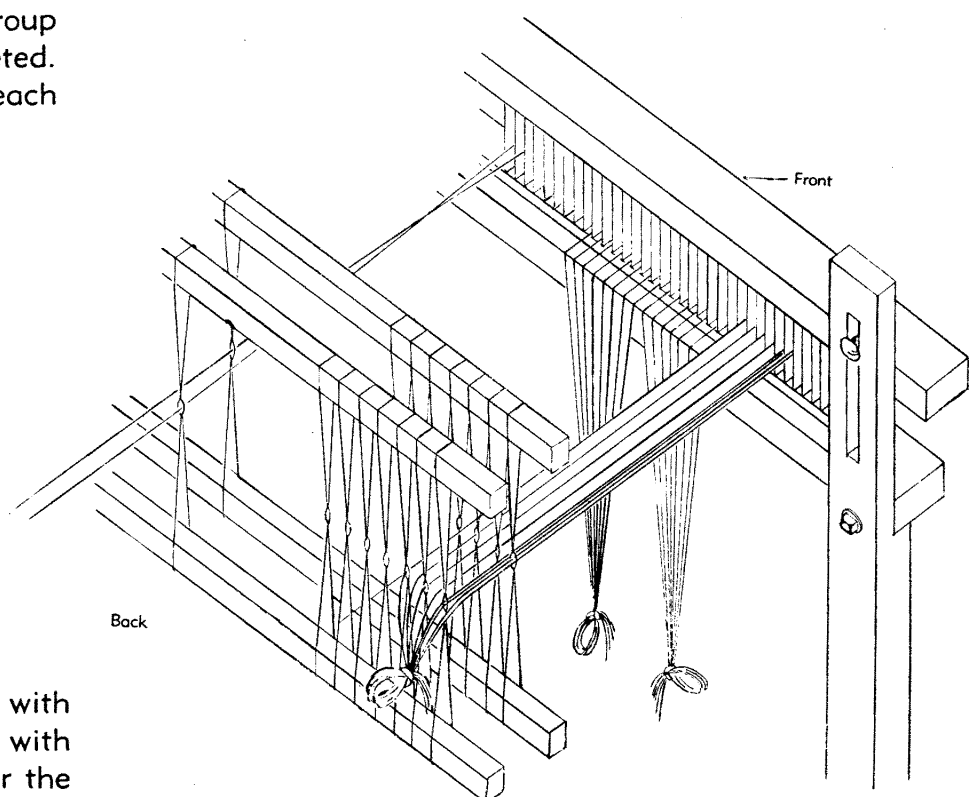

Tie the first group of warp threads with another loose slip knot. Continue with the second group of threads. After the threading is completed in the harnesses, **CHECK EACH THREAD VERY CAREFULLY.**

Sometimes it is easier to thread the reed and harnesses while they are out of the loom.

Remove the reed from the beater frame and hang it in front of the reel and thread as you would in the loom. After the threading is completed, tie the reed to the reel.



Remove the harnesses from the loom and hang them in front of the reed. Thread the harnesses as if they were in the loom.

When the threading is completed, place the reel in front of the loom and replace the reed in the beater frame and hang the harnesses in place.

C. TYING THE WARP TO THE APRON

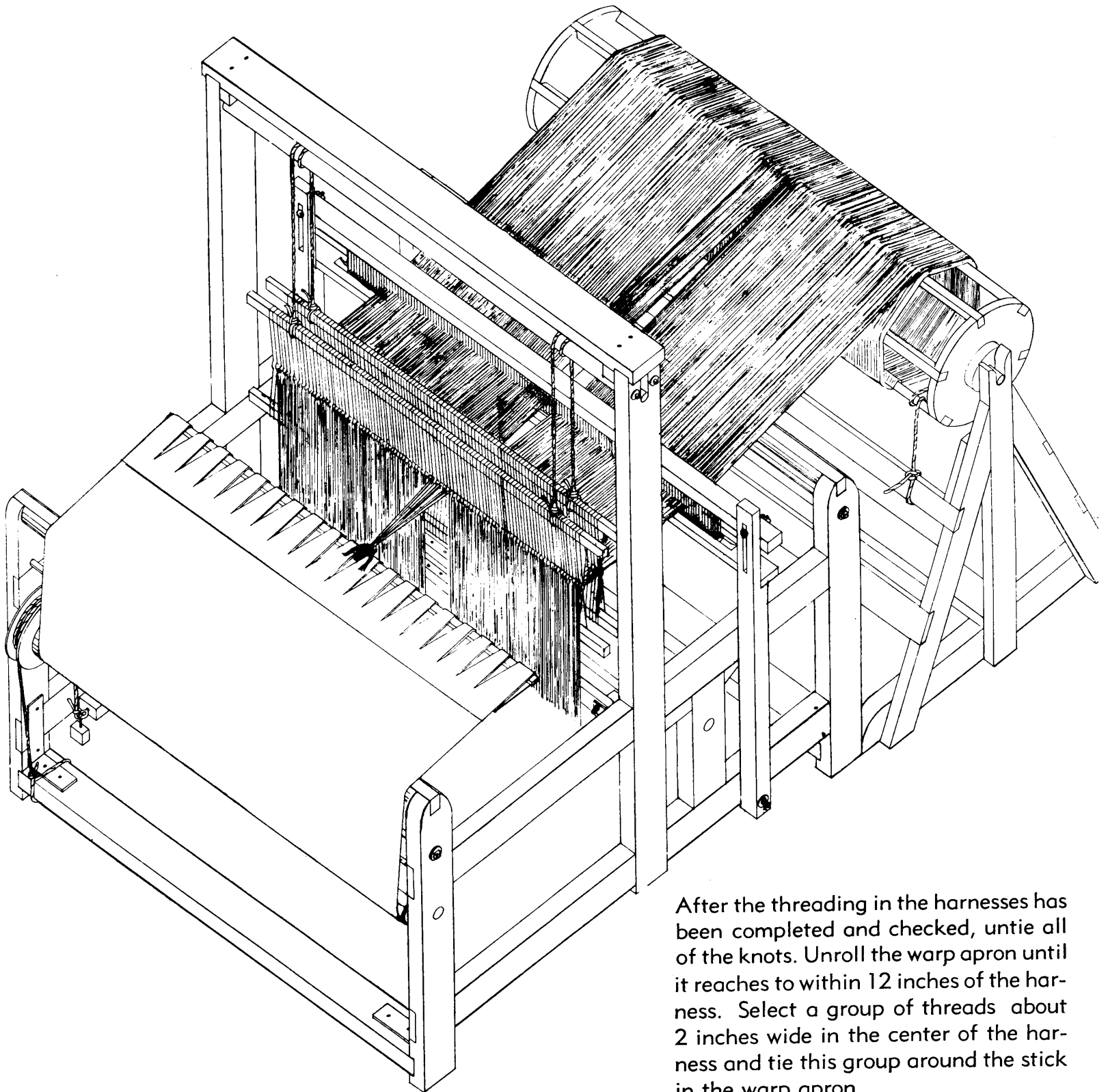

After the threading in the harnesses has been completed and checked, untie all of the knots. Unroll the warp apron until it reaches to within 12 inches of the harness. Select a group of threads about 2 inches wide in the center of the harness and tie this group around the stick in the warp apron.

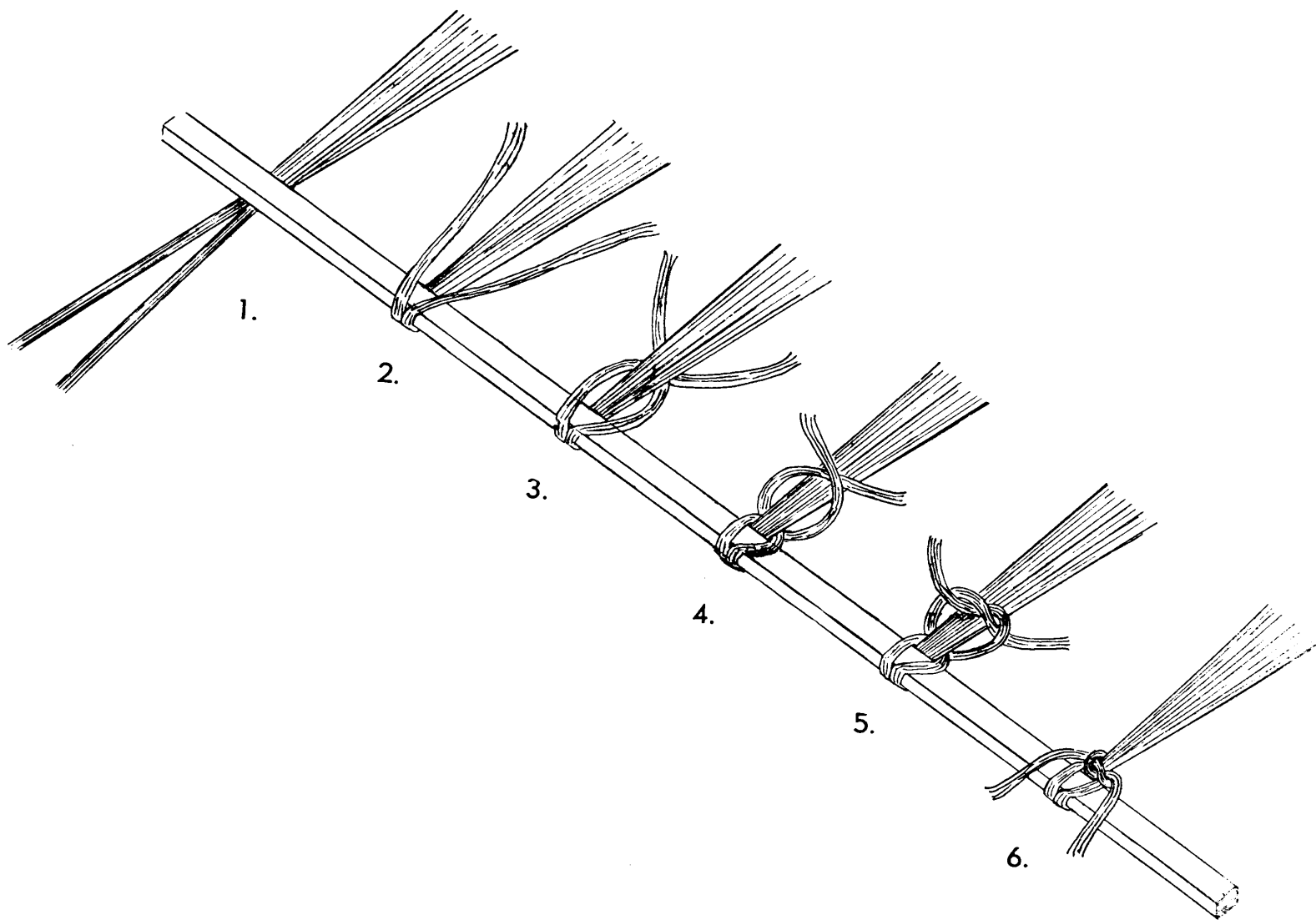

Place the group of threads under the apron stick (1), pull it up firmly, divide into two parts (2). Wrap each end around the main group (3) and tie a simple knot on the top side of the warp (4, 5, 6).

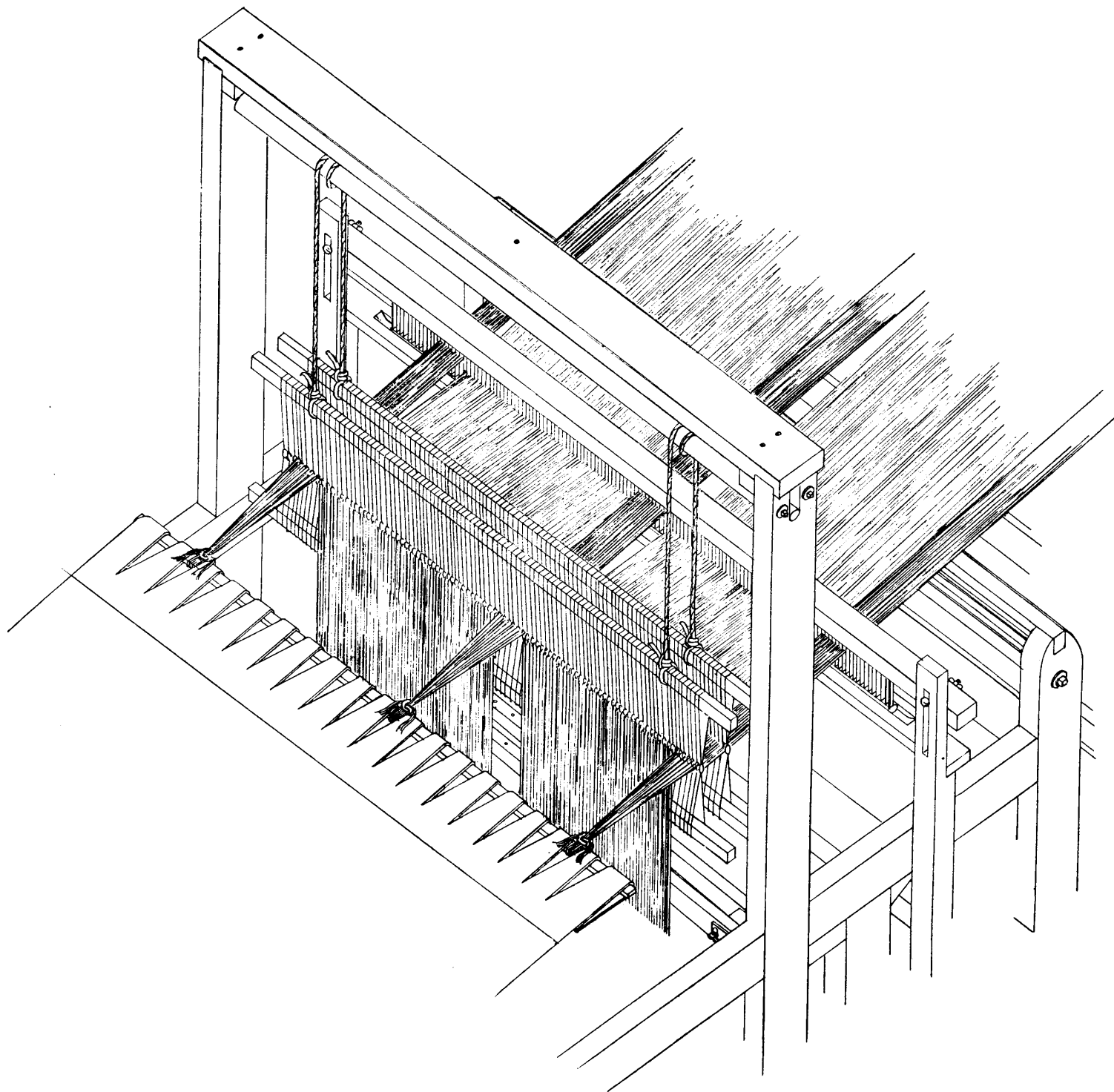

Tie a group on each edge of the warp
in the same way you did in the middle.

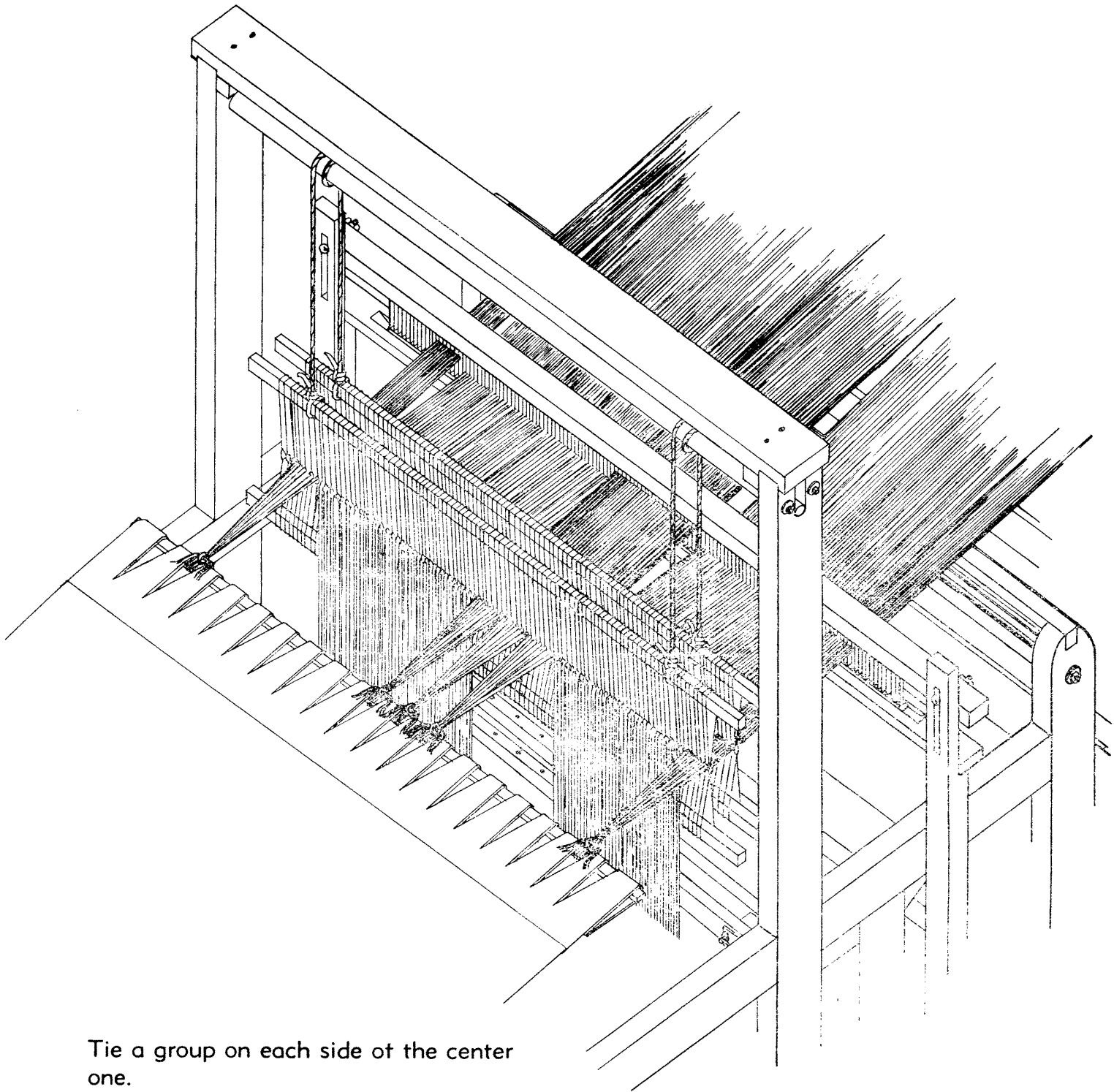

Tie a group on each side of the center one.

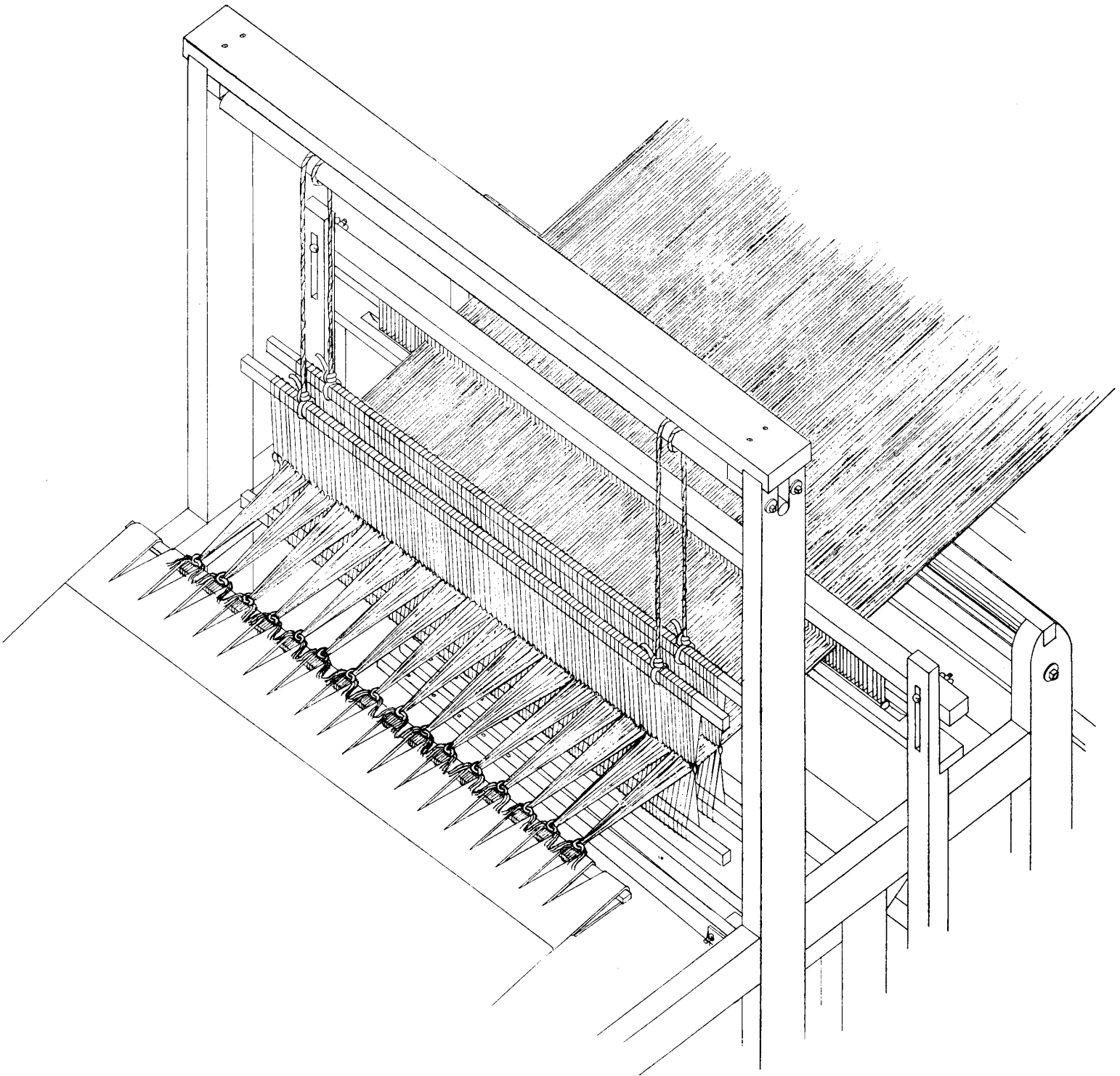

Continue tying back and forth on either side until a group of warp threads is tied in each space on the warp apron for the width of the warp. You will find that the first group you tied in the center and the side groups are looser than the others. Loosen the knots in these and adjust until the tension of each group is exactly the same. You can test this tension by pulling your hand across the threads just back of the harness. It is very important that each group has exactly the same tension.

D. ROLLING THE WARP ON TO THE WARP BEAM

You will need help doing this next step. Untie the roller on the reel and have another person hold the roller firmly. Start rolling the warp beam by turning the drum to the right. The person holding the reel serves as a brake and does not allow the roller to turn rapidly. **The warp should be taut or tight at all times.** Wind the warp beam until the apron has been wound up and the threads have made one complete round on the beam and the knots are on top.

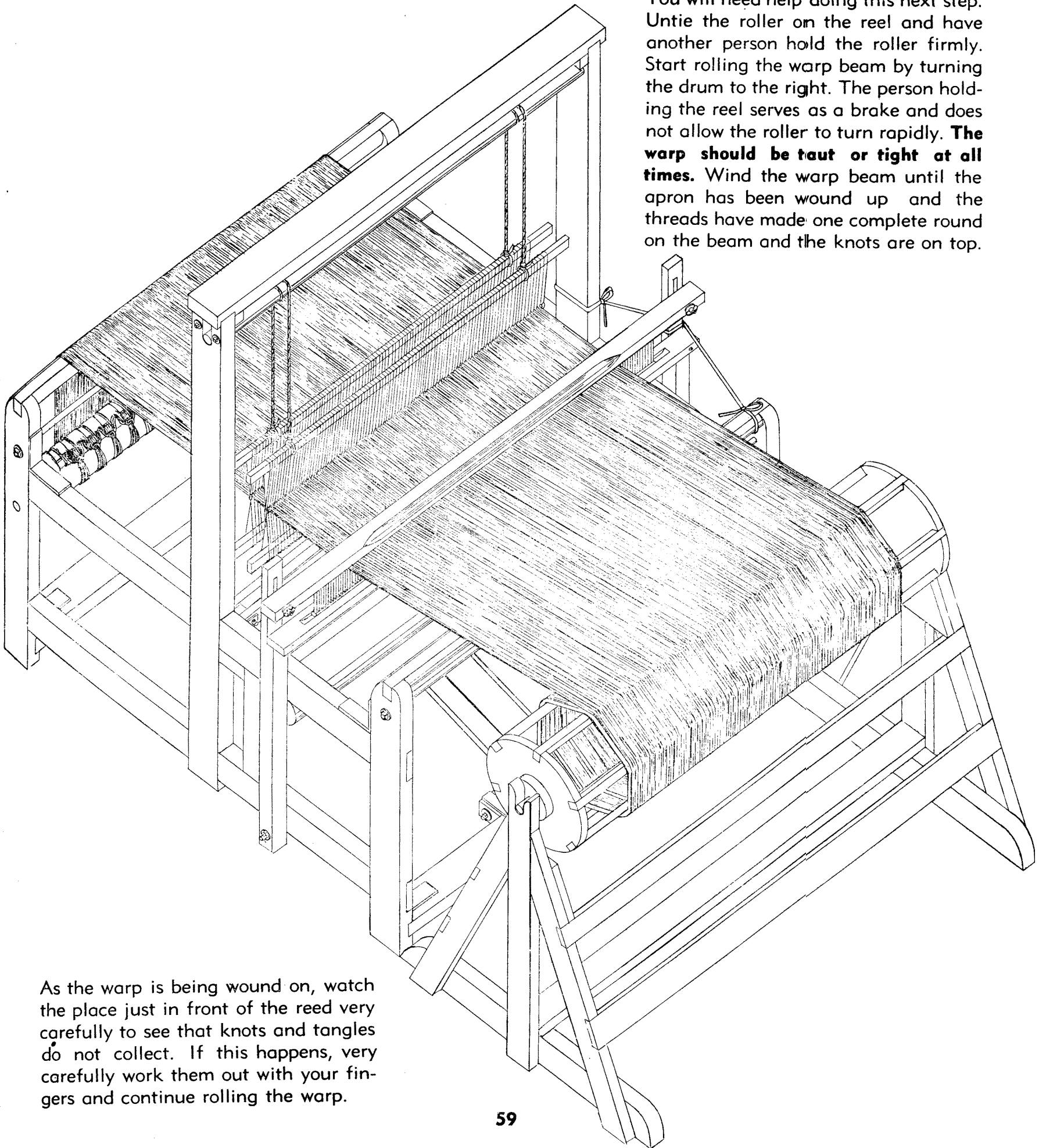

As the warp is being wound on, watch the place just in front of the reed very carefully to see that knots and tangles do not collect. If this happens, very carefully work them out with your fingers and continue rolling the warp.

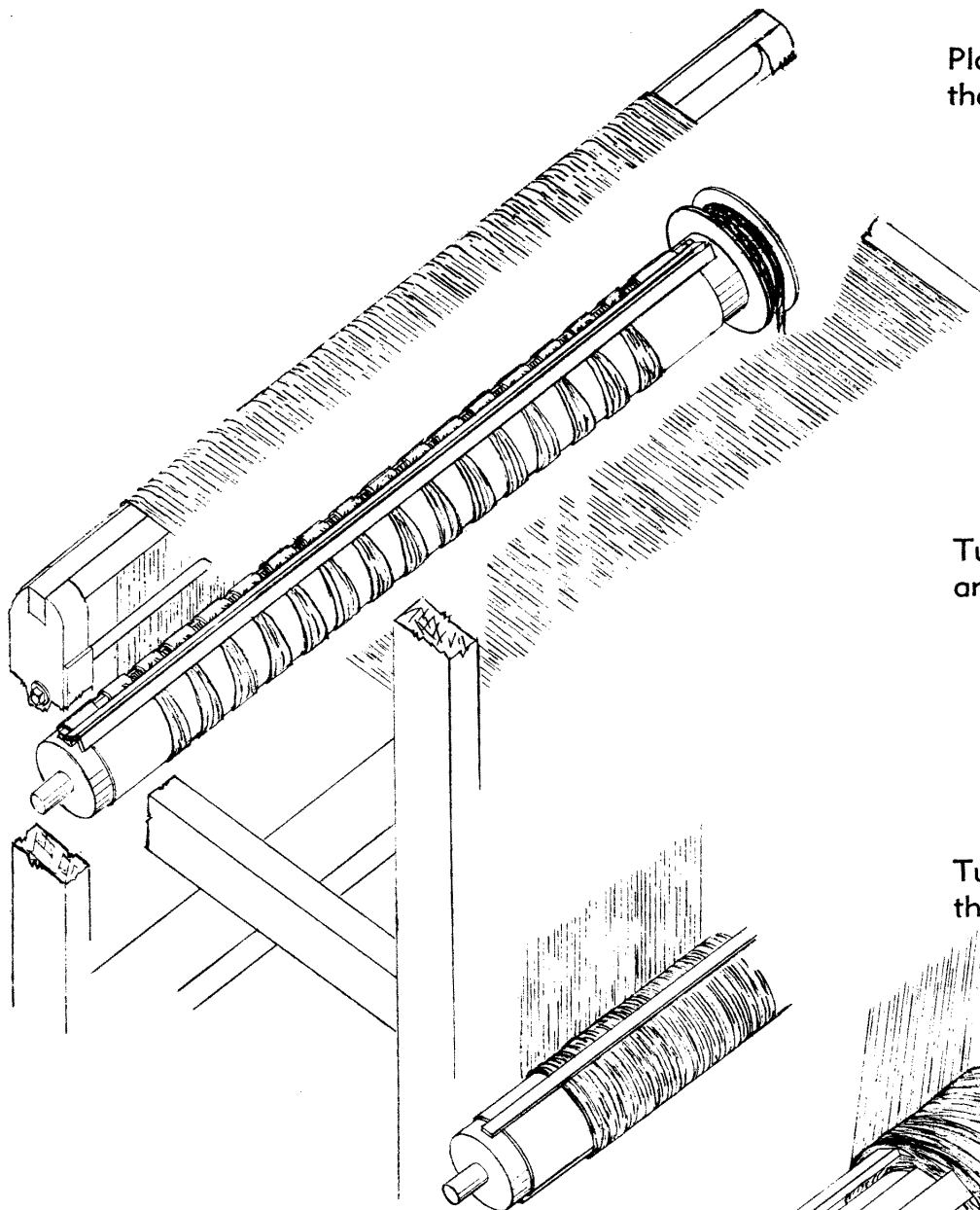

Place two warp sticks over the knots so that they are completely covered.

Turn the beam one-third of a round and place in another warp stock.

Turn another one-third and place in the fourth stick.

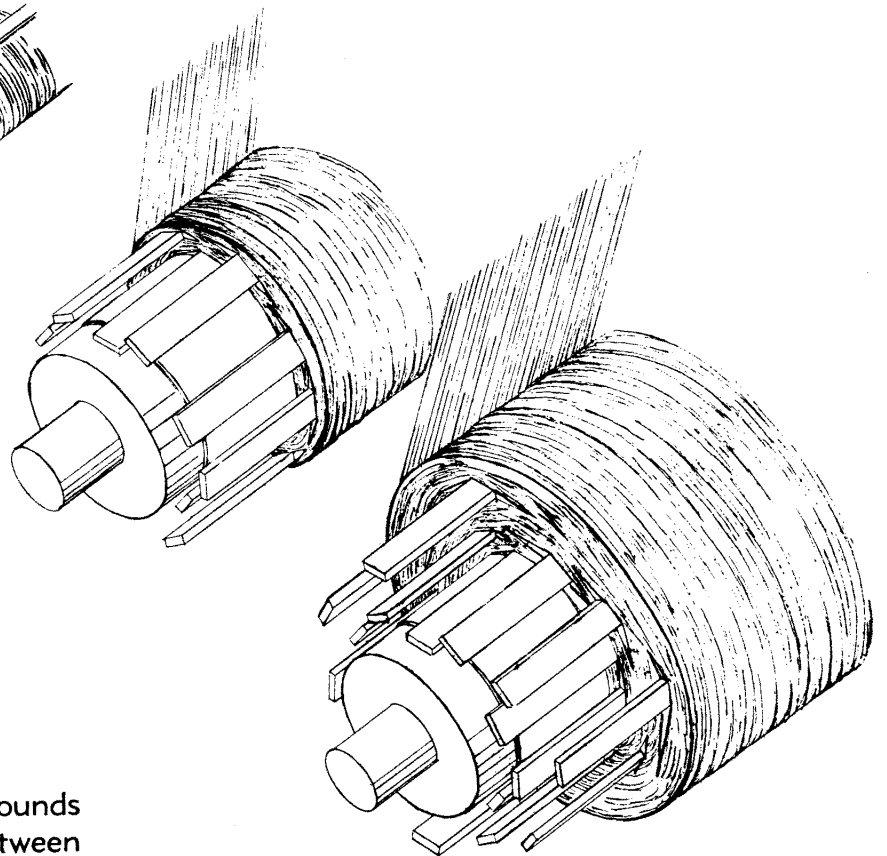

After this you can turn 2 or 3 rounds and again place in warp sticks between the ones on the first round. Continue winding and using warp sticks whenever needed to make the warp smooth and even. Do not let it pile up in ridges.

When the end of the warp has been reached on the roll, untie the threads by simply pulling them up. Have your helper hold half of the threads in one hand and half in the other hand. Continue rolling the warp beam until the end of the warp is just in front of the reed.

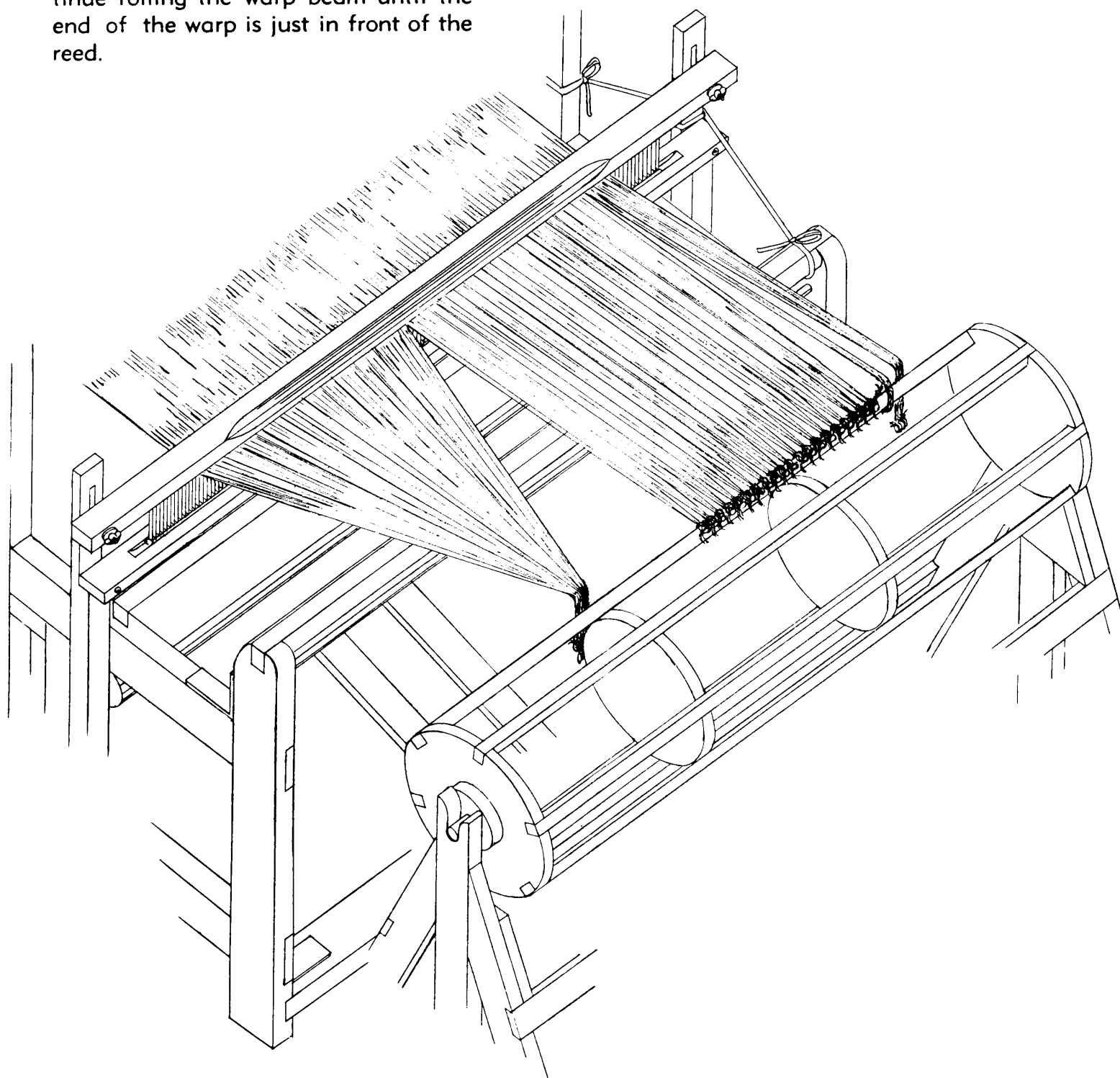

E. TYING WARP TO CLOTH APRON

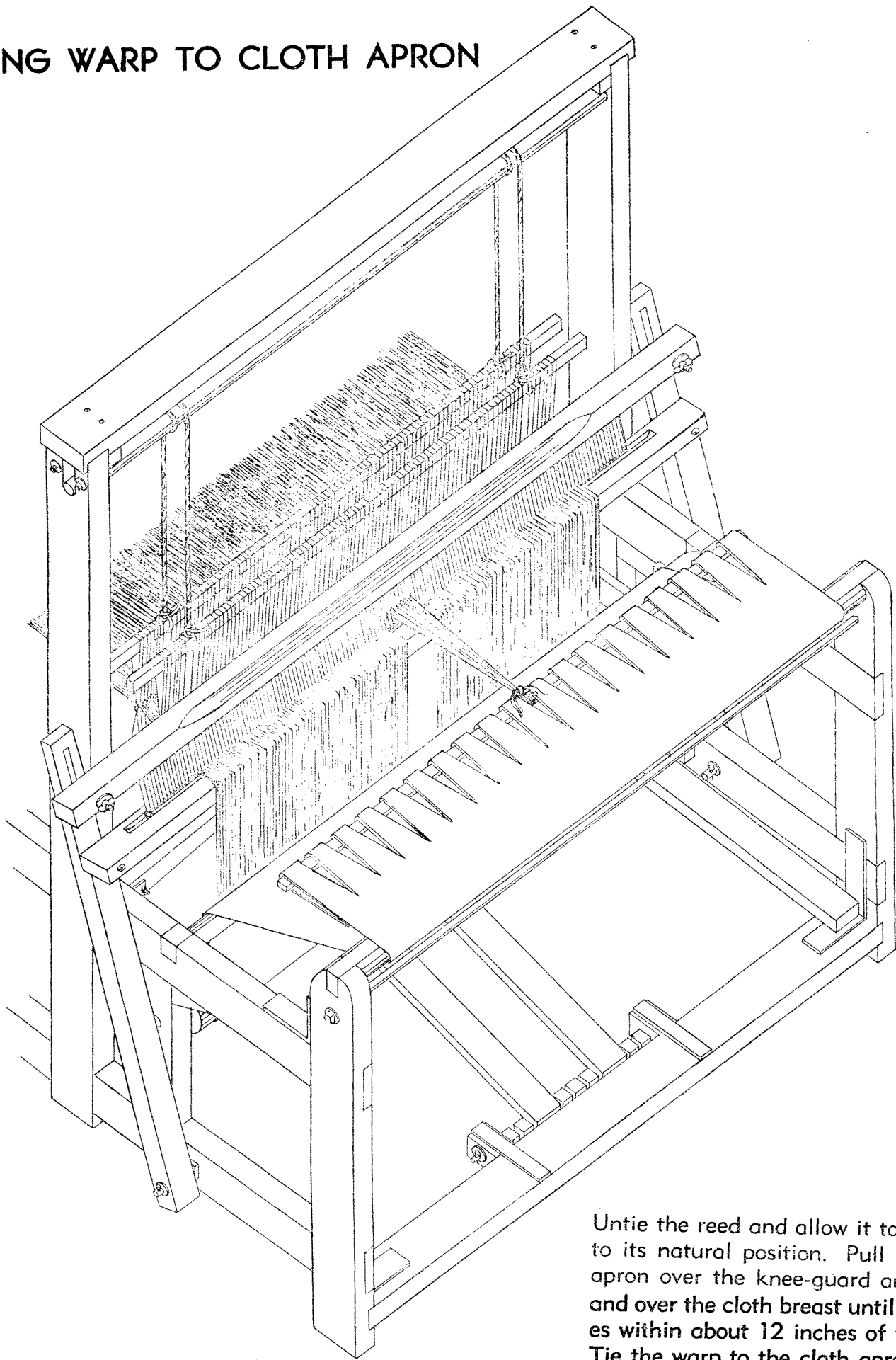

Untie the reed and allow it to go back to its natural position. Pull the cloth apron over the knee-guard and under and over the cloth breast until it reaches within about 12 inches of the reed. Tie the warp to the cloth apron in exactly the same way that you tied it to the warp apron.

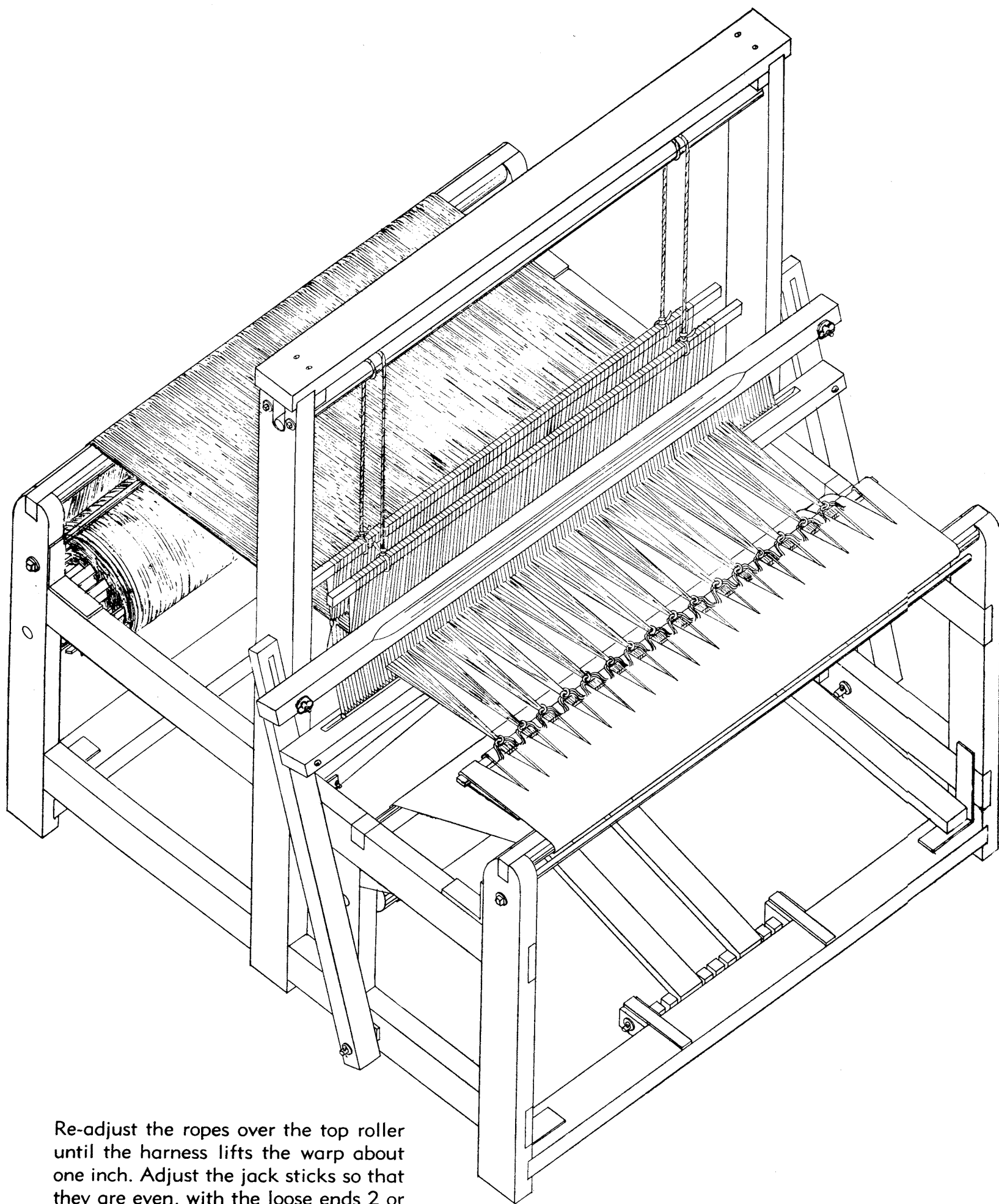

Re-adjust the ropes over the top roller until the harness lifts the warp about one inch. Adjust the jack sticks so that they are even, with the loose ends 2 or 3 inches below the harness. The loose ends of the pedals should stand about 9 or 10 inches from the floor or high enough that they will not strike the floor when pressed down.

5. WEAVING

A. MOVING THE WARP

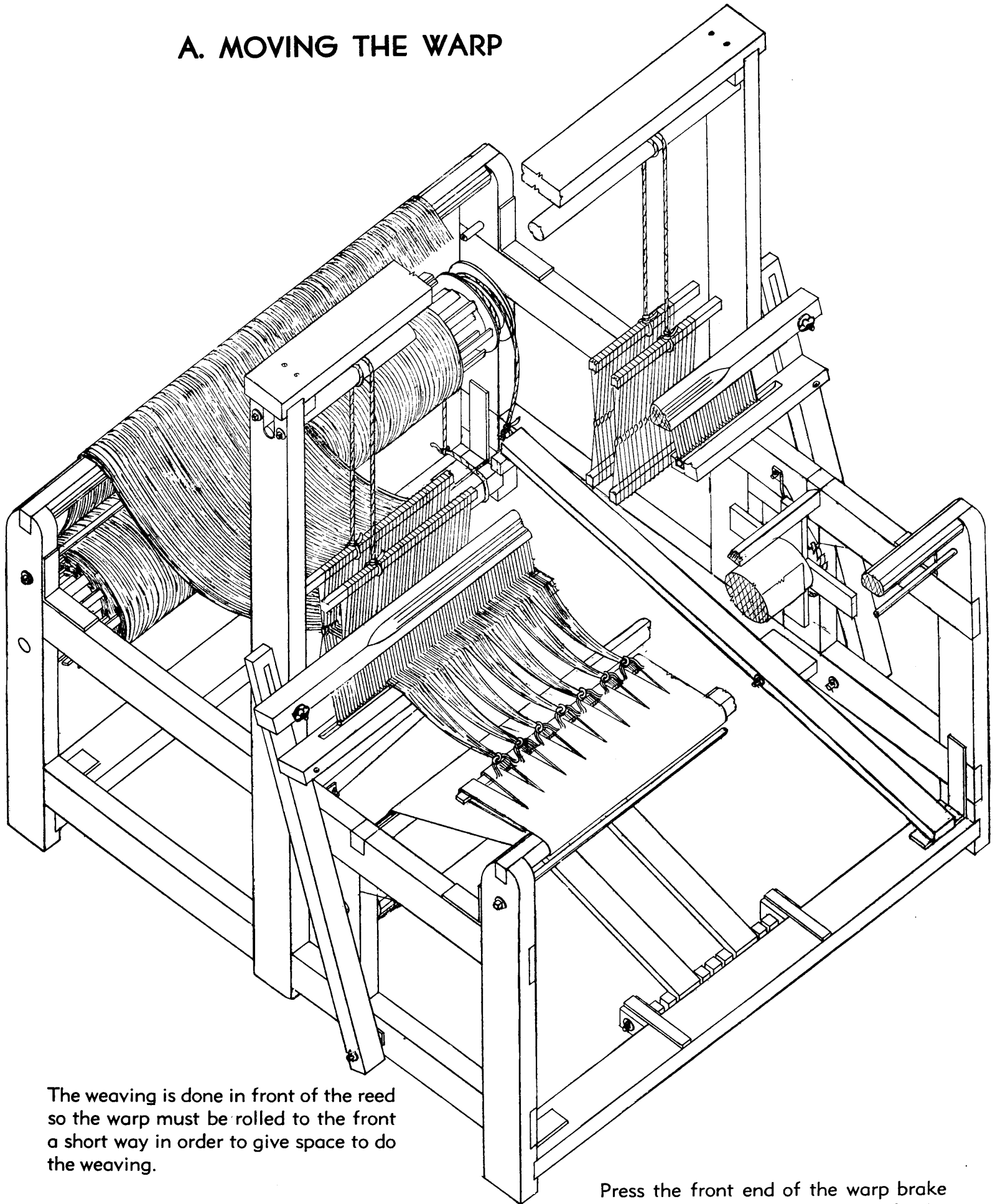

The weaving is done in front of the reed so the warp must be rolled to the front a short way in order to give space to do the weaving.

Press the front end of the warp brake down with your right foot. This lifts the weight on the other end of the brake and allows the warp beam to roll for-

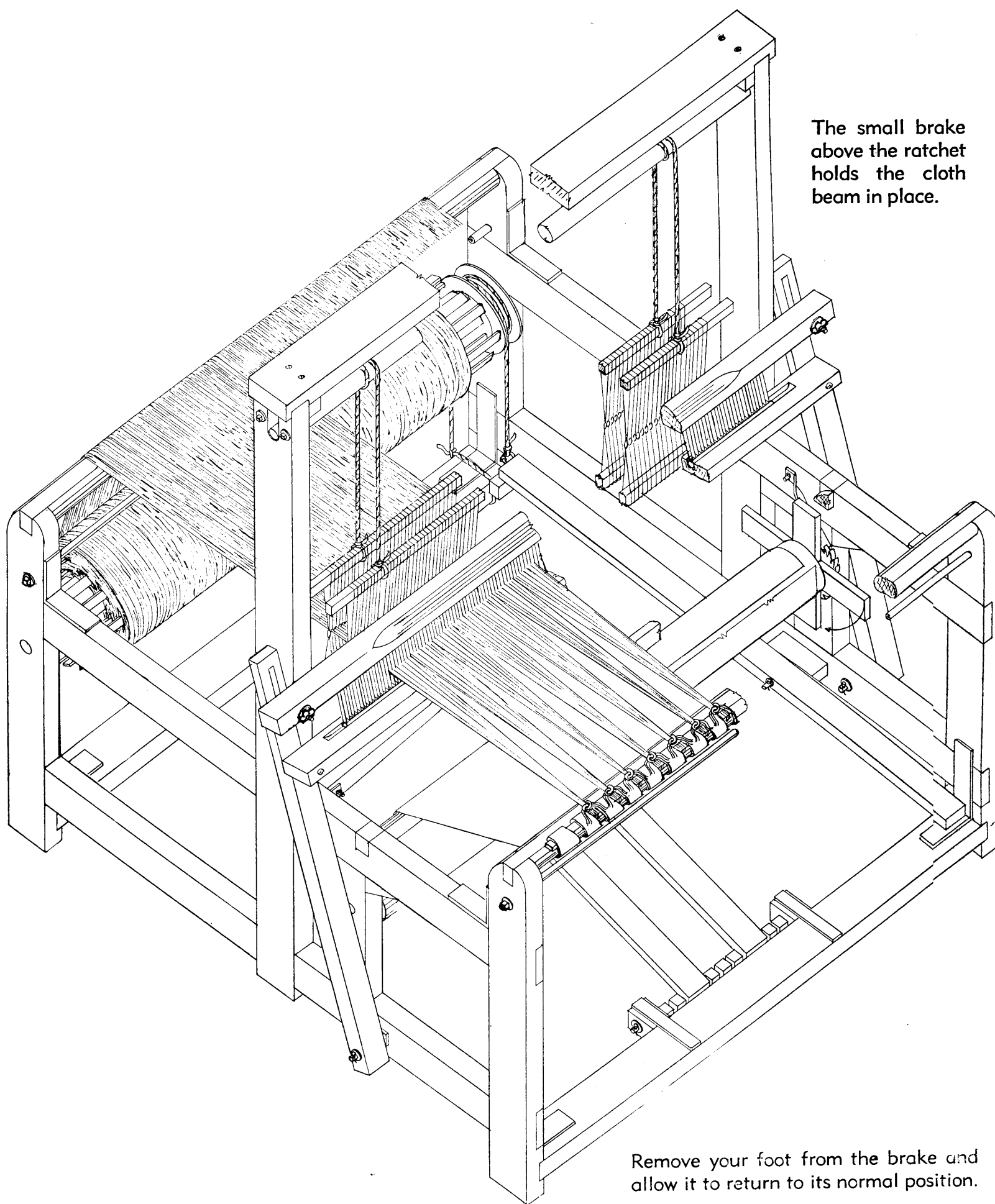

The small brake above the ratchet holds the cloth beam in place.

The warp should be stretched firmly while you are weaving. You should keep the same amount of tension on the warp throughout the weaving of one piece.

Remove your foot from the brake and allow it to return to its normal position.

Turn the cloth beam forward with your right foot until the warp is taut or tight again.

B. OPERATING THE LOOM

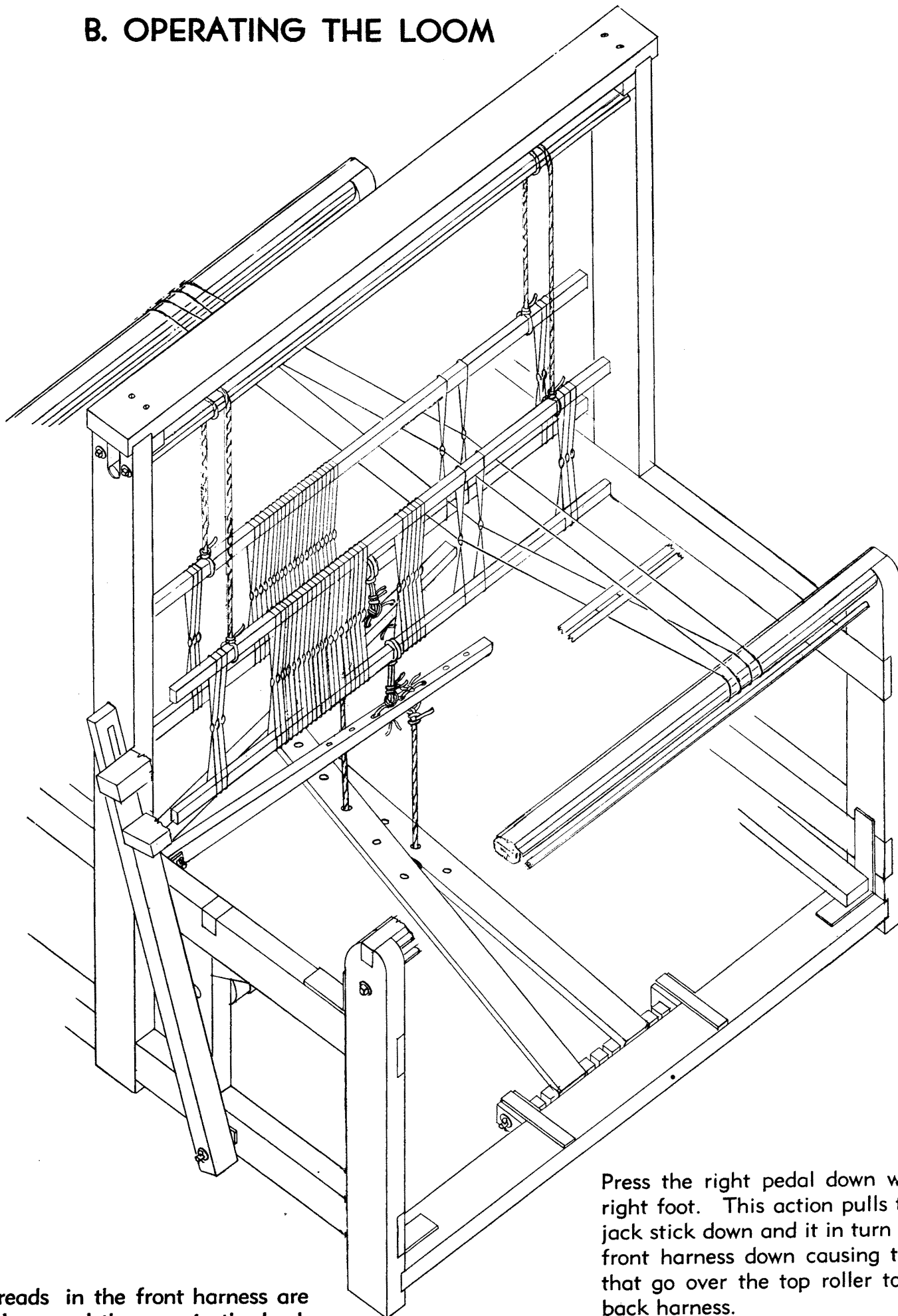

The threads in the front harness are pulled down and the ones in the back harness are lifted.

Press the right pedal down with your right foot. This action pulls the front jack stick down and it in turn pulls the front harness down causing the ropes that go over the top roller to lift the back harness.

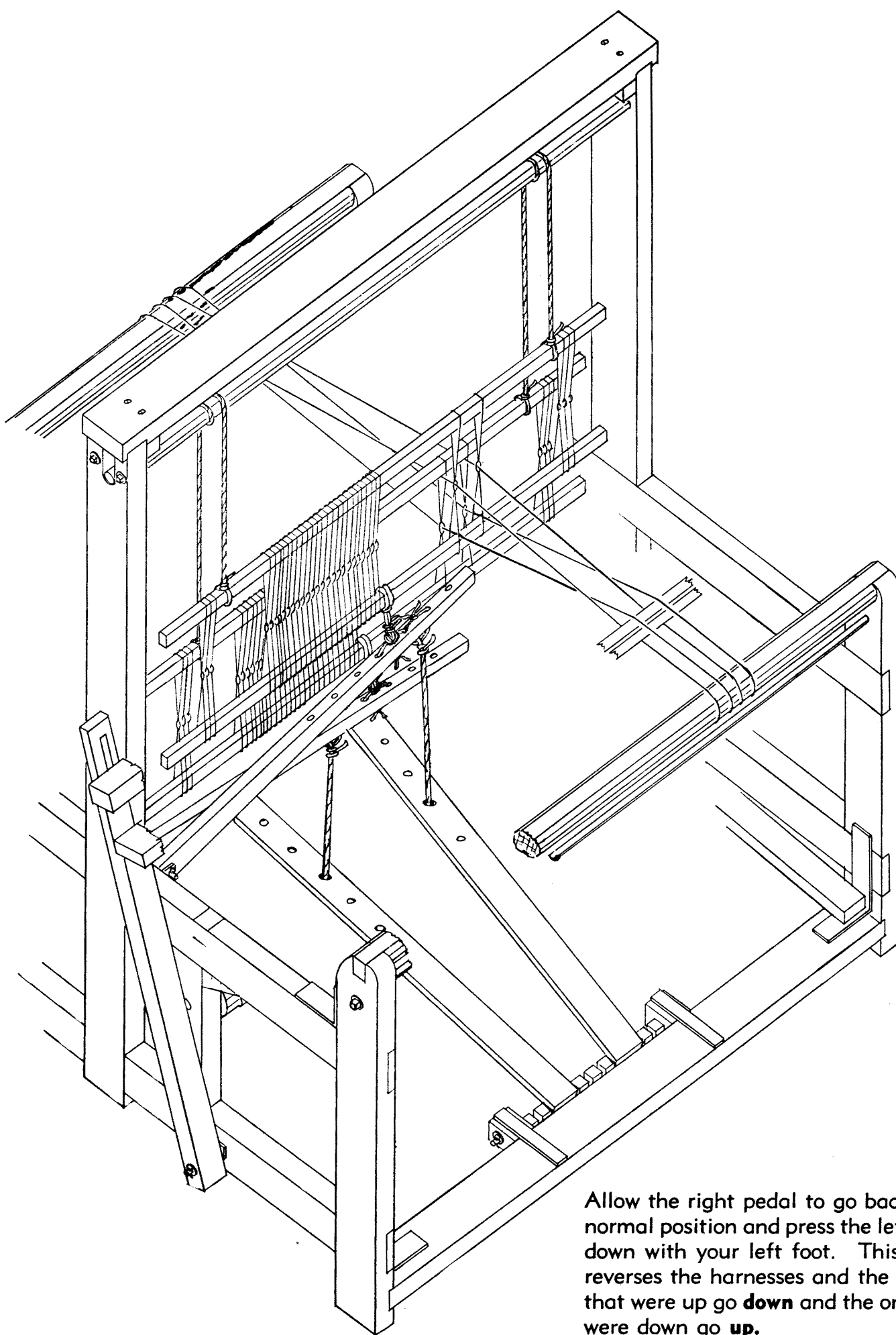

Allow the right pedal to go back to its normal position and press the left pedal down with your left foot. This action reverses the harnesses and the threads that were up go **down** and the ones that were down go **up**.

Wind a large rug shuttle with 5 or 6 yards of wide carpet rag strips. Two strips can be wound together to make a heavy roll for the first few fillers.

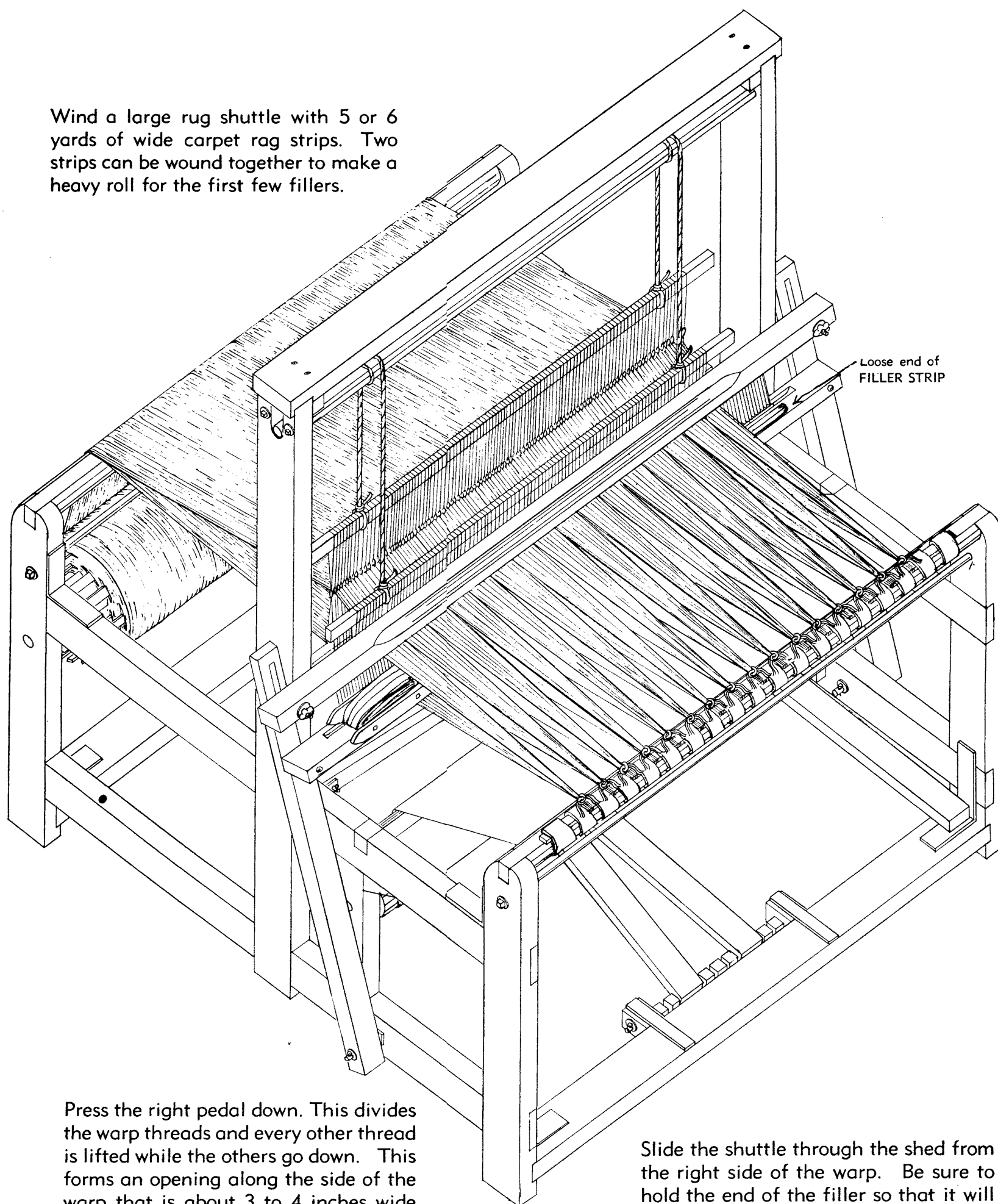

Press the right pedal down. This divides the warp threads and every other thread is lifted while the others go down. This forms an opening along the side of the warp that is about 3 to 4 inches wide just in front of the reed. This opening is called a shed.

Slide the shuttle through the shed from the right side of the warp. Be sure to hold the end of the filler so that it will stay 2 or 3 inches beyond the edge of the warp.

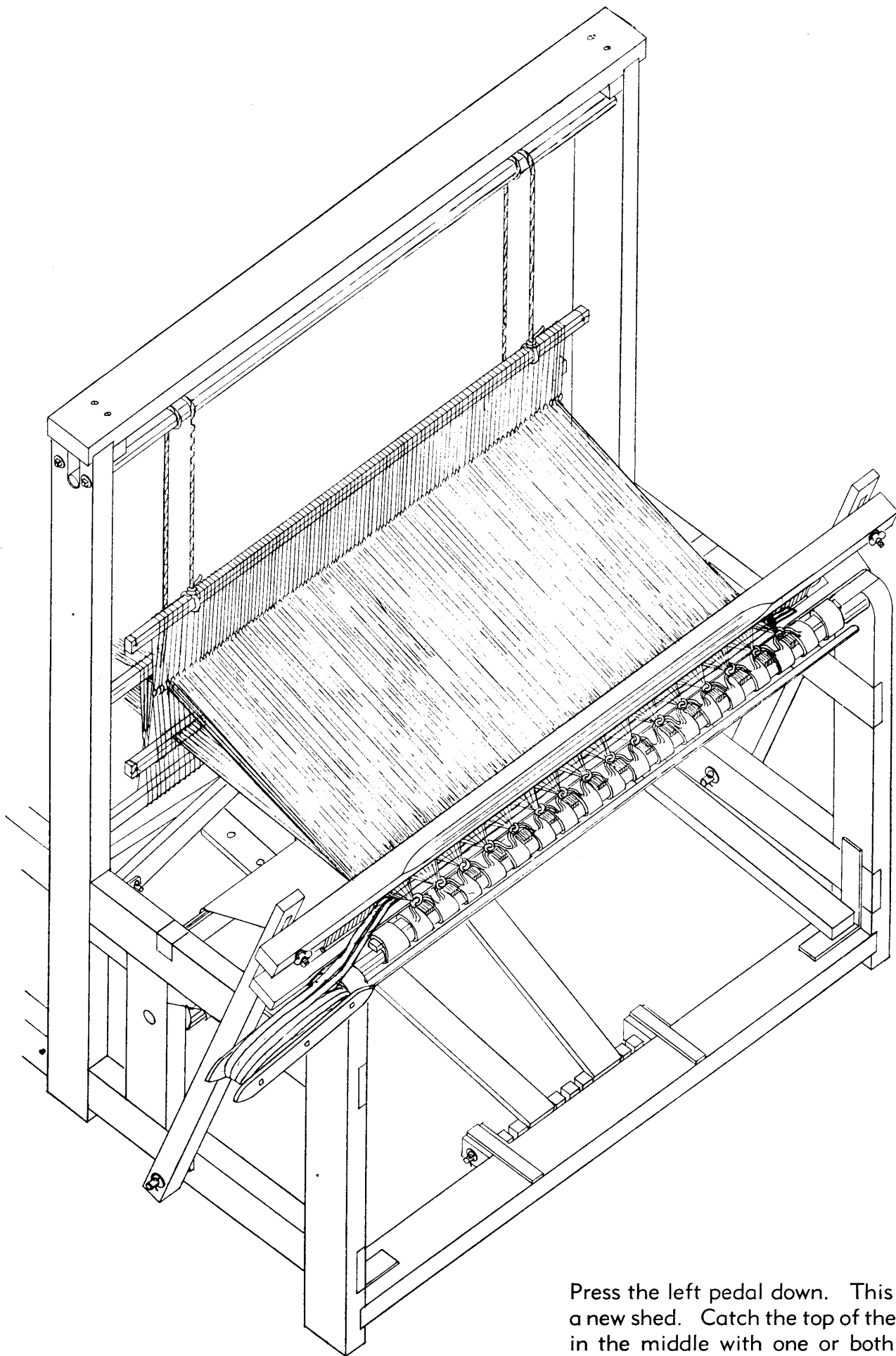

Press the left pedal down. This makes a new shed. Catch the top of the beater in the middle with one or both hands and carefully pull it forward until the filler is drawn down near the knots.

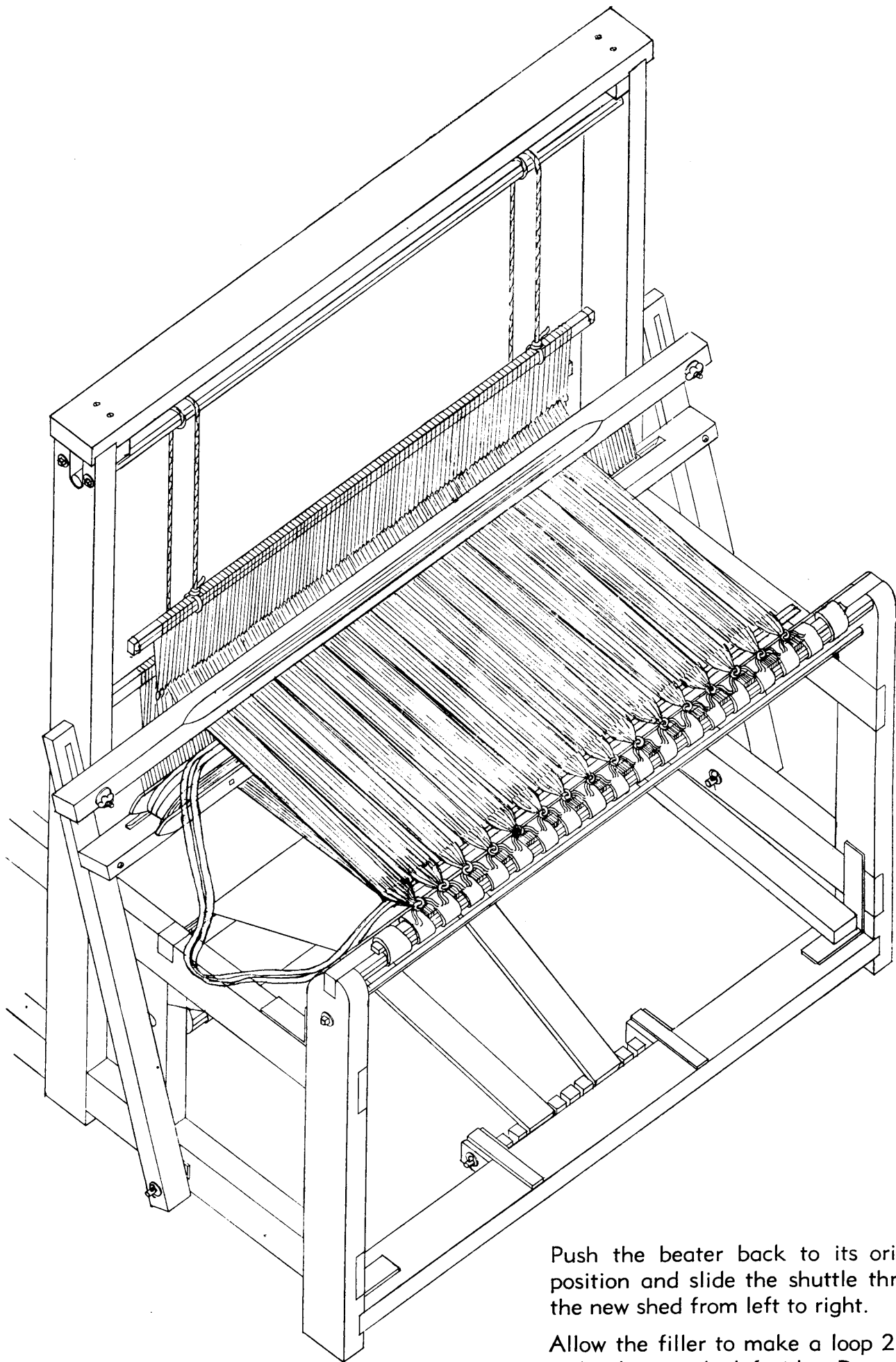

Push the beater back to its original position and slide the shuttle through the new shed from left to right.

Allow the filler to make a loop 2 or 3 inches long on the left side. Do not pull the filler tight as this will pull in the edges of the warp.

C. SPREADING THE WARP

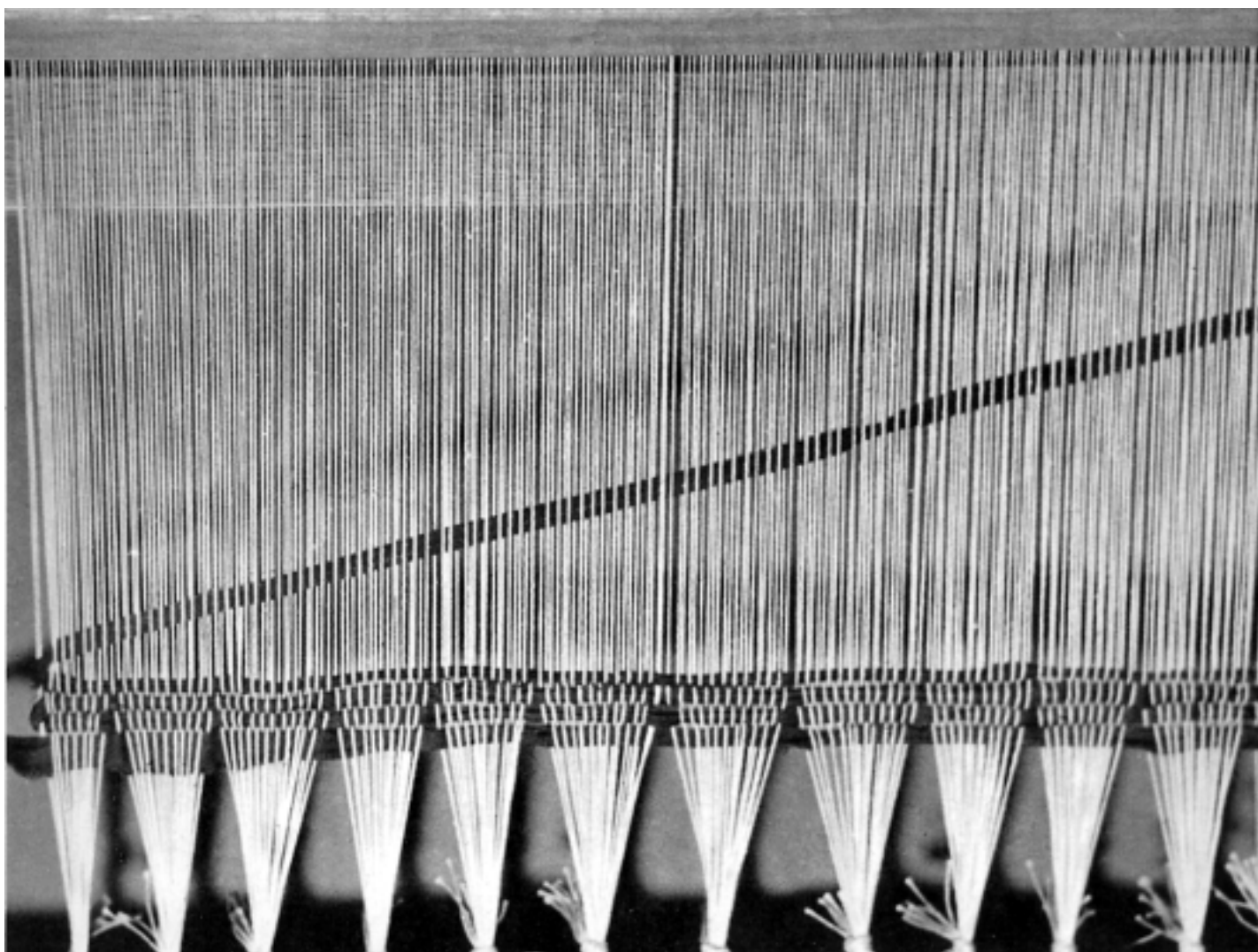

Change the shed by again pressing the right pedal down and allowing the left one to come up. Bring the beater forward until the second filler touches the first one. Continue weaving by repeating the steps of putting in the filler, changing the shed by pressing the other pedal and pulling the filler into place with the beater until the warp threads are evenly spread and are no longer divided into groups. Use 5 or 6 rows of this heavy filler before starting the shawl in order to spread the warp evenly and to its **full width**. This spreading is very important in starting a new piece of weaving.

D. WINDING A BOBBIN

The filling yarn is wound on a bobbin. You can weave faster by using a small rug shuttle or a boat shuttle on wide materials. The small rug shuttle is best for heavy yarn while the boat shuttle is best for fine yarn but either one can be used for medium weight yarn.

Place your skein or ball of yarn on the skein spreader while winding the bobbins.

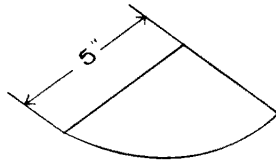

To wind the bobbin for a boat shuttle, cut a paper about 5 inches square and round off one corner.

Fasten the bobbin winder onto a table.

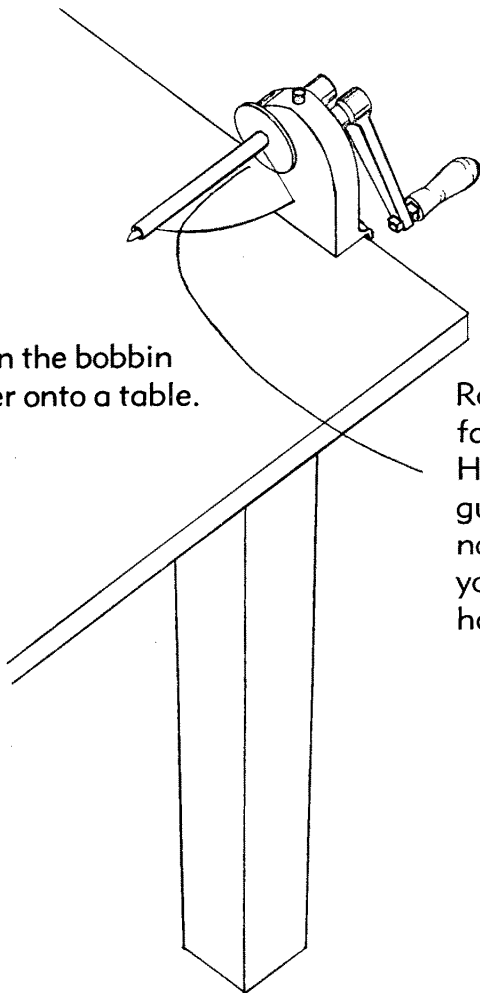

Roll the paper around the spindle and fasten with the end of the filling thread. Hold the yarn firm in the left hand and guide it back and forth, being careful not to reach the ends of the paper as you turn the winder with your right hand.

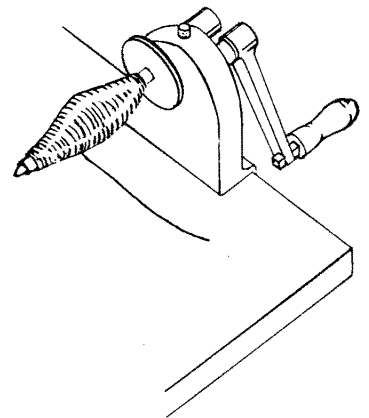
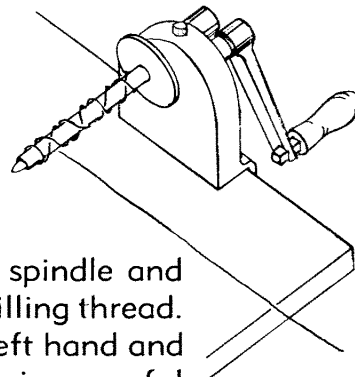

When the bobbin is about 1½ inches in diameter in the center, break the yarn and slip the bobbin off the spindle.

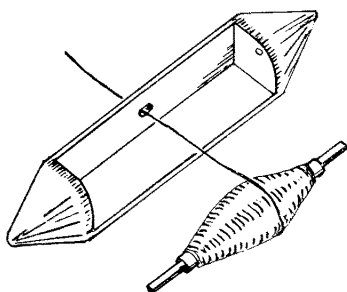

Place a small bamboo stick or spring wire through the paper core and thread the end of the yarn through the eye of the shuttle. Place the ends of the stick in the small holes in the shuttle.

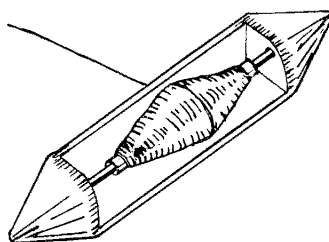
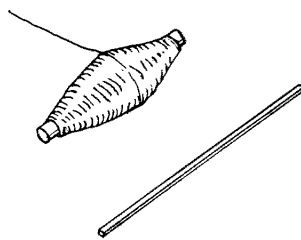

Turn the shuttle around so that the solid side is next to you while weaving.

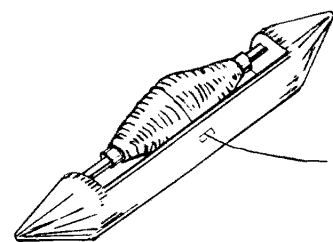

STARTING THE SHAWL

Wind a small bobbin for a boat shuttle with yarn like the warp, using the same color that is on the right side of the warp. Open one shed and slide the shuttle through. Allow the end of the filling yarn to stop about the middle of warp. Never let the end of a filling thread hang beyond the selvage. Change the shed and continue weaving just as you did with the heavy carpet rags in the beginning.

You can get many different effects by the way you pull the filling thread into place. If it is pounded into place with force, the material will be stiff and firm. If you pull it up gently and leave a space between each filling thread, the material will be loose, soft, and quite pliable. There is a great variety between these two extremes. Select the spacing for the filling threads that is most suitable for the article you are weaving. Keep this spacing throughout the entire length of the article.

The shawl that we are making should have the filling threads spaced so that 12 or 13 threads fill one inch. They should be about the same distance apart as the warp threads.

Weave with the first color until the crosswise stripe is the same width as the stripe on the right hand side of the warp. If this is a wide stripe it may take a few more threads in the filler than you used in the warp. It is better to measure the wide stripes rather than to count the threads in them, otherwise the block of solid color may not be a perfect square.

When you have completed the first stripe, break or cut the filling thread so that the end will be somewhere between the edges of the warp. This may be in the middle or near one side but never allow it to end exactly at the edge. Fill another little shuttle or bobbin with the color of the second stripe in the warp. Start the new thread in the same shed in which the old one ended, and allow the ends to cross 1 to 2 inches. (See Page 81). Make this stripe the same width as the second one in the warp. Continue changing colors using the stripes in the warp as a pattern. This crossing of the same width stripes will give you an even plaid. By changing the size and arrangement of the filling stripes you can get a variety of different plaids.

You can make a lengthwise striped pattern by using only one color for the filler. If the warp is all of one color, crosswise stripes can be made by changing the colors of the filler.

Continue weaving on the shawl until the space in front of the reed becomes too narrow to allow the shed to be open its full width. Roll the warp forward exactly as you did on pages 65 and 66.

When you have finished one shawl, roll the warp forward several inches, open the shed and place in the first thread of the second shawl. Pull this filling thread down with the beater until it comes to within 11 inches of the first shawl and continue weaving as before. This space between the shawls is for the fringe. It is not necessary to use extra filling threads in this space.

E. STARTING THE SHAWL

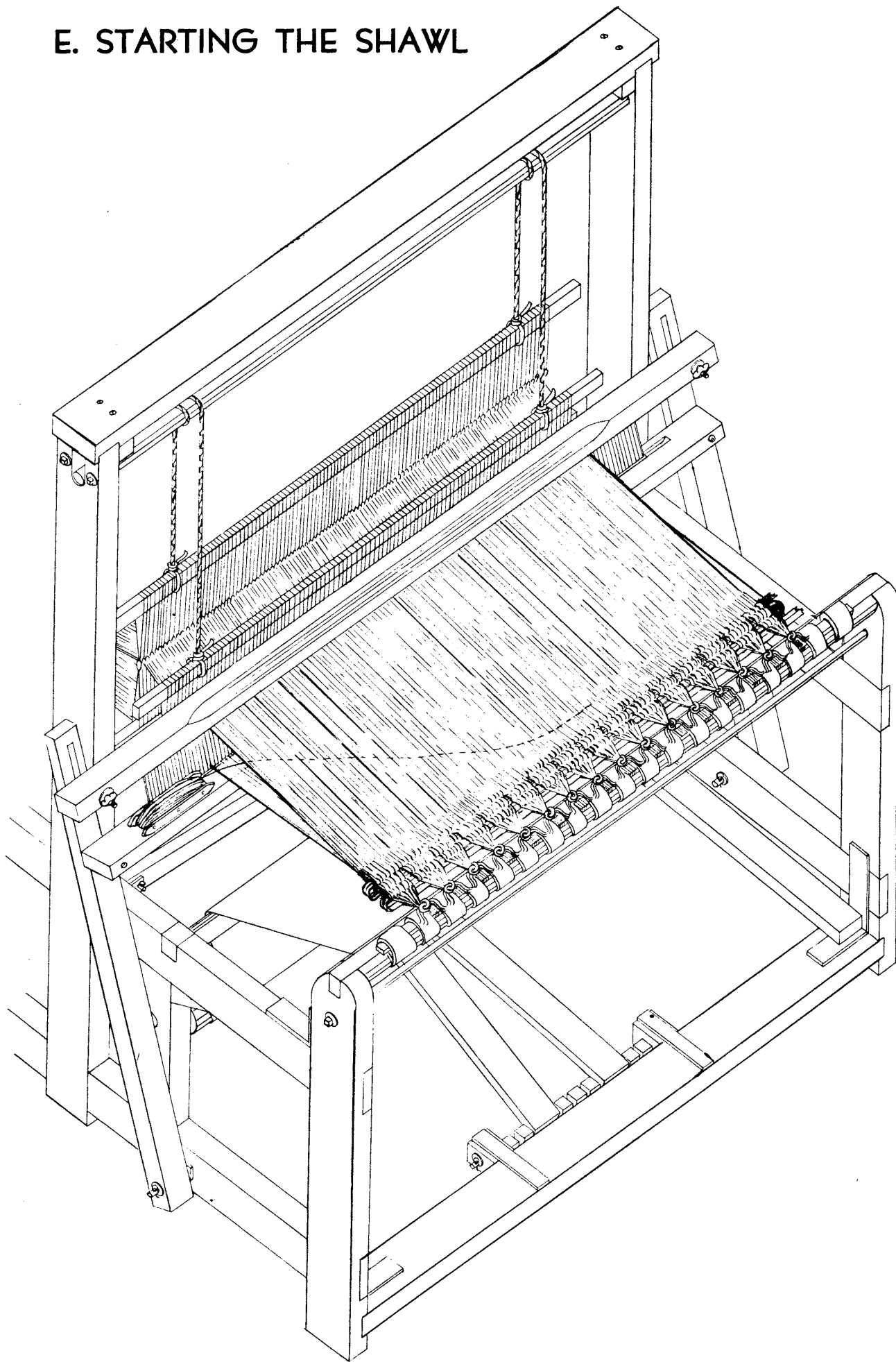



There are several important things to remember while weaving in order to make a beautiful piece of material. A woven article should be the same width for its entire length and should have straight, even selvages. It is easy to avoid making loops or pulled in places along the edges. In the first place, be sure to start the woven part the same width that the warp is set in the reed. Each time that a filling thread is put in, let it turn directly around the out-

side selvage thread and place it at an angle to the line of weaving (page 79) The "line of weaving" is the last filling thread that has been pulled into place. With the filling thread in this angling position, catch each side of the woven part and stretch it crosswise and hold it until you have changed the shed. With a little practice you can master these simple steps and can keep your weaving the same width and make straight, even edges.



Another important thing is the spacing of the filling threads. They should be exactly the same distance apart throughout one piece. Pull each filling thread into place with the beater using the same amount of pressure each time.

Be sure that the tension of the warp is the same throughout the weaving. When you leave the loom for several hours or over night, loosen the warp threads and then tighten them again when you are ready to weave.



ADJUSTING THE LOOM

Sometimes the shed does not open correctly. This may be caused by one of several things. First check to see if any of the threads are crossed between the reed and the harnesses. (See page 52). Next check the tying up of the loom to see that the harnesses, jack sticks, and pedals are at the right height. It is easy to get the harnesses a little too high, making it impossible to open one of the sheds. Sometimes lint on the warp prevents the shed from opening correctly. Pulling the beater back to the line of weaving will often times help to open the shed. If this

fails remove the lint with your fingers. If one thread is higher or lower than the others, check to see if there is an imperfect heddle. If a heddle knot has slipped, cut out the heddle and tie in another one.

If warp threads next to each other raise or lower at the same time, you have made a mistake in threading the harness. If the space between two warp threads is too wide, or too narrow, a mistake has been made in threading the reed. **All mistakes** should be corrected as soon as they are found, if not, they will always show in the finished piece.

F. WEAVING THE SHAWL

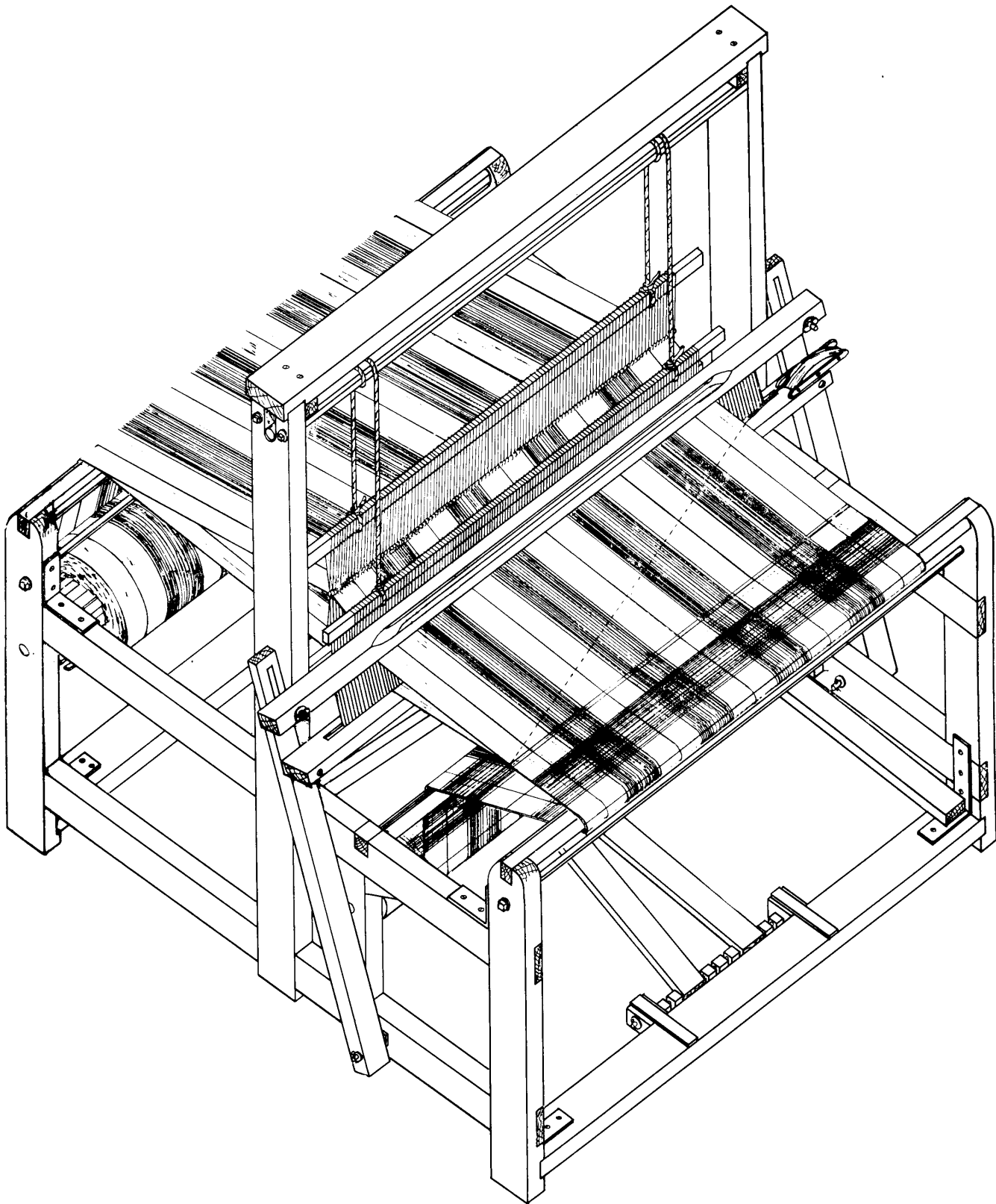

6.
**COMPLETING THE ARTICLE AND
VARIOUS THREADINGS**

A. STARTING A NEW FILLING THREAD

Cut the old filling thread so that the end will come somewhere between the edges of the warp.

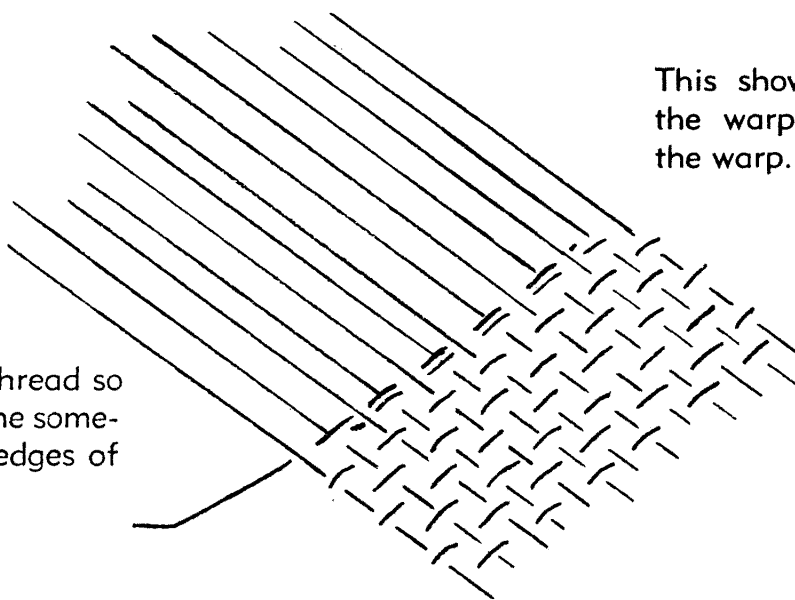

This shows a section in the middle of the warp and is not the full width of the warp.

Place the new thread in the same shed in which the old one ended and let the two ends cross $1\frac{1}{2}$ to 2 inches.

Continue weaving as before. Clip the loose ends closely. These crossed places are not noticeable in the finished pieces.

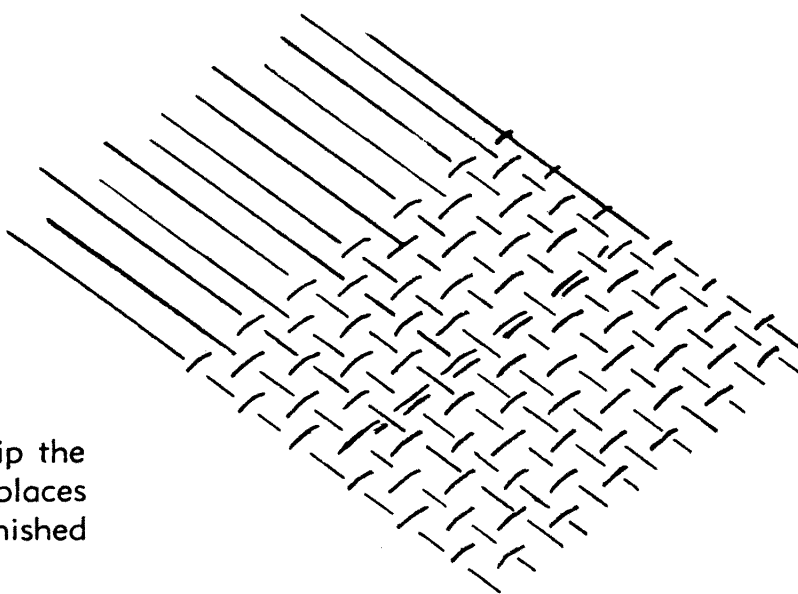

B. PIECING A BROKEN WARP THREAD

Sometimes a warp thread breaks or a knot needs to be removed. Pull the broken ends out of the reed and harnesses.

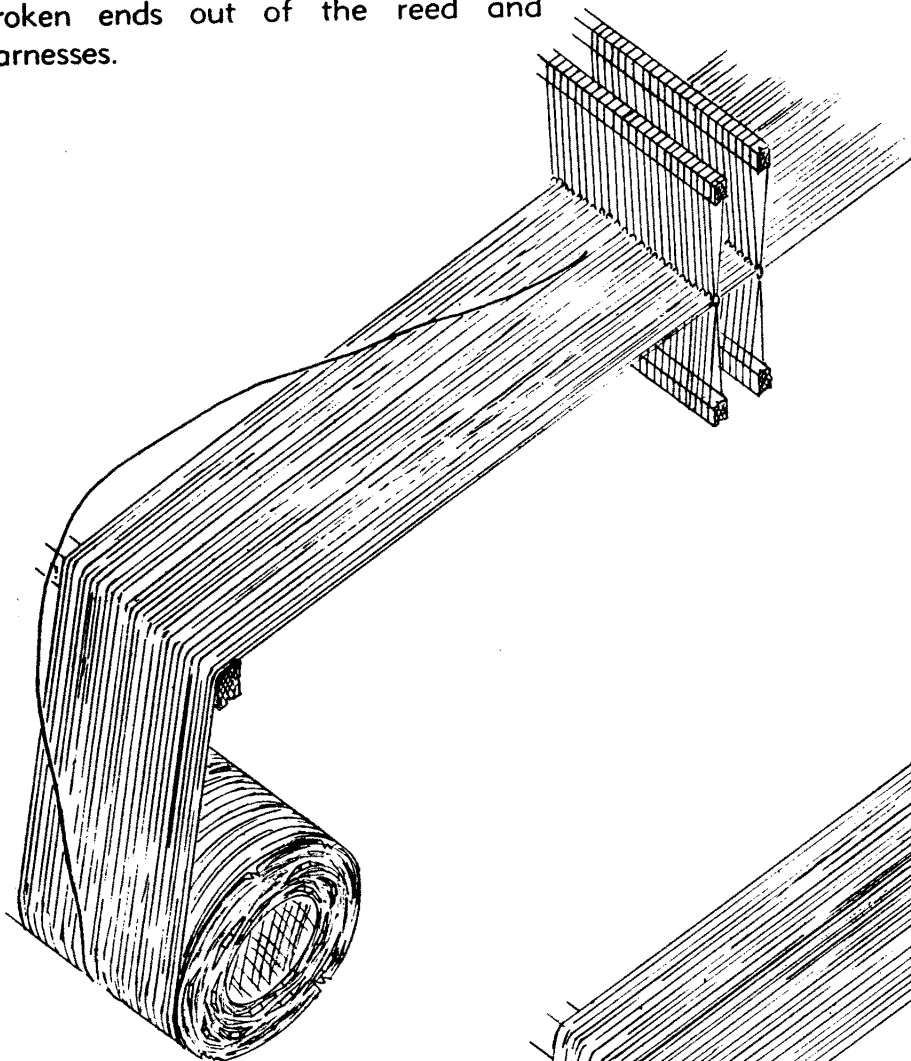

Take a new piece of warp $1\frac{1}{2}$ or 2 yards long and thread it through the same heddle and dent.

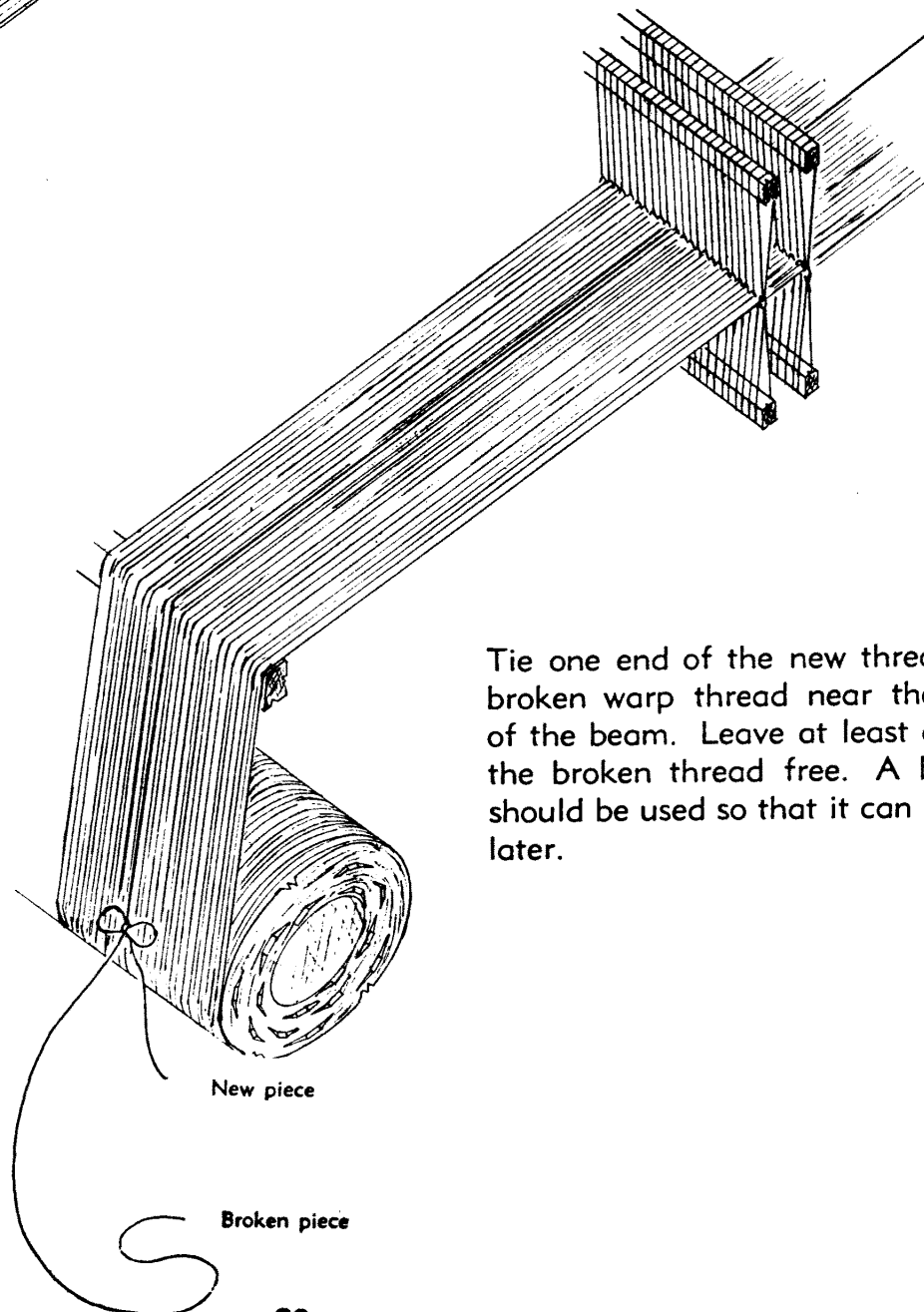

Tie one end of the new thread to the broken warp thread near the bottom of the beam. Leave at least a yard of the broken thread free. A bow knot should be used so that it can be untied later.

From the front of the loom pull the other end of the new thread up until the tension equals that on the other warp threads and fasten it a few inches below the line of weaving with a pin.

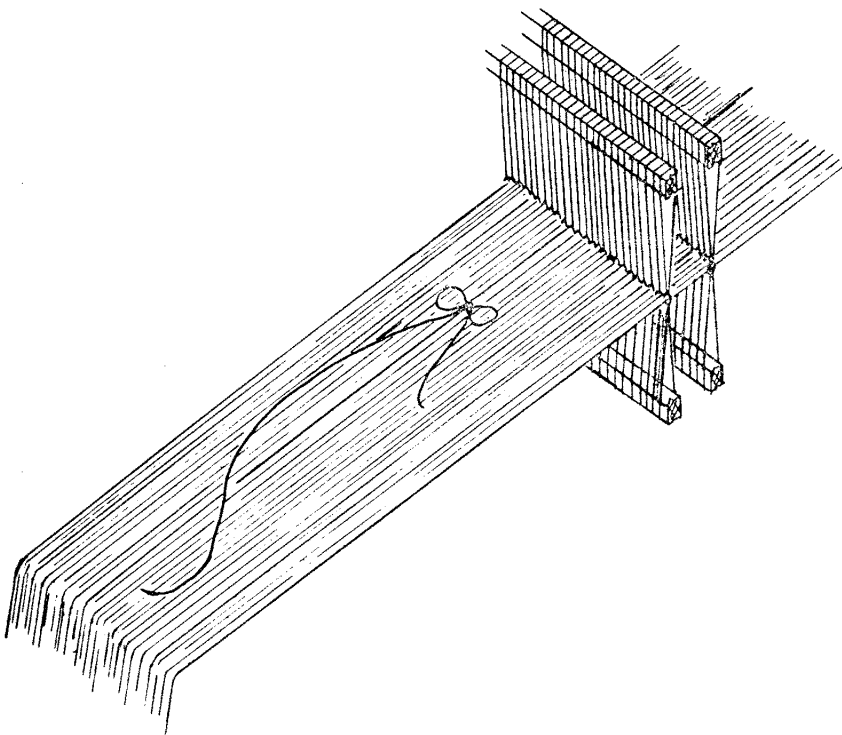
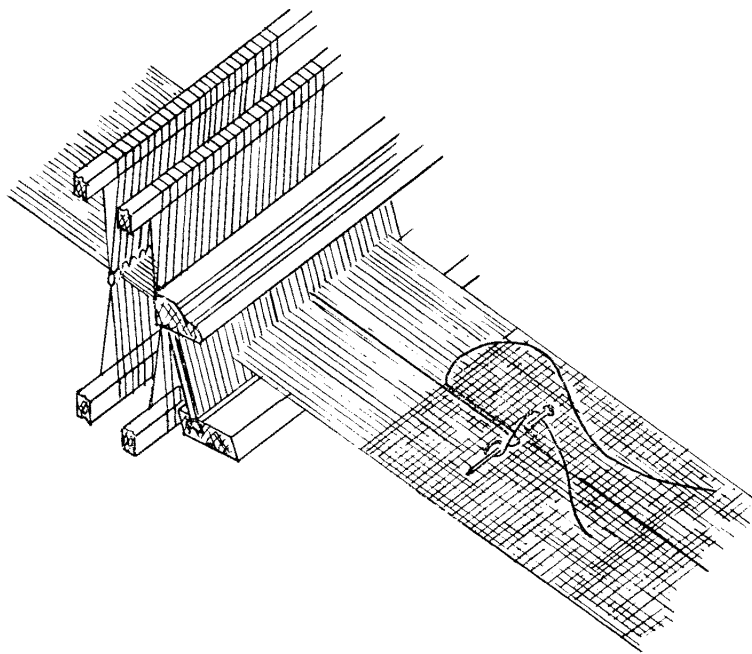

Continue weaving until the bow knot comes above the warp breast.

Untie the bow knot and tie the ends together in a square knot (pages 20 and 21). From the front side pull the thread until the knot comes through the reed. Cut out the knot and pin the old thread in place.

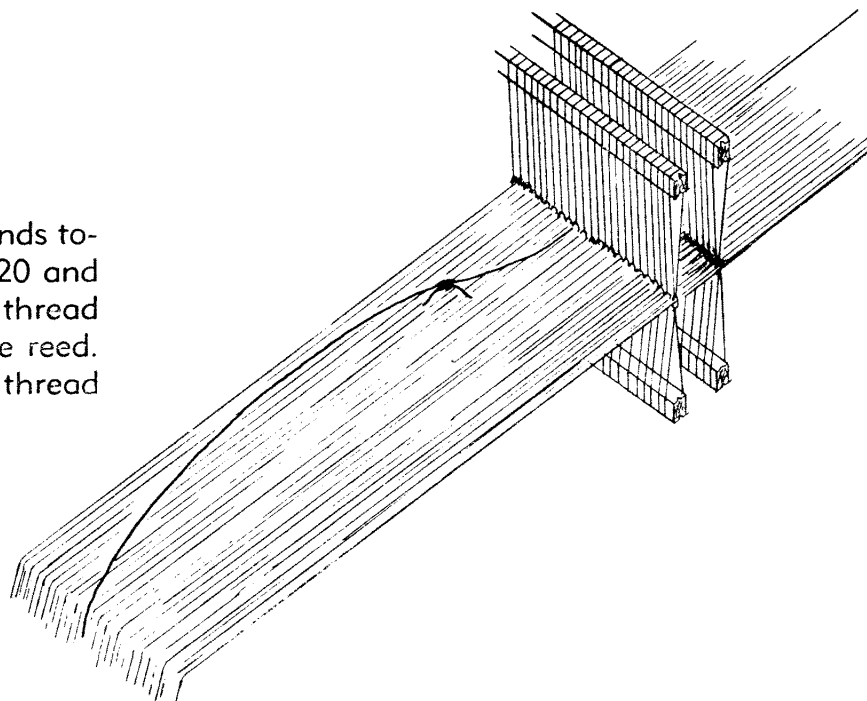

After several inches have been woven or after the material has been taken out of the loom, the imperfect places should be mended.

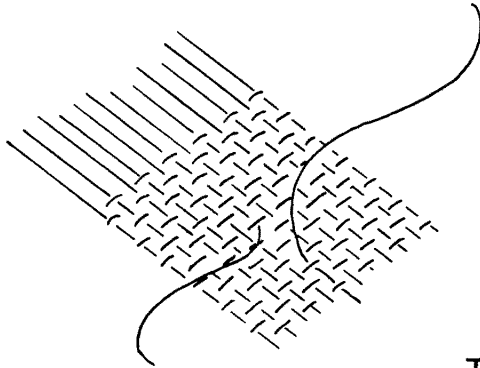

Thread one of the loose ends in a blunt needle and weave over and under the filling threads following the other end of the same warp thread.

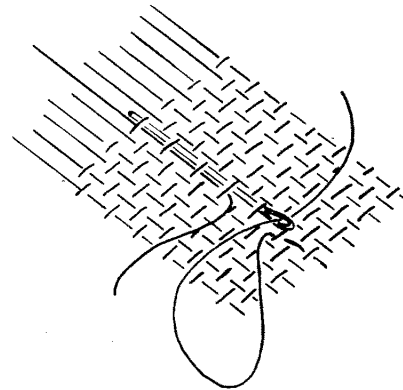

The two ends should be lapped 1 to 2 inches. Clip off the long ends. There should be no knots in either the warp or the filler in a shawl of this kind. All spliced places should be lapped.

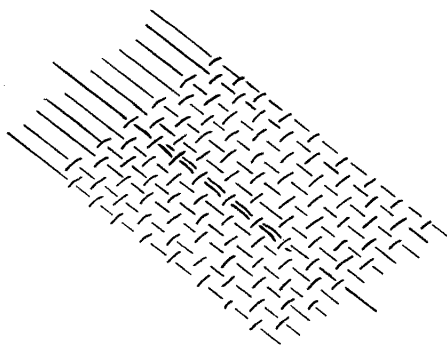



REMOVING THE MATERIAL FROM THE LOOM

When you have reached the end of the warp on the loom, untie the knots on the warp apron and carefully pull the ends through the harnesses and the reed. Fold the ends back over the woven material. Unroll the material from the cloth beam and wind it into a roll. Untie the knots on the cloth apron and carefully fold in the loose ends. Keep the shawls rolled until you are ready to finish them.

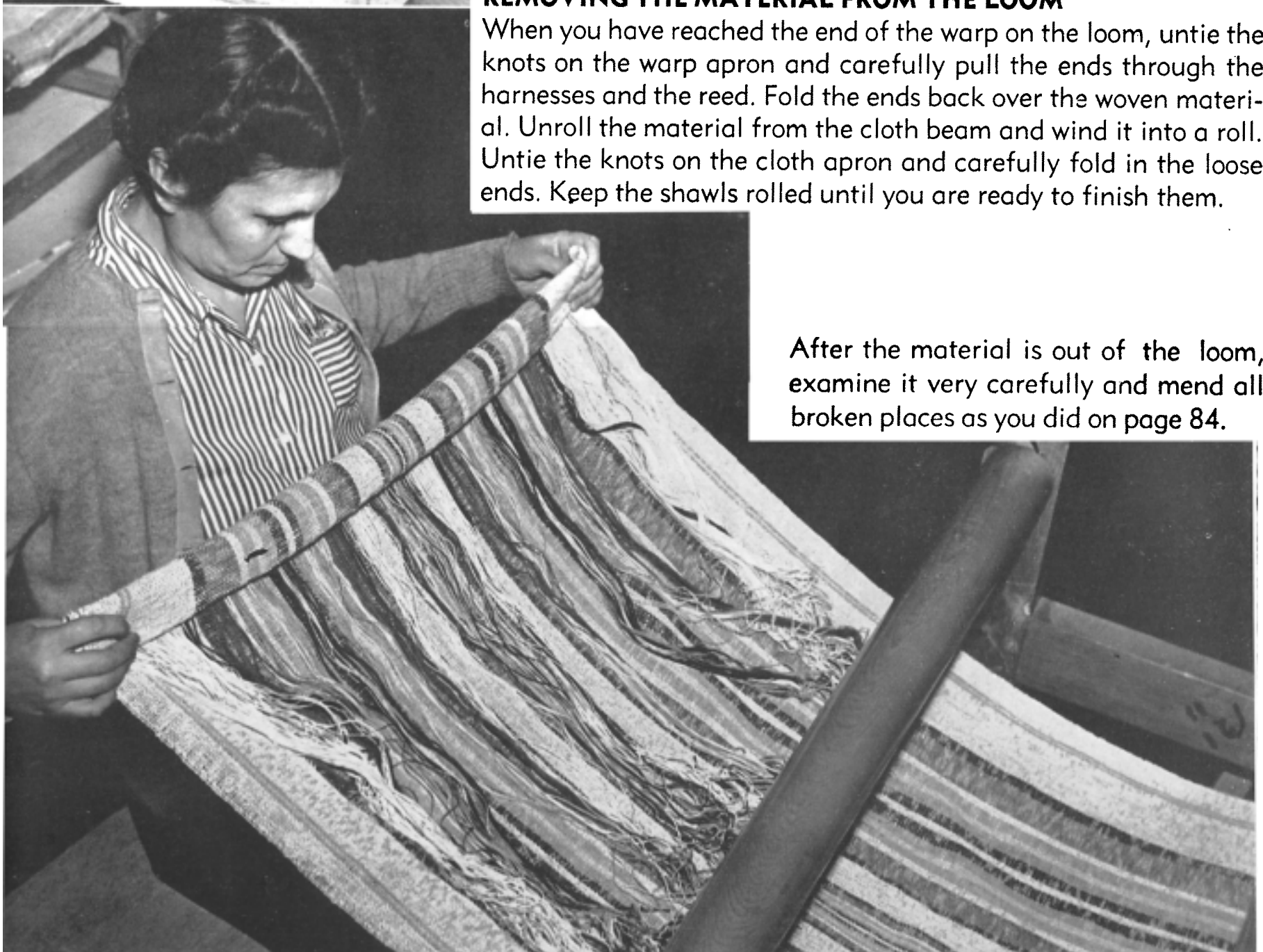

After the material is out of the loom, examine it very carefully and mend all broken places as you did on page 84.

C. FINISHING THE SHAWL

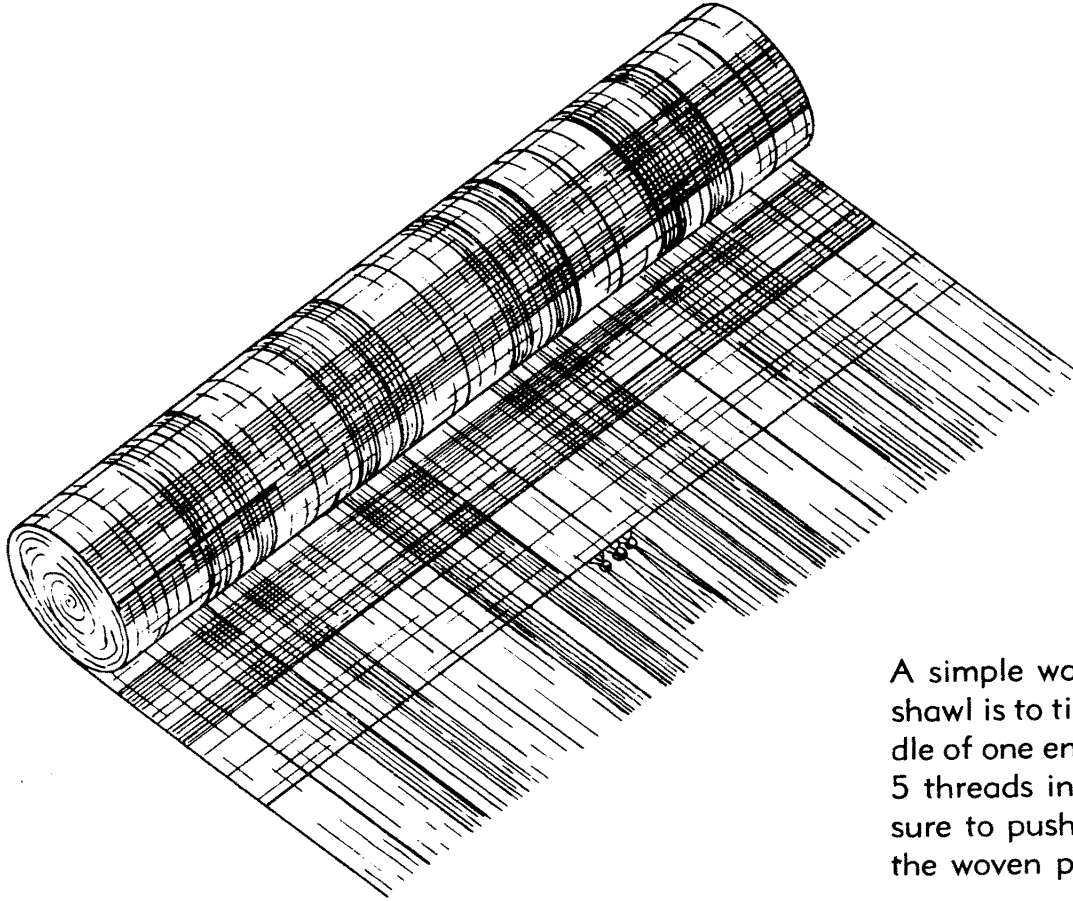

A simple way to finish the ends of a shawl is to tie a fringe. Start in the middle of one end of the shawl and use 3 or 5 threads in tying a simple knot. Be sure to push the knot up tight against the woven part.

From the center, tie knots across to the edges of the shawl. When one end is completed, unroll the shawl and cut the warp threads through the center of the 11 inch space that you left between the 2 shawls. Tie fringe across the other end of the shawl.

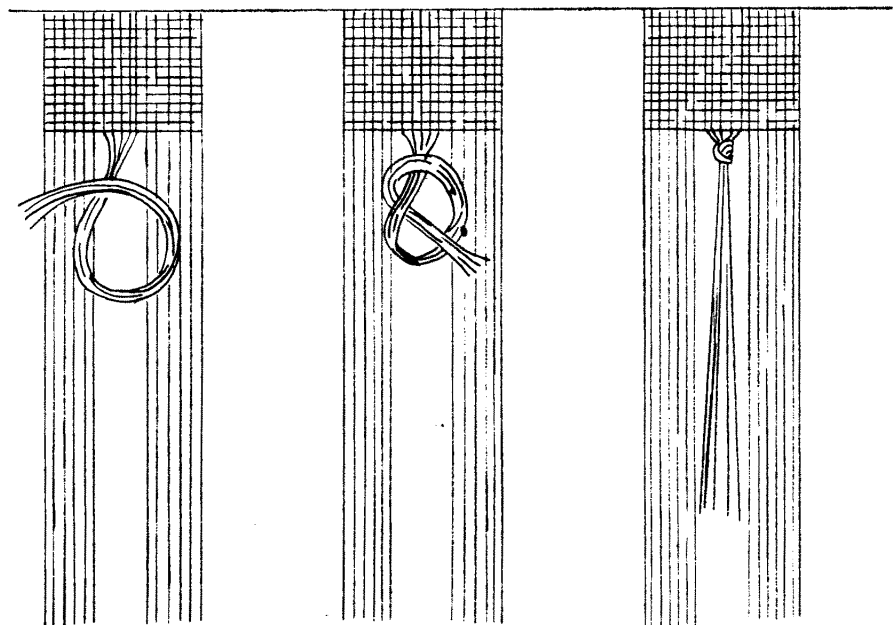

Most woolen material should be pressed with a damp cloth and a warm iron. The shawl will be much more attractive if you will press it in this way, going over the fringe as well as the woven part. After pressing, place one fringe on top of the other and trim the ends until both fringes are the same length.



Hand-woven yardage material can be made into jackets, coats, suits and dresses.



D. WHIPPING A FRINGE

On some of your woolen articles you may want to whip in the fringe rather than tie it. This is suitable for small table pieces, head scarfs, neck scarfs and many other articles. It is easier to whip the edge while the material is being woven than after it is taken out of the loom.

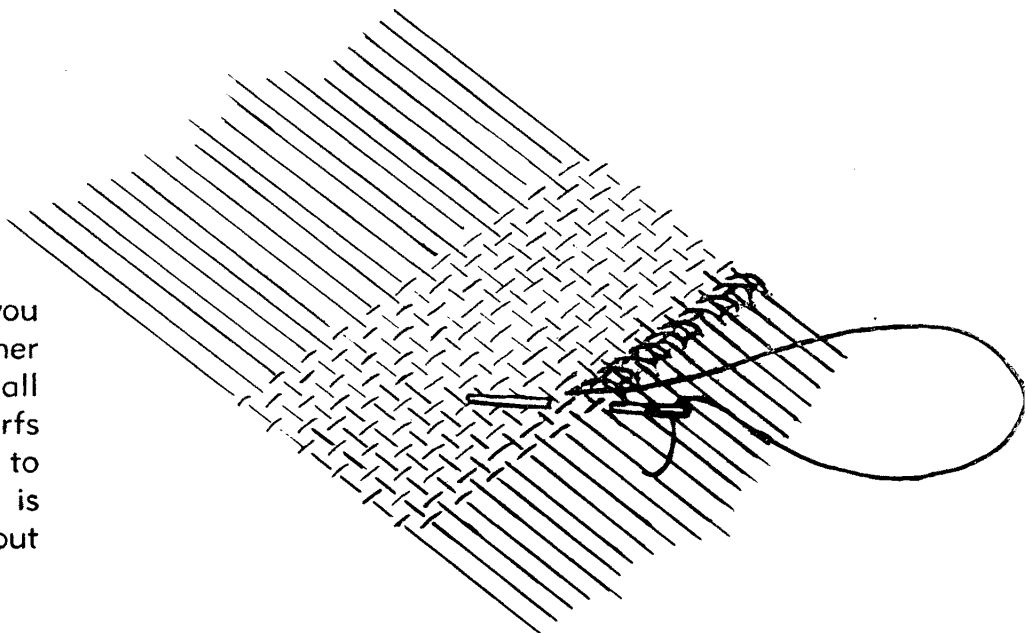

Weave about 2 or 3 inches on the article and then whip across the starting edge, using a piece of the filling in a large blunt needle. Catch each stitch across 2 or 3 filling threads.

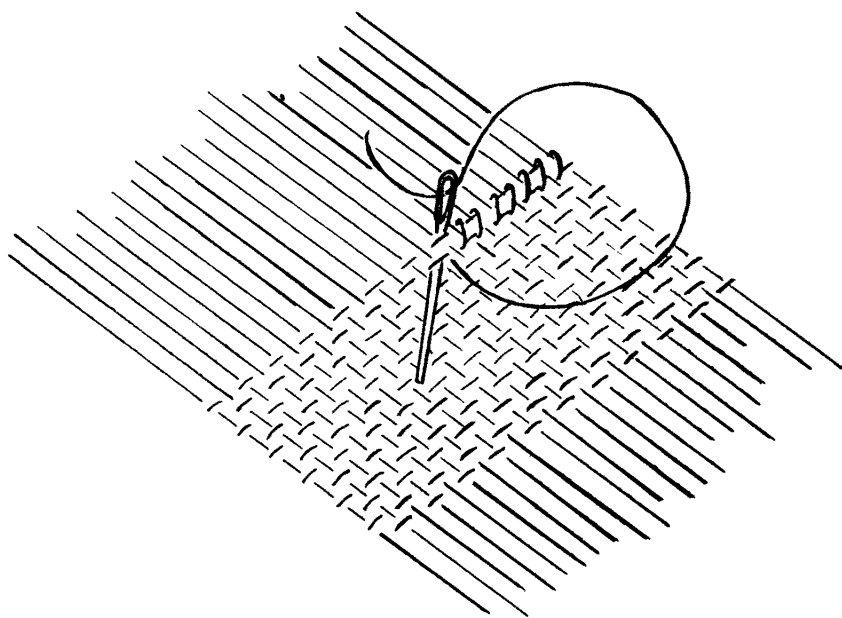

Complete the weaving and whip across the last end in the same way as you did the first end of the article.

E. DIFFERENT THREADINGS ON ONE REED

12 T (12 threads per inch)

You may want to weave materials that have more than 12 threads per inch or less than 12 threads per inch. A variety of threadings can be made on a number 12 reed. The next 8 pages give you a few samples.

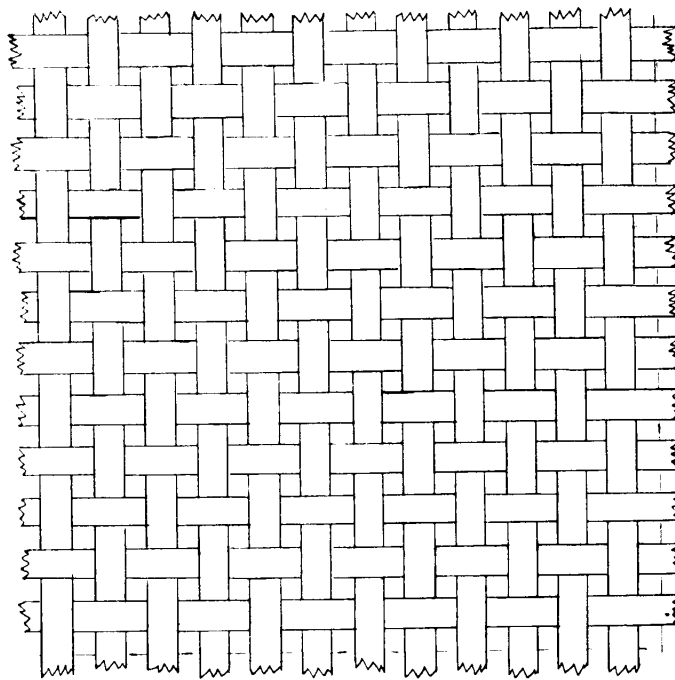

The big square above shows the pattern of one inch of woven material.

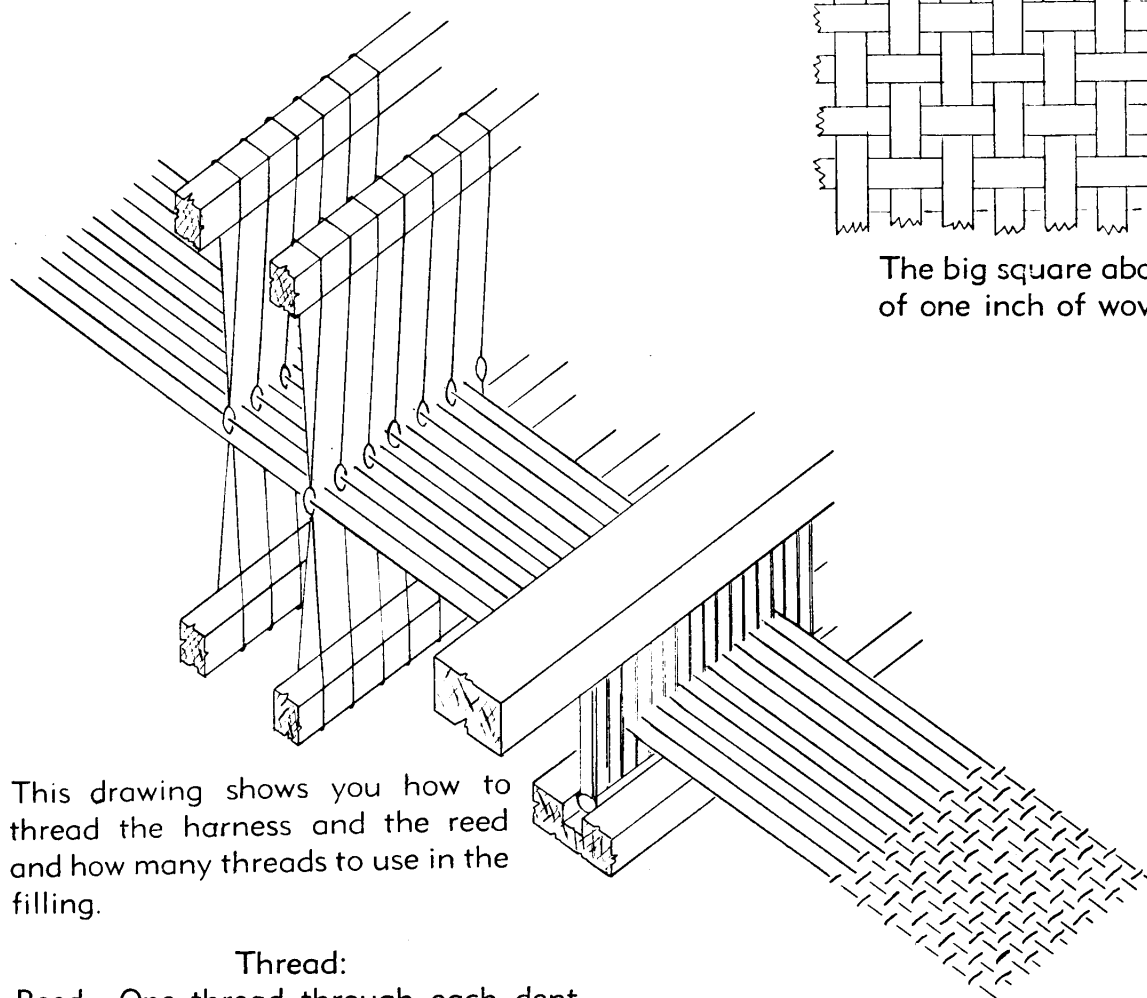

This drawing shows you how to thread the harness and the reed and how many threads to use in the filling.

Thread:

Reed—One thread through each dent

Harnesses—One thread through the front harness

One thread through the back harness

Repeat

Weave:

One filling thread in each shed.

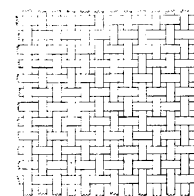

The little square is exactly the size of one inch of the woven material. You can use this as guide in planning the number of threads per inch in your weaving.

6T per inch—with warp and filling the same size

Pattern of one inch of woven material

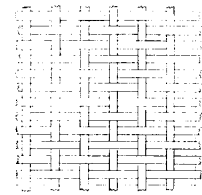
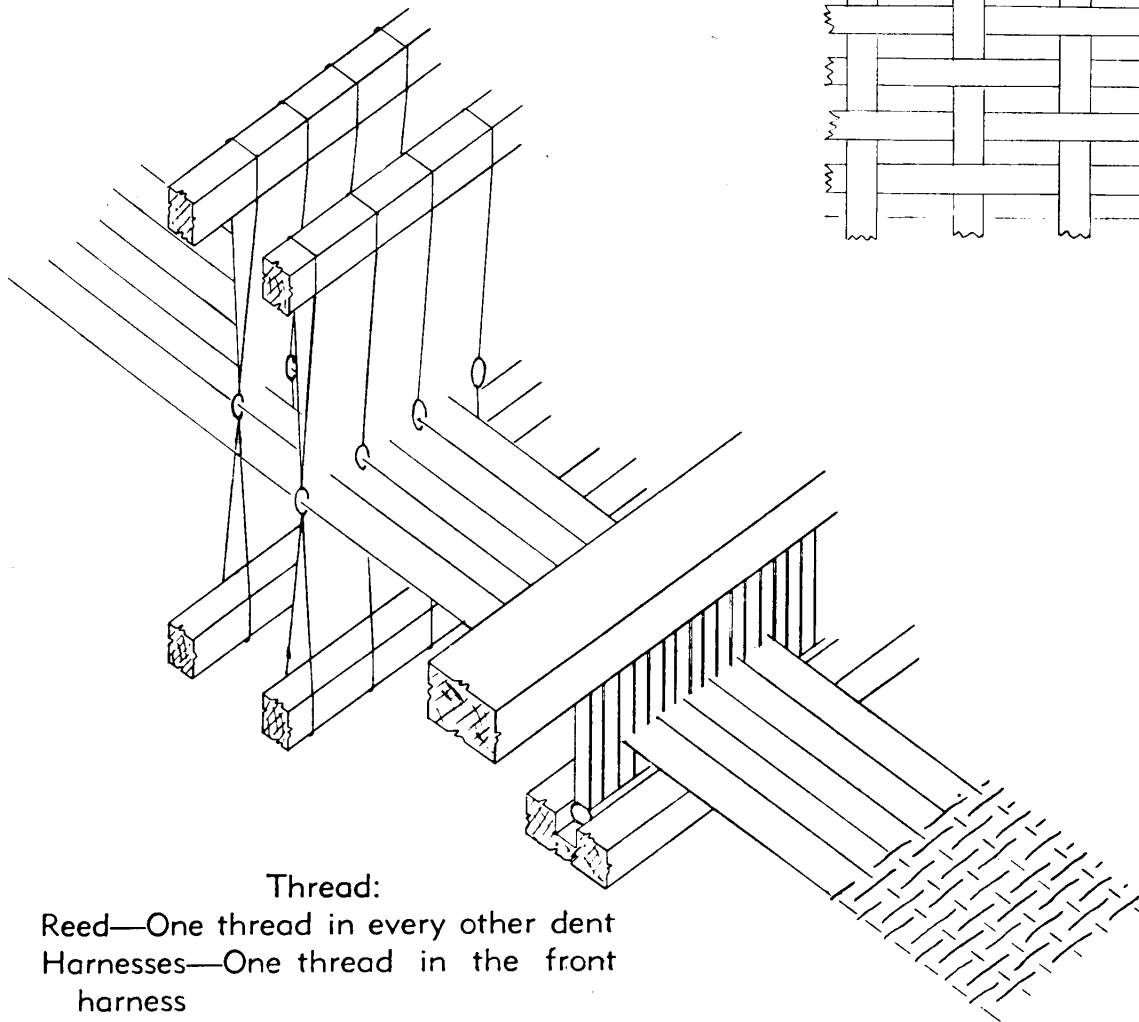
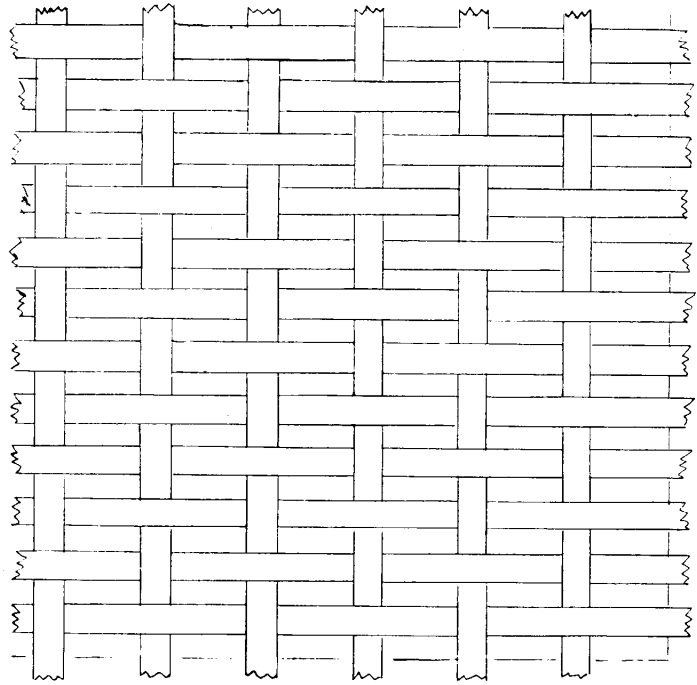

Actual size of one inch of the material

Thread:

Reed—One thread in every other dent

Harnesses—One thread in the front harness

One thread in the back harness

Repeat

Weave:

One filling thread in each shed.

6 T per inch—with filling thread much larger than the warp as in rag rugs

Pattern of one inch of woven material

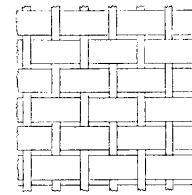
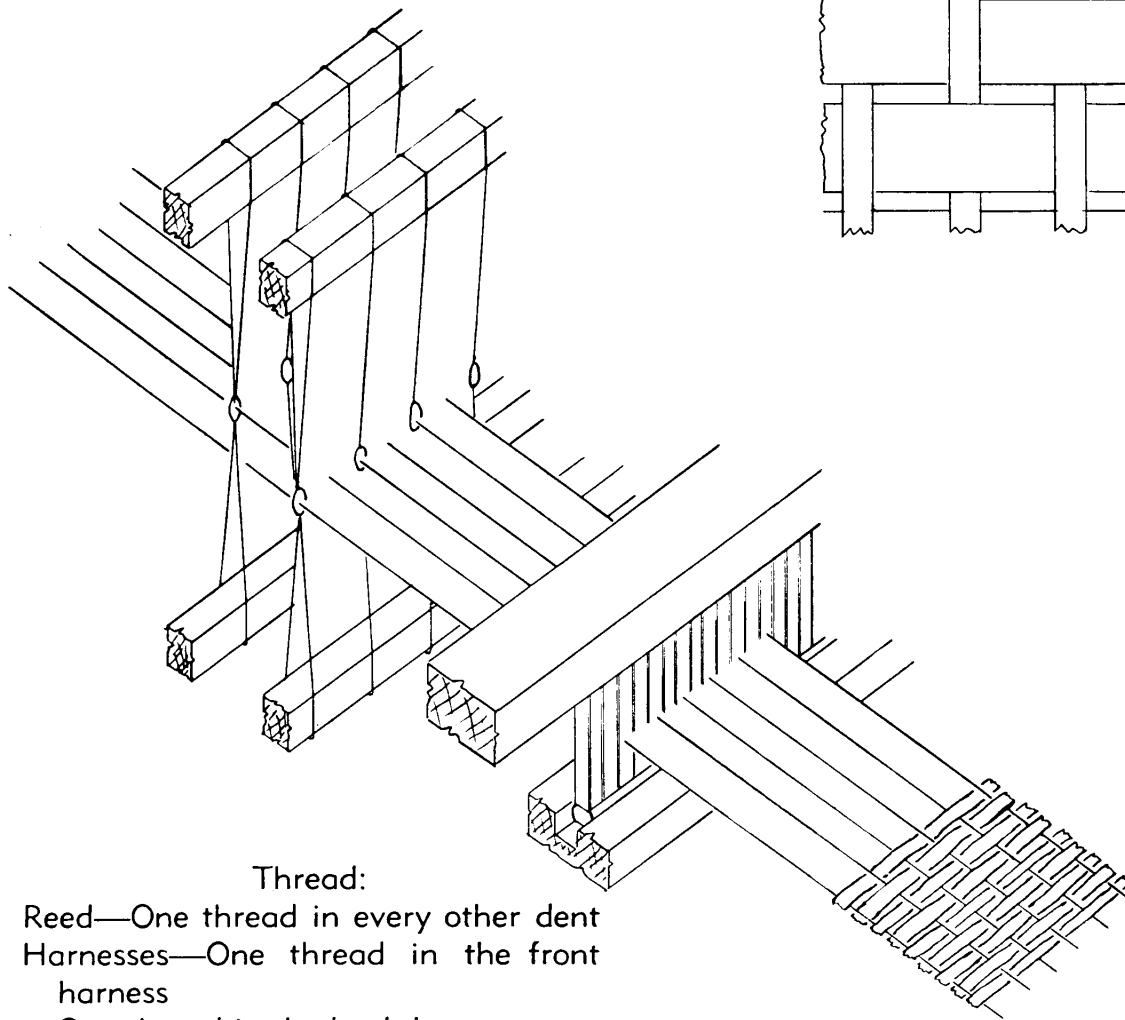
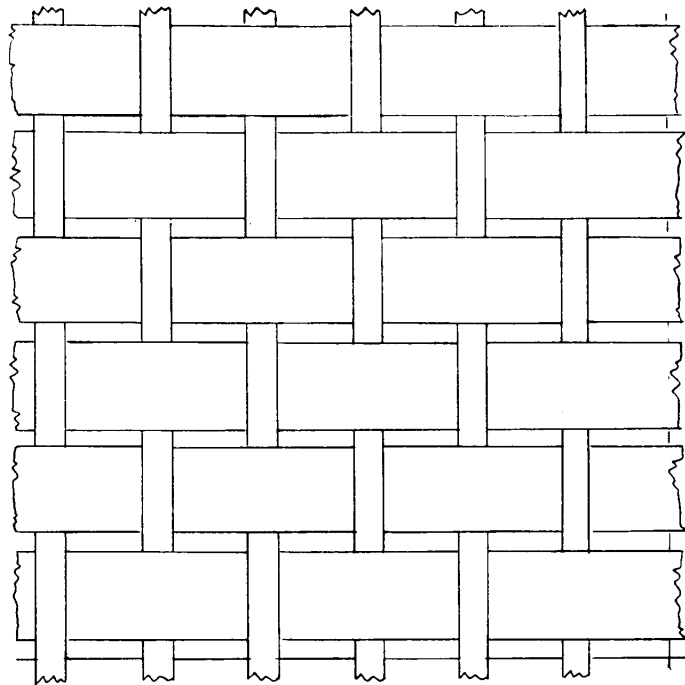

Actual size of one inch of the material

Thread:

Reed—One thread in every other dent
Harnesses—One thread in the front harness
One thread in the back harness
Repeat

Weave:

One filling thread or carpet strip in each shed

8T per inch

Pattern of one inch of woven material

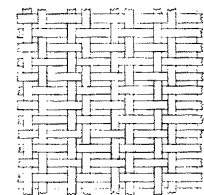
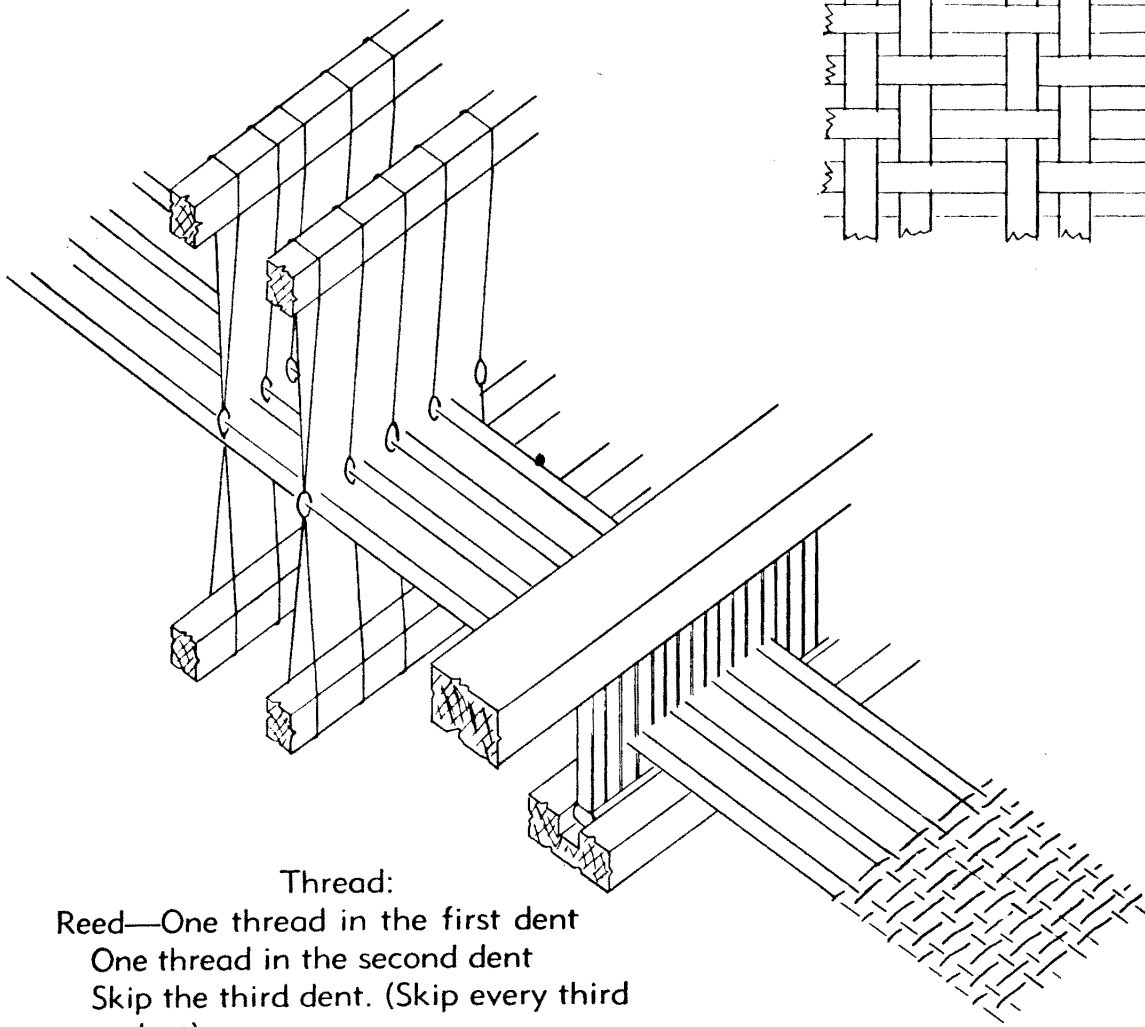
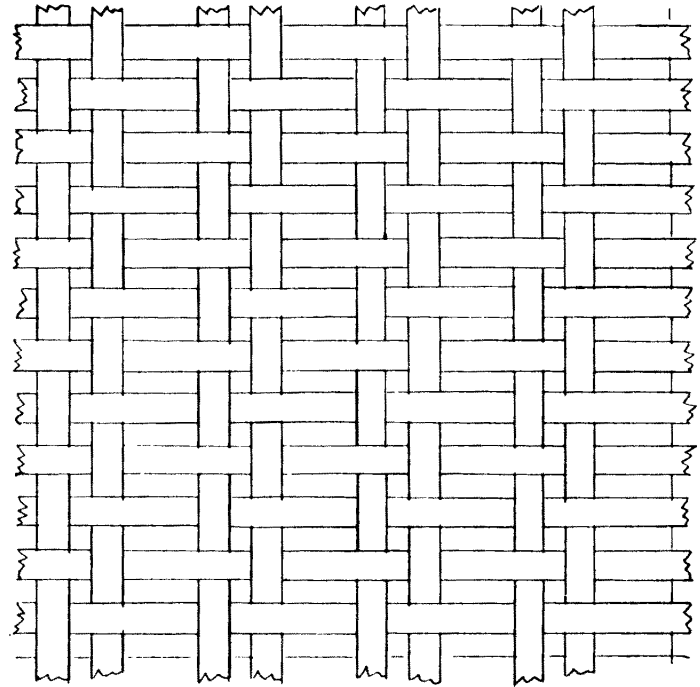

Actual size of one inch of the material

Thread:
Reed—One thread in the first dent
One thread in the second dent
Skip the third dent. (Skip every third dent)
Repeat
Harnesses—
One thread in the front harness
One thread in the back harness
Repeat
Weave:
One filling thread in each shed.

12T per inch with irregular threading

Pattern of one inch of woven material

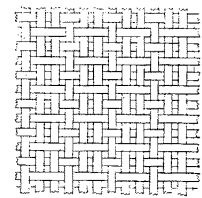
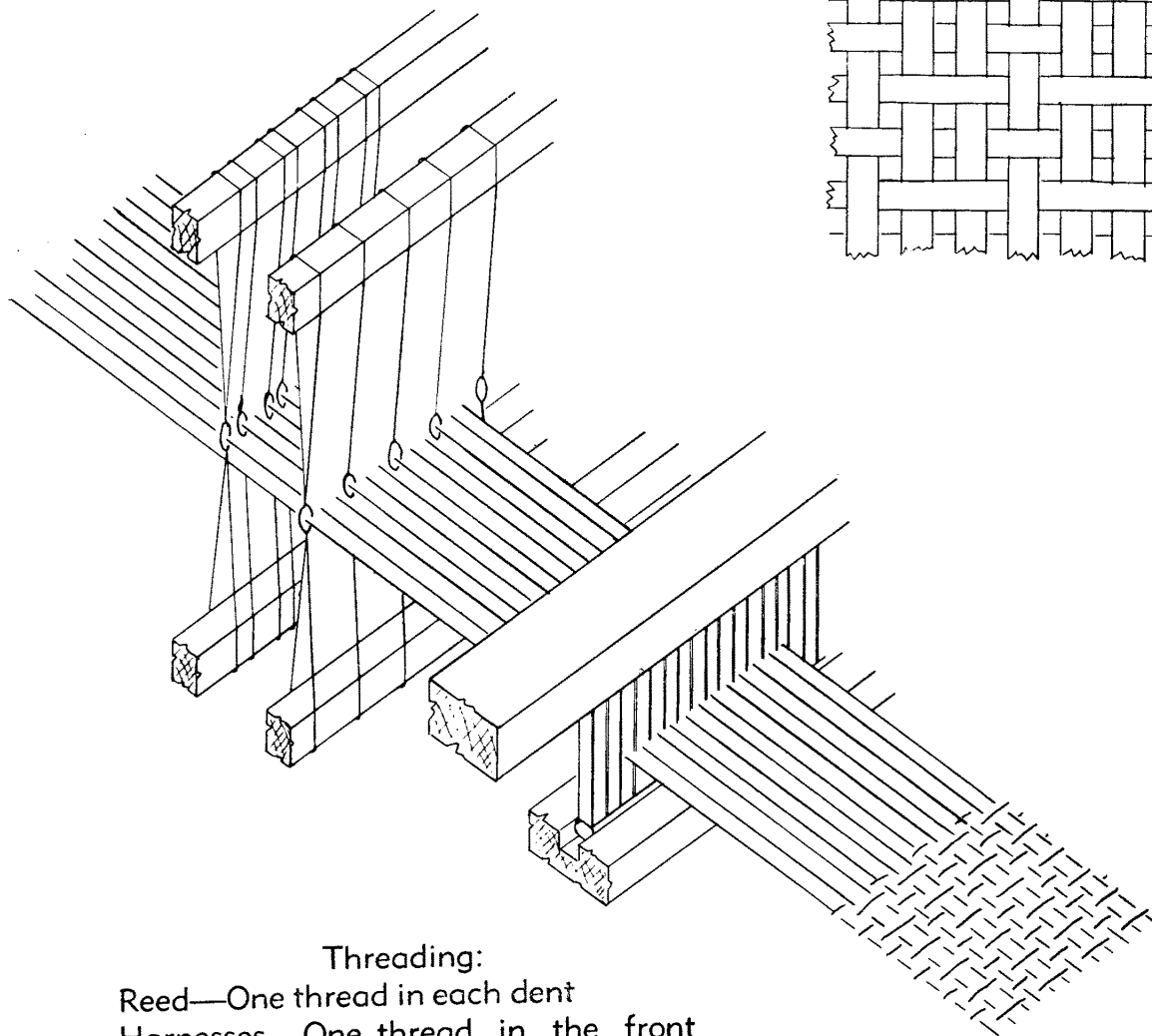
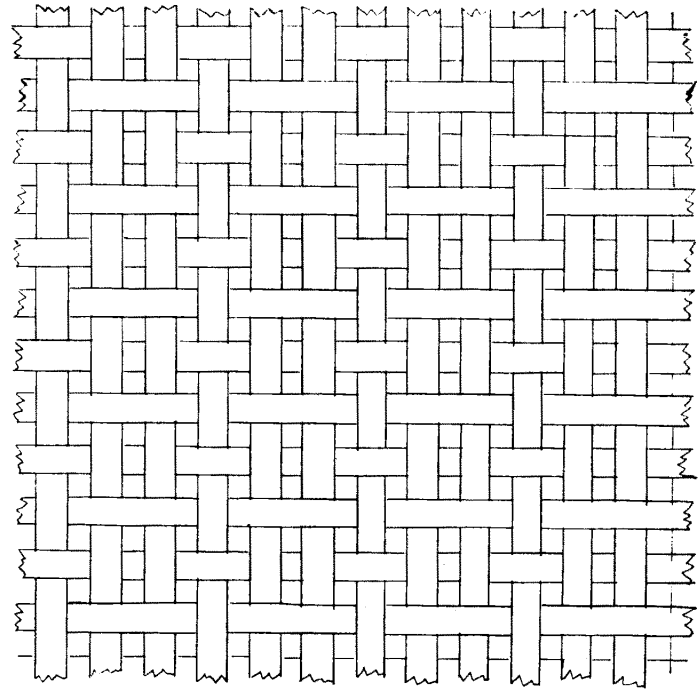

Actual size of one inch of the material

Threading:
Reed—One thread in each dent
Harnesses—One thread in the front
harness
Two threads in the back harness
Repeat

Weave:
One filling thread in each shed.

12 T per inch—double threads in the
warp and single in the filling.

Pattern of one inch of woven material

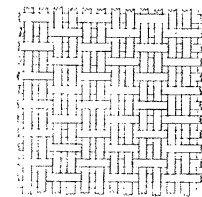
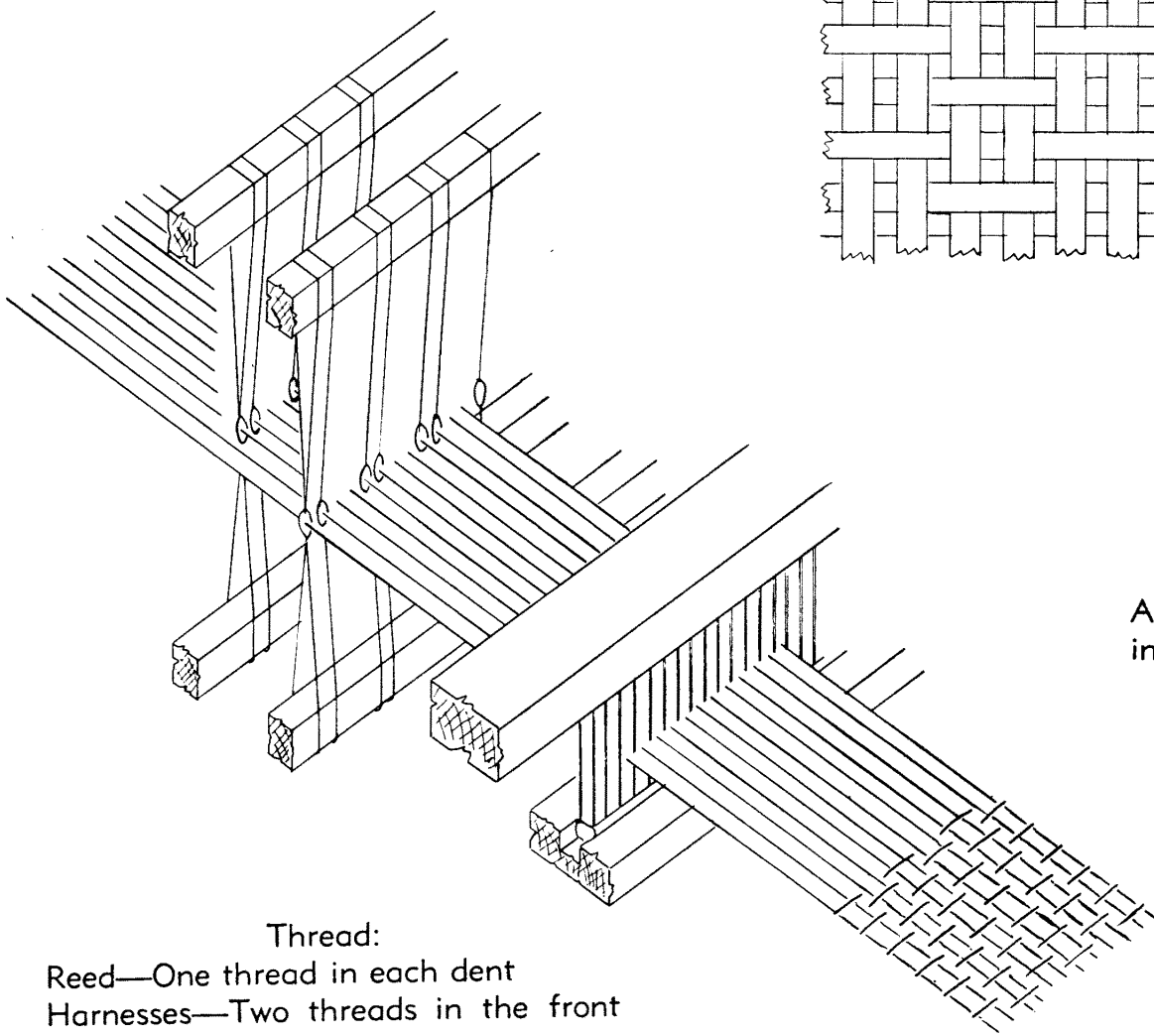
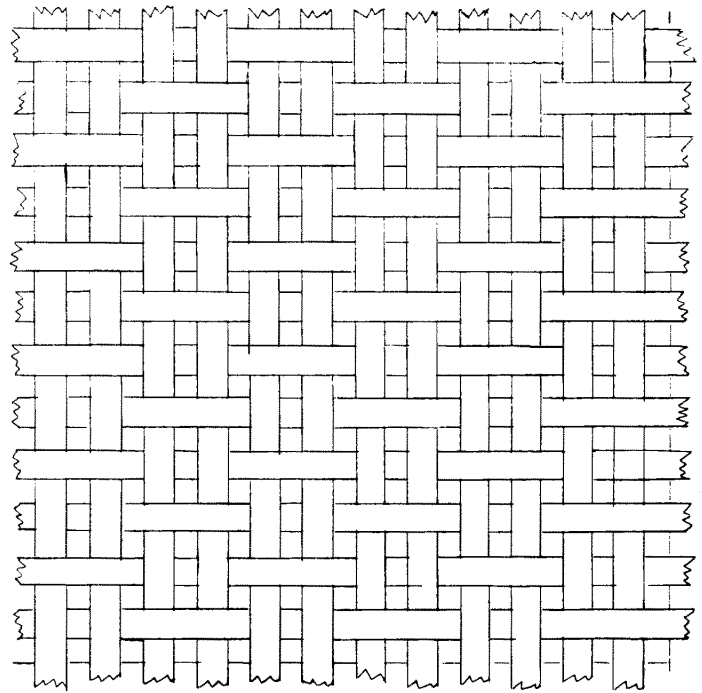

Actual size of one
inch of the material

Thread:
Reed—One thread in each dent
Harnesses—Two threads in the front
harness
Two threads in the back harness
Repeat

Weave:
One filling thread in each shed.

12 T per inch—Basket weave

Pattern of one inch of woven material

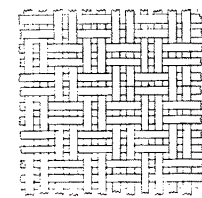
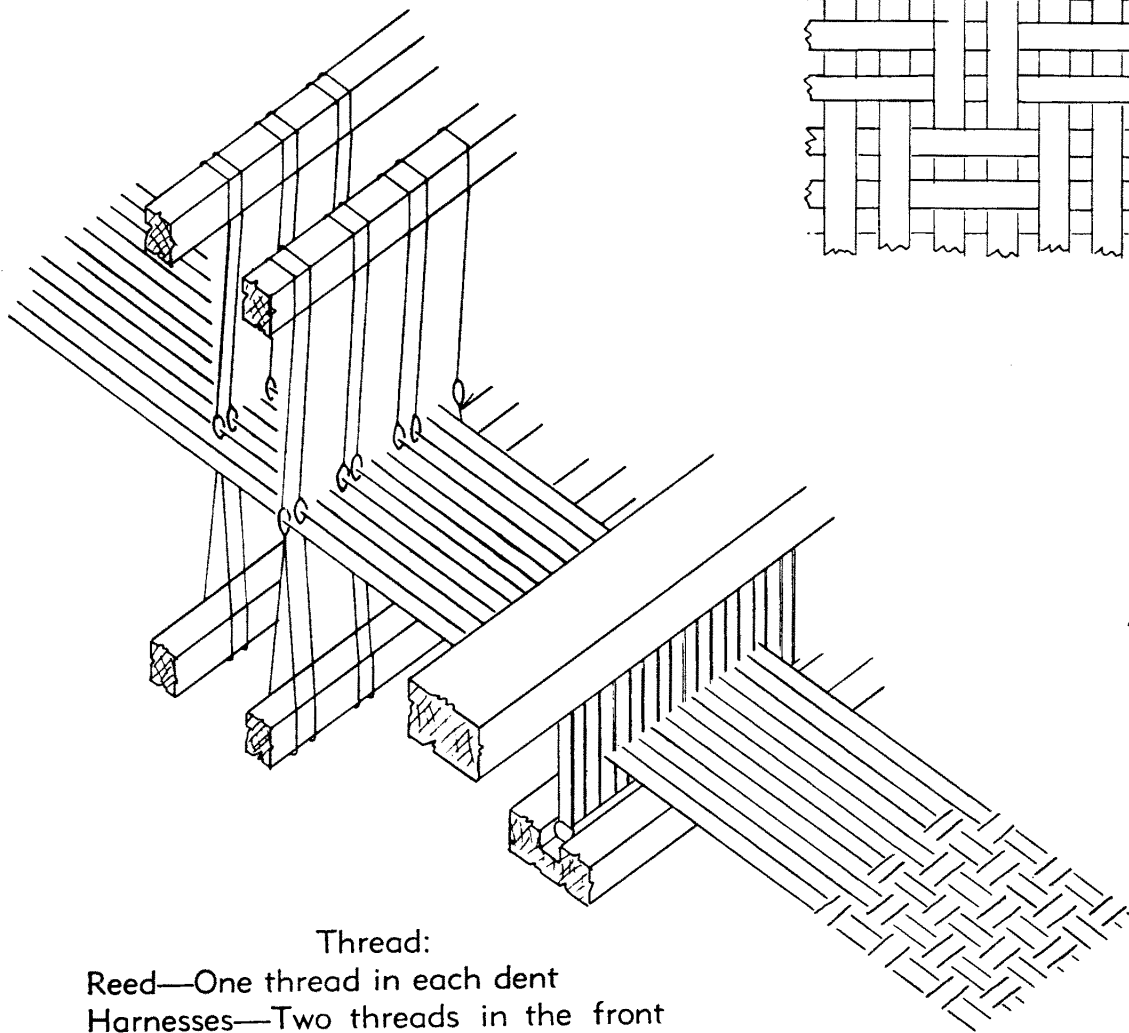
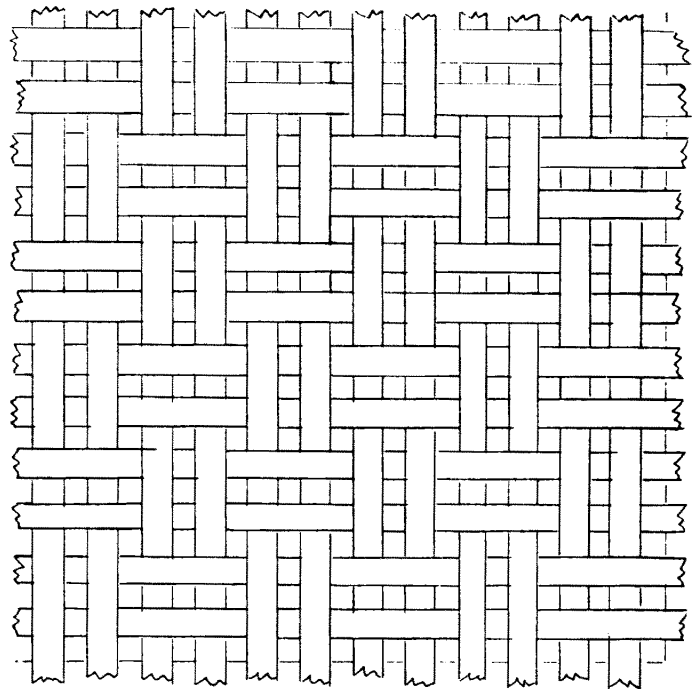

Actual size of one inch of the material

Thread:
Reed—One thread in each dent
Harnesses—Two threads in the front harness
Two threads in the back harness
Repeat

Weave:
Two filling threads in each shed.

24T per inch

Pattern of one inch of woven material

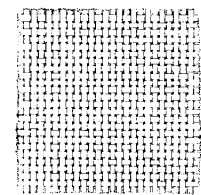
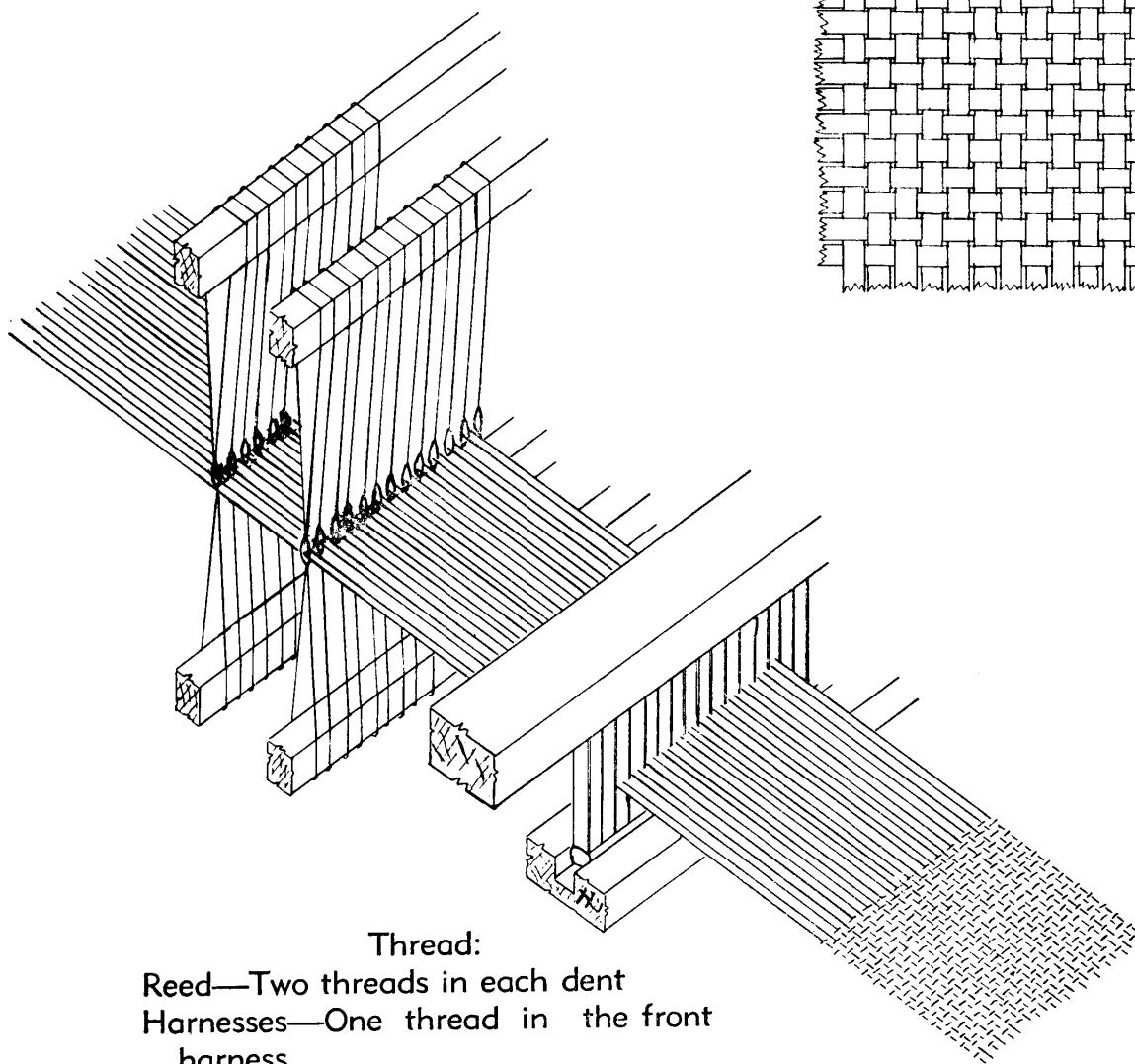
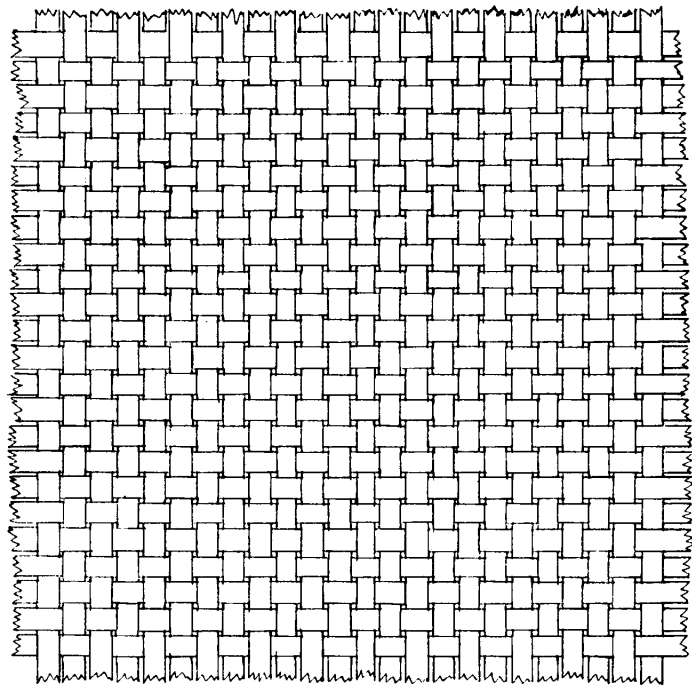

Actual size of one
inch of the material

Thread:
Reed—Two threads in each dent
Harnesses—One thread in the front
harness
One thread in the back harness.
Repeat

Weave:
One filling thread in each shed.

TERMS

1. DENT—the space between the metal strips of the reed.
2. FILLING OR FILLER—thread or strip of material used to fill or weave into a warp.
3. FRINGE—a border of hanging threads.
4. LINE OF WEAVING—end of the woven material nearest the reed.
5. PLY—the number of strands in a piece of yarn as 2-ply or two small strands twisted together. 2/40's means a 2-ply yarn of size 40.
6. SELVAGE—the outside edges of a piece of material.
7. SHED—the opening in the warp caused by raising or lowering the harnesses.
8. TENSION—the amount of stretch or pull on a thread or threads.
9. WARP—lengthwise threads in a piece of material. In the loom these are stretched from the front to the back of the loom.
10. YARN—any spun thread.
11. AIR-VU—the name of a system or type of three dimensional Engineering drawing that is scaleable. The drawn object appears as if it were being viewed from out in space. These drawings are made with an Air-Vu triangle which is $36^{\circ} 52' 11.63''$ and a pair of set proportional dividers. The opposite sides of a cube are drawn parrallel. All lines on the Air-Vu angle are drawn to a measured scale while all vertical lines are foreshortened with the proportional dividers to $\frac{3}{4}$ their measured length. These drawings can be dimensioned and measurements can be taken directly from them.