

SARGENT BURRING MACHINE

33. Opening Out of Wool.—The Sargent burring machine is an American type that has been introduced recently into British practice and that is doing good work on a fair range of medium wools. Its action is similar to that of the Sykes and Garnett machines, as may be seen from Fig. 10, which is a sectional view showing the principal working parts. The lattice *a* carries the wool to the feed-rollers *b*, which in turn bring it into the range of action of the picking cylinder *c*. This cylinder carries a number of rows of sharp teeth, and as the cylinder revolves in the direction of the arrow the teeth catch the wool emerging from the nip of the feed-rollers, open it out and carry it round over the grid *d*. Under the beating and opening action the wool is freed of a large part of its burrs, the latter falling through the grid into a chamber below, from which they are removed at intervals.

34. Action of Burr Rollers.—After the wool has been carried past the grid *d*, Fig. 10, it is caught by the teeth of the burr roller *e*, which revolves in the direction indicated by the arrow, and is carried round with the roller, the burrs projecting from its surface. The burrs are thus easily knocked off by the rapidly rotating beater *f*, whence they fall to the floor. The wool is stripped from the roller *e* by a similar roller *g* whose teeth point in the direction of rotation of the roller. This stripping is due to the fact that the surface speed of the roller *g* is greater than that of the roller *e*. The wool is carried round with the roller *g* until it comes beneath the beater *h*, which knocks off any remaining burrs, throwing them on to a tray placed above the burr roller. The wool is finally stripped from the roller *g* by the brush fan *i*, which sets up an air-current that blows the wool out of the machine. Only a portion of the wool constantly travelling round the picker cylinder *c* is removed by the roller *e*, and so, to increase the production of the machine, a duplicate set of burr rollers is placed above the first set, as shown. The action of the duplicate set is the same as that just described. A fan *j* draws air through the machine and carries away the dust and the lighter impurities.

35. Prevention of Waste.—At the points where the frame-work comes nearest to the under sides of the first burr rollers in both sets, small openings *k* and *l*, Fig. 10, are left, through which a current of air is continually passing, due to the action of the fan *j*. Consequently, any loose fibres not attached to the heavier burrs that are knocked from the burr rollers are drawn inwards

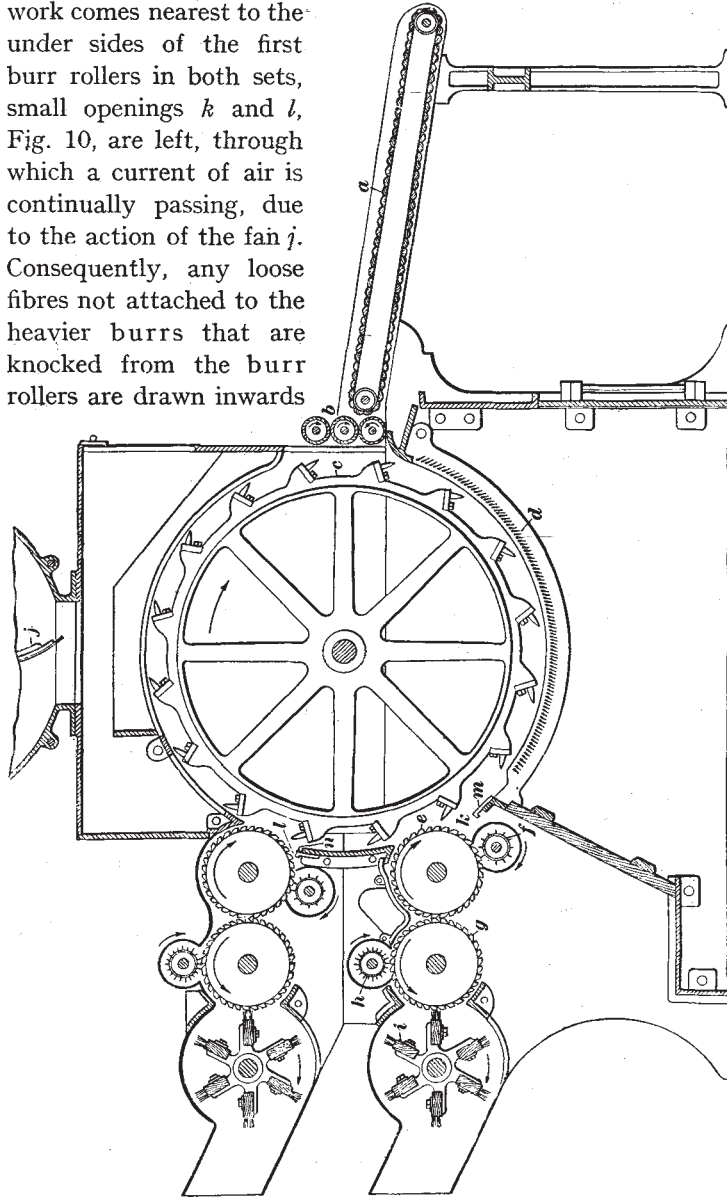

FIG. 10

and thrown back on the picking cylinder, thus saving wool that would otherwise pass away as waste. The sizes of the openings k and l may be altered by adjusting the plates m and n .

SINGLE BURR-ROLLER MACHINE

36. A burring machine with only one burr roller, instead of two, is often adopted in a mill using wools containing few burrs ; but in case a very burry wool is used, it is customary to run it

through a single burr-roller machine several times, so as to ensure the removal of all the burrs, since this machine is not nearly so effective as the double burr-roller machine previously described. A longitudinal section of a single burr-roller machine is shown in Fig. 11.

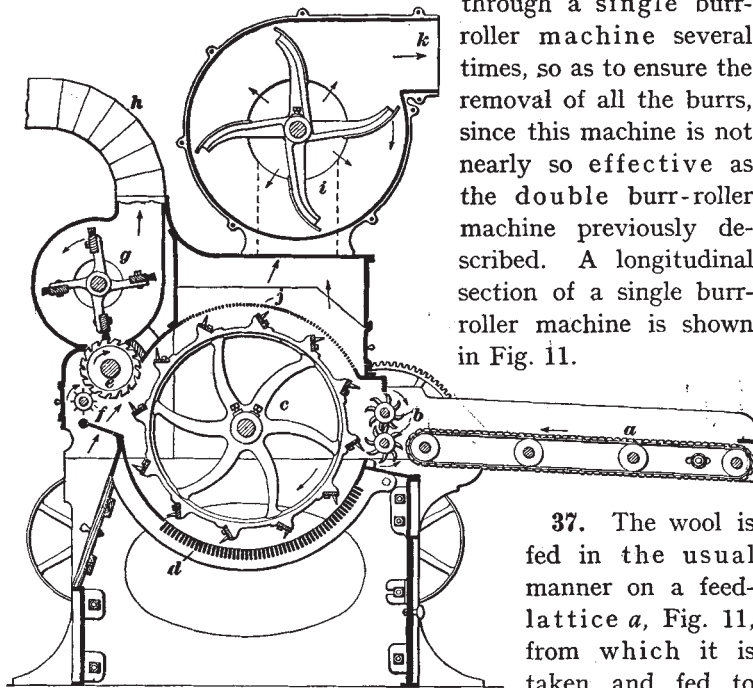

FIG. 11

37. The wool is fed in the usual manner on a feed-lattice a , Fig. 11, from which it is taken and fed to the machine by the toothed feed-rollers b . The picking cylinder c then takes the wool and carries it over the grid d , thus shaking out the loose dirt, which drops through into the lower part of the machine, from which it may be removed. The wool is deposited on the burr roller e , where the burrs are removed and cast on to the

floor at the rear of the machine by the burr beater *f*. The wool is removed from the burr roller by a rotating brush *g*, which also generates a current of air for delivering the wool through the pipe *h*. A constant current of air is maintained in the machine by a fan *i* that draws the dust through the screen *j*, which retains the wool. The dust is conveyed to the outside of the mill through the pipe *k*. The inlets for the air are under the feed-rollers and at the back of the machine under the burr beater.

BURR ROLLERS

38. Use of Suitable Burr Rollers.—In mills using a wide range of burry wools it is advisable to have two sets of burr rollers, a coarse set for coarse wools and a fine set for fine wools. If a burr roller with coarse teeth is used for fine wools, much of the wool will be pulled from the rollers along with the burrs and will be cast from the machine. Good burring means the removal of burrs with the loss of as little wool as possible. If a burr roller with finely set teeth is used for coarse wools, the wool will not penetrate into the spaces between the teeth and there will be danger of breaking the fibre and of losing a good deal of wool with the burrs.

39. Kinds of Wire for Burr Rollers.—The ordinary burr roller is made of iron, and after being trued has a continuous spiral groove cut round it. A specially prepared toothed wire is then wound round in this groove, after which the roller is ground so that the points of the teeth shall be true. The wire commonly used for covering burr rollers has teeth with flat tops, and in Fig. 12 are shown three types of wire. That in (*a*) has long tops, that in (*b*) has short tops, while those in (*c*) and (*d*) have both long and short tops. The short-top wire is suitable for fine, short wools, while long-top wire is especially adapted for use with longer and coarser wools. Either the long-top or the short-top form is usually adopted, but it is claimed that a combination of the two forms is better suited for

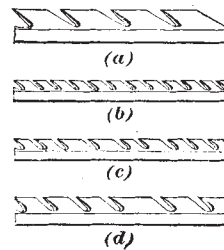

FIG. 12

burring certain medium wools, as it affords a compromise between the long-top and short-top forms.

40. Construction of Wire.—The wire used on burr rollers is drawn from fine steel and is made with a rib, or flange, at the base, so that, when wound on the roller, the base of the wire is held firmly. The teeth are all cut in the wire before it is wound on the cylinder. **Garnett wire**, as this wire is commonly called, takes its name from the inventor, who first used it on machines for tearing up rags in the preparation of shoddy and mungo. Old burr rollers and any other rollers that are covered with Garnett wire may be re-covered when damaged or worn out. Rollers covered with Garnett wire are sometimes termed *wire-wound rollers*, but in some of the American burring machines a special type known as the *steel-ring burr roller* is used. The teeth for this roller are cut on a solid steel ring with a hole of the exact diameter to be slipped on a smooth iron roller. The rings of teeth are kept apart by being alternated with packing rings of the proper thickness that have no teeth, the whole being firmly secured. The advantage of this roller is that it can be repaired without rewinding, as is necessary with the wire-wound rollers.

MANAGEMENT OF BURRING MACHINES

41. Cleaning of Burring Machines.—In regard to the management and proper care of burring machines, it may be said that one of the most important points is to clean the various parts of the machine periodically. All screens, grates, conducting pipes, etc., should be kept clean and clear of dirt and grease. If they are clogged up, they hinder the removal of the dirt from the wool and also reduce the efficiency of the fan, thus weakening the strength of the air-currents through the machine. Screens with small perforations will become completely coated with grease and gummy dirt, and when found in such condition should be taken from the machine immediately and washed with a strong solution of soda. When the gum is thick, a good deal of it can be scraped off before the screen is washed. The spaces under the picking cylinders or comb cylinders and under the beaters

of burring machines should be cleaned out frequently and regularly.

42. Clearing Fibre From Burrs.—After a batch of wool has been run through the machine, if much fibre is clinging to the burrs that have been cast out, the burrs are sometimes run through the machine again in order to obtain all the fibre possible. As a rule, however, this does not pay, not only because of the time required, but also because of the danger, where there are so many burrs, that some of them may pass forwards with the wool instead of being thrown out of the machine the second time.

43. Care of Shafts and Belts.—As burring machines run at high speeds, it is essential that all the bearings of rapidly rotating parts be oiled at least twice a day; otherwise, there is danger that the journals will heat and seize. All belts used in connection with burring machines should be laced, as there is danger of accidents if belt hooks are used, since the belts are in exposed places and it is necessary in many cases for the operator to work in close proximity to them. The brushes of burring machines wear out rapidly, and from time to time they should be set up closer to the burr rollers, or other rollers with which they may be in contact, and ultimately they should be replaced.

44. Setting of Burring Machines.—The setting of the working parts of a burring machine depends largely on the character of the wool to be burred, or cleaned. For a coarse, long-stapled wool, the burr rollers may be set farther from the picking cylinder than for finer and shorter wool. For the latter they may be set as close as possible without actually touching. The burr beaters should be set as close as possible to the burr rollers without knocking out the wool as well as the burrs, and in the case of the Sykes machine the ledger blade should be similarly set with respect to the comb cylinder. If the setting is too open, many burrs will escape the action of the beaters, while, if the setting is too close, they will pull the wool from the burr roller or comb cylinder.

45. Great care should be taken not to allow either the picking cylinder or the burr beaters to touch the burr rollers, since, if

this is the case, the burr rollers will be damaged and very soon ruined. The picking cylinder does not require to run very close to the burr rollers, since the centrifugal force, due to its rapid rotation, will throw the wool from the picking cylinder into the burr rollers. The brush fan should be set to strike into the burr rollers slightly, so as to clear them thoroughly of wool, and in the case of the Sykes machine the brush fan should be set sufficiently deep to clear the comb cylinder. Care should be taken, however, that the brushes do not strike the burr rollers with any great force, as this will quickly wear them out and necessitate their being replaced. Again, if the brushes are set too close, the wool is liable to be carried round by them. The setting of the parts of a burring machine must be done very carefully if undue breakage of fibre is to be prevented; however, there will be a certain amount of breakage during the burring process, just as in all the operations of opening prior to carding.

46. Special Receiving Chamber.—The wool from a burring machine is sometimes delivered by the current of air generated by the brush fan to a special room or receiving chamber. This is usually a wooden compartment provided with openings covered with wire screens, or perforated metal. The wool is blown from the burring machine to this room, the object of the screened openings being to let out the surplus air, but to retain the wool. Such machines as burring machines, which deliver the wool by means of a strong current of air, require some such room in which to deposit the wool in order to collect it within a small space.

47. The receiving chamber should be made large enough to accommodate a batch of wool easily, and should have a door of sufficient size to permit the easy removal of the cleaned wool. The door should have strong and suitable fastenings, and the openings in the room, which are covered with perforated metal to allow of the egress of air, should be of sufficient area so that the efficiency of the current of air from the burring machine will not be impaired. If the room is to be used for wool that is oiled in passing through the burring machine, the floor of the room should be covered with tin, or preferably zinc, to prevent the oil from soaking into the floor.

CARBONIZING

CARBONIZING PROCESSES

INTRODUCTION

48. Utility of Carbonizing Process.—Extracting, or, as it is commonly called, the carbonizing process, removes the vegetable matter by means of chemical action whereby the structure of the vegetable matter is destroyed so that it may easily be shaken or dusted from the wool. Wools filled with small burrs, shives, etc., are cleaned much more easily and cheaply by extraction than by a burring machine. Wools that contain only comparatively few burrs are usually run through a burring machine only, while wools that are quite burry are sometimes run through a burring machine to remove the larger burrs and are afterwards carbonized to destroy all the minute burrs and other vegetable matter, such as shives, dust, chaff, etc., that may have escaped the burring machine.

49. The carbonizing process is now becoming very common, especially on the Continent, where it has been brought to a high degree of perfection. When wools contain a large amount of fine chaff and straw, carbonizing, or extracting, is indispensable for their complete removal. In some mills it is the custom to throw aside the most burry portions of the fleece during sorting and carbonize these portions alone, the rest of the fleece simply being run through a burring machine.

50. Principle of Carbonization.—The principle of carbonization depends on the action of certain chemicals that will destroy the vegetable matter, but will not injure the wool if the process is properly performed. It is evident that alkaline chemicals are not suitable for carbonizing purposes, since they readily destroy

the wool fibre without injuring the vegetable matter. A 2° Beaumé solution of caustic soda will dissolve wool completely, if boiled, but it will not affect burrs, cotton fibres, or any vegetable matter. Acids are, however, particularly adapted for carbonizing, since, if not too strong, there is no injurious effect on the wool, while even a dilute solution will effectually destroy burrs, chaff, cotton, or any other vegetable matter.

51. Vegetable matter consists principally of a substance known as **cellulose**, the constituents of which are carbon, hydrogen, and oxygen, proportions indicated by the chemical formula $C_6H_{10}O_5$; from an examination of this formula, it will be seen that the hydrogen and the oxygen are present in the same proportions as that in which they occur in water, the constituents of water being hydrogen and oxygen in the proportions represented by the chemical formula H_2O . Therefore, in considering the underlying principle of carbonization, it may be assumed that all the vegetable matter, composed mainly of cellulose, consists of carbon and water in certain proportions. If these two substances can be separated by chemical means, or split up into carbon and water, the latter can be evaporated away, thus leaving the carbon in a brittle form, so that it may easily be broken into powder which can be removed by any one of the mechanical means adopted in carbonizing establishments. The principal agents used for carbonization are sulphuric acid (oil of vitriol), hydrochloric acid (muriatic acid), aluminium chloride, magnesium chloride, and bisulphate of soda.

SULPHURIC-ACID PROCESS

52. **Commercial Sulphuric Acid.**—Commercial sulphuric acid, or oil of vitriol, contains varying amounts of water and also other impurities, as iron, lead, arsenic, etc. In addition, the acid is often discoloured by organic dust that has been charred by the action of the liquid. The commercial product, however, is usually pure enough to meet the requirements of carbonizing. In using acid on wool, care should be taken to have the solution weak, so that the fibre of the wool will not be injured in any way ;

for, though acids have no appreciable effect on the fibre when dilute, yet, if they are strong and any heat is applied, a weakening of the fibre will result, and the material will have a harsh feel and a yellow colour.

53. Strength of Solution.—A 1° Beaumé solution of sulphuric acid would be sufficient to destroy the smaller particles of vegetable matter in wool, but for effectually carbonizing large burrs, etc., a stronger solution is found to be necessary in actual practice. The strength of the solution should vary from 2° to 6°, according to the material that is being treated and the number and kind of burrs that it contains, as the harder the burrs, the stronger should be the solution. Wool that is naturally tender should be carbonized with as weak a solution as possible, while stronger material may be treated with a stronger solution. In actual practice it is found that a strength of 4° or 4½° Beaumé is about right for wool-carbonizing solutions in the majority of cases.

54. Making Acid Solution.—In diluting sulphuric acid with water, the acid should always be poured into the water in a thin stream; water should never be poured into strong acid, since a large amount of heat is generated when the acid and water unite, and if a large quantity of acid is present the solution is liable to explode and cause terrible burns if it comes in contact with the workman. Care should be taken also to stir the liquor thoroughly with a pole, as otherwise the acid, being heavier than the water, will settle to the bottom of the tank and the hydrometer will indicate a weaker solution than is actually present. Again, if the liquor is not well mixed, some of the wool is liable to be injured by the action of that part of the liquor in which the acid is too strong, while other portions of the material will not have the burrs effectually carbonized because of their being in contact with only a very weak solution.

55. Steeping Wool.—The operation of carbonizing with sulphuric acid consists of steeping the wool in a solution of sulphuric acid in large wooden tanks. This wool has been washed, since if wool is submitted to the action of the acid in its greasy state

there will be a tendency for the grease to become fixed to the fibres, thus making subsequent washing very difficult. On the Continent the theory is held that wool should be carbonized prior to washing, in order that the grease may coat the fibres and protect them from injury. The length of time that the wool is immersed in the acid solution depends on the strength of the acid, which in turn should be governed by the character of the fibre. The strength of the acid solution most commonly used is about 4° or $4\frac{1}{2}^{\circ}$ Beaumé, and an immersion of 40 minutes in a solution of this strength is generally sufficient for the most burry materials. The wool should be kept under the solution while it is in the acid tank. It does not harm the wool to any appreciable degree to stay in the acid solution for some time, provided that the acid is not too strong and the material is completely submerged. Although it is desirable to have the material thoroughly saturated with the acid solution, it is not advisable to pole the material round in the soaking tank, as the benefit derived is not great enough to compensate for the danger of felting the material.

56. Removing Excess of Solution.—When the wool is thoroughly saturated with the acid solution it is taken out and the moisture is partly removed by a hydro-extractor, the process being termed *whizzing*. The basket of the hydro-extractor should be made acid-proof in some manner, if it is intended to be used for carbonizing work; otherwise, the acid will attack and destroy it. The liquor driven out of the wool in the hydro-extractor should be allowed to run into a tank, from which it can be passed back into the soaking tanks and used again. The excess of acid may be removed before drying by means of a pair of squeeze rollers instead of a hydro-extractor, if so desired.

57. Drying Material.—The wool is next dried at a temperature of from 160° to 165° F. in an ordinary hot-air dryer, after which it is run through a second dryer and subjected to a temperature of from 200° to 230° F. A temperature of 210° F. in the second dryer is usually about right for wool that has been properly treated with acid. When wool is dried in this manner, it usually occupies about 20 minutes in running through each dryer. A two-compartment dryer is more convenient than two single

dryers for drying wool after acid treatment, the temperature in the first compartment being kept at about 165° F. and in the second at about 210° F. With some of the modern dryers it is usually found that one machine will do the work, if it is arranged so that the wool is not subjected to a too hot current of air until it is fairly well dried ; that is, it must first be dried at a fairly low temperature and then be brought into contact with more highly heated air.

58. Alternative Method of Drying.—The temperature for drying is sometimes made as high as 250° F., but this does not act so mildly on the wool, and is liable to make the fibre of fine wool tender and of a yellow colour. Instead of using two single dryers as explained above, some mills have rooms in which the material can be subjected to the high temperature after being dried in an ordinary dryer. This method is inconvenient, however, as the material has to be spread on racks by hand and removed in the same way, which is a laborious operation as compared with the continuous progress of the material in a machine dryer.

59. Suitable Temperatures for Drying.—The temperature in drying must be raised to at least 180° F. or carbonization will not take place with sufficient rapidity, although a lower temperature will do the work provided that a long enough time is allowed ; but 180° may be taken as the general commercial minimum. It is, however, considered good practice in carbonizing to use weaker solutions and dry at higher temperatures rather than the reverse. It is always best first to dry the wool at a somewhat lower temperature and then to increase the heat for a short period in order to complete the carbonization. The wool is sometimes dried in an apron dryer with an attachment of crushing rollers for pulverizing the charred vegetable matter, in order that it may be more easily removed by the *carbonizing duster* through which the material is passed after being dried.

60. Effect of Acid on Metal Work.—The carbonizing duster, which will be described later, is generally equipped with a series of crushing rollers for crushing the carbonized vegetable matter,

as well as means for dusting the crushed matter from the material. For drying acid-treated material, it is necessary that the aprons and other metal work of the dryer that are in contact with the material shall be well protected, in order to prevent the acid from attacking and destroying them. In order to obtain the best results, the material should not be exposed to the air for any length of time between acid treatment and drying.

61. Action of Acid During Drying.—The action of the acid in the drying process, during which carbonizing really takes place, is as follows: As the moisture is evaporated, the acid, which has a great avidity for water, attacks the burrs and other vegetable matter, which naturally hold the moisture longer, and extracts it from them, in so doing changing the nature of their structure and converting them into carbon compounds that crumble readily; in other words, the acid dries out the superfluous water from the moist cellulose, until the vegetable matter is reduced to hydro-cellulose. If the wool is examined carefully, it will be seen that the burrs and other vegetable matter, although they have not lost their form, are in a very brittle state, and on being squeezed, or crushed, crumble to a fine dust or powder.

62. Removing Burrs and Acid.—When the wool has been dried, it is passed between a series of heavy crushing rollers and the carbonized vegetable matter is pulverized and easily shaken or beaten out. The wool is then soaked or washed in clean water, to take out as much of the acid as possible, and is subsequently treated with an alkaline solution, the alkali usually employed being either soda ash, which is the commercial name of anhydrous sodium carbonate, or pearl ash, which is the commercial name of anhydrous potassium carbonate. This process is called **neutralizing**. The alkaline solution and the acid neutralize each other, or combine to form a salt that is neutral; that is, the resulting solution has neither acid nor alkaline properties. The strength of the alkaline solution should not exceed 4° Beaumé and the wool should remain in the solution long enough to become thoroughly saturated, after which it should be rinsed in water. No appreciable deterioration of the wool takes place if the carbonization is properly performed.

ALUMINIUM-CHLORIDE PROCESS

63. Aluminium Chloride.—In the aluminium-chloride process, also termed Joly's process, aluminium chloride is the carbonizing agent. Aluminium chloride is a milder agent than acid and acts less harmfully on the wool fibre ; therefore, there is less danger of injury to the wool. Another advantage of aluminium chloride is that it does not attack the iron that is used more or less in the construction of dryers, hydro-extractors, etc. If wool that has been saturated with sulphuric acid comes in contact with iron before it is dry, the acid attacks the iron and a rust spot is made on the wool. Aluminium chloride also possesses antiseptic properties to some extent. The aluminium-chloride process is being introduced to some extent in the best mills to supersede the sulphuric-acid process.

64. Carbonizing Operation.—The wool to be carbonized is saturated, in a box or tank, with a 6° to 8° Beaumé solution of the chloride from 40 minutes to 1 hour, and is afterwards partly dried in a hydro-extractor and then completely dried as in the sulphuric-acid process, with the exception that the temperature must be about 240° F. to ensure complete carbonization. The wool is then passed through a carbonizing duster and the carbonized vegetable matter is crushed and removed. After the wool has been dusted, it is washed with clear water or water with a small quantity of fuller's earth added, as the residue from the chloride is easily removed. *Fuller's earth* is a clay-like substance that is used in the scouring and fulling of woollen cloth.

The action of the aluminium chloride depends on the fact that, when a solution of this substance and water is evaporated at a considerable temperature, the chloride is decomposed and hydrochloric-acid vapour is liberated. The acid vapour attacks the vegetable matter and is the real carbonizing agent.

65. Advantages of Aluminium-Chloride Process.—The advantages claimed for the aluminium-chloride process, summed up in a few words, are as follows : (a) It is the simplest method and one attended with the least inconvenience to the workmen, there being no disagreeable acid fumes for them to breathe.

(*b*) Wool carbonized with aluminium chloride retains its elasticity, softness, and natural feel to a greater extent than wool extracted with acid; nor is there the danger of weakening the fibre by overheating that attends the acid treatment. (*c*) The danger of staining the wool with iron rust is eliminated, as the chloride does not attack iron as does acid. The wool may thus be dried by steam pipes without danger of injury.

66. Disadvantages of Aluminium-Chloride Process.—Among the disadvantages of the use of aluminium chloride as a carbonizing agent may be mentioned the following: (*a*) The process is apt to be somewhat uncertain, owing to the tendency of the aluminium-chloride solution suddenly to lose carbonizing strength, whereas the sulphuric-acid process is unailing. (*b*) Material carbonized with aluminium chloride will not take certain colours so well as material carbonized with sulphuric acid. (*c*) Aluminium chloride has a tendency to decompose into a sticky, greasy compound that coats the inside of the dryers and dusters, and can only be removed by the use of sharp scrapers. This is a disadvantage in dusting, as the duster should at all times be clean, in order to obtain the best results. No compound of this nature results from the use of sulphuric acid as a carbonizing agent.

67. Compressed-Air Apparatus for Carbonizing.—The aluminium-chloride process of carbonizing is occasionally performed with apparatus designed to be operated by compressed air. With this apparatus, as usually arranged, the carbonizing liquor is not only forced through the wool by compressed air, but the latter also furnishes power for removing the wool from the soaking tanks. The usual arrangement is to have two wrought-iron soaking tanks about 6 feet in depth and 5 feet in diameter. These are connected at the bottom by a suitable pipe provided with a valve and the tanks are equipped with perforated false bottoms. The material to be carbonized is contained in wrought-iron cages perforated on the bottom and sides and so arranged as to be lowered into the soaking tanks to rest on the false bottom. The carbonizing liquor is stored in a supply tank, so placed that the liquor may be run into the soaking tanks by gravity. The compressed air is obtained by means of an air compressor and is

stored in a wrought-iron storage tank connected with the soaking tanks by suitable pipes. The compressor automatically maintains a pressure of 60 pounds per square inch in the storage tank.

68. Operation of Soaking.—In operation, the material to be carbonized is placed in the cage in the first soaking tank and the carbonizing liquor is run in from the supply tank until the material is completely submerged, the connection with the second soaking tank being closed during this operation. The cover is now securely fastened on to the first soaking tank. The second tank is then filled with wool and the connection between the two tanks is opened; at the same time the compressed air is admitted to the first soaking tank from the storage reservoir. The pressure thus obtained in the first tank drives the liquor down through the wool in the first tank and up through the wool in the second tank. To resist the tendency of the wool in the second tank to be forced up by the air a wooden frame is placed across the top.

69. When the liquor is all out of the first soaking tank, which is indicated by its rising to the same height in the second tank, the connection between the two tanks is shut off, as is also the connection between the first soaking tank and the compressed-air reservoir. Then, by means of an exhaust valve, the compressed air remaining in the first tank is let out and the cover is removed. The first tank may now be emptied and refilled, the hoisting and lowering of the cage being accomplished by means of compressed air. The cover is then securely fastened down on the second tank, the connection between the two tanks is opened, and compressed air from the reservoir is admitted to the top of the tank, which forces the liquor down through the wool in the second tank and up through the wool in the first, which is the reverse of the initial operation.

70. Completing Carbonizing.—The soaking operations just described are repeated until the entire batch to be carbonized has been treated with the chloride solution, after which the liquor is removed from the soaking tanks and stored in the supply tank. This may be accomplished by closing all the outlet valves except

the one to the supply tank and admitting compressed air to the soaking tank, whereupon the liquor will be rapidly driven back to the storage tank. The wool is afterwards submitted to the action of the hydro-extractor, and to the operations of drying, dusting, and washing.

MAGNESIUM-CHLORIDE PROCESS

71. The process of carbonization with magnesium chloride is similar to that employed with aluminium chloride, the effects also being of a similar nature. The wool to be carbonized is saturated in a solution of magnesium chloride having a strength of from 5° to 6° Beaumé for one-half or three-quarters of an hour; it is then taken out, and the excess of moisture is removed by a hydro-extractor. The material should next be dried as in the sulphuric-acid process, and, after being allowed to cool, dusted and washed as in the aluminium-chloride process. Before carbonization by either the aluminium-chloride or the magnesium-chloride process, it is essential that the wool should be absolutely free of all soap used in the process of washing, since, if any remains on the wool, it will immediately be decomposed and form insoluble soap compounds of aluminium or magnesium, according to the agent used. Carbonization, when using solutions of either aluminium chloride or magnesium chloride, depends entirely on the temperature in the drying. This should be such as to cause the solution to give off hydrochloric-acid vapour, which acts on the cellulose. Theoretically, carbonizing with aluminium chloride or magnesium chloride is a dry process, as these substances have no effect on vegetable matter when in solution. The principal advantage of aluminium chloride over magnesium chloride is that the former gives off hydrochloric-acid vapour at a temperature of from 5° to 10° F. less than the latter. The principal advantage of magnesium chloride is its cheapness.

HYDROCHLORIC-ACID PROCESS

72. In the hydrochloric-acid process, or, as it is often termed, the dry-carbonizing process, the carbonizing is accomplished by an agent in the form of a vapour. This process is, however,

confined mainly to carbonizing rags, as it is a failure on new wool, owing to the tendency it has of turning the fibre yellow. Carbonization by this method is sometimes performed by spreading the rags on racks in a chamber heated to from 200° to 230° F., where they are treated with the fumes of the hydrochloric acid. The chemical action is exactly the same as that of the sulphuric-acid process and a 2-hour or 3-hour treatment is sufficient, after which the material should be dusted and neutralized. Carbonization by the dry method is more usually accomplished in a large rotating iron cylinder, or box, which is heated by hot air, the fumes of acid being passed into the cylinder from a retort. The rotation of the cylinder turns the material over and exposes all parts of it to the action of the gas.

BISULPHATE-OF-SODA PROCESS

73. A carbonizing agent that has recently come into use is bisulphate of soda, or sodium hydrogen sulphate, the process in which it is used being known as **Spennarth's process**. The agent used is about 40 per cent. cheaper than commercial sulphuric acid and it has a less injurious effect on the colour of the wool, since, instead of forming a dark-brown compound, as is the case with sulphuric acid, a white compound is formed during carbonizing. It is also claimed that this agent has a strengthening effect on the wool, rather than a deleterious effect. A point, however, which must be noted is that the wool should be taken immediately to the crushing and dusting machine from the dryer; for, if a considerable time elapses from the time the material leaves the dryer until it is submitted to the action of the crushing and dusting machine, the burrs are not so easily broken up and shaken from the material.

CARBONIZATION OF CLOTH

74. Extracting, or carbonizing, is not confined to raw material, as very often the cloth is carbonized after it is woven. Woven cloth is carbonized either by sulphuric acid or by aluminium chloride, the object being to remove moths or minute particles

of vegetable matter that have not been removed in the process of manufacture and that otherwise would have to be picked out by hand. The action of the carbonizing agents is not confined to motes and such vegetable impurities, but extends to cotton and other vegetable fibres. This fact is made use of in recovering the wool fibres from manufactured goods that contain both cotton and wool. The wool thus recovered is known as **extract**. Both the sulphuric- and hydrochloric-acid processes are used, but more often the latter. The cotton is removed from the fabric, and the wool that remains is worked over again, that is, remanufactured. An interesting method of forming fancy patterns is based on the principle of carbonization. A fabric that contains both woollen and cotton fibres is taken and a figure or design is printed on it with a paste of aluminium chloride, the cloth being afterwards dried at a high temperature. The effect of this is that the cotton is destroyed in those portions of the fabric that are in contact with the chloride, and the cloth in those places becomes so impoverished as to produce a gauze or other delicate textile effect.

MACHINERY FOR CARBONIZING

MACHINES USED IN WET PROCESSES

75. Soaking Tanks.—In order to extract the vegetable matter from wool successfully by means of a chemical process, it is necessary to have suitable tanks for soaking the material in the carbonizing solution. For this purpose wooden tanks of an appropriate size are the most satisfactory, as they are not affected by the solutions and give a maximum of service with a minimum of cost. Round wooden tanks with iron hoops will stand the action of acid better and give longer service than square tanks as usually built with iron rods piercing the wood. Ordinary tanks lined with lead are also largely used.

76. The soaking tanks, or acid tanks, are usually sunk in the floor, in modern plants, and pipes are arranged to drain back into the tanks all acid solution thrown out of the material by

the hydro-extractors. The tanks are usually cube-shaped, and measure about 4 feet each way, inside. The material to be carbonized is packed fairly tightly in crates or cages of wood that fit loosely into the tanks, and a small overhead travelling crane is generally used to lower the crates into the tanks and to remove them to the hydro-extractors, the tanks and the hydro-extractors being arranged so as to facilitate this work. The crates may be made with side doors, or removable bottoms, to enable the material to be handled easily and rapidly. One hydro-extractor is sufficient to deal with the material from three or four acid tanks.

77. Arrangement of Carbonizing Plant.—A plan of a small modern carbonizing plant is shown in Fig. 13. There are two acid tanks *a* and *b*, the former containing a cage *c*. A travelling crane, not shown, lifts the crate from the tank and holds it suspended long enough to allow much of the acid solution to drain

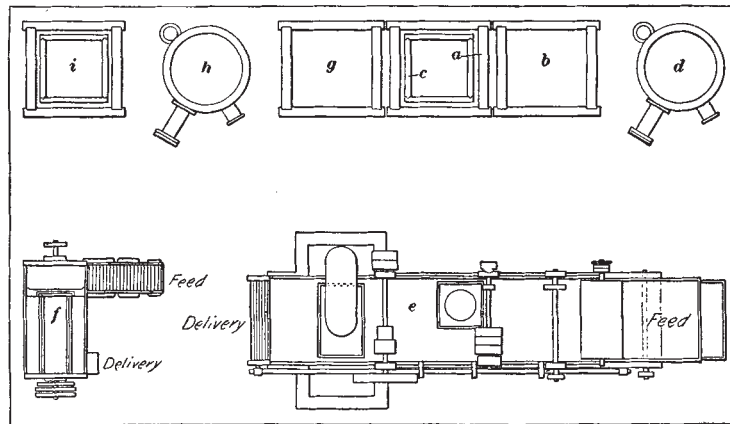

FIG. 13

back into the tank. The crate is then conveyed to the hydro-extractor *d* and the material is whizzed to free it from the greater portion of the remaining acid solution, from which it is taken to a dryer *e*. Here the carbonization is completed by drying or baking and the material is then taken to the burr-crushing and dusting machine *f*. When only one drying machine is used, it

is good practice to have the hottest air come in contact with the driest wool ; that is, the material should travel through the dryer in the opposite direction to that of the hot air.

78. After leaving the crushing and dusting machine *f*, Fig. 13, the material is carried to the rinsing tank *g*, through which clean water is constantly running, and from this tank it is taken to the hydro-extractor *h* to be whizzed. It then passes to the neutralizing tank *i*, where an alkaline solution neutralizes all acid remaining in the wool. The more efficiently the whizzing is done, the weaker may be the alkaline solution, thus effecting a saving in alkali. After being neutralized, the material is again taken to the rinsing tank *g* and thence to the hydro-extractor *h*. It is finally conveyed to an ordinary wool dryer, from which it emerges in a clean, soft, and lofty condition.

79. **Harrow Rake for Steeping.**—It is becoming more common in carbonizing plants to use the harrow-rake type of wool-washing machine for steeping the wool in the acid solution. When used for this purpose the machine should be lined with wood, so as to withstand the action of the acid. This machine may be used either with or without squeeze rollers. When no squeeze rollers are used, the material goes from the machine to a hydro-extractor; but when rollers are used, which is the preferable plan, the wool may be passed directly to a dryer without whizzing.

80. **Alternative Arrangement of Carbonizing Plant.**—A better arrangement of a carbonizing plant is to make the process continuous and thus obviate manual handling of the wool. In a line along one side of the room may be placed the following apparatus: A hopper feed feeds the wool to a steeping machine of the harrow-rake type fitted with squeeze rollers that deliver the wool by a lattice to a small drying machine, arranged to dry at a temperature of from 150° to 160° F. The drying machine delivers the wool to a second dryer of the same size, but having a temperature of from 180° to 200° F., in which carbonizing is completed. A lattice then takes the wool to a crushing and dusting machine that is arranged to deliver the material to a conveyer having a fan and suitable piping.

81. From the last machine of the line the conveyer takes the wool to a harrow-rake type of rinsing machine that forms the first of a series of machines in a second line, parallel to the first, but extending in the opposite direction. There is a current of clean water continually flowing through the rinsing machine, and on leaving this the material is passed through squeeze rollers to a lattice that conveys it to the neutralizing machine, also of the harrow-rake type. It then goes to another rinsing machine and is delivered to a dryer in which a temperature of about 160° F. is maintained. The wool emerges from the dryer, at the end of the second line of machines, in a soft, clean state.

82. Protection Against Acid Action.—The basket of the hydro-extractor should be lined with lead or be otherwise protected to render it acid-proof. In drying wool that has been treated with acid, it will be found impossible to use a dryer that has cotton lattices, as the acid will soon destroy the lattices. In the case of wool carbonized by aluminium chloride, the material can be dried with a multiple-lattice dryer with steam pipes between the lattices ; but with wool carbonized by sulphuric acid, the vapour of the acid will rust the iron pipes, and the wet rust dropping on the wool or the wool coming in contact with the pipes will result in stains. All metal in the dryer that comes in contact with wool that is saturated with acid must be lead-covered or otherwise protected.

83. Object of Duster.—After the wool comes from the dryer, the vegetable matter that was in the material before carbonization is greatly changed in character. Instead of being tough and clinging to the fibres of wool with great tenacity, the matter is brittle and may easily be crushed and shaken out of the wool. The object, therefore, of the carbonizing duster is to crush the burrs and other vegetable matter rendered brittle by the agent used in extracting and to remove them from the wool fibres.

84. Arrangement of Crushing Rollers.—A duster built especially for handling carbonized material is shown in Fig. 14. The material is fed by the lattice *a* to three pairs of heavy, fluted crushing rollers *b* that reduce the carbonized burrs to powder

before the material is subjected to the action of the rotating cylinder. The rollers are connected by gear-wheels and have springs and hand wheels *c* for controlling the pressure, which should be regulated so as to be heavy enough to crush the carbonized burrs, but not enough to cut the wool. The arrange-

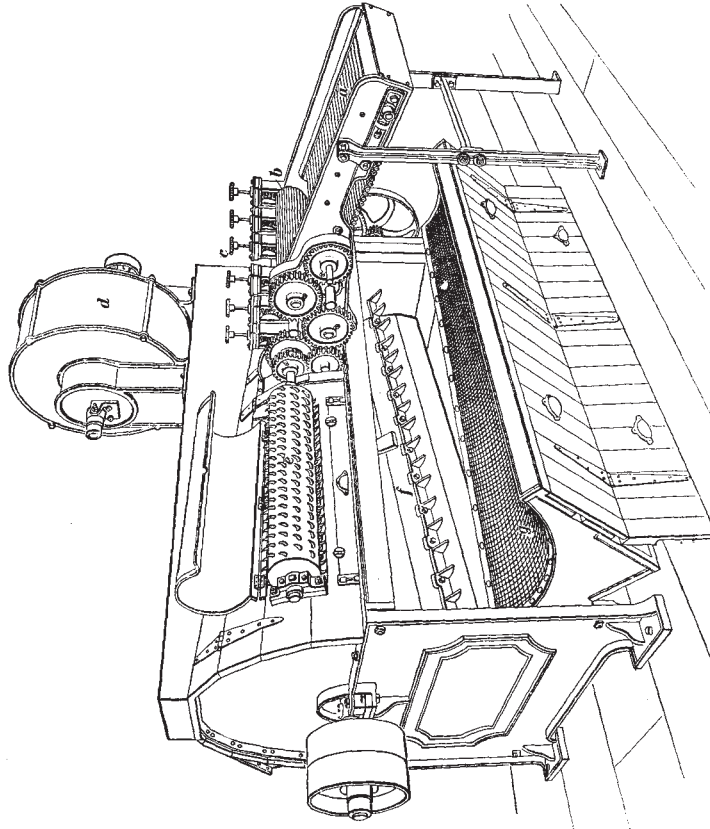

ment of the six rollers in this machine, and, in fact, in nearly all carbonizing dusters, is such that only three crushing points are obtained, as the rollers are arranged in pairs.

85. Another arrangement of crushing rollers is to have three bottom rollers and two top rollers, the latter resting between the bottom rollers, so that four crushing points are obtained,

although there is one roller less on which the pressure has to be regulated. If this arrangement is used, however, the springs for applying the pressure should be somewhat stronger, as the pressure is divided over two points instead of being concentrated at one. In most carbonizing dusters the crushing rollers are too narrow. A better method is to have wider crushing rollers, so that the material can be fed in thin layers. A better crushing will thus be obtained and none of the burrs will pass to the duster without being crushed. After passing the crushing rollers the wool can be directed to a narrow lattice feeding the duster. Sets of crushing rollers can be obtained entirely separate from a duster.

86. Main Cylinder of Duster.—From the crushing rollers the wool is delivered to the main cylinder to be acted on. The main cylinder is equipped with heavy iron teeth for beating the wool, and revolves at a speed of about 400 revolutions per minute, although a speed of 450 revolutions per minute is sometimes used when wool with a short fibre is to be treated. A longer fibre requires a slower speed, to prevent damage to the wool. The wool travels from the small end of the conical cylinder toward the large end and is finally thrown out at the rear of the duster.

87. Action of Duster.—The duster is sometimes built with a worker *e*, Fig. 14, that greatly assists in opening out the material. In operation, the worker rotates slowly backwards, its teeth engaging with the wool that is carried round by the main cylinder *f*. The worker is protected by a sheet-iron bonnet, which is shown raised from the worker. The fan *d* is on the top of the machine; and, since the space under the screen, which is beneath the main cylinder, is air-tight, the air drawn by the fan enters at each end of the main cylinder round the main bearings of the same, through apertures provided for that purpose. Beneath the fan there is a wire or perforated-metal screen or grid that retains the wool, being so made that it may be drawn out for cleaning. The air that passes through the upper portion of the machine sucks away light dust, etc., from the wool, while the heavy particles of dirt fall by gravity through the screen *g* under the cylinder. The screen is made in two sections, one of which

may be withdrawn from the front of the machine and the other from the rear.

88. Alternative Type of Duster.—Another type of burr-crushing and dusting machine that is somewhat similar to the foregoing consists of a lattice that feeds the wool to four pairs of fluted rollers, each pair of which is driven at a greater speed than the preceding pair, the wool in this way being gradually opened out and the burrs laid bare so that they are easily crushed while passing through. Close to the fourth or last pair of rollers is arranged a beater that revolves at a speed of about 240 revolutions per minute, and so shakes the material that the crushed or pulverized vegetable matter is completely sifted out. The beater is enclosed in a perforated cage, and on the top of the machine is placed a fan that draws away all the dust and leaves the wool in a clean and open condition.

MACHINES FOR EXTRACTING WOOL FROM RAGS

89. Methods of Extraction.—The two methods in use for reclaiming the wool from fabrics that contain both cotton and wool are the sulphuric-acid process and the hydrochloric-acid process, known also as the wet process and the dry process, respectively. The sulphuric-acid process, as employed for extracting wool from rags, is exactly like that used for carbonizing burrs in wool. The hydrochloric-acid process is very different from those processes in which the material is submerged in the liquid agent, and special machinery is used for carrying out the various operations.

90. Drying Chamber.—The rags containing both wool and vegetable fibre are sorted and graded so that those in each lot require approximately the same treatment. The rags to be treated are first placed in a brick drying chamber that has a perforated tray or wire screen 2 or 3 feet above its floor and of the same area as the chamber. On this the rags are piled to a depth of 10 or 12 inches. Along one side of the drying chamber are a number of doors, placed at suitable distances, through which the tray may be loaded or unloaded. Air heated by a coke-fired

tubular heater to a temperature of from 160° to 180° F. is led under the tray and is forced up through the rags by the action of a fan that draws air from the top of the chamber. This air is returned by a pipe to the heater to be reheated. After remaining in the drying chamber from 1 to 3 hours, the rags are bone dry and thoroughly heated, this drying and heating being essential to successful carbonization.

91. Carbonizing Box.—The rags on leaving the drying chamber are very hot, so the operatives wear long heavy gloves. The rags are loaded into large trolleys and conveyed to the carbonizing boxes, one of which is shown at *a*, Fig. 15. It consists of a box about 10 feet long and 6 feet square, constructed of thick iron plates bolted tightly together to make air-tight joints, and

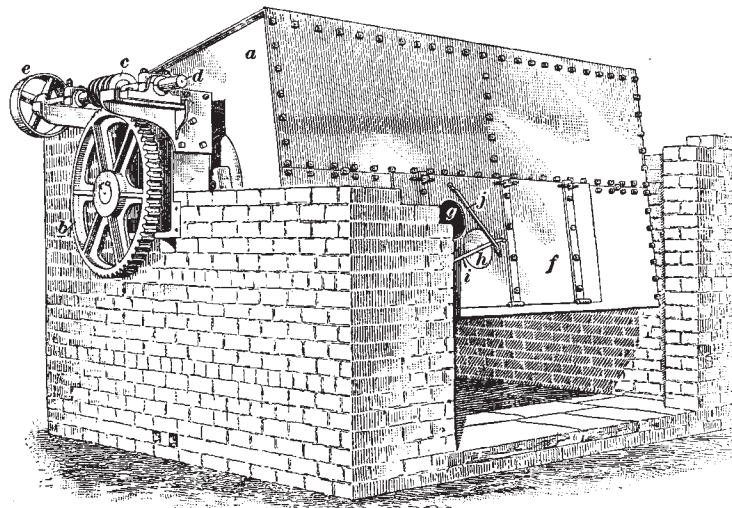

FIG. 15

supported on trunnions at the ends. One trunnion is solid and to it is keyed the worm-wheel *b*, which is driven by the worm *c* on the shaft *d* carrying the pulley *e*, thus causing the box to rotate. The other trunnion is hollow, and through it the acid vapour is passed into the box to act on the rags. The box rotates at a speed of from 3 to 4 revolutions per minute, or just

fast enough to keep the rags continually turning over and exposed to the action of the acid vapour.

92. Charging Carbonizing Box.—At the side of the carbonizing box is a hinged door *f*, Fig. 15, about 5 feet by 3 feet in size, that may be held tightly by wedges to ensure an air-tight joint all round. When the box is to be loaded, or charged, it is stopped in about the position shown, and the door *f* is let down. The rags in the box are then raked out and a fresh charge from the drying chamber is put in, after which the door is closed and the machine is restarted. About 5 or 6 hundredweights of rags is put in at one time. The hole *g*, about 8 inches in diameter, is used as a sampling hole. When the machine is running, the hole is closed by the plate *h*, which is fastened to a rod *i* pivoted at one end and sliding under a spring bar *j* at the other. To obtain a sample, the attendant waits till the door *e* comes round, when he seizes the rod *i*, slides the plate off the hole, inserts his hand to grasp some of the rags, withdraws it, and closes the hole. This can easily be done, as the box rotates very slowly. He then tests the rags by pulling them to ascertain whether the cotton in the seams, linings, etc., has been carbonized sufficiently to be quite brittle. If it has, the box is emptied and recharged. The time required for carbonization ranges from $2\frac{1}{2}$ to $3\frac{1}{2}$ hours, depending on the condition and nature of the rags.

93. Heating Carbonizing Chamber.—The brickwork supporting the carbonizing box in Fig. 15 is shown in the process of erection in order that the construction of the box may be seen. When the brickwork is completed the carbonizing box is entirely enclosed or built in, thus forming a chamber in which the box revolves, the chamber being heated by means of coke fires at each end, flues being arranged to conduct the gases to the chamber. The opening left in the front is generally closed by sliding iron doors, so that the gases from the coke furnaces are confined to the chamber and thus heat up the carbonizing box to the proper temperature. As carbonizing plants are usually run day and night, the whole of the brickwork and the carbonizing box become thoroughly heated and only comparatively small fires are necessary to maintain the proper temperature.

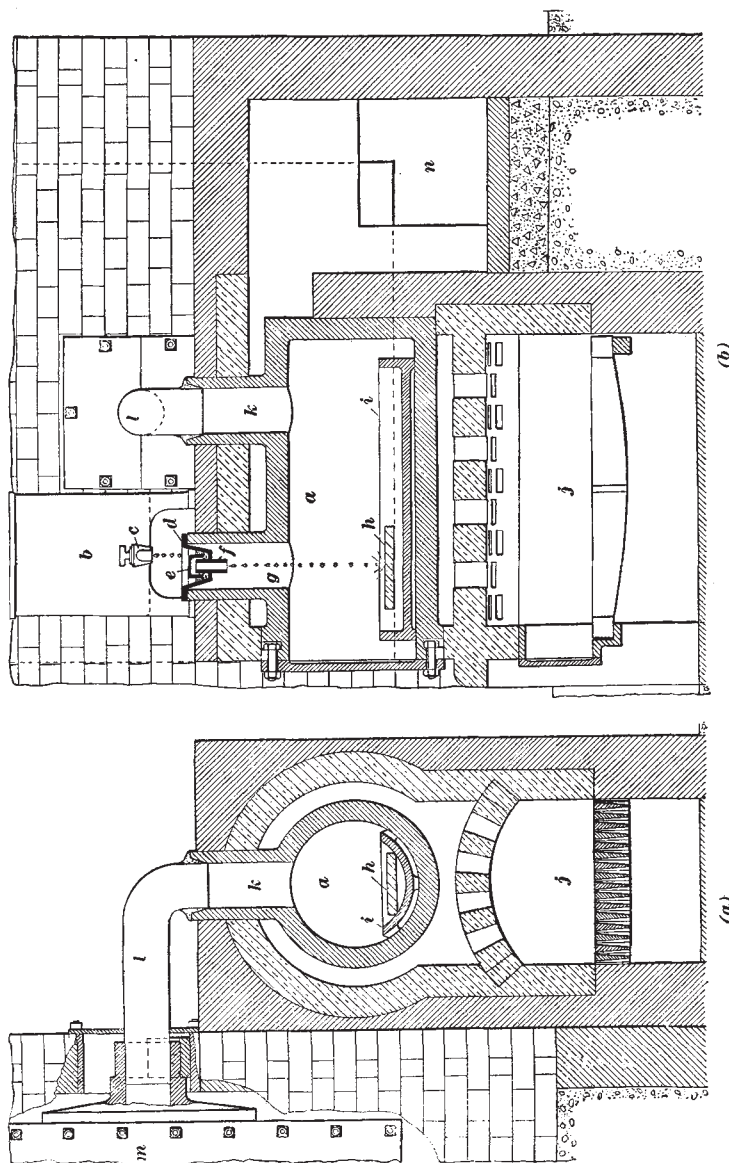

Fig. 16

94. Generating Acid Vapour.—The retort for generating acid vapour is shown in transverse and longitudinal section in Fig. 16 (*a*) and (*b*). The retort *a* is a thick iron cylinder supported at front and back by the brickwork that forms the heating furnace. It is about 18 inches in diameter and about 3 feet 6 inches long. The acid to be vaporized is contained in a vessel *b* and is allowed to drip from the cock *c* into the dish *d* of the vapour trap. A cap *e* is fixed over the end of the tube *f*, but is so large that it does not touch the tube. The acid accumulates in the dish until it reaches the level of the top edge of the tube *f*, when it overflows, dropping through the opening *g* on to the flat brick *h* in the dish *i*. A coke fire in the furnace *j* keeps the retort hot, as the gases of combustion almost completely surround the retort, and this heat vaporizes the acid, the vapour passing away through the outlet *k* and the pipe *l* to the carbonizing box *m*. The vapour cannot escape through the opening *g* as it has insufficient pressure to force its way down and out through the liquid sealing the lower edge of the cap *e*. The waste gases from the furnace *j* pass through the flue *n* to the carbonizing chamber and help to keep the carbonizing box hot. The dish *i* may be replaced when worn out by the corrosion due to acid, its purpose being to catch splashings of acid and to save the retort from corrosion.

95. Admitting Vapour to Carbonizing Box.—The acid vapour generated in the retort is led into the carbonizing box through the hollow trunnion. A small opening, about $\frac{3}{4}$ inch in diameter, is made on that side of the carbonizing box which contains the door, and a small puff of acid vapour escapes each time the side of the box containing the opening comes uppermost. This is to a certain extent an indication as to whether the retort is working properly or not. The small quantity of vapour that escapes into the brickwork chamber is drawn away by a large pipe in the top of the chamber, the pipe communicating either with a fan or with a tall chimney which causes a draught from the brickwork chamber; also, a draught is created through both of the coke furnaces, since their flues open directly into the brickwork chamber.

96. Passing Vapour to Open Air.—There is a practically constant but slight escape of vapour during carbonizing, a larger

escape when samples are taken out of the box, and a considerable escape when the carbonizing box is unloaded. But owing to the stringent laws respecting the passage of this vapour into the open air, it is necessary to remove the vapour by passing all the air drawn out from the brickwork chambers through a coke scrubber, consisting of a cylinder about 3 feet in diameter which is filled to a depth of 8 or 10 feet with coke, and through which a spray of cold water is constantly passing. All traces of the acid vapour are in this way absorbed, after which the air may be passed out through the chimney or by means of a fan into the open air and the acid water run down the drains. The quantity of acid required for each charge of rags will vary according to their nature and condition, but as a general rule from 4 to 5 gallons of acid is used for each charge of about 6 hundredweights of rags.

97. Construction of Wimsey.—When the rags are taken from the carbonizing box they must be well shaken, in order to break up the carbonized vegetable fibre ; but if the hot rags are taken

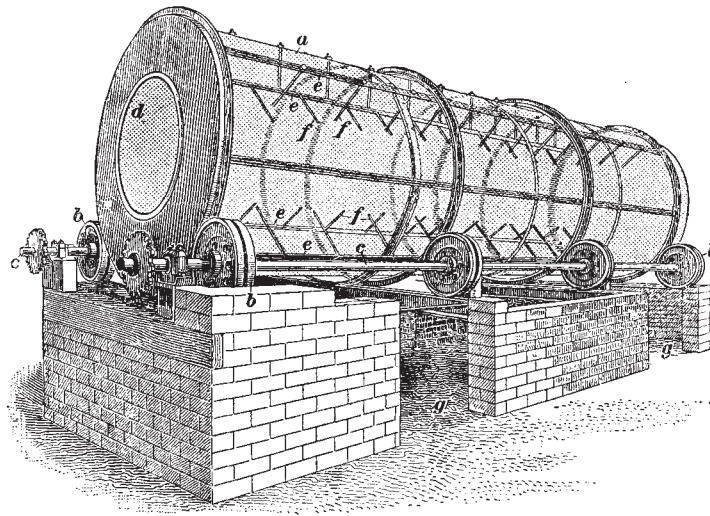

FIG. 17

direct to the usual type of enclosed rag shaker, there is considerable danger of outbreaks of fire, especially with rags that contain a large proportion of cotton or other vegetable fibre. With this

class of rags it is advisable, and, in fact, a distinct advantage, to run them through a machine termed a *wimsey*, which gives them a light preliminary shaking, cools them down, and at the same time rids them of the greater portion of the dust. The *wimsey*, which is shown in Fig. 17, consists of a large cylinder, or cage, *a* formed of wire netting suitably fastened to a framework, the whole being about 20 feet long and 6 feet in diameter. It is supported on two lines of rollers *b* that are fixed to and driven by horizontal shafts *c*, the latter receiving their motion from gearing not shown. The rags are fed into the end *d* of the cage, which is slightly higher than the delivery end, and the bars *e*, which run the length of the cage, are fitted with straight wooden rods *f* that project inwards toward the centre of the cage, as shown. As the latter revolves, the rods carry the rags up the sides and release them near the top, and as they drop they are slightly in advance of the point from which they started, owing to the slight inclination of the cylinder. Thus, they gradually work through to the delivery end of the machine.

98. Operation of Wimsey.—The continuous turning over and dropping of the rags loosens the carbonized fibre considerably and the heavier particles drop through the cage into the space underneath, the lighter dust being drawn out at the top by a powerful fan or by a connection to a tall chimney. The whole of the machine, except the ends, is enclosed in a brickwork chamber, and the feed end of the machine is partly enclosed, while the other end is partly covered up by a cloth suspended over the circular opening in the brickwork, leaving at the bottom an opening only about one-fourth the depth of the cage, through which the rags are dropped out on to the floor outside the chamber. Doorways *g*, Fig. 17, are made in the brickwork, the doors of which give access to the space beneath the cage so as to clear out the heavy dirt as it accumulates. After the rags have passed through the *wimsey* they are quite cool and are immediately taken to the rag shaker.

99. Construction of Rag Shaker.—The rag shaker, as illustrated in section in Fig. 18, consists of a cylinder *a* on the circumference of which are strong steel teeth, or spikes, about

3 inches long, set in plates screwed to wooden battens that in turn are securely bolted to the cylinder. The cylinder is mounted in suitable bearings supported by the upper framework of the machine and is enclosed by woodwork above the framing. About two-thirds of the circumference of the cylinder is surrounded by a perforated grid *b*, and a portion of the grid at the bottom is hinged on the pin *c* directly under the centre of the cylinder.

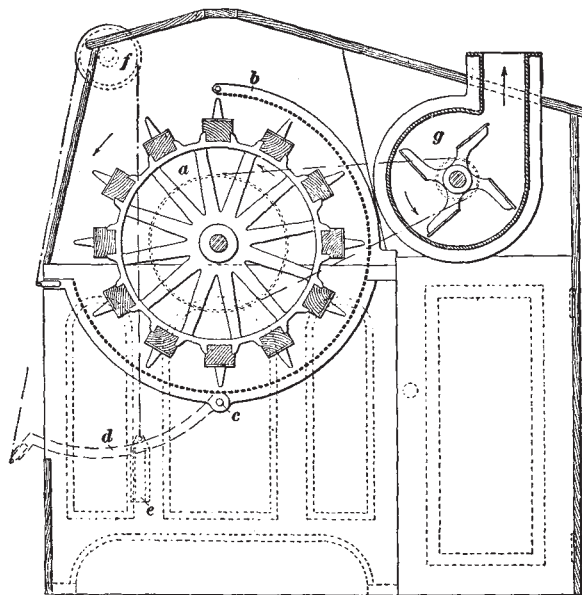

FIG. 18

This front portion can be lowered to the position indicated by the dotted lines *d*, for the purpose of loading and unloading each charge of rags, being balanced by weights *e* suspended from cords that pass over the pulleys *f*. These pulleys are supported by the wooden casing near the top, and are attached to the outer edges of the grid, there being one cord and one weight at each side of the machine.

100. Operation of Rag Shaker.—A quantity of carbonized rags from the wimsey is put into the machine, the hinged grid is closed, and the machine is set in motion. The rags are caught

by the rapidly revolving cylinder and whirled round and beaten against the grids, and at the front, where the rags are clear of the grid, they fly off the cylinder by centrifugal force. They strike against the casing, fall back, and are again caught by the cylinder and beaten against the grid in passing round, this action continuing until the rags are thoroughly beaten. As the rags are constantly turned over and over until every portion has been treated, all the brittle carbonized vegetable fibre is entirely shaken out. The heavy particles of dirt and dust fall into a box in the bottom part of the framework, from which they are periodically removed. The lighter dust is drawn out through the grid and blown from the machine by the action of the fan *g*, Fig. 18, which is placed at the upper back portion of the machine, and is driven from a large pulley on the end of the main-cylinder shaft by means of a belt, as indicated by dotted lines. When each batch, or charge, of rags has been sufficiently beaten, the hinged grid is dropped and the rags are ejected from the machine and taken to the **rag machine**, or, as it is usually termed, the **devil**, to be torn fibre from fibre to make shoddy or mungo, according to the nature and condition of the rags, the resulting material being subsequently manufactured again into yarn and cloth.

101. Production of Plant.—The production of a plant consisting of one dryer that will keep from 4 to 6 carbonizing boxes employed, with one wimsey and one rag-shaking machine, the carbonizing boxes running day and night, should be from 8 to 10 tons of rags per week of 6 days. This is on the basis of 6 charges for each carbonizing box per day, which allows an average of 4 hours for each charging, carbonizing, and emptying, on the basis of 6 hundredweights per charge. A few firms prefer the sulphuric-acid process and claim that they can obtain better results; but by far the larger proportion of the rags treated are dealt with by the hydrochloric-acid process, as no subsequent neutralizing is required.

OPENING AND MIXING

OPENING

WASTE WOOLS

CLASSIFICATION

1. Varieties of Waste and Recovered Wools.—In addition to the pure wool, and the mixtures of different classes or qualities of wool there is also a great number of lower qualities of wool produced by mixing with pure wool varying proportions of what may be termed **wool substitutes**. The term quality refers in this case to the fineness of the fibre, but if used in the worsted trade in conjunction with a number, it has a different meaning. In that case it indicates the count to which such material may be spun. The wool substitutes are used either as adulterants or as a means for giving cheap cloths an appearance similar to that of more expensive ones.

2. The different classes of wool substitutes may be classified as follows: (*a*) **Noils**, which are pure wool of short staple that has been combed out of longer-stapled material while the latter is being formed into a sliver. (*b*) **Waste**, produced while forming the sliver into yarn and cloth. (*c*) **New mungo** and **shoddy**, produced by disintegrating into threads and fibres the waste produced in merchant shops and by tailors, such as patterns and cuttings. (*d*) **Old mungo** and **shoddy** are produced by disintegrating rags from used clothing. (*e*) Material derived from cloth carbonized to remove sewing threads, or the cotton threads

woven into union goods. (f) Material derived from carbonized cloth consisting of wool substitutes manufactured into yarn that is woven into cotton warps to form a low grade of union cloth. This is one of the lowest classes of material.

The latter classes of wool substitutes, while originally derived from pure wool and answering all chemical tests applied to wool, are nevertheless lacking in some of the properties that make wool so valuable as a raw material in the manufacture of yarn and cloth.

3. Noils.—Wool, as grown on the sheep, is not of uniform length, and the process of manufacturing wool into worsted yarn necessitates the removal of the short fibres; such fibres are similar in their nature to the wool from which they are removed, but are generally somewhat finer in quality. In the process of combing noil out of wool, any burrs, seeds, shives, and so on, are combed out with it; consequently, unless the noil is from a wool that contains little of vegetable matter, it is full of such impurities. The impurities are, however, removed by carbonizing, the result being a pure wool material that is particularly useful in the woollen trade where short fibres are an advantage. In all other respects noils may be classed as pure wool. Besides the class of noil just described, there is another class produced that is known as *recombed*, which is always coloured, since it is obtained from tops that have been dyed and submitted to a second operation of combing. They are free from vegetable matter or oil, and as the lower quality of noil has already been taken out, the fibres constituting the recombed noil are of a greater average length and are in a more open condition. The merchants sort the noils that are received from the combers, and match the shades. Recombed noil is largely used in the better class fancy woollen trade, in the manufacture of fancy mixture yarns. It is mostly of a fine cross-bred or botany quality, since recombining is only practised in the manufacture of high-class fancy worsted yarns.

4. Soft Waste.—The waste resulting from the operations of spinning and weaving is a valuable by-product used in the woollen trade. The waste produced during the spinning process, or during the operation of manufacturing the material into yarn, is of two kinds, termed *hard* and *soft*. **Soft waste** is

made during the *drawing processes* when the slivers are but slightly twisted. The *drawing processes* are those of reducing a top or a number of tops to a thin sliver, termed a *roving*. The best quality of soft waste is that known as *laps*, or *roller laps*, and is made whenever an end breaks and runs round the rollers of the machine previous to its being pieced; this kind of waste is perfectly clean and consists of the best combed material, and consequently is quite valuable. When in its white state, it can be used along with wool, or as wool; when coloured, it is sorted, the shades being matched as with recombed noil. A second quality of soft waste is that known as *brush waste*, which consists of soiled laps or of light fibres that are brushed from the machines. This kind of waste is used in the low and medium shoddy trade; its value varying in accordance with the quality of the fibre. The fibre being of good length facilitates the spinning of shoddy, and being new wool it greatly helps the milling of the cloth into which it is woven, if this should be required. A still lower grade of soft waste is that which consists of floor sweepings.

5. **Hard Waste.**—Another distinct class of waste is that known as **hard**, or **thread**, **waste**, which is made in the operations of twisting, winding, and warping. The process of *twisting* is the operation of folding two or more single yarns together, while *winding* is the operation of transferring the yarn from one bobbin to another; the operation of *warping* is that in which a definite number of ends, all of the same length, are arranged to form what is termed a *warp*. The waste obtained from these operations is generally clean, but the threads require opening or reducing to a fibrous mass by means of a machine known as a Garnett machine. The waste obtained from the operation of *weaving*, which is the operation where a fabric or cloth is formed by interlacing warp and weft threads, is termed **weavers' waste**, and is always hard. This kind of waste must be made into a fibrous mass, either by a rag machine or a Garnett machine. The hard waste is also used in the low and medium shoddy trade, but being less valuable than the soft waste, it is used in a lower class of goods.

WASTE-OPENING MACHINERY

KNOT-BREAKER

6. **Function of Garnett Machines.**—The machines necessary for opening hard-thread waste may be separated into two distinct types: the first is termed the *preparer, knot-breaker, or rough Garnett machine*; the second is termed the *Garnett machine*. The first type is designed to do the initial work of opening, such as the breaking of knots, the removal of hard pieces of leather, nails, and so on, before the material is passed to the Garnett machine. The rollers and cylinders of these machines are covered with saw-tooth, or Garnett, wire, which, as it is made from tempered steel, will retain its point for a long time, if ordinary care is taken.

7. **Construction and Operation of a Knot-Breaker.**—Figs. 1 and 2 are elevations of the two sides of a knot-breaker, with a portion of the casing removed to show the interior. It consists essentially of a cylinder d , Fig. 1, workers f , and doffing brush-fan g , with suitable feed-mechanism, the working parts being enclosed by a cover h ; the cylinder and workers are covered with coarse Garnett wire, there being 8 to 12 rows per inch. The material is laid by hand on the feed-lattice, indicated by the side plates a , and is carried to a pair of slowly revolving, plain, press rollers, indicated by their journals at b, b_1 ; these rollers are about 3 inches in diameter. The material then passes to the feed-rollers c, c_1 , which are 4 inches in diameter and clothed with Garnett wire; they revolve with the backs of their teeth first, so as to retain the material as long as possible while the cylinder d is acting on it. This cylinder is $24\frac{1}{2}$ inches in diameter and revolves at a high speed with the points of its teeth first, so as to tear the material from the feed-rollers.

8. Any material that passes round with the top feed-roller c_1 is cleared by the brush e , which replaces it on the cylinder. The material as it continues its journey with the cylinder comes under the action of the slowly revolving first worker f , and while

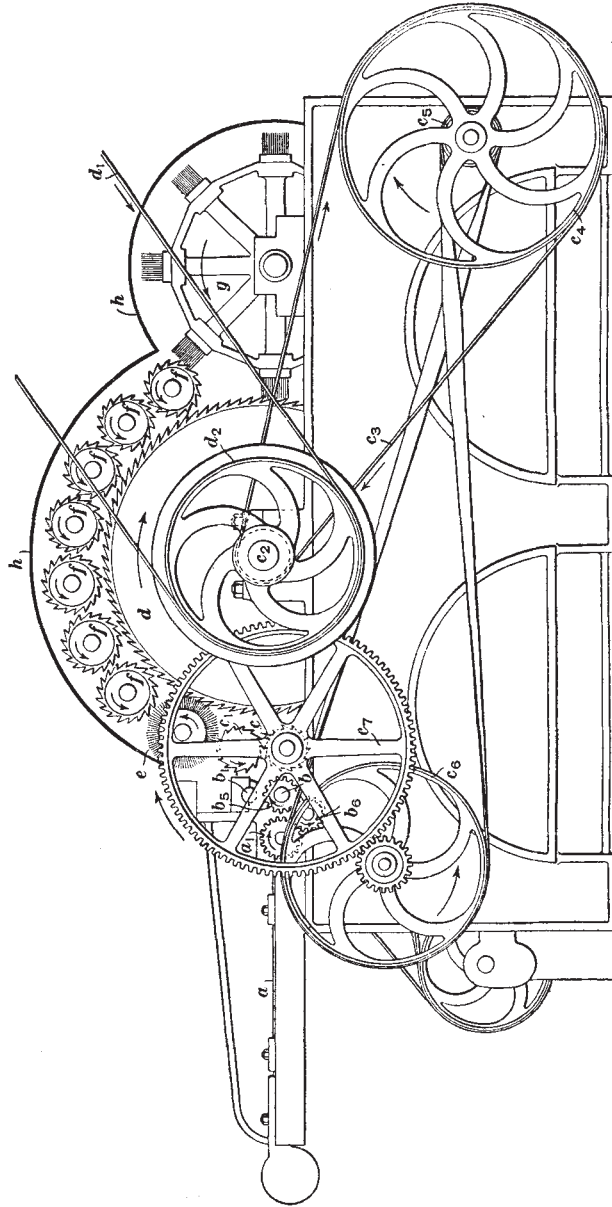

FIG. 1

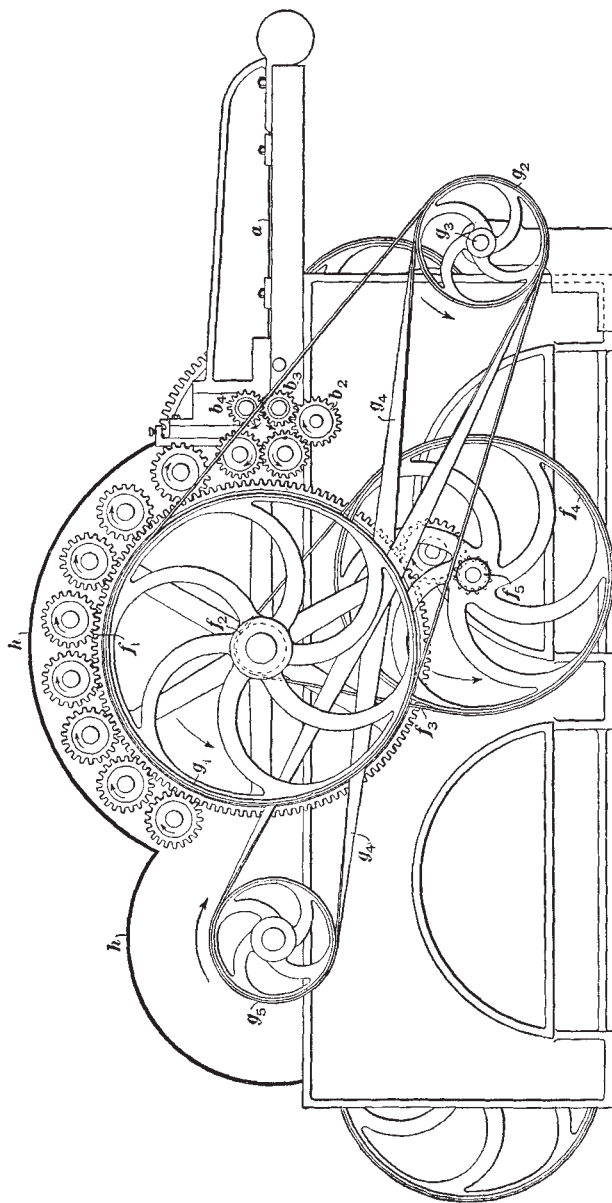

FIG. 2

the cylinder retains its hold on some part of the material and draws it through the teeth of the worker, it is subdivided, or opened. All the workers have a similar action and, being set progressively nearer to the cylinder, their holding and opening power become gradually greater. The workers are $4\frac{1}{2}$ inches in diameter and are set so as to just touch one another; therefore, each worker is stripped by the succeeding one. The cylinder and the last worker are cleared by the doffing brush g , which is 20 inches in diameter. This brush also acts as a fan and as such blows the material out of the machine in a loose condition.

9. Driving.—A belt from the line shaft drives the fast pulley d_2 , Fig. 1, placed on the cylinder shaft, at a speed of about 450 revolutions per minute. The doffing brush g is driven at a speed of about 1,100 revolutions from a pulley g_1 , Fig. 2, at the other end of the cylinder shaft, which drives by means of a double carrier pulley g_2 , revolving loosely on the stud g_3 , the pulley g_5 , fixed on the doffing-brush shaft. The workers are driven at a speed of about 30 revolutions per minute by a large gear-wheel f_1 that revolves loosely on the cylinder shaft, and is given a slow, rotary motion in the same direction as the cylinder by a small pulley f_2 fixed on the cylinder shaft, which by belt f_3 drives pulley f_4 ; the latter pulley carries a pinion f_5 which, through a carrier wheel, gives motion to the large gear-wheel f_1 . The brush e is also driven from wheel f_1 in a similar manner to the workers. The feeding mechanism is driven by a pulley c_6 which receives its motion from pulley c_5 , compounded with the pulley c_4 . Fastened to the pulley c_6 is a pinion which drives the gear-wheel c_7 , placed on the shaft of the bottom feed-roller c ; the top feed-roller is driven by gear-wheels of equal size on the other side of the machine, Fig. 2. The press rollers are driven by carrier wheel b_2 , which drives gear-wheel b_3 on the bottom press-roller shaft; the top press roller receives its motion from b_3 by means of the wheel b_4 . The feed-lattice is driven from wheel b_5 , on the lower press roller b , Fig. 1, which through carrier b_6 gives motion to the gear-wheel a_1 on the end of the front roller of the lattice. Machines with cylinders 24, 36, or 48 inches long will produce about 60, 90, or 120 pounds per hour, respectively.

GARNETT MACHINE

10. Construction and Operation.—The Garnett machine may be said to reduce to a fibrous condition the waste that has been opened out by the knot-breaker. This machine consists of 1, 2, or 3 cylinders, with component parts, the one with 3 cylinders being mostly used.

Side elevations of this machine are given in Figs. 3 and 4, parts of the casing being removed to show the interior parts. In operation, the material is fed by a hopper feed to the feed-lattice, situated at *a*, which carries it to the first pair of feed-rollers *b*, which are fluted, as shown in the detail views, Figs. 3 (*b*) and 4 (*b*); from these the material is passed to the second pair *c*, which are covered with strong Garnett wire. The latter feed the material to the first licker-in, or tumbler, *d*, which is 12 inches in diameter; the licker-in prevents any hard bits from reaching the 30-inch cylinder *e*, Fig. 4, which clears, or strips, it. The teeth on these rollers and their direction of rotation are clearly shown in Figs. 3 (*b*) and 4 (*b*). A fluted roller situated at *f*, Fig. 4 (*a*), below the feed-rollers, works in conjunction with the latter and the first licker-in and assists in making the feeding even.

11. A second licker-in, or worker, *g*, Fig. 4 (*a*), which is 9 inches in diameter, works in conjunction with the licker-in *d* and, as it revolves more slowly, helps in opening the material and in ensuring even feeding. The lickers-in *d* and *g* are stripped by the cylinder *e*, which carries the material to the first of a series of 11 workers *h*, each of which is 4 inches in diameter. This and the other cylinders are covered with fine Garnett wire, so as to make about 30 rows per inch. The workers are set to the cylinder by gauge, the size of the gauge used depending on the class of material to be worked; each worker is stripped by the succeeding one. A fancy *i*, Fig. 4 (*a*), which is 11 inches in diameter and revolves at a great speed with the points of the teeth first, lifts the material out of the cylinder. The fancy stripper *j*, which is 6 inches in diameter and works point against point of the fancy, ensures that the material is laid back on to the cylinder. The material is then received by the doffer *k*,

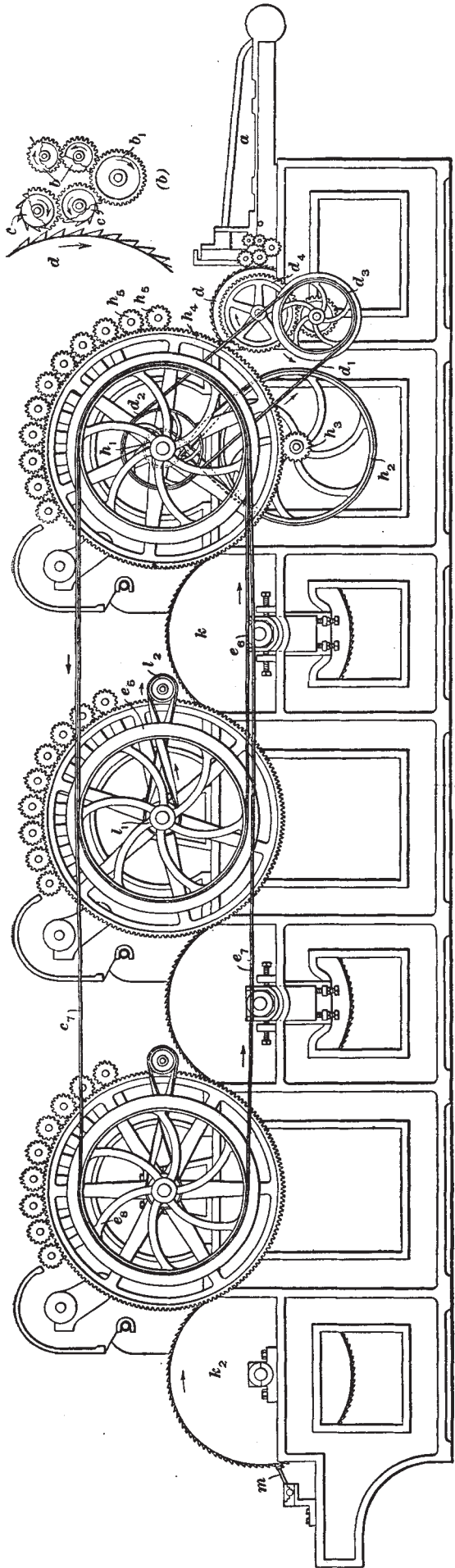

FIG. 3

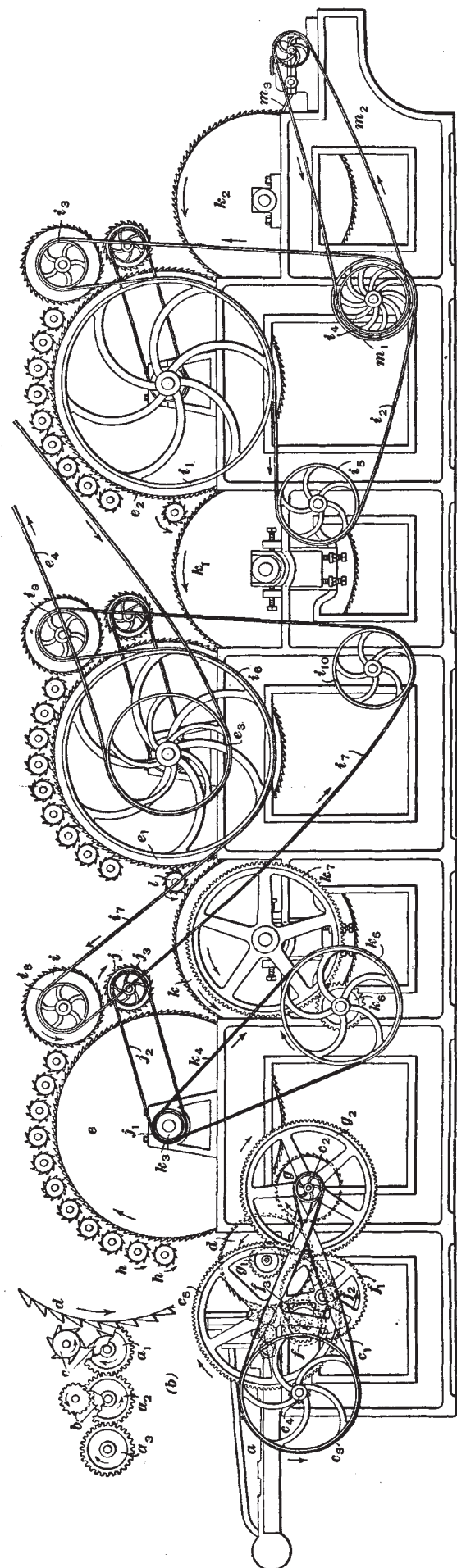

FIG. 4 (a)

Rotated 90° degrees to fit on page.

24 inches in diameter, which carries it round to the *angle stripper* l , 4 inches in diameter, which removes the material and transfers it to the second cylinder e_2 . The operation of working and stripping is repeated on the cylinders e_1 and e_2 and doffer k_1 ; when the material finally reaches the last doffer k_2 , it is stripped by the doffing comb m_3 and removed for the purpose of being mixed with other materials, as required, previous to its manufacture into yarn. The first and second doffers may be adjusted both in a horizontal and vertical direction, and can thus be set to work in conjunction with both the cylinders between which they are placed, in this way increasing the efficiency of the machine. The fancy may also be adjusted in two directions, so that it may be set to both the cylinder and last worker.

12. Driving.—The pulley e_3 , Fig. 4 (*a*), on the shaft of the cylinder e_1 , is driven by belt e_4 from the line shaft at a speed of about 285 revolutions per minute. Motion is given to the cylinders e and e_2 by side pulleys placed on their respective shafts on the left-hand side of the machine, as shown in Fig. 3 (*a*). Thus, cylinder e is driven from a pulley e_5 on the shaft of cylinder e_1 by means of a belt e_6 , and cylinder e_2 by means of pulley e_8 and a belt e_7 , which passes over side pulley e_5 and belt e_6 and round the side pulley on the shaft of cylinder e . The licker-in d , Fig. 3 (*a*), is driven at a speed of about 90 revolutions per minute by the pulley d_2 on the shaft of cylinder e , a belt d_1 from pulley d_2 on the first cylinder shaft driving pulley d_3 compounded with a pinion wheel that drives the gear-wheel d_4 on the shaft of the licker-in. The licker-in g , which revolves at a speed of about 12 revolutions per minute, receives its motion by means of a wheel g_2 from a gear-wheel g_1 , Fig. 4, on the shaft of the first licker-in. The fluted roller at f is driven from gear-wheel g_2 , through large and small carrier wheels f_1 and f_2 , respectively, the latter driving gear-wheel f_3 on the shaft of the roller.

13. The feed-rollers are driven by belt c_1 from pulley c_2 , Fig. 4, on the second licker-in shaft, which drives the pulley c_3 , compounded with a pinion wheel c_4 ; the latter drives wheel c_5 on the bottom feed-roller shaft c . The top feed-roller is driven

from the other side of the machine by gear-wheels of equal size. The feed-rollers b are driven by carrier wheel b_1 from the gear-wheel on the bottom feed-roller shaft c , as shown more clearly in Fig. 3 (b). The feed-lattice is driven from the bottom feed-roller c by gear-wheel a_1 , Fig. 4 (b), which through carrier a_2 , that revolves loosely on the bottom feed-roller shaft, gives motion to gear-wheel a_3 on the front roller shaft of the feed-lattice. The driving mechanism for the workers is similar for each cylinder; in the case of the first cylinder the pulley h_1 , Fig. 3 (a), drives by crossed belt pulley h_2 compounded with the pinion wheel h_3 which drives the large gear-wheel h_4 . This revolves loosely on the shaft of the cylinder, and drives the workers at a speed of about 30 revolutions per minute, through gear-wheels h_5 , one of which is fixed on each worker shaft.

14. The fancy for the cylinder e_2 is driven from a pulley i_1 , Fig. 4, termed a *body pulley*, by means of the belt i_2 and pulley i_3 on the fancy shaft; carrier wheels i_4 and i_5 ensure a sufficient belt contact on pulley i_1 . Compounded with the carrier wheel i_4 is a band pulley m_1 , which by band m_2 drives the doffing comb m_3 . The fancies for the cylinders e and e_1 , respectively, are driven from body pulley i_6 , on the shaft of cylinder e_1 , which by belt i_7 gives motion to pulleys i_8 and i_9 on the shafts of these fancies. The fancies are driven at a speed of about 1,350 revolutions per minute. The fancy strippers are driven at a speed of about 200 revolutions per minute; they receive their motion from a pulley on the cylinder shaft, thus pulley j_1 drives by a belt j_2 the pulley j_3 on the end of the fancy stripper shaft. Each angle stripper l is driven from the cylinder shaft by means of pulleys l_1 and l_2 , Fig. 3 (a), at a speed of about 300 revolutions per minute.

15. Each doffer is driven from the cylinder from which it receives material. The drive for the first doffer is shown in Fig. 4 (a), where a pulley k_3 , fixed on the first cylinder shaft, drives by a belt k_4 pulley k_5 compounded with a change wheel k_6 that drives doffer wheel k_7 . A machine of the type shown, 36 inches wide, that is, with cylinders 36 inches long, will produce about 200 pounds per day of 10 hours; for machines

48 and 60 inches wide the production will be about 260 and 320 pounds per day, respectively.

16. Modified Garnett Machine.—A modification of the preceding Garnett machine is shown in perspective in Fig. 5; Fig. 6 is a diagrammatic section with the feeding mechanism and front part of the first cylinder omitted. In the type illustrated by Figs. 3 and 4 the doffer is not able to clear the cylinder entirely, hence the material may pass round the cylinder more than once and thus be subjected to an extended action of the workers, which may result in reducing the length of the fibres. To overcome this difficulty the doffers, except the last one, are replaced by

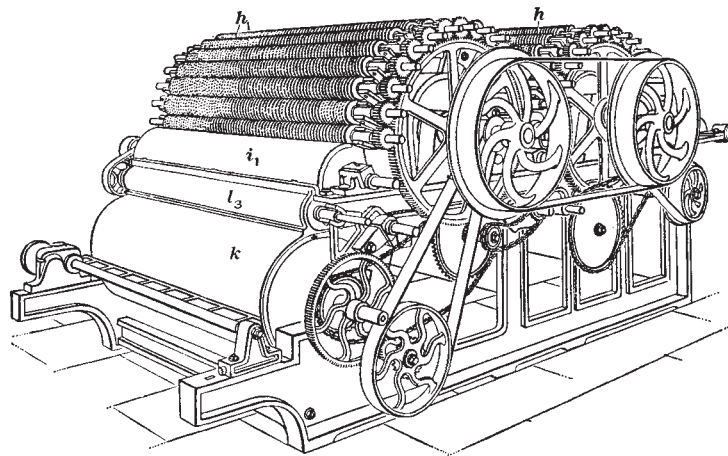

FIG. 5

fancies, which are placed below the centres of the cylinders so as to make room for an additional number of workers. Thus, instead of having 3 cylinders with an aggregate of 25 workers, as in the older model, the later one has the same number of workers operating in conjunction with only 2 cylinders.

17. The partly opened material is removed from the cylinder e , Fig. 6, by the fancy i , which revolves at a higher surface speed. The material on the fancy is removed by the slower revolving strippers l and l_1 , both being cleared by the cylinder e_1 , on which the opening action is continued by the workers h_1 until the

material is removed by the fancy i_1 . The strippers l_2, l_3 clear the fancy and deliver the material to the doffer k , from which

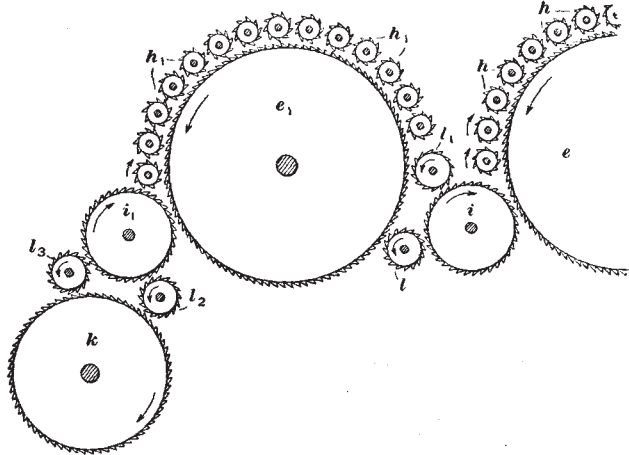

FIG. 6

it is finally removed by a doffing comb in the usual way. The general arrangement of the parts and the principal features of the driving mechanism may be seen from Fig. 5.

MUNGO AND SHODDY

18. **Characteristics of Mungo and Shoddy.**—Rags, as they are received by the merchant, are primarily arranged in three great classes: (a) Those which contain only animal fibre. (b) Those which contain both animal and vegetable fibre. (c) Those which contain only vegetable fibre. The rags in the first two classes can be utilized in what is termed the low woollen trade. In the process of transforming the rags into a condition of threads or fibres, the fibres are much reduced in length as a result of the pulling action of the machine, the fibres not separating readily by reason of the structure of the fabric and the interlacings of the fibres in twisted yarn. The fibre besides being broken is also badly bruised, causing the scales to be lacerated and broken off. Naturally, the spinning and milling properties of the fibre are greatly reduced.

19. In a technical sense *mungo* and *shoddy* are two distinct classes of material, **mungo** being produced from rags of a hard milled nature, while **shoddy** is obtained from rags that have not been milled. In practice this distinction does not always hold true, probably because of the almost endless varieties of fabrics that are now used. All cloths or rags of a botany quality, that is, cloths that have been made from merino or similar wool, are used in the mungo trade ; while rags that are coarser and which are made from wools of a cross-bred or English quality find their way to the shoddy manufacturers. Mungo and shoddy are somewhat softer in handle than the same grade of wool ; the former are also duller in appearance, and as wool is almost invariably dyed before it reaches the finished cloth, they are almost always coloured. The use of the terms shoddy and mungo varies in different localities ; thus, in some localities both materials are termed mungo, while in other localities they are termed shoddy.

20. **Classification.**—Before the distinctive features of mungo and shoddy can be understood, it is necessary to consider the sources of supply. Every variety of cloth possesses a distinctly recognizable quality, but since the varieties of cloth are endless, it is necessary to group similar kinds together. It is impossible to describe all the various qualities of mungo and shoddy, but the following typical examples will indicate in outline the course of procedure in sorting or classifying. In the manufacture of wool into cloth there are three distinct types of fabric made: (*a*) That in which the material has been made into hosiery or knitted goods ; (*b*) that in which it has been made into worsted cloth ; (*c*) that in which it has been made into woollen cloth. These are the three groups into which rags are sorted ; but this is only the preliminary of a long series of classification. Sorting or classifying is necessary in order that the material may be fairly uniform in quality and so that better results may be obtained in the remanufactured cloth ; further, when it is stated that shoddy varies in price from under 1d. to over 1s. per pound, the necessity for sorting is evident.

21. **Sorting Knitted Goods.**—The group that consists of knitted goods, which in practice are always termed stockings,

whether consisting of stockings, jerseys, or scarfs, are graded into four qualities according to the number of yarn that may be spun from the raw material used in their manufacture. The classes are as follows: (a) Wool below 24s generally derived from imported rags that pass by the name of *Russian*; these form one of the few classes that have been made up and worn in the undyed state, and are usually of a light natural grey or white colour. (b) The bulk of the stockings made, however, are comprised in the next finer quality, which ranges between 28s and 44s; this quality is termed the *medium* or *Scotch* quality, and supplies a good, lofty shoddy, nearly free from kempy fibres. (c) Finer still are the fine stockings, which are included in the qualities ranging from 44s to 56s. (d) The best qualities are the botany qualities, or *Berlins*, which are used as mungo, though the material is of a higher class than the general run of mungo.

22. Each one of the above four qualities may be further subdivided into various classes in accordance with the nature of the material. In the Scotch quality, for instance, the best classes are made from a worsted yarn, which gives a long-fibred, curly shoddy. An imitation of the Scotch quality, particularly prevalent when wool is high in price, consists of worsted and coloured-cotton twist yarns. These have a similar appearance to the pure worsted, but the presence of the cotton makes this class unsuitable for any but a very low grade of cloth; when carbonized, however, the wool can be suitably mixed and gives good results. Many stockings are made from woollen yarns, and since shoddy may form a constituent of such yarns, they may be low in quality, that is, short in staple and lacking in brightness and elasticity. A still lower class, but one belonging to the Scotch quality, is termed *angola* stockings; these are made from a yarn composed of a mixture of wool and cotton.

23. After being classified according to the nature of the material the various classes are sorted according to colour. For example, from the rags constituting a medium quality class of worsted stocking a large range of shades is obtained. First, the stockings containing two or more colours, such as heather

mixtures, twist yarns, or narrow striped stockings, the colours of which could not very well be cut away to form a distinct class, would be sorted and termed *fancies*. These would form a sort of no particular colour, but rather a mixture of many, and could therefore be used only for forming yarn and cloth to be dyed dark shades. Any rags containing black as a colour are kept separate from those without any black, as the latter, by reason of their lighter colour, are more valuable, since it is possible to dye them a greater range of colours than the former, which are only suitable for navy and black shades.

Distinction is also made between similar colours in the one-colour varieties. For example, there are two kinds of black, one that is termed a *dead* black, which is the best, and the other, termed a *faded* black, which may be redyed. Stockings of a blue colour are sorted into *best* blues, *faded* blues, and *indigo* blues; these classes are always in great demand. Separate colours form distinct sorts and special lines, some of which are steel greys, silver greys, drabs, and so on; the value of these sorts depends on whether they can be dyed when in the piece into bright, light shades, or whether they can be used to give a clean mixture.

24. By reason of the almost unlimited varieties of shoddy, it is possible to comply with any special requirement made by the manufacturer. For special purposes the rags may be *seamed*, that is, every trace of cotton sewing thread cut away, and all rags containing cotton rejected or carbonized. For a very good shoddy the feet of the stockings would be cut off and only the legs or *tops*, as they are termed, used, since the latter are practically unworn. No limit can be indicated as to the sorts that are made from stockings. Speaking generally, stocking shoddy is more like natural wool than most other kinds, which is largely due to the artificial curl given to the yarn during knitting; stocking shoddy has a curly and lofty nature that is lacking in most of the other varieties. This quality makes it a fairly good spinning material, but one that is seriously deficient in milling properties, due in some measure, perhaps, to the many washings received, the chemical treatment to which hosiery is often subjected to prevent shrinkage, and the natural absence of milling power in

the wool used for hosiery yarns. On this account it is generally mixed with wool or waste, when it becomes capable of making a cheap and durable cloth that is smart in appearance.

25. Sorting Worsted Rags.—To the second group of rags belong those coming from worsted cloth. These are sorted in the same manner as the stockings, in the following groups: (*a*) *Coarse*, which comprise cloths termed damask, flag cloths, and so on; the cloths in this group are composed of materials having a long straight fibre; (*b*) *medium*, consisting principally of dress and coating serges, the bulk of which are navy blue and black in colour; (*c*) *fine*, comprising fine worsted coating cloths which make a superior quality of mungo.

Each of these groups is divided into two classes, those containing cotton threads being separated from those without. Quantities of serge cloths are made, however, from worsted warp and woollen weft, but these are generally classed as worsted cloths, as they are cheaper and difficult to detect in the shoddy. It is to be noted in connection with this group that a valuable shoddy is obtained from flag cloths, on account of the fast dye that has been used. Damasks are sorted as fancies, and coating serges are usually sorted according to colour, the principal of which are fast black and blue colours. The range of shades obtainable in this group is more limited. Worsted shoddy has the disadvantage of possessing a very straight fibre, due largely to the continual straightening to which it is subjected during its previous manufacture into yarn; consequently its spinning property is indifferent, as compared with shoddy produced from stockings. It is possible to manufacture a very solid yarn, that is, one of small diameter compared with its count, from worsted shoddy, and the better qualities will mill fairly well.

26. Sorting Woollen Rags.—The rags forming the third group offer a greater variety than the second group, since they are often adulterated with material that has been remanufactured. They may be separated into the following groups: (*a*) Cloths constituting the *coarse* quality, which are coarse and kempy in character, and always of fancy colours, since they consist largely of what are termed homespun suiting cloths. A large quantity

of coarse, light, natural grey rags is imported from Russia and are similar in quality. (b) The *medium* quality consists largely of tweed cloths, which are sorted into light and dark sorts. (c) The *fine* quality comprises fine woollen cloths from which the real mungo of Batley and Leeds is made, and which may be said to include all fine-milled cloths, such as overcoatings, beavers, meltons, and so on. Compared with a proper shoddy, mungo is short in fibre, and mostly too short to card on machines constructed for carding shoddy; it is also very fine in fibre and mills fairly well. Shoddy obtained from woollen cloths is curlier than that obtained from worsted cloths, but is shorter in staple, quality for quality. Flannel cloths, although fine, are always classed as shoddy.

27. New and Old Shoddy and Mungo.—Cloth rags are subjected to a further division according to whether they are new or have been derived from worn clothing. The material obtained from the former is termed *new* mungo or shoddy and the chief sources of supply are tailors' cuttings and patterns. This product more nearly resembles the original wool in its properties than does that obtained from worn clothing. It is also brighter, loftier in handle, longer in fibre, cleaner, spins and mills better, and is practically free from dirt, the presence of which often causes a loss in the original weight of up to 20 per cent. in carding and spinning. It must be noted that in sorting care must be taken to remove all hard substances, such as hard trimmings, hooks and eyes, buttons, and so on, as the presence of these have a bad effect on the rag machine and are liable to cause fire.

DUSTING OF RAGS

RAG SHAKER

28. Construction.—Rags often contain a great deal of dust and dirt; therefore, for the comfort of the workpeople and the advantages derived in subsequent processes, it is removed in a machine termed a rag shaker. This machine, which is shown

in perspective in Fig. 7 and in a longitudinal section in Fig. 8, consists of a box-like iron framework, in which is fitted a revolving cylinder *b*, made to revolve at a speed of about 600 revolutions per minute by means of pulleys and belt, not shown. The length and diameter of the cylinder is 36 inches; it consists essentially of eight transverse bars *b*₁, through which are bolted strong teeth that project 3 or 4 inches. Round the cylinder is placed a coarse grating *c* through which dirt, beaten from the rags by the cylinder, will pass through. An exhaust fan *d*, which

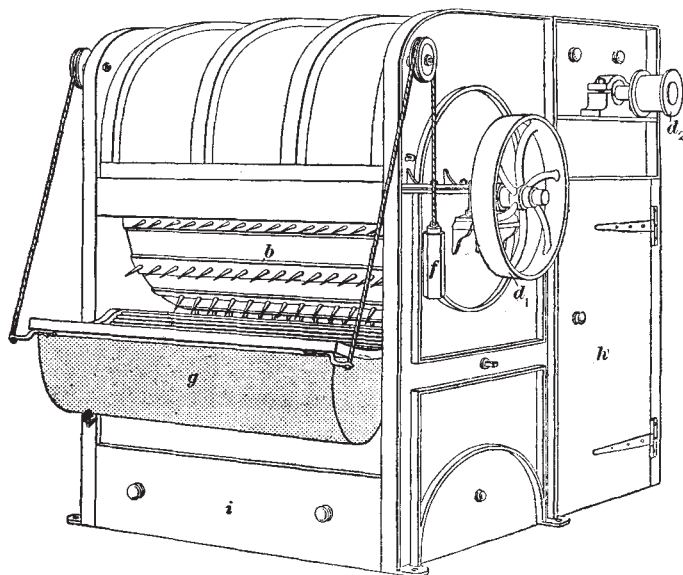

FIG. 7

is driven at a speed of 1,000 to 1,200 revolutions per minute by means of a belt from pulley *d*₁ on the cylinder shaft to pulley *d*₂ on the fan shaft, draws away the lighter dust and dirt through the tube *d*₃.

29. Operation.—The material is fed to the machine, Figs. 7 and 8, by placing it on the lowered door *e*, which is a continuation of the grating *c*, but hinged at *e*₁. When the door is closed the rags are thrown on to the cylinder which carries them round and beats them thoroughly against the grating. The door is kept

closed by the balance weights *f*, a canvas or leather cover *g* preventing dust from coming out at the front. In a short time the attendant lowers the door and the cylinder ejects the cleaned rags. The heavy dirt removed by the cylinder falls through the grating into the bottom of the machine, from which place it

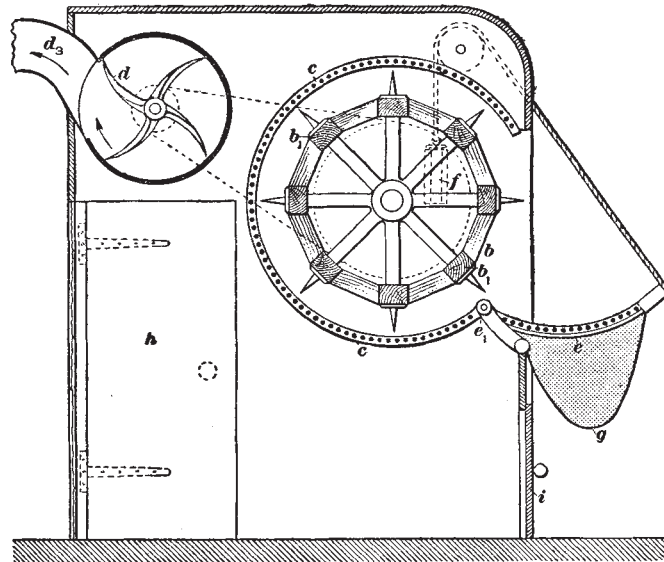

FIG. 8

is removed at intervals, partly through the door *h* and partly through the opening obtained by removing the board *i*. The machine described is largely used; but machines are now made which are fitted with feed- and delivery lattices, so that all danger of accidents to the attendant working near the cylinder is obviated.

PULLING OF RAGS

RAG MACHINES

30. Preparing Material for Pulling.—The process by which rags are reduced to a fibrous condition is termed *pulling*, or *grinding*. Preparatory to this process the rags are spread out

in layers in a space of about 10 feet square and oil is applied to each layer to facilitate the pulling. This arranging of the rags into layers gives an opportunity for their thorough mixing as to colour and quality, and the process is therefore called *blending*, or *mixing*. It also serves as a means for combining different qualities, so as to produce a blend of a certain price, and, incidentally, also as a means for adulteration, that is, by including inferior material for the purpose of increasing the profit. Soap, or a mixture of sodium carbonate and water, is often added to the oil and an emulsion formed. The bulk of the water is evaporated during the pulling process, owing to the heat generated, but the presence of the water tends to keep the temperature of the material within certain limits and thus prevents the oil from evaporating. Considering a quantity of rags weighing 240 pounds, called a *pack*, it will require about 2 gallons of oil and 2 gallons of a solution of sodium carbonate to prepare the material for pulling; sometimes 3 gallons of oil is used without water. Inferior grades of oil, as black cloth oil, or brown cloth oil, are often used without any water on low-grade materials; on better class materials oleine or oleine emulsions are generally used. The oil is applied by means of an ordinary can holding about 3 gallons and provided with a **T**-shaped nozzle. When feeding the material to the *rag machine*, it is taken from the side of the pile.

31. Construction and Operation of Rag Machine.—The rag machine, shown in perspective in Fig. 9 and in section in Fig. 10, consists essentially of a rapidly revolving swift, or cylinder, *c*, 36 inches in diameter and about 18 inches long, and set with straight, hardened steel teeth that project about 1 inch above its surface. In operation the rags are placed on the feed-lattice *a*, which carries them to the 2-inch feed-rollers *b*, provided with sharp flutes; these hold the rags while the teeth on the cylinder pulls them into threads or fibres. Any large pieces of rag that may pass between the feed-rollers without being pulled fly upwards to the *beater*, or *bit roller*, *d*, which beats them back on to the feed-lattice, so that they may again pass between the feed-rollers. As small pieces of rag may pass the beater, a plate *e* is arranged over the cylinder to guide such pieces into

the box *f*, from which place they are taken at intervals and again placed on the feed-lattice. The plate *e* may be adjusted as required by means of the thumb screw *e*₁. The light, pulled material remaining on the cylinder is removed and forced out of the machine by means of the fan *g*, which sends a strong blast of air through the outlet funnel *h*.

32. Driving.—The operation of a machine having a cylinder 18 inches long requires from 10 to 15 horsepower. A 9-inch belt conveys the power from the line shaft to a fast pulley on

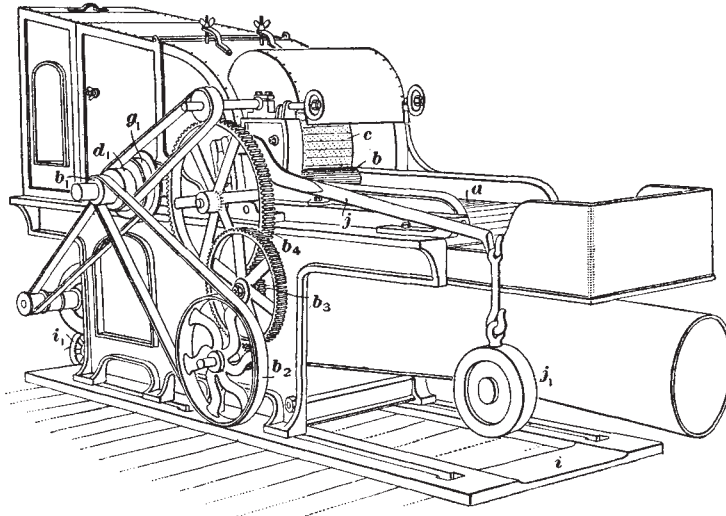

FIG. 9

the cylinder shaft; this pulley may be 12 to 16 inches in diameter, varying according to the speed required. To avoid altering the length of the belt when a change in the speed is required, the whole machine is made to slide on a base *i*, Figs. 9 and 10, by means of a hand wheel *i*₁ operating a screw *i*₂ which engages a stationary nut at *i*₃ and is connected to the machine at its other end. The beater and fan are driven by belts from pulleys *d*₁ and *g*₁ on the cylinder shaft, Fig. 9.

33. The feed-rollers *b*, Fig. 10 (*a*), are driven by the pulleys *b*₁, *b*₂, and a number of gear-wheels, the last one *b*₄ being fastened

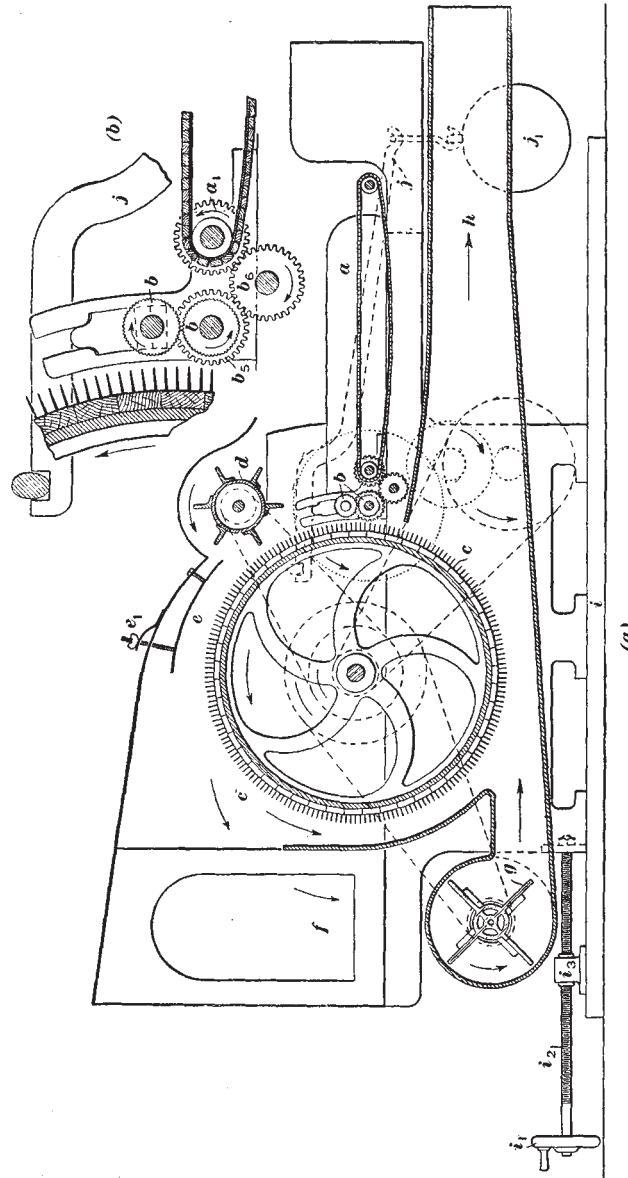

FIG. 10

to the bottom feed-roller shaft. The pinion b_3 is a change wheel by means of which the speed of the feed-rollers may be varied. The feed-lattice, as seen from the detail view, Fig. 10 (*b*), is driven from a wheel b_5 on the bottom feed-roller through carrier wheel b_6 , which gears with the gear-wheel a_1 on the feed-lattice roller. The top feed-roller is driven by friction, the heavy pressure which is put on it causes the flutings on the rollers to serve as teeth of intermeshing gear-wheels. The top roller b is forced against the lower one by a long lever j , which has its fulcrum near the roller, and on its other end carries a weight j_1 . As the leverage is approximately 6 to 1, and the weight about 50 pounds, the pressure on the top roller is about $6 \times 50 \times 2 = 600$ pounds, since the weighting arrangement is duplicated on the other side of the machine.

34. Setting and Production.—The quality of the material produced by the rag machine depends on the setting of the parts and their relative speeds. The shoddy manufacturer, who sells to the cloth manufacturer, will differ in his views as to the desirable properties of the material from those held by the cloth manufacturer, if the latter makes his own shoddy. In order that the pulled material may show to its best advantage, the shoddy manufacturer desires that the character of the best parts of the blend shall be prominently displayed. For instance, in pulling worsted serge or stocking, the worsted nature of the material must be evident, hence the pulled material must show the worsted thread. If such material is pulled to a fibrous state, it appears as if made from woollen goods, and though it is perfectly genuine, it is more easily adulterated and therefore does not inspire confidence. Material in a thready condition, however, requires much more carding to open it and so lessens production. The manufacturer who pulls his own material reduces it to a fibrous state and so increases production with a corresponding reduction of cost.

35. To obtain finely pulled material the cylinder will be run at a fast speed and must have closely set teeth. The feed-rollers will run comparatively slowly and be set rather close to the cylinder. Stockings would be pulled coarse, that is, with threads left

in them, by using a cylinder, which has 20 teeth in each lag, and running at a speed of about 500 revolutions per minute, with the feed-rollers set $\frac{3}{4}$ to 1 inch from the cylinder. The feed-lattice would be travelling at the rate of about 60 inches per minute. If the stockings are to be pulled fine, then a 32- to 36-cylinder will be required, running at a speed of 600 to 700 revolutions per minute ; the feed-lattice will travel at a speed of about 30 inches per minute and be provided with a thicker layer of material. The cylinder teeth are made from hardened steel, but the work performed is so severe that after about 18 weeks' continuous work they become worn down to short stumps. It is therefore customary to have an extra cylinder in reserve.

36. For pulling serges medium fine the cylinder will have from 30 to 45 teeth per lag and be 18 inches long. If mungo is to be finely pulled, the cylinder will have from 45 to 60 teeth per lag. In the latter case flat teeth are used by reason of their greater strength. When pulling milled rags for producing mungo, the cylinder teeth become, after a few hours' running, slightly worn on the front sides ; but if soft material is pulled for producing shoddy, the teeth may run from 1 to $1\frac{1}{2}$ days before showing similar signs of wear. When the teeth show appreciable wear, the cylinder is lifted out and turned end for end, so that the rear sides of the teeth may be used. The production of a rag machine varies considerably according to the class of work and the condition in which the product is desired. The finer pulled material, such as mungo, requires a cylinder speed of about 800 to 900 revolutions per minute, while for shoddy as low a speed as 500 revolutions is used. The approximate production of a machine with a cylinder 18 inches long, when properly managed and delivering the material in good condition, is about $4\frac{1}{2}$ to 6 packs of mungo, $5\frac{1}{2}$ to $6\frac{1}{2}$ packs of medium serges, 6 to 7 packs of fairly coarse woollens, and 7 to 8 packs of stockings, per day of 10 hours.

In judging pulled material the following points must be considered : (a) Cleanliness, or freedom from dirt ; (b) quality or fineness, and evenness of same ; (c) whether the material is new or old ; (d) freedom from cotton ; (e) colour.

MIXING

LAYING OUT MIXTURES

INTRODUCTION

37. Importance of Proper Mixing.—Although the importance of proper methods of *mixing*, or *blending*, the material before subjecting it to the carding process is often underrated, it may be stated with truth that the character of the yarn ultimately produced depends, to a great extent, on the manipulation of the material at this point. Though the term blending is largely used, the term mixing will be adopted in this Paper. **Mixing** is the blending, or amalgamation, of different colours or qualities of wool, or of wool and cotton, wool and shoddy, and may be resorted to for one or more of the following purposes: (*a*) To manufacture a yarn at a given cost by mixing together materials of different values; (*b*) to produce a mixture shade by mixing materials of various colours; (*c*) to produce a yarn as uniform in quality as possible; (*d*) to minimize defects due to previous processes.

38. Sometimes the mixture is simply one of colours; for instance, if it is desired to produce a grey mixture, the result will be obtained by blending wool that has been dyed black with pure white in proportion to the shade of grey desired. Again, it may be found that a certain grade or quality of goods is costing too much. In such a case, if the cost of production is already reduced to a minimum, the only recourse is to reduce the cost of the material entering into the goods. If a high grade of goods is being made, the cost of the material may be reduced by blending a cheaper grade of wool with the finer and more expensive previously used. If a medium grade of goods is being manufactured,

a little shoddy or cotton may be mixed ; while, if the lowest grades of goods possible are being made, various kinds of fibres may be blended together, material possessing any spinning qualities at all being of value.

39. At first thought, it would seem a comparatively simple matter to mix two or more materials together and spin a yarn from the mixture, but when it is considered that the materials to be mixed are often radically different in physical structure and that they should be so mixed as to be indistinguishable one from another, the difficulty will be recognized. The yarn spun from any mixture should also be as even and level as though only one material were used, and if the mixture is one of colour, it should be so perfect that the colours of the original ingredients cannot be distinguished except on close inspection.

40. It matters little how perfect are the colour and the design of a fabric, or how carefully the other processes of manufacture are accomplished, if the mixing of the raw material has been carelessly or imperfectly performed the finished cloth will show more or less imperfections. Sometimes the cloth will be covered with specks, usually of the lighter-coloured material used in the mixture ; such cloth must either be sold for seconds or piece-dyed. A thread composed of poorly mixed materials when examined under a microscope reveals, instead of the perfect amalgamation of the individual fibres of different materials, a mass of the fibres of one material in one part and a mass of the other in another part of the thread. The evenness of the thread itself is liable to imperfections, since it is impossible to spin an even thread from unevenly mixed materials. Especially is this true in a case where the mixture is composed of materials of different spinning properties and of different lengths of staple. In cases like this the roving will not draw well in spinning and the yarn will be liable to contain *twits*. A *twit* is a thin place that looks as though the yarn were partly broken. If the spinner cannot make a first-class yarn out of poorly mixed materials, neither can the weaver make a perfect piece of cloth from an inferior yarn, nor the dyer and finisher produce superior results.

41. Mixing is resorted to, not only for combining colours or qualities of materials, but is also occasionally used in the best mills in lots of one colour and quality, since any mistakes in sorting, washing, dyeing, etc., are by this process equally distributed through the entire batch. The more that wool is mixed and worked over, without injury to its natural qualities, length of staple, and physical structure, the evener will be the yarn and cloth made from it.

PRODUCTION OF DIFFERENT MIXTURES

42. **Laying Out Mixture With Two Materials.**—Whatever may be the materials to be mixed, the same general method is followed in mixing ; for though the process of mixing has been in use for many years, no improvement has been found on the old method, which consists of spreading the materials to be mixed in thin alternate layers on the floor of the mixing room. For a simple example, suppose that a grey mixture composed of 50 per cent. black and 50 per cent. white wool is required ; the method of procedure will be as follows : Equal quantities of black and white wool will be weighed out first, and then, on a clean floor space, a layer of black wool will be spread over as large an area as is convenient, but depending in some measure on the number of pounds of material to be mixed. Each layer will be made about 7 or 8 inches in depth, care being taken to have it spread evenly and of uniform depth. Then a similar layer of white wool will be spread over the first layer of black, being careful to have approximately the same quantity of material in the layer of white as in the layer of black wool. Then another layer of black, then white, and so on until the lot is completed.

43. **Removing Material From Mixture.**—The mixture is now ready to be put through a mixing machine, teaser, or shake-willey as such a machine is usually termed. In taking the material from the pile on the floor, great care should be taken to break it down from the side or end and not from the top ; otherwise, the benefit of laying out the material in successive layers is lost. If the material, however, is taken carefully from the end, a portion of each layer will be fed to the teaser in every armful. It is customary

to oil the material as each layer is spread during the mixing, but this process will be described later. In many instances a

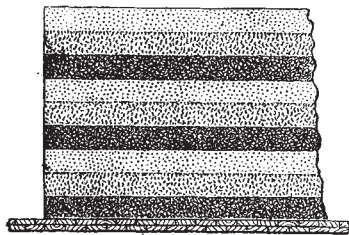

FIG. 11

In the illustration, the dark-shaded divisions represent material or colour No. 1; the medium-shaded divisions, material or colour No. 2; and the light-shaded divisions, material or colour No. 3.

mixture contains more than two materials; in some cases three, four, or even more components enter into it.

Fig. 11 represents the mixing of three colours of the same material, or three materials.

In the illustration, the dark-shaded divisions represent

44. Laying Out Fancy Mixtures.—In making fancy mixtures, it is sometimes possible to devise some advantageous methods of laying out the mixture; for instance, suppose that a fancy mixture composed of 50 per cent. black wool, 25 per cent. white, and 25 per cent. olive is required. If the layers were laid out on the floor in the order and percentages given, to make the individual piles of different-coloured wools come out even, or be used up at the same time, it would be necessary to make the layers of black wool twice as thick as those of either the white or olive wool. This would not distribute the different ingredients so well as if the layers of material were made of the same thickness and distributed in the following order: black, white, black, olive; this process would be repeated until the wool was all used up, and if the layers were of the same thickness they would come out even. This method, of course, would be impossible if there were only two ingredients in the mixture.

45. In laying out a mixture containing different percentages of materials, where it is not possible to divide the material so that each layer shall be of the same thickness, care should be taken to make the layers of each material vary in thickness as near as possible according to the percentage of that material in the total mixture; otherwise, the ingredient of which there is the smallest amount will soon be exhausted and the rest will have

to go on top, thus destroying the evenness of distribution and the uniformity of the mixture.

46. In dealing with mixtures of great diversity of quantity as well as colour and quality of components, it is often customary to prepare a temporary mixture with the small quantity and a part of the larger quantity of material and then finally mix this temporary mixture with the rest of the material. In this manner the small quantity of one ingredient is more evenly distributed through the large amount of the other. For instance, suppose that a mixture composed of 90 per cent. black and 10 per cent. white is required. If these are mixed directly, there is such a small amount of white present that it will be difficult to distribute it evenly, so that if the amount of mixture required is 500 pounds, a temporary mixture of 50 pounds of white and 100 pounds of black, making a mixture of 150 pounds, will be prepared. The temporary 150-pound mixture will then be mixed with 350 pounds of black, making 500 pounds of the final mixture, which will contain only 50 pounds, or 10 per cent., of white wool.

47. In mixtures where several colours are used, it is sometimes the custom to mix the smaller proportioned colours together first and run them through the teaser, and afterwards mix this temporary mixture with the colour that occurs in the greatest proportion. For instance, if a mixture were being made of 40 per cent. black, 20 per cent. brown, 20 per cent. olive, and 20 per cent. slate, the custom would be to first mix the brown, olive, and slate, and afterwards mix this with the black. This would ensure the colours being more evenly distributed.

48. In making a mixture where there is an extremely small amount of one ingredient, such as an Oxford mixture containing 97 per cent. of black and 3 per cent. of white, it is customary to card that material which enters into the mixture only in a small percentage before it is mixed, in order to make it more lofty and enable it to be more uniformly distributed. This is usually accomplished by having an extra carding machine and allowing the material to drop on the floor from the end of this machine. Or, if this is not convenient, it may be run through a machine

termed a *tenter-hook willey*, or *fearnought*, before being mixed. These machines will be fully explained farther on.

49. Care must be taken in making fine mixtures to have all the materials of approximately the same length of fibre, if the best results are to be obtained. If short fibres are mixed with long ones, that is, extremely long in comparison, they do not strengthen the yarn to a great extent, although they make the yarn more bulky. There is also a tendency for the short fibres to bunch up, or form into *neps*, during the carding and the drafting of the roving in spinning and produce twits in the yarn.

50. Passing Mixtures Through Mixing Machines.—In regard to the number of machines that a mixture is passed through, little can be said, as it all depends on the condition in which the material is received from the preceding processes and the materials and colours that are being mixed. If the material is well opened and lofty and the mixture has been carefully made, it will probably not be run through more than two machines. Some materials are more difficult to mix thoroughly than others, and some colours also have a tendency to show up more than others if not thoroughly amalgamated, even if the material is the same. The only way to tell how many machines the mixture needs to be passed through, is to examine it and see if the fibres are well and evenly mixed ; if not, and they occur in separate patches, it is well to run the mixture through another machine. Some mills make a practice of running mixtures through three machines, while others consider two sufficient. Definite rules, however, should never be allowed to regulate the handling of all mixtures.

51. Mixing Wool and Shoddy.—In view of the competition that is now prevalent, many manufacturers deem it wise to mix varying percentages of cheaper material into their goods in order to gain the market against a competitor by underselling him. One of the materials mixed with the wool to cheapen the cost of the raw material is shoddy. In order to make a good mixture with shoddy, a short, fine wool will be found to give the best results in the majority of cases. The reason for this is that the shoddy fibres are always of extremely short length and it is

difficult to mix a material possessing a long fibre with one consisting of short fibres and get good results. In selecting shoddy to mix with wool, the length of the shoddy fibre is one of the main points to be observed ; the longer the fibre the more valuable is the shoddy. Where a mill is buying shoddy, care should be taken that it is not adulterated, as, the fibre being naturally short, it is easy to adulterate it with extremely short and inferior material that can hardly be detected. Shoddy is not often worked alone, as the resulting yarn would be tender and almost impossible to spin, but in mixtures with pure wool the shoddy has its purpose in *feeding* the yarn, or making it more bulky.

52. The percentage of shoddy used depends on the class of goods that a mill is running on. If a good grade of goods is being made, it is not wise to cheapen the mixture too much, and, even if shoddy is used, care should be taken to use a good grade ; on the other hand, if the goods are cheap, often the larger part of the fabric is shoddy with only enough new wool to hold the yarn together. In blending wool and shoddy, it is a good practice first to run the materials through the fearnought separately, but in an oiled state, and then to make a mixture on the floor by spreading the materials over each other in successive layers. The thinner the layers of the different materials and the more of such layers, the better is the mixture.

53. In running a blend through the teaser, it must always be remembered that the success of the mixing depends largely on the manner in which the material is taken from the pile spread out on the floor. The material must always be removed from this pile by taking an armful vertically down from the side or end, and not from the top ; this ensures the complete amalgamation of the several layers. While a little shoddy may be used advantageously in connection with wool, care must be taken not to make the percentage of the cheapening element in the mixture large enough to make the spinning of the yarn so difficult as to involve much extra expense ; otherwise, the adulterated yarn will be found to cost almost as much as a pure woollen yarn, owing to the extra cost of manufacture due to lessened production and excessive waste.

54. Mixing Wool and Mungo.—Mungo is mixed with new wool, as is also **extract**, or the recovered wool fibres of union goods composed of wool and cotton or other vegetable fibres. **Flocks**, or the short, fluffy woollen fibres occurring as the waste from raising and shearing or cutting machines, are also used in connection with raw material for producing mixtures, although they are sometimes added to the cloth during the finishing.

55. Mixing Wool and Noils.—These two materials are often blended. Noils are sometimes used alone for the production of low-grade fabrics, but they do not possess the elasticity nor the same strength and lustrous nature of the original wool, although they make one of the best materials for mixing with wool. Noils should preferably be carbonized before mixing, as they are removed by the comb in connection with burrs, chaff, straws, seeds, and other vegetable matter, the action of the comb being to remove all the impurities in a worsted card sliver as well as the short fibres. Noils and pure raw materials are mixed in the usual manner by being spread in alternate layers and then passed through the mixing machine.

In a mixture of wool and cotton that is to undergo a dyeing process, the cotton fibres will not dye the same shade as the wool. It is therefore necessary, if an all-wool mixture is to be passed through a mixing machine, that the latter, if previously used for a cotton and wool mixture, should be well cleaned to eliminate the cotton fibres.

56. Mixing Wool and Cotton.—The addition of cotton to wool in the manufacture of union fabrics and what are termed *angola* yarns is a common practice. Although the adulteration of woollen goods with cotton is not looked on with favour by many people, indeed is greatly deplored, there can be no doubt but that it is beneficial when used in suitable proportion in connection with low classes of goods manufactured from inferior wool substitutes, since the cotton imparts to the fabric strength and wearing qualities that would otherwise be lacking. When cotton is introduced into a fabric, it may either be in the form of separate threads of pure cotton or the materials may be mixed in the raw state. The reasons for including cotton are : (a) To produce a

cheaper yarn ; (*b*) to make a finer yarn than could otherwise be produced ; (*c*) to limit the shrinkage of such goods as flannels and fine hosiery ; (*d*) to produce what are termed *cross-dyed* effects, since cotton can be dyed one colour and wool another.

57. When cotton is mixed with wool it should first be run through the fearnought, or carding machine, in order that it may be opened out and made fluffy, so that it will amalgamate well with the wool fibre and not form into individual bunches. It must be remembered that shoddy, mungo, extract, flocks, and noils are in reality pure wool, although more or less injured by the operations to which they have been subjected ; but cotton is different in structure and requires different manipulation. The wool must be oiled and teased before the mixture is made ; in no case should any oil be applied to the cotton. It is a decided advantage to allow the oiled wool to stand for a few days before the mixture is formed, so that the oil will be absorbed by the wool before it is mixed with the cotton. This process is termed *mellowing*. The materials should then be laid out in successive layers of cotton and wool and afterwards run through the mixing machines a sufficient number of times to ensure perfect amalgamation.

58. The process of making the so-called *vigogne yarn* is as follows : This yarn is sometimes composed of cotton and wool in about equal proportions, although often only from 3 to 10 per cent. of wool is used. The wool should be of quite fine fibre, in order to mix well with the cotton, and should also be well washed, dried, burred, and oiled. The cotton should be of good length of staple and should be run through the fearnought and a single carding process, which is performed on a woollen card. The wool may also be subjected to a single carding process if it is desired to make the best mixture possible. The mixture is then made, in the usual manner, by making a pile of the materials in alternate layers, taking it down vertically from the end, and subjecting it to the operation of two or three mixing machines. It is, of course, only for fine work that so much trouble is taken as to card the materials. The ordinary method, which gives excellent results, is to oil the wool and tease it, run

the cotton through a fearnought, and then mix the wool and cotton in the right proportions and run the mixture through the mixing machines.

59. Cotton is used in connection with wool for low-class materials, such as cassimeres, tweeds, flannels, etc. The cotton fibre should be as long as possible and the wool as fine as the grade of goods will allow, with a medium length of staple, and should also be sound, strong, and full of life and elasticity. As it is desired to have the goods resemble wool as nearly as possible, care should be taken to regulate the percentage of cotton according to the class of goods to be made, always using as little as possible to get goods out at the proper cost. On dress goods, flannels, and boys' suitings, from 50 to 75 per cent. cotton can be used. The cheapest possible lots of cotton are often selected, but it is better to have some consideration for the character of the wool. Where the wool is not very fine, a coarse, wiry cotton, as rough Peruvian or Brazilian, may be used with good results if the goods are dyed dark shades. American cotton, however, is generally used and is well suited for blending with wool. For mixing with fine wool, sea-island cotton, which has a long staple, is often used. The class of cotton used, however, depends solely on the class of trade. For instance, in the high-class flannel trade a good-class raw cotton would be used; while in the medium-class trade, the cotton used would probably be what is termed *fly*, and strippings from cotton cards. The lowest-class trade would use card-room sweeps, and spinning-room sweeps, which contain hard threads.

60. If a large percentage of white cotton is to be used and the yarn or cloth sold is white, the cotton should have a blue stain put on it in order to destroy the chalky white appearance, which is never seen in pure woollen goods. In making a cotton-and-wool mixture composed of 50 per cent. white and 50 per cent. black, one material should not be of one colour, but preferably half of the wool should be dyed black and the other half left white; the same should be done with cotton and the results will be better than if the mixture were made with black wool and white cotton, or vice versa. When using black cotton in

wool mixtures, the cotton should be dyed a blue black in order to overcome the rusty look of ordinary black cotton, which makes the goods look cheap.

61. In fancy mixtures the dyed cotton should be as fast as possible, especially if there is any white or light-coloured ingredient in the mixture. The reason for this is that, unless the cotton dye is perfectly fast, it will *bleed*, or run, in finishing, staining the light-coloured material. The cotton should for the same reason be fast-dyed in goods that have white or light-coloured yarns in the pattern. In particular mixtures the material is laid out in layers the second time, after being run once through the teaser. In mixing only small proportions of cotton with wool it is not necessary to observe so many details; still, the wool should be oiled separately, care being taken not to let the mixture stand too long and thus allow the cotton to absorb the oil from the wool, and the materials should always be first teased separately.

62. If the mixture is well made, the resulting fabric will be free from specks and the care put into the mixing will be well repaid. The carding machines must be in good condition for working cotton-and-wool mixtures, and the wool used must have good milling properties, owing to the total absence of this characteristic in the cotton. If a large percentage of cotton is used, the cloth will have to be set finer in the loom in order to obtain the desired finished texture, as the more cotton used, the less the cloth can be shrunk in finishing. When cotton and wool are mixed and spun together, the cotton, if of long staple, has a tendency to go to the core of the thread and be entirely covered by the wool, which stays on the outside of the yarn. Ramie or China-grass noils have been used in making woollen yarns. They make a very strong but non-elastic yarn, provided that not more than about 20 per cent. of the material is added to the yarn.

63. Mixing Wool and Silk.—It is sometimes desirable to mix wool and silk waste in the production of fancy mixtures. This is attended with some little difficulty, as the silk is extremely

difficult to card owing to its fluffy nature and its liability to become charged with static electricity if dry and subjected to friction.

When silk is mixed with wool, it is desirable to have the silk the colour of the largest ingredient in the mixture; if, for instance, the mixture is composed of 80 per cent. black and 20 per cent. white, the silk waste should be dyed black in order to make the blend look even. The silk waste should first be carded before any attempt is made to introduce it into a mixture.

64. It is important that both ingredients should be free from grease and gum. In oiling wool-and-silk mixtures, the oil used should be of good quality and free from any acid, the wool being oiled separately as with cotton-and-wool mixtures. No oil should be applied to the silk. If there is quite a large percentage of silk in the mixture, and trouble from electricity or from an excessive amount of flyings is experienced in the carding, it may be necessary to dampen the silk with water before mixing. This can be done by spreading the silk in quite thin layers on the floor and covering it with wet bagging. If the bagging is wet enough and allowed to remain on the silk over night the material will become sufficiently damp. If water is applied directly to the silk, the fibres are liable to mat.

65. **Mixtures of Different Wools.**—The work of making mixtures requires care, judgment, and experience if the result is to be satisfactory both as to quality and cost. At first sight it might appear that cheap materials would of necessity enable a cheap yarn to be produced, but this is not an invariable rule, since the increased amount of waste made and time spent in the production of a badly constituted cheap mixture often results in a comparatively expensive yarn. The following are mixtures that are often made and are arranged in order as to quality: Corresponding qualities of Saxony, Port Philip, Tasmanian, Sydney, and Cape wool; Port Philip lambs' wool with certain qualities of Cape fleece wool; medium-quality short colonial wool with 15 to 20 per cent. cotton; medium-quality short colonial wool with shoddy; colonial cross-bred wool with similar qualities of Cheviot wool; lower qualities of colonial

wool with shoddy ; lower qualities of colonial wool with extract ; short English lustre wool with alpaca or mohair noils ; coarse noils with shoddy.

66. Fancy Effects Due to Mixing.—Sometimes it is desired to produce spots of colour in yarns for such cloths as cap tweeds and Cheviot suitings. The following are two common methods :

1. In the high-class cloth the ground is formed of wool yarn having a long, strong fibre that requires very little carding. The spots of colour are made from botany noils that have been dyed the required shade. Botany noils are always very neppy in character, and carbonizing and dyeing tend to increase this characteristic ; but if it is not sufficient the noils are put in a bag in a wet condition and milled with soap and water until the material becomes one mass of hard knots of fibres. To loosen and prepare the material for mixing with the loose ordinary material, it may be passed through a fearnought as many times as is necessary. After mixing the neps with the ordinary material the mixture is carded, the carding machines being set to give the minimum amount of carding, and the neps pass through in a practically unopened condition.

2. The nepping material used in the low-class cloth will not easily form into neps, since it is often cotton ; therefore, the means adopted for producing the neps is different. One good method is to run those rollers of a carding machine that are termed *doffers* and *workers* in the reverse direction and set them about $\frac{1}{8}$ inch from the cylinder ; they then catch the ends of the fibres, and the cylinder rolls them into neps and drops them underneath the doffer. The material that forms the ground portion of the yarn is usually of low quality and requires much carding ; if the material contained the neps they would be opened out. Special appliances are therefore used to drop the prepared neps between the last pair of a series of rollers, called *workers* and *strippers*, or between the ring doffer and the cylinder, so that they amalgamate and come through unopened with the roving.

67. Summary of Mixing.—In general, when making a mixture, the material should be spread quite thinly over a large area.

As many layers as convenient should be made, and if one material enters into the combination only in a very small proportion, care should be taken to make first a temporary mixture with this ingredient and a part of the one that forms the ground, or bulk, of the mixture. The pile should be broken down vertically from the end and the material run through a sufficient number of machines to ensure perfect mixing.

If a cotton-and-wool or wool-and-silk mixture is being made, the wool should be oiled separately ; otherwise, the cotton and silk will be difficult to mix and card. It is not wise to depend on the materials becoming mixed in the carding machines. They should be mixed first, so as not to make a mixing machine of the first carding machine. The same amount of care should be taken with all-wool mixtures as with wool and cotton, in order to ensure evenness and perfection throughout the operations following.

CALCULATIONS FOR MIXING

68. Use of Calculations.—In mixing materials that vary in cost, it is often necessary to ascertain the cost of the mixture per pound in order that the value of the resultant yarn or fabric may be estimated. Again, it may be necessary to ascertain the percentage of a cheaper material required in a mixture, in order that it may be produced at a given value. Many other conditions also arise in connection with mixing that require accurate calculating in order that the cost of the finished goods or their character may not be altered.

69. Costs of Unoiled Mixtures.—If a mixture is to be composed of several materials that are not oiled, the price per pound of the mixture may be found by the following rule :

Rule.—*To find the cost per pound of a mixture composed of several unoiled materials, multiply the number of pounds of each material by its cost per pound, and divide the sum of the products thus obtained by the total number of pounds in the mixture.*

EXAMPLE.—What is the cost per pound of a mixture composed of 45 pounds of wool at 14d. per pound, 25 pounds of cotton at 7d. per pound, and 10 pounds of shoddy at 4·5d. per pound ?

SOLUTION.—Applying the rule,

$$\begin{array}{r} 45 \times 14 = 630 \text{ d.} \\ 25 \times 7 = 175 \text{ d.} \\ \underline{10 \times 4.5 = 45 \text{ d.}} \\ 80 \text{ lb.} \qquad 850 \text{ d.} \end{array}$$

Since the total weight of the mixture is 80 lb. the cost per pound of the mixture will be

$$850 \div 80 = 10\frac{5}{8} \text{ d. Ans.}$$

70. Costs of Oiled Mixtures.—If a mixture is composed of materials that have been oiled, its cost per pound is found by the following rule :

Rule.—To find the cost per pound of a mixture composed of oiled materials, multiply the number of pounds of each material by its cost per pound and add the cost of oil used, found by multiplying the price of the oil per gallon by the number of gallons ; divide the sum of these products by the total number of pounds in the mixture.

EXAMPLE.—What is the cost per pound of a mixture of oiled wool composed of 1,500 pounds of New Zealand slipe wool at $7\frac{1}{2}$ d. per pound, 1,000 pounds of English wool at $6\frac{1}{2}$ d. per pound, 2,000 pounds of noils at 7d. per pound, 500 pounds of pulled white waste at 6d. per pound, if 1 gallon of oil at 1s. 6d. per gallon is allowed for each 100 pounds of the mixture ?

SOLUTION.—In applying the rule, it is to be noted that it is not customary to add the weight of the oil to the total weight of the mixture. The total weight being 5,000 lb., the amount of oil required is $5,000 \div 100 = 50$ gal., which at 1s. 6d. will cost $50 \times 18 = 900$ d. Adding this amount to the cost of the mixture, the total cost will be $34,750 + 900 = 35,650$ d.

The price per pound is therefore $35,650 \div 5,000 = 7.13$ d. Ans.

71. Proportions of Ingredients.—When a mixture is to be composed of several materials to produce a mixture of a given cost per pound, the relative amounts of the materials are found by the following rule :

Rule.—To find the amounts of the various materials to be combined into a mixture of a given price per pound, arrange the respective costs per pound of the materials in a column and place the desired cost of the mixture at the left. Link these values together in pairs, so that one element of each pair is greater and one less than the

average cost. Find the difference between the average price and each element of a link and write it opposite the other element of the same link. Each of these differences has the same relation to their sum as the quantity of each material has to the mixture.

EXAMPLE.—It is desired to mix enough cotton costing 5d. per pound with wool costing 11d. per pound so that the resultant mixture will have a value of 9d. per pound ; what proportion of each ingredient is necessary ?

SOLUTION.—The values of the material are arranged in a column, as shown, with the desired cost at the left. The difference between 9 and 11 is 2, which is placed opposite the 5 to which the 11 is linked ; there being only the two values 5 and 11, only one link can be made. The difference between 9 and 5 is 4, which is placed opposite the 11 to which the 5 is linked. As the sum of 2 and 4 is 6, it is seen that each 6 lb. of mixture should contain 2 lb. of the cotton and 4 lb. of the wool. Ans.

PROOF.—This example can be proved by applying the rule in Art. 69, as follows : 4 pounds of wool at 11d. per pound will cost 3s. 8d. ; 2 pounds of cotton at 5d. per pound will cost 10d. The total cost of the mixture will be 3s. 8d. + 10d. = 4s. 6d. The cost per pound of the mixture will be 4s. 6d. ÷ 6 = 9d.

72. When the rule in Art. 71 is applied to a case where more than two ingredients enter into the mixture, care must always be taken to link together a higher and a lower value than the desired average.

EXAMPLE.—Suppose that four materials, A at 3d. per pound, B at 5d. per pound, C at 8d. per pound, and D at 10d. per pound are to be mixed ; what proportion of each will be necessary so that the resulting mixture will have a value of 7d. per pound ?

SOLUTION.—The prices of the materials are arranged in a column, as shown. Linking the numbers 5 and 10 by connecting them with a bracket and ascertaining the differences between each of them and the desired cost, 7d., it is found that the difference between 10 and 7 is 3, which is placed opposite 5 ; the difference between 5 and 7 is 2, which is placed opposite 10. The values 3 and 8 are next linked together, then the difference between 3 and 7 is 4, which is placed opposite 8 ; the difference between 8 and 7 is 1, which is placed opposite 3. As the sum of these differences is 10, it will be seen that each 10 lb. of the mixture should contain 1 lb. of A, 3 lb. of B, 4 lb. of C, and 2 lb. of D. Ans.

PROOF.—This example can be proved by applying the rule in Art. 69, as follows : 1 pound of A at 3d. per pound will cost 3d. ; 3 pounds of B at 5d. per pound will cost 1s. 3d. ; 4 pounds of C at 8d. per pound will

$$9 \left\{ \begin{array}{l} 5 \\ 11 \end{array} \right\} \begin{array}{l} 2 \\ 4 \end{array}$$

$$7 \left\{ \begin{array}{l} 3 \\ 5 \\ 8 \\ 10 \end{array} \right\} \begin{array}{l} 1 \\ 3 \\ 4 \\ 2 \end{array}$$

cost 2s. 8d. ; and 2 pounds of D at 10d. per pound will cost 1s. 8d. The total cost of the mixture will be 3d. + 1s. 3d. + 2s. 8d. + 1s. 8d. = 5s. 10d. The cost per pound of the mixture will be 5s. 10d. ÷ 10 = 7d.

73. Referring to the example in Art. 72, it should be noted that by linking different quantities together, taking care to link a higher and a lower value than the required average, the proportions of the different ingredients may be varied and at the same time the correct average cost obtained. To illustrate, the same example may be solved in the following manner :

SOLUTION.—Here the values 3 and 10 and 5 and 8 are linked together, as indicated by the brackets. The difference between 10 and 7 is 3, which is placed opposite 3 ; the difference between 3 and 7 is 4, which is placed opposite 10. The difference between 5 and 7 is 2, which is placed after 8 ; the difference between 8 and 7 is 1, which is placed after 5. From this it will be seen that each 10 lb. of the mixture should contain 3 lb. of A, 1 lb. of B, 2 lb. of C, and 4 lb. of D. Ans.

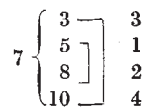

PROOF.—This example can be proved by applying the rule in Art. 69. 3 pounds of A at 3d. per pound will cost 9d. ; 1 pound of B at 5d. per pound will cost 5d. ; 2 pounds of C at 8d. per pound will cost 1s. 4d. ; 4 pounds of D at 10d. per pound will cost 3s. 4d. The total cost of the mixture will be 9d. + 5d. + 1s. 4d. + 3s. 4d. = 5s. 10d. The cost per pound of the mixture will be 5s. 10d. ÷ 10 = 7d.

74. In the examples given, two of the materials cost more and two less than the required cost of the mixture ; sometimes, however, only one of the materials may be more or less than the average cost. In a case like this, all the other values are linked to this one and the differences added together.

EXAMPLE.—Four materials, A at 4d. per pound, B at 5d. per pound, C at 7½d. per pound, and D at 11d. per pound are to be mixed ; in what proportion must each enter into the mixture in order that the average cost shall be 8½d. per pound ?

SOLUTION.—As only one value is greater than the required cost of 8½d., all the smaller values are successively linked to the greater value 11, as shown. The difference between 11 and 8½ is 2½, which is written after each of the smaller values with which 11 is linked. The differences between 8½ and 4, 5, and 7½ are 4½, 3½, and 1, respectively, and they are written after 11, with which they are linked. The

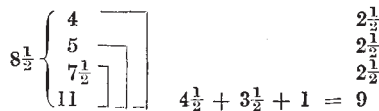

sum of the differences is $16\frac{1}{2}$ lb. ; hence, each lot of $16\frac{1}{2}$ lb. must contain $2\frac{1}{2}$ lb. of each of the materials A, B, C, and 9 lb. of the material D. Ans.

75. In the preceding examples were found the relative proportions of the ingredients in a small portion of the whole mixture. The total amount of each ingredient in the mixture may be found by means of ordinary proportion ; the method to be followed is shown by means of the succeeding example.

EXAMPLE.—By applying one of the preceding rules, it was found that in 23 pounds of a given mixture, consisting of three ingredients A, B, and C, it is necessary to take 6 pounds of A, 6 pounds of B, and 11 pounds of C. If it is necessary to produce 20 packs of the mixture, each pack weighing 240 pounds, how many pounds will be required of each ingredient ?

SOLUTION.—The total weight is $20 \times 240 = 4,800$ lb. ; hence, to find the required weight of the ingredient A the following proportion applies :

$$6 : 23 = x : 4,800, \text{ or } x = \frac{6 \times 4,800}{23} = 1,252.17 \text{ lb.}$$

Of the ingredients A and B 1,252.17 lb. is therefore required. To find the required weight of C, the following proportion is used :

$$11 : 23 = x : 4,800, \text{ or } x = \frac{11 \times 4,800}{23} = 2,295.65 \text{ lb. Ans.}$$

76. In some cases there is a certain amount of material on hand with which it is desirable to mix some other material so as to produce a mixture at a given price per pound. Problems of this kind are solved in the manner explained in Arts. 71 and 75, except that the proportion for finding the total weight of the ingredients is arranged in a different manner, as the combined weight of the ingredients in the mixture is not known. The method used in solving the problem will be seen from the following example :

EXAMPLE.—It is desirable to mix 750 pounds of wool worth 10d. per pound with a quantity of shoddy at $4\frac{1}{2}$ d. per pound in such proportion that the price of the mixture will be 6d. per pound. How many pounds of shoddy will be required ?

SOLUTION.—Applying the rule given in Art. 71, the prices given are linked as shown. It follows that in each $5\frac{1}{2}$ lb. of mixture there will be $1\frac{1}{2}$ lb. of wool ; as there is to be 750 lb. in the complete mixture, the following proportion applies : $5\frac{1}{2} : 1\frac{1}{2} = x : 750$, from which $x =$ the total weight of mixture = 2,750 lb. As the wool weighs 750 lb., the shoddy must weigh $2,750 - 750 = 2,000$ lb. Ans.

$$6 \left\{ \begin{array}{l} 10 \\ 4\frac{1}{2} \end{array} \right\} \frac{1\frac{1}{2}}{4} \frac{1\frac{1}{2}}{5\frac{1}{2}} \text{ lb.}$$

MIXING MACHINES

TEASER

77. Process of Mixing.—After the materials composing a mixture have been carefully spread in layers on the floor of the mixing room, the next operation is to pass the mixture through a machine designed to intermingle the various components in such a manner that a homogeneous mixture is obtained. The general practice is to use two kinds of machines. The first kind, which is the *teaser*, or *shake willey*, breaks up the large matted pieces of wool or other material and effects a rough mixing; at the same time it exercises a cleaning action. After leaving this machine the material is again spread in layers and in some cases oil is added; it is then fed to the second kind of machine, which is termed the *fearnought*, or *tenterhook willey*; the material received from this machine in a finely divided state is packed ready for the carding machines.

78. Function of Teaser.—The *teaser* is used for cleaning, dusting, and opening wool prior to washing, and also as an opening and mixing machine. A good type of this machine is that known as the *Sykes*, which is described in the section on *Wool Washing*. As an opening and mixing machine it is the first one through which the material is passed after it has been spread out in layers. The wool delivered by the *teaser* must be deposited in a position as near as possible to the *fearnought*, so as to avoid unnecessary labour in carrying the material. One *teaser* should supply sufficient material for 10 sets of carding machines.

FEARNOUGHT

79. Principle of Action.—The *fearnought* is used for the purpose of continuing the operations of the *teaser*, so that when the material leaves the *fearnought* it may be sufficiently opened and divided to allow it to be fed to the carding machines without doing them any injury. The *fearnought* is entirely different

from the teaser, both in principle and construction, as it opens the material by means of a large rotating cylinder fitted with *cocksspur*, or *tenterhook*, teeth, which work in conjunction with similar teeth placed in smaller rollers, known as *workers*, over the large cylinder. The combined action of the cylinder and the workers is that of separating all bunches of wool and intermixing the fibres thoroughly.

80. **Construction.**—A perspective view of a fearnought is shown in Fig. 12, the cover over one half of the machine being

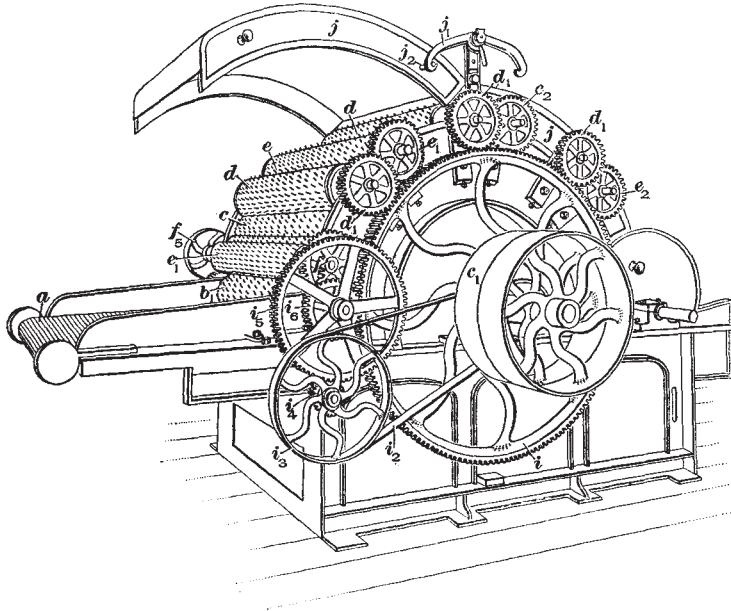
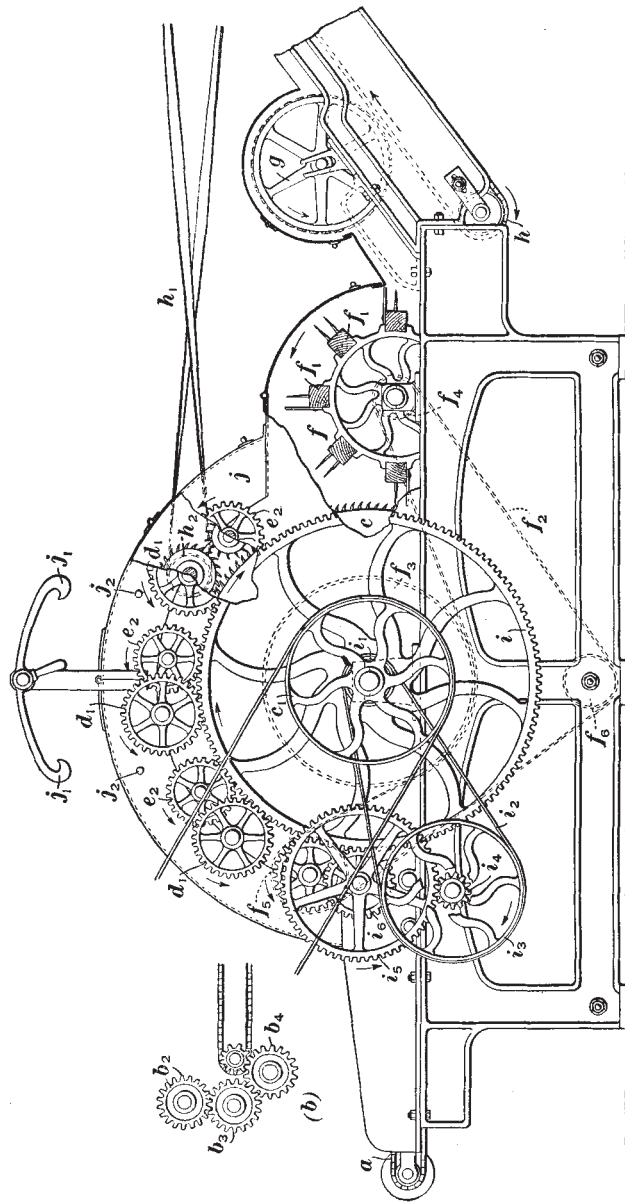

FIG. 12

lifted to show the arrangement of the rollers. Fig. 13 (*a*) is a side elevation of the machine, partly in section, view (*b*) being a detail view of the driving mechanism for the feed-rollers and lattice. Fig. 14 is a detail sectional view of the feed-rollers, cylinder, and a worker with its stripper. While wood is used to a larger extent in the construction of a fearnought than in that of a teaser, this is not objectionable, since the slower speeds of the several parts render them less liable to cause fire than the



(a)
FIG. 13

rapidly rotating cylinder of a teaser. The main cylinder *c*, workers *d*, strippers *e*, and feed-rollers *b*, *b*₁ are of wood fitted with cockspur teeth, forged from steel rods and firmly driven into the wood. The machine is usually constructed with three workers operating in conjunction with three strippers. At the rear of the machine is a beater, or fan doffer *f*, which removes the material from the cylinder and throws it out of the machine.

81. Operation.—In operation the material is spread evenly on the travelling feed-lattice *a*, Fig. 14, and is taken by the feed-rollers *b*, *b*₁, which are covered with cockspur teeth. These rollers

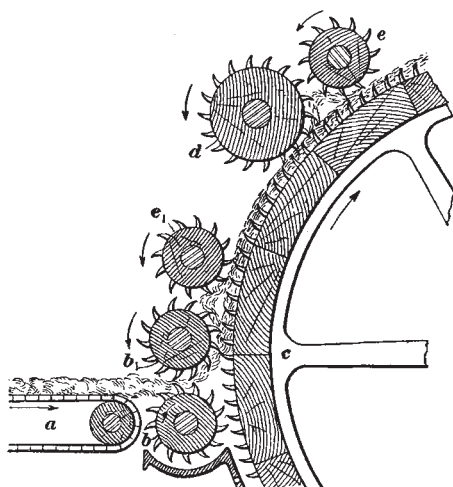

FIG. 14

hold the material firmly, since their teeth point in a direction opposite to that in which it is pulled by the swiftly revolving cylinder *c*, which tears the material over the teeth on the feed-rollers and so performs an opening action. Any material left on the feed-roller *b*₁ is stripped from it by the stripper *e*₁, which returns the material to the cylinder.

As the cylinder carries

the material forwards it is caught by the interacting and slowly retiring teeth on the worker *d*, which is about 6 inches in diameter. Some of the material is retained by the worker, and the remainder is carried forwards by the cylinder; while this division of the material takes place, it is subjected to another opening action. On the rollers the teeth are arranged in circumferential rows, in such a manner that the teeth in one row are opposite the spaces in the adjoining row; when so arranged they are said to be *staggered*. As the rows of teeth on the workers are set so that they come opposite the spaces between those on the cylinder,

the teeth on the workers can be set slightly into those of the cylinder, by this means increasing the efficiency of the machine.

82. The material retained by each of the workers is stripped by a stripper e , Fig. 14, which is about 4 inches in diameter and revolves with its points against the back of the teeth on the worker; the stripper returns the material to the cylinder. As the material passes through each successive worker it is more and more opened out, and when it finally leaves the last worker it is carried forwards by the cylinder to the fan doffer f , Fig. 13, which blows it out of the machine or against the cage g . The fan doffer is 20 inches in diameter and has fixed on its circumference eight bars f_1 , each alternate one of which is fitted with two rows of spikes, while the intermediate bars have one row of spikes and are faced with a strip of flat, stiff leather, having a serrated edge. The doffer is set so that its spikes project into and beyond the ends of those on the cylinder.

83. When the material is ejected from the machine, Fig. 13 (a), in the ordinary way it is deposited in a pile at a distance of some yards from the machine in an open and lofty condition. When working mixtures that contain a certain proportion of very light material, such as cotton, and the heavier material, mungo, there is a tendency for the light material to be blown toward the side of the pile, so that instead of mixing satisfactorily the components have an inclination to separate. By arranging the machine to blow against a wall or specially fixed boards, this tendency is to a certain extent obviated. A more efficient method is to use a delivery lattice and cage, or *running-off apparatus*, as it is termed, which consists of a long lattice h placed at the delivery end of the machine, on which rests a cage g . The material is blown on to the under side of the cage, and as the latter turns downwards a lap is formed on the lattice which can be delivered into sheets and transferred to the carding machines.

84. **Driving.**—A belt from the line shaft to the fast pulley c_1 , Figs. 12 and 13 (a), on the shaft of the main cylinder drives it at a speed of about 150 revolutions per minute. The 6-inch pulley f_4 on the doffer-fan shaft is driven by the belt f_2 from a

30-inch pulley f_3 on the rear end of the cylinder shaft ; carrier pulleys f_5 and f_6 are conveniently placed to give a satisfactory drive. The remaining rollers are all driven from a large toothed wheel i , which revolves loosely on the cylinder shaft. It receives its motion from the pulley i_1 on the cylinder shaft, which by means of a belt i_2 drives the pulley i_3 . The latter is compounded with a pinion i_4 that drives a wheel i_5 fixed on the top feed-roller shaft ; on the same shaft is a wheel i_6 that drives the wheel i . The latter is broad enough to drive both the workers and strippers by means of wheels placed behind each other, as shown at d_1 and e_2 , where d_1 is fixed on a worker shaft and e_2 on a stripper shaft. Each worker and stripper is driven in a similar manner, and the speed of the workers is about 25 revolutions per minute, while that of the strippers is about 30.

85. The bottom feed-roller is driven from the top by equal-sized gear-wheels b_2 and b_3 , Fig. 13 (*b*), situated on the rear side of the machine ; the feed-lattice receives its motion through the carrier wheel b_4 from the bottom feed-roller. The upper end of the delivery lattice h , which is not shown in Fig. 13 (*a*), is driven by the crossed belt h_1 from a pulley h_2 placed on one of the worker shafts, which drives a pulley fixed on the end of the top roller of the lattice. The cage is driven by frictional contact with the delivery lattice, and as it revolves in vertical slots it rises and falls in accordance with the thickness of the material. Over the machine is placed a cover j which is in two parts, each part being hinged at the centre of the machine, so that it may be raised when the machine requires cleaning. The raised part is supported by hooks j_1 arranged to fit pegs j_2 fixed to the cover, as shown in Fig. 12. An alternative method of raising and supporting the cover is by an arrangement of wheels, worm, and chain.

86. **Production.**—A fearnought with a cylinder 36 inches in diameter should make about 200 revolutions per minute ; one having a cylinder 48 inches in diameter should make 150 revolutions per minute. Its capacity varies, according to its size, from 800 to 1,500 pounds per hour. The machine is built in three widths, 36-inch, 42-inch, and 48-inch, having cylinders 36 inches, 42 inches, and 48 inches in diameter, respectively.

WOOL OILS AND OILING

WOOL OILS

CLASSIFICATION AND TESTING OF OILS

INTRODUCTION

1. **Object of Oiling Wool.**—Owing to the removal of the natural, preservative, greasy matter, or yolk, by the scouring, it is necessary to lubricate the fibres of wool with oil before carding and spinning, in order to restore to a certain extent the natural suppleness of the fibre, and to facilitate, as much as possible, the motion of the fibres in sliding over each other during the subsequent operations. The oil will also help to protect the serrations of the fibres from injury, as the serrations of contiguous fibres are less liable to catch in one another. At the same time, oiled wool may be worked with the least waste possible in the carding and may be spun into the finest yarn possible consistent with the quality of the wool. Also, the natural elasticity and softness of the fibre are uninjured if the wool is lubricated and if the oil used is suitable for applying to wool. The oiling of wool before carding and spinning, therefore, is an important process and should be carefully done, not only with regard to the kind of oil used, but also with regard to the quantity used and method of application. Imperfect oiling results in gummed-up machinery, uneven work, and also in the destruction to a greater or less extent of the elasticity of the resultant yarn.

2. Choice of Oil.—Especial care should be taken with the wool for cloth that is to be milled or dyed; the oil used for such material should be pure and one that easily saponifies, thus aiding in the fulling and scouring of the cloth. It should also be free from fatty and resinous acids, as the latter are very difficult to remove during the scouring process, the wool becoming sticky and possessing an unpleasant smell. Impure oil or oil that will not saponify easily will make the dyeing streaky and uneven. If oil is not applied in suitable proportions to wool that, when made into cloth, must be fulled, there is danger of impairing the felting properties of the fibre by injuring its serrations. The oiling of wool also lessens the amount of waste made while the material passes through the subsequent operations.

3. Another very important consideration in the selection of a suitable oil for the oiling of wool is the length of time that may elapse between the oiling process and the washing or scouring out of the oil from the yarn or cloth. If the yarn is to be manufactured into cloth and the cloth finished immediately after the spinning of the yarn, then a more inferior oil may be used as compared with that which it would be necessary to use if the material were to be stocked or stored either in the form of yarn, cloth, or any intermediate process in which the material is to be stored for a time in an oily condition. The importance of this consideration is due to the fact that all oils oxidize to a greater or less degree on exposure to air, and especially is this the case when the oil is spread out in a very thin layer as is the case with oiled wool. Some oils are of course worse than others in this respect, and in all cases where oiled materials have to be stored, care must be exercised in the selection of a suitable oil. When oil oxidizes by the action of the air, a resinous, gummy matter is formed which is very difficult to remove in the operation of scouring, which process usually precedes that of dyeing.

4. Importance of Using Good Oil.—The choice of a suitable oil is of much greater importance in the worsted trade than in the woollen, for in the latter trade it is the general custom to take the material while in its raw state and let it pass from one process to another without interruption until it appears in its

final form as finished cloth. An exception to this is the fancy-mixture trade, where a large stock of yarn may be kept for some time before it is finally manufactured into cloth. In the worsted trade, however, the various processes have been much specialized and become separate divisions of the trade; in fact, they are often carried on in three separate and independent mills. The three processes, here referred to, are combing, spinning, and weaving. *Combing* is the process by which all short fibres and all impurities are removed, and by which the fibres are straightened and arranged so as to form what is known as a *top*. *Spinning* is the process by which the combed fibres are formed into a yarn or thread of suitable fineness, and in the *weaving* process the threads are arranged so as to form a cloth. It may happen that the oiled wool may remain in stock, either in the form of tops, yarn, or cloth, for a period of 6 months, or more, before it is submitted to the dyeing and finishing processes. It is evident that during this extended period an unsuitable oil would be gradually oxidizing and thus be in a condition that would make it difficult to scour it out.

5. Properties of a Suitable Oil.—The oil used for lubricating the wool should be fluid, in order that it may spread easily over the wool fibres and thus neutralize to some extent the injury that may be done to the fibres by the use of alkalies in the scouring process. It should not have any tendency to turn rancid. The oil should have a high *flashing point*, that is, it should require a high temperature to make the oil give off vapour in sufficient quantity to ignite momentarily on the approach of a flame. This property is of importance, since the fire-insurance premium is lower when an oil of a high flashing point is used. Oils used on wools should not be readily oxidized by the atmosphere in order that they may be less liable to *spontaneous combustion*; that is, the oxidization of the oil should not be so rapid as to develop in the interior of the stored material a heat sufficiently high to ignite it. The oils used for good wools will not oxidize rapidly enough to cause spontaneous combustion, but this may be the case with the oils used for low classes of mungo, and lubricating oils contained in oily rags and waste.

VARIOUS OILS AND THEIR EMULSIONS

6. **Olive Oil.**—Although universally acknowledged to be the most suitable for the wool fibre, **olive oil** is only used on the finer and more expensive grades of material, owing solely to its cost. The olives, which grow in warm countries, chiefly in California and in Southern Europe, are collected when ripe, and ground into a pasty mass and pressed. The oil obtained from the first pressing is called *virgin oil*, and is colourless; it is principally used for table purposes. The material, however, is not exhausted by the first pressing, but is treated with hot water and further pressed. The oil obtained by the second pressing is of a fine yellow colour and is the olive oil commonly used for lubricating wool before carding and spinning. By a third pressing of the ground olives an inferior oil is obtained which is used in making soap. The specific gravity of hot-pressed olive oil is about .92. The best olive oil for wool is that known as *Gallipoli*, but many other olive oils are used, notably those from Malaga and Seville, the only precaution necessary being to obtain an oil that is free from impurities. Olive oil is often adulterated with cotton-seed oil, and the difference between the pure and impure article is difficult to detect, except by an expert.

For the finer grades of woollen goods olive oil is often used, since it enables the material to be carded with the least waste and spun to the finest counts. Olive oil softens the material and preserves the natural serrations of the fibre from injury during the carding process, and even after lying in an oiled state for a long time, the fibre will not become hard and stiff nor the oil rancid or stale, provided that the oil used is pure.

7. **Olive-Oil Emulsion.**—The oils used in the woollen trade are usually applied in the form of an emulsion; in the worsted trade this is not always the case. An emulsion is merely a mechanical mixture of oil and water in which the oil exists in a state of the finest division, in which form it is well absorbed by the wool fibre. In order to make this emulsion, it is necessary to add some substance, usually termed the *emulsifier*, that will enable the oil and water to unite, or, to use a common expression,

cut the oil. There are three substances used for this purpose : ammonia, a solution of sodium carbonate, or soda ash, and borax. The first is preferable on account of its volatile nature, but the other two are also quite extensively used.

The oil may be mixed with hot water to which the emulsifier has been added, the mixture being of a quantity sufficient for the entire lot of wool. When using olive oil for the woollen trade a good proportion is about 13 per cent. of oil to the total weight of wool ; for the worsted trade about 3 per cent. of oil is the usual proportion. As a rule, dyed wools require more oil than white wools, especially those of dark shades.

8. In making emulsions the emulsifier is first added to the hot water, and then the oil is gradually added while the solution is stirred ; the stirring being continued until a milky solution is formed. In some cases the required quantity of oil is ascertained by dipping the fingers into this solution and rubbing them together. This method, however, is rather uncertain and it is preferable that the ingredients of the emulsion should be made up in definite quantities. An emulsion of olive oil for fine wools that has been found to give excellent results is made as follows : To 10 quarts of hot water is added 1 pint of ammonia, and to this is added from 4 to 6 quarts of pure olive oil, the quantity of oil varying according to the class of material. This quantity of emulsion will be sufficient for lubricating 400 pounds of wool. For fine wools, and in cases where the yarn is going to lie for a considerable time before being woven, it is always well to use olive oil, as this will keep better in the yarn than any of the cheaper oils, being less liable to grow rancid or gummy.

9. **Lard Oil.**—A very common lubricant used in connection with wool, especially in America, is **lard oil**, which is applied in varying proportions according to the condition of the wool that is being worked ; the specific gravity of this oil is about .93. If the material is very dry or harsh, more oil is required than if the scouring and drying had been properly performed and the wool were soft and contained just enough natural lubricating matter. When of good quality, lard oil is all that can be desired for an

ordinary quality of wool. While not so desirable as olive oil for the finest classes of wools, it meets all the requirements of a good lubricating agent for medium wool without being so expensive as olive oil. In regard to the quantity of the lard oil to be used, it may be stated that it varies according to the material in hand. For wool well scoured and dried, about 5 quarts of oil and 5 quarts of water are used to 200 pounds. This may be reduced to 4 quarts of oil if the wool is quite moist and soft, or increased to 6 quarts if the material is harsh and brittle.

10. Lard-Oil Emulsion.— In making the emulsion, about 1 ounce of borax or 1 gill of ammonia is added to the boiling water. Ammonia is to be preferred on account of its being volatile and not remaining on the wool. To this solution the oil should be added slowly, with constant stirring, until a milky emulsion free from bubbles is formed.

Another recipe for a lard-oil emulsion is as follows: Best lard oil, 4 gallons; water, 5 gallons; borax, 4 ounces. The borax is dissolved in a little warm water and the solution added to boiling water; while the latter is constantly stirred the oil is gradually added. After a few minutes' boiling the emulsion is ready for use.

For ordinary material 10 to 12 per cent. by weight of this solution will be found to be about right, but it must be remembered that no hard and fast rule regarding the amount of lubricating matter to be used on wool can be given. Much depends on the natural condition of the wool, and on its condition after scouring and drying, as these processes may injure the wool so that it will require much more oil than would otherwise be necessary.

11. Oleine.— Another substance that is used very extensively in British practice for lubricating wool is known as *oleine*. It occurs as a by-product in the manufacture of stearine candles, and when free from impurities is an excellent substance for the purpose. When pure it may be easily *saponified*; that is, it will unite with alkali to form a soap, and because of this property it requires only a weak alkali to remove it entirely from the wool. In the process of making stearine candles, stearine and oleic acid are produced, the stearine being afterwards freed from the oleic acid by means of sulphuric acid. Oleine is a product obtained

from the oleic acid, but the sulphuric acid that has been used during the process should be removed, as, if present, it acts injuriously on both the wool fibres and the *card clothing*, that is, the covering on the rollers of a carding machine which consists of a foundation of layers of cloth or sheets of leather into which wire teeth are set.

12. Oleine Emulsions.—Oleine, when employed for lubricating wool, is used in varying proportions according to the material in hand, a good proportion being 4 parts of oleine, free from acid, to 6 parts of water. A little ammonia or borax is added to aid the oil and water in uniting; of this emulsion a quantity of from 15 to 20 per cent. of the weight of the wool is used. If the wool is dyed dark colours, or heavily weighted with any dye stuffs, it is a good plan to use less water and more oil.

Another good emulsion may be made with 10 per cent. oleine and 15 per cent. water of the weight of the material to be oiled. The water should be hot and the borax or ammonia added to it, in order that the oil and water may unite. For wools that are dyed dark colours and heavily weighted with dye stuffs 10 per cent. of water will be sufficient.

13. Cotton-Seed Oil.—Cotton-seed oil is extracted from the cotton seed and is very often used to adulterate olive oil, as its presence is difficult to detect. It is not a good material for oiling wool that has to be stocked for a considerable time, owing to the fairly rapid rate at which it oxidizes; great care should therefore be exercised in obtaining olive oil free from this adulterant. Where the material is to be spun, manufactured into cloth, and prepared for immediate use, cotton-seed oil is quite good, as it is fairly saponifiable and therefore comparatively easily washed out.

14. Black Oil and Brown Cloth Oil.—Black oil, or black cloth oil, and brown cloth oil are the oils obtained by the extraction of grease from the waste washing liquor used in the scouring process. The cake or fatty matter, that rises to the surface of the water in the tanks in the *magma* or *Seak* process of grease extraction, is filtered off and put into cloths termed puddings, which are pressed in hot presses. This process of pressing squeezes out the grease

or fats, the result being the black oil of commerce ; the oil contains not only the wool fats, but also the fats or oils that formed part of the soap used for washing. The black oil is largely used for oiling rags previous to *pulling* them, that is, separating their fibres in the machine known as a *rag machine, grinder, or devil*. Black oil is also used for oiling very low mungo materials, its great advantage being its cheapness, but this kind of oil will not serve for light-coloured cloths. It should be noted that a considerable quantity of this kind of oil is required before the fibres are properly oiled. Brown cloth oil is distilled black oil, and is largely used for oiling materials that have to be manufactured into cloths for the medium-class woollen trade ; it is a fairly good oil for the purpose and at the same time is much cheaper than pure oil.

15. Mineral Oils.—Mineral oils are sometimes used for oiling wools and are preferred by some manufacturers, but they are more difficult to remove from the yarn or cloth by scouring, as they do not easily emulsify ; such oils should therefore be used with great caution. In the presence of some saponifiable oil, such as lard oil or olive oil, mineral oil appears to emulsify more easily, and for this reason is often used mixed with lard oil, as it is then easily scoured from the cloth or yarn.

There are a large number of manufactured oils and various preparations which contain mineral oils, besides many so-called emulsion oils, which consist of oil or oleine held in suspension by a soap solution. All such preparations should be properly analyzed before being bought in quantities, as their action on the material may not be beneficial.

TESTING OF OILS

16. Effect of Acid in Oil.—Oleine is sometimes sold under the name of *elaine oil*, both oils having the same composition and both being liable to contain sulphuric acid ; in fact, they are rarely free from acid, the commercial oil containing usually at least .5 per cent. of acid and sometimes a great deal more than this. If acid is present in any great quantity it will attack the card clothing during the carding of the material, and, if the oil is regularly used, will in time destroy the wire.

17. Tests for Detecting Acid.—A good test for the presence of acid in oil is to place a drop of the suspected oil on blue litmus paper; if the paper is immediately coloured red, acid is present. This test, however, does not give any idea of the amount of acid present, since the least amount will turn the litmus paper red. A better way to test the acid in oleine is by means of a hydrometer. The specific gravity of pure oleine is about $\cdot 91$, but if it contains acid, the oil is heavier in proportion to the amount that it contains.

One of the most delicate tests by which to ascertain the presence of an acid is that in which *phenol-phthalein* is used, a substance that is very sensitive to small quantities of an acid or an alkali. The test may be carried out in the following manner: A quantity of the oil equal to 5 grammes is poured into a glass-stoppered flask; to this is added 100 cubic centimetres of warm alcohol containing a few drops of phenol-phthalein, after which the mixture is well shaken. Measured quantities of a standard alkaline solution, consisting of 20 grammes of caustic soda dissolved in 1 litre of water, are now added to the alcohol solution, the flask being shaken thoroughly after each addition of alkali. These additions of the alkali solution are continued until a reddish colour is produced in the alcohol solution, and which does not disappear after the flask has been shaken.

18. The principle on which the test, explained in Art. **17**, is based is the fact that phenol-phthalein in solution assumes a red colour in the presence of a small quantity of an alkali, but remains colourless as long as a minute quantity of an acid is present. Consequently, when the alcohol solution assumes a reddish colour, it indicates that the solution is no longer acid, but slightly alkaline. If the number of cubic centimetres of alkaline solution added is known, and also the nature of the acid, it is possible to ascertain the amount of acid present. The amount of alkaline solution required to neutralize the alcohol solution varies with the kind of acids found. For instance, 1 cubic centimetre of the alkaline solution will neutralize $\cdot 025$ gramme of sulphuric acid, $\cdot 128$ gramme of palmitic acid, $\cdot 142$ gramme of stearic acid, and $\cdot 141$ gramme of oleic acid, respectively. For instance, if a

sample of oleic oil is tested for acid and in the above test it were necessary to add 6 cubic centimetres of alkaline solution before the reddish colour appeared, then there is in the 5 grammes of oil, used for the test, a quantity of acid present equal to $6 \times .141 = .846$ gramme.

19. General Test, and Test for Cotton-Seed Oil.—Another test for a good oil for wool is as follows: Take 2 parts of a solution of sodium carbonate 3° Beaumé and add to it 3 parts of oil. If, on stirring, a milky solution free from bubbles is formed, without oily drops on the surface, it is an indication of good saponifying qualities.

A good test for ascertaining the presence of cotton-seed oil in olive oil is to take 5 cubic centimetres of the oil to be tested and add an equal quantity of nitric acid of 1.37 specific gravity. The mixture is shaken well together, and then left for 24 hours. If there is present even a small percentage of cotton-seed oil, there will be a more or less brown coloration.

20. Oxidization Test.—A ready method of testing for the tendency to oxidization in an oil is to pour a thin coating of it on a piece of glass and keep it exposed to the air for some time, but in such a position that it will be free from dirt and dust. Tests must be made at frequent intervals to ascertain if it has begun to get sticky. By comparison with an oil of known quality, it is possible to gauge the quality of the sample tested.

21. Testing for Quantity of Oil.—It is very often necessary to find out, not only what quality of oil has been used in oiling the material, but also the quantity and the constituents of the oil, and this requires a somewhat elaborate apparatus. The tests are usually only carried out in connection with the Official Conditioning Houses or similar testing institutions. It is possible, however, to carry out tests in a mill, to obtain the percentage of oil present in any oiled wool, blend, top, or yarn, provided that the mill is equipped with a delicate balance.

The usual method of making such a test is to weigh very accurately a certain small quantity of the material, as, for instance, 2, 4, or up to 16 ounces, and then place it in an ordinary conditioning oven where it remains until entirely dry. On again

weighing the sample the loss in weight will indicate the amount of moisture contained in it.

22. The sample is now carefully washed in soft water by means of a good soap; after thorough rinsing, during which care must be taken that the sample remains intact, the sample is dried to some extent and then again transferred to the conditioning oven, where it is made absolutely dry. It is then weighed again; its additional loss in weight represents now the weight of the grease or oil removed. But it will not be correct to estimate the percentage of oil with regard to the weight of the dry sample, as the latter is supposed to contain a standard percentage of moisture, called *regain*. The standard regain is a certain quantity of moisture added to the absolutely dry material, in order that its percentage of moisture may be such as to make it acceptable to the buyer as well as the seller. The following are the standard regains officially adopted for wool materials: Wool, 16 per cent.; tops, oil-combed, 19 per cent.; tops, dry-combed, $18\frac{1}{4}$ per cent.; yarns, $18\frac{1}{4}$ per cent. The required percentage of moisture must therefore be added to the weight of the dry sample when the percentage of oil is to be calculated. This method of testing, though not accurate, is near enough for practical purposes.

23. **Oil Test With Ether.**—Another method of testing is to use ether as the agent for removing the oil; that is, the wool or other material is washed in ether instead of with soap and water, as in the emulsion or soap method. The procedure is identical with that given in regard to the soap or emulsion method, except that it is not necessary to rinse the material after washing it in the ether. As the ether is very inflammable, great care must be taken to keep the ether vapour away from any exposed flame. Some firms object to this method of testing, because it always shows a greater proportion of oil than the emulsion test, generally averaging about $\frac{1}{2}$ per cent. more. This is undoubtedly caused by the fact that it removes a certain amount of the natural fat left in the fibre after the washing. If this difference of $\frac{1}{2}$ per cent. is allowed for, there is no doubt that this is an accurate method of testing. There is at present no official standard test

for oil, nor is there any standard allowance for oil corresponding to that for moisture.

24. Soxhlet Test for Oil.— If it is necessary to ascertain

accurately both the quantity and the quality of the oily substances contained in a sample of wool, it is preferably done by means of the Soxhlet apparatus, shown in Fig. 1. By its means the sample of wool is repeatedly saturated with pure ether, which will dissolve all fatty and oily matters; subsequently the oil or fat is recovered from the ether and subjected to the necessary tests. The apparatus consists of a flask *a*, a reservoir *b*, and a condenser *c*. The flask *a* is carefully dried, cleaned, and weighed, and then connected to the reservoir *b* by inserting the tube *b*₁ into the cork of the flask, as shown. In the reservoir *b*, which is 12 inches long and 3 inches in diameter, is inserted the sample of wool to be tested, after it has been carefully weighed. The reservoir is closed at the lower end at *b*₂; its upper end is closed by a cork through which projects the lower end of the condenser *c*. This condenser consists of an interior tube *c*₁ surrounded by another tube *c*₂ through which cold water is constantly circulating, entering at *c*₃ and leaving at *c*₄.

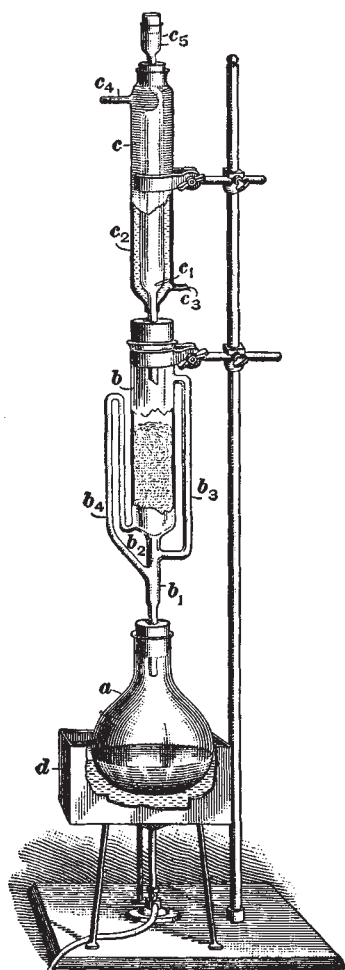

FIG. 1

25. The apparatus is set in operation by pouring a quantity of ether through the funnel *c*₅ of the condenser. The ether runs

down the tube c_1 over the sample in the reservoir b , sufficient ether being poured through the funnel to raise the level of the ether above the upper bend of the siphon b_4 . The latter begins, therefore, to act and draws the ether from the bottom of the reservoir b , discharging it into b_1 , whence it flows into the flask. The ether carries with it a certain amount of fat and oil dissolved from the wool.

26. The flask a is now immersed in the water bath d , heated by a gas flame; as the ether becomes warm it vaporizes, the vaporization beginning at about 60° F. The vapour passes from the flask a , through the tubes b_1, b_3 , into the upper part of the reservoir b and into the inner tube c_1 of the condenser c , where the

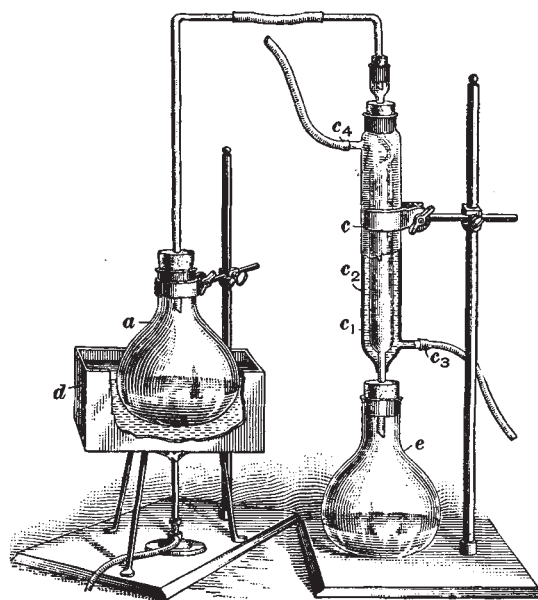

FIG. 2

vapour condenses. The liquid ether runs down along the sides of the tube c_1 and drops gradually down on the sample in b , where it accumulates, thoroughly saturating it. Eventually the ether reaches a height sufficient to set the siphon in action, which again transfers the ether to the flask with an additional quantity

of the dissolved fat or oil. The processes of evaporation and condensation are repeated and continued until all the oil has been extracted from the sample and transferred to the flask *a*, where it remains as a non-volatile substance.

27. The test illustrated by means of Fig. 1 is now continued in the manner shown in Fig. 2. Here the reservoir *b*, Fig. 1, has been removed from the flask *a*, the latter being connected directly to the condenser *c*. The flask *a* is immersed in a water bath *d*, as before, and all the ether vaporized, the vapours passing into the condenser *c*, whence the liquefied ether drops into the flask *e*. In the flask *a* there remains only the fat or the oil extracted from the sample. On carefully weighing the flask with its contents, and deducting the weight of the empty flask, the weight of the substance extracted is found. It is then possible to calculate the percentage of oil contained in the sample. The contents of the flask can also be subjected to the usual rough tests or to an accurate chemical analysis.

28. **Summary as to the Qualities of a Good Oil.**—It is of the greatest importance that a suitable oil should be selected for oiling wool. The use of cheap oil is false economy, owing to the increased amount of waste in the carding and spinning and the decreased production and quality. The price of the oil used is comparatively cheap as compared with the cost of the wool, and the amount used should not be stinted any more than the quality.

The following characteristics should be possessed by an oil that is suitable for lubricating wool: It should be readily emulsified by an alkali, in order to be easily removed from the yarn or cloth by scouring; it must not be oxidized by exposure to the air, nor become rancid; and it should be free from mineral and other acids that might injure the fibres or the machinery. An oil for oiling wool should also be devoid of colour and smell, as far as possible, and must not stain the wool. It should be fluid, so that it may readily be converted into the condition of fine drops or spray, and it should be free from all resinous or other substances that are likely to clog the wool or the machinery and thus interfere with the processes of manufacture.

METHODS OF APPLYING OIL

HAND AND AUTOMATIC OILING

OILING BY HAND

29. Stage at Which Oil is Applied.—The methods of applying oil to wool vary considerably, both as regards the apparatus used and the position of the process relative to others to which the wool is subjected in the woollen and worsted trades. In the former, oiling takes place soon after washing and drying, generally during the operation of blending. In the worsted trade it is customary to submit the wool to the operation of carding while it is in a damp state and then to *backwash* it.

30. Oiling After Backwashing.—The process of *backwashing* is performed for the purpose of removing the dirt that is left in the wool after the scouring process, and other dirt and dust collected by the material while in the carding machine. The back washing takes place in two bowls, one of which contains a hot soap solution, the other hot water to which is added a little soap and blue. As the sliver is delivered by either one of the tanks, it passes through a pair of squeezing rollers which remove a great deal of the water in the sliver. The latter is finally dried by winding it over and under a series of steam-heated cylinders. When the sliver leaves the backwashing machine the condition of parallelism, into which the fibres were brought by previous processes, is somewhat destroyed. For the purpose of restoring this condition to some extent, the slivers are run through a *gill box*, a machine provided with a series of steel bars set with pins that comb the slivers, a number of rollers transferring the material to and from the various bars. The oiling of the sliver is performed as it enters the gill box.

31. Oiling Before Backwashing.—In the process known as *French*, or *dry*, combing and spinning, the wool is combed after oiling and is then backwashed; thus the oil is washed out after combing, and the subsequent processes are carried out without the aid of oil. In the following, only the methods and mechanisms by which the oil is applied in the woollen trade will be considered.

32. Effect of Uneven Distribution.—There are many methods and means of applying the oil to wool in the woollen trade, the oldest, the most used, and the one considered by the majority as the best, being the method of oiling by hand. If oil is unevenly distributed over the material, the result will be noticed in the carding and spinning. Some fibres of the material will be barely touched by the oil, while others will receive more than their due proportion, which, with the refuse material often found on dyed wools, will form a coating completely covering them. This will harden gradually and affect the pliability of the fibre. The poorly oiled fibres exert a controlling influence, and the result will be a general deterioration; thus, the more even the distribution of the oil, the more nearly perfect will be the resulting yarn.

33. Oiling With Sprinkling Can.—In former times the oiling of the wool was usually attended to by the carding engineer himself. He removed his shoes and stockings and, taking a pail of warm oil, walked from right to left over the thin layers of wool on the floor, distributing the oil by dipping his hand into it and then shaking it from his fingers as he passed slowly along. Each layer of wool was whipped with poles, after the application of the oil, to mix thoroughly the oil with the wool. This is the method employed in many mills to-day, with the exception that, instead of sprinkling the oil with the fingers, a can resembling a garden sprinkler is used. This can is provided with a **T**-shaped nozzle pierced with several rows of holes.

34. Method of Sprinkling.—Suppose that 10 quarts of emulsion is to be applied to 100 pounds of wool. The emulsion should be prepared first; then 10 pounds of wool should be spread evenly on the floor in a thin layer and 1 quart of emulsion sprinkled

over it evenly. This layer of wool should be whipped, or beaten, with a long pole in order to distribute the oil as evenly as possible throughout the layer. This operation is repeated 10 times, each layer of wool being placed on the top of the preceding one, oiled, and beaten until the 100 pounds of wool is used up and the 10 quarts of emulsion applied.

35. When using the sprinkling can in oiling a lot of wool, the oil should be distributed as evenly as possible and care should be taken not to apply a double supply to any one portion of the material. The whipping, or beating, of the layers of wool should be thorough, as on this depends, to a great extent, the equalizing of the distribution of oil.

The material is then run once or twice through a *teaser*,* or *willey*, which is the name given to a machine that is used for opening and mixing, and is then ready for the operation of carding; but it is well to let the oiled material lie for a short time, for instance, over night, in order to allow the oil to penetrate the fibres. Material oiled with lard oil, however, should be carded within 48 hours, or the carding properties of the wool will be impaired owing to the stiffening of the fibre and oxidizing of the oil.

36. Oiling of Cotton-and-Wool Mixes.—In oiling all-wool mixes, each layer of material is sprinkled as it is laid down and is then beaten with poles. In cotton-and-wool mixes, however, the wool is first oiled separately. Afterwards the material is run through a teaser to obtain a better distribution of the oil on the wool. The oiled wool is then mixed in the required proportions with the cotton and again run through the teaser. If this method is not followed, the cotton instead of the wool will absorb the bulk of the oil, in which case the cotton becomes much more difficult to card, having a tendency to become stringy and to collect in bunches. Cotton-and-wool mixes should always be carded as soon as possible after the operation of teasing.

37. Oiling of Wool-and-Silk Mixes.—The same plan is followed with wool-and-silk waste mixes as with wool-and-cotton mixes. The silk, being especially hard to work, needs extra

* This word is also frequently spelt *teazer*.

carding and should be run through a carding machine previous to mixing. In order to get rid of the electricity, which is sometimes troublesome in carding, silk may be dampened by lying under wet burlap over night, being mixed with the oiled wool and carded in the morning.

When shoddy has been lying about for some time and is very greasy and gummed up, it is well to use a large proportion of water and a small proportion of oil in the emulsion that is used for lubricating.

AUTOMATIC OILING

38. Types of Automatic Oilers.—Although in many mills the old method of hand oiling prevails, there are some mills that use automatic oilers, of which there are several makes designed to oil the material at various points in the process of manufacture. The work of most of these devices is not entirely satisfactory, but it is a much more accurate method of regulating the distribution of the oil and also saves a great deal of time and space. These devices can be applied to the feeding mechanism of any of the machines through which the material will pass prior to carding. It is customary to attach the oiling device to the fearnought, though it may be applied to the burring machine. In either case it is usually one of two types, namely, the *brush oiler* or the *scraper oiler*.

39. Brush Oiler.—The oil in the form of an emulsion is poured into a large cistern supported above the machine. If the cistern is sufficiently high it may be filled conveniently from the room above by a funnel passed through a hole in the floor. A sight gauge glass, marked to register gallons, should be fixed to the cistern, so that the operator by reading downwards can record the quantity of oil or emulsion used on any particular quantity of material. In many cases, however, the oil and the water with the emulsifier are mixed in the oiling device. The oiling apparatus shown in Fig. 3, which belongs to the latter type, consists of two tanks *a* and *b*, each of which is fitted with a sight gauge glass, by means of which it can be seen how much water and emulsifier is used in a given time. Tank *a* contains the oil, and

tank *b* the water and the emulsifier. The steam coil *c* serves the purpose of heating the contents of the tank, so as to facilitate the making of the required emulsion. The pipes *f* and *g* conduct the oil and emulsifier solution to the funnel *h*, through which they combine and run into the tank, or brush bath, *i*. The taps *d* and *e* are for the purpose of regulating the supply from each tank, as required. The tank *i* and the brush *j* are made the width of the feed-lattice of the machine to which the oiling device is applied, so that the oil can be sprinkled across the whole width.

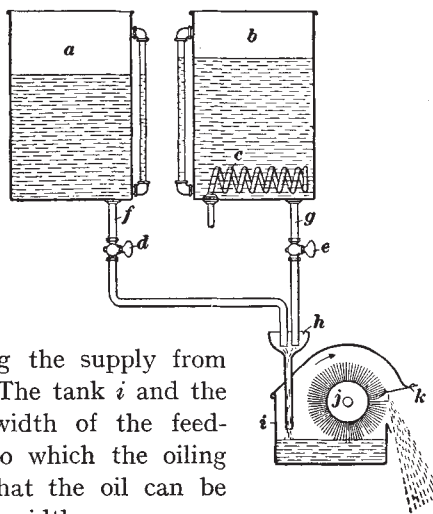

40. The brush *j*, Fig. 3, revolves in adjustable bearings, so that the tips of the long flexible bristles can be arranged so as barely to touch the surface of the oil or the emulsion, and therefore pick up but small quantities. A steel plate *k* is set slightly into the brush; therefore, when the latter revolves in the direction indicated, the bristles in contact with *k* will be retained for a moment and then suddenly released. As the bristles spring into their normal straight position they throw the small particles of oil downwards on to the wool on the travelling lattice beneath. In some oiling mechanisms of the brush type, the mixed oil, water, and emulsifier run into a separate trough, where a mixing roller keeps the ingredients well mixed. A float mechanism in the brush bath regulates the flow of the mixture coming from the mixing trough. By this means the fluid in the trough is always maintained at the same level, and the brush will always take up and deliver the same amount of oil.

41. **Faults of Brush Oilers.**—The principal faults of brush oilers is that the brushes wear out rapidly owing to the constant friction and bending against the steel plate. The brush

requires, therefore, frequent readjustment to ensure a uniform application of the oil. Unless this adjustment is the same throughout the width of the brush, one end of the brush may take up and distribute a greater quantity than the other end. There is also some difficulty in controlling the area over which the distribution of the oil takes place.

If a smooth wooden roller is made to revolve in the oil, and the brush takes the oil from off the surface of this roller, there is less risk of variation from side to side; but it is still open to the objection of the rapid wear of the brush and the difficulty of controlling the area covered by the spray.

42. Scraper Oilers.—A common form of scraper oiler is shown by means of the diagram, Fig. 4. The feeding of the oil or emulsion to the shallow trough *a* may be done

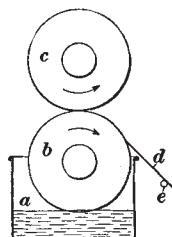

FIG. 4

by any one of the means already described. Mounted in bearings at each end of the trough *a* is a smooth-faced roller *b*, which is as long as the width of the feed-lattice of the machine to which the device is attached. Its position is so arranged that it dips for a short distance into the oil or emulsion and so carries a certain quantity round on its surface. Mounted above, and resting loosely on the roller *b*, is a similar roller *c*. The oil that passes between the two rollers is spread out into a thin, even layer on the bottom roller *b*.

43. At the front of the bottom roller *b*, Fig. 4, is a thin steel or tinned plate *d*, which is termed a *scraper*. This is fastened to a rod *e*, which is capable of turning loosely in bearings so that the upper edge of the plate will always rest lightly against the surface of the roller *b*. It acts, therefore, as a scraper, removing the oil from the roller in a thin, even layer. The scraper extends the full length of the roller, and as it is inclined at an angle of about 30 to 40 degrees with the vertical, the oil that is scraped off runs down and drips from the lower edge of the plate on to the wool passing underneath on the feed-lattice. When oiling is not required, the inclined plate is simply swung round out of contact with the roller.

44. Another form of scraper oiler is shown in Fig. 5. Here the oil or emulsion flows from the trough *a* over a projecting lip *a*₁ on to the roller *b*, revolving in the direction indicated by the arrow; the upper roller *c* distributes the oil into a thin, even film. The scraper *d* acts as the corresponding one in Fig. 4.

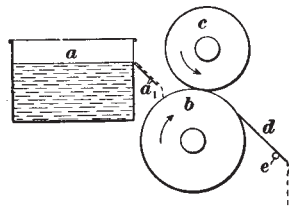

FIG. 5

45. Effect of Temperature on Brush and Scraper Oilers.—A disadvantage of all brush and scraper oilers is that they are affected by comparatively small variations of temperature. Thus, when the oil is cold and comparatively thick or stiff, the rollers or the brush will take up and distribute a much larger quantity of oil than when the oil is warmer and more fluid. It is found, therefore, that in mills where the same temperature

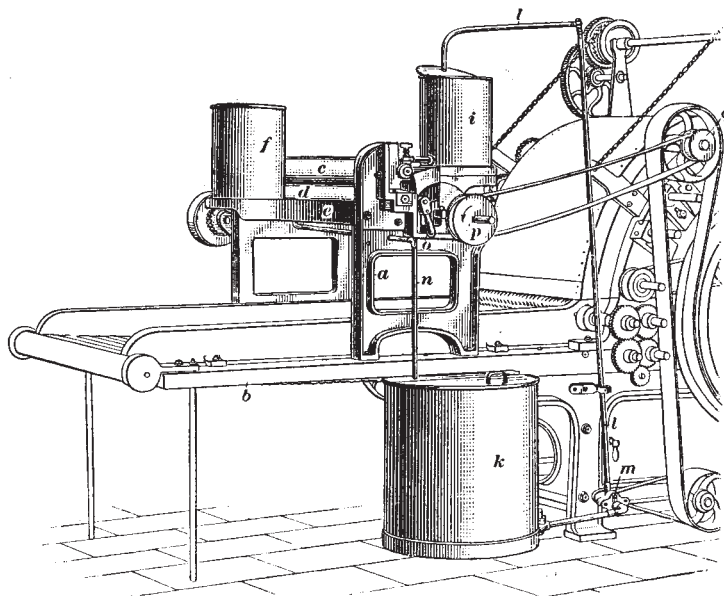
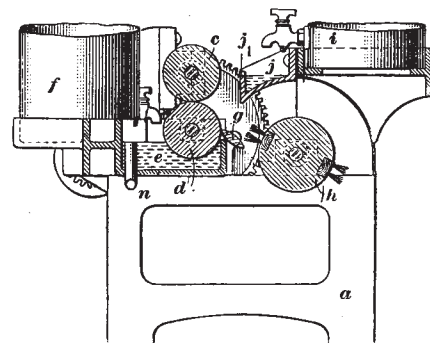
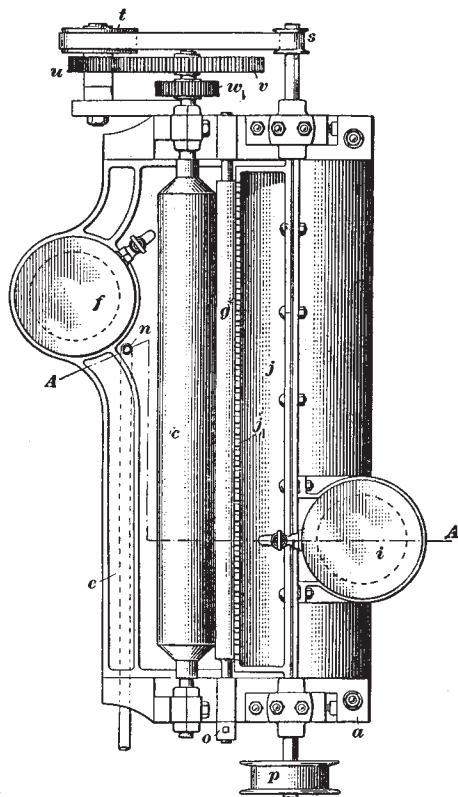

FIG. 6

is not maintained day and night, there will be a greater quantity of oil taken up by the oilers when they begin to operate in



(a)

(b)
FIG. 7

the morning than later on after the machinery has become thoroughly warmed.

46. Construction and Operation of the Sykes Oiler.—A Sykes oiling mechanism, as applied to a fearnought opener, is shown in perspective in Fig. 6, while in Fig. 7 a section is shown at (a) taken along the line *A-A* in the plan at (b). The mechanism is arranged so that oil only, oil and water separately, or an emulsion of oil and water, intimately mixed, may be applied. The same parts in all the views have the same reference letters. The frame *a* of the oiler is mounted on the feed-lattice frame *b* of the fearnought. Arranged in suitable bearings at the top of the framework *a* are two iron rollers *c* and *d*, each of which is about 4 inches in diameter. The lower part of the bottom roller *d* is immersed in the contents of the trough *e*, which is

supplied with oil from the large circular tank *f*, the tap in which projects over the trough *e*. The roller *d*, in revolving slowly, takes up on its surface a quantity of oil which the upper roller *c*, that rests on its surface, reduces to a thin film, the surplus oil flowing back into the trough. The thin layer of oil is carried forwards by the roller *d* until it reaches a scraper *g*. The upper edge of the latter rests lightly against the roller and scrapes off the thin film of oil, which flows down over the surface of the scraper until, on reaching the lower edge, it is brushed off in small quantities by a rapidly revolving beater brush *h*. This brush carries two sets of bristles, which throw the oil down on to the wool in a fine spray while it is being carried forwards by the feed-lattice to the feed-rollers of the fearnought.

47. Spraying of Water.—When water as well as oil is to be added to the material, the water, which may be ordinary water, or water mixed with an emulsifier, is stored in the cylindrical tank *i*. A tap from this tank allows the water to run into the trough *j*, which also forms part of the cover for the revolving brush. The edge *j*₁ of the trough *j* is provided with a series of notches across the whole length of the trough. The notches provide suitable outlets for the water which flows through them in tiny streams and drops down on to the inclined face of the scraper. From here the water together with the oil flows down to the edge of *g*, whence it is brushed off by the rapidly revolving brush and reaches the wool below in the form of a fine spray.

48. Spraying of Emulsion.—The large tank *k*, Fig. 6, which may contain a supply of water, is connected to the tank *i* by means of pipes *l*, a small pump *m* keeping the tank *i* supplied with water. Should it be desired to use an emulsion of oil and water, the emulsion can be mixed in the large tank *k* and supplied to the tank *i* as required. The upper end of the small pipe *n* projects through the bottom of the trough *e*, so as to be level with the surface of the oil. If an excess of oil is supplied from the tank *f*, oil will flow into the pipe *n*, which will conduct it into the large tank *k*, so that it can be used again or be made into an emulsion. The position of the scraper may be changed by means of the handle *o*.

49. **Driving.**—The pulley *p* on the brush shaft is driven by a belt from the small pulley *q* on a shaft of the fearnought. On the other end of the brush shaft, as seen from Figs. 7 (*b*) and 8,

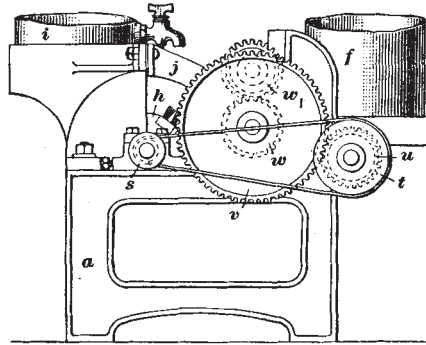

FIG. 8

there is a small pulley *s* which drives by a belt a larger pulley *t* attached to a pinion *u*. The latter drives the large gear-wheel *v* on the shaft of the lower roller *d*; on this shaft is a pinion *w* that drives a similar wheel *w*₁ on the shaft of the roller *c*. It will be seen that, by reason of the relative sizes of these wheels, the rollers *c* and *d* will revolve rather slowly. When oiling is done by supplying tank *i* with an emulsion prepared in tank *k*, the rollers *c* and *d* are disconnected by removing the belt from the pulleys *s* and *t*.

50. **Difficulties of Automatic Oiling.**—Machine oiling is not universally adopted in the woollen trade, hand oiling being still the usual method, as the different materials require such a widely different treatment with regard to the oil or solution used and the quantity applied. The position which the oiling process shall occupy relative to other processes is often difficult to determine; thus, if the oiling device is attached to a burring machine, a certain proportion of the oil is taken by the burrs and so wasted. An oiling device cannot be successfully applied to a teaser, because of the intermittent feed, and oiling cannot always take place at the fearnought, as the mix, when it reaches this machine, has generally got the cotton mixed with it, if cotton is required. The cotton would therefore absorb quantities of the oil, which would greatly affect the subsequent carding of the mix. When oil can be applied at the fearnought for all-wool mixes, then machine oiling is quite successful.

WOOLLEN CARDING

(PART 2)

FEEDING OF CARDING MACHINES

BRAMWELL AUTOMATIC WEIGHING AND FEEDING MACHINES

INTRODUCTION

1. Feeding by Hand.—The feeding of woollen carding machines is one of vital importance and should be accomplished in such a manner that the resultant yarn will have a definite count. It is necessary that a constant weight be fed to the scribbler and that the wool be uniformly spread, or delivered, in order that the best results may be obtained. Formerly, woollen-carding machines were fed by hand, the operator being provided with a pair of scales in which to weigh the material, the feed-lattice or feed-sheet being divided into uniform spaces by means of brass tacks or by painting certain laths black. A given amount of wool was weighed in the scales and spread over the area marked off on the feed-sheet; the feeding was consequently often uneven and the carding poor. The scribbler is now generally fed by a machine called an **automatic feed**, or **hopper feed**.

2. Advantages of Automatic Feeding.—The use of an automatic feed results in several advantages of which the principal ones are as follows: (a) A saving in labour, as one minder may attend two, or even three, sets of carding machines with less labour

than required by one set of machines without an automatic feed; (*b*) saving of elaborate intermediate feeds for levelling, evening, and doubling the material; (*c*) the scribbler can be left without attention for longer periods, thus giving opportunity for attending to other duties; (*d*) the material is better separated in the hopper, and felted lumps will not reach the scribbler; (*e*) the material reaches the scribbler in a more uniform layer than is possible when feeding by hand, in which case the material is weighed off by means of a pair of scales and spread on the lattice, the efficient performance of both operations depending largely on the carefulness of the minder. The uniform feeding of the scribbler is of great importance, as inequalities resulting from uneven feeding can be rectified only at the intermediate feed, a means which cannot be depended on.

3. Different Types of Automatic Feeds.—There are three distinct types of automatic feeds in use, namely: the *Bohle*, *Lemaire*, and *Bramwell*. The *Bohle* and *Lemaire* types are seldom seen in British mills, being used largely on the Continent. The one mostly used in British mills is the *Bramwell*. The machines of this type, as made by various manufacturers, differ but slightly in pattern and in the arrangement of the parts, the most noticeable differences being in the construction and method of operating the scale pan.

CONSTRUCTION

4. Principle of Operation.—An example of the modern type of the *Bramwell* automatic feeding and weighing machine is shown in perspective in Figs. 1 and 2, which represent the rear and the front end, respectively. Fig. 3 is a sectional view which shows the action of the working parts in the interior, while Figs. 4 and 5 show elevations of each side. Figs. 6 (*a*) and (*b*), and Fig. 7, show details of the device for controlling the motion of the spiked lattice. The principle on which the machine is constructed is that of automatically weighing the material that is to be fed to the scribbler, the mechanism being so devised that equal weights of the material are deposited over equal areas of the feed-lattice, so that each part of the latter shall at any time be covered

with the same quantity of material. This machine is of course only used for feeding the scribbler and is made the same width, the usual sizes being 66 and 72 inches.

5. **Hopper.**—The machine is constructed with a large feed-box, or hopper, *a*, Fig. 3, which is also shown in the perspective views, Figs. 1 and 2, similar parts in the various views being

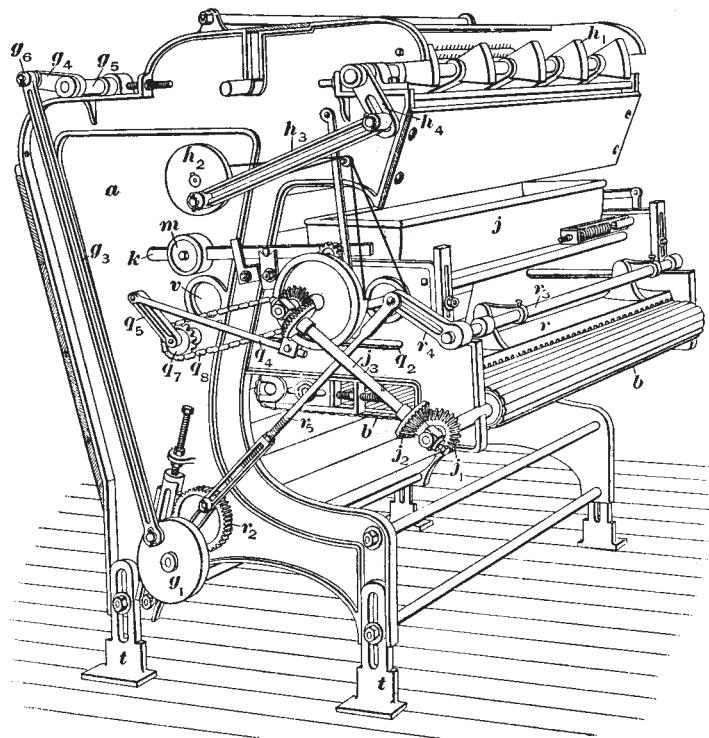

FIG. 1

indicated by similar reference letters. The relative positions and construction of the various parts will be better understood from a study of the perspective views in conjunction with the sections, elevations, or detail drawings.

The wool or other material is deposited by the attendant, or *minder*, as such a person is usually termed, in the hopper *a* until the material is level with the top of the V-shaped compartment

formed by the front a_1 of the hopper and the spiked lattice d , as shown in Fig. 3. The machine can then be left to itself and will run without attention for from 15 to 60 minutes, the length of time varying in accordance with the amount of material that is passing through the set of carding machines in a given time. The front of the hopper consists of two parts a_1 and a_2 , a_1 being hinged

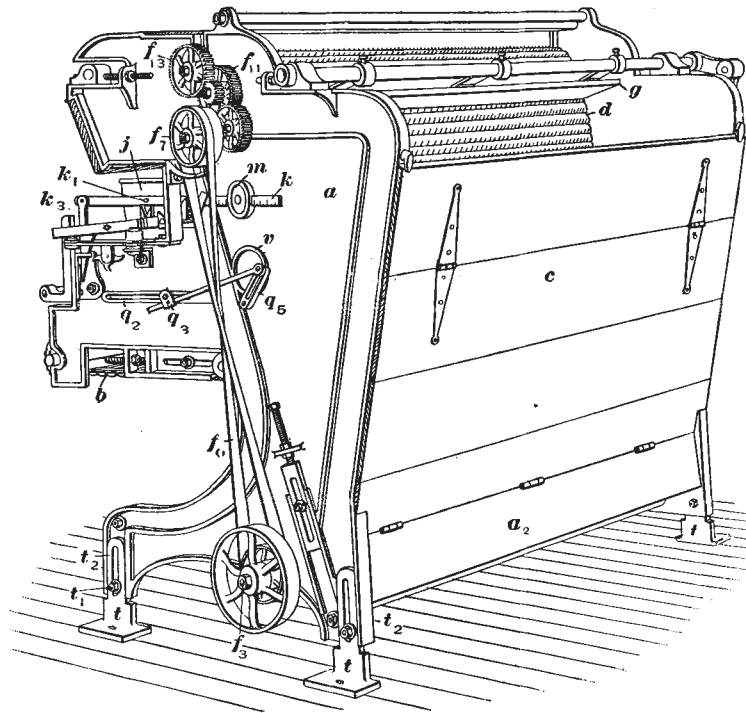

FIG. 2

at its lower end and near the top. Attached to the bottom board a_2 is a grate e which allows any foreign matter in the material to drop through.

6. Spiked Lattice.—The material is carried out of the compartment a by the spiked lattice d , which consists of laths fitted with needle-pointed pins, as shown in Figs. 1, 2, and 3; these laths are riveted to three or four parallel leather belts. The

spiked lattice receives its motion from a wooden roller or drum *f*, which is 5 or 6 inches in diameter and is guided by the bottom roller *f*₁ by means of which it may also be tightened. By making the roller *f* large, the driving of the lattice will be more

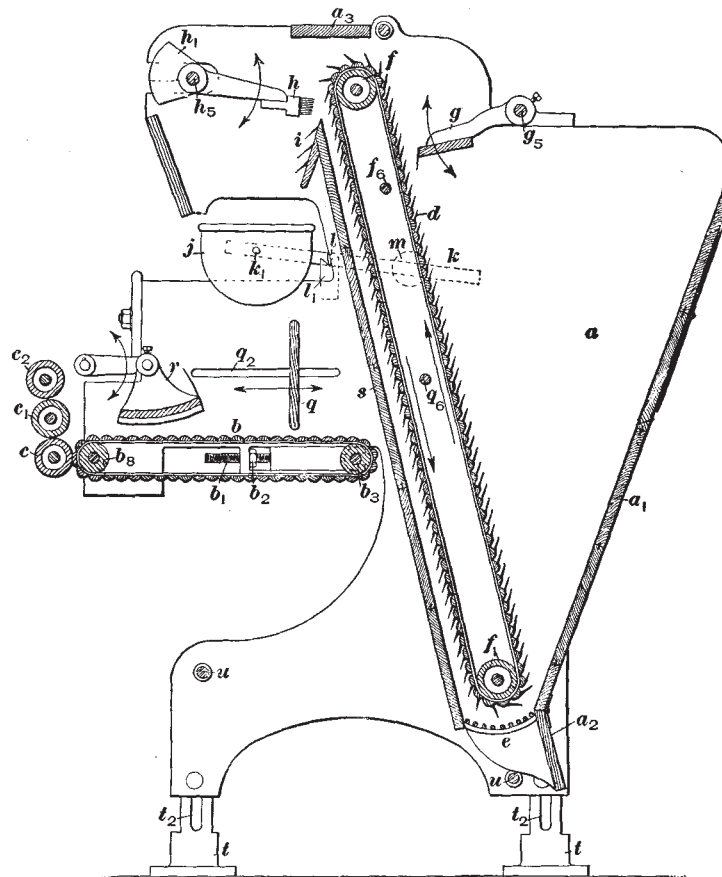

FIG 3

positive. In some cases the roller *f* is so placed, relative to *f*₁, that the lattice *d* will run nearly vertical in the hopper, but this arrangement has the disadvantage of taking the longer material first, when mixed qualities are being carded, so that after the filling up of the hopper the material at first delivered is better in

quality than the average. As the material gets lower in the hopper the machine delivers a material of lower quality. If there is to be a perfect mixing of the material, it is in such cases necessary to use expensive and elaborate *intermediate feeds*, that is, feeds that pass the material from one machine to another in a set of carding machines.

By inclining the spiked lattice as shown, the weight of the material forces it more strongly against the lattice than when the latter is vertical, with the result that the lattice spikes will pick up short fibres as readily as the longer ones; thus a more uniform feed is obtained, combined with less rolling of the material in the hopper.

7. Beater.—In the upward movement of the spiked lattice the material is impaled on its teeth and is thus taken upwards; but in order to make the supply as even and as level as possible across the whole width of the machine, an oscillating spiked *beater*, or, as it is often termed, *stroker*, *g* is used. This stroker has a stroke of about 9 inches, and makes about 80 strokes per minute; it will beat off any material that is not firmly fixed on the teeth of the spiked lattice. The beater will also to some extent break up or open out any matted pieces that may have escaped the action of the previous opening machines. The beater is usually set about $\frac{1}{4}$ to $\frac{1}{2}$ inch from the spiked lattice, and so allows only well-opened and finely divided material to pass forwards.

8. Stripping Brush.—The material after passing the stroker *g* moves along with the spiked lattice over the roller *f*, and then almost immediately comes under the action of the *stripping comb*, or *brush*, *h*, which is balanced by a number of weights similar to h_1 , also shown in Fig. 1. The brush *h* is made to give about 120 strokes per minute, and, as will be seen from Fig. 3, acts on the backs of the spikes, the material being swept down over an inclined board *i*, which is set with spikes, into the scale pan *j*. The latter is supported by long arms *k*, provided with adjustable weights *m*, so that they may be delicately balanced on the knife edges *l* resting in pans, as shown. It is understood that there is an arm *k*, and an adjustable weight *m* at each end of the scale pan *j*. When sufficient material has been fed into the scale pan *j*

to counterbalance the weight m , the pan will descend and the lattice d will stop at once by means of devices yet to be explained. At the same time the brush h also stops, so that no more material is brushed from the spiked lattice.

9. Push and Patting Boards.—The scale pan j , Fig. 3, is overturned at certain intervals by means of a mechanism, described farther on, and deposits the material on the feed-lattice b , which carries it to the feed-rollers c , c_1 , c_2 of the scribbler. The quantity of wool deposited by each overturn of the pan is called a *weigh*. The material on the lattice is not evenly distributed, and as it is also desirable that it should be in a more compact condition, it is pushed together by a *push board* q , which moves backwards and forwards each time the material is dropped on the feed-lattice b . The speed at which the lattice moves is such that the last weigh overlaps the preceding one by 1 to 2 inches.

For the purpose of making the surface of the material more even, there is an oscillating *patting board* r which periodically descends and lightly pushes down the underlying wool, so that the material reaches the feed-rollers in an even and uniform condition. The back s of the hopper extends from the board i down to the grate e . The feed-lattice b may be a part of the hopper, as shown, or may be fixed to the frame of the scribbler.

DRIVING OF PARTS

10. Adjusting Feeder to Scribbler.—The working parts previously described, and shown in Figs. 1, 2, and 3, are all supported by two side frames, one on each side of the machine. The whole machine rests on adjustable feet t , so that it can be set higher or lower and levelled to the feed-rollers of the scribbler by loosening the nuts t_1 , the slots t_2 allowing ample means of regulation. The frames are rigidly connected by means of the stayrods similar to u , held in place by nuts, as shown. Large handholes v in the frames facilitate the loosening of the spiked lattice, in case it for some reason should stick. A board a_3 is placed over the top of the machine so as to cover the spiked lattice and the stripping brush h .

11. Driving Spiked Lattice.—Motion is given to the spiked lattice from the breast cylinder of the scribbler by means of an open belt which drives the pulley f_2 , Fig. 4, on the shaft f_3 , also

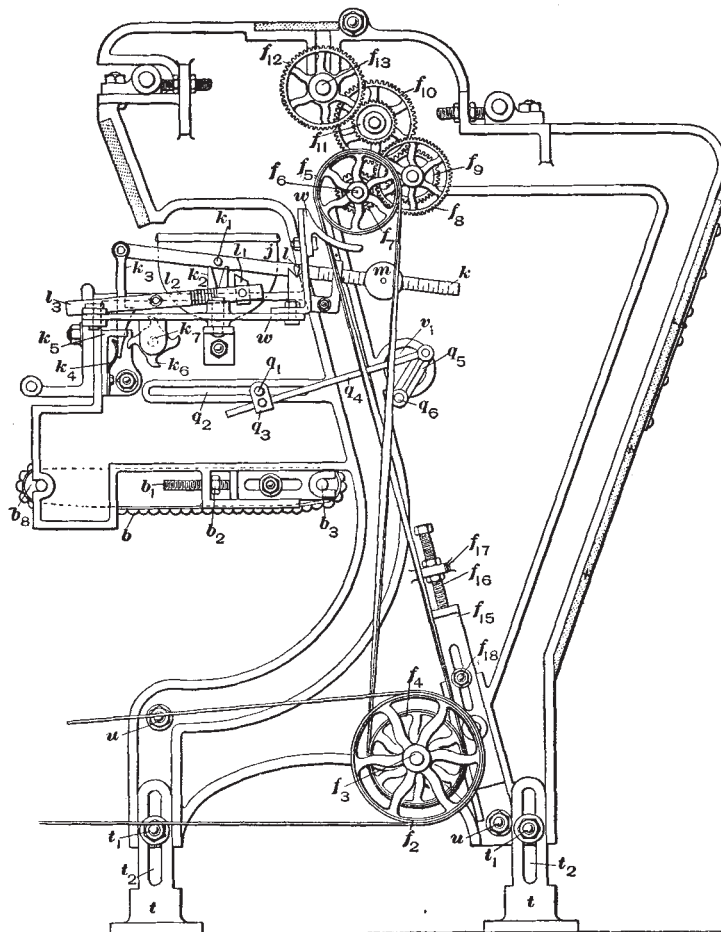

FIG. 4

shown in Fig. 5. A smaller pulley f_4 on the shaft f_3 drives by means of a crossed belt the fast and loose pulleys f_5 . The shaft f_6 on which these pulleys are placed passes through the hopper, as seen in Fig. 3; this shaft also carries a small pinion wheel f_7 which

gives motion to the gear-wheel f_{12} through gear-wheels f_8, f_9, f_{10} , and f_{11} . The gear-wheel f_{12} is fastened on the shaft f_{13} of the drum f that gives motion to the spiked lattice. The belt that

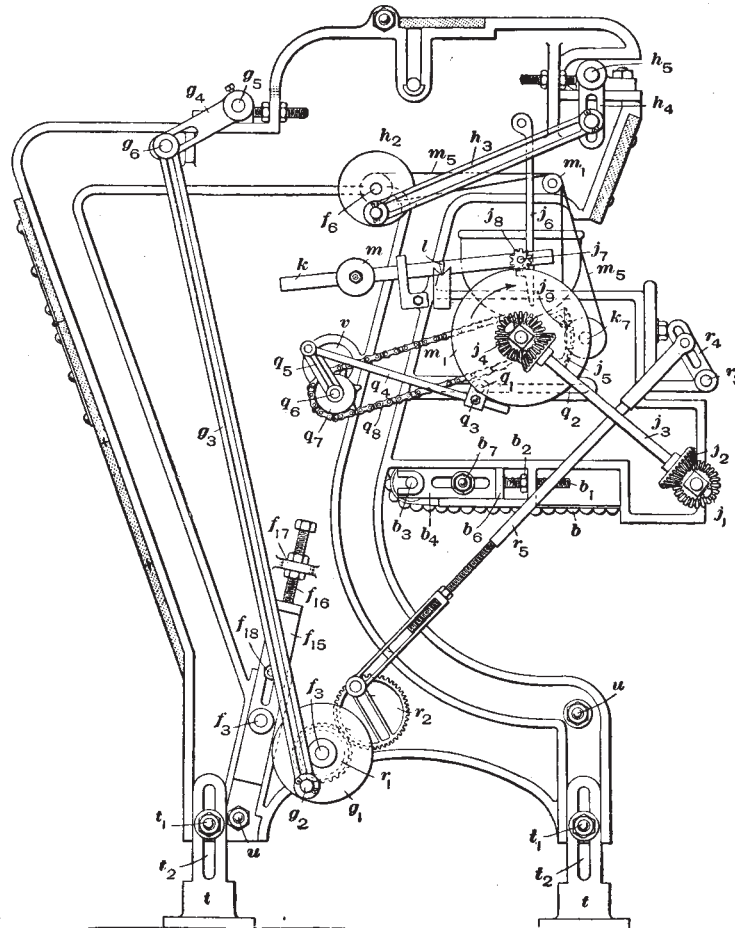

FIG. 5

drives the pulleys f_5 is controlled by the belt guide w ; when the belt is on the loose pulley the spiked lattice is stationary, but when guided on to the fast pulley the train of wheels and the spiked lattice revolve.

12. The spiked lattice is tightened by means of the lower roller f_1 , Fig. 3. The journals of the roller f_1 , which are usually termed *gudgeons*, rest in the blocks f_{15} , Figs. 4 and 5. These blocks can be set lower or higher, as required, by means of bolts f_{16} that pass through projections f_{17} of the framing. The lower end of the blocks slide between ribs on the frame, as shown, and are secured to the framing by means of nuts or bolts f_{18} which pass through slots in the blocks.

13. **Driving Stroker.**—The stroker g , Fig. 3, receives its motion from the shaft f_3 , Fig. 5, this shaft being driven, as described in Art. 10, and as shown in Fig. 4. To the shaft f_3 , Fig. 5, is keyed a crank-disc g_1 with a crankpin g_2 , which by means of the rod g_3 gives an oscillating motion to the arm g_4 of the stroker shaft g_5 , Fig. 3. The length of the stroke given to the arm g_4 , and thus to the stroker g , can be varied by changing the position of the stud g_6 in the slot of the arm g_4 .

14. **Driving Stripping Brush.**—The stripping brush h , Fig. 3, obtains its motion from the crank-disc h_2 , Fig. 5, by means of the connecting arm h_3 and the lever h_4 which is keyed to the stripping brush shaft h_5 . The shaft f_6 of the crank-disc h_2 passes through the hopper and receives its motion from the other side by means of the fast pulley f_5 , Fig. 4; it will thus be seen, when the belt is moved on to the loose pulley at f_5 , that both the spiked lattice and the stripping brush will remain stationary. The sweep or stroke of the stripping brush may be varied by altering the position of the stud in the slotted arm h_4 .

15. **Driving Patting Board.**—The patting board r , Fig. 3, is driven so as to make about 40 to 50 pats per minute by means of the speed-reducing gear-wheels r_1, r_2 , Fig. 5. The patting-board shaft r_3 receives motion in the usual manner through the slotted arm r_4 and the long connecting-rod r_5 , this rod being attached to the gear-wheel r_2 by means of a stud, as shown. The rod r_5 is divided into two parts and can be lengthened or shortened by screwing the threaded end of one part into that of the other, a locknut taking up any play. It is thus possible to set the patting board nearer to or farther from the feed-lattice by this means

and to regulate the amount of pressure put on the material while it travels on the lattice b toward the feed-rollers of the scribbler.

16. Driving Push Board.—At each end of the push board there is a stud q_1 , Fig. 4, passing through a horizontal slot q_2 in the side frame. To the outer end of the stud is fastened one end of the connecting-rod q_4 by means of the small block q_3 , the other end being attached to the lever q_5 which is fixed on a shaft q_6 . This shaft passes through the hopper and receives its motion by means of a sprocket gear-wheel q_7 , Fig. 5, through the chain q_8 and a similar sprocket wheel q_9 , Fig. 6, which results in one traverse of the push board being made to each weigh of the scale pan.

17. The feed-lattice b , which is shown in Figs. 1 to 5, is tightened by means of the bolt b_1 and the nut b_2 , Figs. 4 and 5. The shaft of the back roller b_3 of the lattice rests in the neck of the casting b_4 , which is provided with a slot b_5 . The bolt b_1 is attached to the projection b_6 on the casting b_4 ; hence, by turning the nut b_2 in the proper direction, the casting b_4 can be moved toward the hopper, thus tightening the lattice. The casting b_4 , after its adjustment, is firmly secured by a nut b_7 .

CONTROLLING MECHANISM

18. Balancing Scale Pan.—The adjustment of the amount of material fed to the scale pan is the first of the factors that control the periods at which the scale pan empties. This adjustment is brought about in the following manner: On each of the arms k , Figs. 4 and 5, is fixed an adjustable weight m ; the positions of these weights determine the amount of material required to balance them. The nearer the weights m are to the knife edges l , the smaller is the weight of material required to balance them, and vice versa. To make a light weigh for fine counts the weights m are moved nearer to the knife edges l , and for thicker counts farther away.

19. Positive Descent of Scale Pan.—While the material is falling into the scale pan, all the parts are in the positions indicated in Figs. 4 and 5. As the filling of the pan continues,

its weight will eventually more than balance the weight m , the material thus causing the scale pan to descend about 2 inches, so that the stud k_1 , Fig. 4, drops into the fork k_2 , bolted to the framing. At one end of the arm k there is a hook k_3 which is forced forwards by a flat spring k_4 , while a small bracket k_5 guides

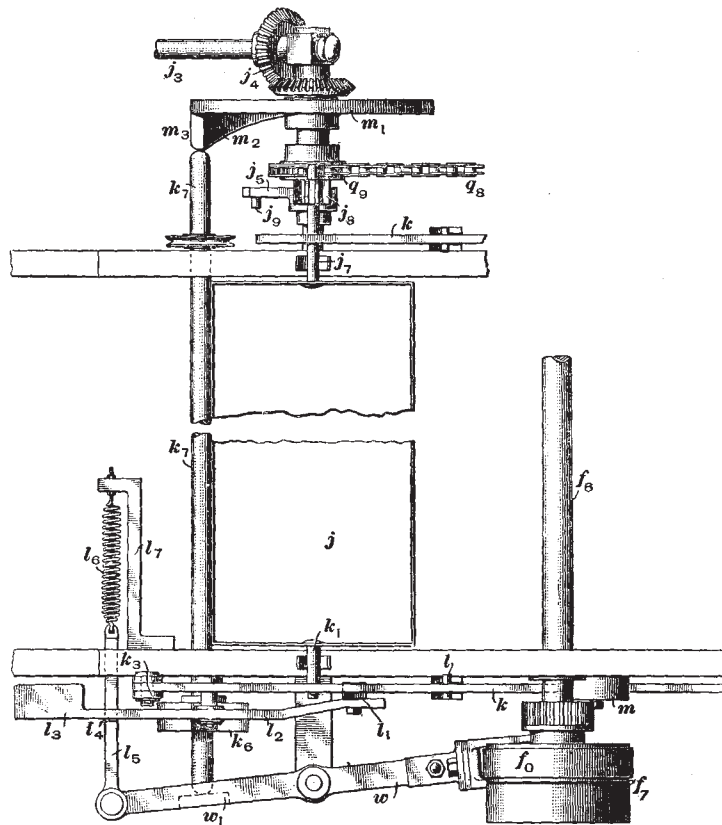

FIG. 6

the hook in its downward motion. When the hook k_3 has descended through a given distance, it engages with the revolving wheel k_6 on a shaft k_7 . This wheel is provided with peculiarly shaped teeth, one of which will engage the hook k_3 and pull it downwards, thus ensuring a quick motion of the scale pan during

the final portion of its descent. The wheel k_6 receives its motion from a pulley at the other end of the shaft k_7 driven by a band from a pulley on the shaft f_6 .

20. Stopping Feed Mechanism.—Some of the parts connected with the scale pan are shown on a larger scale in Figs. 6 and 7 (a) and (b). Fig. 6 is a plan view that shows the pan and the parts employed in emptying it, and Fig. 7 shows in side elevation two positions of the parts that stop the feeding mechanism. It is necessary that the descent of the scale pan should, to some extent, be positive, in order that the arm k may depress the small wedge-shaped casting l_1 on the lever l_2 , Fig. 4, and thus raise the weighted rear end l_3 .

The latter is normally resting against a nose l_4 formed on the rod l_5 , as shown in Figs. 6 and 7. This rod, and therefore also the nose l_4 , is constantly pulled against the lever l_2 by means of the spring l_6 fastened to the bracket l_7 , Fig. 7.

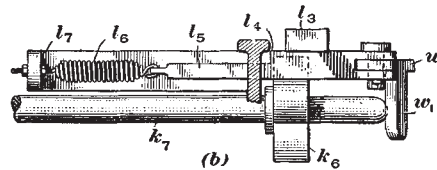
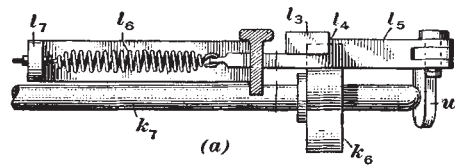

FIG. 7

The other end of l_5 is pivoted to the belt-fork lever w , which moves the belt f_0 on to the fast and loose pulleys f_7 . The relative positions of these parts, while the pan j is being filled, are shown in Figs. 6 and 7 (a), the belt f_0 being on the fast one of the pulleys f_7 . When the pan j descends and the lever k forces down the block l_1 of lever l_2 , the end l_3 will rise free of the nose l_4 , and the spring l_6 will contract and pull the rod l_5 inwards, thereby moving the lever w so as to shift the belt f_0 to the loose one of the pulleys f_7 . As a consequence, the lattice roller f , with the spiked feed-lattice, and the brush h will stop.

21. Emptying Scale Pan.—The time required for filling the scale pan may vary, depending on the specific weight of the material, but the filling will always continue until the pan has

received the required amount, which will, in general, require one revolution of the spiked lattice. While the filling is taking place, the feed-lattice b will have time to carry the last weigh toward the roller c , Fig. 3, and nearly out of the way before the scale pan deposits the next weigh on the feed-lattice.

22. The mechanism for emptying the scale pan is shown in Fig. 5, and operates as follows: On the shaft of the feed-lattice roller b_8 is a bevel wheel j_1 which gives motion to another bevel wheel j_2 on a connecting shaft j_3 ; on the other end of this shaft is a bevel wheel which, through bevel wheel j_4 , transmits motion to a sleeve that revolves on a stud bolted to the framing. Fixed on the sleeve is a small toothed sector j_5 with 10 teeth, also shown in Fig. 6; when the scale pan descends to its lower position it allows a small loosely pivoted hook j_6 , termed a *holding-down hook*, to swing over and engage with the stud j_7 of the scale pan and so keep it down. On this stud is a small gear-wheel j_8 with 10 teeth, which the sector j_5 engages when it comes round, and thus turns the scale pan completely round, causing its contents to be deposited on the feed-lattice. In one form of the revolving scale pan the pan does not make a complete revolution, but simply turns upside down and then returns to its original position.

23. Release of Scale Pan.—As soon as the scale pan is emptied it must be released for the purpose of being refilled. In its present position it is held down by the two hooks j_6 and k_3 , situated at the ends of the pan. The hook j_6 , Figs. 5 and 6, is pushed sidewise by a small pin j_9 situated on the inside of the sector j_5 . This pin pushes the hook j_6 away from the stud j_7 at the moment when the last tooth of the sector leaves the pinion j_8 . The hook k_3 is released in the following manner: On the sleeve of the sector j_5 , Fig. 6, is a disc m_1 provided with a wedge-shaped rim m_2 that makes contact with one end of the shaft k_7 . This shaft, which carries the wheel k_8 at its other end, is forced against the rim m_2 by means of a projection w_1 on the lever w , while the latter is subjected to the pull of the extended spring l_6 . When the lattice d is stopped and the pan is being emptied, the wheel k_8 is under the lever k , so as to make contact with the hook k_3 which at this moment is supposed to be held by the wheel k_6 .

24. While the pan is held down by the hook k_3 , Fig. 6, the disc m_1 continues its revolutions; the rim m_2 will therefore eventually begin to move the shaft and wheel k_6 longitudinally away from the hook k_3 until the latter is released and the scale pan is free to move upwards under the downward pull of the weights m . Simultaneously the shaft k_7 has been pushing one end of the lever w outwards until it occupies the position shown in Fig. 6, in which the belt f_0 is moved to the fast pulley and the lattice d set in operation. In this position the lever end l_3 is allowed to drop back of the nose l_4 ; consequently, when the highest point m_3 of the rim m_2 passes the end of the shaft k_7 , the latter will remain in the position shown in Fig. 6, because the spring l_6 is prevented from pulling the lever w back. The various parts are now returned to their original positions and the filling continues in the manner previously described.

OTHER FEEDING DEVICES

WING, OR DIVIDING, SCALE PAN

25. **Opening Action.**—The action of the wing or dividing scale pan is shown in Fig. 8. On the end of the front shaft of the feed-lattice to the scribbler there is a bevel wheel a , which gives motion to the gear-wheel b through bevel gear-wheels and connecting shaft. The gear-wheel b drives a gear-wheel c , which has a pin c_1 fixed on the inside. After the scale pan is filled and the spiked lattice feed is stopped, it remains at rest until the pin c_1 comes in contact with the projection d_2 on the lever arm d_1 of the lever d , which has its fulcrum on a stud e . As the lever arm d_1 is moved to the right by the pin c_1 , the upper arm d_3 is lowered and presses down the pin f_1 , fastened to the lever f and working in a slot of the lever g ; these levers are attached to the wings i, i_1 of the scale pan. As the pin f_1 is pressed down, the wings of the scale pan are opened into the positions shown by the dotted lines and the material is allowed to fall on to the feed-lattice. After the pin c_1 passes from contact with the projection d_2 , the lever d

returns to its original position by means of the weight *i*, while

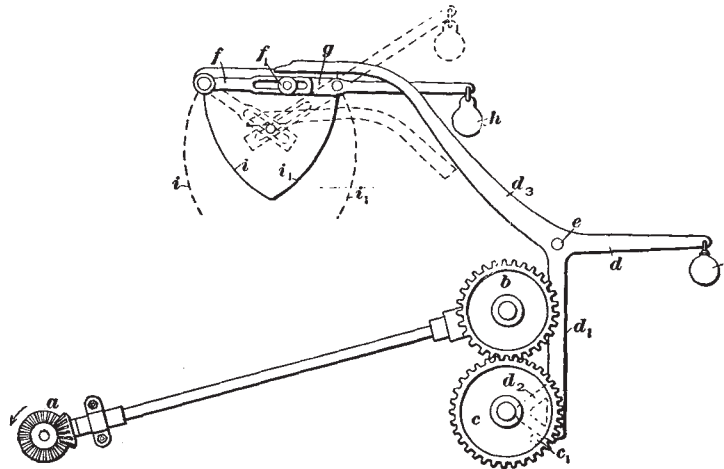

FIG. 8

the wings of the scale pan are brought together by means of the weight *h*.

26. Revolving and Wing Scale Pans Compared.—Compared with the wing type the revolving scale pan has the advantage that it must contain a certain weight of material before it will empty itself. If the hopper has become so nearly empty that there will not be sufficient material to fill the scale pan, it will not descend and, consequently, will not set in operation the various motions that empty it. The belt *f*₀, Fig. 6, will not be shifted over to the loose pulley because the lever *l*₂ will not release the rod *l*₅; hence, the spring *l*₆ cannot move the lever *w* so as to throw the belt over. The feed-lattice will continue its motion, and as the pan has not deposited any material, there will be an empty space on the lattice. When the next opportunity for emptying itself arrives, the pan will probably be filled, and will therefore descend and be turned over. But the empty space on the lattice will indicate that one weigh has been omitted and that it must be supplied by hand. The wing type opens periodically its pan and deposits on the feed-lattice whatever material it may contain, and thus the weigh may at times be too light without indicating that

such is the case. As a result, the rovings at the condenser will be too light, causing considerable waste at this point, or, if not rectified, the fault will show itself in the spinning or weaving process.

BOHLE FEED

27. **Operation.**—The object of the Bohle feed is to convey the material from the hopper to the first scribbler cylinder by means of a series of rollers without weighing the material, depending on the fact that the rollers will take up, approximately, a constant amount. The diagram, Fig. 9, shows the general features of the machine. The material in the hopper *a* is moved toward the

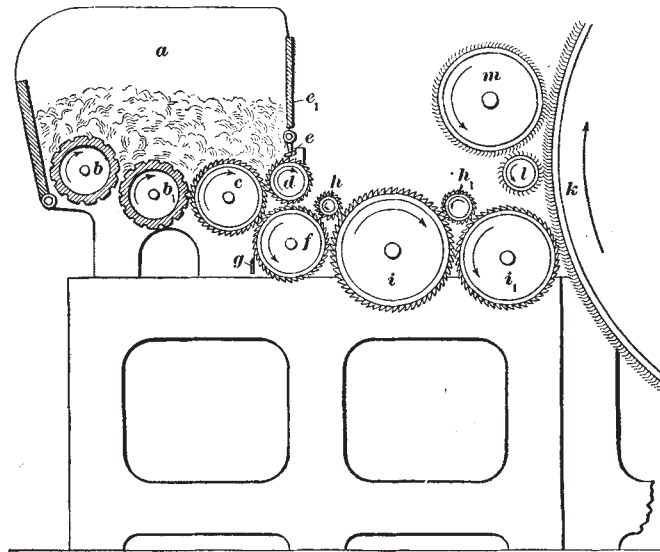

FIG. 9

feed-roller *c* by the slowly revolving fluted rollers *b*, *b*₁, made of wood. The feed-roller *c* is stripped of its surplus material by the slowly revolving worker *d*; the material on the latter roller is removed by the oscillating doffing comb *e* and returned to the hopper. The feed-roller *c* carries forwards a uniformly thick layer of material to the roller *f*, which, by reason of its greater surface velocity, clears the feed-roller. When leaving the latter roller

the material is in a somewhat open condition, and extraneous matters will therefore separate themselves from the surrounding fibres and drop down. A burring knife *g*, set close to the roller *f*, will help in freeing the material of burrs and other hard substances. The roller *i*, by reason of its higher speed, clears the roller *f*, and is in turn cleared by the roller *i*₁ which runs at a still higher speed. The latter roller is stripped by the cylinder *k*, the material being now acted upon in the usual manner by strippers *l* and workers *m*. Workers *h* and *h*₁ assist in opening the material in its passage to the cylinder *k*.

LEMAIRE FEED

28. Principles of Operation.—In the Lemaire automatic feed the feed-lattice of the scribbler is provided with a uniform layer of material by means of a roller and a doffing comb. In the diagram, Fig. 10, *a* is the hopper that receives the material. A roller *c*, provided with a series of spikes, picks up the material, brought

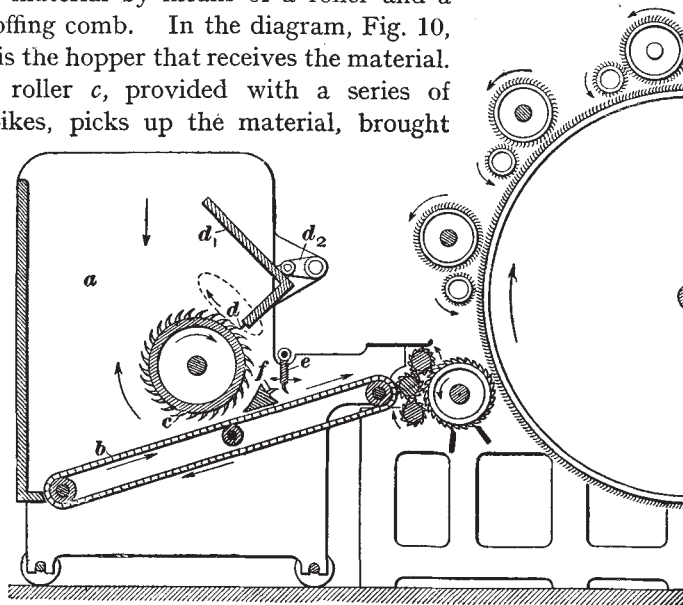

FIG. 10

forwards by the lattice *b*, and carries it toward the stripping comb *d* fastened to a movable partition *d*₁, the lower part

of which is connected to cranks d_2 . If the upper part of d_1 is suitably guided, while the lower part participates in the motion of the cranks d_2 , the comb d will follow an elliptical path as indicated by the dotted line. The comb removes the surplus material from the distributing roller c and returns it to the hopper; an even layer of material is, however, allowed to pass toward the stationary comb f . An oscillating comb e pulls the material from the roller c through the comb f and delivers it to the lattice b . The successful operation of this automatic feed depends on the uniformity of the layer that is allowed to pass the comb d .

INTERMEDIATE FEEDS

PRINCIPAL FUNCTIONS

29. Rearrangement of Fibres.—The general effect of carding is to straighten the fibres and to arrange them so that they will point in the direction in which they move through the machine. As the fibres in a well-made woollen thread should cross one another in all directions, means must be found by which the parallelism of the fibres may be destroyed. It is the function of the intermediate feed to effect this rearrangement, so that the relative positions of the fibres will be more irregular. While feeding the material evenly to the lattice of the carder, the intermediate feed should at the same time deliver the material in such a manner that the fibres will point in a direction across the lattice.

30. Mixing of Material.—The intermediate feed should also provide a means for evening out inequalities that result from the fact that the scribbler does not deliver a sliver possessing a uniform thickness throughout the width of the machine. This lack of uniformity may be the result of an uneven distribution of the material in the hopper. If there is an excess of material on one side, it will press more heavily against the feed-lattice and will be more readily taken up by it; this will cause the material to be heavier on that side of the card. Inequalities in the sliver are

also produced by the mixing of the waste from the condenser with the ordinary raw material. This waste consists of material that, during carding, was subjected to a cleaning process by which it was freed from shives, dirt, and other extraneous matter; consequently, when weighed off by the scale pan, it will contain more woollen fibres than a similar weigh of material, not cleaned. If the hopper is filled with waste only, a heavier roving will be delivered at the condenser. To avoid this, it is necessary that the waste be thoroughly mixed with ordinary material placed in the hopper. Inequalities in the roving are also produced by the fancy, which has a tendency to throw the material toward the middle of the cylinder, while the angle strippers tend to roll the material toward the sides of the cylinder.

SCOTCH FEED

31. General Arrangement.—Fig. 11 is a perspective view of a Scotch feed which shows how the web is conveyed from the doffer *b* of the scribbler *A* to the lattice *c*, from which it is transferred in the form of a sliver *a* over the overhead lattice to the lattice *h* of the intermediate *B*. Figs. 12 (*a*) and (*b*) are front and side elevations, respectively, of another make of the same type of feed, showing how the material is taken from the scribbler and carried by an overhead lattice in the form of a sliver to an adjoining machine. In Fig. 13 (*a*) the sliver is being laid on the feed-lattice of the machine to which it has been carried. Referring to Fig. 12, the web, which is doffed by the doffing comb from the last doffer *b* of the scribbler or intermediate, drops on a travelling lattice *c*. This lattice, which is about 7 inches wide, conveys the material, or sliver, to one side of the doffer in the form of a ribbon about 3 to 4 inches wide and 1 inch thick. The sliver passes between the heavy rollers *d*₁, *d*₂, *d*₃, where it is compressed, and is then pulled upwards by an overhead lattice *e*, which conveys it for some distance in a horizontal direction. From this lattice the sliver passes over a roller *l*₇ and down toward the feed-lattice *h* of the adjoining machine, as shown in Fig. 13. The sliver is deposited on the lattice and arranged in a certain

manner by means of a pair of rollers f, f_1 , which are mounted on a carriage g that travels from side to side of the feed-lattice. As this lattice moves simultaneously with the feed-lattice, the

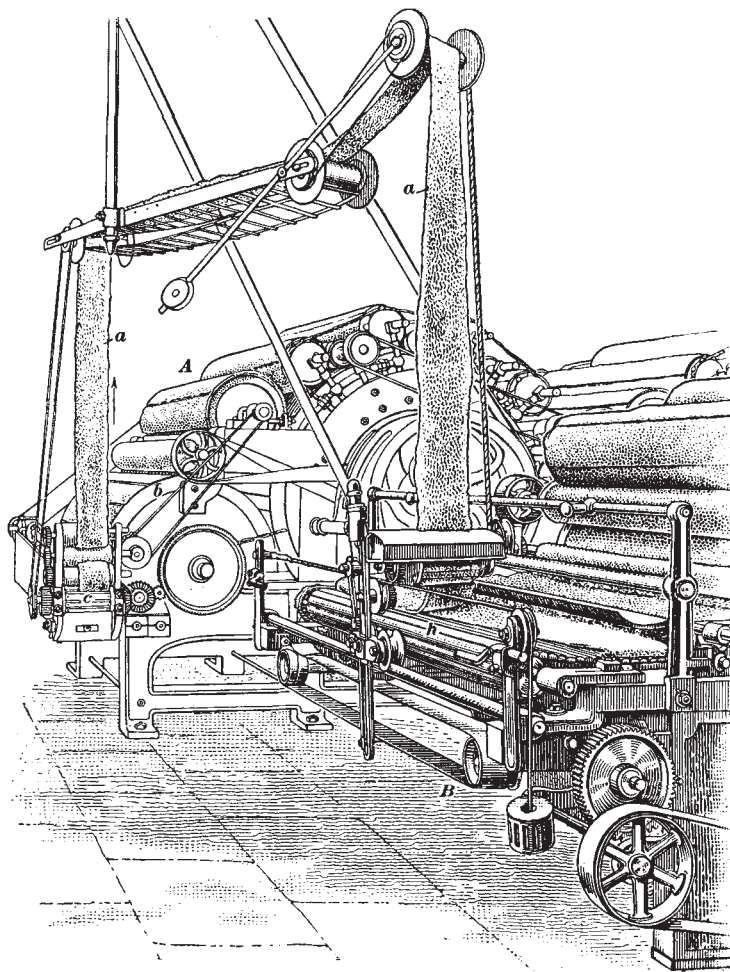
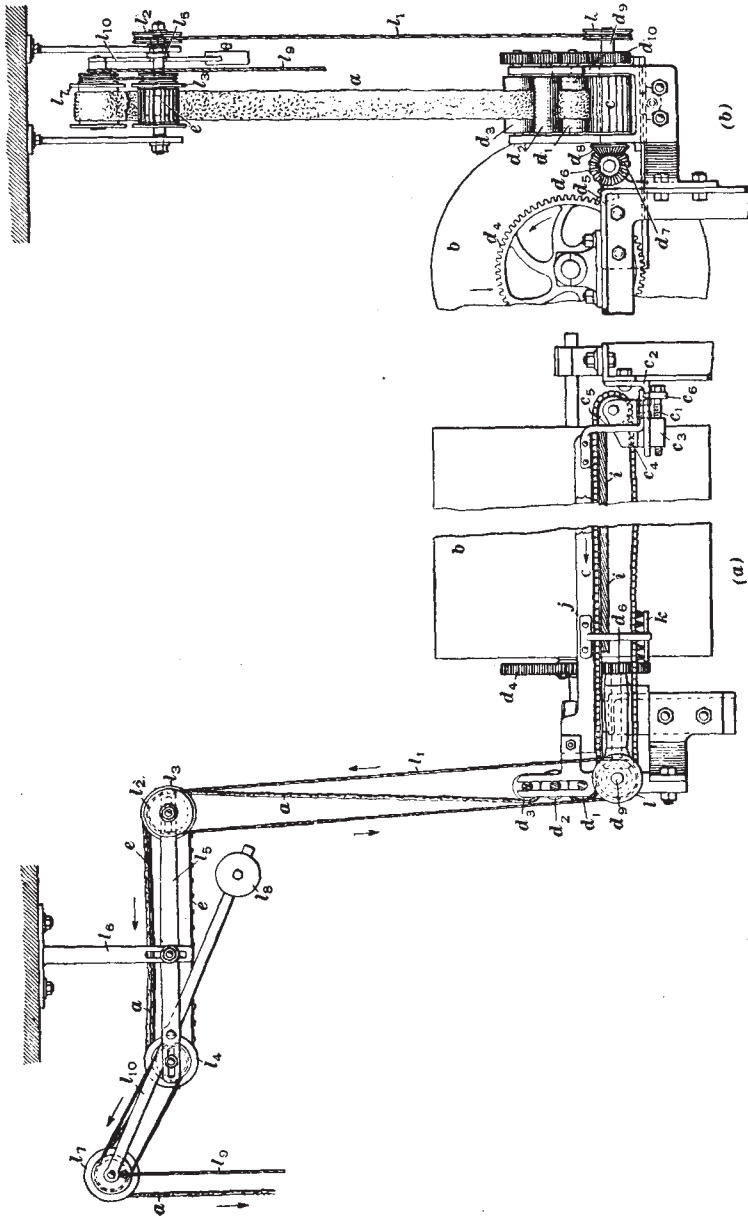

FIG. 11

layers of the sliver will assume a zigzag form and each layer will overlap the preceding one by a couple of inches in the manner shown in Fig. 14, which is a plan view of the feed-lattice h .



32. **Formation of Web Into Sliver.**—The web, after it is removed from the doffer *b*, Fig. 12, drops on the lattice *c*, the upper portion of which rests on a board *i*. The lattice receives its motion from the roller on the shaft *d*₉, which is driven by the

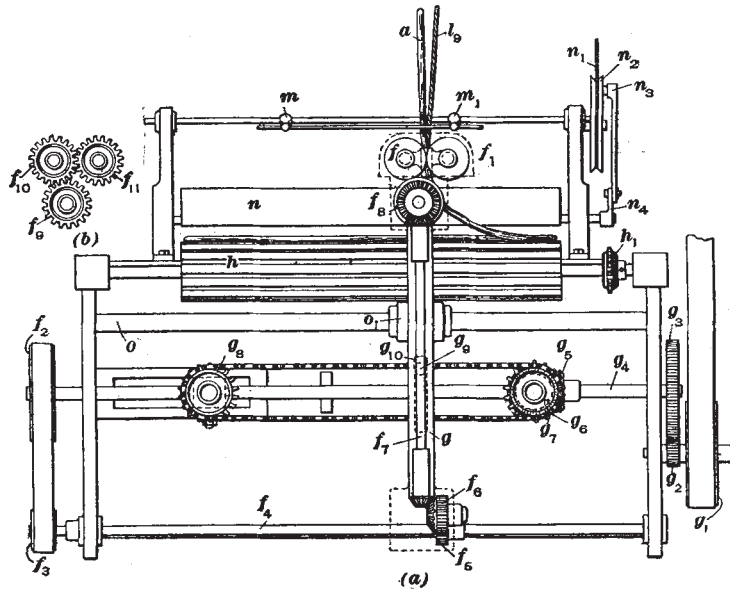

FIG. 13

doffer wheel *d*₄ by means of the carrier *d*₅ and a change wheel *d*₆ to which is attached a bevel wheel *d*₇. The latter drives a bevel wheel *d*₈ which is attached to the roller shaft *d*₉, thus imparting motion to the roller and lattice *c*. A wheel *d*₁₀ on the shaft *d*₉ drives the press rollers *d*₁, *d*₂, *d*₃ through a train of gear-wheels, as shown. The shafts of these rollers rest in a slot formed in the supporting casting, as shown in Fig. 12 (*a*).

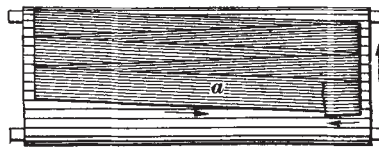

FIG. 14

The lattice *c*, which extends from side to side of the doffer, may be tightened by means of a bolt *c*₁, mounted in a bracket *c*₂, which is bolted to the

framing. This bracket has a slot through which passes a projection c_3 of the casting c_4 ; the latter rests on the bracket c_2 and supports the roller c_5 round which the lattice c passes. By turning the bolt c_1 , which is threaded through c_3 , in the proper direction the casting c_4 is moved to the right and thus tightens the lattice. Fixed to the board j is a brush k which cleans the travelling lattice and also acts as a support. When the web leaves the offer it has a width nearly equal to the latter. While falling on the moving lattice c the web is pulled sidewise, and the material contained in the web, while at full width, is condensed into a narrow space of about 3 to 4 inches; consequently, the resulting sliver will be much thicker and be able to sustain the stress it will undergo in being transferred from one machine to another.

33. Driving Overhead Lattice.—The overhead lattice e , Fig. 12, is driven from a rope, or band pulley, l by means of a rope l_1 , which transmits motion to a pulley l_2 on the shaft of the drum l_3 round which the lattice passes. This drum and the other drum l_4 are supported by the bar l_5 , which is provided with slots to permit relative adjustment of the drums; the bar l_5 is bolted to a bracket l_6 fastened to the ceiling. After the sliver a is conveyed forwards by the lattice e , it passes round the drum l_7 , which is driven by a band from a pulley on the shaft of the drum l_4 , as shown. The drum l_7 is supported by a lever l_{10} pivoted on a stud on the bar l_5 and balanced by a weight l_8 ; the bar l_{10} is sometimes pivoted on the same stud as that on which the drum l_4 revolves. The reason for supporting the bar l_{10} on a pivot is to allow of an up-and-down motion, so as to relieve the sliver of any excess of tension as it is being fed by the rollers f and f_1 , Fig. 13, on to the feed-lattice h . This swinging motion is produced by means of a cord l_9 , Figs. 12 and 13, one end of which is attached to the stud on which the drum l_7 revolves and the other end to the carriage g . As the carriage travels backwards and forwards across the feed-lattice, the roller l_7 is drawn down or released by the cord l_9 . When the carriage is approaching either side of the lattice, an increased downward motion is given to the lever l_{10} by means of the device shown in Fig. 13. Here two adjustable studs m , m_1 are placed in the path of the rope l_9 , so that, for instance, when the

carriage moves to the right, it will, after the rope makes contact with the stud m_1 , pull the rope in a horizontal direction through a distance nearly equal to that traversed by the carriage. As a consequence, the lever l_{10} will at this period move through a larger angle.

34. Driving Feed-Lattice and Carriage.—The front roller of the feed-lattice h , Fig. 13, is driven by means of a side shaft and suitable gearing from the first doffer. The back roller is driven by means of a sprocket h_1 that is connected by a chain to a similar sprocket on the front roller shaft. By connecting the two roller shafts in this manner, the motion of the feed-lattice is made more positive. The carriage g and all its parts are driven by means of the pulley g_1 , which receives its motion by a belt from a pulley on the first cylinder shaft. The pulley g_1 carries a pinion g_2 which gears into the wheel g_3 on the shaft g_4 , the pinion g_2 being a change wheel. On the shaft g_4 is a bevel wheel g_5 which drives a bevel wheel g_6 attached to a sprocket wheel g_7 that by means of a chain gives motion to a similar sprocket wheel g_8 . A stud g_9 , fastened to the chain, engages a slot g_{10} in the carriage g ; the latter is therefore compelled to move alternately from one side to another as the stud moves round with the chain.

35. Driving Feed-Rollers on Carriage.—The rollers f, f_1 , Fig. 13, which feed the sliver to the lattice, are driven by a pulley f_2 on the shaft g_4 ; this pulley gives motion to the pulley f_3 on the shaft f_4 by means of a belt, as shown in Fig. 13 (*a*). A keyway on this shaft drives the wheel f_5 , the wheel being allowed to move along the shaft with the carriage g to which it is connected in any suitable manner, as indicated by the dotted square casing. The wheel f_5 drives a wheel f_6 which is fastened to a bevel wheel that gives motion to another one on the lower end of the shaft f_7 . At the upper end of this shaft there is a pair of bevel wheels f_8 that drives the spur wheel f_9 , Fig. 13 (*b*), the gear-wheel f_9 driving a wheel f_{10} at the end of the roller f , while f_{10} is meshing into a wheel f_{11} at the end of the roller f_1 . The wheels are mounted in a square frame which also carries a guard for the rollers f, f_1 , as indicated by the dotted lines. The carriage g is provided with a bush o_1 that slides on the thick rod o , Fig. 13 (*a*).

In some machines the carriage is mounted on wheels which run on a rail, as in Fig. 11.

36. Patting Board.—A patting board n , Fig. 13 (*a*), also shown in Fig. 11, is used for compressing and flattening down the sliver on the lattice h . The board receives its motion from a band pulley n_2 driven by a pulley on the first stripper shaft by means of a band n_1 . A crankpin n_3 on the pulley n_2 drives through a connecting-rod the crank n_4 on the shaft of the board n and gives it an oscillating motion.

APPERLEY FEED

37. Principal Features.—The Apperley feed is an intermediate feed that is usually attached to the carder, and in some cases between the scribbler and the intermediate. Its distinctive feature is that it lays the sliver diagonally across the feed-lattice. By reason of a certain tension to which it exposes the sliver, it is not suitable for short-fibred material. As seen from Fig. 15, it is somewhat similar to the Scotch feed in its general construction. The illustration shows a carder being fed continuously from the scribbler, a pair of overhead carrier rollers transferring the sliver from one machine to the other.

38. Laying of Sliver.—Fig. 16 is a plan view of the feeding device, which shows that the sliver is folded back on itself so as to form a number of parallel folds, called *doublings*. In Fig. 16 portions of the doublings have been omitted for the purpose of showing the supporting aprons. Fig. 17 is a front elevation showing the mechanism for placing the sliver on the feed-aprons. The material, as it is taken from the doffer by the doffing comb, is twisted by being passed through a rotating tube; this gives the sliver sufficient strength to be carried to the feeding device of the next machine. The sliver, as shown in Fig. 17, is passed between two rollers m , supported by a carrier y that slides on a rod t extending diagonally across the machine. As the carrier y travels from side to side, the sliver is laid on a series of revolving aprons p , made of woven cotton. Two latches r , Fig. 17, are lifted by the carrier each time that it reaches the side of the machine, and then they fall back in the loop formed by the sliver,

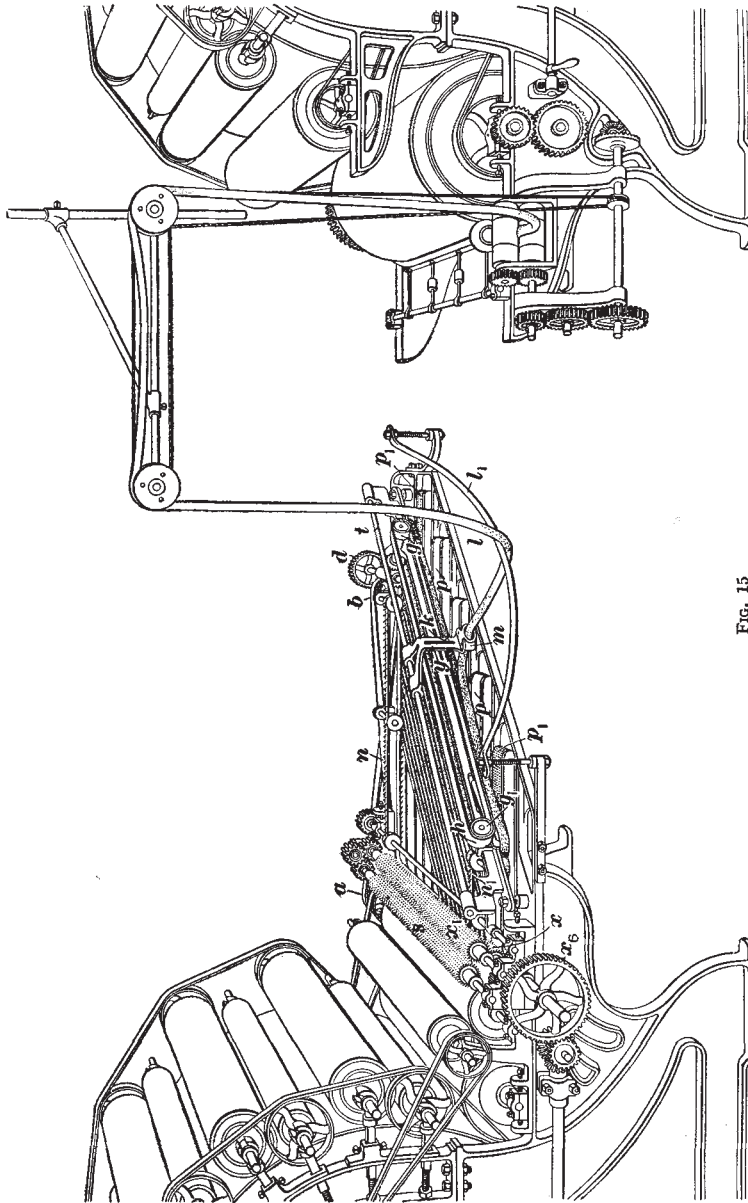

FIG. 15

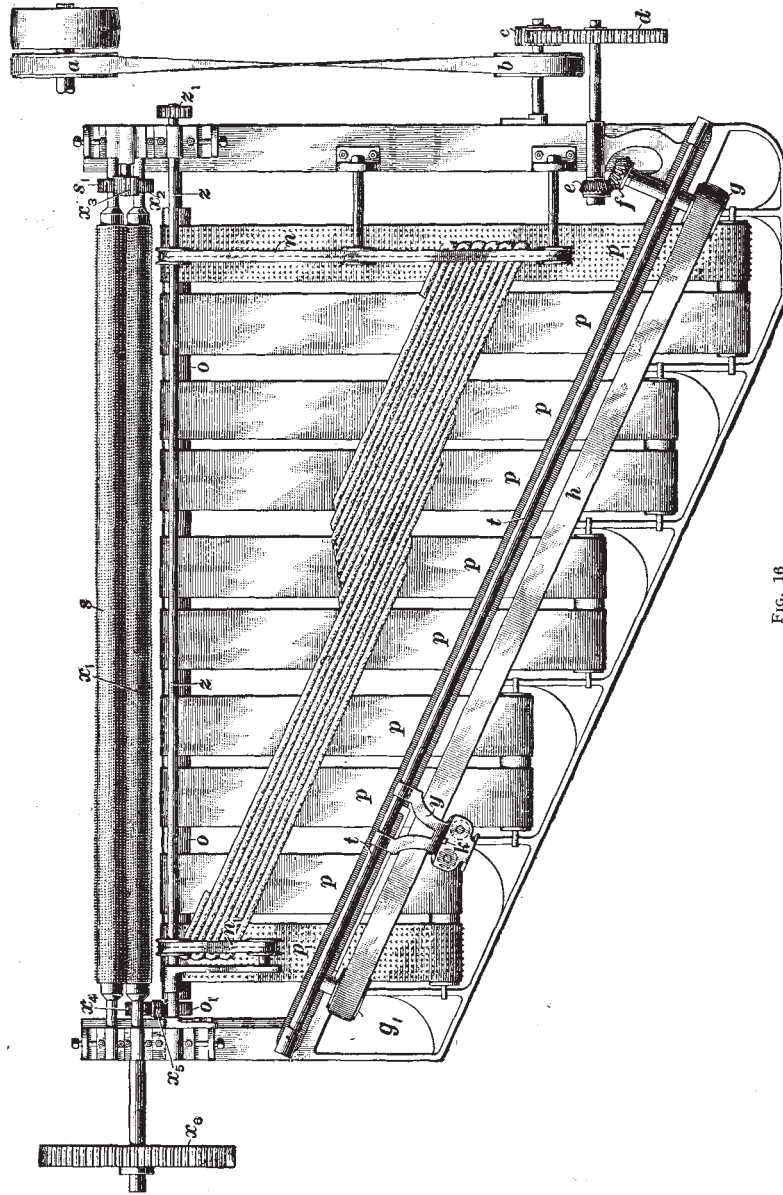

FIG. 16

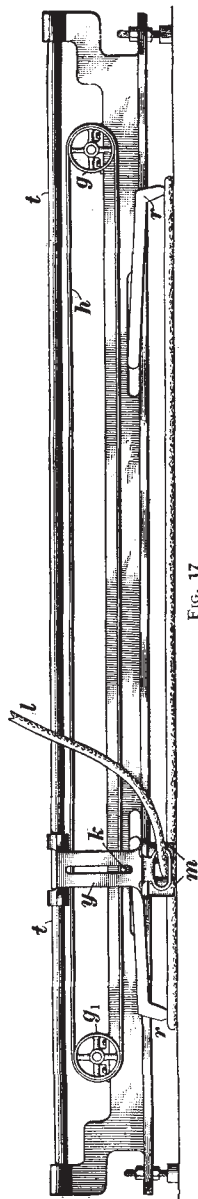

FIG. 17

thus holding it from drawing back as the next layer is placed on the aprons. The outside carrying aprons p_1 are called *retention bands* and are studded with short wires projecting through the apron a distance sufficient to prevent the sliver from drawing back. In addition, as the successive doublings are carried forwards by the carrying aprons p , they are taken by spiked straps n, n_1 , Fig. 16, which hold the slivers and do not allow them to contract after being released by the latches r . The spiked straps are filled with short wires about $\frac{1}{2}$ inch in length and travel in the same direction and at the same speed as the carrying aprons. The doublings are carried forwards to a pair of feed-rollers x, x_1 , Fig. 15, which deliver them to the licker-in of the carder.

The stripping roller s keeps the doublings from winding round the top feed-roller x_1 by stripping the doublings from it and delivering them to the licker-in. The feed-rollers and stripping roller are a part of the feeding machine instead of being a part of the carding machine, as in other instances.

39. Driving Carrying Aprons and Feed-Rollers.—The large gear-wheel x_6 , fastened to the bottom feed-roller shaft, Fig. 15, is driven from the side shaft of the carder. On the same shaft, but inside the framing, is a gear-wheel x_4 , Fig. 16, which drives an intermediate gear-wheel x_5 , which in turn imparts motion to a gear-wheel o_1 that is fast to the shaft of the front apron roller o . By this means motion is imparted to all the carrying aprons p and to the retention bands p_1 . The spiked straps n, n_1 are driven by grooved

pulleys on a shaft z that receives motion from a wheel on the shaft of the roller o that drives a wheel z_1 on the shaft z . The top feed-roller x_1 is driven by a wheel fastened to the shaft of the bottom feed-roller that drives the wheel x_2 fast to the shaft of the top feed-roller. The wheel x_2 also drives an intermediate x_3 , which drives a wheel s_1 on the shaft of the stripping roller s .

40. Driving Carrying Device.—The driving of the carrying device for placing the sliver on the carrying aprons is as follows: A pulley a , Fig. 16, on the licker-in shaft of the carder drives a pulley b by means of a crossed belt; attached to the same shaft as the pulley b is a wheel c that drives a gear-wheel d on a shaft on the other end of which is a bevel wheel e driving a bevel wheel f . On the same shaft as the bevel wheel f is a pulley g that drives a belt h , which also passes over a pulley g_1 at the other side of the feed. Attached to this belt is a projecting finger, or dog, k , also shown in Fig. 17, working in a slot of the carrier y , which slides easily on the rod l . The belt gives the carrier a reciprocating motion and the sliver l is passed between the rollers m and laid on the feed-apron as the carrier moves backwards and forwards. A guide rod l_1 , Fig. 15, is sometimes used to guide the sliver l ; it is made in a curved shape so as to keep the tension on the sliver the same, whether the carrier is in the centre of its traverse or at one side.

41. Adjustment of Feeding.—In using the Apperley feed, it is very important that the speed of the carrying aprons shall be so regulated that the sliver will be laid evenly and uniformly on them. If the aprons travel too slowly, the doublings will be crowded and will ride over each other, but if the speed is too fast, the feed to the carder will be too light and rapid. In case the doublings are crowded, the fault may be remedied by placing a larger gear-wheel on the doffer shaft, which will drive the feed-rollers and aprons faster. A smaller wheel on the doffer shaft will have the opposite effect and will make the doublings lie closer. It must be remembered that this change does not alter the amount of material fed to the carder or the weight or count of the rovings, but simply makes the feed lighter and more rapid or slower and heavier, according to whether a larger or smaller

wheel is used ; the same amount of material is in either case fed to the carder in a given time from the scribbler or the intermediate. Sometimes the feed will not keep up to the scribbler or intermediate, but will allow the sliver to lie in coils on the floor. This is usually due to the slipping of the belt on the carder and may be remedied by shortening the belt. Any great difference may be remedied by changing the speed of the carrier.

LAP FEEDS

42. Old Form of Lap Feed.—One of the oldest methods of conveying the web from one carding machine to another was to wind the web, as delivered by the doffer, on a large roller until the required number of layers had been wound on it. The length of web wound on it is called a *lap*. Fig. 18 is an example of this type of feed, the web *a* being removed from the doffer *b* by the doffing comb *c*, then, after passing under the roller *d*, it is wound

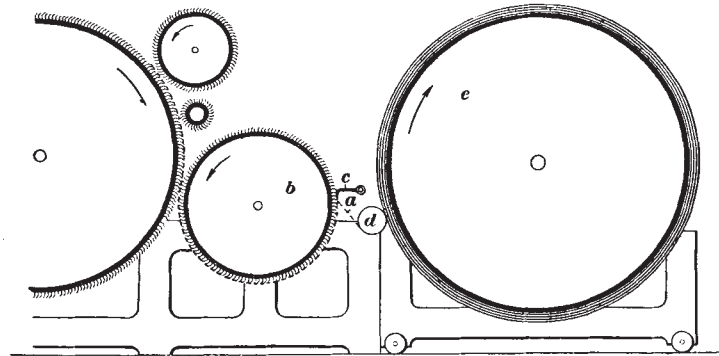

FIG. 18

on the roller *e*, known as the *lap roller*, usually 60 inches in circumference. When this roller has made a definite number of revolutions, a bell will be rung automatically ; the attendant then breaks the web. The lap roller is provided with an automatic device that cuts the lap in a direction parallel to the axis of the roller. When thus cut, the lap will consist of a number of layers of rectangular sheets of web, the lengths of which correspond to the width of the feed-lattice of the next machine on which this lap is now laid.

43. **Blamire Feed.**—In the Blamire feed, which is also known as the batt, or blanket, feed, the lap is formed in a manner that differs from that shown in Fig. 18. In the Blamire feed, which is shown in perspective in Fig. 19 (a), the web, after it leaves the doffer *a*, falls on to the lattice *b*, which has the same surface speed as

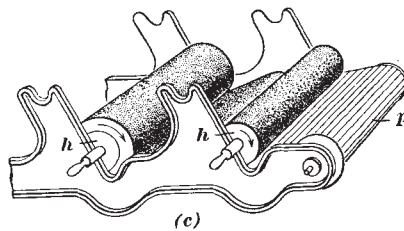
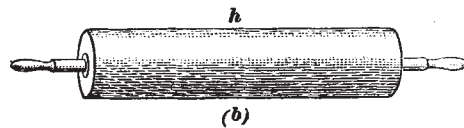
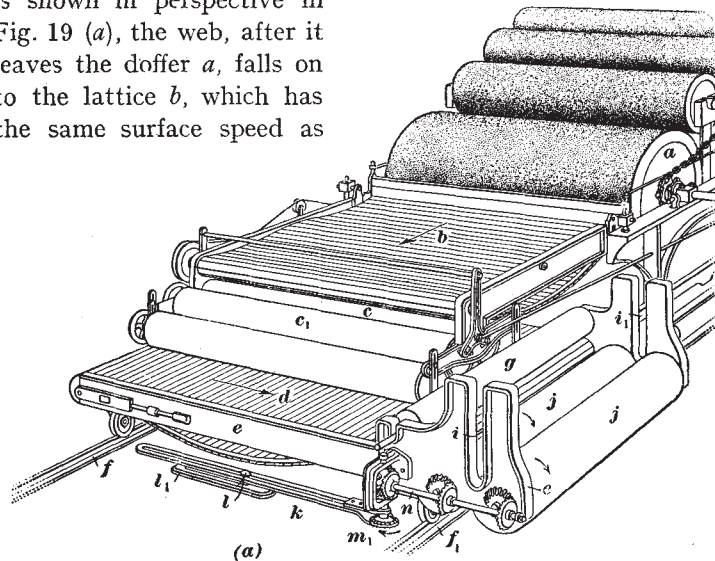

FIG. 19

that of the doffer. The web is carried by the lattice to the tin rollers *c*, *c*₁ and is by them deposited on to the lower lattice *d* which travels slowly in a direction at right angles to the lattice *b*. In addition to this motion the lower lattice also moves sideways, being mounted in a carriage *e* which runs on the rails *f*, *f*₁; the distance through which the carriage moves is equal to the width of the next machine to be fed. By reason of the to-and-fro motion of the carriage the web is

deposited in layers producing a lap that contains a certain number of doublings, the number depending on the speed at which the lattice d moves crosswise of the machine. Supposing that this motion is 3 inches for each outward or inward motion of the carriage, and that the machine is 66 inches wide, there will be $66 \div 3 = 22$ doublings in a lap 66 inches long, considering the length measured in the direction of the arrow on the lattice d .

44. Motion may be given to the lattice d , Fig. 19 (a), in a sidewise direction by various means; in this case the feed-lattice is driven by the lever k , a stationary stud l , fastened to a floor plate l_1 , projecting through a slot in the lever. The latter swings round a vertical shaft which has at its lower end a ratchet wheel m_1 ; two pawls attached to the lever k , one above and one below m_1 , engage the latter. When the carriage moves outwards, the lower pawl will compel the wheel m_1 with its shaft to turn in the direction of the arrow and the shaft n will therefore turn in the direction indicated, being driven by a pair of bevel wheels in the manner shown. Other bevel wheels on the shaft n engage with the bevel wheels on the shafts of the rollers j, j , which will revolve in the directions of the arrows. When the carriage performs its return motion the lever k will swing in an opposite direction, but as in this case a pawl on the upper side of m_1 will come into action, the latter will continue to revolve in the direction of the arrow. The angle through which the lever k will swing may be regulated by adjusting the position of the stud l in the plate l_1 ; if moved to the left the angular motion of k will be less. The lap, formed on the lattice d , passes under the heavy press roller g on to a *lap stick* h , Fig. 19 (b). This stick rests on the rollers j, j , which revolve it by frictional contact, the shaft of the stick projecting through the slots i, i_1 so as to hold it in position. When the lap, as wound on the roller, has attained a diameter of about 2 feet, the lap is broken off, the stick and lap removed and an empty one inserted in its place.

45. When two of the lap sticks h , Fig. 19 (b), are filled, they are laid on the feed-lattice p , Fig. 19 (c), of the next machine, which is usually the carder, as an intermediate is seldom used for

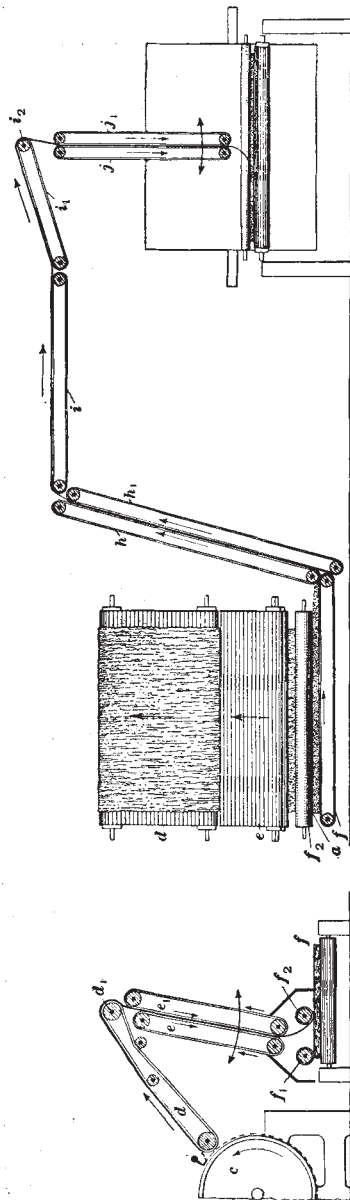

FIG. 20

carding the materials most suitable for the Blamire feed. As the laps from two rollers are fed to the machine, it is preferable to arrange the laps in the manner shown in the illustration, and to have one of them full while the other is half full. When the latter is empty and is replaced by a full one, the joint of the two laps will be less objectionable than if both rollers should be empty at the same time and the joints of both laps should coincide.

46. Josephy Feed.—The Josephy feed, Fig. 20, is an example of a Continental type of feed, used in connection with a Continental set of carding machines that are also used in British mills. View (a) represents a diagrammatic, longitudinal section of the machine, and view (b) a cross-section. The web, when removed by the doffing comb from the doffer *c*, is carried upwards by the lattice *d* and delivered to the lattices *e*, *e*₁, which are supported in a frame swinging round the roller shaft *d*₁. The swing lattices oscillate across the lattice *f* while delivering the web, and the

latter will therefore form a lap which in general is 16 to 20 inches wide. The rollers f_1, f_2 are supported by the frame of the swing lattice and compress the lap while rolling over it. The lattice f , as seen in view (b), conveys the lap a to the inclined lattices h, h_1 which deliver it by means of the conveyer lattices i, i_1 to the swing lattices j, j_1 . The latter, while swinging round the shaft i_2 , deliver the material to the feed-lattice of the intermediate, where it is formed into a lap extending the full width of the machine and conveyed to the feed-rollers in the usual manner.

BALL AND CREEL FEED

47. Principle of Operation.—In the ball and creel feed, sometimes called the ball and bank feed, the web of fibres is taken from the doffer by the doffing comb and formed into a rope, or sliver, by being passed through a revolving funnel; this funnel also gives the sliver a slight twist, so as to provide it with sufficient strength to reach the balling machine. The *balling machine* is that part of the ball and creel feed where the sliver is formed into balls; after a sufficient number of these balls are produced, they are transferred to another part called the *creel*. In the latter machine the balls are arranged in a number of rows for the purpose of unwinding them and passing their ends jointly through the feed-rollers of the intermediate or the carder.

48. Platt Balling Machine.—The Platt balling machine winds the sliver on to an empty bobbin, removes this, when full, and breaks the sliver. An empty bobbin is then moved into the position occupied by the full one, and the loose end of the sliver is automatically guided to the empty bobbin for the purpose of being wound on it. Fig. 21 is a perspective view of the machine, and Figs. 22 (a) and (b) a sectional view and a front elevation, respectively. In these views similar letters refer to similar parts. At c is shown an empty bobbin on which the sliver a is beginning to be wound. Above it, at c_1 , is a full bobbin, which may be removed by pulling out the rod c_2 . The side plates c_3 , which serve to make the sides of the ball even, remain in place, being held by bushes supported by the wheels n, n_1 . As the sliver a ,

Fig. 22 (a), comes from the last doffer of the scribbler, it is guided to the bobbin *c* by the rollers *b*₁, *b*₂, *b*₃, and the spout *b*, formed at the end of the arm *b*₄, which is pivoted at *b*₅. For the purpose

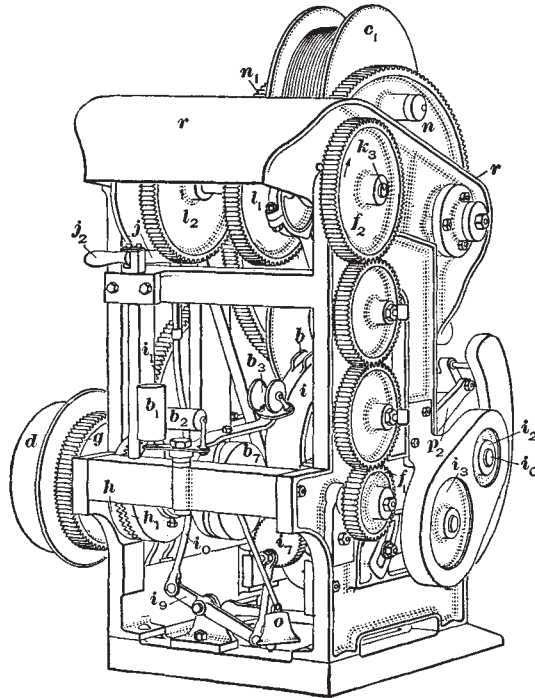

FIG. 21

of winding the sliver in layers, the arm *b*₄ is given a traversing motion of about $3\frac{1}{2}$ to 4 inches by means of a pin *b*₆, which rests in a curved groove formed in the drum *i*₇.

49. The bobbin *c*, Fig. 22, is revolved by frictional contact with the bobbin drum *i*; on the shaft *i*₀ of this drum there is a wheel *i*₁ driven by the pinion *g* on the sleeve of the pulley *d*. The latter is driven by a belt from a pulley on the shaft of the side drawing-off roller on the scribbler. The shaft *f*, on which the pulley *d* and wheel *g* revolve loosely, extends across the machine and carries at its right-hand end a pinion *f*₁ which by

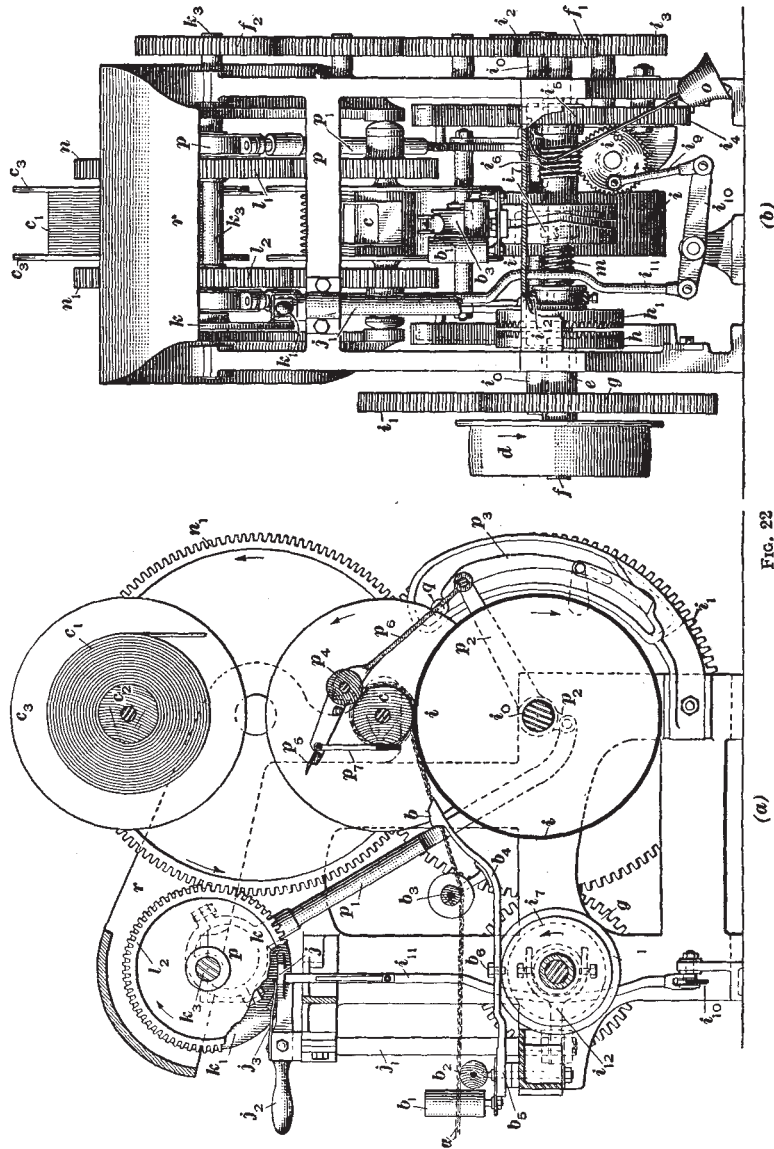

FIG. 22

means of a series of wheels drives the gear-wheel f_2 keyed to the top shaft k_3 . At the left-hand end of the shaft f , Fig. 22 (b), there is fastened to the sleeve of pulley b one half h of a coupling; the other half h_1 is connected by a keyway to the shaft, in such a manner that it may move sidewise. A spiral spring m tends constantly to move the part h_1 into mesh with h , but is prevented from doing so by means of a device that will be described farther on.

50. At the other end of the drum shaft i_0 , Figs. 21 and 22 (b), there is a pinion i_2 that drives the wheel i_3 which is attached to a short shaft; this shaft extends through the side frame of the machine and carries at its other end a pinion that by means of a carrier i_4 gives motion to a wheel i_5 . The latter drives the loose worm i_6 and the cam-drum i_7 , fastened to it; it follows that the bobbin drum i , worm i_6 , cam-drum i_7 , and the coupling half h are constantly revolving, being driven indirectly by the pulley d , while the shaft f and the other parts of the machine are at rest.

51. The means by which the shafts f and k_3 , Fig. 22, are periodically set in motion will now be explained. The worm i_6

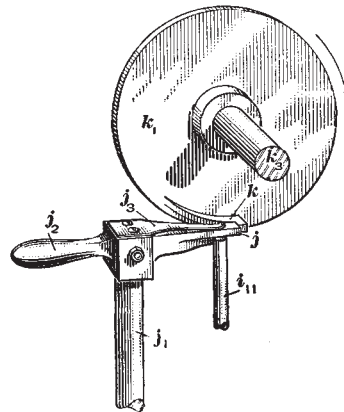

FIG. 23

causes the worm-wheel i_8 to revolve in the direction of the arrow; the connecting-rod i_9 , attached at one end to a crank-pin on i_8 and by the other end to the rocking lever i_{10} , will move the latter so as to lift the rod i_{11} fastened to its other end. As seen from Fig. 22 (a), and more clearly from the detail view, Fig. 23, the upper end of the rod i_{11} will engage a finger j which is pivoted to the upper end of the shaft j_1 . As the worm-wheel i_8 continues its revolution, the rod i_{11} will eventually lift the finger j free from the projection k on the disc k_1 , which is fastened to the shaft k_3 . The lower end of the shaft j_1 is fastened to a fork i_{12} resting in a groove

in the coupling half h_1 ; therefore, when the finger j is free from the projection k , the shaft j_1 is free, and the spring m on shaft f will be able to push the coupling h_1 into mesh with the coupling h , thus compelling the shaft f to revolve. The shaft k_3 , driven by means of the wheels f_1, f_2 , and intermediate carriers, will likewise be set in motion. On the latter shaft there are two pinions l_1, l_2 that mesh with the wheels n, n_1 and revolve them in the direction of the arrow, Fig. 22 (*a*); the ratio between the diameters of l_1 and n is 1 : 2, hence n will make one-half of a revolution for each revolution of l_1 .

52. As soon as the finger j , Figs. 22 and 23, is free from the projection k , the spring j_3 will move it downwards into its former position, the rod i_{11} being out of its path. When, therefore, the disc k_1 has made one revolution, the projection k will be caught by the finger j and the shafts k_3 and f will cease revolving. As the finger j slides along the inclined portion of k it will be moved outwards, thereby turning the shaft p_1 so as to disengage the portion h_1 from h in the coupling. The wheels n, n_1 having made one-half of a revolution, the filled bobbin c will have moved into the position of the bobbin c_1 , where previously an empty bobbin has been inserted, which now occupies the position of bobbin c . As the worm-wheel i_8 continues its revolution, an extension of its crankpin will eventually meet a projection on the spring supporting the bell o . After moving this spring a short distance to the left, it will be released and cause the bell to ring, thus notifying the attendant that the empty bobbin is being filled and that the full bobbin must be replaced by an empty one.

53. While the bobbin c , Fig. 22 (*a*), is being filled, the roller p_4 with the lever p_6 will gradually move toward the right and a small roller q fastened to the lever p_6 will move into a position on top of the inclined portion of the projection p_3 , formed on an extending arm of the frame. When the shaft k_3 performs one revolution the eccentric p will, by means of the connecting-rod p_1 , rotate the lever p_2 , which is loosely pivoted on the shaft i_6 , so that its outer end will move downwards. The roller q in contact with the projection p_3 will swing the arm p_6 outwards and out of reach of the ascending full bobbin. As the shaft k_3 completes its

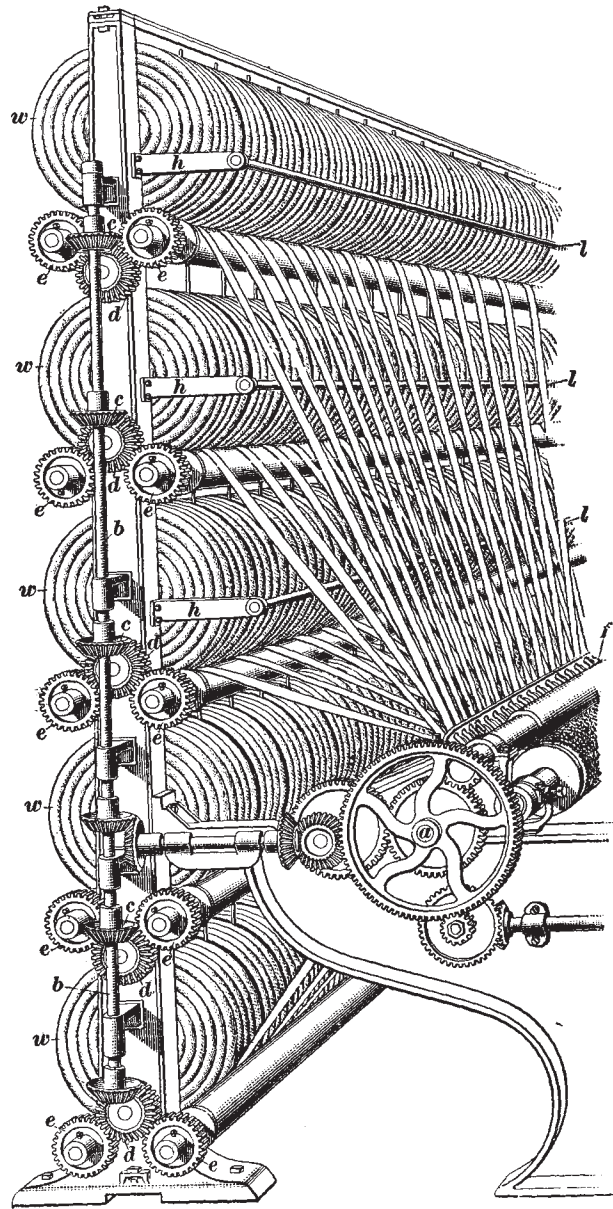

FIG. 24

revolution the lever p_6 will return to its former position, and while doing so the fork p_5 will break the sliver which now runs from under the bobbin c up to the full bobbin c_1 . While the apron p_7 slides over the broken end of the sliver, the latter will be guided round the bobbin until it finally reaches the lower side and is wound on to the bobbin. The eccentric p , connecting-rod p_1 , and levers p_2 are in duplicate. To allow for the upward motion of the bobbin c , in conformity with its increase in diameter, the shafts of the wheels n , n_1 are supported in a movable frame r pivoted on the shaft k_3 . The size of the ball is determined by the change wheel i_2 ; when the latter is large the worm-wheel i_3 will revolve faster and the finger j will be sooner released, thus the bobbin will be sooner removed and be of a smaller size. The winding of a ball may at any time be stopped by raising the lever j by means of the handle j_2 ; the bobbin will then be moved out of contact with the drum i and into the upper position, and an empty one will take its place.

54. **Creel.**—The balls of wool that are prepared by the balling machine just described are placed in a creel at the rear of the intermediate carding machine. The **creel**, or **bank** as it is often termed, which is shown in Fig. 24 in perspective, consists of five sets of rollers on which the balls of material are resting. It is generally known as a **five-bank creel**; four-bank creels are also used; but whether a four-bank or a five-bank creel is adopted, it should be capable of containing from 60 to 90 balls, the ends of which are to be fed to the intermediate. The rollers are given a rotating motion and the balls w , resting on them, are thus unwound, the slivers of wool being delivered to the feed-rollers of the intermediate after passing through a perforated steel guide plate f , the details of which are shown in Fig. 25.

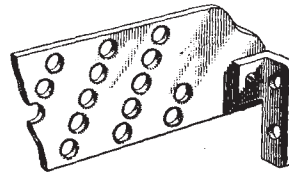

FIG. 25

55. The creel consists of two vertical stands that carry the bearings for the rotating rollers, on which the balls rest; the rollers are driven, as shown in Fig. 24, from the feed-roller shaft a of the intermediate. Motion is imparted to an upright shaft b at

one end of the creel by means of a pair of bevel wheels. This upright shaft carries bevel wheels *c* that impart motion to the sets of rollers, on which the balls rest, by means of intermediates *d* and the wheels marked *e* on the ends of the rollers. The balls are separated from one another by means of iron rods passing from the top to the bottom of the creel between the rollers, as shown in Fig. 24. On each side of the creel at the ends of the three top banks, brackets *h* support iron rods *l* passing across the creel in front of the balls; these prevent the balls from being thrown out of the creel and falling into the carding machine.

OPENING AND BURRING

PURPOSE AND METHODS

OPENING ARRANGEMENTS

56. Modified Licker-In and Breast Cylinder.—There are many arrangements of special opening rollers that may be employed to advantage in woollen-carding machines; their object is to preserve the length of the staple of the material, to keep the wire of the card clothing in better condition, and to produce a more nearly perfect roving. In one arrangement the licker-in is made to perform the function of a cylinder by increasing its diameter sufficiently to accommodate 2 or even 3 pairs of workers and strippers over it. It is, however, still capable of being satisfactorily stripped by the angle stripper which passes the material to the first cylinder. A better arrangement is to reduce the size and speed of the first cylinder; thus, its diameter might be 44 inches and it may revolve at a speed of from 50 to 60 revolutions per minute. Over it may be placed 3 pairs of workers and strippers with fancy and doffer. Being reduced in size its surface speed may be about one-half that of the full-sized cylinder, and consequently its carding action will be correspondingly milder, which results in less breakage of fibre and in less waste under the first doffer.

57. **Tumbler.**—A feeding arrangement that is a great improvement on the ordinary method of feeding the carder is shown in Fig. 26, and consists of the feed-lattice *a* and the feed-rollers *b*; as in the ordinary arrangement, the feed-rollers deliver the material to a licker-in *c*, which is 6 or 7 inches in diameter and revolves point first in the direction of the arrow. The licker-in is stripped by the roller *d*, known as a *tumbler*, or *tummer*, which is 12 or 14 inches in diameter and revolves point first in the direction indicated. The material from the licker-in is therefore taken in a downward direction by the tumbler, and to prevent a large amount of it from being thrown on to

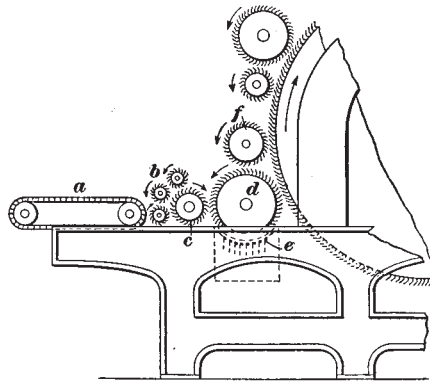

FIG. 26

the floor a grid *e* with a cage is employed which collects a large amount of dirt freed from the material by the action of the tumbler. A small worker *f*, 7 inches in diameter, is stripped by the tumbler. The material, after passing the worker *f*, is carried to the first pair of workers and strippers by the cylinder and through the machine in the ordinary way. This arrangement is very efficient and is rapidly displacing the licker-in and angle-stripper method of feeding, particularly on the carder.

58. **Metallic Breast.**—Occasionally, when hard work is done, a metallic, or **Garnett, breast** is used in connection with the first breaker. This operates on the same principle as the first cylinder of the scribbler, but owing to its slower speed is more gentle in its action and gradually opens the wool, so that few fibres are broken when taken by the swiftly revolving cylinder.

The metallic breast shown in Fig. 27 consists of two metallic feed-rollers *a*, *a*₁ which take the material and pass it to a licker-in *b*, which is covered with Garnett wire and passes the wool to the metallic breast *d*. A small stripper *a*₂ keeps the bottom

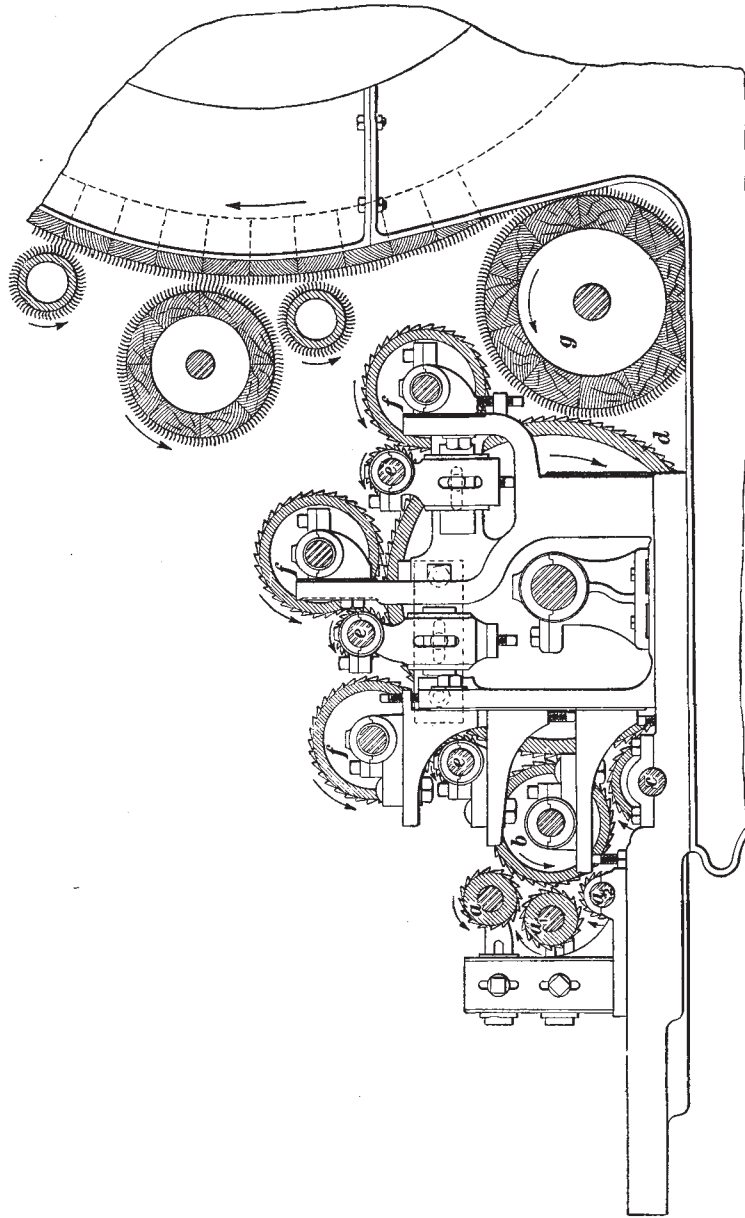

FIG. 27

feed-roller clear, while a roller *c*, called the *breast roller*, cards the wool on the licker-in *b* and delivers such as is not retained by the licker-in to the breast, which is 16 inches in diameter and works in connection with three 6-inch workers *f* and three $2\frac{1}{4}$ -inch strippers *e* in the same manner as the cylinder works with the ordinary workers and strippers. The wool is then taken by the tumbler *g* and passed to the cylinder. A breast cylinder should run at about $\frac{1}{4}$ to $\frac{1}{2}$ the surface speed of a full-sized cylinder.

BURRING ATTACHMENTS

59. General Purpose.—When the burrs, embedded in the wool, are not so numerous as to require its being passed through a separate burring machine, it will suffice to attach a combination of opening and burring rollers at the feed end of the scribbler. The object of such devices is not only to remove the foreign matter in dirty wool, but also to open out any snarls or bunches and not allow them to pass forwards to strain the card clothing. On certain classes of wool, burr rollers are a benefit, especially for very fine wools, which tend to cling together in small lumps and bunches. Devices of this kind are never attached to the intermediate, nor to the carder, as after the wool has passed through one carding process the burrs are broken up.

60. Double Burring Attachment.—An arrangement of two burr rollers, often applied to scribblers when carding all-wool materials, is shown in section in Fig. 28. It consists of a pair of steel-ring feed-rollers *a* and *a*₁, two steel-ring burr rollers *b*, *c*, and two burr beaters *b*₁, *c*₁ with thirteen blades each; these parts are supported by a frame carrying the necessary bearings which is readily bolted to the end of the scribbler frame.

In operation, the wool is taken by the feed-rollers and passed to the first burr roller, which, in connection with the burr beater *b*₁, frees it from burrs and dirt that have not been removed in the previous operations. The wool then passes to the second burr roller *c*, which, as its adjoining side is running upwards, receives on its surface the side of the wool already cleaned, completely turning over the lock of wool and presenting to the beater *c*₁ all

burrs, etc., that are on the side not cleaned. The wool passes from the burr cylinder c to the tumbler of the scribbler. The burr beater c_1 throws the burrs into a burr pan placed over the burr cylinders and the beater b_1 throws burrs and other refuse on the floor under the machine. The top feed-roller a is stripped and kept clear by the burr cylinder b , which combs the wool

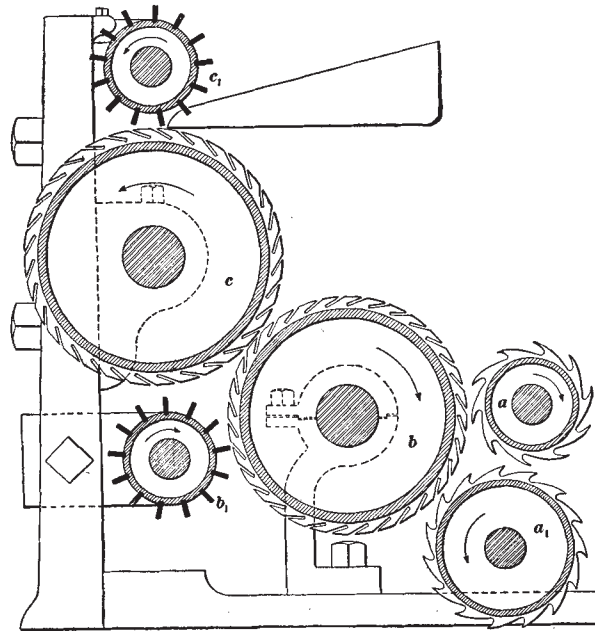

FIG. 23

through the teeth of the lower feed-roller a_1 and removes a large amount of burr matter which is dropped under the machine. A wipe or stripper roller is sometimes necessary for keeping the bottom feed-roller clean. Very often, however, a single burr roller with burr beater is sufficient for removing the burrs before the material passes to the tumbler.

61. A form of double burring attachment that contains burr rollers of slightly different diameters is shown in Fig. 29. In the operation of this machine the wool is taken by a pair of feed-rollers a, a_1 and delivered to the first burr roller b , which strips

the lower feed roller *a*, while the top roller *a*₁ is kept clear by a stripper *a*₂. The burr rollers are similar to those in the previous machine, the burrs being removed by two burr beaters *b*₁, *c*₁ that

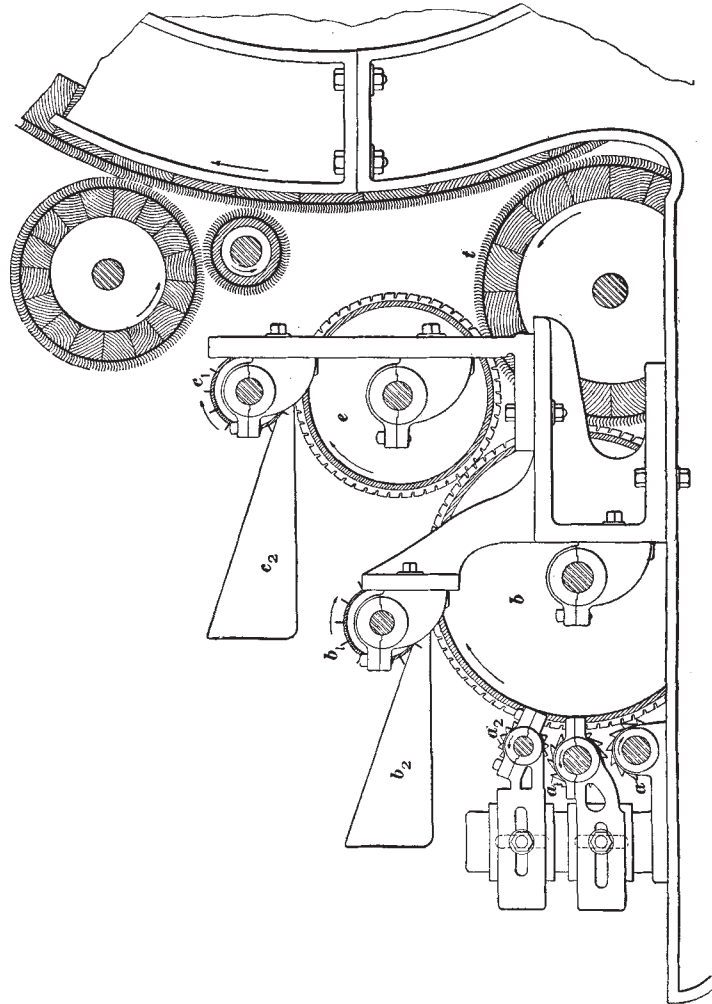

FIG. 29

knock them into the pans *b*₂, *c*₂. The tumbler *t* takes the wool from both burr rollers and passes it to the cylinder of the scribbler.

TYPICAL SETS OF CARDING MACHINES

COMPOSITION AND DETAILS

BRITISH SETS

62. Factors Governing Composition of Sets.—The composition of sets of carding machines varies considerably, being influenced very largely by the kind of material to be carded and by the opinion of the carding engineer. The following may be taken as typical sets : For the medium-class woollen trade, such as that in tweed and cheviot yarns, two machines are favoured, one of which consists of a scribbler with a breast and two cylinders, and the other of a carder, with two cylinders, fed by a Scotch feed. If a set of three machines is adopted, which has the advantage of ensuring a more thorough mixing of the fibres, and also affords the opportunity of introducing small quantities of bright colours, it might consist of a scribbler with a breast and two or three cylinders, an intermediate with one cylinder, and a carder with two cylinders. A ball feed is used to feed to the intermediate, and this allows of the introduction of small quantities of other colours. A Scotch feed is used to convey the sliver from the intermediate to the carder which is provided with a double-doffer tandem-rubber condenser. It will thus be seen that three machines in one set are used to regulate more accurately and also to obtain a better and more complete blending or mixing of the fibres. It should be noted, however, that sets composed of three machines are now seldom adopted.

63. To card blends of low mungo and cotton successfully, a long machine running at a slow speed must be used to open out the cotton satisfactorily and at the same time to cleanse the mungo of dirt. A set might be composed of a scribbler with

a breast and four cylinders, a Blamire feed and a carder with two cylinders, the condenser being of the double-doffer or tape class.

TABLE I
DETAILS OF SCRIBBLER FOR COARSE MATERIAL

Name of Roller	Number of Rollers	Diameter of Roller Inches	Card Clothing			
			Foundation	Count	Crown	Gauge No. of Wire
BREAST-CYLINDER PART :						
Feed-roller . . .	3	2½	Leather—fillet Fillet			12
Licker-in . . .	1	12				12
First angle strip- per	1	4	Fillet	40	4	20
Breast cylinder . .	1	48	Sheets	40	4	20
Worker	3	9	Sheets	40	4	20
Stripper	3	5	Fillet	40	4	20
Fancy	1	12	Sheets	40	4	19
Doffer	1	36	Sheets	40	4	20
FIRST-CYLINDER PART :						
Second angle						
stripper	1	5	Fillet	40	4	20.
First cylinder . . .	1	50	Sheets	70	7	25
Worker	3	9	Sheets	75	7	25
Stripper	3	5	Fillet	50	4	22
Fancy	1	13	Sheets	50	5	23
Doffer	1	36	Sheets	75	7	26
SECOND-CYLINDER PART :						
Third angle strip-						
per	1	5	Fillet	60	6	22
Second cylinder . .	1	50	Sheets	100	9	30
Worker	3	9	Sheets	105	9	30
Stripper.	3	5	Fillet	60	6	25
Fancy	1	13	Sheets	60	6	28
Doffer	1	36	Fillet	105	9	31

To card blends of wool for high-class woollen yarns a suitable set of machines would include a scribbler with a breast and two

cylinders and a carder with two cylinders, together with a Scotch feed to convey the sliver to the carder from the scribbler ; also a single ring doffer with tandem rubbers. An alternative set of machines, such as are used in the West of England, might be

TABLE II
DETAILS OF CARDER FOR COARSE MATERIAL

Name of Roller	Number of Rollers	Diameter of Roller Inches	Card Clothing			
			Foundation	Count	Crown	Gauge No. of Wire
BREAST-CYLINDER						
PART :						
Feed-roller . . .	3	2	Leather—fillet			14
Breast cylinder . .	1	30	Sheets	80	8	27
Worker	2	9	Sheets	85	8	27
Stripper	2	5	Fillet	60	6	25
FIRST-CYLINDER						
PART :						
First angle strip- per	1	5	Fillet	60	6	25
First cylinder . . .	1	50	Sheets	110	10	32
Worker	3	9	Sheets	115	10	32
Stripper	3	5	Fillet	80	8	28
Fancy	1	13	Sheets	60	6	29
Doffer	1	36	Sheets	115	10	32
SECOND-CYLINDER						
PART :						
Second angle stripper	1	5	Fillet	80	8	28
Second cylinder . .	1	50	Sheets	120	11	33
Worker	3	9	Sheets	125	11	33
Stripper	3	5	Fillet	80	8	29
Fancy	1	13	Sheets	70	7	30
Ring doffer	2	20	Rings—fillet	115	10	31

composed of a scribbler with a breast and two cylinders, an intermediate with one cylinder, and a carder with one cylinder, the Scotch feed being applied to both intermediate and carder. The condenser would be the same as in the preceding case.

64. Sets of Carding Machines for Different Materials.—The number and respective diameters of the rollers, together with

TABLE III
DETAILS OF SCRIBBLER FOR MEDIUM MATERIAL

Name of Roller	Number of Rollers	Diameter of Roller Inches	Card Clothing			
			Foundation	Count	Crown	Gauge No. of Wire
BREAST-CYLINDER PART :						
Feed-roller . . .	3	$2\frac{1}{2}$	Leather—fillet			14
Licker-in . . .	1	9	Leather—fillet			14
First angle stripper	1	6	Fillet	50	4	22
Breast cylinder	1	$40\frac{1}{2}$	Sheets	70	7	26
Worker	3	9	Sheets	75	7	26
Stripper	3	4	Fillet	50	4	22
Fancy	1	12	Sheets	50	5	23
Doffer	1	30	Sheets	75	7	26
FIRST-CYLINDER PART :						
Second angle stripper	1	6	Fillet	50	4	22
First cylinder	1	50	Sheets	90	9	29
Worker	4	9	Sheets	95	9	29
Stripper	4	4	Fillet	60	6	26
Fancy	1	17	Sheets	55	6	27
Doffer	1	36	Sheets	100	9	30
SECOND-CYLINDER PART :						
Third angle stripper	1	6	Fillet	60	6	26
Second cylinder	1	50	Sheets	110	10	31
Worker	4	9	Sheets	115	10	32
Stripper	4	4	Fillet	70	6	28
Fancy	1	13	Sheets	60	6	29
Doffer	1	36	Fillet	115	10	32

particulars of the card clothing, for a set of machines that would perform good work on coarse materials, are given in Tables I

and II; in Tables III and IV are given corresponding details for a set of machines for medium materials; and in Tables V, VI, and VII, the details apply to a set of machines for carding fine materials for fine woollen and fancy-mixture yarns. In each table the various groups of rollers are designated as a *part* of the

TABLE IV
DETAILS OF CARDER FOR MEDIUM MATERIAL

Name of Roller	Number of Rollers	Diameter of Roller Inches	Card Clothing			
			Foundation	Count	Crown	Gauge No. of Wire
FIRST-CYLINDER						
PART :						
Feed-roller . . .	3	2½	Leather—fillet			16
Licker-in . . .	1	9	Leather—fillet			16
First angle stripper	1	6	Fillet	60	6	24
First cylinder . . .	1	50	Sheets	125	11	34
Worker	4	9	Sheets	130	11	34
Stripper	4	4	Fillet	80	8	28
Fancy	1	13	Sheets	70	7	31
Doffer	1	36	Sheets	130	11	34
SECOND-CYLINDER						
PART :						
Second angle stripper . . .	1	6	Fillet	80	8	28
Second cylinder . . .	1	50	Sheets	130	11	34
Worker	4	9	Sheets	130	11	34
Stripper	4	4	Fillet	80	8	29
Fancy	1	13	Sheets	75	7	33
Doffer	1	36	Fillet	130	12	34

set. At present the tendency is to increase the size of the doffer so that it will be from 40 to 50 inches in diameter.

In those parts of the tables that refer to the card clothing with which the rollers are covered, the terms *count* and *crown* are found. Referring to fillet clothing the *count* is the number of points counted in a length of 5 inches in any one of the rows that run lengthwise of the fillet and crosswise in the case of sheet clothing.

The *crown* is the number of heads, per inch, measured crosswise on fillet clothing and lengthwise on sheet clothing, a *head* being

TABLE V
DETAILS OF SCRIBBLER FOR FINE MATERIAL

Name of Roller	Number of Rollers	Diameter of Roller Inches	Card Clothing			
			Foundation	Count	Crown	Gauge No. of Wire
BREAST-CYLINDER						
PART :						
Feed-roller . . .	3	2	Leather—fillet			14
Licker-in . . .	1	12	Leather—fillet			14
First angle strip- per	1	4½	Fillet	50	4	22
Breast cylinder . . .	1	36	Sheets	70	7	26
Worker	2	9	Sheets	75	7	26
Stripper	2	4	Fillet	60	6	22
Fancy	1	11	Sheets	50	5	23
Doffer	1	24	Sheets	75	7	26
FIRST-CYLINDER						
PART :						
Second angle stripper	1	7	Fillet	50	4	22
First cylinder . . .	1	50	Sheets	100	9	31
Worker	4	8	Sheets	105	9	31
Stripper	4	4	Fillet	70	6	26
Fancy	1	13	Sheets	65	6	30
Doffer	1	36	Sheets	110	10	32
SECOND-CYLINDER						
PART :						
Third angle strip- per	1	7	Fillet	70	6	26
Second cylinder . . .	1	50	Sheets	120	11	33
Worker	4	8	Sheets	125	11	33
Stripper	4	4	Fillet	80	8	29
Fancy	1	13	Sheets	70	7	32
Doffer	1	36	Fillet	130	11	34

the connecting part of two teeth visible on the back side of the clothing. Feed-rollers and lickers-in may be covered with

TABLE VI
DETAILS OF INTERMEDIATE FOR FINE MATERIAL

Name of Roller	Number of Rollers	Diameter of Roller Inches	Card Clothing			
			Foundation	Count	Crown	Gauge No. of Wire
Feed-roller.	3	2	Leather—fillet			16
Licker-in	1	12	Leather—fillet			16
Angle stripper	1	7	Fillet	70	6	24
Cylinder	1	50	Sheets	125	11	34
Worker	4	8	Sheets	130	11	34
Stripper	4	4	Fillet	80	8	30
Fancy	1	13	Sheets	70	7	32
Doffer	1	36	Fillet	130	11	34

TABLE VII
DETAILS OF CARDER FOR FINE MATERIAL

Name of Roller	Number of Rollers	Diameter of Roller Inches	Card Clothing			
			Foundation	Count	Crown	Gauge No. of Wire
BREAST-CYLINDER PART :						
Feed-rollers	3	2	Leather—fillet			16
Licker-in	1	6	Leather—fillet			16
First angle stripper	1	5	Fillet	70	6	25
Breast cylinder	1	30	Sheets	110	10	32
Worker	2	8	Sheets	110	10	32
Stripper	4	4	Fillet	70	8	29
Second angle stripper	1	5	Fillet	80	6	29
FIRST-CYLINDER PART :						
First cylinder	1	50	Sheets	135	11	35
Worker	4	8	Sheets	135	11	35
Stripper	4	4	Fillet	80	8	31
Fancy	1	13	Sheets	75	7	33
Doffer	1	36	Fillet	130	12	35

Garnett wire or with clothing in which the points are set farther apart than those in regular clothing ; it is, therefore, not customary to indicate the fineness of this clothing in terms of crowns and counts. The subject of card clothing is fully explained in *Woollen Carding*, Part 3.

CONTINENTAL SYSTEM OF WOOLLEN CARDING

65. Composition of Set of Machines.—A set of Continental machines may consist of three distinct machines, that is, of scribbler, intermediate, and carder, each machine having one cylinder with five or six pairs of workers and strippers and two fancies and doffers. Or a set of machines may consist of a scribbler with a breast about 36 inches in diameter and one cylinder 50 inches in diameter, the carder having only one cylinder 50 inches in diameter. The machines are clothed throughout with fine fillet, that on the intermediate and carder being finer than that on the scribbler ; and the material is carefully prepared for carding, so that when it is fed to the scribbler it is in a soft and finely opened condition, and not liable to injure the wire by hard bits of material. When a breast part is adopted, it may consist of a breast cylinder with two or three pairs of workers and strippers, which may be clothed with ordinary fillet clothing or Garnett wire, a doffer and angle stripper conveying the material to the main cylinder with its five or six pairs of workers and strippers.

66. Construction of Carder.—The carder is similar to the intermediate, with the exception that the rollers are covered with finer card clothing. A carder of a Continental pattern is shown in Fig. 30, from which the general arrangement of the parts may be seen. The material is fed on the feed-lattice *a*, to the feed-rollers *b*, which feed the material to the licker-in *c* ; this roller revolves in a downward direction, as indicated by the arrow, carrying the material over the grid *d* to the cylinder *e*. The cylinder submits the material to the action of 5 pairs of workers and strippers *f* and *g*, respectively ; the workers are comparatively large and the strippers small, so as to obtain the maximum of carding surface and allow of an extra pair being placed over the cylinder.

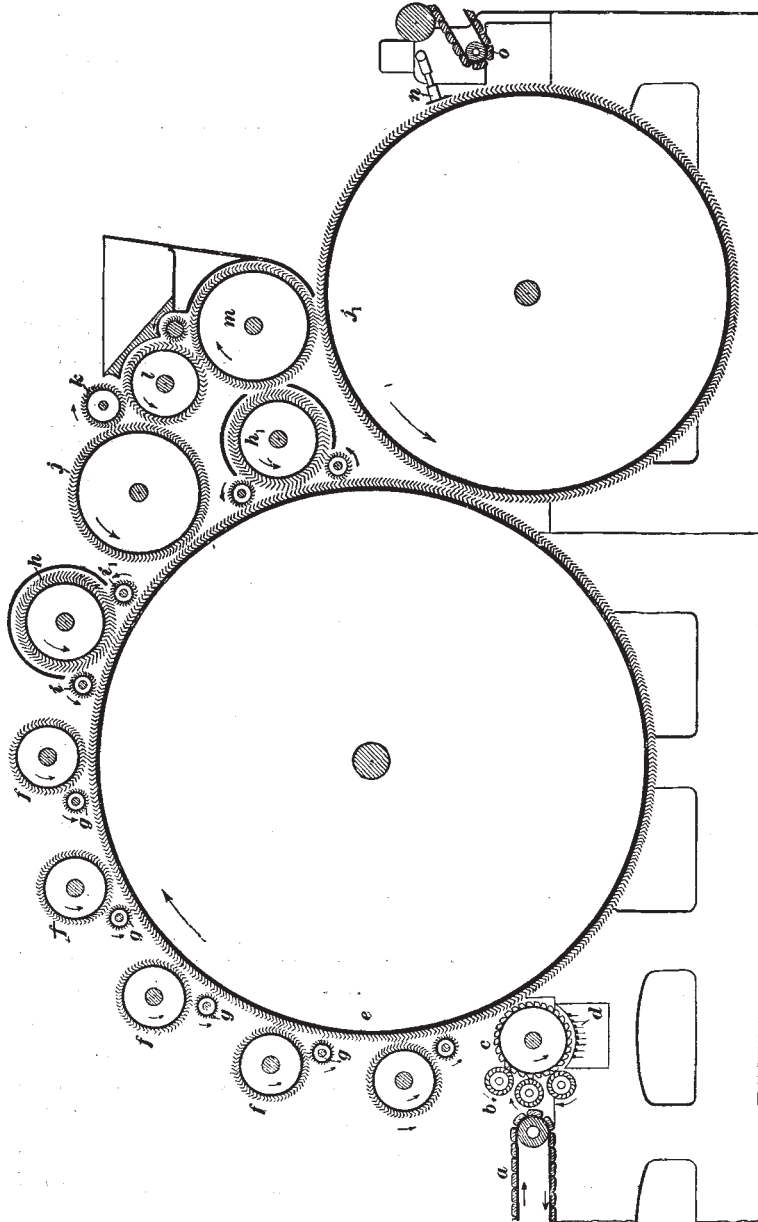

FIG. 30

67. The material is acted on by the fancy h , which revolves at a great speed and is usually covered in ; fly strippers i and i_1 are placed one at the back and one at the front of each fancy. After the material has passed the fancy it is deposited on the doffer j , which revolves in the opposite direction to that usually adopted and carries the material round till it engages with the dirt roller k , which clears it of any impurities. Both the doffer j and the dirt roller k are stripped by the stripper l , which is in turn stripped by the stripper m , which deposits the material on the lower and principal doffer j_1 . The material that is not removed by the top doffer j is carried round by the cylinder to the lower fancy h_1 , which, as it is set deeper into the cylinder than the upper one, raises the remaining material to the tips of the teeth, so that it is deposited on the lower doffer j_1 . This doffer is stripped by a doffing comb n , the material passing over a short lattice o to the dividing rollers of a 6-rubber tape condensing machine of the usual form.

CONTINENTAL SETS COMPARED WITH BRITISH

68. **Characteristics of Continental Sets.**—Continental sets of carding machines usually comprise three single-cylinder machines. The principal differences between British and Continental sets are that in Continental sets the fancies are covered in, the bends are close to the cylinders, and all the driving is outside the framing, while the contrary is the case with British machines. A little consideration will show that these characteristics of the Continental machines are in the direction of increasing the speed of the rollers and thus increasing the output, while at the same time a satisfactory roving is obtained. The effect of setting the bends close to the main cylinders and of covering the fancies is to reduce the draught caused by the revolution of the rollers and thus reduce the amount of fly to a minimum.

Another feature of Continental sets is that a tape condenser is always used, this giving a greater and, it is claimed, a more efficient production. Further, two doffers and two fancies are used where the maximum production is being obtained or where the machines are being forced. By this means the main cylinder

is kept cleaner, and consequently it is always in a fit condition to take the full amount of material it is possible to put through.

69. Comparison of Carding Surfaces.—Continental sets of machines have a more compact appearance than British sets and have more sets of workers and strippers over each cylinder. Then, also, the card clothing has a thicker foundation than that which is in general use on British machines and the wire is filled up to the bend with woollen felt or similar material. The carding surface thus obtained is firmer than that on a British set, but is less pliable and springy in character, and for that reason the rollers cannot be set into each other so as to maintain a good working point. It is claimed, however, that the firmer carding surface can be set closer and more accurately, and will thus do better work, but it is admitted that where, as in foreign sets, the rollers are not set into each other, grinding must be done much more frequently, and that a ground point is never so effective as one obtained by having the rollers work into each other.

70. Production of British and Continental Sets.—The amount of work turned off by any set of carding machines is so variable, and so many factors enter into the result, that no definite production can be stated. It is evident, however, that, with a given quality of material, the broader the machine, the greater the speed of the rollers and the thicker the roving, so also will the weight of the roving produced be increased. The following comparison of the weights produced by British and Continental sets of machines is instructive: The weights produced by the sets given in Tables II and III, IV and V, and VI and VII, would be about 40, 32, and 24 pounds per hour, respectively. The makers of Continental sets guarantee a minimum production on coarse materials of 90 pounds per hour; on medium-class materials of 60 pounds per hour; and on fine materials of 40 pounds per hour.

AMERICAN SYSTEM OF CARDING

71. Composition of Set of Machines.—The method or system of carding practised in America is quite different from the British system. The build and arrangement of their machines closely

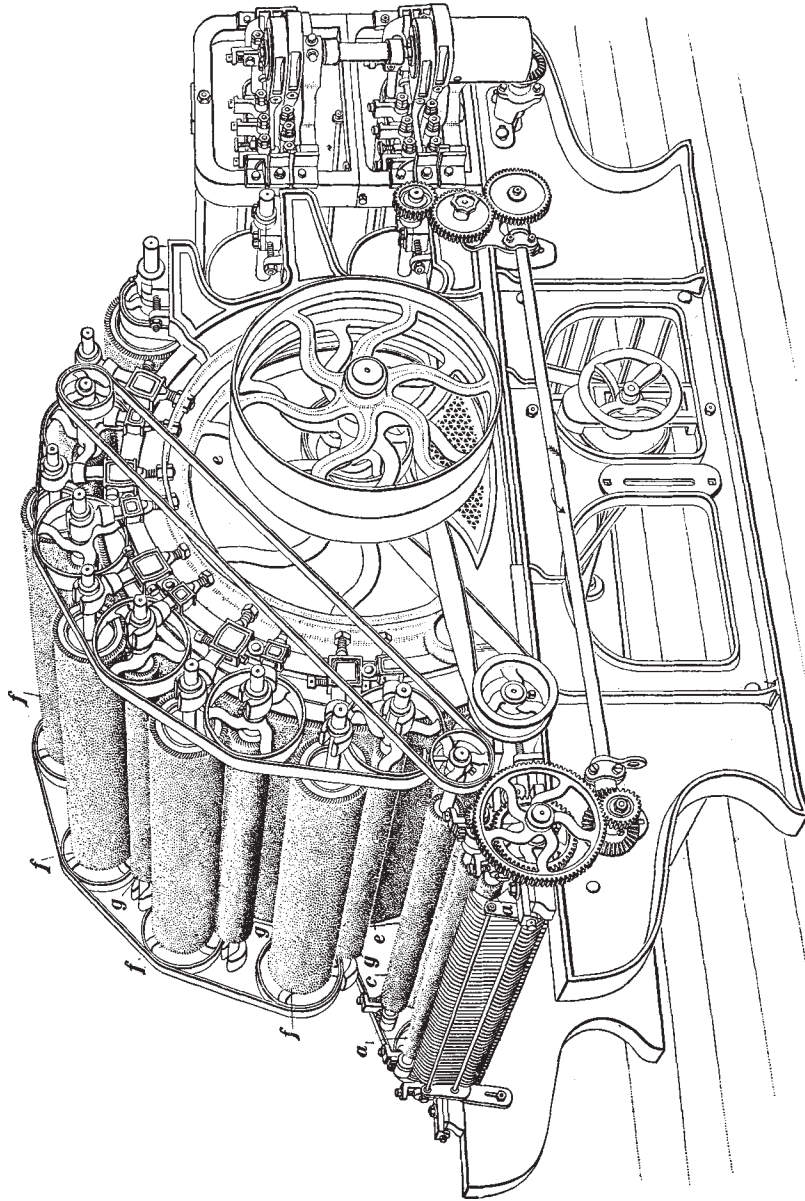

FIG. 31

resembles the Continental system, with the exception that the tape condenser is practically unknown. The scribbler, in America generally termed the *first breaker*, is built with one cylinder instead of with three or four cylinders, as in England. The scribbler is fed by a hopper feed and delivers to a balling machine and creel which supplies an intermediate, termed a *second breaker*, which has one cylinder. An Apperley feed carries and lays the sliver on the feed-lattice of the carder, usually termed the *finisher card*, which has only one cylinder.

72. Finisher Card.—The *finisher card* shown in Fig. 31 is a good illustration of the build of the machine, which possesses the same general features as the first and second breaker cards. This finisher card is equipped with a pair of feed-rollers *a*, $1\frac{3}{4}$ inches in diameter, and a feed-roller stripper *a*₁, $1\frac{3}{4}$ inches in diameter, a $5\frac{1}{2}$ -inch licker-in, a 3-inch licker-in fancy *c*, and a 9-inch tumbler. Over the main cylinder *e* are five pairs of workers *f* and strippers *g*.

73. British and American Machines Compared.—American machines are built narrower, a width of 48 inches being the rule and 60 inches the exception. There are usually six pairs of workers and strippers over the first and second breaker cards, the finisher card has only five, owing to the extra room taken up by the two doffers. Practically all the rollers are smaller in diameter than is the case with British machines, the workers being only 7 inches in diameter, the strippers 3 inches, and the doffers 30 inches; so that there is considerably less working or carding surface than in a British set of machines. The American machines are suitable for material that is fairly clean and of medium to fine quality and that needs comparatively little carding.

74. Condensers.—The double doffer principle is in general use in doffing the material from the main cylinder of the finisher carder on American machines. The rubbing motion of the condenser, Fig. 32, is of a distinctive American type. A portion of the material is removed from the cylinder *e* by one doffer *j*₁; the doffer is cleared by the *wipe roller w*, corresponding to the condenser stripper on English machines, the ribbons of material passing over the bottom series of rollers and under the top

rollers *u*, as shown. These rollers are covered with leather, and the upper series correspond to the top rubbers of the ordinary condenser, the lower series corresponding to the bottom rubbers. The rollers have a quick traverse motion, by which the ribbons

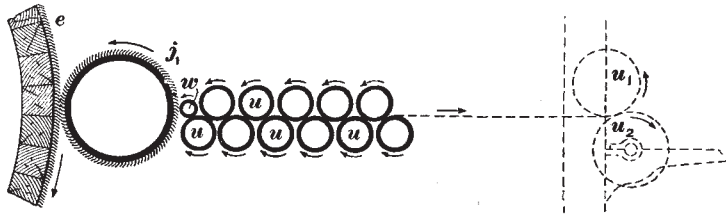

FIG. 32

are rubbed into round rovings, motion being given to the rollers in the usual manner by eccentrics. A slight draft or attenuation of the slivers is produced by having each roller running one tooth faster than the preceding one.

75. A combination of rubbing leathers and rollers is sometimes used ; an example of this type is shown in section in Fig. 33. Only one doffer is shown, the parts being duplicated for the other doffer. The doffer *j* is cleared by the wipe roller *w*, the ribbons passing through the rubbing rollers *u* and between a pair of

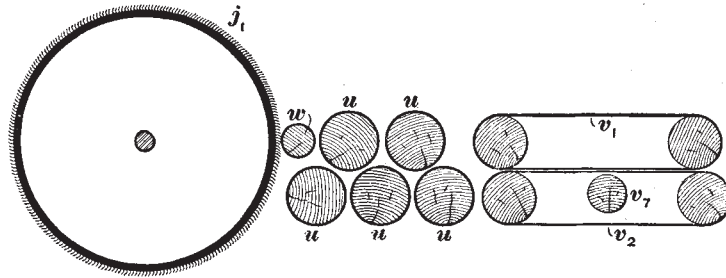

FIG. 33

rubbing leathers *v*₁, *v*₂, the roller *v*₇ keeping the bottom rubbing leather in contact with the top one. This type of condenser is intended to combine the superior drafting action of the roller condenser with the excellent rubbing motion of the rubbing leathers. The finisher card shown in Fig. 31 is equipped with this type of condenser.

WORSTED CARDING

PRINCIPAL FEATURES

WOOLLEN AND WORSTED CARDING COMPARED

76. Arrangement of Fibres.—It is unnecessary in this Course to deal fully with **worsted carding**, as that subject would be out of place in the treatment of woollen carding, but a brief reference is made to **worsted carding**, so as to explain the principal points of difference between carding in the woollen and in the **worsted** trades. Wool is carded on two systems for the production of two classes of yarns and fabrics, namely, the **worsted** system of carding, for the manufacture of **worsted** yarns and fabrics, and **woollen** carding, for the manufacture of **woollen** yarns and fabrics. The two systems are different both in the machines used and the results obtained, although the principle of carding remains the same.

Worsted carding tends toward the parallelization of the fibres, while **woollen** carding is more for the purpose of making a uniform mix, or blend, of the fibres, than to parallelize them. The tendency of any carding process is to lay the fibres parallel, but on a **woollen**-carding machine the material is usually removed from the machine by means of a side drawing, which tends to mix and cross the fibres; at the same time the side drawing is in some cases twisted by being passed through a rotating tube which also has a tendency to mix the fibres of wool. From the **worsted**-carding machine the material is removed in a web, passed directly through a stationary trumpet, and wound into a ball without twist, which tends to lay the fibres parallel in the direction of the drawing. This is the beginning of the parallelization of the fibres.

77. Definitions of Woollen and Worsted Yarns.—A **woollen yarn** is a thread spun from wool, the fibres of which are mixed

and crossed in every conceivable direction and which presents a rough, although uniform, surface appearance, as shown in Fig. 34 at (a). A **worsted yarn** is a thread spun from wool, the fibres of which lie smoothly in the direction of the thread and parallel to each other, as shown in Fig. 34 at (b). From the definitions and the illustrations it will be seen that a woollen yarn differs from a worsted in the arrangement of the component fibres; also, generally speaking, in the length of the fibres and in the process of manufacture, which in woollen spinning tends to an even artificial mixing and in the worsted to parallelism of the fibres.

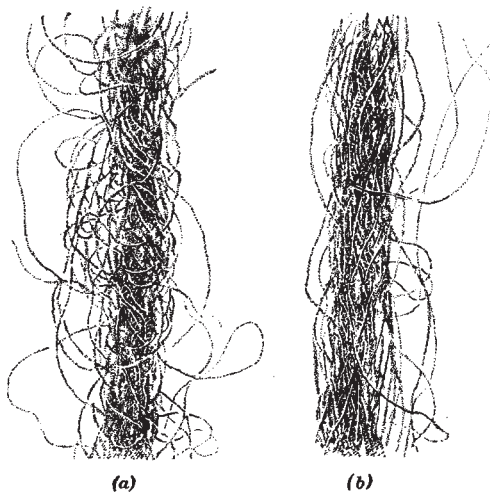

FIG. 34

78. Setting of Rollers.—In worsted carding the various rollers are not set so close to each other as in woollen carding; this is done in order to guard against the breakage and the consequent shortening of the fibre which would result from closer setting. Even if the fibre is broken, the deterioration of the material is not of so much consequence in the manufacture of a woollen as in the making of a worsted yarn, since all short fibres are removed by the subsequent operation of combing in worsted-yarn manufacture, and are consequently a dead loss so far as the manufacture of worsted yarn is concerned, although they may be used in woollen manufacture. Wool that is carded for worsted yarn is afterwards combed and put through various operations of drawing before spinning, while a woollen thread is spun directly after the carding process.

79. **Construction of Worsted-Carding Machine.**—Worsted carding is customarily performed on one machine, which is composed of two cylinders with their complements of workers, strippers, etc. The worsted-carding machine also usually carries, before the first cylinder, four lickers-in (or three lickers-in and a burr cylinder) and several other rollers. This, of course, makes a long machine, which has a large amount of carding surface.

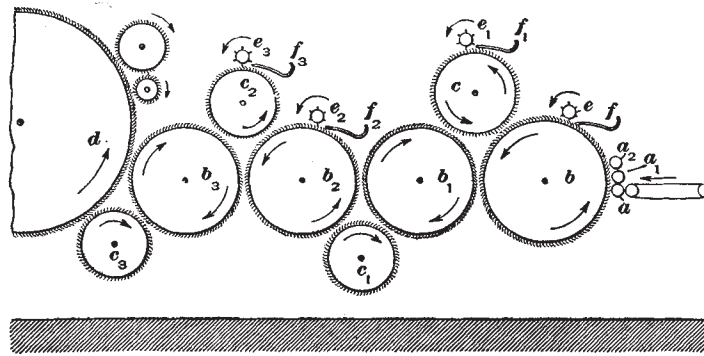

FIG. 35

Fig. 35 is a section taken through the opening rollers of a worsted-carding machine intended for carding fine materials. Only a portion of the first cylinder d and the first pair of workers and strippers are shown, the remaining part of the machine being similar to a woollen-carding machine with two cylinders.

80. **Operation of Worsted-Carding Machine.**—The action of the various rollers is as follows: The feed-rollers a , a_1 remove the wool from the feed-lattice, the roller a_2 acting as a stripper to the upper feed-roller. The licker-in b carries the wool toward the roller c , termed a *divider*, which, as it revolves with the points of its teeth against those of the licker-in, performs an opening action. Both the licker-in b and the divider c are stripped by the licker-in b_1 , as it revolves at a greater speed than either of these rollers. The licker-in b_1 carries the wool round till it comes in contact with the divider c_1 , where a similar opening process takes place, as occurred between the licker-in b and the divider c . The process of opening and stripping is repeated by the lickers-in b_2 and b_3 ,

and the dividers c_2 and c_3 , the main cylinder d clearing the lick-in b_3 and the divider c_3 . Thus, it will be seen that a gentle opening process takes place before the wool is submitted to the more severe action of the main cylinder and its complement of rollers.

81. Any burrs that may be present in the wool are knocked off by the burr rollers e , e_1 , e_2 , and e_3 , Fig. 35, into the trays f , f_1 , f_2 , and f_3 . The burr rollers have 1 to 6 wings, or blades, arranged on their circumference, and as the rollers revolve at a speed of about 600 revolutions per minute in the opposite direction to the points of the wire on the rollers, they will knock off anything that projects beyond the surface of the wire. Shives and similar substances drop out between the lick-in b_1 and b_3 and the dividers c_1 and c_3 .

The two main cylinders are each 54 inches in diameter, and have each three pairs of workers and strippers, the workers and strippers being 12 and 5 inches in diameter, respectively. Each fancy is 16 inches in diameter and the doffers 40 inches ; a large production of well-carded sliver is thus assured.

WOOLLEN CARDING

(PART 3)

CARD CLOTHING

SHEET AND FILLET CLOTHING

MATERIALS AND CONSTRUCTION

1. Kinds of Clothing.—The material with which the various rollers of the carding machine are covered, and by means of which the wool or other material is opened out and prepared for the spinning, is known as **card clothing**, and consists of wire teeth set in leather or some other suitable foundation and having a bend, or forward inclination, from a point called the **knee** of the tooth. The foundation employed for the clothing is usually one of two kinds, namely, (a) leather, which is used for *sheet clothing*, and (b) a fabric made of several layers of cloth with vulcanized rubber on the face, which is used for what is termed *fillet clothing*, *filleting*, or simply *fillet*.

2. Composition of Clothing.—**Sheet clothing**, having a leather foundation, is made in different qualities and thicknesses for the various rollers; for the feed-rollers and licker-in of the scribbler it is from $\frac{1}{8}$ to $\frac{3}{16}$ inch thick, while for the finest work the leather consists of the best calf and is not thicker than $\frac{1}{8}$ inch. In **fillet clothing** the cloth used alternately with vulcanized rubber is made of cotton or linen, or of a combination of those materials.

Copyrighted by International Textbook Company. Entered at Stationers' Hall, London

The crude rubber is treated with sulphur at a high temperature ; it then becomes vulcanized, and is suitable for cementing the layers of cloth together. The fillet may consist of from three to seven layers of cloth, though five layers may be said to form a typical foundation, and the layers are so arranged that the top layer of cloth is covered with rubber. It is important in woollen carding that the top layer should be of either leather or rubber, in order to prevent the oil used in the lubrication of the material from acting on the cloth ; otherwise the foundation of the clothing will soon be destroyed. The quality and cost of the clothing are in accordance with the number of layers in the foundation.

3. Wire.—Several points in regard to the wire which is inserted in the foundation should be carefully noted. These are (*a*) its character as to shape and preparation ; (*b*) the angle at which it passes through the leather ; (*c*) the angle at the bend, or knee ; (*d*) its size ; and (*e*) its setting in the foundation. Card clothing was formerly set with many kinds of wire, such as iron, steel, tempered steel, brass, and tinned ; but the best wire to use, and that which is now almost exclusively employed for woollen carding, is cold-drawn steel wire that is afterwards annealed, that is, softened by heating in a dull-red fire. The wire is then tempered to the required hardness, and is known commercially as *tempered-steel wire*. This wire makes a springy elastic tooth that is not easily bent out of place. The wire is better if tinned, as then there is no liability of rusting of the clothing during damp weather or if water is applied to the material. *Round wire* is generally used, although another kind, known as *elliptic wire*, which is made by passing round wire through heavy rolls and slightly flattening it out, is sometimes used. *Diamond-point wire* is often used for the licker-in and feed-rollers, this being almost oval in section and cut to a diamond point. *Triangular wire* has also been employed.

4. Advantages of Fine Wire.—Fine wire is more elastic than coarse wire, has a gentler action on the material, and also allows of a more open set of the clothing with the same number of points per square inch. If nothing but the wool to be carded

comes in contact with the wire, fine wire will be found to be as durable as coarse, but the fine clothing will necessitate more careful handling and grinding. When a uniform quality of material is carded, the clothing can be adapted to it; but where several kinds and qualities of wool are used, it is best to have the wire fine enough to handle the best quality of wool. The coarser kinds will then not be injured, and neither will the clothing, with proper care.

5. Type of Wire Gauge.—The usual method of finding the sizes of wires is by the use of a **wire gauge**, each size corresponding to a certain arbitrary number. A common form of wire gauge, which is capable of gauging the thickness of wire for numbers from 15 to 36, inclusive, is shown in Fig. 1. The wire is gauged by being tried in the slots in the gauge,

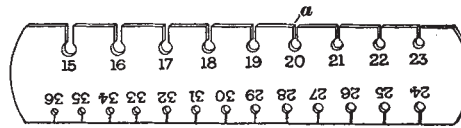

FIG. 1

the gauge number being indicated against the opening into which the wire fits easily, yet not loosely. Thus, if the wire fits into the slot at *a*, the gauge number is 20. Such a wire would not fit into the slot marked 21, and would be a loose fit in slot 19. The setting gauges used for determining the proximity of one roller of a carding machine to another, such as the setting of the workers to the main cylinder, are based on the same system of measurement as wire gauges.

6. Wire Gauges.—The British standard wire gauge, abbreviated S.W.G., is the standard authorized by Act of Parliament in 1884, though the Birmingham gauge, abbreviated B.W.G., also known as the Stubs, or the Old English standard, gauge, is more widely used. The Brown & Sharpe gauge is almost exclusively employed in the United States. It will be observed that the gauge numbers given in Table I are from 10 to 36; these include all the numbers of wire commonly used for carding machines.

7. Necessity for Determining Gauge of Wires.—The thickness of the wire used on each roller varies in accordance with the

position of the roller on the machine and with the purpose of the roller. The gauge is determined by the fineness and strength of the card clothing required for a set of machines ; for carding fine material, No. 16 wire may be used for the feed-rollers on the scribbler, No. 30 on the first cylinder, or swift, No. 31 on the doffer for the first cylinder, and No. 29 on the fancy. Doffers are usually covered with clothing set with wire one number finer than that on the cylinder, and the fancy with wire one to three

TABLE I
COMPARISON OF WIRE GAUGES

Gauge Number	British Legal Standard	Birmingham or Stubs or Old English Standard	Brown & Sharpe American Standard	Gauge Number	British Legal Standard	Birmingham or Stubs or Old English Standard	Brown & Sharpe American Standard
10	·1280	·134	·1019	24	·0220	·022	·0201
11	·1160	·120	·0907	25	·0200	·020	·0179
12	·1040	·109	·0808	26	·0180	·018	·0159
13	·0920	·095	·0720	27	·0164	·016	·0142
14	·0800	·083	·0641	28	·0148	·014	·0126
15	·0720	·072	·0571	29	·0136	·013	·0113
16	·0640	·065	·0508	30	·0124	·012	·0100
17	·0560	·058	·0453	31	·0116	·010	·0089
18	·0480	·049	·0403	32	·0108	·009	·0079
19	·0400	·042	·0359	33	·0100	·008	·0071
20	·0360	·035	·0320	34	·0092	·007	·0063
21	·0320	·032	·0285	35	·0084	·005	·0056
22	·0280	·028	·0253	36	·0076	·004	·0050
23	·0240	·025	·0226				

numbers coarser than that on the cylinder. This, however, depends on the opinion of the carding engineer, and the number is usually designated when ordering the clothing.

8. **Setting the Wire.**—The wire teeth are placed through the foundation by a machine that automatically cuts the wire and bends it in the form of a staple, pierces the holes in the foundation, thrusts the wire through, and then makes the knee, or forward bend. The wire is not passed straight through the

foundation, but at an angle, this angle being termed the *angle of setting*; the angle at which the teeth pass through or leave the foundation is very important, as it, together with the angle made at the knee, affects to a large extent the retentive power of the point of the tooth. This is shown in Fig. 2, which also shows the forward bend of the wire. The wire passes through the leather foundation *a* at an angle and is bent forwards again at the knee *b* until the point *c* touches the perpendicular *d e*, which is drawn from the point where the wire issues from the foundation. The angles of setting usually adopted on machines for carding material

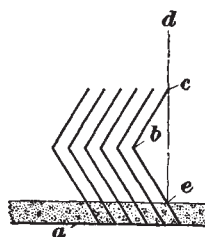

FIG. 2

TABLE II
ANGLES FOR SETTING CARD WIRE

Name of Roller	Angle for Fine Counts Degrees	Angle for Low Counts Degrees
SCRIBBLER:		
First cylinder .	65	63
Second cylinder	66	65
Third cylinder .	68	68
CARDER:		
First cylinder .	68	63
Second cylinder	70	68

for fine counts and those adopted on machines for low counts and quality of yarn are given in Table II.

9. Position of Point of Tooth.—The tooth should not be bent forwards past the perpendicular to any great extent, for if it is, the point will rise when the strain comes on the tooth, because of the arc in which the tooth moves, since the wire is

not held perfectly rigid, but is allowed a certain amount of play, owing to the flexible nature of the foundation and of the wire. Thus, if the point *c* of the tooth in Fig. 2 is inclined forwards past the perpendicular line *d e*, the strain on it when carding will raise its point and make the setting of the roller closer; that is, the slight raising of the point will have the same effect as setting the rollers nearer to each other. On the other hand, if the point of the tooth just reaches the perpendicular, any strain on the

tooth will have the effect of depressing the point ; this will increase the distance between the rollers or make the setting more open, thus easing the strain. In order to make this clear, reference is made to Fig. 3. If the tooth were pushed from c to c_1 , its point would be raised the distance x , which in some cases might be sufficient to put it in contact with another roller. Besides, there is a tendency for the tooth to straighten at the knee, which will also have the effect of raising the point.

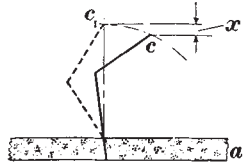

FIG. 3

10. Clothing for Workers and Strippers.—The general proportions of clothing suitable for the workers and strippers of a woollen-carding machine are shown in Fig. 2. It will be noticed that the distance between the knee and the foundation of the clothing is just a trifle shorter than that between the point of the tooth and the knee. This is about the right place for the forward bend of an ordinary working tooth to commence. The nearer the knee is to the point of the tooth, the stronger will be the clothing and the more tenaciously will it hold the fibres of the material ; on the other hand, the nearer the knee is to the base of the tooth or the foundation of the clothing, the more flexible will be the clothing and the more will its action resemble that of a brush.

11. Clothing for Fancy.—A section of a piece of card clothing such as is used for covering the fancy is given in Fig. 4. The tooth is longer and more flexible than the ordinary, and the knee b is lower, as the teeth of the fancy are set into those of the main cylinder and act as a brush ; also the point c of the tooth of the fancy clothing in the illustration projects beyond the perpendicular $d e$. This is not a disadvantage unless the bend is extreme, for as the teeth on this roller do not engage with the material, there is no danger of lifting the point of

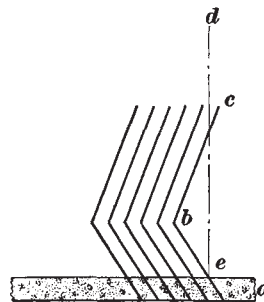

FIG. 4

the tooth, owing to the direction of rotation and the surface speed of the fancy ; however, if the bend at the knee is extreme, the fancy will pack the main cylinder with material. Straight wire is sometimes used for the fancy, but it often has a tendency to make a large amount of *fly* by throwing the material from the cylinder, especially if the clothing is applied with considerable tension and the fancy is not speeded just right. The teeth are also very liable to flatten after working for a time, as the whole force of their action comes direct on the foundation of the clothing. Wire with two bends has also been tried.

SIZES AND DETAILS OF CARD CLOTHING

12. Dimensions of Clothing as Manufactured.—Sheet clothing is manufactured in sheets that are from 5 to 6 inches wide and of a length equal to the width of the machine on which they are to be used. On sheets that are 6 inches wide there is a width of only about 5 inches in the centre of the sheet that is covered with wire ; this is a decided disadvantage, as it reduces the actual working surface by about 10 per cent. Further, the spaces where the sheets are joined create disturbing air-currents. Fillet clothing is made in long continuous strips that vary in width from $\frac{3}{4}$ inch to $2\frac{1}{2}$ inches, the most common widths being 1 inch, $1\frac{1}{2}$ inches, and 2 inches. The fillet is so made that when it is properly wound round the roller or cylinder the joining of two contiguous lengths is practically unrecognizable, the roller being thus completely covered with wire.

13. Kinds of Clothing Used on Different Rollers.—Sheet clothing is still largely used for covering the main cylinders, the workers, and the doffers, while the strippers are invariably covered with fillet. Leather sheets provide a stronger and firmer foundation than is possessed by fillet, but their firmness causes a tendency for a larger amount of the strain of carding to be borne by the wire rather than by the foundation, and, further, the wire on sheet clothing is liable to wear loose in the foundation much more quickly than the wire on fillet clothing. Sheet clothing is also more expensive. It is now becoming the practice

to cover all the rollers with fillet instead of sheet clothing. The back cylinder of the carder, that is, the cylinder next to the condenser, is very often covered with fillet, which gives a more even sliver, as there are no open spaces across the roller, and thus no irregularities in the roving as it comes from the condenser.

14. Twilled Order of Setting Teeth.—The teeth are set into the foundation in one of three methods, or orders, namely, the

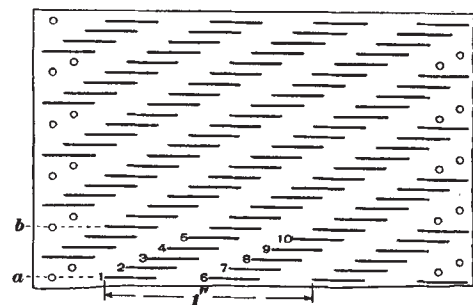

FIG. 5

twilled, the *plain*, and the *ribbed*. The *twilled order* is that in which the heads, or *crowns*, that is, the parts of the teeth that appear on the back side of the clothing, as shown in Fig. 5, are set in diagonal lines, like a piece of

twilled cloth. This method of setting teeth is the one most used for the fancy and for very fine card clothing.

15. Plain Order of Setting Teeth.—The plain order of setting teeth, shown in Fig. 6, is used on all sheet clothing for workers, doffers, and cylinders.

As it has a broader crown than the twilled order, it makes a stiffer and firmer clothing. The dots indicate the holes made by the teeth, where such teeth have been picked out, and serve to illustrate the arrangement of the points. When the plain order of setting is used for the fancy, the

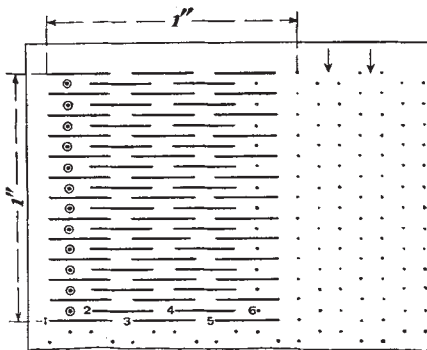

FIG. 6

teeth of adjoining crowns are apt to lean together and make

what are known as **rows** ; that is, the points on each side of the spaces indicated by the arrows come closer together in working and so form distinct spaces.

16. Ribbed Order of Setting Teeth.—The ribbed order of setting teeth, shown in Figs. 7 and 8, is used only on fillet, which must be made so that no points are lost and no vacant spaces formed where the edges touch each other. With the plain and twilled orders of setting, Figs. 5 and 6, the points represented by the small circles are wasted, since each crown must be represented by two teeth. Ribbed fillet may be either

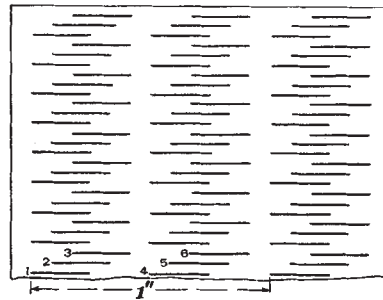

FIG. 7

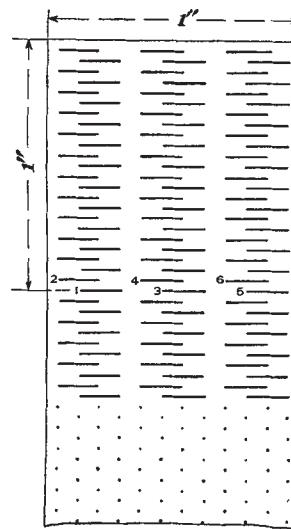

FIG. 8

twilled or plain. A portion of twilled ribbed fillet is shown in Fig. 7 and a portion of plain ribbed fillet in Fig. 8. In both cases the points come to the edges, giving an even distribution of wires and avoiding waste.

17. Designating Card Clothing.—The fineness of card clothing is designated by stating the *count* and the *crown*. In connection with fillet clothing, the *count* is the number of points in a row 5 inches long, counting lengthwise of the strip, while with sheet clothing it is the number of points in a row 5 inches long, counted crosswise. The *crown* is the number of heads, or crowns, per inch, measured lengthwise on sheet clothing and crosswise on fillet clothing. In Fig. 6, for example, there are 12 points per

inch, counting lengthwise, or $5 \times 12 = 60$ points in 5 inches ; therefore, the count is 60. The order of setting the teeth causes the crown to vary, and it is necessary to exercise care in calculating the crown of card clothing. With the twilled order of setting, Fig. 5, the portion between two corresponding rows, as a and b , may be termed a *division*, and in each division there are five transverse rows between a and b . Each row has 2 crowns per inch, as shown ; consequently, the total number per inch is $2 \times 5 = 10$, which is the crown of the clothing. In the illustration, these 10 crowns are numbered from 1 to 10. With a plain setting, Fig. 6, there are 3 crowns per inch in each transverse row, and two rows in each division, making $2 \times 3 = 6$ crowns, as marked. The crown of the clothing, therefore, is 6. With the setting shown in Fig. 7, as well as with that in Fig. 8, the crown is 6, as indicated. In practice, the dimensions of clothing are stated by writing the count first and then the crown, separating the two by a slanting line. Thus, the clothing illustrated in Fig. 6, which is 60 count 6 crown, would be designated as 60/6 clothing.

18. Calculating Number of Points.—According to the foregoing definition of count, the number of points per inch, counted vertically, is equal to $\frac{1}{5}$ the count. Also, as there are two points to each crown, the number of points per inch, counted horizontally, is equal to twice the number of crowns. Consequently, the number of points per square inch of card clothing is found by applying the following rule :

Rule.—*The number of points per square inch of card clothing is equal to twice the product of the count and the crown, divided by 5.*

EXAMPLE.—Find the number of points per square inch on a 60/6 sheet of card clothing.

SOLUTION.—Applying the rule, the number of points per square inch is

$$\frac{2 \times 60 \times 6}{5} = 144. \text{ Ans.}$$

19. Card Details.—In fine card clothing the count and the crown are often such that there are more points per inch counting vertically than there are points per inch counting transversely,

as, for instance, with clothing whose dimensions are 70/6, 100/9, 120/10, 130/11, and 150/12. When the fillet is wrapped round the roller, however, the points spread apart, or occupy a greater space, owing to the increased circumference when measured at the points of the wire; the difference between the count and the crown is thus neutralized.

The dimensions of the card clothing vary according to the position of the roller in the set of machines. What may be regarded as figures approximating to the dimensions of card clothing in general use are given in Table III, but it must be understood that card-

ing engineers have the rollers clothed according to their own individual opinions as to the gauge of the wire and other matters of choice.

TABLE III
DIMENSIONS OF CARD CLOTHING

Count	Crown	Points Per Square Inch	Gauge of Wire for Fancy	Gauge of Wire for Other Rollers
40	4	64	24	18
50	4	80	27	22
60	6	144	30	24
70	7	196	32	26
80	8	256		28
90	9	324		30
100	9	360		31
110	10	440		32
120	10	480		33
130	11	572		34
140	11	616		35
150	12	720		36

COVERING ROLLERS

COVERING WITH SHEET CLOTHING

20. Preparing for Covering Rollers.—Whenever old clothing is replaced with new, or after any roller has been trued, there arises the necessity for re-covering. This may be done with sheets, fillet, or rings. Before the card clothing is used it should be stored for a short time under conditions similar to those under which it will be required to work; if this precaution is not taken, the clothing will be liable to blister owing to the effect of the

change of atmosphere. Sheet clothing is used on main cylinders, doffers, workers, and fancies. The sheets for iron cylinders and doffers are sometimes made narrower than those for wooden ones, since wide sheets are more liable to swell or blister than narrow ones. On iron rollers the clothing does not bed so well as on wooden rollers, and it is impossible to renail the edges of the sheets if they become torn.

21. Sheets Required for Different Rollers.—The narrower kind of sheets for iron rollers are usually $4\frac{1}{2}$ or $4\frac{3}{4}$ inches wide ; thus, for a cylinder 50 inches in diameter, 31 sheets, each sheet often being termed a *row*, will be required, and for a doffer 36 inches in diameter 21 sheets will be required. The number of sheets or rows required for wooden rollers of similar diameters would be 28 or 29 for the cylinder and 19 or 20 for the doffer. A space of from about $\frac{3}{8}$ to $\frac{1}{2}$ inch between adjoining sheets must be allowed for nailing. Workers are generally covered with 5 sheets, and fancies with 7 sheets. To prevent the sheets from blistering, or rising in the centre, they should be put on the rollers with reasonable tension across the width of the roller and be securely fastened in place with $\frac{3}{4}$ -inch tacks, which are also known as 12-ounce tacks. The tacks used should be made without any web on the under side of the head, for the web is liable to cut the foundation.

22. Marking Out Rollers for Sheets.—The cylinder or other roller should first be marked off with a pencil, so that each sheet will be placed in the proper position and parallel to the axis of the main cylinder. This marking is usually done after the cylinder is trued up and with the turning lathe in position. With the cylinder turning, a mark is first made with a pencil, $\frac{3}{4}$ inch from each edge, and the circumference of the cylinder is divided on one of these lines, with a pair of dividers, into as many parts as there are sheets. Then, using the turning rest, which is parallel to the axis of the main cylinder, as a rest, a line is marked across the cylinder at each of the points spaced off with the dividers. The turning lathe is then removed and the sheets of clothing are applied. The upper edge of the sheet is placed on one of the lines drawn across the cylinder, and if the sheet

is made from the best calf, it is usually simply flattened out across the face of the roller ; in any case the amount of stretch given to the sheet is regulated according to the character of the material from which the sheet is made. Care must be taken not to nail the sheets too tightly or the teeth will be liable to become disarranged.

23. Holes in Foundation.—It is most important, when the card clothing is being made, that the holes in the foundation should be made slightly smaller in diameter than the wire ; otherwise, the teeth are very apt to wear slack or loose in the foundation. When this occurs the nailer is often blamed for the fault. After the sheet has been stretched across the roller it is held by a tack at each end, and tack holes are punched with a fine pricker along the top edge of the sheet, at a distance of about $\frac{3}{16}$ inch from the wire. The tack holes are spaced about $\frac{5}{8}$ inch apart for iron rollers and $\frac{3}{4}$ inch for wooden rollers. The tacks are then driven in, and the top edge of the sheet is thus attached securely to the roller.

24. Methods of Obtaining Tension.—When the top edge of the sheet has been secured, a clamp, as shown in Fig. 9, is attached to the lower edge of the sheet, which has a broader margin than the top, and a strap is passed through the link of the clamp and attached to

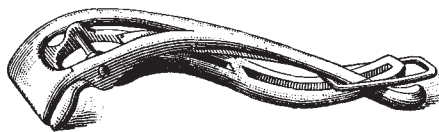

FIG. 9

a ratchet, by which the sheet of clothing can be stretched. In many cases a **stretcher** is used ; that is, a wooden lag, or bar, is wedged across the foot of the frame of the machine to serve as a fulcrum for the front end of the treadle, the clamp being then attached to the sheet and the strap to the treadle near the front end. By pressing downwards on the back end of the treadle, the requisite tension can be put on by the foot of the nailer. The ends of the sheet should always be stretched first and firmly tacked, after which the middle portion of the sheet may be stretched and tacked. While the tension is being applied to the sheet, the main cylinder must be prevented from turning. This

may be accomplished by means of a bar of iron propped against the bolts on the inside of the cylinder and resting on the floor, or by placing a pinion so that it will be wedged between the cylinder and the framing.

25. Laying Sheets on Rollers.—After the first sheet has been tacked on, the lower edge of the sheet should be trimmed to the pencil line and the operation repeated, the second sheet being nailed over the margin of leather left by the first sheet. Sometimes $\frac{5}{8}$ -inch tacks, which are also known as 10-ounce tacks, are used for nailing where there is only one sheet or layer of leather, but $\frac{3}{4}$ -inch tacks are always used where the tacks have to be driven through two layers of leather, that is, where the sheets overlap. When stretching the last sheet, it is necessary either to place a block of wood in the space between the first and second sheets tacked on, so as to provide an adequate rest for the clamp without injuring the clothing, or to lay one or more sheets on the clothing already nailed down, with the points toward the foundation.

26. Nailing Card Clothing.—After all the sheets are on, their ends should be drawn out and a single tack put in each. If the card clothing is sufficiently stretched and well tacked it will not blister. Iron cylinders have parallel rows of holes drilled in their surfaces and tapered hardwood plugs driven into the holes. The tacks are driven into these plugs when the clothing is applied. The hammer used for driving the tacks when sheet clothing is being applied is of a peculiar shape, as shown in Fig. 10; the head is

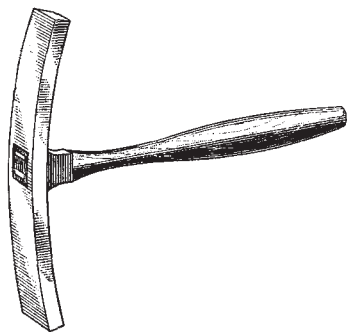

FIG. 10

8 or 10 inches long and the face of the hammer is 1 inch by $\frac{1}{4}$ inch. This shape of hammer is admirably adapted for driving in the tacks without in any way injuring the teeth of the card clothing, even though the space for tacking is only from $\frac{2}{8}$ to $\frac{1}{2}$ inch in width.

COVERING WITH FILLET

27. **Fillet-Winding, or Fillet-Mounting, Machine.**—The rollers of the carding machine that are not covered with sheet clothing, metallic wire, or rings are covered with fillet; such rollers are chiefly strippers and angle strippers. The fillet is applied or mounted on the roller in various ways, the object being to wind the fillet at a sufficient tension to prevent it from becoming slack. A machine for doing this is shown in Fig. 11. The desired

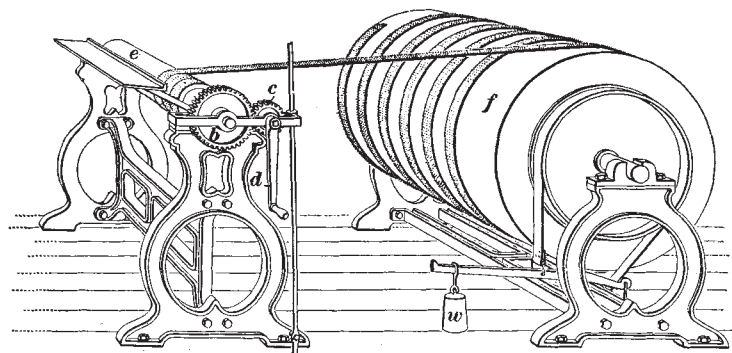

FIG. 11

length of fillet for any given roller is found as will be explained later, and one end is tacked to the large drum *f* round which it is wound; the other end of the fillet is then tapered and tacked to the roller *e*, which is to be covered, and which is turned by means of the crank *d* and gear-wheels *c*, *b*.

28. **Obtaining Tension by Adjustable Weight.**—The desired tension of the fillet is obtained by means of an adjustable weight *w*, Fig. 11, placed on a lever, to which a strap passing round a flange on the drum *f* is attached. By moving the weight, the required friction may be placed on the drum and, consequently, any desired amount of tension on the fillet may be obtained. When the end of the roller is reached, the fillet should be carefully secured and then trimmed off flush with the end of the roller. The taper at each end is necessitated by the fact that the fillet is wound on spirally, and the taper must therefore coincide with the angle of the spiral.

29. Fillet Mounting With Carriage.—A fillet-winding machine similar to the one described in the preceding article, except that it is equipped with a patent drum for regulating the tension of the fillet as it is placed on the cylinder, is shown in Fig. 12. An enlarged view is given in Fig. 13, in which it will be seen that it consists of a carriage *a* that slides on a bed *b*. Sufficient motion

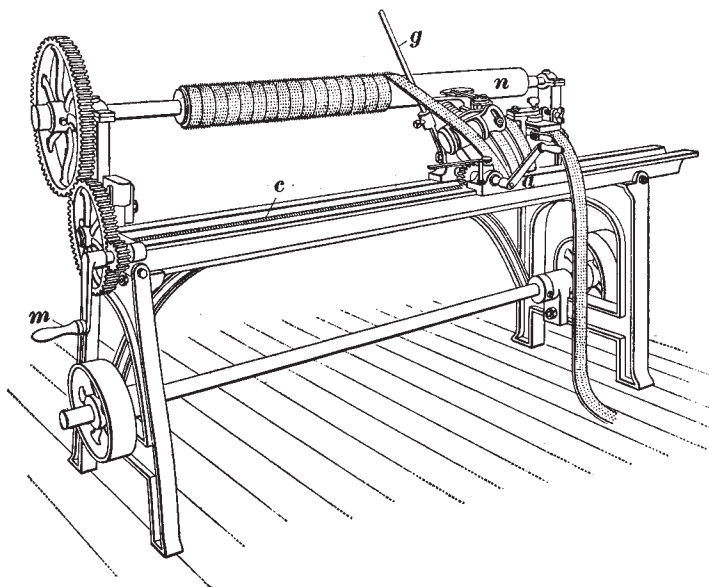

FIG. 12

is imparted to the carriage by means of a screw *c* to guide the spirals of fillet close up to each other. The fillet, when being wound, is usually placed in a basket, from which the end is taken and passed through the trough or feed-box *d* of the mounting head to what is known as the *cone drum e*, round which it is wrapped 3 times. The fillet emerges over the roller *f* and is guided on to the roller to be wound by the rod *g*.

30. Obtaining Tension on Cone Drum.—The tension is obtained in the following manner: The drum *e*, Fig. 13, which revolves as the fillet passes over it, is made in three sections, the first $6\frac{1}{2}$ inches, the second 7 inches, and the third $7\frac{1}{2}$ inches in diameter. The part with the largest diameter is covered

with leather so that this portion of the drum and the fillet revolve together; and as it requires a greater length of fillet to cover this surface than it does to cover either of the smaller sections, the fillet is drawn over the latter at a greater speed than that at which their surfaces revolve. The friction between the fillet and the drum produces the tension on the former, the

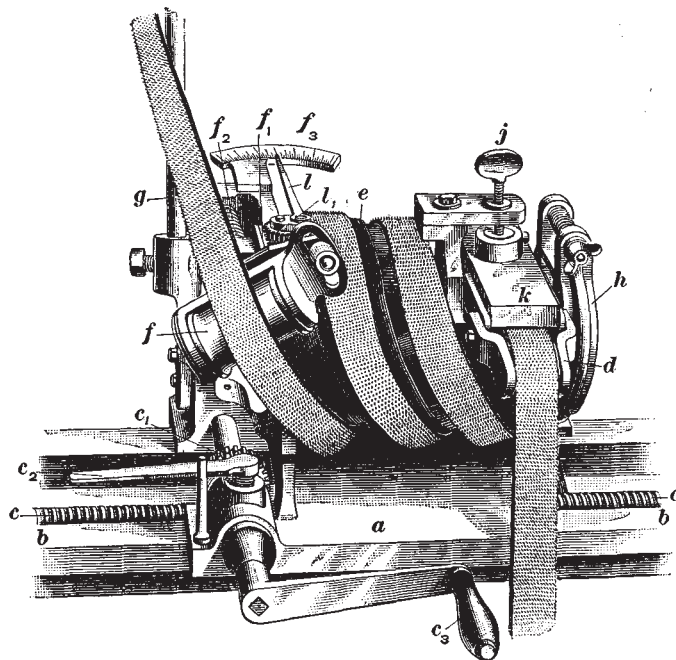

FIG. 13

amount of which may be regulated by the brake *h* which can be tightened on the drum shaft, and also by a thumbscrew *j* that presses the die *k* down on the fillet, which is drawn over a spring cushion. A tension of about 200 pounds may be obtained by means of the brake *h* alone, the rest being obtained by means of the thumbscrew *j*.

31. Indication of Tension.—The amount of tension with which the fillet is being wound is indicated by a finger *l* on the dial *f*₃, Fig. 13. This is accomplished by arranging the roller *f* to press

against a strong coiled spring f_2 , connection being made with a rack f_1 and pinion l_1 , so that the motion of the roller when acted on by the tension of the fillet is communicated to the finger and

indicated on the dial. By loosening the set-screw attached to the handle c_2 and then turning the handle c_3 , the worm-wheel c_1 will be rotated and the carriage a moved independently of the rotation of the screw c .

The frame shown in Fig. 12 is also used for truing wooden rollers, in which case the fillet-winding device is removed and a turning lathe substituted. In this case the frame is driven by a belt; but when winding fillet, motion is imparted to the roller n and to the winding device by means of the crank m .

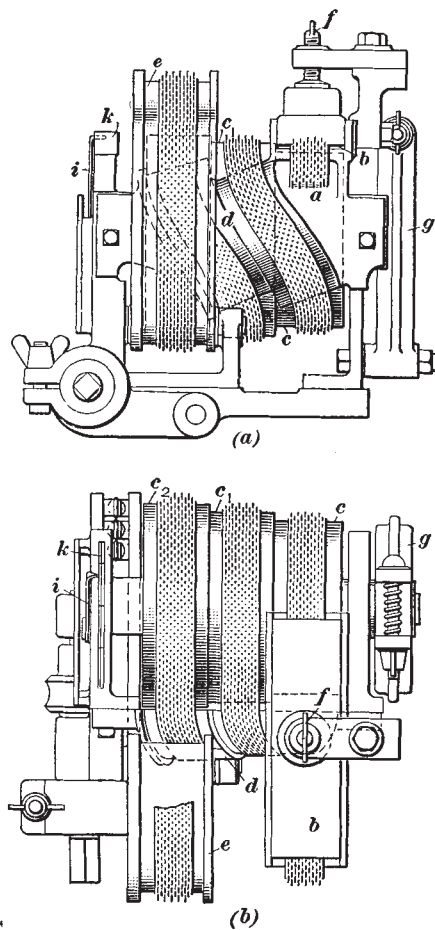

FIG. 14

in which (a) is a front elevation of the mounting head, (b) a plan view, and (c) an end elevation. In all views the same parts are indicated by the same reference letters. The fillet a passes through the feed-box b and on to the first step c of the

32. Arrangement of Cone Drum and Tension Lever.—An improved method of producing tension in the fillet is illustrated in Fig. 14,

cone drum. From this step the fillet passes over a guide plate *d* and is led on to the second step *c*₁, from which it is guided, in a similar manner, to the largest step *c*₂. The fillet then passes over a tension lever *e*, which also acts as a guide and gives the fillet a straight lead to the roller. With the mounting head shown in Fig. 13 there is no straight lead to the roller, and consequently there is some difficulty in keeping the fillet straight.

33. The passage of the fillet through the mounting head is shown clearly in the diagrammatic section, Fig. 14 (*d*). In this and in the other views it will be seen that the means for producing tension, up to the point where the fillet leaves the last step, are identical with those already described in connection with Fig. 13. The substitution of a tension lever *e*, Fig. 14, for a roller as shown at *f*, Fig. 13, gives additional tension to the fillet, owing to the friction incurred in passing over the tension lever.

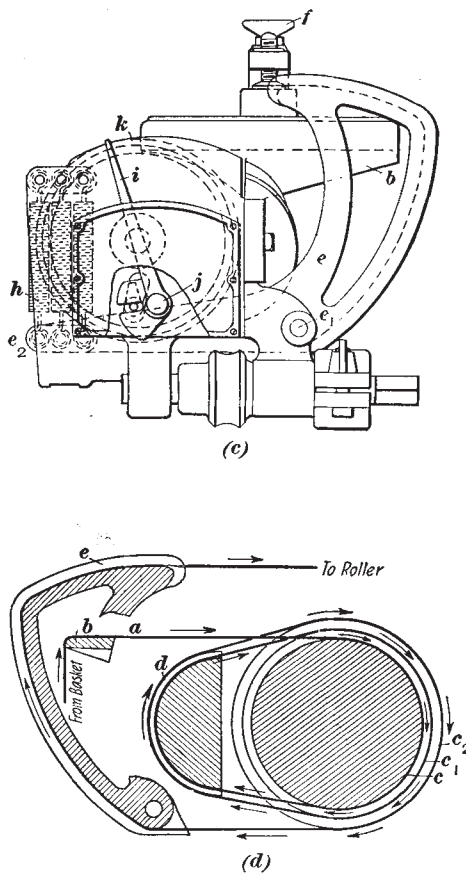

FIG. 14 (Continued)

The methods of increasing the tension by means of the thumbscrew *f*, Fig. 14, and the brake *g*, are also similar to those in Fig. 13, and are operated in a similar manner.

34. Tension Indicator.—Referring to Fig. 14 (*c*), the tension lever *e* is pivoted at *e*₁, and its lower end is prolonged to *e*₂, where it is attached to the springs *h*, which resist the pull of the fillet as it leaves the tension lever. A pin in the lower part of the tension lever actuates a finger or pointer *i*, which is pivoted at *j* and indicates the amount of tension on an engraved scale at *k*.

35. Appliance for Turning On.—A useful appliance for turning the rollers during the process of covering with fillet is illustrated in Fig. 15. The gear-wheel *a* is placed on the shaft of the roller to be clothed, and is firmly fastened to the shaft by means of the setscrew *b*, which, through a special gripping arrangement, has sufficient holding power to obviate any tendency to slip. Motion is given to the wheel *a*, and thus to the roller to be turned, by means of the handle *c* and the gear-wheels *d*, *e*, and *f*. The

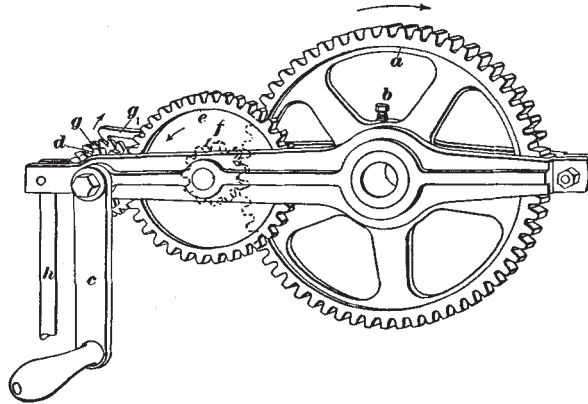

FIG. 15

ratchet wheel *g* and the pawl, or catch, *g*₁ are for the purpose of preventing the wheels from slipping back when the handle *c* ceases to be turned. A prop *h* supports that end of the device at which the turning handle is fixed. The machine is also arranged to drive the screw that gives the necessary traverse to the mounting head as the fillet is being wound on. This is done by means of chain gearing driven from the shaft to which the handle *c* is fixed, but is not shown in the illustration.

36. Amount of Tension.—The fillet must always be passed through the feed-box so that the teeth will point in the opposite direction to its motion, otherwise they will be injured. For winding main cylinders with 2-inch fillet a tension of 275 pounds is about right ; smaller rollers require less tension, as does also narrower fillet. Doffers may have fillet applied with a tension of about 175 pounds, while 125 pounds is sufficient for strippers covered with 1-inch fillet.

After large rollers are covered with fillet they should be allowed to stand for 3 or 4 hours in order that the fillet may become adjusted, and then it should be tacked crosswise of the cylinder. When covering with card clothing, if the roller is not reversible end for end, care must be taken to have the teeth of the clothing pointing in the right direction. As a rule, the strippers are covered with 1-inch fillet, while 2-inch fillet is used on all doffers and main cylinders when they are clothed with fillet, as is often the case with the last cylinder and doffer of the carder. The surfaces of iron rollers are sometimes painted, before winding on the fillet, to prevent them from rusting ; but this is not done so much at the present day. The usual custom is to brush the roller with linseed oil just before the fillet is wound on ; this prevents the backs of the teeth from rusting.

37. Calculation of Length of Fillet.—The following rule may be used to find the approximate length of fillet required to cover a given roller.

Rule.—*Multiply the diameter of the roller by its width, both in inches, and by 3.1416 and divide the product by 12 times the width of the fillet, in inches ; the quotient will be the required length of fillet, in feet.*

An allowance must be made for tapering the ends of the fillet at start and finish and also to leave enough to keep the tension when finally tacking the clothing to the rollers. One complete turn round the roller is sufficient, usually.

EXAMPLE.—What is the approximate length of 2-inch fillet required to cover a doffer that is 36 inches in diameter and 72 inches wide ?

SOLUTION.—Applying the rule, the length required is

$$\frac{36 \times 72 \times 3.1416}{12 \times 2} = 339.29 \text{ ft. Ans.}$$

38. When it is desired to obtain the exact length of fillet that will be required in covering any given roller, the following rule may be used :

Rule.—*Add the width of the roller to the width of the fillet, multiply the sum by 3.1416 times the diameter of the roller, in inches, and divide the product by 12 times the width of the fillet ; the result will be the required length of fillet, in feet.*

EXAMPLE.—Find the exact length of 1-inch fillet required to cover a stripper $4\frac{1}{2}$ inches in diameter for a carder that is 66 inches wide.

SOLUTION.—Applying the rule, the length of fillet required is

$$\frac{(66 + 1) \times 3.1416 \times 4.5}{12 \times 1} = 78.93 \text{ ft. Ans.}$$

It should be noted that fillet clothing is made in rolls or boxes, each containing from 700 to 1,000 feet, so that the length of fillet required is cut off after it has been wound on the roller.

COVERING RING DOFFERS

39. Mounting Small Rings on Doffers.—There is often some difficulty in clothing ring doffers, the rings being made endless and of a slightly smaller diameter than the doffer in order to fit it tightly. The following method of application, however, will be found to accomplish the purpose and not to injure the rings, provided that the doffers are not more than 16 inches in diameter. The doffer should be taken out of the machine and placed on end on a box, its shaft passing through a hole bored in the latter. To help in getting the rings on, a wooden cone about 6 inches long may be made, with its lower end of the same diameter as the doffer. Through its centre a hole is made, which allows it to be placed on the doffer shaft. The rings may now be placed over the cone and pushed down about an inch over the doffer. A square board 3 or 4 inches wider than the diameter of the doffer should be obtained and a round hole slightly larger than the diameter of the doffer should be cut into it. This can be slipped over the doffer and the rings may then readily be forced into place by pounding without bruising the leather. After all the rings are on the doffer it may be taken to the grinder, and

the rings, which are at varying distances apart, may easily be adjusted by means of a screwdriver or small stick. With the top of the doffer revolving toward the operator, but with the teeth pointing away from him, the screwdriver should be pressed against the side of the leather part of the ring, which may thus be slid in any desired direction.

40. Mounting Large Rings on Doffers.—One method of putting rings on doffers about 20 inches in diameter is to mount the roller in the grinding frame, this being a convenient position. With large-ring doffers from 36 to 44 inches in diameter, the usual procedure is to mount them in their bearings on the machine, and, with the cap of the bearing on one side removed, to raise the shaft sufficiently high as to be able to slip on the rings and leather strips, or, as they are often termed, *dividing leathers*, so that they hang loose between the roller and the framing. About four rings and leathers are slipped on at one time. The doffer is slowly turned while the operator forces each ring and divider on to the roller by means of a piece of wood in the form of a wedge.

Before doing this, however, a gauge must be made for spacing the rings in order that the divisions between them may be made equal. This gauge consists of a stick as long as the width of the machine and marked with as many divisions as there are rings, the latter to be spaced equally over a distance equal to the width of the clothing on the main cylinder.

41. Method of Marking Gauge Stick.—One method of marking off the gauge stick for a 60-inch double-doffer carder with 2 waste ends and 60 good ends is as follows: If the rings on the top and bottom doffers were all the same size, and no special waste end rings were to be allowed for, the rings would all be 1 inch in width; but, as the waste end rings must be wider and the rings on the top doffer narrower than the rings on the bottom doffer, the gauge stick must be marked so as to space thirty $\frac{7}{8}$ -inch rings 1 inch apart on the top doffer, while the bottom doffer must have thirty 1-inch rings $\frac{7}{8}$ inch apart. The rings producing the 30 good ends on each doffer will occupy a space of $30 \times (1 + \frac{7}{8}) = 56\frac{1}{4}$ inches, and as the carder is 60 inches