

FIG. 173.

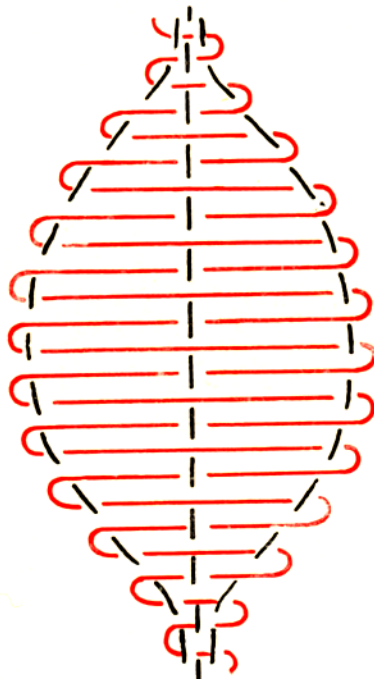

FIG. 174.

Fig. 173 represents the same cut but with more motions which gives greater facilities for throwing off the bobbin and gives a bigger fuller spot.

This cut is practical for 7, 8, 9, and 10 points.

The yarns used are 80/2 or 100/2 in bobbin and spot threads.

On a 9 point the quality would be 65 to 70 racks for 10.50 metres.

The quality varies infinitely according to the yarns used.

The bobbins can be cut to make the article more lacy according to the effect it is desired to obtain.

The advantages of this cut are: 1st, we can produce the same effect as with 3 bobbins in the ordinary way; 2nd, we can obtain relief or floating spots on clothing without spoiling the aspect of the clothing. As with 3 bobbin spots it is impossible to get a regular clothing; 3rd, we can have coloured spots without changing the beams and also have a different colour in each breadth.

	5	1	Beams	
Presses	R	R	1	2
	2	1	3	4
	32	32	5	6
	32	32	7	8
	24	24	9	10
	16	16	11	12
	12	12	13	14
	8	8	15	16
	0	0	17	18
	0	0	19	20
	0	0	21	22
	0	0	23	24
	0	0	25	26
	0	0	27	28
	0	0	29	30
	8	8	31	32
	12	12	33	34
	16	16	35	36
	24	24	37	38
	32	32	39	40
	32	32	41	42
	32	32	43	44
A presser sur le Spot				

Fig. 175.

We have thought it useful and interesting to reproduce the various effects that can be produced with the cut above described. (See Fig. 176).

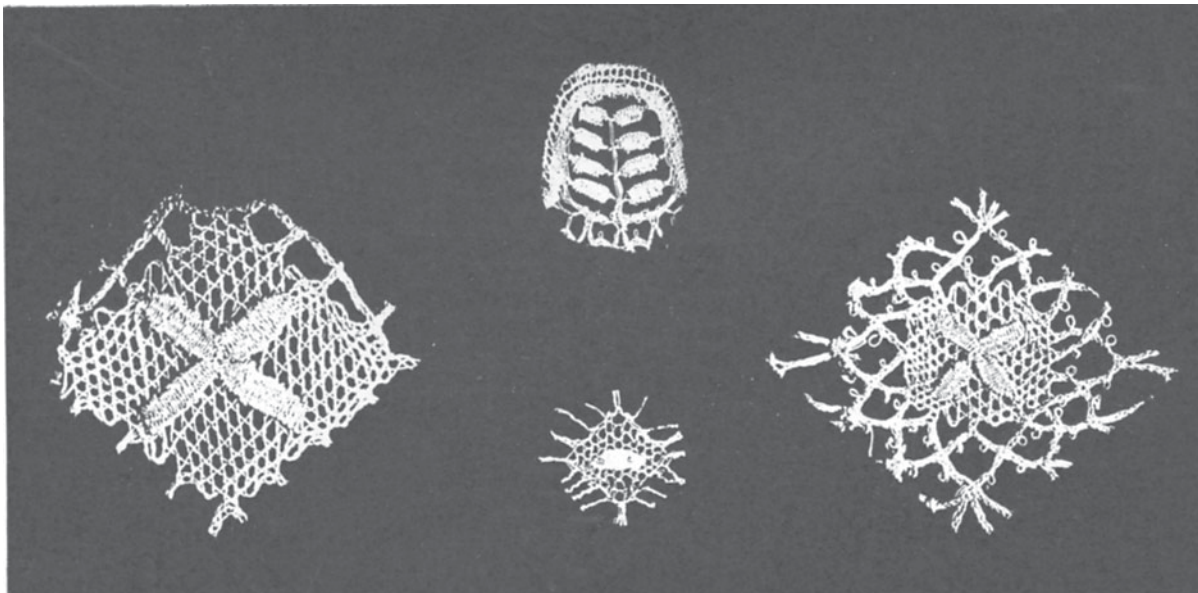

Fig. 176

Picot retourné

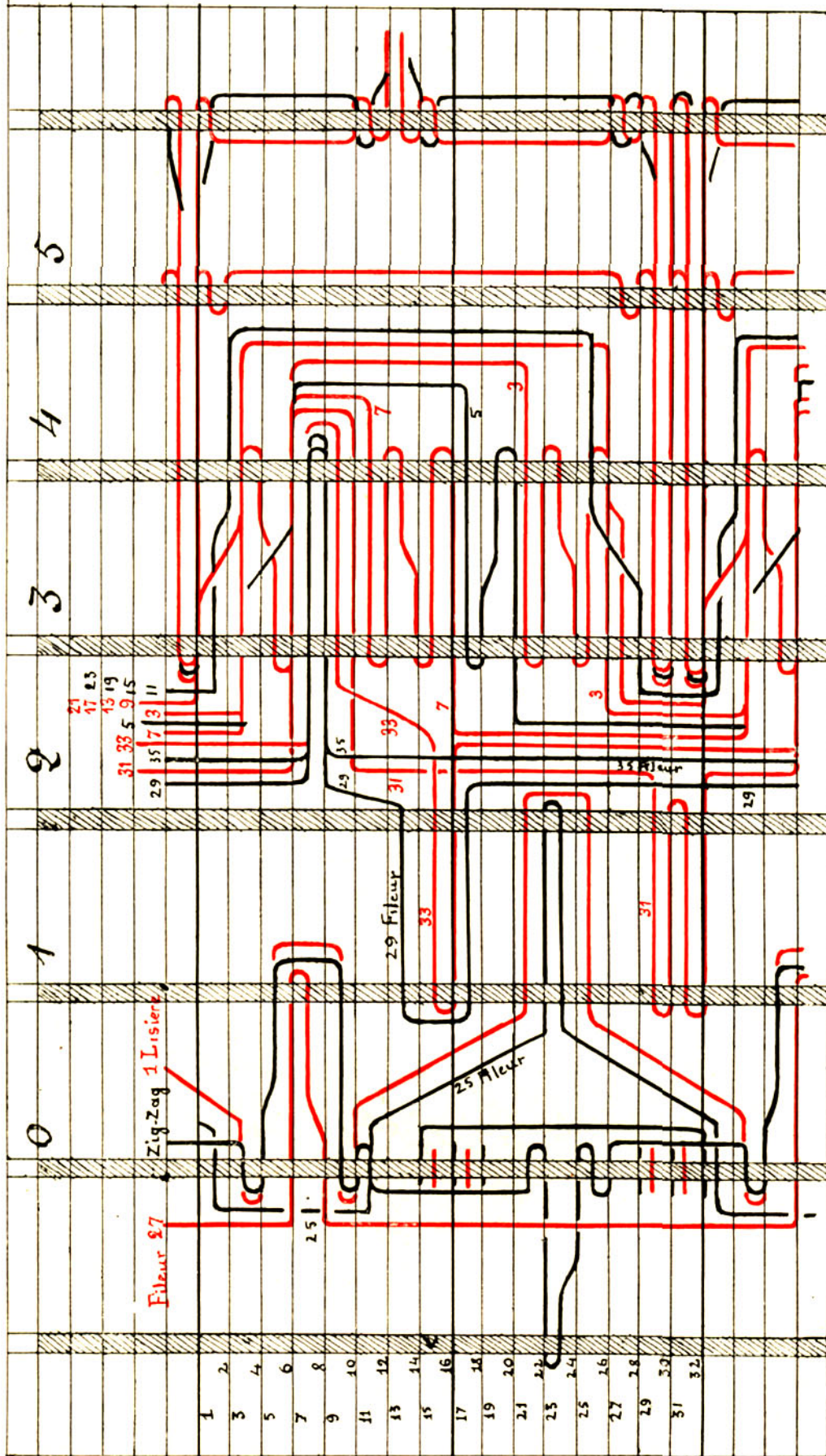

FIG. 176.

The yarns for these lacers should be very thick, say 20/2, so that by their thickness bobbins 3 and 4 turn over and form a loop the moment the purl is made.

The 2 lacers, 29 and 35, are helped by the 2 threads, 31 and 33, called tutors, which fall out when 29 and 35 are drawn. The yarns for these 2 threads may be 60/2 for 9 and 10 points.

This purl has the advantage of reproducing the aspect of a real lace purl.

We give (Fig. 177), the figure sheet of the work of the most important bars to be followed.

Bars 3, 5, and 7 form what is called the ticking front.

Fig. 178 represents the sketch of the turned over purl.

The bobbins 3 and 4 are marked in red and the threads in black.

We have not shown the work of the lacers, the lining threads, or the $\frac{1}{2}$ hole that joins the front to the net. To exactly understand the work of this front it must be done with strings from the draught.

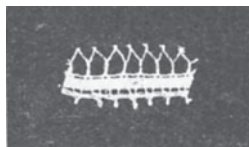

Finished aspect of a front with turned over purl.

DRAUGHTING PAPER.

Up to the present we have given a certain number of documents (draughts) on paper traced in different ways, but much larger than the papers usually employed, for the sake of clearness.

Papers ready traced to gauge and quality can be purchased from the trade stationers especially for draughting patterns with many motifs such as silk or platt goods which must be draughted proportionally to the design.

It is not the same in Valenciennes, as in these goods the pattern is produced by passes of threads that do not indicate correctly the shape of the motif to be reproduced.

We will, nevertheless, describe a method of tracing and ruling the paper itself.

Given a pattern to be draughted 48 centimetres per rack on a 9 point.

We take a trade paper traced with the motions only. The rack having 1920 motions, we divide 1920 by 48 so as to find how many motions per centimetre. This gives us 40 motions which we multiply by $25\frac{1}{2}$ millimetres, representing one inch, and thus have 102 motions corresponding to a space of 18 carriages, the gauge being 9 point.

We then measure the space of 102 motions on the draughting paper and divide this by 18 carriages and use these divisions to trace our spaces on the paper.

We now have our paper traced proportionately.

It is the same for all gauges ; for a 10 point we divide the space corresponding to the motions by 20, etc.



We give below the English numbers for 2 fold and 3 fold cotton yarns, with their corresponding French numbers, and the metric length per kilo.

NUMBERS ENGLISH		NUMBERS METRICAL		METRICAL LENGTH PER KILO
2 threads	3 threads	2 threads	3 threads	
10	15	8	13	8·466 metres
15	22½	13	21	12·669 „
20	30	17	26	16·933 „
25	37½	21	32	21·166 „
30	45	25	38	25·399 „
40	60	34	51	33·866 „
50	75	42	63	42·333 „
60	90	51	76	50·799 „
70	105	59	89	59·266 „
80	120	68	102	67·733 „
90	135	76	114	76·199 „
100	150	85	127	84·666 „
110	165	93	140	93·133 „
120	180	101	152	101·598 „
130	195	110	165	110·066 „
140	210	118	177	118·532 „
150	225	127	190	126·999 „
160	240	135	203	135·466 „
170	255	144	216	143·933 „
180	270	152	228	152·399 „
190	285	161	241	160·866 „
200	300	169	253	169·328 „
210	315	178	266	177·799 „
220	330	186	279	186·266 „
230	345	195	292	194·732 „
240	360	203	305	203·199 „
250	375	211	317	211·666 „
260	390	220	330	220·132 „
270	405	228	342	228·599 „
280	420	237	356	237·066 „
290	435	245	368	245·532 „
300	450	254	381	253·998 „

CONTENTS.



	Page		Page
About twist	1	8 motion front with crosses hidden	
Point or gauge	3	under the ties	53
About thread breaking	3	10 motion front with two corders...	55
Nets	4	12 motion front	56
Square Valenciennes net	4	16 motion front with visible crosses	
10 motion net	6	produced by the front ticking	
12 motion net	8	threads	57
14 motion, 2 threads per bobbin ...	10	16 motion front with bobbin twists	
16 motion net	11	and 2 front ticking threads ...	60
6 motion net, 1 thread per bobbin	13	28 motion front with top and bottom	
8 motion net, 1 thread per bobbin	14	bobbin twists and 2 front ticking	
10 motion net, 1 thread per bobbin	15	threads	62
12 motion net, 1 thread per bobbin	16	26 motion front with top and	
16 motion net, 1 thread per bobbin	17	bottom crosses	64
12 motion traverse net	18	8 motion gimped and tickined front	66
12 motion traverse net, 2nd way ...	20	6 motion weaver with selvidge	
12 motion round net	22	bobbin	67
20 motion round net	23	6 motion weaver without selvidge	
24 motion round net	24	bobbin	69
6 motion enzor net	26	8 motion weaver	70
8 motion enzor net	28	10 motion weaver with 3 straight	
10 motion enzor net	29	threads	72
14 motion enzor net	30	10 motion weaver with 2 chain	
Fronts	31	threads	74
8 motion front	31	12 motion weaver with 3 straight	
10 motion front	37	threads	76
12 motion front	38	14 motion weaver with 4 straight	
10 motion front	39	threads	78
6 motion front with enzor net ...	41	16 motion weaver with 3 straight	
Bobbin crosses and twists	43	threads	80
8 motion front with crosses ...	44	Lacing for insertion	82
8 motion front	46	Lacing for insertion without sel-	
10 motion front	47	vidge bobbin	84
10 motion front with visible crosses	48	Lacing in which the bobbin goes	
12 motion front with crosses and 9		through the points of the weaver	85
band threads	50	38 motion spot	86
14 motion front with crosses and 9		32 motion spot	88
band threads	52	Spot or 12 motion regular net ...	90

	Page		Page
Spot on 10 motion regular net ...	92	Draught of gimped Valenciennes	
Spot on 8 motion net	94	pattern with passed front,	
6 bobbin open spot... ..	96	sketch, figure sheet and design	109
6 motion gimped front	98	Cut of clothing for Honiton braids,	
8 carriage double insertion, called		spots, etc.	114
“ trou-trou ”	99	Ribbon of which the gimps twist	
4 spots on square net	100	together... ..	116
Front made with one thread and		Method of draughting a passed	
one bobbin	101	Valenciennes pattern	118
Spot on square net, two threads per		Method of squaring a design and	
bobbin, also spot on 12 motion		draughting a gimped Valen-	
net, one thread per bobbin ...	102	ciennes pattern and finding the	
12 motion net, 1 thread per bobbin	103	quality	121
20 motion gimped front	104	Cluny spot made with one bobbin	122
Tickined scallop on 8 motion net...	105	Turned over purl, draught and	
Figure sheet of the scallop ...	106	figure sheet	125
Sketch of the scallop	107	Method of tracing draughting paper	
6 bobbin gimped spot on 6 motion		to quality	128
enzor net	108	English numbers or counts of cotton	
		yarns and the corresponding	
		French number and the metric	
		length	129



SECOND PART.

THE
TWISTHAND'S SCHOOL.

PREFACE.



To make a Twisthand of an adolescent by written demonstrations is not an easy matter, but being convinced, from our knowledge of the situation, that it will be rendering a great service to our young workers to place in their hands the means of familiarising themselves with the various parts of the machine that they will have to know and develop if they are to become competent workmen, able to make an article to-day and a new one to-morrow if necessary.

With the collaboration of capable workmen we have tried to resume here all that we consider necessary for the future twisthand to know so that he will not become what is known as a mere machine hand.

To attain this end we have tried to describe simply and as clearly as possible, the different parts of the machine that the twisthand should know.

We are not attempting to teach mechanics, for that is no part of a twisthand's duty, who, when an accident occurs, is obliged to refer it to his foreman.

Our desire is that a young apprentice, having worked as a threader, and used to the manipulations of bobbins, carriages, etc., may, with the help of our book, quickly understand and be able to execute the work he will be called upon to accomplish in the future.

We dare to hope, in view of the great progress that our beautiful industry is making every day, that our counsels will be followed and we shall only be too happy if we have been enabled to augment its prosperity in some measure.

This work is addressed specially to young men destined to become twisthands; and to young draughtsmen who also need to thoroughly understand the lace machines, a knowledge difficult to acquire with present day methods, for no book has ever been published treating this matter.

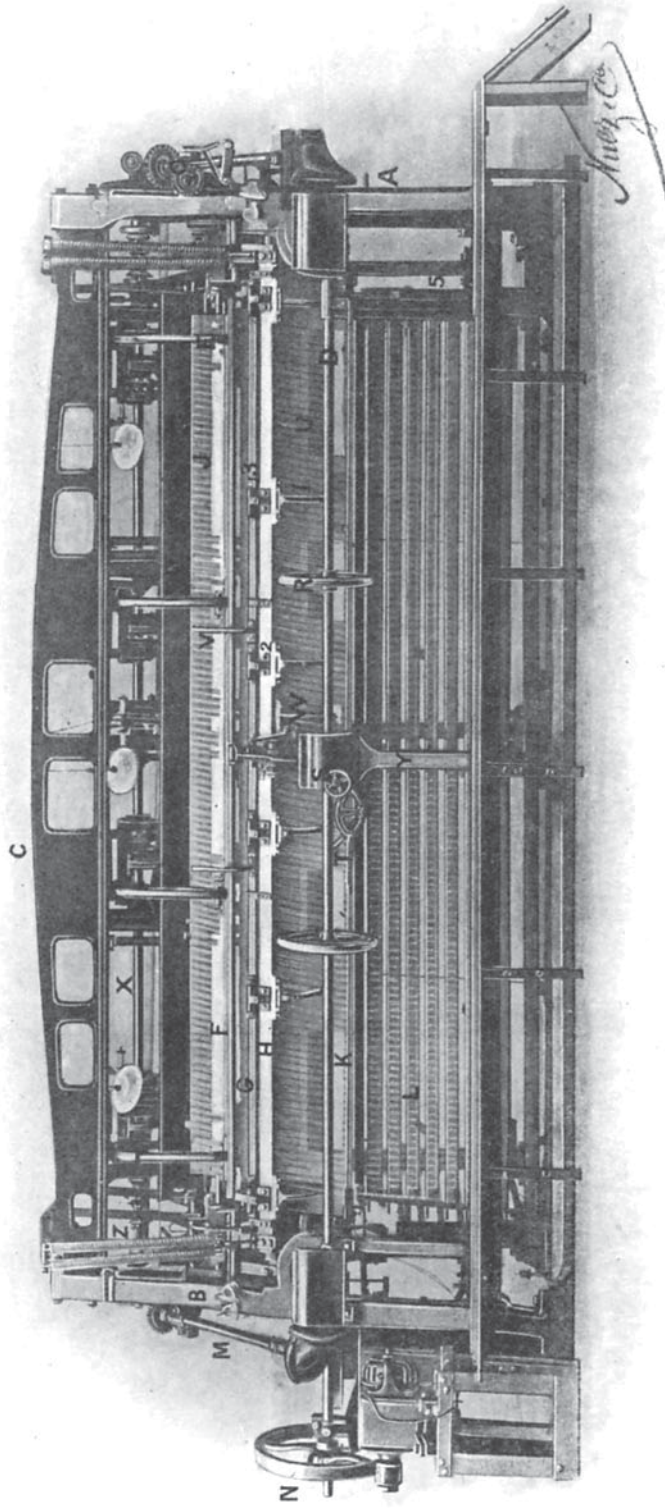

**Denomination of the
component parts of the
Machine**

A	Machine ends or standards, Jacquard end	L	Beam sieys	V	Catch bar handles
B	Machine ends or standards, fly wheel end	M	Back shaft pinion	W	Comb bar handles
C	Tie bar	N	Fly wheel	X	Carn shaft
D	Front shaft	O	Worm	Y	Cradle shaft
E	Point arms	P	Bars hooked spring end	Z	Landing bar spring
F	Point bar	Q	" Jacquard end	1	Landing bar feet
G	Catch bar	R	Hand wheels	2	Catch bar feet
H	Landing bar	S	Brake wheel to fasten frame	3	Jacquard fasteners
I	Goose neck	T	Belt rod	4	Jacquard fasteners
J	Lace roller	U	Threads from sieys to bars	5	Spring hook frame for beams
K	Warp sieys				

CARRIAGE.

We begin by defining a *carriage*.

The *carriage* is always made of rolled steel so as to give it the necessary fineness and stiffness, according to the gauge.

The spring which maintains the bobbin in its position, also gives the bobbin thread its proper tension.

It is composed as shown in Fig. 1.

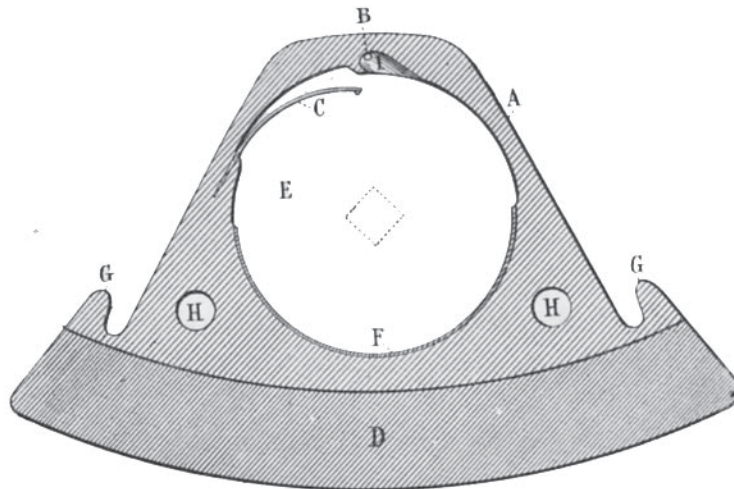

FIG. 1.

DESCRIPTION.

- A** Breast.
- B** Top in which the hole for the bobbin thread is punched.
- C** Spring that holds the bobbin in its place.
- D** Blade. Part ground away which passes in the comb blades.
- E** Space for the threaded bobbin, that is to say, filled with silk or cotton.
- F** Verge that holds the bobbin.
- G** Carriage nibs that take the catch bars.
- H** Holes to lighten the carriage.
- I** Milled out part to allow bobbin thread to pull centrally.

BOBBIN.

The *bobbin* is made of brass and is composed of 2 discs rivetted together, having a part dished or turned out to make room for the thread destined to make the net or clothing, concurrently with warp threads or independent beams having its periphery turned over to form a lip that fits in the verge of the carriage.

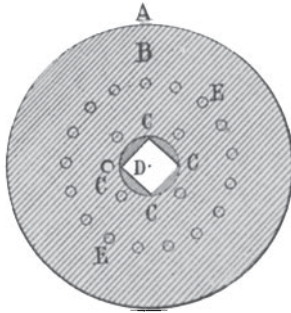

FIG. 2.

The most minute care should always be observed in the manipulation of bobbins and carriages to ensure the right working of the machine.

DESCRIPTION.

- A Lip of the bobbin.
- B Dished or turned out part, containing the thread.
- C Body of the bobbin.
- D Square hole for the winding spindle.
- E Rivets holding the 2 discs, forming the bobbin together.

MANIPULATION.

The *manipulation* of the threads employed in the manufacture of lace, is an important matter because of their fineness and often lack of resistance.

They require a great sensibility of touch that can only be acquired by long practice.

It is evident that good yarns facilitate the acquisition of this sensibility of touch which is so necessary to rapidly knot together the broken threads.

As soon as the future twisthand is habituated to this operation he will be able to help the workman to tie out the empty beams and warps.

The tools required by the apprentice are very limited ; a hook to enter the threads through the sleys and bars ; a pair of scissors to cut the the knott ends as short as possible, to avoid thread breaking are sufficient.

The apprentice should be careful not to put his hands on the machine while it is in motion, for fear of a personal or material accident. He should stand before his machine with ear alert to its sound so as to stop it at once at the least abnormal noise, so as to prevent or minimise an accident, and warn the workman, should he be absent at the moment of stopping the machine.

To observe well and follow the workman's counsels is the surest way of becoming a good workman.

BARS.

The *thread bars* are placed in the frame between the comb bars upon brackets, by means of slots punched in the bars, they are fastened at the Jacquard end by pull bits to draw bolts sliding through the dropper boxes (or levers). (These droppers cause the bars to rise or fall, that is to say, change from carriage to carriage for reproduction of the pattern).

At the flywheel end they are hooked to springs fitted to a spring frame. These springs keep the bars at the right tension to do their work properly so as to produce faultless tissue upon the whole length of the machine (Fig. 3).

We give at Fig. 3 a view of the bars passing through the sleys fitted to the carcass (spring end).

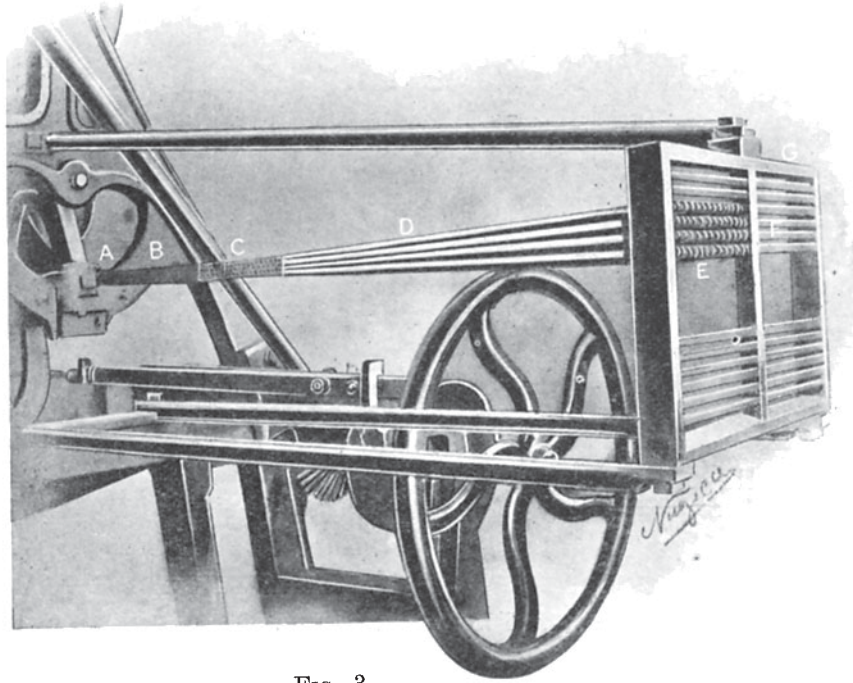

FIG. 3.

DESCRIPTION.

- A** Slews through which the bars pass in the well of the machine.
- B** End of the bars.
- C** Spring hooks hooking the bars to the springs.
- D** Springs giving the proper tension to the bars.
- E** Hooks hooking the springs to spring grid.
- F** Spring grid.
- G** Frame of the grid.

To ensure the right working and keep the right width between the comb bars, the bars are passed through sleys fitted to each end of the machine.

To enable them to carry the threads from carriage to carriage the bars are punched with holes at absolutely regular intervals. These holes are punched on the inside itself, that is to say, from the comb bar.

Oil must not be allowed to get between the bars, and to avoid this it is well to cover them below the hinges or at any other place where oil might fall upon them.



FIG. 4.—BAR.

DESCRIPTION.

- A Body of the steel bar.
- B Slot to receive the bracket.
- C Holes punched to the gauge of the machine to receive the threads.
- D Hook for Jacquard pull bit.
- E Slot for spring hook.

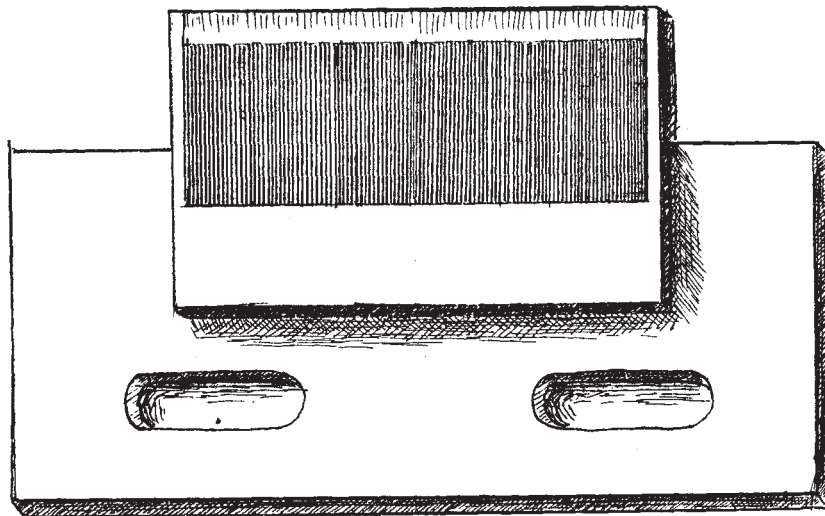

FIG. 5.—TOP BAR END SLEY.

BRACKET.

To hold the bars straight in the machine and, at the same time, prevent them rising and touching the carriages, a support is used fitted with a pin and called a bracket.

The bracket pin is always the same length as the width of the well of the machine (that is to say the width between the 2 comb bars).

DESCRIPTION.

- A Bracket stem.
- B Slot to regulate position.
- C Pin upon which the bars are placed.
- D Split pin to keep bars in their places.

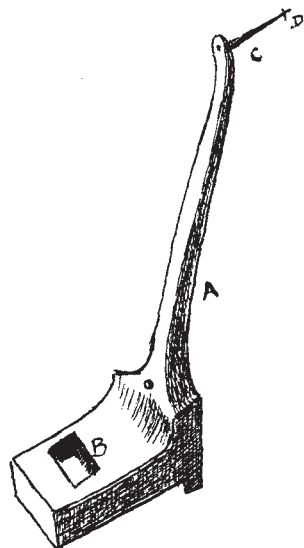

FIG. 6.

WARP SLEYS.

This sley is made of sheet iron and punched in its whole length with holes corresponding to the gauge or point of the machine.

In width, the holes should correspond to the width between the two comb bars, taken from the centre of the machine (more fully described on page 26).

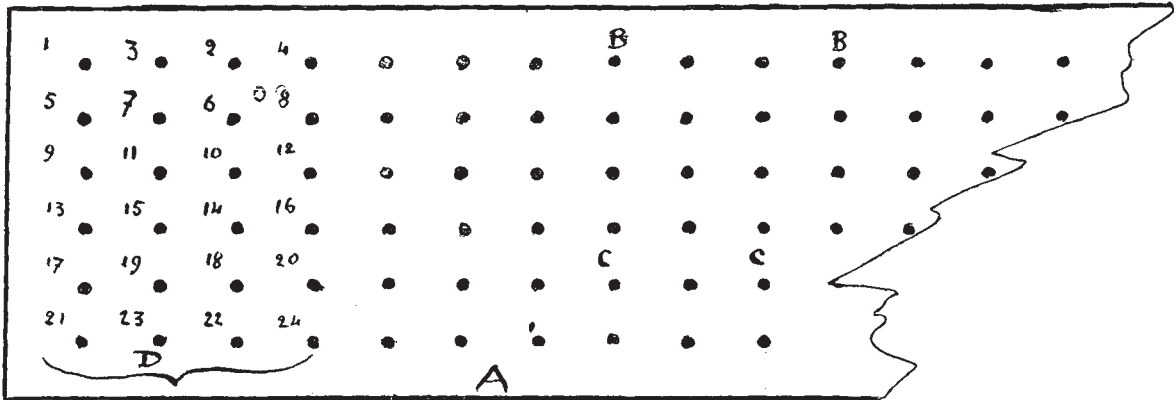

FIG. 7.

DESCRIPTION.

- A Sheet iron plate.
- B Holes punched to gauge of machine.
- C Holes punched to width between comb bars (see page 26).
- D Table of a 4 division set out.

BEAM SLEYS OR EYELET RODS.

Beam sleys, or eyelet rods, are adapted to each division or tier of beams. They are also punched or divided in their length to the gauge of the machine, so as to allow in the division of the breadths the placing of the threads from the beam.

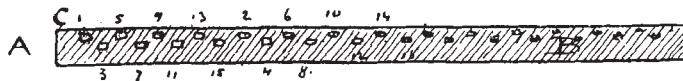

FIG. 8.



FIG. 9.

DESCRIPTION.

- | | |
|--|--|
| <ul style="list-style-type: none"> A Small metal sley. B Holes to gauge of machine. C Table of the set out. | <ul style="list-style-type: none"> D Rods. E Eyeletting to gauge of machine. |
|--|--|

BEAMS.

The beams, being filled with threads or the raw material to be used are placed in the beam arms, which are divided into several tiers so as to facilitate the setting out of a warp or a certain number of beams.

The beam is made in two parts, called “he” and “she” (Fig. 10). They are fitted with a collar on the axle at each end, upon which the cord is rolled, that is, fastened to the spring which regulates the tension required for the pattern.

Keep these collars as clean as possible, so that the cords will not stick, which prevents the proper regulating of the tissue, and also causes thread breaking by preventing the beam giving off the yarn.

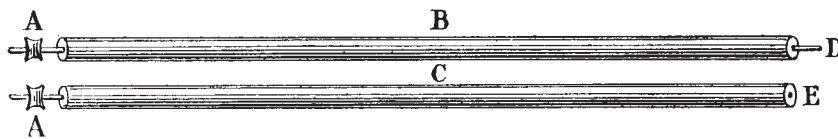

Fig. 10.

DESCRIPTION.

- A** Collar for the cords.
- B** Body of beam, “he” side.
- C** Body of beam, “she” side.
- D** Axle joining the 2 parts, **B** and **C**.

At the back of the machine, outside the beam arms, is a standard, pierced with holes corresponding to the number of beams for which the machine is fitted. In these holes are screws having a winged nut at one end, and a hook at the other to which the springs are hooked that are attached to the beam cords.

Be careful to reject greasy cords, and to have springs of a suitable tension for regulating the article to be made.

We describe (Figs. 10, 11, 12, 13 and 14) the various parts of the beam tackle.

We give (Fig. 15) a general view of the beams placed in a machine, seen from the back at the spring end, and (at Fig. 16) the same seen from the Jacquard end.

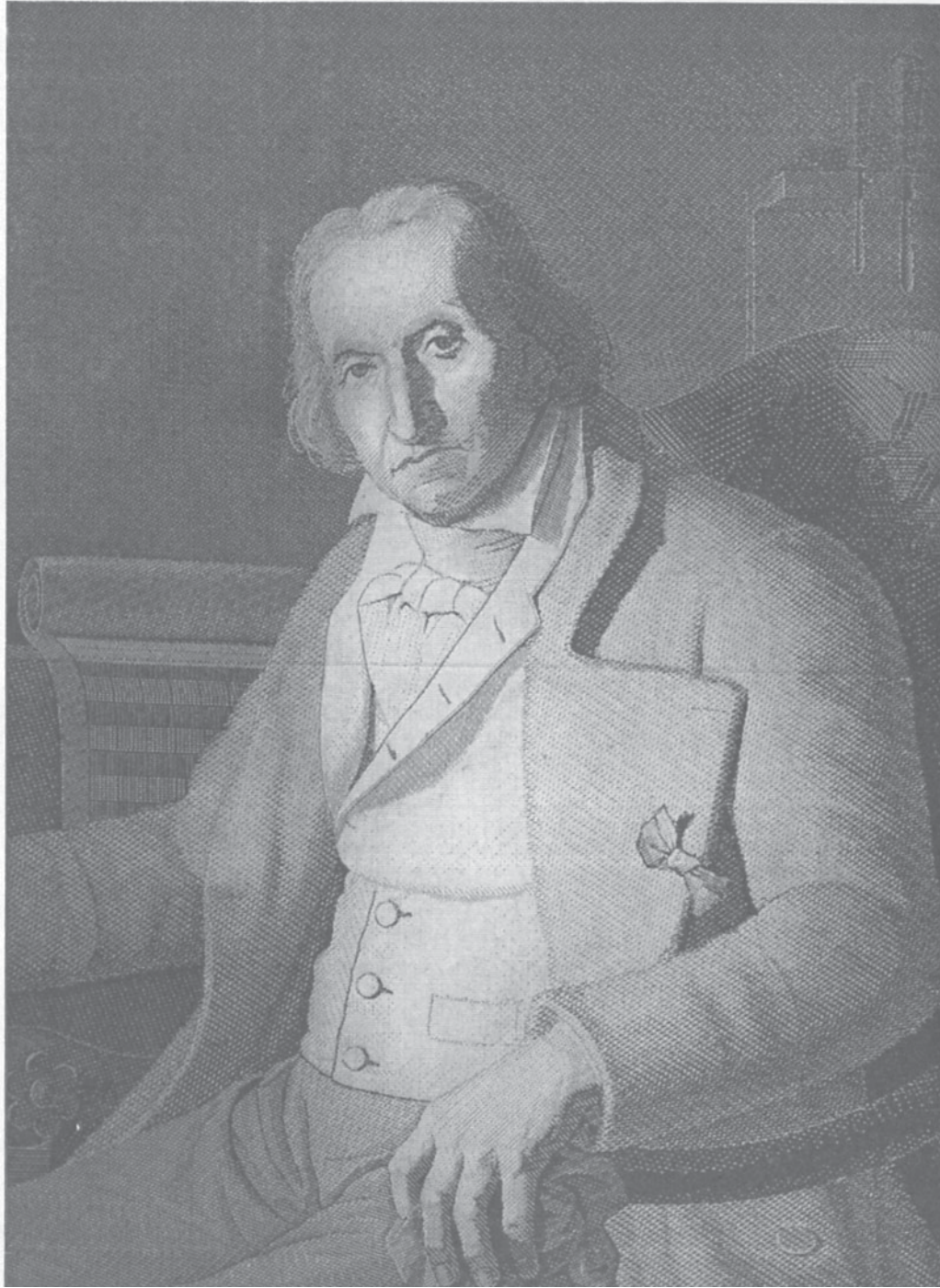

Jacquard.

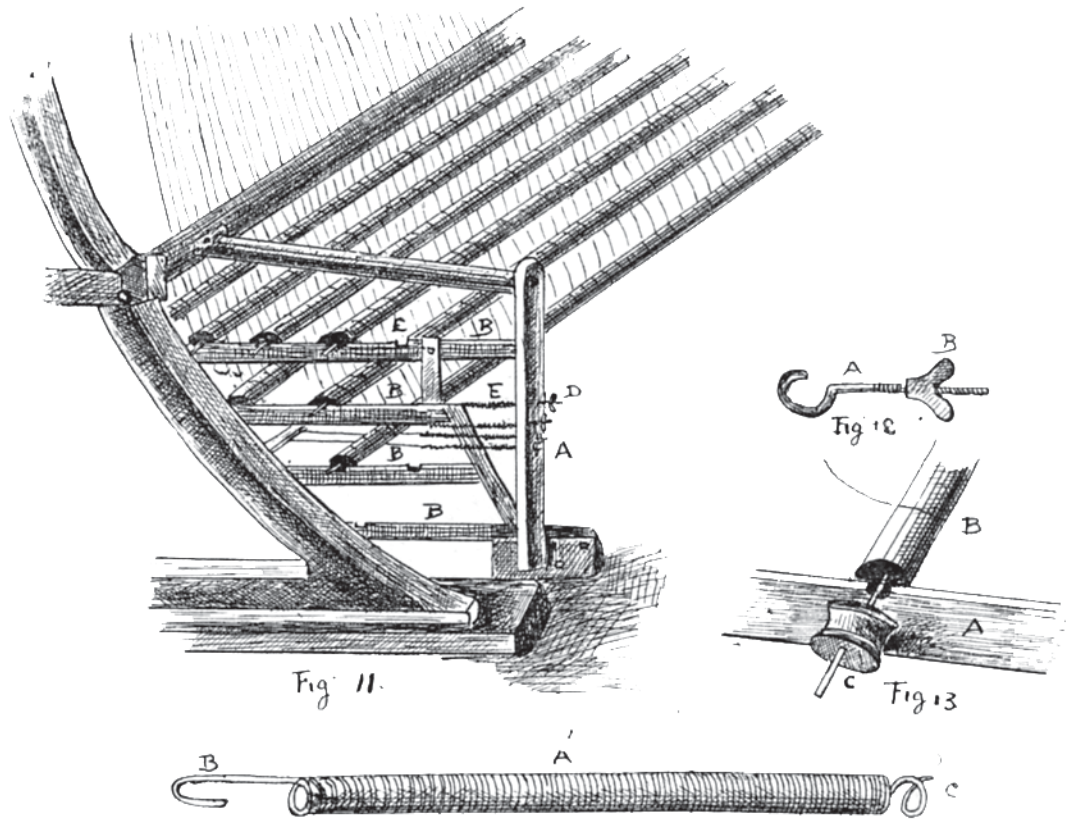

FIG. 11.

DESCRIPTION.

FIG. 11.

- A** Upright to which the beam arms are screwed.
- B** Beam arms.
- C** Parts cut out of beam arms to receive beam axles.
- D** Hooked screw for beam spring.
- E** Beam springs.

FIG. 12.

- A** Hook for beam springs.
- B** Winged nut for same.

FIG. 13.

- A** Beam arm.
- B** End view of beam in its place.
- C** Collar for beam cord.

FIG. 14.

- A** Body of spring.
- B** Hook for attaching a cord.
- C** Eyelet for attaching to hooked screw.

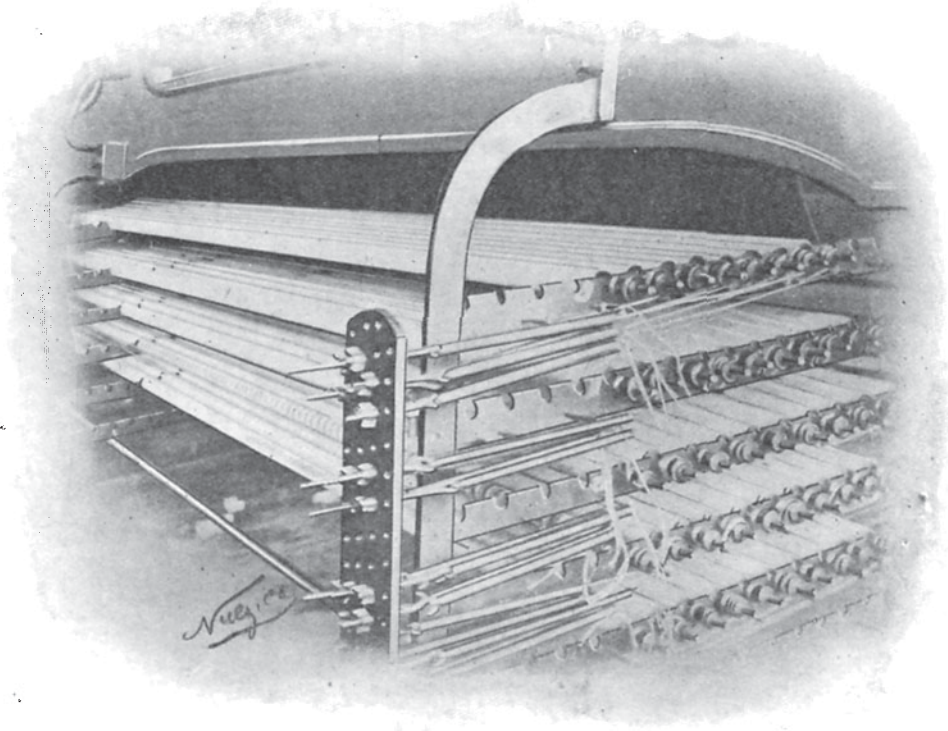

FIG. 15.

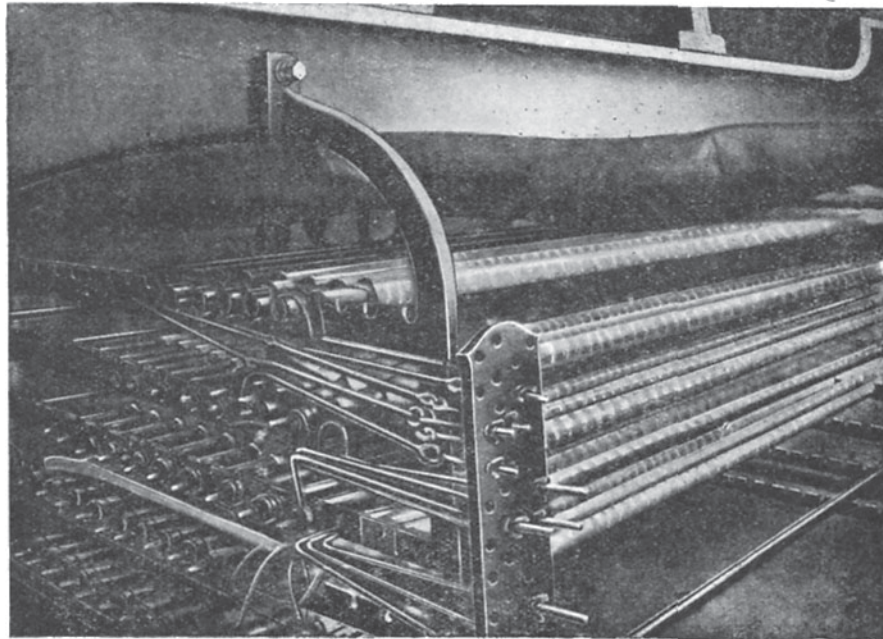

FIG. 16.

THE JACQUARD.

The Jacquard machine is the indispensable complement to the Lever's Machine, to enable it to produce a variety of motifs in the same pattern, either in allovers, breadths, or upon the whole width of the machine, as, without the Jacquard, it could only produce a tissue of plain, Grecian or fancy nets.

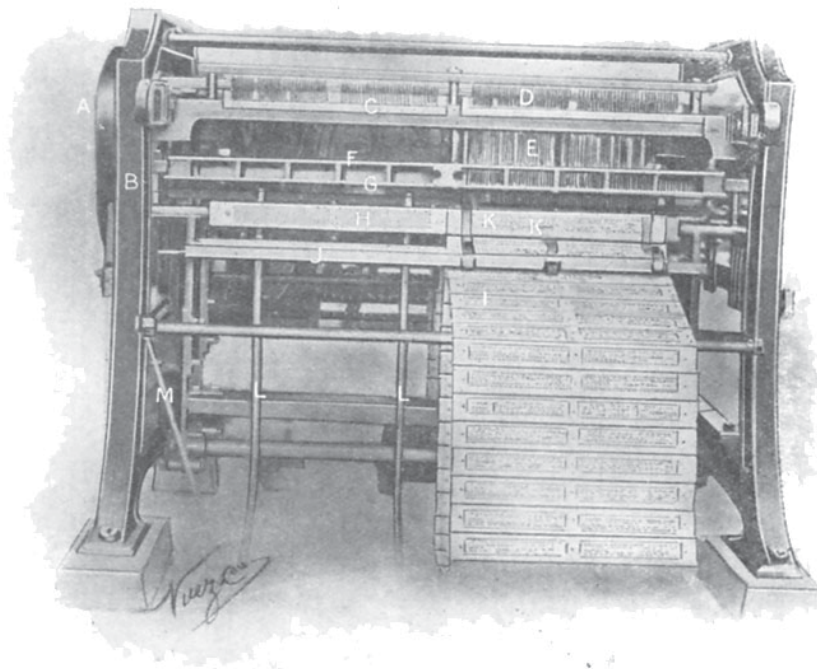

FIG. 17.—JACQUARD, FRONT VIEW.

DESCRIPTION.

A Slides.	H Cylinder.
B Carcass or standards.	I Punched cards.
C Box (or lever) sleys.	J Cross bar on which the card springs are adapted.
D Boxes (or levers).	K Springs.
E Droppers.	L Jacquard card arms or cradle.
F Square hole dropper sleys.	M Bar wrench for setting the bars.
G Round hole dropper sleys.	

In the Jacquard system each bar is hooked on a pull bit and each pull bit on to a draw bolt, that is adapted to the dropper box (or lever)

which by the agency of droppers moves the bar, consequently the threads, from carriage to carriage at each motion of the machine by means of which the net is made and the motifs embroidered on the net.

The Jacquard system has undergone many transformations since it was first adapted to the lace machine. The Jacquard in general use and acknowledged to be the best and least complicated is the spring dropper Jacquard for, except the Manchester or string dropper Jacquard, so called because the droppers are held at the right height in the dropper boxes by strings. The spring dropper Jacquard is the only double motion Jacquard in general use, the single motion Jacquards requiring a system of springs or other mechanical pressing devices to hold the bars in position during the change of motion.

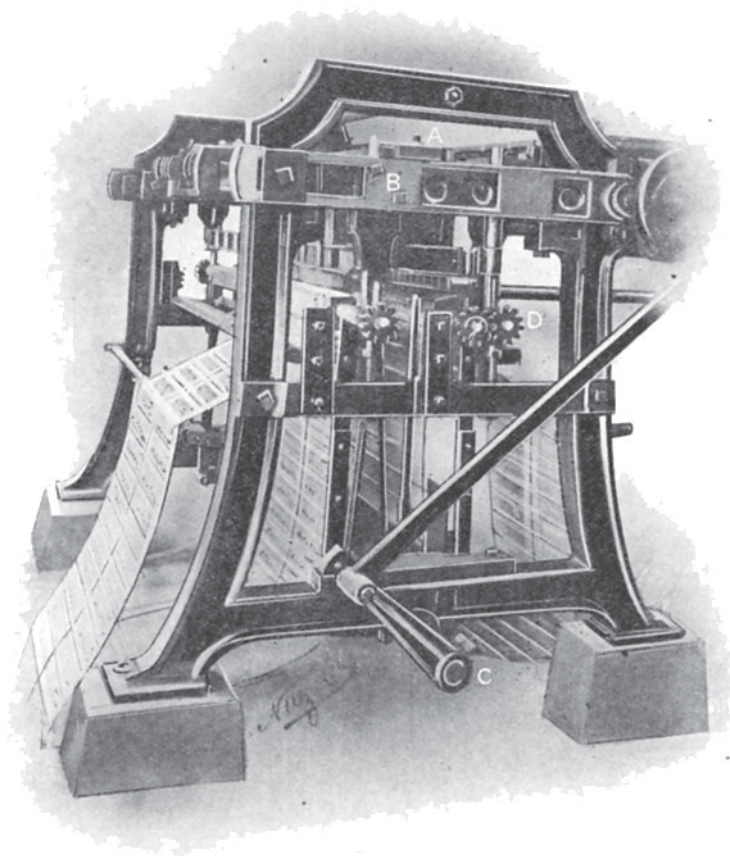

FIG. 18.—JACQUARD, SIDE VIEW.

DESCRIPTION.

- | | |
|-------------------------------|---|
| A Driving blade. | C Cylinder rocking shaft and levers. |
| B Driving blade slide. | D Cylinder racks or gears. |

This system is now used in the Martyn Jacquard.

The Spring Jacquard having two movements (or motions) is consequently obliged to have a double set of cylinders on which to place the cards so that they can actuate the droppers motion by motion according to the holes punched or blank in the cards.

In this system when all the holes are punched of one division in the width of the card, the bar falls to stop or 0. The blanks cause the bar to rise again from 1 to $31\frac{1}{2}$ or even $39\frac{1}{2}$ by the multiplication of droppers.

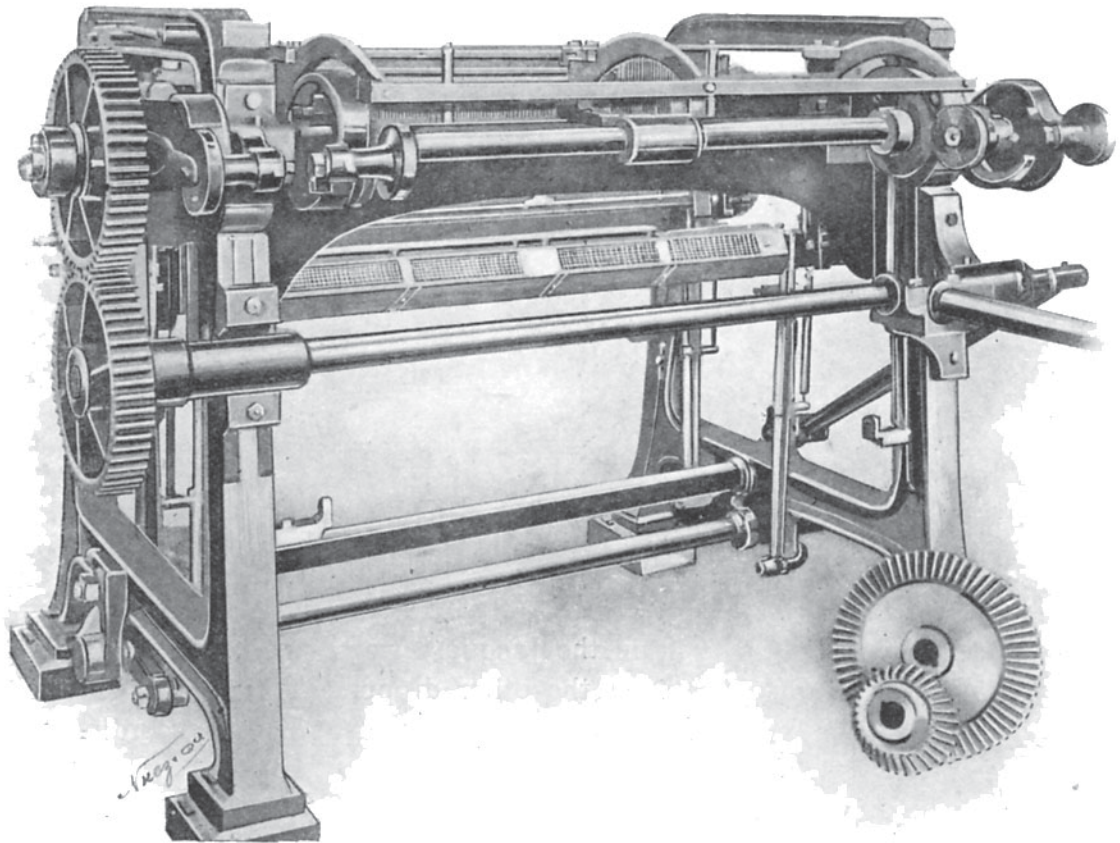

FIG. 19.

JACQUARD BUILT BY THE FIRM OF MALAHIEUDE (BACK VIEW).

DROPPERS.

In the Jacquard the droppers are held in their proper position by 2 transverse plates called dropper sleys which are punched to the same divisions as the box or lever sleys.

The first plate is punched with square holes taking the square body of the droppers, and thus preventing them turning round (Fig. 20).

The second plate is punched with round holes the same diameter as the dropper pins ; the dropper being thus held, presents its pin directly over the centre of the holes punched in the card cylinders and remains at stop.

The dropper sleys are divided in width by 7 or 8 holes (Fig. 20) in which sufficient droppers are placed one after the other to make $31\frac{1}{2}$ or $39\frac{1}{2}$ gaits according to the requirements of the pattern it is intended to produce on the machine.

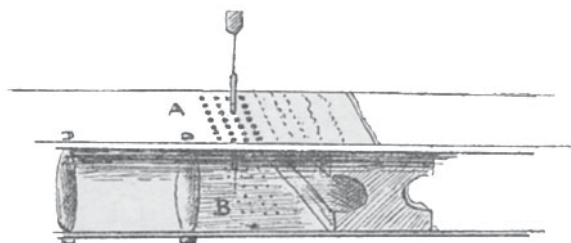

Fig. 20.

In placing the droppers in the Jacquard we begin with the dummy or blank which is longer than the other droppers. This rests on the driving blades and guides the other droppers to be lifted, according to the needs of the pattern.

The second dropper is the one gait which represents the space between two carriages. After the 2, we place the 4, then the bevel 8, after this a straight 8, and then another straight 8, or a 16, gait dropper. This number of droppers will allow us to rise $31\frac{1}{2}$ or $39\frac{1}{2}$ carriages with only 7 holes in the sleys.

The dummy or blank is made with a recess on the front side deep enough to cover the 1 gait dropper, when the 2 gait is at work and the 1 at rest.

The 4 gait dropper is also cut out so as to cover the 2 gait (see Fig. 22), and the bevel 8 is cut out so as to cover the 2 and 4 (see Fig. 23).

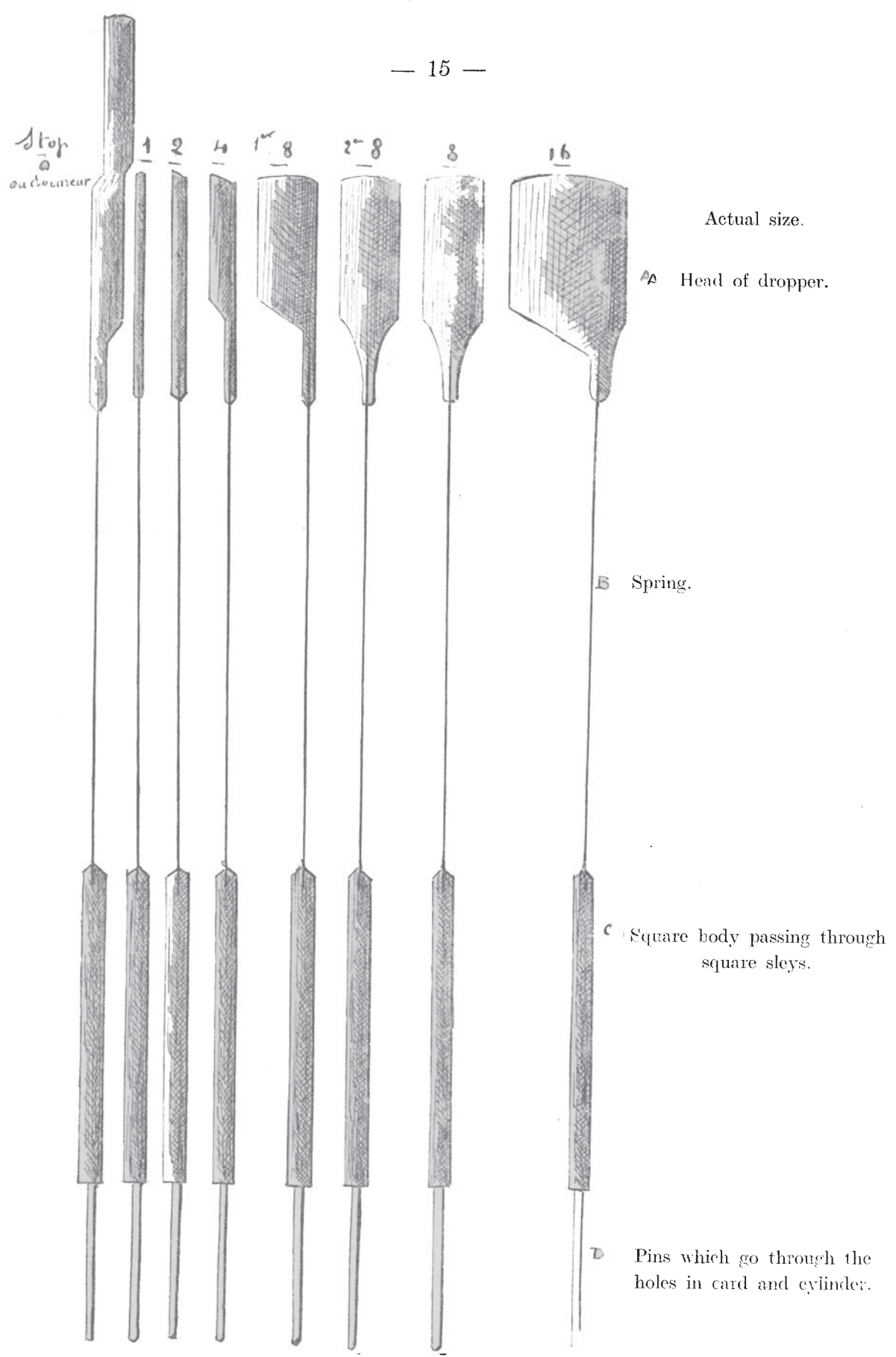

FIG. 21.—POSITION OF DROPPERS AT BLANK OR DEAD STOP.

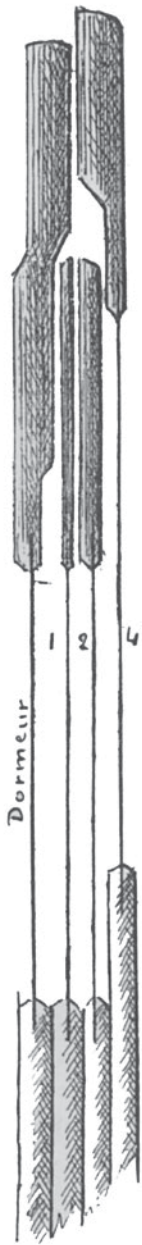

FIG. 22.

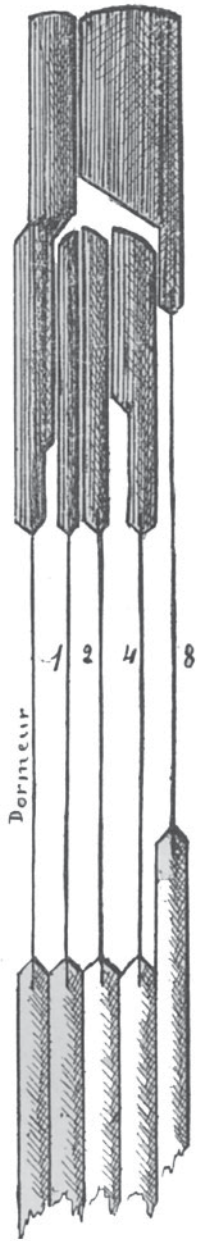

FIG. 23.

We have shown at Fig. 21 the order in which the droppers are placed in the boxes.

We now show (Fig. 22) the position of droppers 1 and 2 when No. 4 gait is up. The bar connected with these droppers will have gone up 4 gaits also.

In Fig. 23 we show 1, 2 and 4 down and the 1st 8 gait up. The bar will now be up 8 gaits.

These 2 examples will suffice to explain how the droppers work.

We show (Fig. 24) the relative positions of droppers and lever.

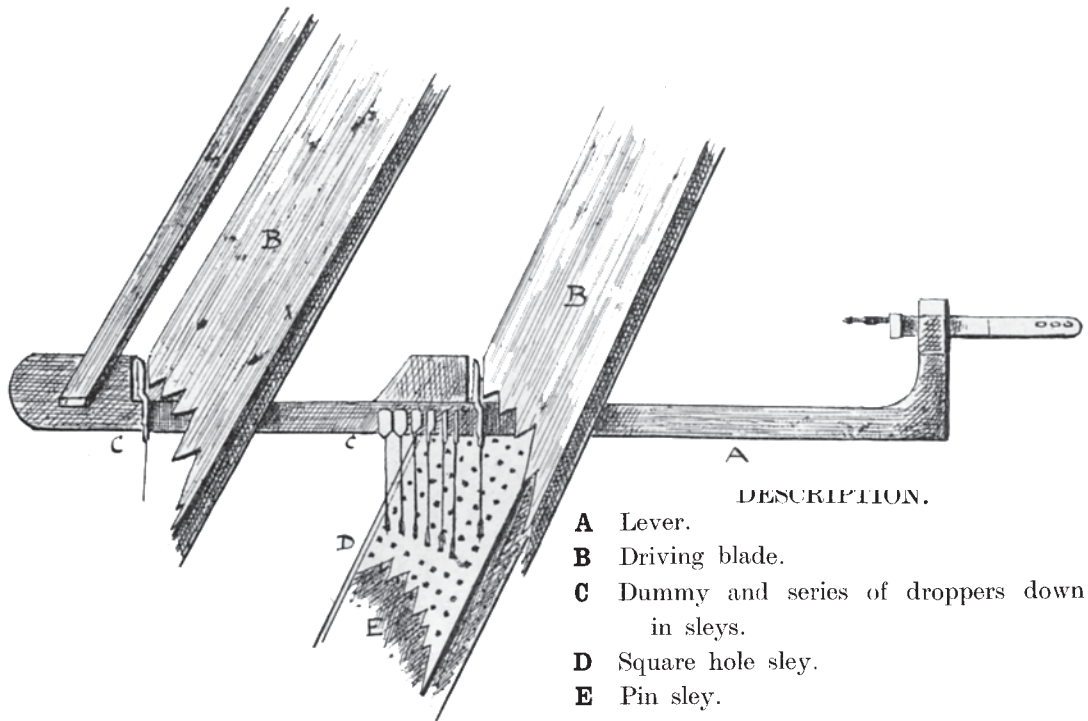

FIG. 24.

DROPPER LEVER.

The levers are placed in sleys cut to same division as the dropper sley.

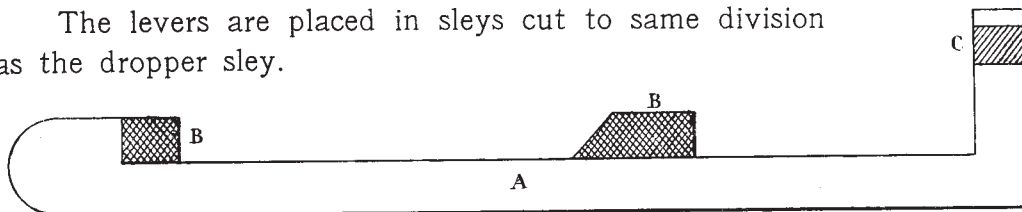

Fig. 25

DESCRIPTION.

- A** Body of lever.
- B** Shoulders upon which the droppers act when up, thus causing the bars to rise.
- C** Slot for draw bolt.

The shoulders upon which the droppers act when up are rivetted to the lever, and are nearly the same thickness as the space between the levers in the sleys.

These shoulders fit close up to the driving blades and hold the bars in the right carriage required by the pattern.

The draw bolt slot is rivetted to the end of the lever and also serves as a dead stop for the draw bolt set screw.

DRAW BOLT.

To set the bar exactly in the centre of the space between 2 carriages, we use a bar wrench belonging to the Jacquard, always loosening the nut before screwing a bar up or down.

Taking a bar up means carrying a thread to the right of a carriage by screwing the draw bolt up.

Letting a bar down means carrying a thread to the left of a carriage by unscrewing the draw bolt screw.

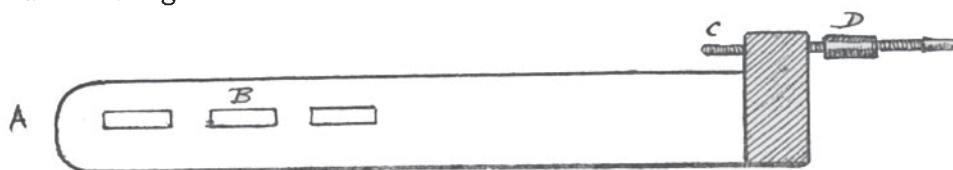

FIG. 26. DRAW BOLT.

DESCRIPTION.

- A** Body of draw bolt passing through the slot in lever.
- B** Holes in which to hook the pull bit.
- C** Screw to set the bar in the space between two carriages.
- D** Nut to fasten screw when in its right position.

When the thread is in the centre of the carriages, fasten the nut so that the bar cannot work loose through the motion of the Jacquard.

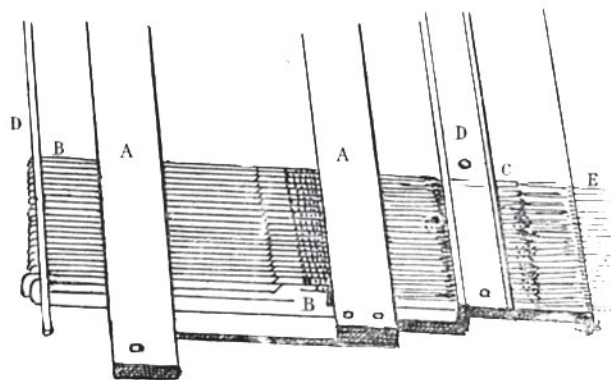

FIG. 27.—TOP (OR BIRD'S EYE) VIEW OF JACQUARD.

DESCRIPTION.

- A** Driving blade.
- B** Lever shoulders.
- C** Draw bolts.
- D** Cover sley on levers.
- E** Pull bits.

PULL BITS.

The pull bit is made of bar steel a little thicker than the thread bars.

It is punched with a certain number of holes (corresponding to the gauge of the machine) 5 carriages apart, or, in some cases, 8 or 10 carriages apart.

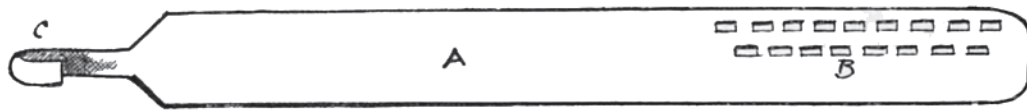

FIG. 28.—PULL BIT.

DESCRIPTION.

- A Steel bar.
- B Holes to hook the Jacquard end of the bar.
- C Hook to hook on to the draw bolt.



FIG. 28 bis.—SPRING HOOK.

DESCRIPTION.

- A Body of spring hook.
- B Hook.
- C Holes for hooking the spring.
- D Spring hooked on spring grid.

Fig. 29 shows the end of a bar hooked on a pull bit, which is itself hooked to the draw bolt.

DESCRIPTION.

- A Cover sley for lever ends.
- B Draw bolt.
- C Pull bit hooked to draw bolt.
- D Bar hooked to pull bit.
- E Screw to set and fasten draw bolt.
- F Jacquard bar sley.

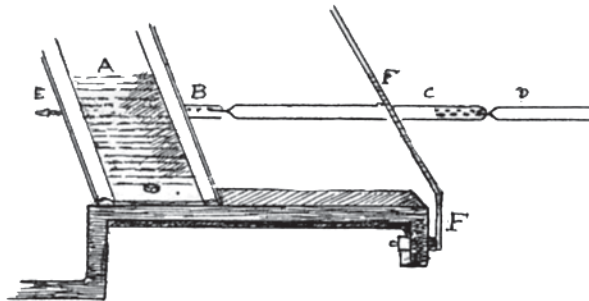

FIG. 29.

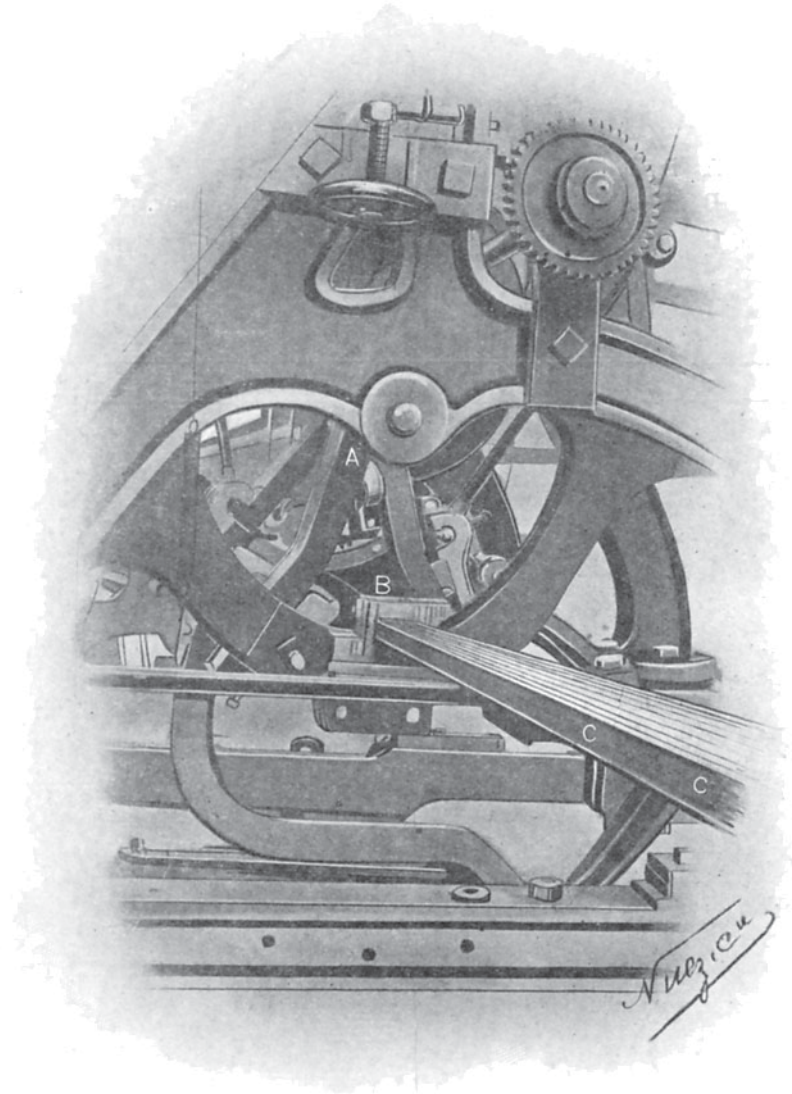

FIG. 30.

We give (Fig. 30) a view of a part of the machine with bars, in bar sley, Jacquard end.

DESCRIPTION.

- A Comb bar hinges.
- B Bar sley.
- C Bars.

SET OUT.

To make Valenciennes the machine has what is called an independent bar set out, that is to say each beam can throw off more or less thread and is independent of the other beams. Therefore it is necessary to have as many beams in the machine as there are threads in the pattern to be made. We understand, by set out, the instructions received from the draughtsman which must be carried out by the workman to reproduce a given article on the machine. The workman receives what is called the sketch which reproduces in a clear manner all the principal parts of the pattern, bobbins, etc. The exact quantity of beams and bars, their numbers, and also the dead stops or gaits where the bars are to be placed in the machine.

SET OUT FOR BEAMS.

Take the maximum number of beams required, divide them by the number of beam arms in the machine, so as to have one division of odd numbers, and the next of even numbers, and so on to the end, put the cords on the odd numbers at the spring end, and on the even numbers at the Jacquard end, and put the cord twice round the collar.

SET OUT FOR BARS.

It is generally the foreman who fixes the bars to the Jacquard and determines where the dead stops for the bars shall start from, in the machine, according to the set out given by the draughtsman.

The bars are hooked in the machine in such a manner as to bring all the bracket slots in one plane, leaving a space of at least $39\frac{1}{2}$ gaits between the bracket pin and the bottom of the slot, so as to avoid spoiling the bars in the event of the bar going up the whole of the $31\frac{1}{2}$ or $39\frac{1}{2}$ gaits.

Be careful in entering the threads through the bars, to always use a fine and flexible hook, so as not to spoil the hole, do not force the hook in the holes otherwise they will cut the threads.

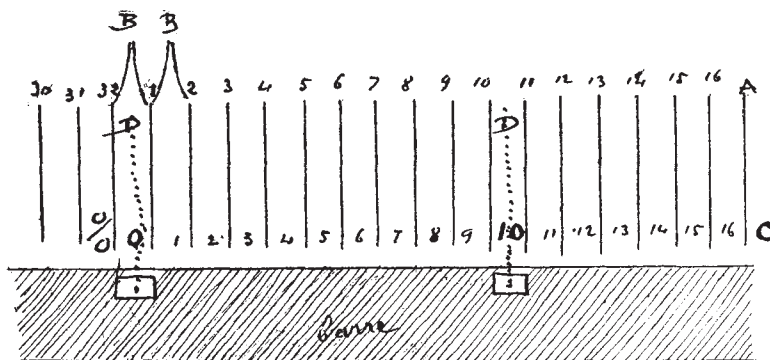

FIG. 31.

DESCRIPTION.

- A Lines representing the carriages in the combs.
- BB Space between 2 carriages.
- C Numbering the carriages for dead stopping the bars.
- D Thread passing through the bar and dead stopped between the carriages

Now, supposing there is no foreman in the shop, and we have a 9 point machine, 144 inches wide on the metal, that is to say, making 144

inches of lace in the width of the machine, we shall find 72 comb leads screwed on the comb bars, each comb lead containing 36 comb blades for holding the carriages.

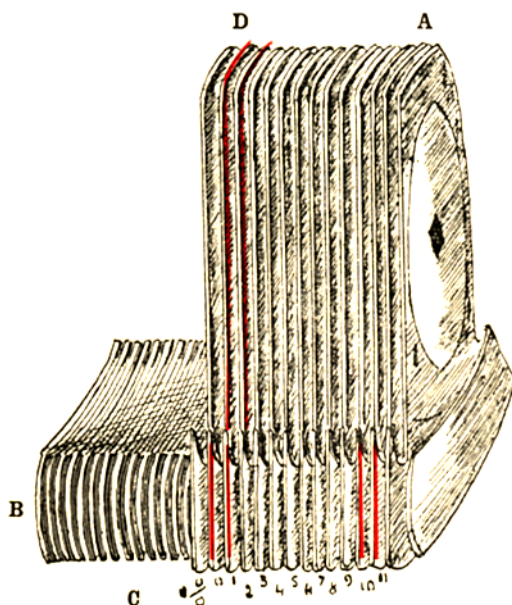

FIG. 32.

DESCRIPTION.

- A Carriages in the combs.
- B Combs.
- C Numbering the carriages.
- D Carriages marked red indicating the dead stop.

We find the gauge of the machine by dividing the number of comb blades in a 2 inch lead by 4, thus, if there are 36 blades in a comb lead, the machine is a 9 point gauge, if 40 blades a 10 point, etc.

Now, if we have to set out this machine to make a 32 carriage breadth, we must first find out how many breadths there will be in 144 inches, and to know the exact place to dead stop the bars below which they cannot go, we

must first multiply the 36 blades which gives the number of carriages in the machine, by $72 \times 36 = 2,592$ carriages.

We now divide these 2,592 carriages by 32 carriages which is the set out we wish to make. This gives us 80 breadths plus 32 carriages. Now as it is necessary to have a selvidge about 16 carriages wide each end of the machine, this will exactly fill our machine.

Blank or dead stop is always found between the first and last carriage of a breadth, therefore, as our first bar is at dead stop, and we have 16 carriages for selvidge, the 1st thread of the 1st bar must be placed between the 16th and 17th carriages from the spring end of the machine. The 2nd bar being at stop 10, we must place it between the 26th and 27th carriage which will be between the 10th and 11th carriage of the breadth.

To make Fig. 31 clear we show the carriages of the first breadth in the combs, leaving the selvidge carriages out (see also Fig. 32).

STOPPING THE BARS.

The dead stop being known we mark the two carriages either red or white so as to make no mistake in setting the threads (see Fig. 31 and 32). We also mark every 10 carriages according to the width of the breadth, or set out, then carefully place the threads in their proper stops and in the middle of the carriages.

Example: No. 1 bar marked at O is placed between the last carriage of the breadth at the left hand and the first carriage of the breadth at the right hand. No. 2 bar marked at 10 is placed between the 10th and 11th carriages of the breadth.

When the first beam has been threaded in the bar, fasten up the threads and be careful to see if any threads have been missed out, or wrongly threaded before threading another beam, as an error at this point would cause a great loss of time afterwards to correct it. When all the threads are threaded in the bars, take a few breadths at a time and fasten them to pins pricked into the sewing on cloth of the roller.

When all the beams are in the beam arms, and threaded through the sleys and bars, smoothed up, and fastened to the lace roller, see that all the cords are on the beam collars and approximately weighted by the springs, then turn on the lace roller a little to further straighten out the threads. Then the carriages can be put in the machine and the bars stopped according to the draughtsman's instructions.

BRACKETS.

When the brackets have been placed at the right height to hold the bars straight in the length of the machine, they must be moved up or down until the pin is below (to the left of) a thread placed one gait below stop.

Then see that there is sufficient slot below the pin to enable the bar to rise at least $31\frac{1}{2}$ or $39\frac{1}{2}$ gaits, so as to avoid all risk of accident should the bar rise to the full limit of the droppers. In Fig. 33, we give a bracket in its right position, as seen from the front of the machine.

DESCRIPTION.

- A Bracket stem.
- B Bracket pin through the bar.
- C Thread bar.
- D Bar slot.
- E Thread holes.
- F Combs.
- G Carriages in the combs.
- H Thread through the bar and set at dead stop.

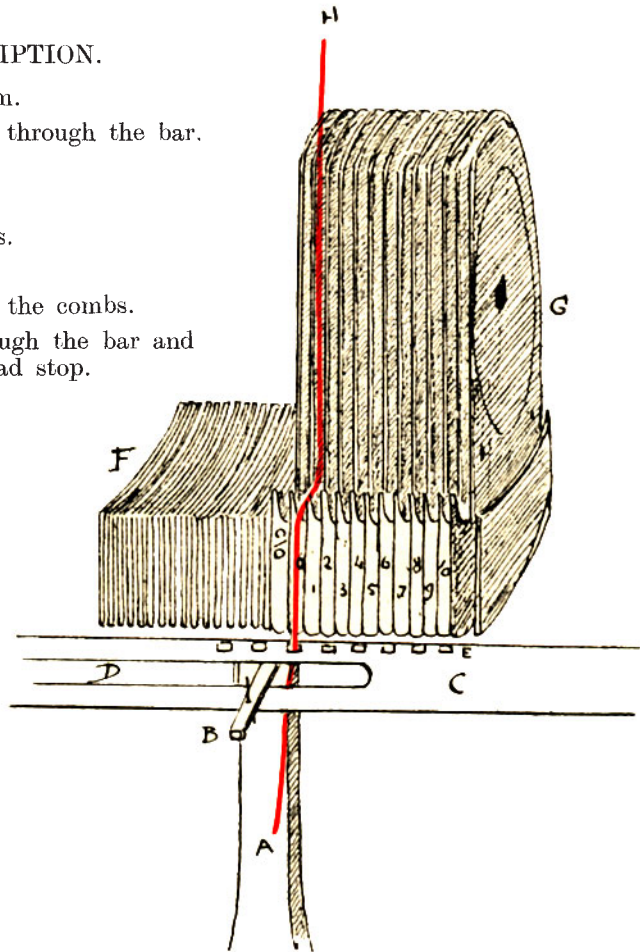

FIG. 33.

SET OUT FOR SLEYS.

Knowing how many beams there are to be in the machine, and how many in each tier (or beam arm), we must now find how wide we can prick the sley, so that the threads will pass easily and naturally through the bars without breaking. If they are sleyed too narrow they nip the bars together, which wears the threads out at the top of the bar holes, and if they are sleyed too wide they open the bars fanwise and cause them to cut.

The best and most practical way of determining the right width of the sley, is to fasten two threads to a pin pricked into the lace roller cloth, and bring them down to the sleys between the two comb bars (see G. Fig. 36). Now stretch them, one to the back and the other to the front, being careful to leave at least 1 millimetre of clearance between the threads and the comb bar. We shall now know exactly how wide to sley the threads, and, according to the number of threads to be run in, we shall set out in 2 or 4 divisions.

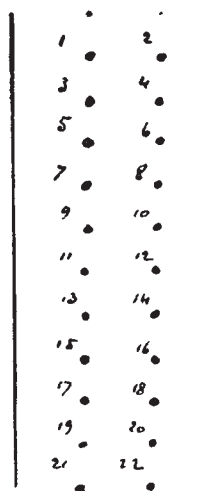

Fig. 34

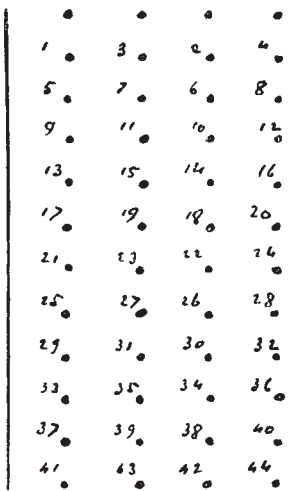

Fig. 35

Fig. 34 gives a set out on 2 divisions, and Fig. 35 gives a set out on 4 divisions.

METHOD OF FINDING THE WIDTH OF THE SLEYS.

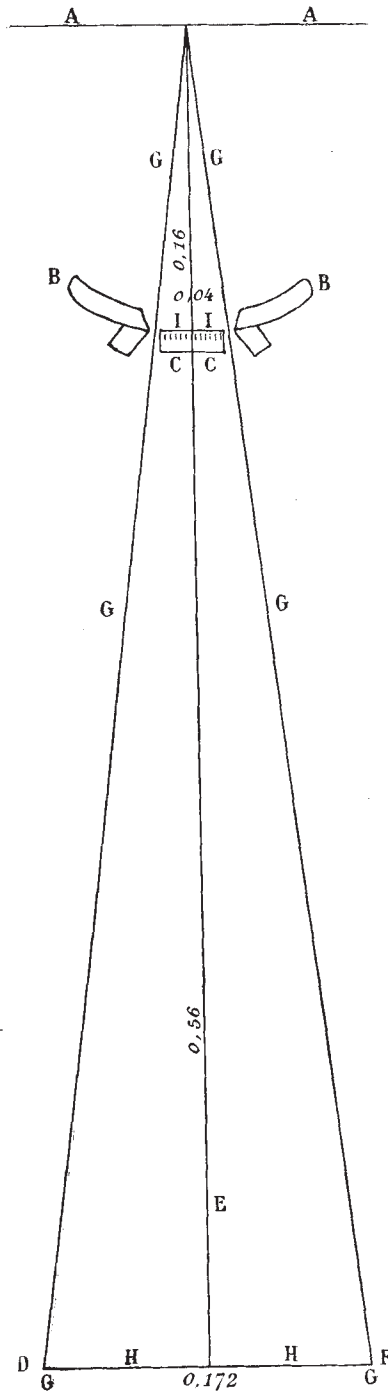

Fig. 36

(Fig. 36 is one quarter full size). Assuming that the distance between the comb bar strips and the points is 0.16 centimetres, and that the sleys are stretched 0.56 centimetres below the point bars, and the distance between the comb bars 0.04 centimetres, if our bars are 3 to the millimetre in thickness, we can safely work 120 bars in the machine without fear of accident.

As by this method all the threads will come naturally to the bars, without forcing either to the front, or to the back, and thus avoid friction and wear of the yarns employed. The width obtained for sleying 120 beams is 17 centimetres 2 millimetres. For this number of beams we advise setting out in 4 divisions (Fig. 35), that is to say, with 2 divisions of odd threads, and 2 divisions of even threads. If we were to put this number of beams in 2 divisions only, 0.17 centimetres in width, the holes would be so close to each other that the threads would cot and twist together, through the knots, and lint that is on the yarn. When quite ready for running the first beam in, place it in the beam arms, and draw off a certain length in 2 meshes, for each half of the beam. Place these meshes on the floor in a convenient position for running through the rod sleys, or eyeletting, then through the top sleys, to the divisions of the set out.

DESCRIPTION.

- A Face (or centre) plate.
- B Comb bars.
- C Thread bars.
- D Spot where to prick the hole for No. 1 beam on sley.
- E Perpendicular from the face-plate to sleys giving the distance between the point bars and the sleys.
- F Spot where to prick the hole for the last beam of set out.
- G Represents the stretched threads which give the width of the sley.
- H Sley.
- I Level of comb bar strips.

GETTING ON (THE CARRIAGES.)

It is of the utmost importance to take the greatest possible care in getting in the carriages, that is, putting them in the machine when threaded, if the machine is to go well and make good work. In looking over the bobbins before threading, carefully take out all the wide ones, and especially any that may be damaged, as the wide ones cut the threads out, and the damaged ones may come out of the carriages while the machine is in motion, and cause a serious accident.

When the carriages are threaded, see that the springs hold the bobbins straight in the carriages so that the bobbin does not exceed the carriage either to the right or to the left. Remove those that are doubtful, then look the bobbins over again and verify the springs.

In shaking the bobbins, carefully separate, and put together the tight, medium, and slack. The slack ones are generally used for the front of the pattern, as they give a more regular scallop and band, than tight ones, and break less threads. We explain below how to place the slack, medium, and tight bobbins, for a 32 carriage width in a Valenciennes set out.

No. 1 bobbin, which is generally the separation, is usually unbleached cotton of a coarser count than the others, should be tight. Sometimes this bobbin has to be passed round the branch (or breast) of the carriage before threading to tighten it. In other cases where there are several holes in the carriage top, it is threaded through three holes for the same reason.

No. 2 carriage should be medium tight for the corder.

Nos. 3 and 4, which we call band bobbins, should be slack.

Nos. 5 to 31 carriages, destined to make the net, should be medium tight.

No. 32, which we call the weaver bobbin, should be slack.

METHOD OF SHAKING (or regulating the bobbins).

The bobbins being threaded, take a convenient number of carriages in the left hand, unite all the threads together in a mesh in the right hand, then hold the carriages up by these threads, letting them hang, then shake them gently. The slack bobbins will run down and can be removed, then the medium slack, leaving the tight ones in the hand. Then classify them on the table in 3 rows, the slack to the left, the medium in the middle, and the tight to the right.

This method gives the twisthand every facility for placing the carriages in the machine breadth, by breadth, according to the requirements of the pattern.

We cannot insist too much on the importance of thus regulating the carriages. If a slack bobbin is placed in the net, it makes a wide hole of net, or a tight bobbin will make a narrow hole, and thus make irregular and faulty work.

When all the carriages are in, make several motions of the machine before putting on the cards.

CARDS.

When all the bars are carefully set in their stops according to the set out, put the comb bar down and turn over, to liberate the front cylinder of the Jacquard, on which we now place the odd number cards.

Before putting cards on, see that the cylinders are well oiled and work freely, and that no holes are stopped up with punching bits, etc.

Then tie the cards on. Be careful when tying the first card to the last to keep the same space between them as there is between the other cards so that they will follow regularly on to the cylinder pegs. After they are tied run the pattern round, on the cylinders, and see that there are no holes stopped up with bits, or pieces of lacing tape, etc., and that the cards are properly laced and in the right order, to avoid if possible, all accidents such as making a line across the tissue, breaking out a number of threads, or even causing a smash in the machine.

The cards, as they leave the cylinders motion by motion, slide down the card arms by means of wires tied across the cards at regular intervals. These wires are a little longer than the cards and rest upon the card arms.

Keep the card arms very clean.

When No. 1 card is up on the cylinder and its holes correspond with the holes in the cylinder and the dropper needles, make a motion very slowly then turn the catch bar over, and push the carriages carefully down by hand. So as to avoid all accident, do the same with No. 2 card, then go on slowly until the cards have gone completely round, and the pattern will be out.

WORM.

The worm controls the roller on which the lace is rolled as it leaves the points.

By changing the toothed wheels adapted to the worm, the lace can be made stiffer or slacker.

Generally, the worm is fitted to the machine standard, Jacquard end. (For description see Fig. 37).

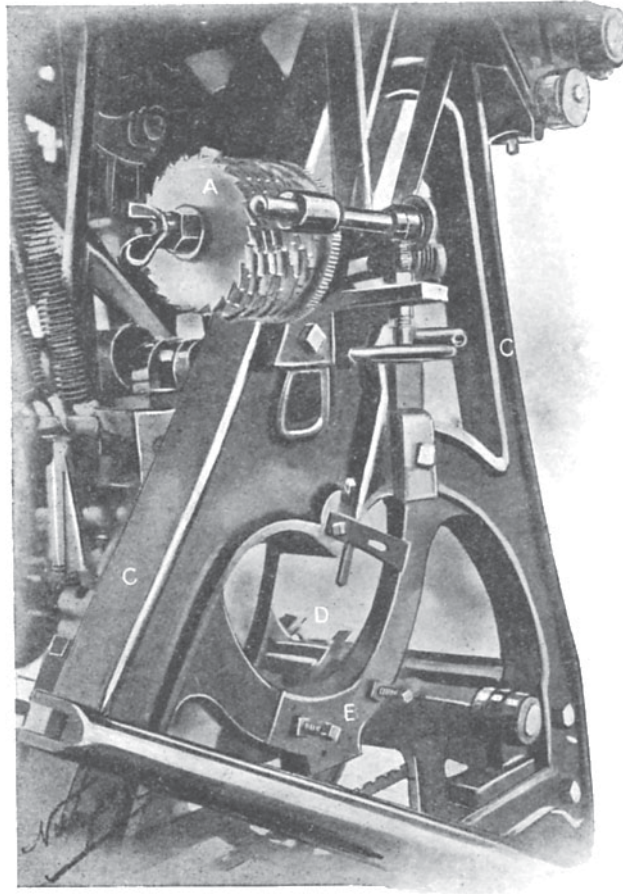

FIG. 37.—VIEW OF THE MACHINE STANDARD,
JACQUARD END, WITHOUT BARS OR BAR SLEYS.

DESCRIPTION.

- A** Toothed wheels, called quality wheels, adapted to the worm axle.
- C** Machine standard.
- D** Space where the bars pass into the machine.
- E** Position of bar sley.

SETTING THE CIRCLE.

One of the most important matters for a lace manufacturer, is to have his machine well set.

It sometimes happens that, when a machine has been working for some time, it gets out of order, and the circle requires setting again. There are different ways of doing this; we will give the two methods generally adopted by the best inside men.

FIRST METHOD.

We trace on paper a horizontal corresponding to a string stretched between the centre of the hinges to which the comb and landing bars are screwed, called the centre thread (see A, Fig. 38). From the middle of this line we draw a perpendicular; now, from the top of this perpendicular, with the aid of compasses, we trace arcs of a circle about twice the length of a carriage and about 1 or 2 millimetres apart.

We now take a carriage of the Machine and hold it perpendicularly so as to adapt the bottom of the carriage (the curved part) to the arcs of the circles we have traced, and move it until we find the one which coincides with it best. This arc is the circle of the machine. This coincidence can never be perfect because each end of the carriage has a lead of 1 to 2 millimetres from each end, to enable the carriage to safely enter the combs and prevent what is called wrong gaiting, or even smashing.

The distance between the line A and the arc of the circle J, represents the distance at which the comb bars must be put to insure the machine working well.

SECOND METHOD.

To describe this method, we make use of a geometrical formulae. To find the lost centre of part of a circumference, we mark 3 points anywhere upon this part of a circumference.

Let us take, for example, Fig. 39. With compasses we trace an arc of any circle from A to B; then we mark 3 points, C, D, E, upon this arc. Now, taking point C, as a centre, with our compasses opened

rather wider than half the distance from C to D, we describe other arcs above and below the line A B. We now do exactly the same from point D. We have now described 4 arcs forming points of intersection at F F.

We repeat this operation from points D and E after opening our compasses a little wider. We now trace very carefully 2 lines through the points of intersection F F and G G until they meet at H, which point is the centre of the arc A B that we are seeking for.

Now, if instead of tracing an arc with compasses, we take a carriage from the machine of which we wish to find the centre, and trace an arc from the bottom of the carriage ; not using, for this purpose, the extreme ends of the carriage, because the extreme ends of the carriage bottoms are slightly cut away ; and repeat the operation described above we shall find in the point H the centre to which we must set the machine.

DESCRIPTION.

- A Centre thread.
- B Perpendicular.
- C Experimental arcs.
- D Comb blades.
- E Comb tails cast into the leads.
- F Comb leads.
- G Comb lead screw.
- H Comb bar strips.
- I Comb bars.
- J Arc that exactly fits carriage bottom.
- K Well of machine.

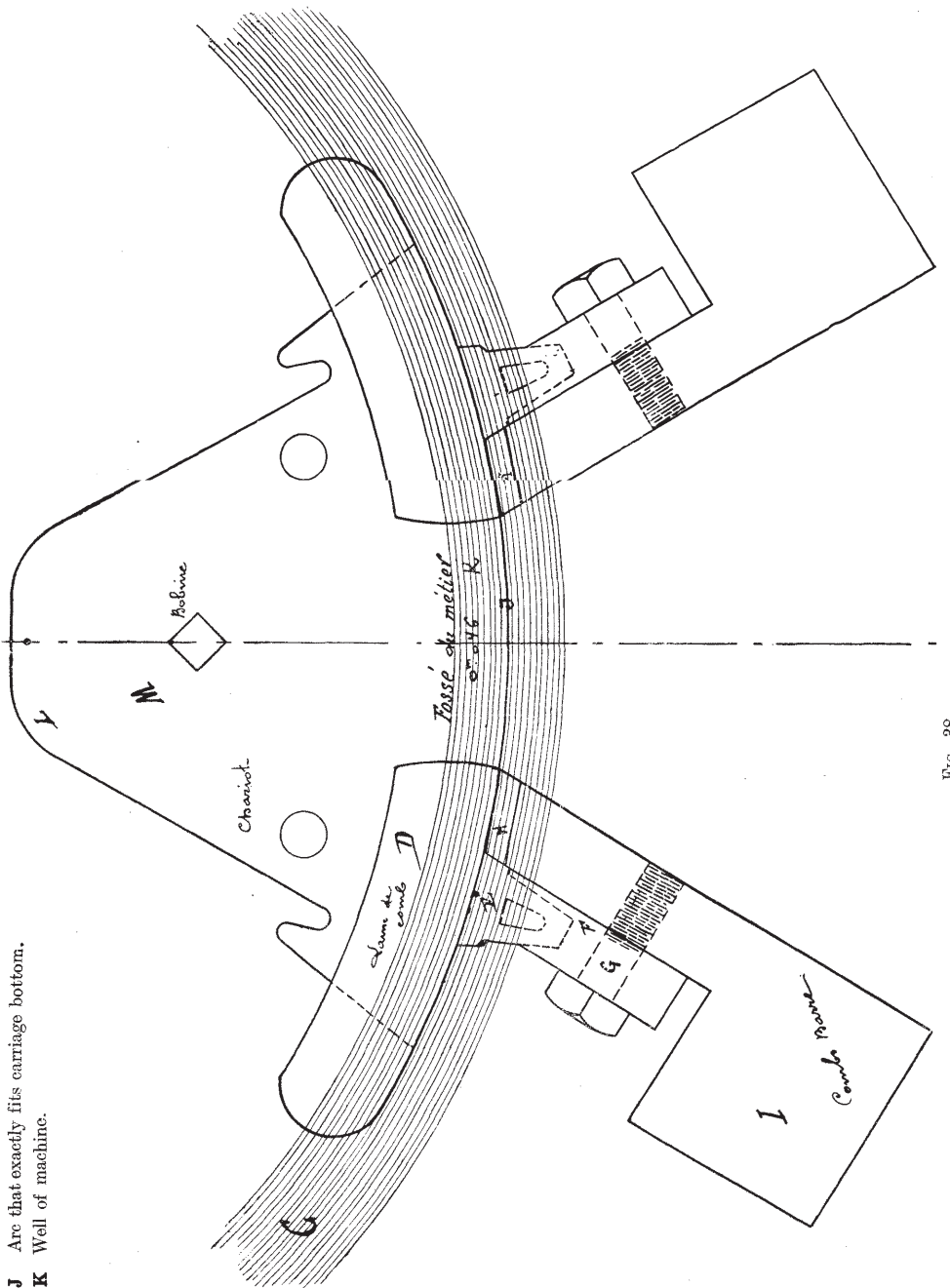

FIG. 38

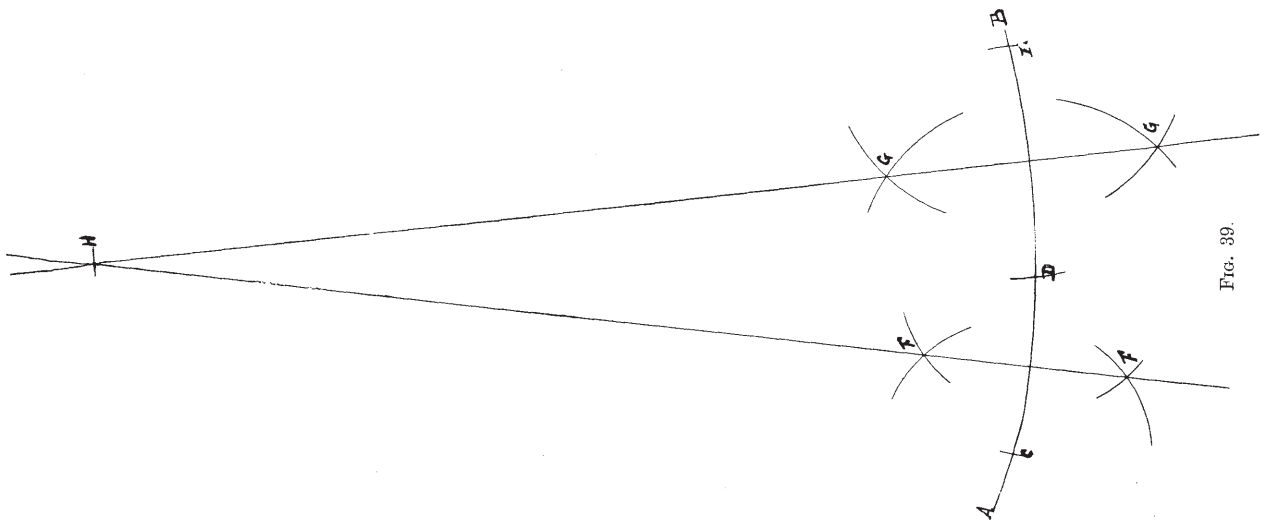

FIG. 39.

NIPPING TACKLE.

We call a nipper, or presser, a cord attached to a dropper lever and connected to a special collar screwed to a beam axle. By means of levers or pulleys it can be used either to put extra weight on a beam in any part of the pattern, or to take weight off. It is sometimes attached to the beam spring instead of to the special collar referred to. When making point d'esprit spots, we use counter springs on the opposite collar (spring end of the machine) to regulate the beam when the nipping tackle has taken all the weight off a beam. The nips can be arranged in different ways either to nip on stop, or on 24, or 31.

IMPORTANT RECOMMENDATION.

It often happens that bars tie in, in various parts of the machine, and that threads break when the cause seems difficult to locate.

One of the most important points for the workman, is to see that the droppers are dead to gauge, and that the bar has not been pulled out. It sometimes happens that when a pattern works well, and another is put on without changing the dead stops, a bar will begin to miss and work wrong. The cause may be that a dropper, not at work in the previous pattern but in use in the second one, is not to gauge. The dropper must be changed as also a lengthened (or pulled out) bar.

It is better to replace such a bar as it is almost impossible to divide the difference, especially in a fine gauge machine.

CONTENTS

OF THE
TWISTHANDS' SCHOOL.

	Page		Page
Preface	III	Pull bits	19
Machine	1	View of bar and pull bit attached to draw bolt	19
Carriage	3	View of bars entering sleys, Jacquard end	20
Bobbin	3	Set out	21
Manipulation	4	Set out for beams	21
Bars	4	Set out for bars	21
View of bar passing through sleys, spring end	5	Set out for dead stops	23
Bar sley B	6	Position of bracket as seen from machine front	24
Bracket	6	Set out for sleys	25
Top sley	7	Method of determining width of sleys	26
Rod sley or eyelet rods	8	Getting the carriages on	27
General view of beams placed in machine... ..	10	Method of regulating the bobbins... ..	28
Jacquard—Front view	11	Cards... ..	28
Jacquard—Side view	12	Worm	29
Jacquard—of the firm of Malahieude	13	View of machine standard, Jacquard end	30
Jacquard—Back View	13	Setting the circle (different methods)	31
Droppers	14	Nipping tackle	35
Position of Lever and Droppers	17	Important recommendation	35
Levers or Dropper Boxes	17		
Draw Bolts	18		
Jacquard—Top View	18		

