 COTTON
MANUFACTURING
PART 2
By E. A. POSSELT

MASON MACHINE WORKS

Taunton, Mass., U. S. A.

COTTON MILL MACHINERY

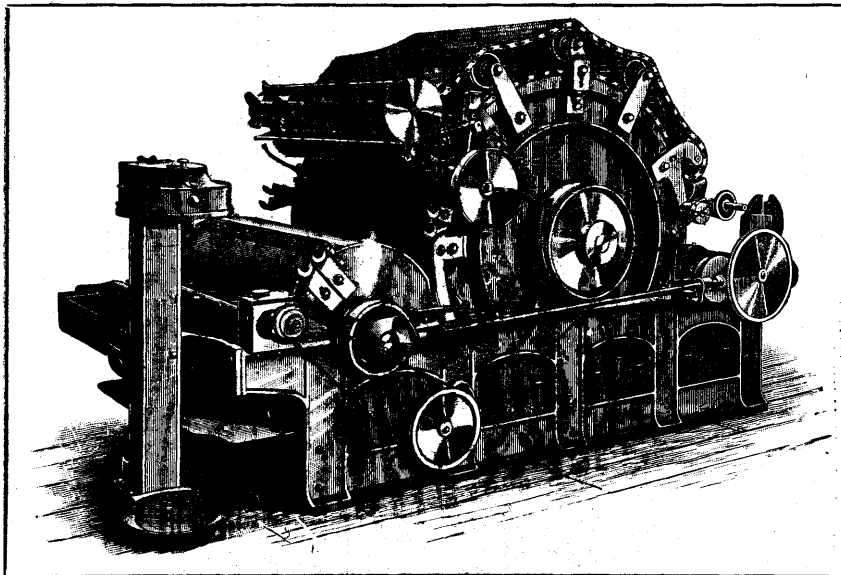

REVOLVING FLAT CARDS,

ALSO

**COMBERS, DRAWING FRAMES, MULES,
RING SPINNING FRAMES,**

**PLAIN AND FANCY LOOMS
AND DOBBIES.**

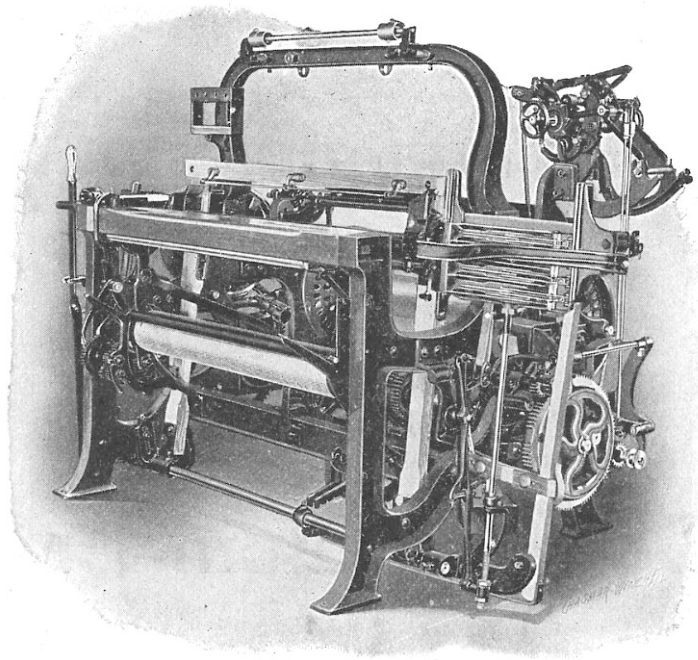

CROMPTON & KNOWLES GINGHAM LOOM

BUYERS of Plain and Fancy Looms will appreciate the advantages of being able to purchase everything they require in the line of WEAVING MACHINERY from one company. We build all kinds

Send for Catalogues

**CROMPTON & KNOWLES
LOOM WORKS**

Worcester, Mass. Prov., R. I. Phila., Pa.

THE
Whitin Machine Works

WHITINSVILLE, MASS.

BUILDERS OF

Cotton Machinery

CARDS

RAILWAY HEADS

COMBING MACHINERY

DRAWING FRAMES

SPINNING FRAMES

SPOOLERS

TWISTERS

REELS

LONG CHAIN QUILLERS

LOOMS

Telegraphic Address: "PLATTS, OLDHAM."

PLATT BROTHERS & CO. LIMITED,

HARTFORD IRON WORKS, OLDHAM, ENGLAND.

MAKERS OF MACHINERY IN GREAT VARIETY, FOR
OPENING, CARDING, COMBING, PREPARING, SPINNING, DOUBLING AND WEAVING
Cotton, Wool, Worsted, Silk Waste, Asbestos, &c.
Also **Seed Cotton Openers and Gins** for long or short stapled cottons.

HOPPER BALE BREAKER or Improved Cotton Pulling Machine, working in combination with Hopper Feeding Machine, **CRIGHTON OPENER CYLINDER PART**, and **EXHAUST OPENER & LAP MACHINE**.

WASTE OPENING & FEEDING MACHINE, to work in connection with Exhaust Opener & Lap Machine.

Improved Self Acting Willow.

SCUTCHERS with all latest improvements.

PATENT REVOLVING SELF STRIPPING FLAT CARDING ENGINE OF VARIOUS SECTIONS, 72 Flats 2" wide, 90 Flats 1 $\frac{5}{8}$ " wide, and 106 Flats 1 $\frac{3}{8}$ " wide.

Card Grinding Machines. Patent Apparatus for grinding the flats from their working surfaces.

SLIVER LAP, & RIBBON LAP MACHINES FOR HEILMANN'S COTTON COMBER.

PATENT COMBING MACHINES FOR COTTON (HEILMANN'S SYSTEM), 6, 8, or 10 boxes, 8", 10 $\frac{1}{2}$ ", 11" or 12" laps.

DRAWING, SLUBBING, INTERMEDIATE, & ROVING FRAMES for Cotton, Worsted, &c., with single or duplex cones.

PATENT SELF ACTING MULES, FOR COARSE, MEDIUM, OR FINE YARNS. Ring & Flyer Spinning & Doubling Machines for Cotton, Wool, Worsted, Silk Waste, &c.

Patent Reels & Bundling Presses.

LOOMS & necessary Preparing Machines for all descriptions of Plain & Fancy Cloths.

Breaking up Machinery for Hard Waste.

MACHINERY for Carding, Preparing, & Spinning Cotton Waste, Vigogne, & Barchant yarns.

Chapon's Patent Cup Spinning Machine for Cotton, Wool, and Waste.

IMPROVED MACHINERY FOR CARDING, COMBING, PREPARING, & SPINNING WORSTED ON BOTH THE FRENCH & ENGLISH OR BRADFORD SYSTEMS. (WITH CONE INTERMEDIATE AND ROVING IF REQUIRED.)

WOOL Opening, Carding, & Spinning Machinery. Tape & other systems of Condensers. Brown's Patent Card Roller arrangement.

Patent Machinery for Carding, Preparing, & Spinning Short Silk Waste.

MACHINERY for Pounding or Breaking, Opening, Carding, Spinning, Doubling, & Weaving Asbestos.

Patent Brick Making Machinery.

Highest Awards of Merit at all Exhibitions for TEXTILE MACHINERY, including "GRAND PRIX and GOLD MEDAL," PARIS, 1900, and "GRAND PRIZE," ST. LOUIS, 1904.

AMERICAN AGENTS:

MR. EVAN ARTHUR LEIGH, 232 Summer Street, Boston, Mass.
THE CAMERON & BARKLEY CO., Charleston, S. C., for Cotton Ginning Machinery.

We are
prepared
to prove that
Peroxide of
Sodium for

Bleaching
animal & vegetable
fibres
or their mixtures
is the best.

Roesler & Haslach
Chemical Co.
New York

LOOMS

For Weaving

Ginghams and other fancy
Cottons.

Write for further information

Crompton-Thayer Loom Co.

Worcester, Mass.

AMERICAN DYEWOOD COMPANY

Extracts of Logwood
Fustic, Cutchine, etc.

Logwood Crystals
Haematinates of all kinds
and grades

Cotton, Wool and Silk
Extracts

Cut Logwood and
other Dyewoods

Tetrazo Colors

(Direct or Substantive)
For Cotton Dyeing

Tetrazo Sulphur Colors

For Shades Fast to Milling
Light and Cross Dyeing

Tetrazode Colors

(Diazotised and Developed)

Tetranil Colors

(After-treated with Metal-
lic Salts)

Acid Colors for Wool
Russet Colors for Leather
Specialties for All Purposes

PHILADELPHIA NEW YORK BOSTON HAMILTON

Saco and Pettee Machine Shops,
Cotton Machinery

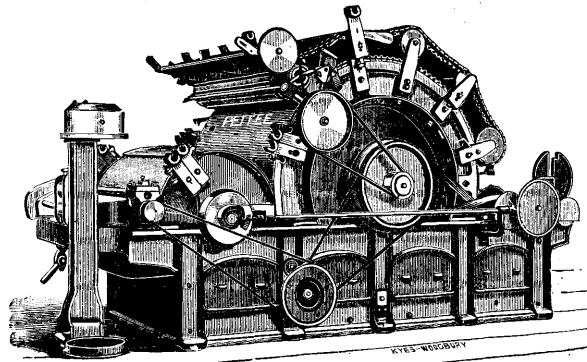

Shops at **Newton Upper Falls, Mass.**
Biddeford, Maine.

Southern Agent, **A. H. Washburn, Charlotte, N. C.**

DRAPER COMPANY

Manufactures improved cotton machinery

for Spinning
Spooling
Warping
Twisting
and Weaving

also Banding Machines

and Chain Dyeing Apparatus

at Hopedale, Mass.

We have full catalogs which
we are pleased to send

Write us for further information

DRAPER COMPANY

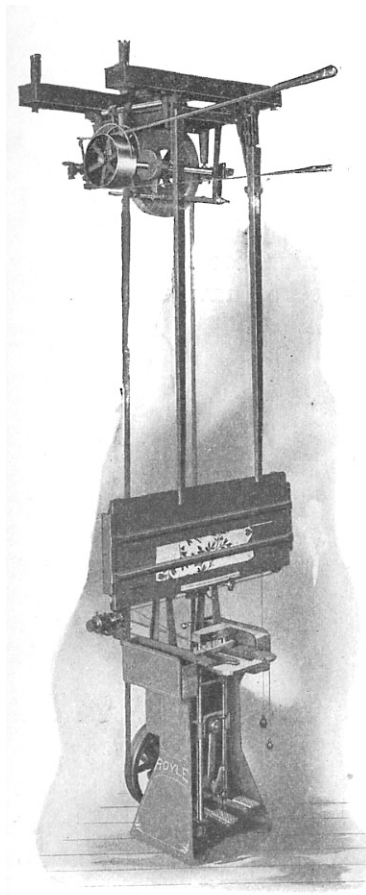

A Decided Acquisition

to the already admirable features of our Power Piano Machine, is the overhead countershaft. By this speed controller you can regulate the cutting movement of the machine to suit the variations of the design. Take our advice and write for particulars of both the machine and this last improvement.

We have Lacers and Repeaters also that complete a full line of Jacquard Card Cutting Machinery. To those interested in such

work there is a golden opportunity here to run this department in your factory on the most economic lines.

An Illustrated Catalogue is waiting for your address

JOHN ROYLE & SONS

PATERSON, N. J., U. S. A.

Manufacturers should look up the advantages of the

METALLIC DRAWING ROLL

Over the leather system before placing orders for new machinery, or if contemplating an increase in production, have them applied to their old machinery.

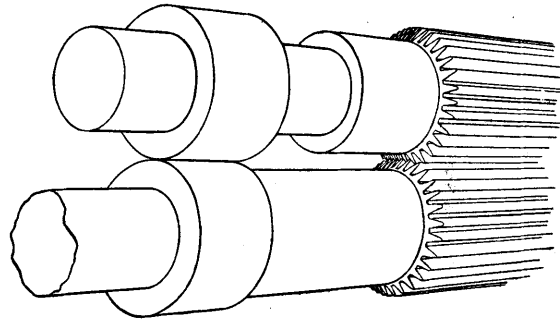

25 to 33 per cent more Production Guaranteed

SAVES

Roll Covering
Varnishing
Floor Space

Power
Waste and
Wear

One-third Less Weight Required

RUNS SUCCESSFULLY ON

Railway Heads
Sliver Lap
Ribbon Lap
Monfort Combers

Drawing Frames,
mechanical or
electric stop motion
Slubbers

Intermediate Roving

Write for Points Claimed, also Prices and Particulars, to

The METALLIC DRAWING ROLL CO.

INDIAN ORCHARD, MASS.

HOWARD & BULLOUGH
American Machine Company, Ltd.
Pawtucket, R. I.

C. E. RILEY, Treas.

COTTON MACHINERY

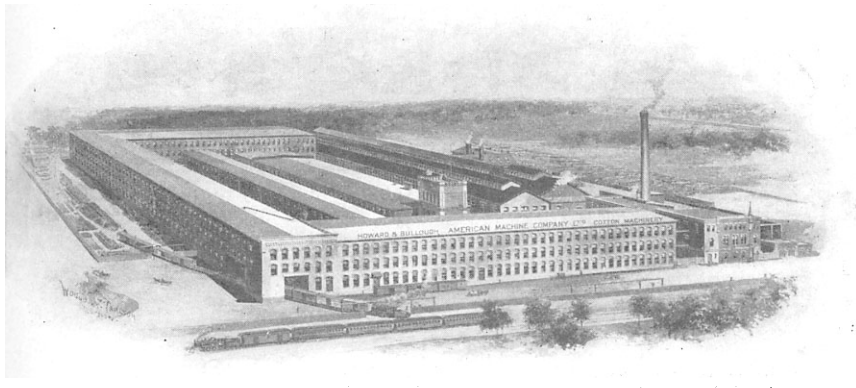

Hopper Bale Openers

Feeders

Self Feeding Openers

Breaker, Intermediate and

Finisher Lappers

Revolving Flat Cards

Drawing Frames

Slubbing, Intermediate and

Roving Frames

New Pattern Spinning Frames

Improved Twisters

Cone Winders

Warpers and Slashers

BOSTON OFFICE:
65 Franklin St.

Southern Offices:
814-815 Empire Bldg.
ATLANTA, GA.

WE INVITE YOUR INVESTIGATION and COMPARISON

CHENEY BROS.,

SILK MANUFACTURERS,

South Manchester and Hartford, Conn.

SALESROOMS:

NEW YORK, 477 Broome Street.

BOSTON, 79 Chauncy Street.

CHICAGO, 239 Fifth Avenue.

PHILADELPHIA, 929 Chestnut Street.

ALL KINDS OF

Spun Silk Yarns,

In the Gray, Dyed or Printed,

ALL KINDS OF

ORGANZINES, TRAMS and SINGLES,

In the Gum or Dyed, on Spools, or on Cones, Warped or in the Hank,

16 OUNCES TO THE POUND PURE SILK.

FAST COLORS WARRANTED.

SPECIAL YARNS made to order for all sorts of SILKS or SILK MIXTURE GOODS

MANUFACTURERS' ORDERS PROMPTLY EXECUTED.

ALL KINDS OF

Knitting Silks, Ribbons and Piece Silks

Used for Trimming Knit Goods.

Cotton Manufacturing

PART 2.

COMBING, DRAWING, ROLLER COVERING AND FLY FRAMES;

Being a Complete Treatise on Modern Processes and Machinery Used in
Connection with these Processes of Cotton Spinning,
Giving also all the Calculations Required.

By

E. A. POSSELT,

CONSULTING EXPERT IN TEXTILE DESIGNING.

Author of "Technology of Textile Design;" "The Jacquard Machine Analyzed and Explained;"
"Structure of Fibres, Yarns and Fabrics;" "Textile Calculations;" "Recent Improvements
in Textile Machinery Relating to Weaving, Parts 1 and 2;" Wool, Cotton,
Silk from Fibre to Finished Fabric;" "Cotton Manufacturing, Part 1;"
Principal of "Posselt's Private School of Textile Design;"
formerly Director of the Philadelphia Textile School.

COMPLETELY ILLUSTRATED.

PRICE, THREE DOLLARS.

PHILADELPHIA:

E. A. POSSELT, Author and Publisher,

2028 Berks St., and 2152 N. 21st St.

LONDON:

SAMPSON LOW, MARSTON AND COMPANY, LTD.

15a, Paternoster Row, E. C.

(Copyrighted by E. A. POSSELT)

PREFACE

The subjects covered by this volume are COMBING, DRAWING and FLY FRAMES, with a sub-chapter on ROLLER COVERING; taking up Cotton Manufacturing where Part 1* of this series of books left off.

The greatest of care has been exercised in the preparation of the present volume so as to bring every subject as plain as possible before the reader; special features of the new book being the numerous illustrations accompanying the text, as well as the hundreds of calculations systematically arranged.

The next volume (Part 3) in turn will take up Mule and Ring Frame Spinning; Winding, Doubling and Yarn Preparing Machinery and Processes.

*Subjects treated in Part 1 as published before are

HISTORY OF COTTON MANUFACTURING.

THE COTTON FIBRE: Botany, Structure, Properties, Composition and Cultivation; Sea Island Mainland and Foreign Cottons; Defects, Impurities, By-Products and Grading of Cotton

CLEANING, GINNING AND BALING.

PREPARATORY PROCESSES: Bale Breakers, Mixing, Picking, Cleaning Trunks; Breaker, Intermediate and Finisher-Scutchers; Notes, Mill Plans and Calculations for the various Processes and Machinery.

CARDING: Revolving Flat Card, Railway Head, Double Carding, Card Clothing, Grinding Burnishing, Stripping, Calculations.

Cassella Color Company

(AMERICAN BRANCH OF LEOPOLD CASSELLA & CO.)

Makers of the following

Cotton Colors

COTTON BLACKS

Diamine Blacks
Oxy Diamine Blacks
Diaminogenes
Oxy Diaminogenes
Diamine Jet Blacks
Diamineral Blacks

IMMEDIAL BLACKS

Immedial Brilliant Black
Immedial Carbone
Thiocarbone

DIAMINE COLORS

In all possible shades

IMMEDIAL COLORS

Immedial Blues
Immedial New Blues
Immedial Direct Blues
Immedial Indones
and a most complete line of fancy shades

BASIC COLORS

A complete line of basic colors for the dyeing of cotton
Naphthindone
Tannin Heliotrope
Irisamine
Thioflavine T
New Methylene Blue

Main Office and Warehouse in the United States

182-184 FRONT ST., NEW YORK.

Branch Offices: Boston, Philadelphia, Providence, Atlanta, Montreal.

TABLE OF CONTENTS.

COMBING.

	PAGE.
Description of the Process.....	1
SLIVER LAP MACHINE.....	3
Full Lap Stop Motion.....	6
Sliver Stop Motion.....	8
Calculations.....	8
Draft.....	8
Production.....	9
To Find the Number of Spools Filled per Day per Head.....	10
RIBBON LAP MACHINE.....	11
Rule for Setting Drawing Rolls.....	14
Calculations.....	14
Draft.....	14
Production.....	16
To find the Number of Spools Filled per Day per Head.....	16
COMBING.....	17
Description of the Course of Cotton Through the Machine.....	19
General Description of the Working Parts of the Machine.....	19
Feeding.....	21
Nipping.....	24
Combing.....	27
Detaching and Attaching.....	29
Method of Actuating the Top Comb.....	35
A Synopsis of the Operations During Combing.....	36
Delivering.....	38
Cleaning of the Cylinder Comb.....	41
Duplex Combers.....	42
Notes on Combing.....	43
Size of Flutes.....	44
Curling of the Fibres.....	45
Regulation of Waste Made.....	45
Settings and Timings.....	48
Driving of the Comber.....	52
Calculations.....	53
Draft.....	53
Production.....	55

	PAGE.
The Alsatian Comber	56
Extraction of Noils and Impurities from the Lap	60
The Mason-Monforts' Comber	75
The Nasmith Comber	80
The Nipper Frame and Plates	80
The Feed Roller	81
The Top Comb	82
The Detaching Mechanism	83
The Operation of the Machine	83

DRAWING.

Description of the Process	85
Stop Motions	93
Back Stop Motion	94
The Front Stop Motion	94
The Full Can Stop Motion	95
Electric Stop Motions	98
Drawing Rolls	99
The Bottom Rolls	100
The Top Rolls	101
Leather Covered Top Rolls	102
Varnishing and the Care of Rolls	106
Combination of Rigid and Yielding Surface Rolls	109
Metallic Drawing Rolls	110
Setting Drawing Rolls	113
Weighting of Top Rolls	117
Clearers	123
Calculations	126
The Mason Drawing Frame	130
The Saco and Pettee Drawing Frame	135
The Howard and Bullough Drawing Frame	140
The Whitin Drawing Frame	144
The Dobson & Barlow Drawing Frame	149

ROLLER COVERING.

Description of the Process	152
Roller Cloth	152
Roller Leather	153
Covering Rollers with Cloth	156
Cutting the Leather	157
Equalizing Skins by Grinding	158
Splicing or Bevelling of the Leather	159

	PAGE.
Piecing the Leathers.....	160
Drawing-on the Cots.....	161
Ending the Rollers.....	162
Finishing the Rollers.....	163
Truing and Varnishing Rollers.....	163
Testing Rollers.....	164
Hand Roller Covering.....	165

FLY FRAMES.

Description of the Process.....	167
The Slubber.....	168
The Intermediate Frame.....	168
The Roving Frame.....	169
The Jack or Fine Frame.....	169
Object of Fly Frames.....	169
The Creel.....	173
Points on the Construction and Operation of Fly Frames.....	176
Standard Sizes of Fly Frames.....	178
Drafting Rolls.....	178
Cap-bars.....	181
Setting the Rolls.....	182
Weighting the Rolls.....	183
Self-weighted Top Rolls.....	185
Draft.....	186
Roll Traverse Motions.....	187
Twisting the Roving.....	191
The Spindle.....	194
Flyers.....	195
The Bolster.....	199
Winding the Roving.....	199
Flyer-Lead.....	200
Bobbin-Lead.....	200
Cones.....	206
Differential Motion.....	210
Holdsworth's Differential.....	217
Daly's Differential.....	223
Howard & Bullough's Differential.....	228
Gearing Calculations of Howard & Bullough's Fly Frame.....	231
Curtis & Rhodes' Differential.....	236
Gearing Calculations of Platt Brothers & Co's Fly Frame.....	238
Dobson & Barlow's Differential.....	242
Builder Motion.....	244
The Horse Head.....	251
Tension Gear.....	254

	PAGE.
Tension Regulating Device	255
Lifting and Reversing Motion	256
Stop Motions	258
Hank Clock	261
Doffing	262
Notes	263
Worn Rolls	263
Bad and Uneven Roving	264
Long and Bad Piecings are a Distinct Evil	265
Mending Broken Ends	265
Empty and Full Bobbins	265
Speeds of Spindles	267
Revolutions of Spindle and Pulley per Minute	268
Spindles per Roll	268
Weight of Cotton on Bobbin, Expressed in Ounces	269
Management of Bobbins on Creel	270
Clean Machines Regularly	270
Gears	270
Oiling	271
Calculations	273
The Grading of Slubbing and Roving	273
A Constant Number	277
Draft	278
Twist in Roving	281
Cone Gear	283
The Lay Gear	284
The Tension Gear	285
Production	287
Calculating Production from Speed of Machine	287
To Calculate by Timing One Set Produced	289
To Calculate Production by the Hank Clock	289
Calculating Production from a Constant Number	290
A Short Method for Calculating Production	291
Changing the Twist	291
Regulating Production	292
Average Hank	292



INDEX OF ILLUSTRATIONS.

COMBING.

	PAGE.
Fig. 105. Perspective View of Sliver Lap Machine.....	4
106. Elevation of Course of Cotton through Sliver Lap Machine...	5
107. Plan View of Course of Cotton through Sliver Lap Machine..	5
108. Side Elevation of Full Lap and Sliver Stop Motion	7
109. Front Elevation of Full Lap and Sliver Stop Motion	7
110. Plan of Gearing of Sliver Lap Machine	9
111. Side Elevation of Gearing of Sliver Lap Machine.....	9
112. Perspective View of Ribbon Lap Machine.....	11
113. Elevation of Course of Cotton through Ribbon Lap Machine.	12
114. Plan of Gearing of Ribbon Lap Machine.....	15
115. Perspective View of Front of Comber.....	18
116. Perspective View of Back of Comber	18
117. Section of Comber.....	20
118. Mechanism for Driving Feed Rolls	22
119. Section of Feed Roll Stop Motion	23
120. Longitudinal View of Feed Roll Stop Motion	23
121. } Three Different Types of Nippers	25
122. }	
123. }	
124. Actuating Mechanism for Nippers.....	26
125. Notch Wheel Arrangement for Roller Motion	30
126. Quadrant Motion for Roller Motion.....	32
127. Clutch Box for Quadrant Motion	33
128. Method of Actuating the Leather Detaching Roller.....	34
129. Mechanism for Actuating the Top Comb.....	35
130. Diagrams of Combing Cycle.....	37
131. Plan View of the Delivery of a Comber.....	39
132. Plan View of a Double Delivery Comber.....	41
133. Section of a Duplex Comber	42
134. Plan of Gearing of Comber.....	53
135. { Diagrams Showing the Two Extreme Positions of the }	58
136. { Alsatian Comber during Combing	59
137. Diagram of Feeding and Attaching.....	62
138. Section of Combing and Attaching Arrangements.....	65
139. Mechanism for Oscillating Carriage.....	66

	PAGE
Fig. 140. Mechanism for Actuating Top Comb and Feed Card Roller...	72
141. Cross Section of the Mason-Monforts' Comber.....	76
142. } Diagrams Showing the Various Stages of the Combing	
to } Operations of the Mason-Monforts' Comber.....	79
146. }	
147. Section of Combing Portion of the Nasmith Comber.....	81

DRAWING.

148. Perspective View of Drawing Frame.....	85
149. Section of Drawing Frame.....	89
150. Plan View of Drawing Frames placed Straight.....	91
151. Plan View of Drawing Frames placed Crossed.....	91
152. Section of Full Can and Bung-Up Stop Motions.....	96
153. Section of Another Drawing Frame.....	97
154. Section of Solid Top Roll.....	103
155. Section of Shell Top Roll.....	103
156. Loose End Top Roll.....	105
157. }	
158. } Sections of Rigid and Yielding Surface Rolls.....	109
159. }	
160. Sectional Diagram of Metallic Rolls.....	112
161. Perspective View of Metallic Rolls.....	112
162. Diagram of Setting Drawing Rolls for 1¼" Staple.....	117
163. Diagram of Setting Drawing Rolls for 1½" Staple.....	117
164. }	
165. } Weighting Arrangement for Drawing Rolls.....	119
166. Weight Relieving Motion for Drawing Rolls.....	122
167. Diagram of Rotary Clearer for Top Drawing Rolls.....	125
168. Diagram of the Principle of Drafting.....	127
169. Plan of Gearing for Mason Drawing Frame.....	131
170. Plan of Gearing for Saco & Pettee Drawing Frame.....	136
171. Plan of Gearing for Howard & Bullough Drawing Frame.....	141
172. Plan of Gearing for Whitin Drawing Frame.....	145
173. Plan of Gearing for Dobson & Barlow Drawing Frame.....	149

ROLLER COVERING.

174. Diagram of Skin for Roller Covering.....	155
175. Cloth Cutting and Pasting Machine.....	156
176. Leather Cutting Board.....	158
177. Leather Bevelling Machine.....	159
178. Diagram of Two Kinds of Bevels for Cots.....	160
179. Pulling-on Machine.....	161
180. Roller Tester.....	164

FLY FRAMES.

	PAGE.
Fig. 181. Perspective View of Front of a Roving Frame.....	171
182. Perspective View of Back of a Roving Frame.....	172
183. Elevation of Fly Frame Showing Course of Roving.....	174
184. Elevation of a Different Shape Creel.....	175
185. Plan of Placing Spindles.....	177
186. Elevation of Roller Stand.....	179
187. The Woonsocket Ball Bearing Top Roll.....	180
188. Diagrams Showing Arrangement for Cap Bars.....	181
189. Elevation of Traverse Motion.....	189
190. Facsimile of the Traverse of the Roving.....	189
191. Elevation and Section of Flyer, Spindle, Bobbin, etc.....	192
192. Specimen of Flyer Leg with Straight Slot.....	195
193. Specimen of Flyer Leg with Curved Slot.....	195
194. Perspective View of the Dunn Flyer.....	198
195. Perspective View and Detail of Another Style of Flyer.....	198
196. Diagram Showing Bobbin Lead.....	201
197. Diagram Showing Flyer Lead.....	201
198. Diagram Showing Reduction in Speed for Bobbin.....	205
199. Diagram Showing the Lay Out for a Pair of Cones.....	209
200. Plan of Gearing of Fly Frame.....	211
201. Diagram of an Epicyclic Train of Wheels.....	212
202. Differential Motion for Hand Yarn Reels.....	214
203. Holdsworth's Differential Motion.....	217
204. Daly's Differential Motion, Perspective View.....	223
205. Daly's Differential Motion, Showing Internal Gears.....	224
206. Plan of Gearing for Daly's Differential.....	226
207. Howard & Bullough's Differential Motion.....	229
208. Front Elevation of Gearing, etc., of H. & B., Frame.....	231
209. } Side Elevations of Gearing, etc., of H. & B. Frame.....	231
210. }	
211. Perspective View of Headstock of H. & B. Frame.....	232
212. Curtis & Rhoades' Differential Motion.....	236
213. Diagram of Gearing of Platt Brothers & Co's Fly Frame.....	240
214. Dobson & Barlow's Differential Motion.....	243
215. Diagram of the Hill Builder.....	249
216. Diagram of Horsehead Showing Two Carriers Used.....	252
217. Arrangements of Twin Vertical Shafts.....	254
218. Tension Regulating Device.....	256
219. Lifting and Reversing Motion.....	257
220. Stop Motion for Full Bobbins.....	259
221. Detail of Stop Motion.....	259
222. Safety Stop Motion.....	260
223. Erskine's Cone Stop Motion.....	261
224. Doffing Motion.....	262
225. Self Oiling Spindle Step for Woonsocket Frames.....	272

A. KLIPSTEIN & Co.

122 Pearl Street

NEW YORK.

BRANCHES:

Boston, Providence, Philadelphia, Chicago, Montreal and Toronto, Canada.
FRANKFURT a/M, GERMANY.

- Anilines.** **SULPHUR DYES:** Thiophenol Blacks, Pyrogen Blues, Pyrogen Greens, Browns, Yellows.
DIRECT COTTON DYES: Carbide Blacks, Direct Indigo Blue BN, Direct Greens, Pinks, Browns, Yellows.
BASIC DYES: Fast Blues, Auramines, Rhodamines, Greens, Violets.
- Dyestuffs.** Hematine, Fustic Extract,
Sumac Extract, Cutch,
Aniline Salt and Oil.
- Chemicals.** Bluestone, Antimony Salts,
Formic Acid
Chlorates Potash and Soda
Acetate Alumina
Acetate Chrome
Formate Alumina
Formate of Chrome
Glauber's Salt, etc.

SIZING MATERIALS.

Cohnen Centrifugal Dyeing Machine.

COMBING.

The sliver or ribbon as coming from the carding engine is composed of fibres ranged in fairly parallel order. The next preparatory process to which the sliver is subjected, depends upon the character of the fibre or yarn under operation. For the average kind of yarns, drawing is the process following, whereas for the better class of yarns (about 60's and above) the process of combing previous to drawing is introduced, although in some instances one process of drawing may precede combing. Yarn which only passes through the drawing frame is called carded yarn, while that which goes through the comber is called combed yarn. Even yarn depends chiefly upon three factors which are practically unattainable by the use of the card alone:

First, the fibres composing the yarn must be uniform in length. We must acknowledge that this result is impossible to be obtained with the most perfect card of the present day, although the revolving flat card of to-day approaches nearer perfection than its predecessors. Examining closely a carded sliver will at once convince us that large quantities of irregularly stapled cotton exist therein and which in turn must be eliminated from the sliver before the higher counts of yarn can be spun.

Second, the fibres must be arranged individually and in parallel order and which position must be maintained. The cotton fibre, on account of its natural twist, has a normal tendency to curl up, and consequently readily becomes crossed and tangled during its treatment by the various machines. This is very readily seen if a carded web is closely examined. The fibres, although presented to the action of the card wire in a straight manner, very speedily, as soon as they are freed, assume a crossed and tangled form, due to their natural elasticity, for which reason a considerable amount of drawing is found necessary before they are again restored to a more or less parallel order.

Third, the fibres must be incorporated together in an even manner. By this we mean that the individual fibres composing the sliver must regularly overlap each other in such a way as to give strength to the sliver and in turn afterwards to the roving and yarn. It will be readily understood that with reference to carding, the binding of the fibres into a strand of sliver depends on no fixed method in their distribution or arrangement, a feature which certainly shows a weak spot in the latter process.

These three conditions, so necessary to the production of even yarns, are readily obtained by the use of the combing machine. The operation of combing in itself may be defined as the most perfect application of the principle of carding and as its name implies is a

combing operation, that is, every fibre of cotton is practically isolated and combed out, and maintained in this condition by the pressure of the surrounding fibres. The process also eliminates from the material all the fibres that are below the standard length to be used in the yarn, and at the same time substantially rids the cotton of impurities which may have escaped the carding process. In this manner, combing has rendered possible the use of cottons formerly regarded as quite unsuited for the spinning of fine yarns, thus increasing the amount of available material, and widening the area of selection, which condition has materially reduced the prices of fine yarns to a lower figure, thereby extending their application and increasing their consumption.

It is a well known fact that comber waste (noils) is worth more than card waste, for which reason some mills will take out less waste on the card, in order to increase the waste on the comber. The disadvantages to this method are that so much extra work being put on the combs is naturally very injurious to them, besides not allowing as thorough combing of the fibres passing through the comb. Furthermore, each machine (card and comb) is built to do so much work in the preparatory process, and should be run to this. If, as mentioned before, the card is favored, an extra amount of work is thrown on the comber, with the result that quality will suffer. The percentage of short fibres taken out by the comb depends upon the grade of cotton that is used and the fineness of the yarn it is required to spin. Roughly speaking, the amount may vary from 10 to 30 per cent.

When using long stapled cottons heavily charged with impurities it has been found necessary to submit the cotton to a double process of combing, there being several methods in vogue for this process, all subject to varying conditions in fibre, machinery, as well as climate. When a ribbon lap machine is used in connection with it, the most common combination of machines is thus:

- | | |
|------------------------|------------------------|
| 1. Sliver lap machine, | 4. Sliver lap machine, |
| 2. Ribbon lap machine, | 5. Ribbon lap machine, |
| 3. Comber, | 6. Comber. |

In some instances the ribbon lap machine above referred to is omitted in both processes, a draw frame, preceding the sliver lap machine, being introduced in both processes.

Although not advisable, except for production, drawing either by ribbon lap or draw frame in either process, is in some instances omitted.

It would seem at first thought that double (and treble when used) combing would produce a much superior yarn than single combing, a feature which however is not the case, although double combing certainly improves the character of the yarn. The advantage of double combing is best explained by an example: Suppose we take out 24 per cent noils with single combing and a total of 24 per cent with double combing; should not the yarn be as clean from the single combing as from the

double? We should say very likely "no," since in double combing we may have taken out only 17 per cent at the first combing and the remaining 7 per cent at the second combing. Having double the quantity of needles or combs acting on the cotton, for the same percentage of noils, will necessarily give a more thorough cleaning and combing action to the fibres. The reason for the difference in percentages of the two combings, although the settings for the two combs being practically the same, is found in the fact that in the second combing there is not much short fibre to be dealt with in the cotton under operation. The same affair, in proportion, refers also to treble combing where such is ever used, the difference between 2nd and 3rd combing being less pronounced than between 1st and 2nd. Treble combing, as readily understood, will result in a high priced yarn, both on account of labor as well as the high price of the raw cotton which has to be used, for which reason it is seldom employed. Besides the advantages attributed to double combing, the same also has its disadvantages, found in the fact that a good deal of trouble is introduced, as the slivers lose some of their strength because the fibres have become so parallel and feel so soft that they stick to almost anything, and when any slight shock or strain is sufficient to break them.

Cans with spring bottoms are frequently used at the coiler, in order to assist the slivers to more readily mount to the top. All plates or guides that the cotton has to impinge against during combing must be kept clean and dry. Combed cotton is much more susceptible to disturbance by electrical influences, or air currents, than carded cotton. A micro-photographic view of combed staples drawn out from a combed sliver will show a true cohesion of the fibres before any twist worth speaking about has been imparted to them, thus possibly explaining the problem how cotton fibres retain their hold on one another when drawn out of the sliver cans; the calendaring which combed as well as uncombed fibres receive, serving as nothing if it were not for the spirality of the individual cotton fibres, a feature readily proven by the fact that half ripe cotton fibres are more difficult to draw than fully ripe fibres.

SLIVER LAP MACHINE.—Before the sliver from the card is taken to the comber, it must undergo a preparatory process, because combing is necessarily a delicate operation. An examination of the arrangement of the fibres in the carded sliver shows it to be of such a nature that the needles of the comber would be liable to considerable damage if an attempt were made to comb them in this state; and, secondly, owing to the great irregularity of the card sliver it would be reproduced in the comber, and at the same time cause very unequal work to be thrown on the various parts of that machine, with the result that a great many good fibres would be taken out as waste. In preparing the cotton for the comber, another consideration must be taken into account. When the cotton is passed through the comber, it comes in contact with a series of very fine steel needles, each row having a width of from 7 to 11

inches. This introduces the necessity of making a lap from the slivers for a corresponding width of needles, for which reason the slivers as taken from the card are passed side by side through a machine called a sliver lap machine, of which a perspective view is given in Fig. 105. This machine as built by the Whitin Machine Works, doubles 12 to 19 slivers and condenses them into the form of a lap, ready to be placed on the ribbon lap machine or the comber as the case may be. If the ribbon lap machine is to be used, the lap on the sliver lap machine is

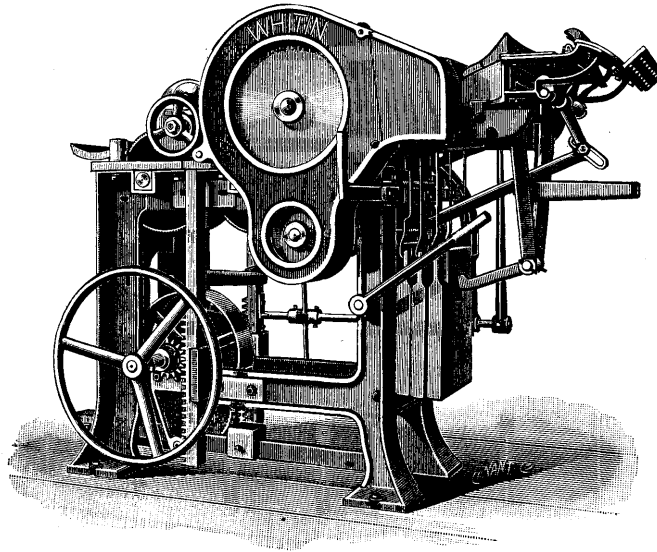

FIG. 105.

made $1\frac{1}{4}$ inches narrower than the lap to be made on the ribbon lap machine, in order to allow for spreading in said machine. The lap is very compactly made on a wooden spool, 4 inches in diameter, and when full is from 9 to 12 inches in diameter.

The course of the cotton through the machine is shown in Figs. 106 and 107, of which Fig. 106 is a side elevation, with rollers shown in section, and Fig. 107 a plan view of a sliver lap machine.

Starting at the back of the machine, the slivers *A* are passed from the cans *B*, separately through small round apertures *C* in the guide plate *D*, which by placing in certain positions will put more or less tension on the slivers *A*. Passing through the guide plate *D*, each sliver *A* goes under a small round bar *E* held by the arms *F* and from there over a spoon lever at *G*, which is a part of the automatic stop motion on the machine, causing the latter to stop when a sliver *A* breaks or a can *B* runs empty. The small round bar *E*, between *D* and *F*

serves the purpose to keep the slivers better down on the spoons *G*, thus obtaining a prompt action of the stop motion. From the spoons *G*, the slivers pass down a specially shaped guide plate *H*, each sliver being kept separated from the others by means of grooves or channels *I*, through which they pass. The slivers are in this manner brought

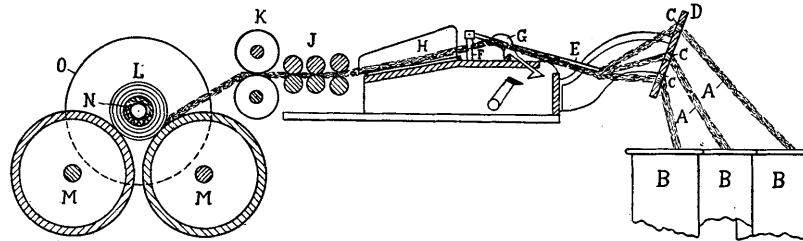

FIG. 106.

together and made into a comparatively level sheet without overlapping each other as they enter the series of drawing rolls *J*, side by side. The object of the machine is not to draw the slivers out, but to lay them side by side in the form of an even lap, for which reason the draft in the rollers *J* is just enough to prevent bulkiness of the lap and should not exceed about $1\frac{3}{4}$ to 2. Emerging from the drawing rolls *J*, the cotton

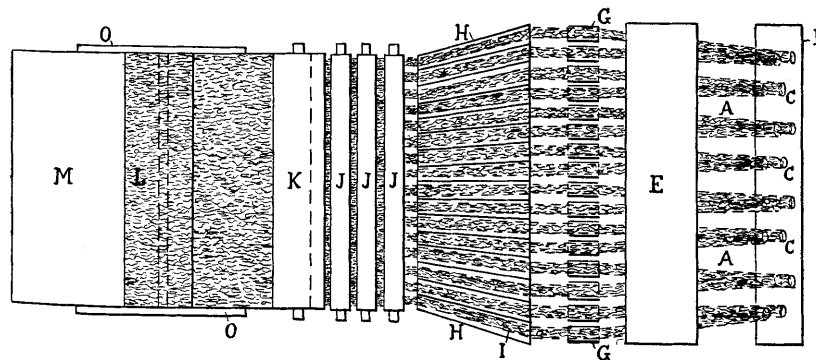

FIG. 107.

is conducted between a pair of heavy calender rolls *K*, which compress it into a sheet or lap which enables it to be rolled up. The top calender roller *K* is weighted either by a spring or lever arrangement at each end, with from 80 to 140 lbs. pressure. After the cotton leaves the calender rollers *K*, it is wound in the form of a lap *L*, upon the wooden spool *N*

which is revolved by bringing it in frictional contact with the two large fluted iron rollers *M*. This wooden spool *N*, on which the lap is wound, has its centre bored out to allow a spindle to pass through it. This spindle has one end threaded and a hand wheel on the other. The threaded end screws into a large plate, the inside surface of which is smooth. The other end of the spindle carries a plate similar to the other one, except for the fact that it carries on its outside hub a saw-toothed edge, which fits into another similar hub which is carried on the spindle. When the lap is to be started, the spindle is run through the two plates and spool, which is placed between them, and then the hand wheel is turned in a direction so as to tighten the spool up tight against the face of the plates, and then the racks that hold the plates up are lowered until the spool rests firmly upon the fluted rolls. The cotton is then passed around the spool and the machine started. The edges of the lap, during winding, are kept smooth and even by large, circular, smooth, iron plates *O*, placed tightly up to the ends of the wooden spool, and in turn revolving with the spool by means of friction, thus preventing the lap ends from bulging out, also avoiding any friction of the lap ends with the framing of the machine. The lap is made compact in a similar manner as the lap made on a scutcher in the preparatory department; that is, the upward movement of the spindle as extending through the spool, due to the increasing diameter of the bobbin, is retarded by a brake arrangement. This brake acts upon the lap by having the spindle project at both ends through the side plates and held by the projections on the vertical racks, these racks being geared into spurs which are on the same shaft with the brake pulley. This retarding action necessarily causes the lap to wind on the bobbin in a compact manner.

The sliver lap machine is generally fitted with a full lap stop motion, in order to make the bobbins of uniform size. As there are 12 to 19 slivers fed to the machine at one time, another stop motion to take care of these slivers is absolutely necessary to produce an even lap. These two stop motions are shown in connection with Figs. 108 and 109, from which it will be seen that most of the parts are common to both motions.

Full Lap Stop Motion.—As explained before, the spindle through the bobbin is held by curved projections on the top ends of the racks, which are in gear with spur gears on the same shaft with the brake pulley. Referring to the illustrations, *A* indicates the lap, and *B* is one of the vertical racks, on which is placed a vertically movable piece *C*, which can be set for any size lap. As the lap is wound on, the bobbin increases in diameter and causes the rack *B* to rise, taking the piece *C* with it. When the bobbin is full, said piece *C* has risen so that it comes against the end of a horizontal rod *D*, and by overcoming the resistance of the spring *E*, causes the other end of the rod *D* to press against the bottom arm of the bell crank lever *F*, centered at *G*, which gives an

upward movement to the other arm of the lever. Directly above this arm is a catch arm *H*, which catches against the framing of the machine

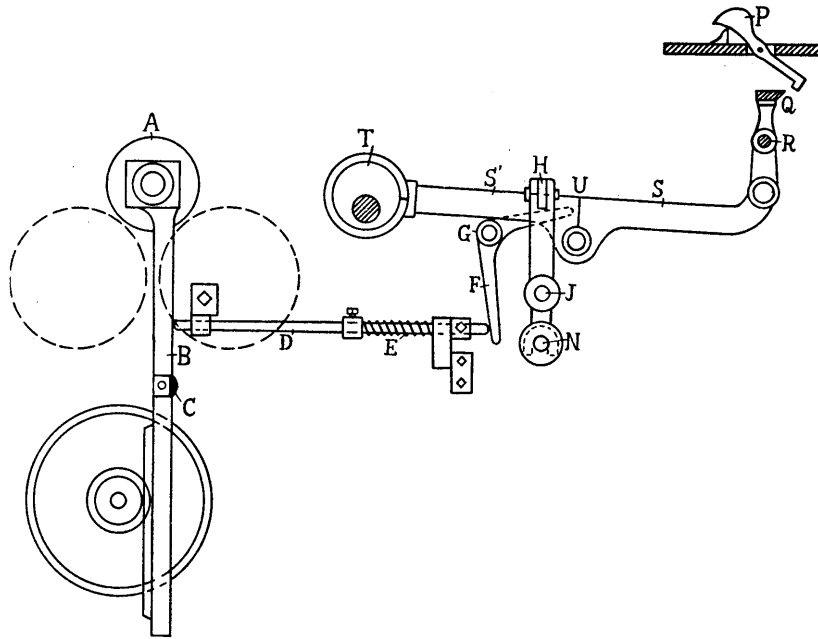

FIG. 108.

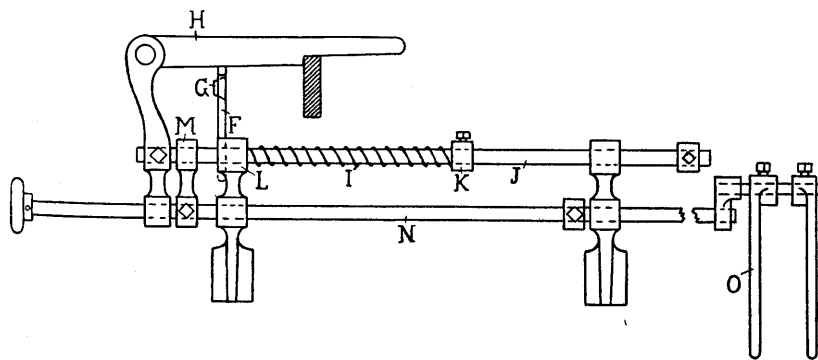

FIG. 109.

and prevents the spring *I* on the rod *J* from moving it in a horizontal direction. As the top arm of the bell crank lever rises, it pushes the catch arm *H* up out of contact with the framing and thus liberates the

spring *I*. This spring, having been compressed by the dog *K* on the rod *J* and the bearing *L*, when freed, will push the dog *K* forcibly outward, carrying the rod *J* with it. On the left end of the rod *J* is fastened a short rod *M* which is also rigidly fixed to the shipper rod *N*, so that when the top rod *J* is moved in an outward direction, the shipper rod is simultaneously moved in the same direction, which causes the belt fork *O*, that is attached to the shipper rod, to shift the belt from the fast to the loose pulley. In starting the machine, the belt is shifted on to the fast pulley, when the catch arm *H* falls in contact with the framing of the machine, and thus keeps the belt on the fast pulley.

Sliver Stop Motion.—This motion is also known as the spoon stop motion, because spoon shaped levers are employed. These spoons are pivoted at the centre, having their lower ends slightly heavier than their upper ends. Each sliver passes over a separate spoon *P*, and by its weight holds the lower end of the spoon up. Directly under the lower ends of the spoons is an oscillating knife bar *Q*, extending the full width of the machine, being centered at *R* and having its lower end connected to the double fulcrum arm *SS'*. This arm is moved back and forth by means of its connection with the eccentric *T*, which is driven positively through suitable gearing (not shown). This movement of the arm *SS'* gives the oscillating motion to the knife *Q*, which can move freely when the lower end of the spoon is held up out of its path. All the parts of the stop motion are inoperative while the spoon is held up, except the oscillating movement of the knife bar *Q*. When a sliver breaks or leaves the spoon from any cause whatever, its lower end falls into the path of the oscillating knife bar *Q* and engages it, thus preventing its movement. The continued movement of the eccentric *T* causes the double fulcrum lever *SS'* to break at the joint *U*, and the front half of the arm *S'*, goes upward by this movement and presses against the catch arm *H*, thus liberating it in the same manner as in the case of the full lap stop motion, and stopping the machine as has been explained before. When the spoon is held up again, the double fulcrum lever *SS'* regains its original position and the machine continues to run until another spoon drops down.

The settings of the draw rolls in a sliver lap machine are closely related to those for the ribbon lap machine, and on account of the greater importance of the latter machine, will be dealt with under that head.

Calculations.—Fig. 110 is a top view and Fig. 111 a side elevation of the gearing of a sliver lap machine. The numbers of teeth in the gears are indicated in the illustrations, the diameters of the rolls being as follows: The steel draft rolls are $1\frac{1}{2}$ inches, the calender rolls 5 inches and the large fluted friction rolls 12 inches in diameter.

To Find the Total Draft on the Sliver Lap Machine: The draft on this machine is the ratio of the surface speed between the back draft

roll and the friction roll at the front of the machine and in connection with the machine shown is thus:

$$\frac{12 \times 12 \times 72 \times 20 \times 26 \times 24 \times 64}{1\frac{1}{2} \times 72 \times 29 \times 20 \times 50 \times 41 \times *} = 64.48 \text{ draft constant.}$$

Draft Constant ÷ Gear = Draft.

Draft Constant ÷ Draft = Gear.

Example: Say we want to make a draft of 2 on the machine; what change gear will we have to use?

$$64.48 \div 2 = 32.24 = 32 \text{ gear.}$$

To get the actual draft with the 32 gear used:

$$64.48 \div 32 = 2.015 \text{ actual draft.}$$

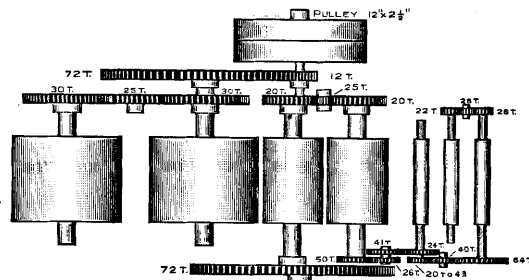

FIG. 110.

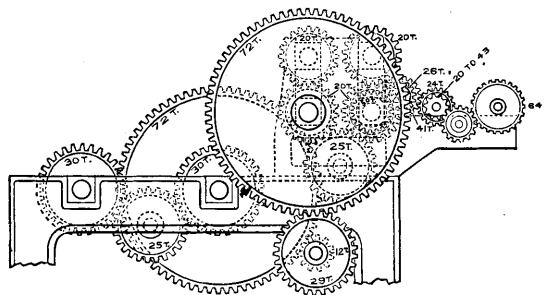

FIG. 111.

Production.—The production of a sliver machine is best figured from the surface speed of the calender roll, the weight per yard of the

lap and the time run. The usual speed to drive the pulley on a sliver lap machine is between 120 and 240 revolutions per minute.

Example: Find the production of a machine for a day of 10 hours, allowing 10% loss for stoppages, etc., the driving pulley to make 120 revolutions per minute and the weight per yard of the sliver being 250 grains.

The surface speed of the calender roll is obtained by figuring from the speed of the driving pulley

$$\frac{120 \times 29 \times 5'' \times 3.1416}{72 \times 36''} = 21.09 \text{ yards per minute.}$$

Then yards per minute \times time run \times weight per yard \div 7000 (grains per pound) = pounds production per day.

$$\frac{21.09 \times 540 \times 250}{7000} = 406.85 \text{ pounds per day.}$$

To Find the Number of Spools Filled per Day per Head: Subtract the weight of the wooden spool from the weight of the full spool and divide that weight by the weight per yard of the lap. This gives the yards of lap on the spool. From the surface speed of the calender roll, and the time run, figure the total number of yards of lap produced. Then by dividing the number of yards produced by the number of yards on a spool, we get the total number of spools filled per day per head.

Example: Find the number of spools filled for a day of 10 hours, allowing 10% loss for stoppages, etc., the driving pulley to make 150 revolutions per minute, the lap to weigh 240 grains per yard, the full spool to weigh 8 lbs., the empty spool weighing 2 lbs.

8 lbs. — 2 lbs. = 6 lbs. weight of lap on spool.

$$\frac{6 \times 7000}{240} = 175 \text{ yards on a full spool, and}$$

$$\frac{150 \times 29 \times 5'' \times 3.1416}{72 \times 36''} = 26.36 \text{ yards delivered per minute, and}$$

26.36 \times 540 = 14234.4 yards delivered per day, and

14234.4 yards \div 175 yards = 81.3 = 81 spools filled per day.

The amount of cotton that can be put on a spool depends upon the amount of friction on the spool and on the size desired.

The number of spools filled per day depends upon the speed of the machine, the weight per yard of the lap produced, the working time and the amount of friction on the spool.

RIBBON LAP MACHINE.—The cotton as coming from the sliver lap machine has simply been converted into a lap, so that it is in the desired shape for being worked on the ribbon lap machine, the object of which is to make a more uniform lap, ready for the combing process. This machine, like the drawframe, as will be explained later on, draws the fibres composing the lap more parallel, and makes the lap more uniform, in the same way that the drawframe makes slivers more uniform. By this process of drawing the laps out, another advantage is secured in that it takes out the individuality of the slivers which compose the lap made on the sliver lap machine, and amalgamates the fibres so as to make a ribbon or narrow lap which is more uniform in thickness all across its width than is possible to be got from the sliver lap machine alone. A third advantage aimed at by the use of a ribbon lap machine is that by means of this process the nippers of the combers are able to get a more perfect grip on the fibres, a feature most beneficial to the satisfactory combing of the cotton.

A perspective view of the ribbon lap machine as built by the Whitin Machine Works is given in Fig. 112, and which shows its general arrangement. Fig. 113 is a section through the operating parts of the machine, showing the course of the cotton.

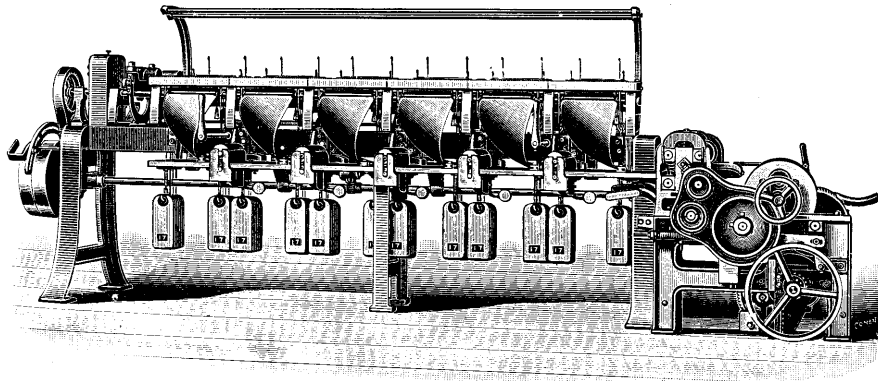

FIG. 112.

The cotton is fed to the machine in lap form and is taken from it in the same form, the only difference in the two being that the final lap is about an inch wider. This machine is as a rule composed of six heads

(although 8 may be used), each head being complete in itself, except the drive which is common to all; the production of all the heads being finally combined into one lap.

Six laps, one for each head, $7\frac{1}{2}$ inches wide, made on the sliver lap machine, are placed on wooden fluted lap rollers *A*, at the back of the ribbon lap machine, said rollers by means of frictional contact with the laps *B*, unwinding the same slowly. The lap is then taken forward by passing through the four pairs of drawing rollers *C C' C''* and *C'''*. Between the wooden rollers *A* and these drawing rollers, the lap in its course through the machine passes over a balanced plate lever *D* which serves the same purpose in the back stop motion of this machine, as the spoon levers in the stop motion of the sliver lap machine previously explained. From the balanced plate lever *D*, the lap is passed through guides *E*, which prevent it from spreading out, as is its natural tendency to do all through the machine. The total draft between the drawing rolls *C C' C''* and *C'''* is about six. The cotton emerges from the rolls

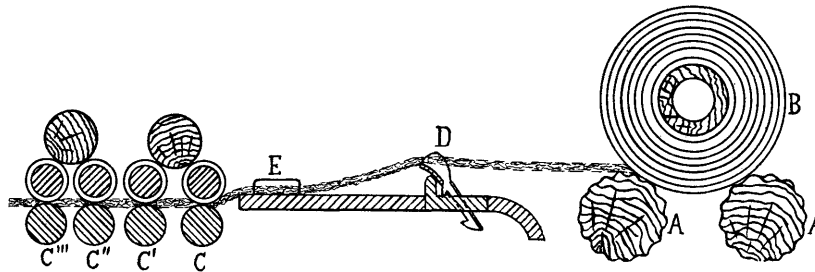

FIG. 113.

in the form of a fine sheet and from there passes over a curved web conductor, six of them, one for each head, being clearly shown in the perspective view of the machine given. The object of these curved conductors is to conduct the film of cotton, in its full width, from the delivery of the drawing rolls to the front table, which necessitates deflecting the cotton film 45° . The curve of the conductor is of such a shape that the tension over the entire width of the film is the same. As stated, the film passing over the curved conductor, goes on to the front table, which is simply a highly nicked piece of iron, about 12 inches wide, extending the entire width of the machine so that the thin sheets or films can readily pass along on it in their full width. As each sheet comes from its curved conductor on to the table, it passes through a pair of carrying rolls, and as the sheets pass along the table toward the winding mechanism, they become superposed on each other (each head delivering its film on the preceding one) and in this position pass forward, together, through the next pair of carrying rolls. The last pair of carrying rolls is near to and delivers to the winding motion, which in turn winds the combined sheets upon a spool, in the same manner as on

the sliver lap machine. In order to secure laps of uniform length, a full lap stop motion is also provided on this machine, the mechanism being the same as that explained in connection with the sliver lap machine.

The superposing of the six webs one upon the other gives a very uniform section through the width of the lap, a feature which enables the comber nippers to hold the fibres more firmly, the result being a substantial reduction in the amount of waste made on the comber. This procedure of doubling the laps on the ribbon lap machine is similar to that employed at the feed end of a finisher scutcher, the chief difference being that the scutcher has a traveling lattice for passing the laps forward, while the ribbon lap machine has carrying rolls instead. Metallic rollers are strongly recommended for use in these machines, but if leather top rollers are used, they should have loose ends. The curved web conductors are in some instances of polished cast iron, but the tendency is to cover them with sheet brass, which is capable of taking a higher polish and thus enables the sheets to pass over them more easily. A disadvantage to the proper working of the machine is that on account of the films of cotton being so thin at the time they are passing over the curved conductors, said films are easily diverted from their proper course and in turn make irregular laps. Another disadvantage to the machine is the breaking of the ribbons, due to several causes, among the most common being, laps licking at the drawing rolls, too much draft between the drawing rolls, too great a speed of the drawing rolls or the calender rolls, and the drawing rolls cutting the films of cotton. The machine has no stop motion between the back stop motion and full lap stop motion, previously referred to, consequently when a ribbon breaks in the machine, the same continues to run, in turn breaking down other ribbons, owing to the obstruction which the first broken ribbon makes, until the operator stops the machine. The partially filled spool has then to be removed and any thin part of the lap taken off, another empty spool placed in the machine, the partially filled spool afterwards being worked in the comber. The broken ribbons are then pieced up, and when the complete lap has come through the last pair of calender rolls, the waste thus made is removed and the lap guided on to the empty spool and the machine run at full speed. Although it is usual to run the six heads on the machine, yet in some cases only five are used, as in this instance a heavier sliver lap can be used with the same draft as with six heads. The ribbons from each head, in this instance, will be heavier and less liable to break in their passage to the lap winding motion, besides the ribbon which had to travel the greatest distance on the front table is the one cut out of the machine, hence reduces the liability of breakages. However, as stated before, the object of this machine is to get the fibres in as parallel an order as possible for action upon by the needles of the comber, and which is better accomplished by the use of this machine than if a drawframe is used between the card and the sliver lap machine, and such laps in turn subjected to the comber.

Rule for Setting Drawing Rolls.—Set the centre of the front and centre of the second pairs of rolls one eighth of an inch farther apart from each other than the length of the staple of cotton under operation, increasing this initial distance $\frac{1}{8}$ inch for every succeeding pair of draw rolls. There are two combinations in the size of bottom rolls used, viz: First, having all the bottom rolls of a uniform diameter = $1\frac{1}{2}$ inches. A disadvantage found in connection with this arrangement is the fact that the first and second pair of rolls cannot be set close enough for short staple stock to produce satisfactory work. Second, using a smaller diameter, say $1\frac{1}{4}$ inches, for the second bottom roll, leaving the other rolls $1\frac{1}{2}$ inches diameter as before. This permits the setting of the second roll to be one fourth of an inch closer to the first roll than would have been the case provided the first mentioned arrangement of using bottom rolls of a uniform diameter ($1\frac{1}{2}$ inches) would have been used. This setting of the rolls in a ribbon lap machine is best explained by means of a practical example: Suppose that a Sea Island cotton having a $1\frac{1}{8}$ inch staple is under operation. In this case set distance from centre of first to centre of second bottom roll 2 inches; distance from centre of second to centre of third bottom roll $2\frac{1}{8}$ inches; distance from centre of third to centre of last bottom roll $2\frac{1}{4}$ inches. This increase of one eighth of an inch between the bite of each pair of rolls is allowed for extra bulk. While rule given comprises a fair average setting, changes from it will often be made to suit the whim of an overseer, for instance, one sixteenth of an inch excess over the length of staple, is sometimes used in place of one eighth of an inch as mentioned before. However as there is a constant tendency amongst cotton spinners, on account of production, to use as heavy a weight sliver as possible, it will be found that one eighth of an inch in excess of the length of the staple between the front and second rolls, and gain one eighth of an inch for each pair of rolls, as given in rule, will not be too great a distance to produce satisfactory results. In setting the bottom rolls by the rule given, with brass gauges, when the second roll is $1\frac{1}{4}$ inches in diameter, there is no need to alter the gauge at all when spacing the third and last rolls after setting the second and third rolls, because the distance between the sides of the two rolls will be alike, that is, three fourths of an inch. The top leather rolls are, when covered, slightly larger than the diameter of the bottom rolls, in order to help prevent channeling of the top rolls. If using metallic rolls, the same size of top roll is to be used as in the bottom roll.

Calculations.—The principal draft on a ribbon lap machine occurs between the drawing rolls, but as there is a slight draft necessary between the lap rolls and drawing rolls, also a slight draft between the drawing rolls and lap drum, so as to keep the sheet of cotton in either instance taut, it is necessary, in order to get the total draft, to get the ratio of surface speeds between the lap roll and the lap drum.

The draft of the machine, with reference to calculations given, is figured from the diagram of gearing shown in Fig. 114. It will be

noticed that there are slight changes in the gearing when using metallic rolls, so that draft constants for using both kinds of rolls will be given for the same machine.

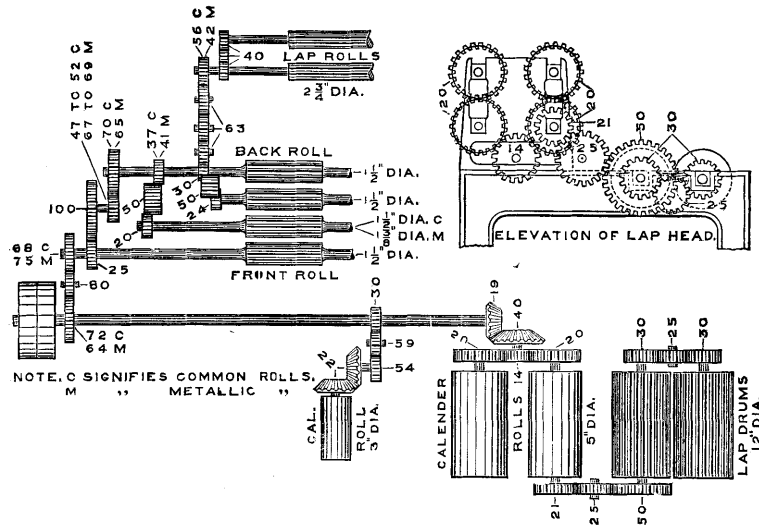

FIG. 114.

Draft constant for metallic rolls:

$$\frac{12 \times 21 \times 14 \times 19 \times 75 \times 100 \times 65 \times 42}{2\frac{3}{4} \times 50 \times 20 \times 40 \times 64 \times 25 \times * \times 30} = 262.32$$

Draft constant for leather top rolls:

$$\frac{12 \times 21 \times 14 \times 19 \times 68 \times 100 \times 70 \times 56}{2\frac{3}{4} \times 50 \times 20 \times 40 \times 72 \times 25 \times * \times 30} = 300.806$$

Draft constant ÷ Gear = Draft.

Draft constant ÷ Draft = Gear.

Example: Say we want to have a draft of 6.25 on the machine, using metallic rolls, what gear will we use?

$$262.32 \div 6.25 = 41.9 = 42 \text{ gear.}$$

Then the actual draft would be—

$$262.32 \div 42 = 6.245.$$

Example: What gear will we use to make the same draft using leather top rolls?

$$300.806 \div 6.25 = 48.09 = 48 \text{ gear.}$$

Then the actual draft would be—

$$300.806 \div 48 = 6.262.$$

Example: We use metallic rolls, and have a 45 draft gear on the machine, what is the draft produced?

$$262.32 \div 45 = 5.83 \text{ draft.}$$

Example: By using leather top rolls, and having a 52 draft gear on the machine, what draft is produced?

$$300.806 \div 52 = 5.78 \text{ draft.}$$

The production of the ribbon lap machine is figured in the same manner as the sliver lap machine.

Example: Find the production of a ribbon lap machine for a day of 10 hours, allowing 10% loss for stoppages, etc., the lap weighing 250 grains per yard and the driving pulley making 280 revolutions per minute.

The surface speed of the lap drum is—

$$\frac{280 \times 19 \times 14 \times 21 \times 12'' \times 3.1416}{40 \times 20 \times 50 \times 36''} = 40.947 \text{ yards per minute.}$$

$$\frac{\text{Yards per minute} \times \text{time run} \times \text{weight per yard}}{7000} = \text{lbs. production per day.}$$

$$\frac{40.947 \times 540 \times 250}{7000} = 789.7 \text{ pounds per day.}$$

To Find the Number of Spools per Day per Head, proceed in the same manner as in the sliver lap machine, using the correct weights, and surface speed of the lap drum for that machine.

Example: Find the number of spools filled for a day of 10 hours, allowing 10% loss for stoppages, etc., the driving pulley to make 275

revolutions per minute, the lap to weigh 240 grains per yard, the full spool to weigh $8\frac{1}{2}$ lbs., the empty spool weighing $2\frac{1}{2}$ lbs.

$$8\frac{1}{2} \text{ lbs.} - 2\frac{1}{2} \text{ lbs.} = 6 \text{ lbs.}$$

$$6 \times 7000 \div 240 = 175 \text{ yards on a full spool, and}$$

$$\frac{275 \times 19 \times 14 \times 21 \times 12'' \times 3.1416}{40 \times 20 \times 50 \times 36''} = 40.22 \text{ yards delivered per minute, and}$$

$$40.22 \times 540 = 21718.8 \text{ yards delivered per day, or}$$

$$21718.8 \text{ yards} \div 175 \text{ yards} = 124.2 = 124 \text{ spools filled per day.}$$

COMBING.—The essential conditions of the lap necessary to economical combing having been obtained in the ribbon lap machine, it is now taken to the comber, a machine which in its delicate construction and action upon the cotton far surpasses carding. However, although the combing process is very efficient with reference to removing the short fibres and impurities the cotton still contains, the same can only be used in connection with carded cotton, thus being more or less a substitute for the second carding process as formerly extensively used and, for special yarns in mills having no combers, to some extent still in vogue. One particular point in connection with combing is that the material must be acted upon lengthwise by the combs, since on the circumference of the comb cylinder there are about 17 combs arranged in rows, each row back of the other being finer than the one preceding it; there being in some machines 30, or more, teeth per inch in the front row, and up to about 100 in the last row. The reason for this disposition of the needles in the combs is that the cotton will be treated progressively, the coarser needles preparing it for the finer ones which follow, in turn ensuring a minimum of damage to the fibres in connection with a maximum amount of cleaning. Only small portions of the lap are treated to the combing action successively at a time. The fibres are first held at their rear ends, while their forward ends are combed out by the steel combs on the cylinder. As soon as the front ends are combed the fibres pass forward through the machine, and in doing so, have their rear ends combed out by means of a comb situated at the top of the machine. In this way, each fibre is combed at both ends, and all fibres below a certain length are eliminated from the long fibres, besides all the impurities still in the cotton, being extracted.

In Figs. 115 and 116 are given perspective views of the front and back respectively of the comber as built by the Whitin Machine Works.

The general appearance of the machine resembles somewhat the ribbon lap machine, that is, it has six (or in some instances eight) laps fed to it at the same time, each lap being treated by a separate head,

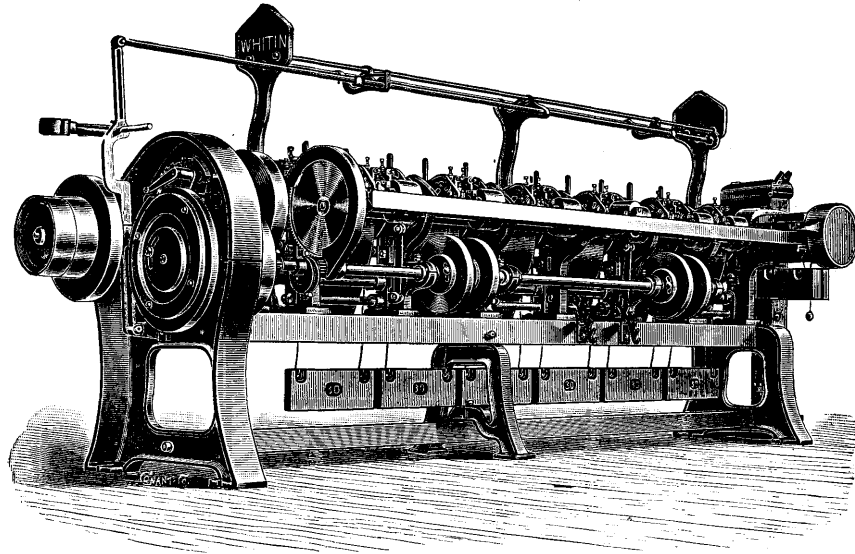

FIG. 115.
FRONT VIEW.

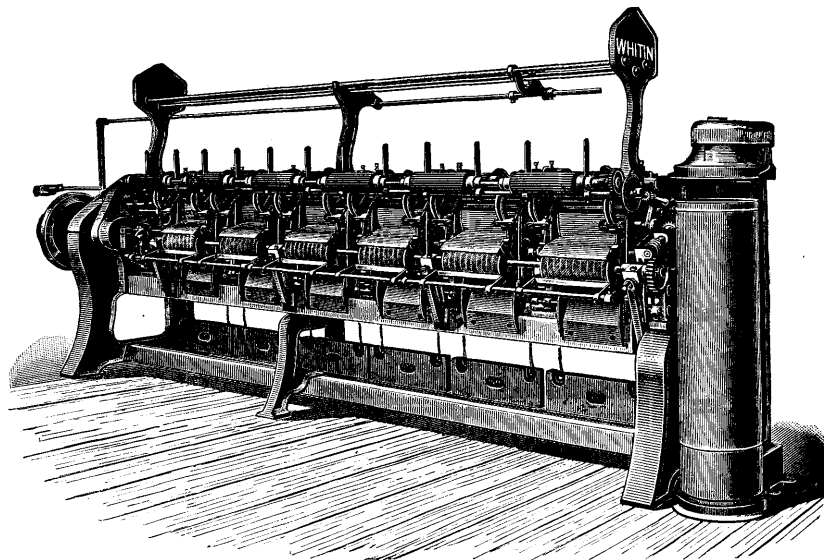

FIG. 116.
BACK VIEW.

the combed laps from all the heads combining in the form of a single sliver at the coiler end of the machine. Lately combers with 10 heads have been brought into the market, the same in this instance delivering to two (2) coilers, i. e., five heads to each coiler, a feature having greater production for its object. All of the heads of one machine are connected and are driven from one end.

Description of the Course of Cotton Through the Machine.—The lap prepared on the ribbon lap machine is placed upon corrugated wooden rollers, at the back of the comber, the same being driven directly by means of the friction between the lap and the rolls; the lap thus unwound passing down a polished plate to the feed rolls. The revolution of these feed rolls is intermittent, and the lap is thus passed through, in short lengths, at intervals, to the nippers. When the rolls deliver the short length of lap, the nippers are open to allow it to pass through, and then close upon it and hold it while the portion which was passed through, is being combed by a set of combs on the cylinder coming around under the fibres and passing through them. The needles on the cylinder occupy about one quarter of its circumference, and on the opposite side from the needles is placed a fluted segment, which comes up under the fibres after they have been combed by the cylinder combs. At the same time a leather roll descends upon the cotton, so that by the revolving contact of this leather roll (called the leather detaching roll) and the fluted segment of the cylinder, the cotton is passed forward, the nippers at this time having opened and released the back ends of the fibres. At the same time that the leather detaching roll descends upon the fluted segment of the cylinder, the top comb is brought down into the path of the fibres, and as they are passed forward, the back ends pass through the needles of the top comb, and thus the entire length of the staple receives a thorough cleaning. The fibres thus detached and combed out, are now attached to those previously combed, by means of the leather detaching roll, a steel roll and a short top roll, making a continuous combed sheet of the cotton under operation, which is condensed into the form of a sliver and passed through the draw box, with the other sliver, to the coiler can. The waste taken out by the top comb is dropped on the projecting fibres from the nippers and in turn carried away by the bottom cylinder comb, as it comes under the fibres directly afterwards. This comb is stripped of waste by a brush revolving at a quicker speed than the cylinder. A doffer then takes it off of the brush, which is in turn stripped by a vibrating comb.

General Description of the Working Parts of the Machine.—In order to show the relative positions of the different parts of the machine, and to enable the course of the cotton to be more satisfactorily followed through the machine, a cross section of the working part of the machine is given in Fig. 117.

The lap is placed on the fluted wooden rolls *O*, at the rear of the machine, which are driven intermittently through gearing from the end

of the feed roll and deliver the lap at the same time that the feed rolls are passing it through to be combed. By means of this drive, the time of delivery is always correct, while if it received its movement from some other source, a special setting and timing would have to be given to it to correspond with that of the feed roll. From the fluted wooden rolls *O*, the lap is passed down a polished slide to the feed rolls *K L*. These rolls deliver the lap intermittently, and in short lengths, to the nipper and cushion plate *T* and *R* respectively. The nipper *T* presses firmly against the cushion plate *R* and holds the tuft of cotton firmly between them, while the comb portion *A'* of the cylinder *C* passes

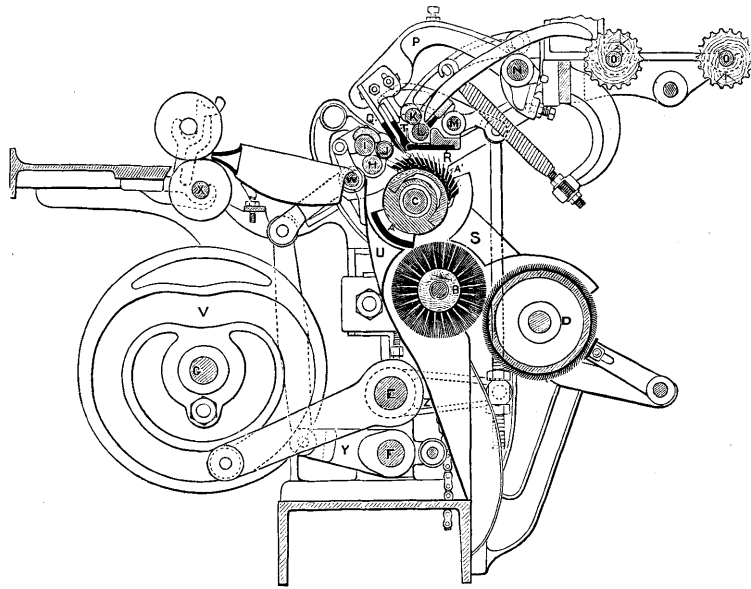

FIG. 117.

through the fibres and removes all short fibres not gripped by the nippers, as well as any impurities in that part of the lap being combed. Just as the combing action of the cylinder is completed, the roller motion, consisting of the rolls *H* and *I*, are turned backward a part of a revolution, which brings back the ends of the fibres previously combed. At the same time the fluted segment *A*, of the cylinder, comes under the combed fibres, and the leather etaching roll *J* comes down on the fluted segment, so that the combed ends of the fibres are thus gripped and taken forward, overlapping the ends of the previously combed fibres, to thus form a continuous fleece. As the fibres are carried forward, the top comb *Q* descends into the path of the fibres, the back ends of which are drawn through the needles of this comb, thus subjecting the whole

length of the fibre to the combing action. The amount turned back by the detaching rolls is about half what is brought forward, so that a continual fleece is passed on through the triangular shaped pan at the front of the rolls *H I*, being in turn converged by a trumpet at the front of the pan into a sliver and from there passed through a pair of calender rolls *X*. From these calender rolls the sliver passes on to the front table of the comber and in turn with the other slivers, made in a similar way, enters the draw box and from there is coiled into a can.

The waste from the cylinder is removed by a brush *B*, which in turn is relieved of said waste by a doffer *D*, the doffer comb in turn removing it from the doffer. It is then wound up in the form of a lap, or in some mills allowed to drop into a waste box.

Of the remaining letters of references in our illustration, *W* indicates the small lifter shaft, *U* the waste chute, *E* the nipper shaft, *F* the large lifter shaft, *Z* the nipper shaft lever, *Y* the lifter shaft lever, *G* the cam shaft and *V* the nipper cam.

It will have been noticed from the general description of the machine thus far given that most of the motions of the comber are intermittent and are of such a character that they are almost entirely dependent on each other for the proper working of the comber, so that any variations from the correct timings and settings of the different parts, would prevent an economical manipulation of the machine, if any results were obtained at all.

The method of obtaining the several operations of the comber will now be discussed in detail in their proper order of dealing with the cotton, and are: (1) Feeding, (2) Nipping, (3) Combing, (4) Detaching and Attaching, and (5) Delivering.

(1) **Feeding.**—This motion is used to feed the proper amount of the lap to the cylinder comb, and this at the proper time. The action of the motion is intermittent, a certain length, which is governed by the length of staple, of the cotton under operation, being fed to the nipper, when then the feed motion remains stationary while the length fed is combed and detached. This intermittent motion is obtained by means of the mechanism shown in Fig. 118, which consists essentially of the star wheel *A* and the disc *B*, with a stud *C* fixed on it, and gearing into the star wheel *A*. *D* is the cylinder shaft, being driven from the main pulley through gearing to the large wheel *E*. On this gear wheel *E*, the disc plate *B* which carries the stud *C*, is placed. The star wheel *A* is situated a short distance from the cylinder shaft and in such a position that the stud *C* can easily gear into it. On the same stud with the star wheel is a gear *F*, which gears into a wheel *G* on the feed roller *H*. The star wheel *A* is made with five teeth and five spaces, as will be readily seen from the illustration. The pin *C* only comes in contact with the star wheel *A* during part of its revolution, the star wheel remaining stationary when the stud is not in gear, through one of the concave portions of its outer circumference being in contact with a circular

portion of the boss *I* on disc *B*. Every time the stud *C* comes around, it turns the star wheel *A* one fifth of a revolution and which by its gearing, transmits this motion to the feed roll, the proper amount of lap

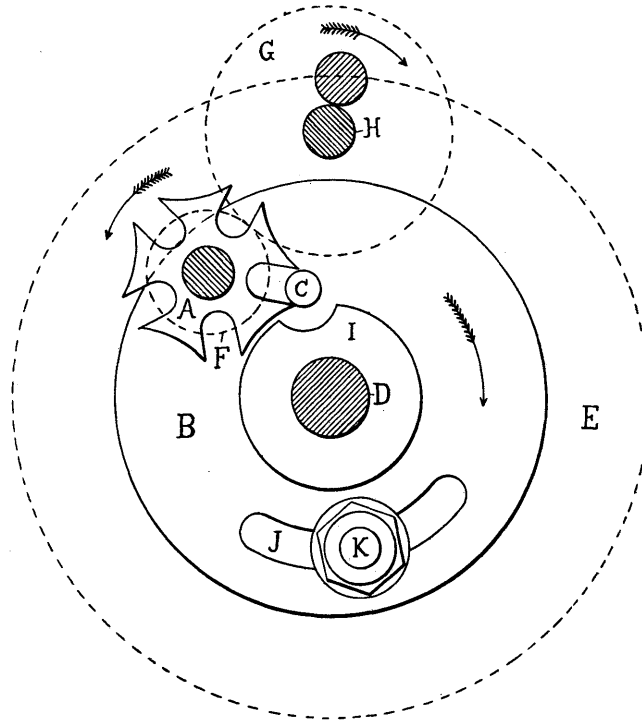

FIG. 118.

thus being delivered. Gears *F* and *G* are used to accommodate the machine for different length of staple of cotton, as the amount to be delivered each time depends on the length of the fibre to be combed. This is readily obtained by interchangeability of the wheel *F* with larger or smaller gears, according as the amount to be fed requires. It is very important in combing that the feed rolls should deliver the lap just as the fluted segment grips the combed ends of the fibres, and in order to make this delicate adjustment, the disc *B*, which carries the stud *C*, has a concentric slot *J*, with a bolt *K* fitting into it and fastened to the large gear *E*. By means of this slot and bolt, the point of contact of the stud with the star wheel can be set to suit any required staple to be combed.

The lap of cotton is sometimes broken in its passage to the combing mechanism and winds around the feed roll, to such an extent that some

of the parts like nipper bars, half laps, etc. are broken before the operative can stop the machine. To overcome this difficulty, a feed roll stop motion is made use of, the object of it being to stop the rotation of the lower feed roll as soon as possible after the delivery of the lap is interrupted by the winding of the lap on the feed roll, which is accomplished by having the feed roller gear automatically move out of mesh with the driving gear when the winding of the lap occurs.

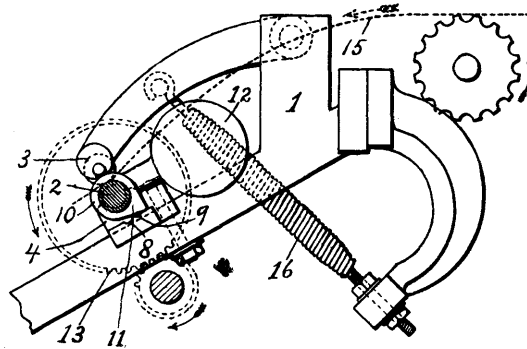

FIG. 119.

The method of operation of the stop motion is shown by the accompanying illustrations Figs. 119 and 120, and of which Fig. 119 is a view, partly in section, taken transversely through one of the sections of a comb, showing the feed rolls and the safety attachment connections. Fig. 120 is a longitudinal skeleton view, showing the principal

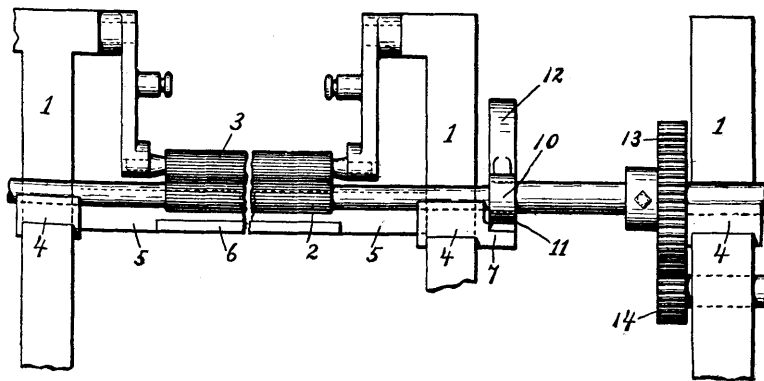

FIG. 120.

features of the motion. A description of the operation of the motion is best given by quoting numerals of reference accompanying the illustrations, and of which 1 indicates the end frame of a section of a

comber, 2 the driven feed roll, 3 the top feed roll, 4 the bearings for the driven feed roll which has only the lower half of its circumference encased, and 5 is the bar on which the cushion plate 6 is supported. One of the bearings 4 has the extension 7 provided with the notches 8 and 9, and on the driven feed roll 2, above the extension 7, is placed the loose collar 10, provided with a pawl 11 which is shaped so as to engage with the notches 8 and 9. To the collar 10 is also connected the counterweight 12. In its normal condition, the pawl 11 on the collar 10 bears on the extension 7 and supports the counterweight 12 in the raised position. Secured to the driven feed roll shaft near its end, is the gear 13 which is driven by the pinion 14, thus giving rotation to the feed roll 2. The lap of cotton is indicated by a dotted line 15, and when it breaks and laps around the feed roll 2, the cotton will be crowded between the bar 5 and the cushion plate 6 so quickly and so tight that frequently these parts, and particularly the cushion plate, are broken. The counterweight 12 somewhat counteracts the tension of the coiled springs 16, which hold the top roller in contact with the bottom roller, so that when the lap winds around feed roller 2, and causes the shaft to rise in its journal bearings, the counterweight 12 causes the pawl 11 to engage first with the notch 9 and then with the notch 8, in this manner lifting the shaft of the driven feed roll further up and disengaging the gear 13 from the pinion 14 and thus stopping the feed rollers until the operator stops the machine.

(2) **Nipping.**—As we have seen, a portion of the lap, after being delivered by the feed rolls, passes through the nippers. The essential use of nippers (see *T* and *R*, Fig. 117) consists in holding the cotton fibres firmly, and in such a position that they are well within the range of action of the needles composing the rows of combs fastened in the periphery of the revolving cylinder. The nippers grip the rear extremities of the fibres while the cylinder needles pass through the front portions of them. This of course allows only a partial combing of the entire fibre, the other portion being taken care of by another motion, as will be explained later on. Although the two pieces (*T* and *R*, Fig. 117) together are called nippers, when spoken of separately the top piece *T* is known as the nipper knife, while the bottom one *R* is called the cushion plate. There are several styles of nippers in use, an illustration of their construction being given in Figs. 121, 122 and 123. In the oldest style, shown in Fig. 121, the cushion plate *A* is covered at the end by a piece of leather (see cross shaded portion), and the nipper knife *B* made in such a shape that it partially fits over the nose of the cushion plate, so that the cotton that is passed between them, is held firmly and this without injury to the fibres. However a disadvantage to this device is that when the leather covering wears out, the cushion plate has to be taken off, and afterwards reset, while in the style as shown in Fig. 122 the nipper knife *B* has a piece of leather (see cross shaded portion) inserted into it at the point of contact with the cushion plate *A*. When

in this construction the leather in the nipper knife *B* wears out, although this is very seldom the case, it can easily be replaced without disturbing the cushion plate.

Another arrangement recently devised is shown in Fig. 123, in which instance the cushion plate *A* is similar in construction to the one shown in Fig. 121, the improvement consisting in a new nipper knife. The flange *B*, also called the "lip," of the nipper knife *C* is detachable

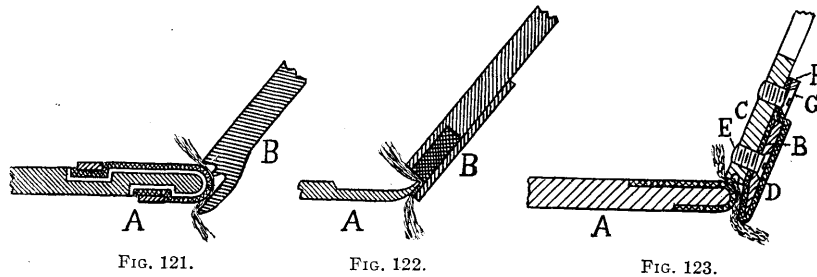

FIG. 121.

FIG. 122.

FIG. 123.

from the nipper knife, and is covered with a piece of leather *D* by having one end of said piece of leather secured between the lip *B* and the nipper knife *C* by means of a screw *E*, which is countersunk into the lip *B*. The leather is then brought around the point of the lip and up over its face, and is secured at its other end by means of the strip *F* and the screw *G*. The advantage claimed is that the end of the lip *B* can be set closer to the cylinder combs, for the reason that if from any cause the needles strike the lip, they will simply pierce or cut through the leather covering without injury to said needles, while on the other hand, if iron were only used, the lip would have to be set farther away from the cylinder, in order to prevent any possible chance of the needles striking the lip, because of the injury which would result to the needles in case they came in contact with the iron lip. By thus having means provided for a closer setting of the lip, the portion of the lap to be combed can be brought closer to the action of the cylinder needles, thus permitting a thorough combing in connection with a greater production, owing to the fact that a heavier lap can be successfully combed.

The method of operating the nippers is shown in Fig. 124. The top nipper *A* is fastened to one end of the lever *B*, as centered at *C*. To the other end of said lever is connected a vertical rod *D*, by means of a joint *E*. The lower end of this vertical rod *D* is screwed to the lever *F*, as centered at *G*. Also centered at *G* is another lever *R*, which carries a bowl *H*, which slides in the groove *I* of the nipper cam *J*. This groove *I* is so shaped that it gives an upward and downward movement to the bowl *H*, which in turn is transmitted to the nipper *A*, through the lever connections just explained. During part of the revolution of the nipper cam *J*, it holds the nipper *A* up and out of contact with the

cushion plate *K*, then during another portion of a revolution of the cam, the nipper is made to descend, due to the shape of the cam, and grip the cotton with the cushion plate, thus holding it until the combing action is completed, when it rises again to let the combed fibres pass forward. The cushion plate *K* is attached to the frame as centered at *L*. The

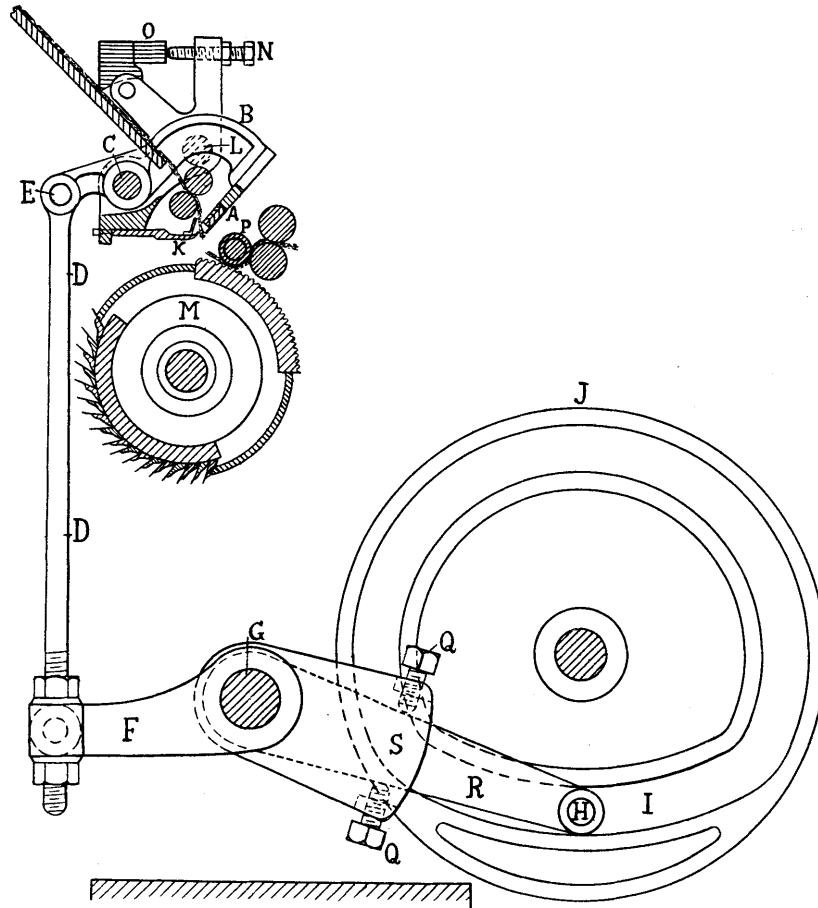

FIG. 124.

fulcrum *C* of lever *B* is also in this frame the latter being kept in its highest position by means of a strong spring attached to it and also connected to the framing of the machine. When, by means of the mechanism thus explained, the top nipper is pressed down against the cushion plate and thus grips the cotton, it has not reached its lowest

point, but continues going down, thus causing the cushion plate *K* to descend with it, the cushion plate moving in the arc of a circle having *L* as its centre. This bodily movement of *A* and *K* brings that portion of the cotton which is to be combed, very close to the cylinder *M* and enables the needles of the comb to pass through it closer to the point where the fibres are gripped by the nippers than if *A* and *K* had remained stationary after gripping the fibres. After the needles pass through the fibres, the nippers begin to return to their original position, being still in contact with each other. When the cushion plate reaches its normal position it stops, while the nipper knife continues its movement up to its raised position, thus freeing the fibres which had been gripped. Thus it will be seen that the fibres are brought up off of the cylinder before the nippers separate, so that when the fibres in turn are taken forward by the detaching mechanism (which will be dealt with later on) the back ends are up high enough to pass through the needles of the top comb. The position of the nipper knife requires a very delicate adjustment, and is regulated by means of the setting screw *N* passing through an arm on the frame which bears against a portion of the framing of the machine as shown by the shaded section *O*. An arrangement of this kind is very essential, because, if such were not the case, the cotton, after being combed, would remain on the surface of the cylinder, in which position it would be impossible to obtain any combing action from the top comb and hence, would give only a partial cleaning to the cotton compared to results as obtained from the operation. By raising the two nippers bodily with the cotton, away from the cylinder, we put the combed fibres into such a position where they are obliged to pass through the top comb as they are taken forward by the detaching roller *P*.

From the description given of the function of the nippers, it will readily be understood that their position in relation to the cylinder is a very important matter and must be looked after. In order to regulate this position, adjusting arrangements are provided to obtain the necessary position, as shown at *Q* and also at the lower part of the vertical rod *D*, where it is connected by a swivel joint to the lever *F*. From these points the exact movement of the nipper knife *A* can be regulated. By means of the screws *Q* the lever *R* can be moved up or down, and the piece *S*, being fast on the shaft *G*, acts with lever *R* as a single lever, when the two screws press against *R*. This contrivance facilitates accurate and delicate adjustment when the nipper cam is being set.

(3) **Combing.**—The fibres, now being held in the proper position by the nippers, are acted upon by the combs on the comber cylinder, which consists of a cast iron cylinder bolted on to the cylinder shaft, the circumference of which is divided into four parts, called respectively the half lap or combing segment, the fluted segment, the two intermediate portions being filled up with strips of tin called the tin segments. The half lap or combing segment consists of a number (generally seventeen) of brass strips running the full length of the cylinder, and having soldered

on their edges rows of needles. These needles in the combs are set at an acute angle with the circumference of the cylinder, so that in moving them through the tuft of lap projecting from the nippers, they have a tendency to draw the fibres down to the base of the needles, which being thicker at the base than at the point, form a series of V-shaped grooves which retain the bunches and neps extracted from the cotton by the needles. The first rows of combs on the cylinder are coarse, the succeeding ones, gradually getting finer until the last ones, which are very delicate. The first comb has about 30 to 32 needles per inch, while the last one, as a rule, has 88 needles per inch, and in many instances as high as 100 needles per inch. This arrangement allows the fibres to receive a gradual treatment by the combs, one row in turn preparing them for the next row, a feature which in its effect is not only a great benefit to the fibres, but also saves excessive wear of the combs. Any broken needles in the combs can easily be replaced by new ones.

A detailed arrangement of the needles in cylinder comb is thus: First six rows 32 per inch, and 24's wire gauge. Rows 7 to 9, 40 per inch, and 26's wire gauge. Rows 10 and 11, 48 per inch, and 27's wire gauge. Rows 12 and 13, 64 per inch, and 29's wire gauge. Rows 14 and 15, 72 per inch, and 30's wire gauge. Rows 16 and 17, 88 per inch, and 33's wire gauge. The fluted segment consists of a cast iron plate, whose surface is concentric with that of the cylinder, and is fluted or grooved along its length, parallel to the feed and detaching rolls. The tin segments, being merely for the purpose of filling up the portions of the cylinder which would otherwise become receptacles for dirt and fly. The top comb consists of a flat steel plate containing a row of fine needles along its edge, bolted to two arms, which are oscillated by a shaft running the length of the machine and operated by a bowl and cam.

The operation of combing is as follows: The portion of web protruding from the nipper, and being held by the same, is on the deflection of the nipper presented to the action of the seventeen rows of needles on the cylinder, which thus comb the major part of the fibre. On the nipper resuming its normal condition, the combed fibre is lifted clear of the cylinder, and is caught between the fluted segment (which by the revolution of the cylinder is brought under it) and the leather detaching roll. Simultaneously with this action, the nipper knife ascends, thus releasing the fibres, and the top comb descends into the fibres just in front of the nipper. By this means, as the cylinder and detaching roll revolve, drawing the fibres through the top comb, their uncombed ends, which were held by the nippers, are submitted to the combing action of the needles in the top comb, thus combing the whole of the fibre.

It may be mentioned here that the front ends of the fibres are technically termed the "heads," while the rear ends are known as the "tails." Owing to the setting of the nippers, only about one-half of the length of the fibres is combed out by the cylinder comb. The extreme front ends of the "heads" of the fibres receive the greatest combing action from said cylinder combs, the amount of combing decreasing toward the

nippers, for the reason that the needles do not pass entirely thoroughly through that part of the fibres close to the bite of the nippers. In order to secure the best results from the cylinder comb needles, the exact position in which the nippers hold the fibres in relation to the centre of the cylinder must be carefully considered, since provided the fibres are held too far back, it is impossible to comb all of the "heads" of the fibres. "Set the needles of the comb cylinder so that if one row misses the fibres, a succeeding row will operate upon them."

In order to get the "tails" properly combed, have the top comb drop as near as possible to the detaching rollers, lifting at the same time the bite of the nippers as high as possible. It will be seen that the revolution of the cylinder comb is constant, while the combing action is intermittent, owing to the periphery of the cylinder being only partially fitted with combs. The "tails" of the fibres in being carried forward to the attaching rolls have necessarily to be pulled through the top comb, this comb acting like a filter, preventing any neps, short fibres or impurities from passing into the combed film.

(4) **Detaching and Attaching.**—Immediately after the cylinder has passed through the fibres, the latter are automatically taken forward and joined to those previously combed. To do this, they must first be detached from the lap and then attached to other combed fibres. From this it will be seen that detaching must precede attaching in the correct sequence of operations, but, however, before either operation takes place, the rear ends of the previously combed fibres must be returned a short distance in order to enable the fibres which will be detached from the lap, to overlap the ends of the fibres thus returned and be attached to them in such a manner as to produce an even film from the fibres thus treated. After the fibres have been returned, the detaching and attaching takes place almost simultaneously.

The attaching is performed by the same rolls as the fibres are returned by, so that an explanation of the working of the rolls will include both movements, although it must be kept in mind that detaching properly comes between them. The mechanism which actuates the rollers to return the ends of the fibres is known as the "roller motion."

There are two types of roller motions commonly used, viz., the notch wheel arrangement, as used on American machines and some English machines; and the quadrant motion, which is used principally on English makes of machines.

The notch wheel arrangement is illustrated in Fig. 125, which is a side elevation of the motion, showing the principal parts necessary for the operation. The arrangement consists essentially of the notch wheel *A* and the two cams *B* and *C*. The cam *B* is grooved and carries the bowl *D* which is attached to one end of the lever arm *E*, said lever being centered at *F*, and having its other end pivotally joined to the lever finger *G*, which carries at its other end a square end projection *H* which fits into the notches of the wheel *A* and moves it in either direction.

On the same lever *G* is attached one end of a spring *I*, the other end of which is attached to the lever *E*, near its top end. The object of the spring is to keep the notch lever firmly in contact with the notch wheel when the cam *C* allows it to enter a notch. On the same shaft with the notch wheel *A* is a gear *J*, which is in gear with a wheel *K* on the end of the steel roller *N*. The cylinder is indicated by *O*, its direction of rotation being shown by arrow.

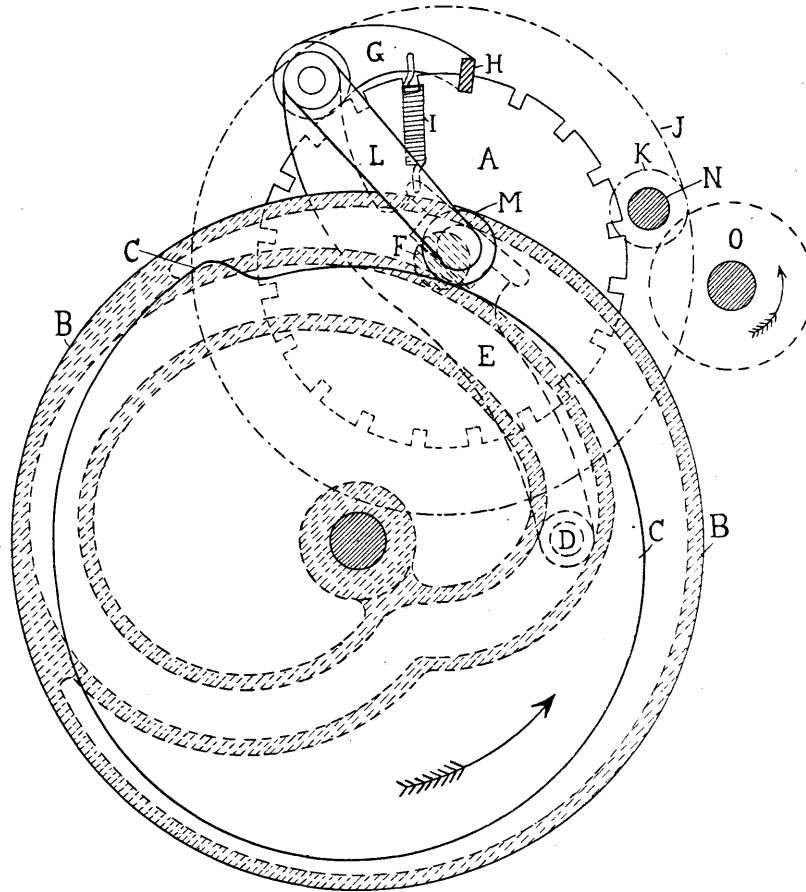

FIG. 125.

The lever *E* is given a backward and forward movement by means of the characteristic shape of the cam *B*, in which the bowl *D* slides. These movements are in turn given to the lever finger *G*, which when it is in contact with the notch wheel *A* transmits the same motion to it and

through the gears *J* and *K* to the steel roll. The time of contact of the finger *G* with the notch wheel is controlled by the arm *L*, which carries a bowl *M* at its other end, and which in turn rests upon the cam plate *C*. As the bowl *D* approaches the centre of the cam *B*, the end of the lever *E* is moved in a right hand direction. At the same time the bowl *M* is nearest the centre of the cam *C*, so that the finger *H* is in contact with the notch wheel, and which in turn is partially revolved by the action of the lever *E*. This movement causes the ends of the fibres to return a short distance, and when the bowl *D* begins to recede from the centre of the cam *B*, immediately after returning the proper amount of fibres, the bowl *M* still being nearest the centre of the cam *C*, causes the notch wheel to revolve in the opposite direction, and consequently the steel roll revolves similarly, and in turn delivers the newly combed fibres into the triangular shaped pan in front of the rolls. Resting on the steel roll *N*, are two other rolls (not shown) held there by springs, being revolved by the frictional contact with said steel roll. The top roll is called the top detaching roll, and the other is the leather detaching roll. The cotton in being carried forward, passes first between the leather detaching roll and the steel detaching roll and then between the top detaching roll and the steel detaching roll into the pan mentioned.

The quadrant motion for performing the same operation is illustrated in Figs. 126 and 127, the principal features of the motion being the quadrant, quadrant cam, and clutch on the end of the steel detaching roll. With reference to Fig. 126, *A* indicates the quadrant cam on the cam shaft *B*, and *C* the quadrant, centered at *D*. The latter is so named because it has two arms holding a segment *H* of a circle on which teeth have been cut, forming almost a quadrant of a circle. On the end of the lower lever arm *E* of the quadrant is a bowl *F* which slides in a groove *G* of the cam *A*. The comb cylinder is indicated by *I* and its direction of rotation by arrow. *J* indicates a portion of the framing of the machine, *K* and *L* are the nipper shaft and the large lifter shaft respectively, of the comber (see corresponding letters of references *E* and *F*, in Fig. 117). The toothed segment *H* works into a gear *M*, collared on the shaft *N* and having at its end one-half of the clutch *U* (shown in Fig. 127), the other half of the clutch being attached to the end of the shaft *N*, which is a continuation of the steel detaching roll *O* (not shown in Fig. 127). *P* and *Q* in Fig. 126 indicate respectively the top and the leather detaching rolls, resting on the steel detaching roll *O*. On the other side of the gear *M* and on the same collar, is a circular groove *R* in which a small projection from the lever *S* fits. This lever *S* is centered and has its other end sliding in the groove *T* of the cam *T'*. Through this cam and lever arrangement the clutch *U* is either thrown in or out of clutch, causing the steel detaching roll *O* to partake of the same motion as the gear *M*, when it is in clutch and to remain stationary when out. As the bowl *F* (see Fig. 126) is moved toward the centre of the cam, the toothed segment *H* is moved upward and being in gear with gear *M*, revolves it. When the clutch *U* is in gear, the steel detaching roll *O* is also revolved.

When the bowl *F* starts toward the outer extremity of the groove of the cam, the toothed segment *H* is moved downward, and the gear *M* revolved in the opposite direction to its first motion. As the clutch is still in contact, the steel detaching roll *O* will also revolve in the opposite direction. The clutch *U* is taken out of contact after the toothed segment *H* has reached its lowest point, so that in rising again, the gear *M* is turned

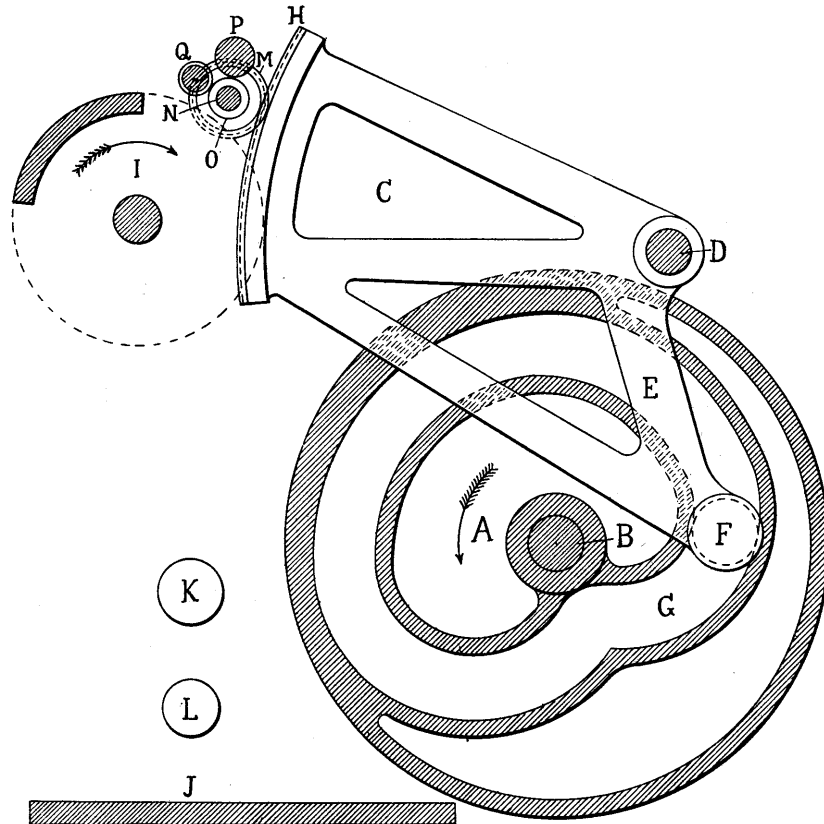

FIG. 126.

without revolving the steel detaching roll *O*, until the clutch *U* is thrown back into contact. The gist of the motion thus explained is to always return a smaller amount of combed fibres for attaching than is immediately carried forward. As was mentioned before, between the returning of the ends of the previously combed fibres and the delivery of the newly combed fibres through the rolls, the detaching operation is performed.

Referring to Fig. 128, an illustration of the method employed in detaching the fibres from the lap is given. *A* indicates the feed rolls, *B* the comb cylinder which has on its periphery a fluted segment, as previously mentioned. *C* is the steel detaching roll, *C'* is the top detaching roll, and *D* is the leather detaching roll. The principal feature of the operation is that the leather detaching roll descends upon the cylinder just as the fluted segment comes under the combed fibres, and the head ends of the combed fibres being between them, as the cylinder continues its revolution, the fibres are thus detached from the

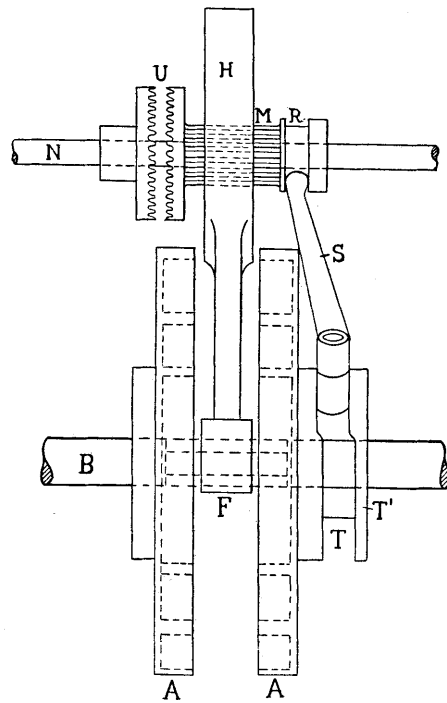

FIG. 127.

lap. The leather detaching roll *D* is lowered and raised by means of the cam *E*, and the levers *F*, *G*, *H* and *I* respectively. Each end of the leather detaching roll *D* is fitted into one of the ends of the lever *I* (one lever on each side) which is centered at *J*, the other end being connected to the vertical arm *H* by means of a joint. To the lower end of the arm is connected in a similar manner the lever *G*, whose other end is fast on the shaft *K*. Connected also to the shaft *K* is the lever *F*, which carries the bowl *L* at its other end, and which in turn slides in the groove *M* on the detaching cam *E*. From the shape of the cam, the lever *F* is moved

slightly up and down at the proper time, that is, for the proper movement of the leather detaching roll. When the end of the lever *F* goes up, the end of the lever *G*, which is connected to the vertical lever *H*, also goes up through its connection to lever *F* by the shaft *K*. The vertical lever *H* is thus moved upward and by its connection with the lever *I*, moves the connected end up. This lever, as mentioned, is centered at *J* so that as one end goes up, the other end which carries the leather

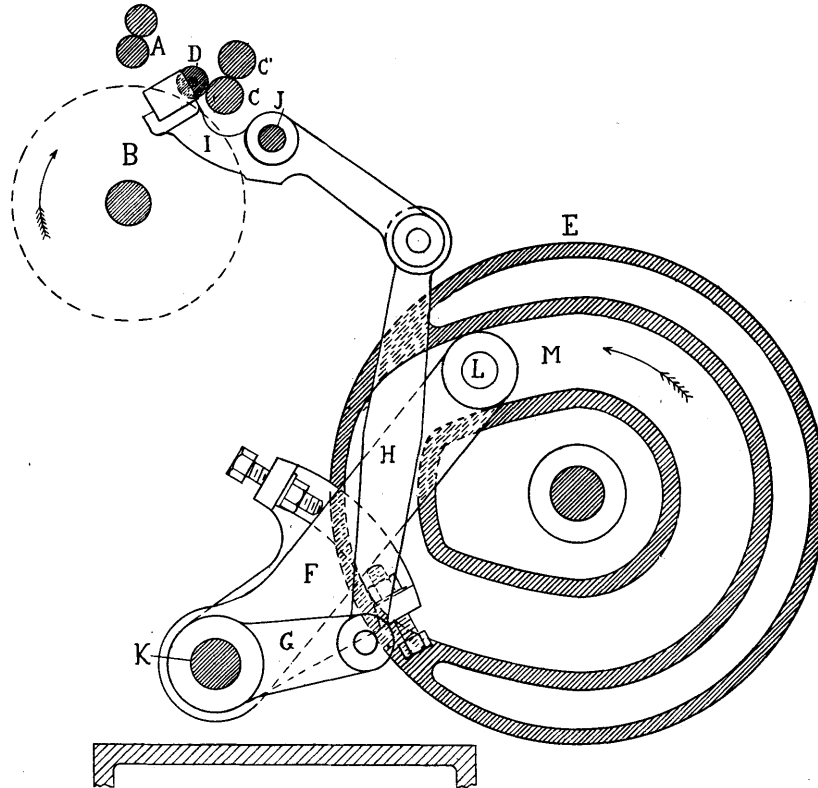

FIG. 128.

detaching roll goes down, thus placing said roll on the fluted segment of the cylinder. It will be noticed that in this position the leather roll receives its revolution from the steel roll and also the fluted segment, so that in order to prevent injury to the leather roll, the surface speeds of the steel roll and the fluted segment must be exactly the same. The cam *E* is so shaped that as soon as the fibres have overlapped the ends of the returned fibres, it causes the leather detaching roll to rise from off the cylinder, in order to be out of the path of the combs as they come around.

Method of Actuating the Top Comb.—It will be remembered that only the front ends of the fibres had received the combing action of the cylinder comb, and now, just as the fluted segment and leather detaching roll pull the fibres forward, the top comb *A* (see Fig. 129) descends and

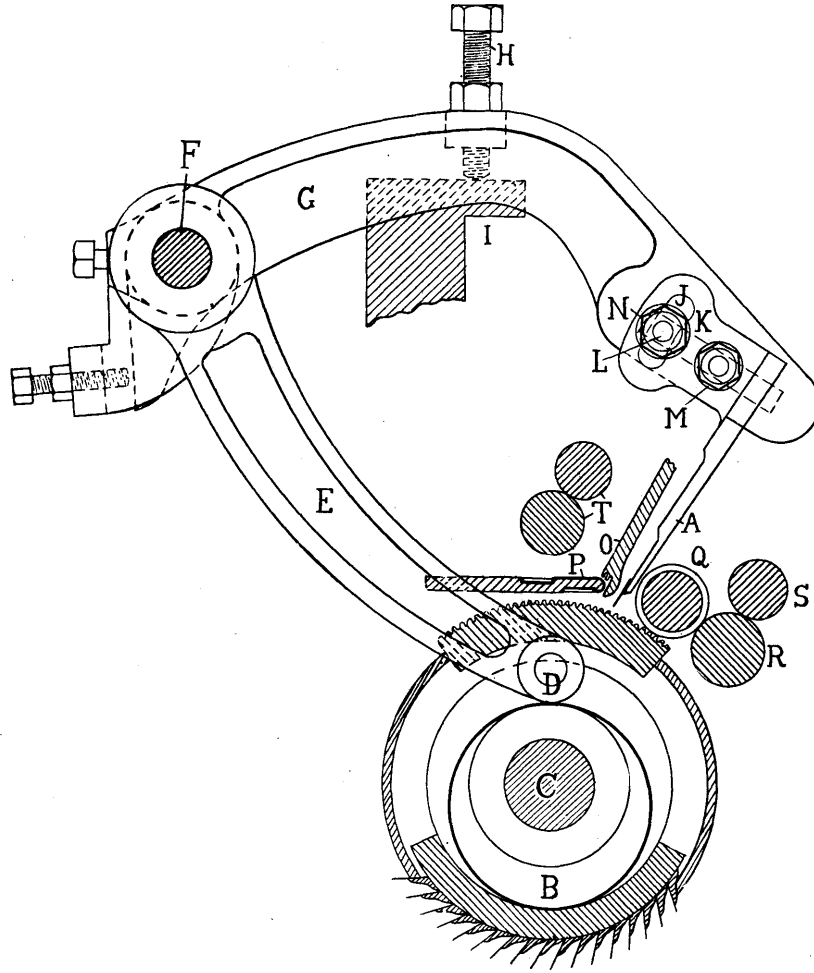

FIG. 129.

the rear ends of the fibres are passed through the needles of this comb, thus completing the entire combing of the fibres. The top comb *A* is operated by means of a cam *B* on the cylinder shaft *C*. Riding on the top side of the cam *B* is a bowl *D* attached to the lower end of the lever

E centered at *F*. Centered also at *F* and connected to the lever *E*, is another lever *G*, carrying the top comb *A* at its other end. When the bowl *D* is nearest the centre of the cam *B*, through the levers shown, the top comb *A* is in its lowest position, that is, the fibres can pass through it as they are taken forward. The outline and setting of the cam *B*, is such that the comb is lowered at the proper time and again raised after the fibres have passed through the needles, in time to be out of the way of the cylinder comb as it comes around. In order to have the comb perfectly parallel, adjusting screws *H* are placed in the top levers *G*, their ends projecting through the lever and resting upon the framing *I* of the machine. These screws prevent one end of the comb from descending lower than the other, a feature which would otherwise cause the fibres to be unevenly combed. The angle of the top comb *A* is adjusted by means of the slot *J* in the arm *K*, and the bolts *L* and *M*. The bolt *M* acts as a centre for the arm *K* and the bolt *L* fits into the slot *J* and is fastened to the arm *G*, and when the nut *N* is screwed up tight, the arm *K* is secured to the arm *G* and the two arms then act as a single lever. *O* indicates the nipper knife, *P* the cushion plate, *Q* the leather detaching roll, *R* the steel detaching roll, *S* the top detaching roll and *T* the feed rolls, all of which parts are shown in their relative positions to each other in the illustration.

A Synopsis of the Operations During Combing.—The descriptions of the actions of the parts of the comber thus far given include all of the principal operations during the actual process, and in order to bring the different movements of the various parts of the comb as more directly connected with the actual combing process clearly to the notice of the student, the accompanying illustration Fig. 130 is given, showing by means of four views, the position of each part of the combing mechanism, as the cylinder takes up the four most important different positions in one of its revolutions.

The first position is shown in diagram I, the combs *A* of the half lap *B* just beginning to comb the fibres. The feed rolls *C* are stationary; the nippers *D E* are gripping the cotton, being in their lowest position; the top comb *F* is in its highest position; the leather detaching roll *G* is in its highest position; the steel detaching roll *H* is stationary.

The second position is shown in diagram II, giving the positions of the parts when the combs *A* are just completing the operation, that is, just leaving the fibres. All of the parts are in the same position as at first.

Between the second and third positions the following movements take place: The nippers *D E* raise, thus liberating the fibres; the top comb *F* descends; the leather detaching roll *G* descends to its lowest position just as the fluted segment *I* comes under it; the steel detaching roll *H* with the top detaching roll *J* returns a part of the previously combed fibres (see dash in roll *H*, indicating the movement of this roll, the top detaching roll revolving in the opposite direction).

The third position is shown in diagram III, the fluted segment *I* having just come under the combed fibres. The feed rollers *C* are just beginning to deliver; the nippers *D E* are up out of contact with each

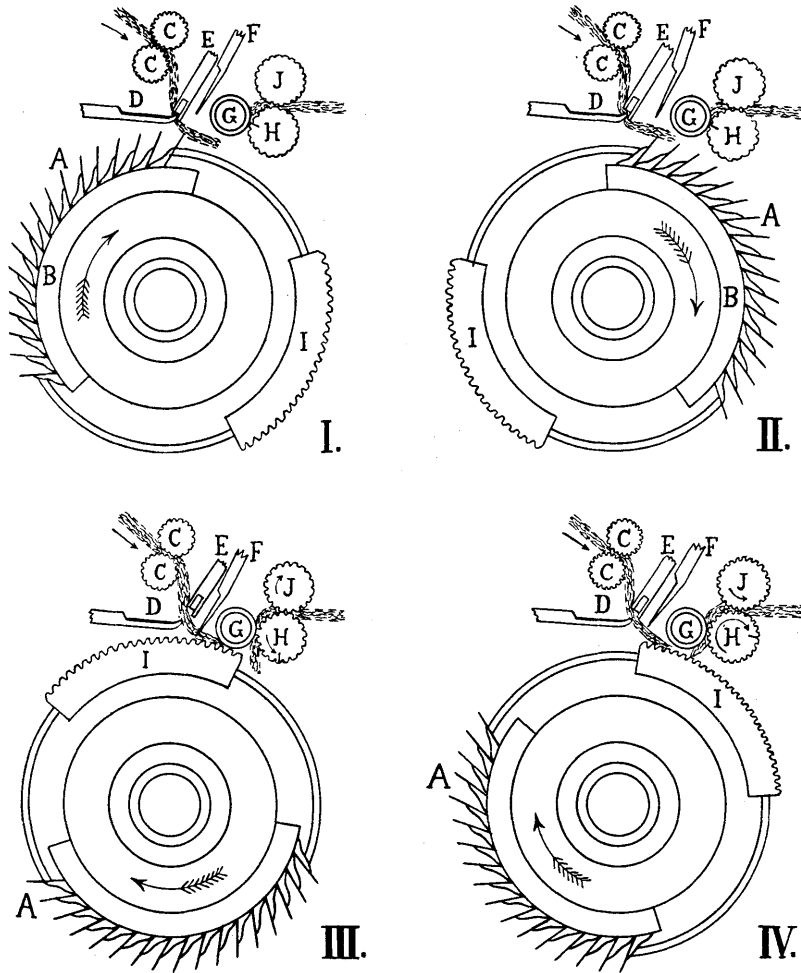

FIG. 130.

other; the top comb *F* is down; the leather detaching roll *G* is on the fluted segment *I* and just beginning to revolve with it and the steel detaching roll *H*, the latter just beginning to revolve in the forward direction.

The fourth position is shown in diagram IV, the fluted segment *I* is just leaving the fibres. The feed rolls *C* are stationary, having just delivered the proper length of lap; the nipper knife *E* is on the point of descending on to the cushion plate *D* to grip the cotton that was passed through by the feed rolls; the top comb *F* is raising out of the way of the cylinder combs *A*; the leather detaching roll *G* beginning to raise up off of the fluted segment *I*; the steel detaching roll *H* just finishing its forward movement. Between the fourth and first positions, all of the movements mentioned in the fourth position are completed and everything is in readiness for another cycle of movements in the comber as was just explained.

The same movements thus explained, are repeated for every nip of the comber, each operation being performed by the different parts as the preceding one completes its work on the fibre.

Referring again to the attaching of the combed fibres to those previously combed, the diameter of the steel detaching roller, whose motion has been described, is say $\frac{7}{8}$ inch, and taking an example of where this roll is given $\frac{7}{8}$ of a forward revolution by the downward motion of the quadrant, we will get a delivered length of combed fibres from the detaching roll after every nip, equal to $\frac{7}{8} \times 3.1416 \times \frac{7}{8} = 2.4$ inches. As the length of the fibres returned is equal to about one half of the length taken forward, the length of cotton fleece returned in this instance will be approximately equal to $2.4 \div 2 = 1.2$ inches. The length returned, however, is usually greater than 1.2 inches, since in some cases the length delivered for every nip is over 2.75 inches. From this it will be seen that the net forward delivery of the steel detaching roll will in most cases be approximately equal to $1\frac{1}{4}$ inches. The length of lap fed by the feed rollers for every nip, is about $\frac{1}{4}$ inch, or about one fifth of the length delivered; which gives a draft between the feed rolls and the detaching rolls equal to $(1\frac{1}{4} \div \frac{1}{4}) 5$.

(5) **Delivering.**—In Fig. 131 is given a top view of the delivery of the combed cotton. The combed film as coming from the detaching rolls *A* passes into the pan *B*, situated directly in front of the rolls. The object of the pan is to keep part of the film in its full width, so that when it is returned through the rollers for the attaching process, it will attach along the entire width. It must be kept in mind that what is said in explaining one head, applies to all heads on the machine, so that on a six head machine, there are six pans, one in front of each head. The cotton at this point in the process is in the shape of a very thin web and is very light. The backward and forward movements of the attaching rolls give the web of cotton in the pan a wavy motion, and as the calender rolls in front of the trumpet have a continuous movement in the forward direction, it will be seen that if the backward movement of the attaching rolls is too far, the web will likely be broken in the pan. Owing to the fact that there is no stop motion on the machine to control such breakages, the combed cotton, when such a break occurs, collects in the pan

until the machine is stopped by the operator and the broken end pieced up. As was mentioned, the web in the pan is very thin, and it is at this place where the work has to be watched to see whether the comber is working properly or not, that is, if all of the neps, dirt, etc., are being properly extracted. Immediately in front of each pan is a trumpet *C* through which the respective film passes and in turn is condensed into the form of a sliver, which is then passed through calender rollers *D*, and from there on to the front table *E*. This front table is a long polished sheet of iron, about 12 inches wide and extending along the entire front of the machine, to the draw box. It is on this table that "bad piecing" shows up most prominently. Bad piecing means that the back ends of the fibres of the previously combed film were not properly joined to the front ends of the fibres of the freshly combed film, that is, the backward movement of the steel detaching roll is either too great or not great enough. In the first instance, the lap will present a lumpy and uneven appearance, while in the latter case, the sliver will be continually breaking or presenting thin places in the sliver. However the breaking of the

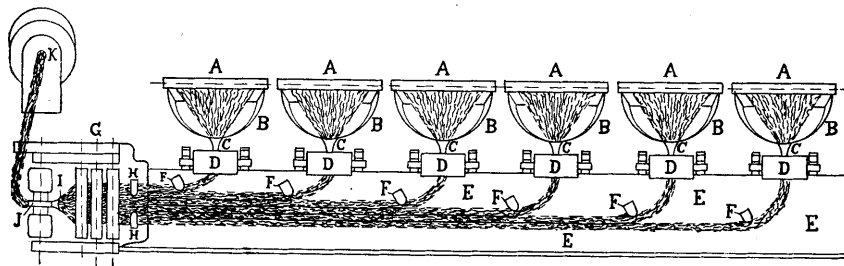

FIG. 131.

sliver is not always an indication of bad piecing, being sometimes caused by having too great a draft between the calender rolls in front of the pan and the back roll of the draw box, a feature which consequently tends to pull the slivers apart in their passage from the calender rolls to the draw box. Guides *F* are also placed on the table in such positions, that the slivers in moving along the table will be laid side by side without any friction on each other, and in this position, enter the draw box *G*. The slivers are drawn from the calender rolls *D* along the table *E* by the rollers of the draw box *G*, being guided to them by the guides *H*. The rolls of the draw box are composed of three sets of drawing rolls. The bottom rolls should be examined frequently to see if they are running easily and smoothly without binding or jumping. Leather covered top rolls are generally used in the draw box, care being taken to keep the front roll, which is usually a shell roll, well oiled and varnished in order to reduce the liability of the sliver sticking to the roll and causing a loss of time in cleaning it off. At the draw box, the second and last large draft on the comber is put in and the six (or more as the case may be)

slivers which are fed to it from the comber heads are delivered as one sheet and then passed through a trumpet *I*, which condenses the sheet into a compact sliver. The total draft between the three rolls in the draw box, will be about 5 or 6, so that the doubling which takes place on the front table, and the drawing which takes place in the draw box, not only make more expeditious handling of the combed slivers, but at the same time help to the production of a more uniform sliver from the comber than would otherwise be possible. Emerging from the trumpet *I*, the sliver of combed cotton is conveyed through the block rollers *J*, which are situated directly in front of this trumpet. The top block roller is quite heavy, while the bottom one is smaller, the former roll being constructed with a ridge running around it at the centre of its width, which fits loosely into a corresponding groove in the lower block roll. The sliver is guided into this groove and in this manner is condensed to a still greater extent. From the block rollers *J* the sliver is passed upwards to the coiler top *K* and coiled into a can in exactly the same manner as on a carding engine, as explained in Vol. I, in connection with that machine.

The drafting rolls used in the draw box, also known as the draw head, consist of three pairs, the diameters of the bottom rolls being respectively 1 inch for the first roll and $\frac{7}{8}$ inch for the second and third rolls. The sliver passing through this machine being very light, it is not customary to set the rolls in the draw box as far apart from each other as in the case explained in connection with the draw rolls in the ribbon lap machine, allowing in connection with the draw box only one sixteenth of an inch over the length of the staple of the cotton under operation, between the first and second pair of rolls, and one sixteenth of an inch gain over this distance between the second and third pair of rolls.

For example if dealing with a $1\frac{1}{2}$ inch staple, set drafting rolls in the draw box as follows: Distance between the centres of the first and second pair of rolls = $1\frac{9}{16}$ inches, distance between the centres of the second and third pair of rolls = $1\frac{5}{8}$ inches.

Lately, combers with double deliveries have been brought into the market, the object being to reduce floor space as well as consequent cost in machinery and their operation. The novelty consists in dividing the delivery of the series of "comber-heads" (from 6 to 10 heads being used) into two sections. The drawing rollers at the delivery end of the combing machine are correspondingly made in two sections, one half of the delivery of slivers (say 3, 4 or 5 as the case may be) passing through each section of said drawing rollers, in turn passing through a separate trumpet and calender or delivery rollers into a separate can. This arrangement, as will be readily understood on referring to Fig. 137 (which is a top plan view of this new delivery, two comber heads being shown in order to explain the arrangement) permits an increased output as compared when using single series drawing and calender rollers in connection with one trumpet between them, and delivering in turn in

one can. The whole gist of the improvement really consists in providing double the number of drawing motions (draw boxes) to a given number of comber heads delivering to it, for which reason the speed of the comber can be considerably increased and the draft diminished, resulting in a greater production of work done without deteriorating the quality of the product. As previously mentioned, a cotton combing machine usually consists of a series of from six to ten heads (two—1, 2—only being shown in our illustration), arranged along the front table 3, and on which the slivers proceed in parallel lines in the direction of the arrows, toward the drawing rollers 4 at the delivery end of the machine. These drawing rollers 4, are made into two sections, and 3, 4 or 5 slivers (as the case may be) passed through each section of the drawing rollers, in turn through a separate trumpet 5, and then through the block rollers 6, each sliver being delivered into a separate can 7.

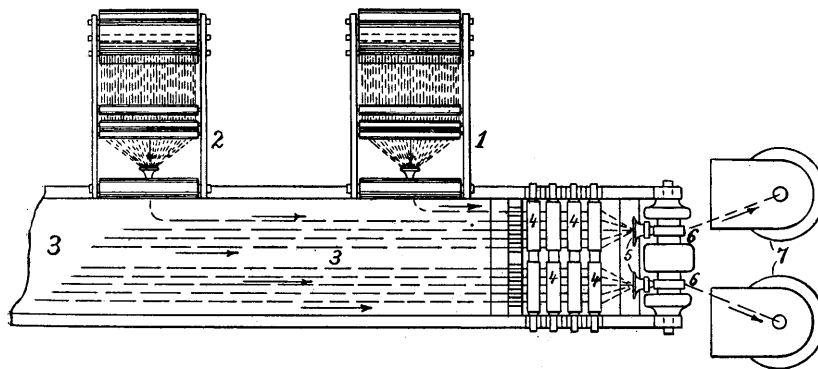

FIG. 132.

Cleaning of the Cylinder Comb.—This is performed by means of the brush *B*, see Fig. 117, the position of which in relation to the cylinder *C* is readily seen from this illustration. This brush is made circular and is set up to the cylinder so that the bristles press into the needles of the combs about $\frac{1}{8}$ to $\frac{1}{4}$ inch. The brush is revolved at a much higher speed (about four times as fast) than the cylinder (rotating in the same direction as the cylinder at point of contact with the latter) in order to thus effectively clean the waste fibres and impurities taken from the cotton, from the teeth of the cylinder combs, in turn reducing to a minimum the possibility of flyings. Although the brush clears the needles very thoroughly, yet it must be understood that in order to keep the cylinder perfectly clean, the various rows of needles must be perfectly joined up to each other, as otherwise spaces would be left between the rows of combs, with the result that waste would accumulate in such spaces, and which not being extricated by the brush would in turn interfere with the proper working of the needles. The diameter of a new

brush is about six inches, but from its continual revolution and necessary friction against the cylinder combs, gradually wears to a smaller diameter and hence performs less effective work. This wear must be taken up by means of re-adjustment of its position and also the speed of the brush, because as the diameter decreases, the surface speed also diminishes. From the brush, the cotton waste is taken off by means of a spiked doffer *D* revolving in contact with it, but at a slower speed for this purpose. The doffer, in turn is stripped of the waste by a vibrating doffer comb as situated on the back side of the doffer, the said waste coming off in the form of a thin fleece or web, which in turn rolls itself up on a slowly revolving shaft, into a handy lap, or as is the case in the older method, the fleece of waste as coming off of the doffer, drops into a suitable box as situated directly under the doffer comb.

DUPLEX COMBERS.—Hitherto only the Single Nip Comber has been referred to, but there are also double Nip, or Duplex Combers built (see Fig. 133, a section of such a comber), whose principal difference

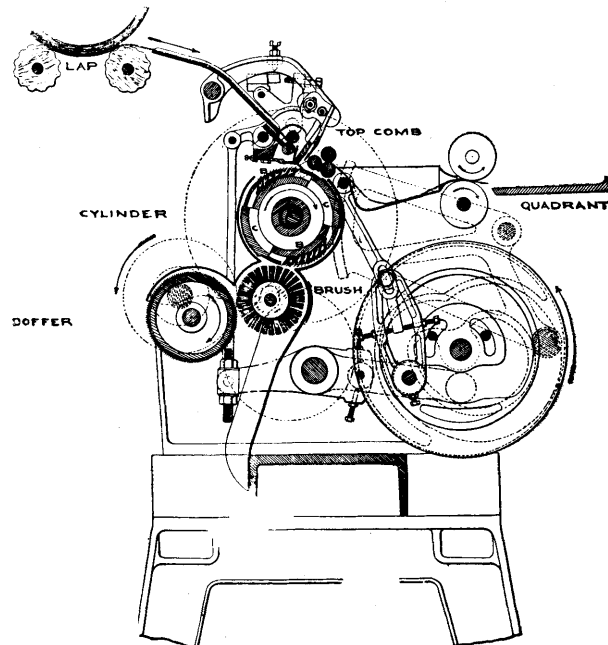

FIG. 133.

from the single nip will only be enumerated, as the motions in themselves are the same.

The cylinder of the Duplex Comber has two separate half laps *B*, containing the cylinder combs, which are set opposite to each other,

and also two fluted segments *C* set similar to the combs, the latter of which in this make of a comber only contain 13 rows of needles each. Whereas before, only one movement of the parts was required for every revolution of the cylinder, now two complete movements are necessary, as the machine must nip twice for every revolution of the comb cylinder. The feed rolls are driven by having two studs opposite each other on the disc (see Fig. 118), which gear in the star wheel, and thus give two intermittent motions to the feed roll for every revolution of the comb cylinder. The movements of the other parts of the comber are obtained by having the cam shaft revolve at twice the speed of the cylinder. A greater production is obtained by the use of the Duplex comber, as the machine can be run at a greatly increased speed, without undue strain upon the parts. The usual speed of a Single Nip machine is from 80 to 100 nips per minute, while the Duplex under ordinary conditions can be run as high as 120 nips per minute. However, the Duplex comber has also its disadvantages compared to the single nip machine, one being that the quality of the work is not as good, since the cotton is acted on by only 13 rows of needles in place of 17 in the single nip machine; the other being that the timing of the various parts can not be done as easily on account of the two half laps and two fluted segments being used in connection with only one cylinder.

Notes on Combing.—Referring to both Single and Duplex combers, it may be noted that the cotton lying between the feed rollers and the nippers is always left in a continuous lap, whereas during the combing operation, underneath the leather detaching roller there is no cotton at all, or at best only a few extra long fibres, hanging from those which have been combed. The forward motion of the detaching rollers, by taking the cotton from the nippers, brings about a complete separation of the combed and uncombed cotton, said nippers closing before the forward motion has been completed. The closing of the nippers in this manner before the completion of the forward delivery of the combed fibres ensures a more satisfactory separation of the combed fibres from the uncombed cotton. While the operation of combing is in progress, the detaching rollers are stationary, so that although the combed ends of the fibres have almost disappeared through the rollers, yet they have not been carried forward entirely, and the next movement of the rolls being in a backward direction, the ends of the combed fibres are returned, ready for the attaching operation. In returning for the attaching, the combed ends of the fibres naturally follow the periphery of the steel detaching roller and the fluted segment of the cylinder, so that they hang down from the former, and can be readily overlapped by the freshly combed portion of cotton, by means of the fluted segment and the leather detaching roller.

In combing short stapled cotton, it is necessary to put a smaller gear on the stud with the star wheel, so as to give the feed roll less rotation, because if for short staple cotton the same amount of lap

would be fed per nip as for long staple cotton, the fibres would be carried forward before they had received sufficient combing from the cylinder needles. Besides being used to facilitate a change of the stock being combed, the gear previously referred to is also practically speaking, the draft gear of the comber, and is changed when it is desired to alter the weight of slivers being delivered, or if the weight has been changed from some cause and it is desired to keep it the same. Say, for instance, that less waste is taken out by the cylinder combs than usual on account of a specially uniform staple, then the weight of the combed sliver would naturally weigh too heavy; consequently by having a change wheel, less lap can be fed, while the same weight as previously obtained will result. Great caution should also be exercised to prevent the leather detaching roller and the top detaching roller from being in contact with each other. On a casual examination of the machine, the two rollers might appear to be in contact, but on further examination they will be found to be slightly separated, as actual contact between them would greatly interfere in the proper delivery of the combed fibres. However the space between them is very small, being only about $\frac{1}{64}$ inch, and care should be taken to have them perfectly parallel, which may be done by the use of a gauge, a No. 19 being the correct one to use. The top detaching roll is usually covered with brass, the advantages claimed being that the cotton is more firmly gripped between the steel and top rolls, the life of the roll also being prolonged. Although leather rolls have been used as top rolls, they are almost all being discarded and in their places brass covered rolls substituted. The set of three detaching rolls in a comber is used simply as a carrier of the combed fibres back and forth, and performs no drafting operation.

Size of Flutes.—The flutes on the steel detaching roll have been the subject for much discussion as to their correct size, that is, whether they should be of a fine or coarse cut. Different sizes have been used, all with favorable results. Mills using fine flutes, put forth in their favor the contention that the sliver made from them is more glossy, with a more perfect piecing, and that there is less liability of producing torn or cut edges on the slivers. Advocates of coarse fluted rolls state that they are much easier to set parallel, exert a better grip upon the fibres being passed forward, and are not worn off as rapidly as the finer flutes.

The principle of the operation by which all the short fibres are taken out of the lap without the extraction of the long fibres, is best given by taking a concrete example of the fibres, and explaining the treatment they receive. Suppose the length of the fibre under discussion to be $1\frac{1}{2}$ inches, and the distance between the point of contact of the centre of the leather detaching roller with the fluted segment of the cylinder to be 1 inch from the top edge of the cushion plate. The length of lap delivered at every nip by the feed rollers is $\frac{1}{4}$ inch, and fully $\frac{1}{2}$ inch has to be projected through the nippers before the cylinder needles can act on the fibres. Before the entire length of the fibre is projected through the nippers, it is carried forward through the top comb

by the detaching motion as combed fibres, so that the cylinder combs pass through said fibres only two or three times, and not about four or five times as is sometimes stated. It will be seen from the above explanation, that the long fibres, although combed separately at both ends, are always held either by the nippers or by the detaching mechanism, so that under proper working conditions, it is almost impossible for a long fibre to be combed out as waste. Suppose now that instead of all of the fibres in a lot of cotton to be combed being $1\frac{1}{2}$ inches, there are fibres of only $\frac{5}{8}$ inch staple amongst them. When the latter project about $\frac{1}{2}$ inch from the nippers, their forward ends will receive the combing action of the cylinder needles once, but as they are projected forward another $\frac{1}{4}$ inch, they leave the grip of the nippers, and as the distance from the nippers to the bite of the detaching roll is 1 inch, they will not be carried forward by the detaching motion, in other words, they are entirely free, except that the surrounding fibres prevent them from dropping out, and consequently, when the needles of the cylinder pass through the fibres on the succeeding revolution of the comb, these short fibres will be caught by the needles and carried around as waste.

Curling of the Fibres.—This is one of the common evils connected with the detaching and attaching mechanism, that is, the sliver presents a curly or wavy appearance as it comes from the detaching rolls. The cause of the trouble is generally found to be that the fibres are too dry, and when not too bad, can be remedied by sprinkling the floor around the combers with water, also by having buckets of water placed under those heads which give the most trouble, and keeping them there over night. Humidifiers would very effectually remedy the evil, but their use is restricted on account of the needles of the combs, as well as such parts of the machine as have to remain very smooth, being easily susceptible to rusting, and when the advantage gained one way would be more than counterbalanced by the damage done.

Regulation of Waste Made.—Aside from the thorough combing of the good fibres in the lap, the next important consideration in the operation of a comber is to regulate the amount of waste or noil according to varying conditions. The amount of waste or noil necessary to be removed from a lot of cotton under operation depends upon the quantity of short fibres in the lap, and as this condition is more or less influenced by the proper carding previously performed, consequently when deciding upon the percentage of noils to be maintained these things must be considered, and the comber adjusted to remove the least amount of waste or noil consistent with the quality of the work desired. Different grades of cotton certainly will contain different quantities of noil or waste, varying from 10 to 30 per cent. As stated before, this percentage must be determined upon and the machine adjusted to remove the required amount, since otherwise a large percentage of valuable stock would be lost as noil, or a large percentage of noil allowed to pass into the sliver and this in turn would deteriorate the yarn. A comber may be adjusted to remove any amount of noil; in fact, it may be so set and timed

that the stock can be run through the machine without removing any noil whatever; however the purpose of this machine is to take out this undesirable material. When cotton is run through the comber, and only a very small amount of noil is removed, it is a sign that the machine has been so adjusted that the needles have not been allowed full play upon the fibres, and as a result only a portion of the noil in the cotton is removed, i. e., only a part of the stock under operation is combed. For this reason it is impractical to remove less than 10 per cent of noil from a lot of cotton. To obtain strength and characteristic appearance of combed yarn, and to take out the same amount of noil from each individual head in the comber, and to maintain this under the varying conditions of the work, requires practice and a close attention to the innumerable details of the machine. Any cotton above the average combing length ($1\frac{1}{4}$ inches) is always more or less neppy, and in order to remove this large amount of neps and all other impurities that do not go to make up a perfect yarn, close settings must be made. This results in a large percentage of fibres which are below the combing length being taken out along with the neps and foreign matter and pass into the noil; while if such a close setting were not required, a large number of these slightly short fibres would pass into the yarn. From the various cottons which are subjected to combing, Peelers and Benders are the most difficult to card and comb, and from 20 to 30 per cent of noil must be expected. This cotton contains a large amount of neps which must be removed, a feature requiring close settings of the various parts of the machine in order to give it every advantage to thoroughly comb the stock. Egyptian cotton, while as a rule clean and consequently easy to comb, generally contains a large percentage of short fibre. This cotton does not require so close a setting, although its unevenness in staple generally results in the production of from 15 to 20 per cent of noil. Sea Island cotton is difficult to comb and in connection with the operation a careful and accurate adjustment of the comber is absolutely necessary, 18 to 22 per cent being the average of noil made consistent with perfect work.

There are several methods employed for the regulation of the amount of noil taken out of the lap, the following items all tending to increase the amount of noil taken out and vice versa, viz., the earlier the comb is dropped, the later the nipper is closed, the greater the angle of the top comb, the later the feed, and the closer the settings. As a matter of fact, the first and second points are hardly ever made use of, since these timings should not be tampered with, as bad work would invariably result. Changing the angle of the top comb might be resorted to by a skilful operator, but as 31 degrees angle is a good rule for setting the top comb, it should only be changed on special occasions. Later feeding can safely be taken advantage of, and the amount of noil produced may be varied by this means safely to the extent of 4 per cent. The feeding operation commences just before the leather detaching roller comes into contact with the fluted segment. By delaying the

feed; the leather detaching roller and fluted segment cannot grip all of the fibres sufficiently well, with the result that those which are slightly shorter are left for the cylinder needles to be taken around as noil.

By the setting of the nipper knife to the cylinder needles, and the top comb to the fluted segment, the amount of noil is also easily regulated, since the deeper the stock is pushed into the path of the needles of the cylinder as they pass, the larger will be the percentage of noil removed, while, if the cotton under operation is not forced sufficiently far into the needles, the same, as they come around, will not pass thoroughly through the stock, and thus have a tendency to leave short fibres in the cotton, a feature which will be at the expense of the quality of the work produced, if this practice is carried beyond the proper limit. By setting the top comb nearer to the fluted segment, the amount of noil removed will also be increased for the reason that the comb will penetrate deeper into the lap of cotton under operation, permitting only those fibres which are gripped firmly by the fluted segment and leather detaching roll to be drawn through the needles of said top comb, and when consequently more of the short fibres will be held back by the comb, to be in turn removed by the cylinder needles on the next cycle of operations; while on the other hand, if the top comb is set so that it does not approach as close to the fluted segment, the fibres will pass to a certain extent, underneath rather than through the comb and hence many fibres will escape its action that would otherwise have been removed. Careful adjustment of the nipper is also a very important point in the regulation of the amount of noil made, for which reason care must be taken that the cushions are as straight as it is possible to get them, also that the nipper knives are parallel and are nipping the entire length of the cushion plates, in order that the stock will be held firmly throughout its entire width, and thus prevent any portion from being pulled out by the cylinder combs and taken around as waste.

The condition of the detaching rolls also affects the percentage of noil made to a considerable extent, those that are uneven or which have been made rough by using a poor varnish and which has come off of the rolls in patches, will necessarily produce an excessive amount of noil.

Where a very heavy lap is used, and combers are driven to their utmost capacity, every advantage possible must be given the needles to perform their work efficiently upon the fibres, which, owing to the character of the lap, will necessarily result in a large production of noil. In order to reduce this percentage without altering the timing and setting of the parts, weights are frequently added to the leather detaching rolls, i. e., 3 or 4 lb. weights are hung on each hook to answer the purpose; but this is not a common practice and is only resorted to in mills where heavy production is demanded. While this plan will do much toward reducing the noil, it is ruinous to the leather detaching rolls and can only be practiced favorably where a wound leather roll is used, as a cotted roll is not so substantial and would be quickly destroyed by the excessive pressure on the steel detaching roll. The fact that a

great many rolls are run several month after having outlived their usefulness, the plan thus mentioned would answer the purpose of getting rid of these bad rolls, which in some instances are run as long as they hold together sufficiently to take another coat of varnish. This practice of using rolls after they are worn out, causes a great many fibres to be left behind which should have been incorporated into the combed film of cotton.

Methods have thus been given for taking the noil and waste out of the fibres, and the next item is to keep them out. Unless the machine is kept perfectly clean, a large part of the good results gotten in the combing process is lost, as it is clear to every one that if the waste is left through carelessness in such a position as to be again incorporated into the fibres which have been combed, no material benefit will result from the expensive operation. Neglect of the comber will very soon be made apparent by the appearance and quality of the yarn spun from the combed fibres, while with care and proper attention to its operation, the yarn produced will be of the highest quality, a result not obtained by any other process in its manufacture.

Settings and Timings.—The keynote to the successful working of a comber is the proper timing and setting of the different motions. To have any one of the motions working out of exact harmony with the others is to sacrifice the efficiency of the machine, and therefore there must be some arrangement by which the timings and settings can be easily and accurately made, otherwise the time and labor of setting the different parts would prove very expensive and could not even then be made with entire satisfaction.

The arrangement used for the proper timing consists in an index wheel on the cylinder shaft. It has 80 teeth and its circumference is divided into 20 equal parts, the divisions being numbered from 1 to 20. There is an index finger which is stationary, and all settings are made by placing the required number on the index wheel under the index finger. The cam shaft is driven from the cylinder shaft by means of another 80 tooth gear, so that the two revolutions are the same, and the cams on said shaft can be set from the index wheel without additional figuring for the proper number.

The settings and timings, as advised by the Whitin Machine Works are given as follows:

Cleaning the Parts of the Combing Machine.—All shafts in the combing machine should be taken out and thoroughly cleaned. All the shaft bearings should also be cleaned before the shafts are replaced, as well as other parts of the machine that may be covered with grease or other preservative.

Setting the Shafts.—It will be found most convenient to replace the shafts in the following order: Lifter and Nipper shafts, $1\frac{1}{4}$ " and $1\frac{1}{2}$ " diameter, running in the base of the upright stands; cylinder shaft, coupling this to the short shaft that carries the index gear; driving

shaft; cam shaft; notch wheel shaft. See that all caps are screwed firmly to their places and that all shafts run freely after the caps are well set up. Put the large gear covers on head end of the machine and see that they do not interfere with the moving parts of the machine.

Setting End Cam.—Put on pawl arm with cam roll on it. Set these caps up hard. Throw 80 tooth gear out of mesh by sliding endwise, and turn cam shaft till the roller in pawl arm is in the heel of the large cam on the end of the machine. Turn the index gear till the number $5\frac{1}{2}$ stands opposite the pointer and slide the 80 tooth gear back into mesh and bolt it to its sleeve.

Fluted and Needle Segments.—See that the fluted segments are screwed down firmly, and then put in needle half laps and screw them down firmly. Be sure and have them thoroughly cleaned. Put small tin casings between the two segments and see that they fit closely.

Lifters to be in Line.—See if the lifter slides on the small shafts are all in a straight line before putting them in place, and also see that these set screws are well tightened. Put brass bushings in detaching roll bearings and place the detaching roll in the bushings. See that this roll and the small lifter shafts are free after the caps are screwed on, they are both under the same cap. Connect the small lifter shafts with the large lifter shaft. The detaching roll should be set to the fluted segments with a No. 21 gauge.

Setting Cylinders.—Put on large tin waste chutes, being particular to have each square and true, particularly at the point where they come between the upright stands. Then set the cylinders in the proper place by turning the index gear till number 5 is opposite the pointer. Then turn cylinders on the shafts till they all stand with the front edge of the fluted segment $1\frac{1}{8}$ " from the back side of the detaching roll. Use the $1\frac{1}{8}$ " gauge to caliper this distance. Screw the cylinders firmly to the shaft by the set screws at each end of each cylinder. See that each cylinder stands midway of the waste chutes, particularly at the point where they cover the ends of the cylinders.

Draw Head.—Put doffer worm-gear shaft in place. Put draw head together and place gears and covers in position and connect with the gear on end of the cylinder shaft.

Setting Top Comb Shaft.—Put top comb shaft in its bearings. Screw on the caps and set 7 inches from the back side of the detaching roll to the front side of the top comb shaft.

Setting Brushes.—Put in the brush shaft and set the brushes so that the bristles will touch the brass faces of the needle bars. Do not set the brushes hard against the needles.

Setting the Nippers.—Put on the cushion plates and adjust them by the small screws at the back, so that the front edge of the cushion plate is the thickness of a piece of writing paper from the lip of the nipper knife. Be sure and have the nipper knife perfectly straight. Fasten the plates securely in place by the binding screws and try the setting after tightening the binding screws. Place the nipper frames all on the

floor and connect them with the nipper stands, and slide the feed roll into place endwise, then lift them together into place. Set the arm (with the stop screws in them) about an angle of 31 degrees by adjusting the stop screws. Then set the front edge of the cushion plate the proper distance from the detaching roll. Use only one screw in each frame to make this setting and when cushion plate is set, fasten the stop screw you have used with the check nut. After all the frames have been set in this manner, set the other stop screw with the one that is set with paper so that both screw points in each end will hit the stand at the same time. Four gauges are used for this, ranging from $1\frac{1}{8}$ " to $1\frac{5}{8}$ ", according to the cotton under operation. While gauging this distance, set the nipper frame up or down until the cushion plate is the thickness of No. 12 gauge from the segment. This is to level the frames merely; they are all reset to the half lap needles later. The nipper knife will now stand at about an angle of 31 degrees. To get more angle on the nipper knife, turn the screws in the upright arm further in. In setting the nippers it is always best to begin in the centre of the machine and work each way.

Setting Feed Roll.—Set front side of the feed roll from the detaching roll $1\frac{3}{8}$ " to $1\frac{5}{8}$ ", that is, if the cushion plate has been set $1\frac{1}{8}$ " to $1\frac{5}{8}$ ". Put on nipper springs and give a tension by screwing the nuts about $\frac{1}{4}$ " after they begin to draw. Feed roll should start when figure four is opposite the pointer. Set the cross shaft from the feed roll to the corrugated lap rolls.

Setting the Nipper Rods.—Connect nipper frames to large nipper shaft. See that rods enter the swivel freely. Turn the comber until the first row of needles on the half laps point to the centre of the detaching roll, or until pointer is at $14\frac{1}{4}$ on index gear. See that the roll is in high part of nipper cam under the sliver plate. Put stop gauge under the point of the stop screw and adjust nuts on connection rods until the pressure is nearly taken off the gauge. At the same time set the nipper frames up or down until the cushion plate gauges No. 19 from the needles. Tighten all bolts and check nuts and try gauges again to see if settings have moved.

Timing the Nippers.—Set the lever that controls the opening and closing of the nippers so that they will open at $3\frac{1}{2}$ and close at $9\frac{1}{4}$ on the index gear. Do this by moving the cam on its sleeve and by the long adjusting screws.

Setting the Top Combs.—See that the tin strip that holds one set of needles, stands about $\frac{1}{32}$ " further down than the fixed needles. Turn combing machine until fluted segment is under top comb needles. Cam should be at its lowest point. Give top comb an angle of about 31 degrees and set it about $\frac{1}{16}$ " from the leather roll. Set dogs on top comb shaft so that all the combs will be lifted at the same time. Gauge combs so that they will stand about 20 gauge from segment. Set cam on end of combing machine so combs will be down when index gear is at No. 5.

Setting Doffers.—Put the doffers in place and set them about $\frac{1}{8}$ " from the brushes. Do not have the doffer wire touch the brush; the waste will be nepped if it does. Set the doffer comb the same relation to the doffer as the doffer is to the brushes. Put the doffer covers on castings, setting them so that they are close to the "bite" of brush and half lap on cylinder, and high enough to throw the waste down. Set them close to the doffer on the back side.

Setting Lap Aprons.—Put in place the aprons that reach from the wooden corrugated lap rolls to the steel feed roll and see that the brush on the end of the apron strikes onto the steel feed roll. Have index wheel at $14\frac{1}{4}$ in making this setting.

Setting the Top Feed Rolls.—Put the feed roll in the bearings and adjust so that the top feed roll is parallel with the feed roll proper. Hook on the springs and give about the same tension as the springs on the nipper frames. Set the wooden corrugated lap rolls to the aprons and adjust the vertical lap fingers so that the lap will feed fair with the aprons.

Setting Lifters.—Put the leather detaching rolls in place. See that the flat side of brass bushings on end of these rolls bears against the lifter slides. Attach the roll weights to the stirrups and hang the stirrups in the bearings made for them in the brass bushings. Turn the combing machine until the segments come under the leather detaching roll. See that roll in lifter cam, under the sliver plate, is in the highest position. Loosen lifter quadrant and throw the lifters up till the No. 21 gauge will go between the brass bushings and the highest lifter slide. Then set all the other slides, individually, till they stand the same as the first one. Make them all secure and see that there is no chance for them to slip back.

Timing the Leather Detaching Rolls.—Place a slip of paper between the lifter slides and the brass bushings and adjust the time to rise and fall by turning the lifter cam on its sleeve, and by the long screws in the quadrant. Have the paper released at $6\frac{3}{4}$, and have the lifter return and tighten the paper again at $8\frac{3}{4}$ on the index gear. The rolls may be left in contact with the fluted segment until $9\frac{1}{4}$ without detriment.

Timing Detaching Rolls.—Adjust the large cam at the end of comber on its sleeve, so that the detaching roll will begin to move forward when No. 6 on the index gear stands opposite the pointer. The revolving motion being given to the leather detaching roll through contact with the steel roll, said steel roll should begin to revolve in the forward direction a little before the leather detaching roll reached the fluted segment, so that there could be no chance for a difference in the surface speeds of the rolls and the fluted segment.

Top Detaching Rolls.—This roll should simply be set parallel with the steel detaching roll and quite clear from the leather detaching roll. Set this roll the thickness of No. 15 gauge from the leather detaching roll.

Draft of Calender Rolls.—Two gears are placed on the cam shaft to drive the calenders, 20 tooth for regular work and 21 in case the sliver

in the conductors does not pick up readily, as in damp weather. Either is in position for convenient use. If these gears are changed, a corresponding change must be made in the gear on the back roll in the draw head. These gears run from 44 to 47 teeth and effect the take up of the sliver on the sliver plate.

Recapitulation of Timing of Parts of Combing Machine.

Nippers open at.....	$3\frac{1}{2}$	index gear.
Nippers close at.....	$9\frac{1}{4}$	“ “
Lifters down at.....	$6\frac{3}{4}$	“ “
Lifters up at.....	$8\frac{3}{4}$	“ “
Top combs down at.....	5	“ “
Detaching roll moves forward at.....	6	“ “
Feed roll moves forward at.....	4	“ “

The foregoing timings and settings are not of an arbitrary nature, but are merely intended as an aid to those whose experience with combing machines is of a limited nature. Experience with different grades of staple will suggest changes which may, with advantage, be adopted in preference to the rules given.

Driving of the Comber.—The driving of the machine will be seen on referring to Fig. 134, which is a diagram of the gearing of the comber shown in Figs. 115 and 116. The position of the feed roll in the diagram of gearing is wrong, but is so placed in order to make the diagram as clear as possible. It will be seen that the feed roll is in front of the cylinder when it should be behind the cylinder. Should the feed roll occupy the position shown in Fig. 134, the cotton lap being fed to the machine would not be acted upon by the cylinder. It must also be understood that the cotton does not touch the brush or doffer, as these parts are below the cylinder, and the cotton is above the cylinder. Referring again to the diagram, we find that on the end opposite from the driving pulley, the driving shaft carries a gear (28) which through an intermediate gear (34) drives the gear (30) on the end of the brush shaft. On the driving shaft and next to the fast pulley is placed a balance wheel in order to prevent any vibration, as far as possible, due to the intermittent motions of the comber. On the same shaft is fixed a pinion (21) which gears into the 80 tooth gear on the cylinder shaft. This 80 gear is meshed with an 80 gear on the cam shaft, thus giving to the latter the same number of revolutions. Near the end of the cylinder shaft is placed a bevel gear (24), having another (24) bevel gearing into it on one side, which in turn drives a shaft with a gear (80) which meshes into a gear (43) on the end of the calender roll in front of the draw box. On the other side of the (24) bevel gear just mentioned, is meshed another bevel (24) on the end of a shaft, the other end of which has a single worm driving gear (32) on the end of the doffer shaft. On the extreme end of the cylinder shaft is the gear (60) which through a train

of gears drives the coiler calender roll. On the cylinder shaft near the 80 tooth gear is the disc, carrying the stud which drives the star wheel (5). On the same stud with the star wheel is the change gear (13 to 20), which through the gear (38) drives the feed roll. On the other end of the feed roll is the bevel gear (23) meshing into the bevel (22) on a shaft having the bevel (20) at the other end, which in turn through a train of gears drives the lap roll. On the stud with the notch wheel is the annular gear (138) which meshes into another gear (18) on the end of the steel detaching, i. e., drawing-off roll. The calender rolls in front of the drawing-off roll are driven through the gear (142) on the end of their shaft from the gear (21) on cam shaft. Another gear (20) is also placed on the cam shaft, and next to gear previously referred to, which can be substituted for the 21 gear in case the tension of the film requires it.

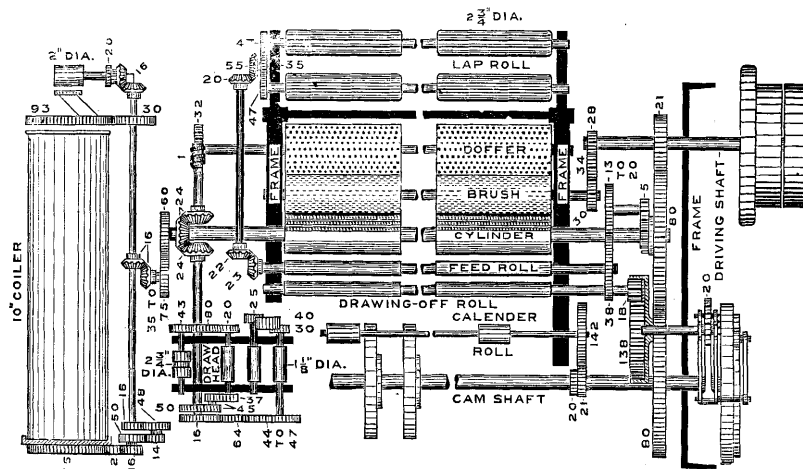

FIG. 134.

Calculations.—Draft: The total draft of a comb is distributed between eight different parts of the machine, the two principal drafts being between the feed roll and detaching, and between the rolls of the draw box. The other drafts are very small, being only a fraction over one, and are used for the purpose of keeping the lap and slivers taut in their passage through the machine.

The draft between the draft rolls is generally constant and is about 4. The draft between the feed roll and the detaching roll is generally about 5, but can be varied, the total draft of the machine varying between 20 and 30.

The total draft is the ratio between the surface speeds of the lap roll and the coiler roll of the coiler head.

The Draft Constant, with reference to diagram Fig. 134 is figured thus:

$$\frac{2 \times 16 \times 16 \times 60 \times 5 \times 38 \times 22 \times 55 \times 47}{2\frac{3}{4} \times 16 \times 16 \times 69 \times 1 \times * \times 23 \times 20 \times 35} = 424.434.$$

Draft Constant \div Gear = Draft.
 Draft Constant \div Draft = Gear.

Example: We use a 20 tooth change gear on the comber, what draft will it produce?

$$424.434 \div 20 = 21.22 \text{ draft.}$$

Example: We wish to produce a draft of 25 on the comber, what draft change gear will it require?

$$424.434 \div 25 = 16.97 = 17 \text{ gear.}$$

The actual draft using 17 gear equals:

$$424.434 \div 17 = 24.97 \text{ draft.}$$

The amount of draft is regulated by certain requirements, viz:

A light lap can be more effectually treated than a heavy one, because of the fact that it is able to sink deeper amongst the needles of the combs, which makes the action of the latter more searching and the combing action more uniform. When a heavier lap is used, the top fibres of the portion of lap under operation do not get combed as thoroughly as those below, because in this instance the needles do not fully penetrate the lap, for which reason the weight of the lap should not exceed that which allows the comb needles to properly penetrate the lap close to the nip.

Making use of a large draft in order to increase the amount of combing does not signify that such would in all cases be beneficial, since excessive combing will have a deteriorating effect upon the sliver produced. The most suitable length of lap to feed, which of course decides what is the best draft, depends not only upon the degree to which nep must be absent from the sliver after combing, but also upon the character of the cotton.

If the operation of combing is employed principally for the extraction of short fibres, a low draft and a heavy lap will secure all that is desired, whereas when combing has also to extract any impurities yet in the cotton, a more moderate feed and draft should be used.

A sign which indicates that combing is performed satisfactorily is the absence of any nep, entangled fibres or impurities in the combed sliver. Whenever it is possible to increase the weight of the films at the

combing heads without causing a deterioration in their appearance, and without increasing the percentage of waste extracted, it is advisable to do so. When the draft becomes lower than 26, or the feed more than 0.25 inches for each nip, we may consider that about the extreme limits have been reached.

The production of a comber, depends upon several considerations, viz., the working width of each head, the number of nips of the machine per minute, the weight per yard of the combed sliver, and the time the machine is operated. If the stock is neppy and the carding is defective, the production will naturally suffer, because of the extra work required of it.

The production of a comber is figured from the surface speed of the coiler roll, the time run, and the weight per yard of the delivered sliver. For example: What is the production of a comber for a day of 10 hours, allowing 5% loss for stoppages, etc. of the machine, the speed of the machine being 80 nips per minute, and the sliver weighing 50 grains per yard.

The surface speed of the coiler roll equals:

$$\frac{80 \times 60 \times 16 \times 16 \times 2'' \times 3.1416}{69 \times 16 \times 16 \times 36''} = 12.14 \text{ yards per minute.}$$

Then multiply yards per minute with time run and weight per yard, and divide product by 7000, the quotient being production expressed in pounds =

$$\frac{12.14 \times 570 \times 50}{7000} = 49.43 \text{ pounds per day.}$$

The production, when combing Sea Island cotton for yarns, ranging from 150's to 200's, should not exceed 200 pounds in 60 hours. The lap fed to the machine in this case should weigh between 180 and 210 grains per yard, care being taken to have enough body to the lap in order that the nippers may hold it firmly.

When combing Egyptian $1\frac{3}{8}$ inch staple for making yarns ranging from 60's to 90's, a production of 420 pounds in 60 hours should be obtained without deteriorating its quality. On Peelers, $1\frac{1}{4}$ inch staple a production of 325 pounds in 60 hours for spinning numbers from 50's to 70's is considered satisfactory, owing to the character of the stock, which is very neppy, and necessarily requires a lighter lap to be fed to the machine.

The production of a comber may also be figured from the weight in grains per yard of the lap fed, the number of nips per minute, the amount or length of lap delivered per nip by the feed roll, the number of heads in the machine, and the actual time the comber is run. This method for calculating is seldom used as it is not as accurate as the

preceding method, owing to the varying percentages of waste taken out of the cotton, but in order to show how to proceed with the calculation, the following rule is given:

Multiply together the weight per yard of lap, the number of nips per minute, length of lap delivered per nip, the number of laps fed to the machine and the time the comber is run, the product thus obtained being divided by the inches per yard (36) and the grains per pound (7000).

The answer includes both the amount of combed fibres delivered and the amount of waste extracted in the process, so that in order to obtain the actual number of pounds of combed fibres delivered, we have to deduct from the answer the percentage of waste made. This percentage of waste made is ascertained by means of an experiment on the comber, which is carried out by stopping the machine, cleaning away all waste at the back of the machine, breaking the waste off evenly and close to the doffer combs. The combed sliver which is delivered from the block rollers in front of the draw box, must be also broken off at that point, because of the fact that all of the good sliver made during the experiment has to be weighed afterwards. The comber is then run for about 30 or 40 nips, the more the better (as a good average is thus obtained) but not for too many, as the detection of variation in short lengths of lap is not so easily accomplished. Get all of the sliver produced during the run made and all of the waste made, weigh each separately, afterwards adding the two weights together, and dividing the sum into the weight of waste. Then multiply result by 100 and the answer will be the percentage of waste made.

Suppose, for example, that in the time run, 384 grains of good sliver and 96 grains of waste, including that taken from all the heads, are produced, then we would have $384 \text{ grains} + 96 \text{ grains} = 480 \text{ grains}$, and

$$96 \div 384 = 0.2, \text{ and}$$

$$0.2 \times 100 = 20 \text{ per cent waste made.}$$

In order to illustrate the rule given for production, we will use the following example:

What will be the production of a six head comber for a day of 10 hours, allowing 6% loss for stoppage, the comber making 80 nips per minute, the lap weighing 270 grains per yard, the feed roll delivering 0.24 inches per nip, and 20% waste being extracted?

$$\frac{270 \times 80 \times 0.24 \times 6 \times 564}{36 \times 7000} = 69.608 \text{ pounds fed per day.}$$

$$69.608 - 20\% = 55.687 \text{ pounds production per day.}$$

THE ALSATIAN COMBER.—The Alsatian Comber differs from the combers previously described, in that it is a single headed machine,

treating one lap of cotton. The principles of action of this comber are similar to those of the Heilmann comber as previously treated. The same preparatory machines (Sliver and Ribbon lap machines) as used for making a lap for the Heilmann comber are also necessary for this comber, the chief difference in the laps made, being that they are much heavier than those prepared for the Heilmann machine.

In order to explain the principles of action of this comber, diagrams Fig. 135 and 136 are given, being sketches showing the positions of the important parts of the comb during its two principal operations.

Keyed on shaft *A* are single arm *B* and double arm *C C'*, the latter carrying a shaft *C''*, both arms combined constituting the upper portion of the "carriage." *D* is the top nipper, being fixed on the arm *B*, while the arm *E* (as forms the bottom of the carriage) carrying the bottom nipper *F* is joined to the arm *C'* by hinge *G*. The top nipper *D* receives only one motion (oscillating motion), while the bottom nipper *F* receives two distinct motions, viz: an oscillating motion and a gripping motion. After this comes the combing operation of the circular comb and then an opening movement of the nipper *F*, in order to allow the detaching operation to take place.

The first mentioned movement is obtained by having the shaft *A* actuated by a double cam, which gives the "carriage" an oscillation through an angle of 28 degrees.

The bottom nipper *F* is held by tension rods *H* with springs *I*. In the combing position, indicated by the Fig. 135, the cotton coming from the feeding rollers *J J'*, and in turn passing a feeding carding roller *K*, is gripped between the two nippers *D* and *F* which present it to the circular comb *L* for the combing action. During this operation, the top comb *M* is of course out of working position, being situated above the top nipper *D*. When the last row of needles on the circular comb *L* has passed through the fibres, the shaft *A* of the carriage oscillates with the nippers *D* and *F* towards the pair of detaching rolls *N N'*. At a certain time during this oscillating motion of the carriage, the bottom nipper *F*, by means of a separate motion to be described later, ceases to press against the top nipper *D*, and thus begins the opening of the nippers, which is continued during the rest of the forward oscillation of the carriage. When the latter movement is finished (see Fig. 136) the combed head of the film lies on an endless leather apron *O* as passed around fluted roller *N*, or more correctly speaking, on the tails of the previously detached film, being pressed between fluted roller *N'* and the leather apron *O*. At the same time that the bottom nipper is released from its pressure against the top nipper, the top comb *M* is made to descend quickly into and through the film of cotton under operation.

Three movements in the machine now begin simultaneously:

(1) The detaching rolls *N N'* begin to revolve, grasping the front ends of the fibres of the film of cotton, pulling them through the needles of the top comb *M*.

(2) The feeding carding roller *K* feeds the lap (see dotted line in Figs. 135 and 136) slowly forward towards the detaching rolls *N N'*, the length fed being about $\frac{1}{4}$ of an inch.

(3) The top comb *M*, whose needles then engage the film or lap of cotton under operation, simultaneously also makes a forward motion

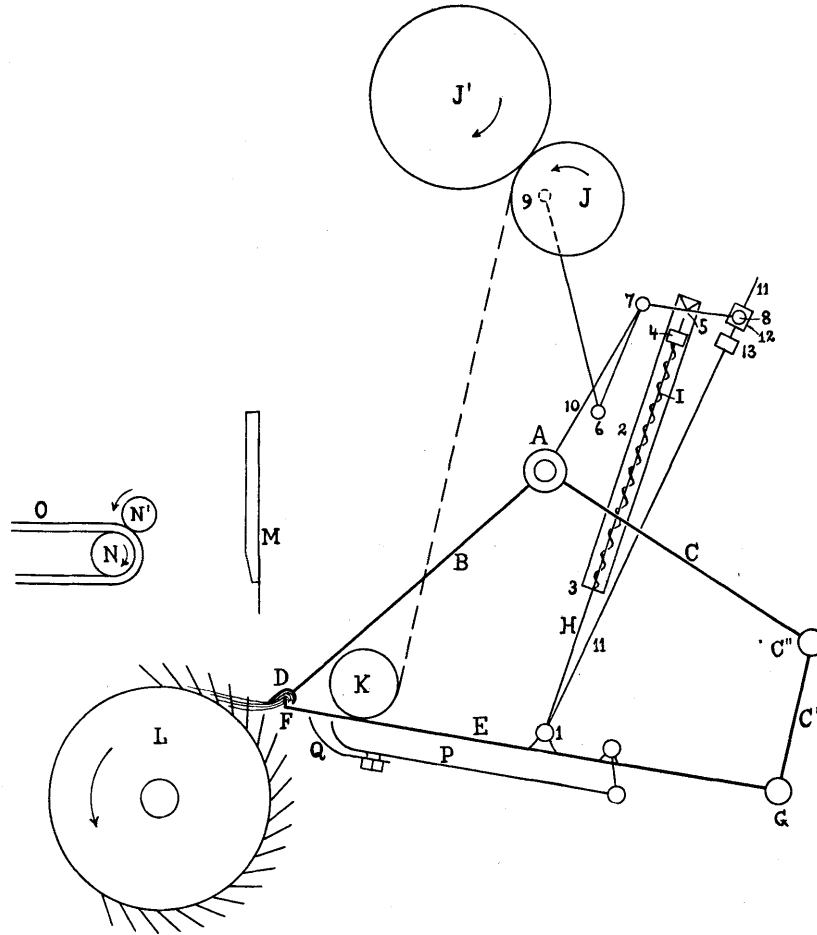

FIG. 135.

with the feeding of the lap previously referred to, the object of it being to avoid tangling of the fibres behind the needles; in other words, the top comb advances slowly with the film towards the detaching rolls *N N'*.

When the feeding of the lap has been sufficient, the top comb is as near as possible to the detaching rolls, but does not touch them. These

rolls then revolve a little more, in order to complete the detaching operation of the fibres, as gripped during the last feeding, from the lap.

The carriage then oscillates backwards and when it arrives at the point where, in the previous forward oscillation, the bottom nipper began to open, this latter begins to close, causing a pressure against the top

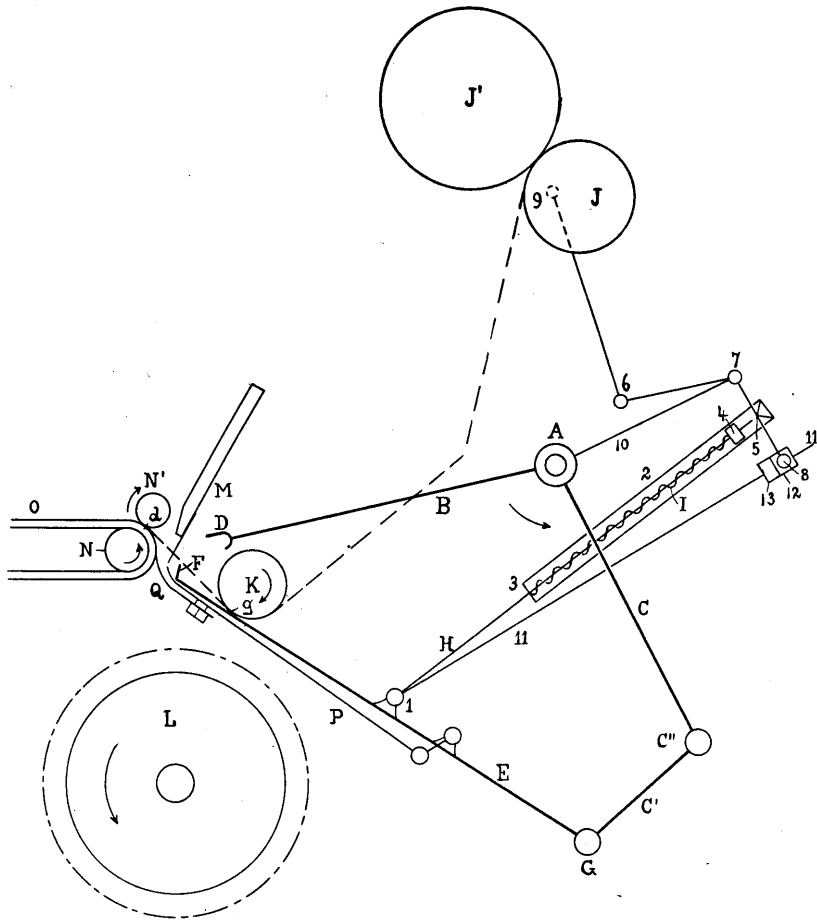

FIG. 136.

nipper, thus gripping the lap again. When this backward oscillation is completed, the carriage then is again in the position for holding the lap into the path of the needles of the circular comb *L*.

During the backward oscillation of the carriage, the detaching rolls *N N'* revolve slightly in the reverse direction from delivering, in

order to return a certain length of the film as is necessary for the next attaching operation. During this backward motion of the rolls $N N'$, the tail of the previously combed film is slightly pressed down against the feed apron O (by means of a rod to which a quick up and down motion is imparted) being placed in this position so that the head of the next combed portion of the film can be easily laid on the former, thus giving a perfect piecing. The feeding of the lap is done when the carriage is in its lowered position (Fig. 135) by means of a sufficient revolution of rollers J and J' .

The running of the comber can thus be divided into two principal actions, each having a subordinate operation:

(1) The combing of the head of the lap by the circular comb L ; to which is subordinate the feeding of the lap from its spool by the feed rolls J and J' .

(2) The detaching operation and the combing of the tails of the film by the top comb, and the feeding operation of the lap through the nippers D and F ; to which in turn again is subordinate the slight backward motion of the detaching rolls $N N'$.

Extraction of Noils and Impurities from the Lap.—The object of the comber is to comb, as perfectly as possible, the whole length of the fibres. Combing is done in two periods, the front end of the grasped fibres being combed by the needles of the circular comb, the other ends being drawn through the needles of the top comb. For instance, to comb cotton of $\frac{4}{10}$ inch staple, we comb about $\frac{6}{10}$ of an inch of the fibre with the circular comb, and the rest, about $\frac{8}{10}$ of an inch, with the top comb.

It must be mentioned here that the top comb cleans more thoroughly than the circular comb, although the latter has a greater number of rows of needles (22 to 24), while the top comb has only, as a rule, one row of needles, or in some cases two. The reason for the more thorough cleaning action of the top comb is the fact that the tail of the detached film is pulled from the thick lap which is somewhat compressed, the impurities thus remaining in the lap being unable to pass along with the fibres as detached from the lap, owing to the friction set up between said impurities and the fibres of the lap. This cleaning action to the detaching fibres by the lap increases with the thickness of the lap under operation, from the fact that the detaching fibres are then surrounded with a greater number of fibres in the lap, with which the detached fibres leave their impurities. On account of the cone shape of the needles of the circular comb (which is necessary to allow them to comb through the lap), the open space at the point of the needles is greater than at the base. The fibres passing through the comb at the base of the needles are of course more effectively cleaned than such as pass through at the point of the needles, because in this instance, some fibres are placed just in the middle of the space, and are thus not touched by the needles of that row.

The next row of needles would possibly exert a better combing action on such fibres, and so on for the succeeding rows of needles, so

that in order to have the heads of the fibres thoroughly cleaned, it is essential to use a large number of rows of needles on the circular comb, and in order to clean the tails of the fibres, a thick lap to help the work of the top comb should be used.

To meet these conditions, 22 to 24 rows of needles are mounted on the circular comb, and the machine is fed with a lap weighing from 1200 to 2000 grains per yard, according to the grade of cotton used. Referring to the action of the circular comb before the parts have taken the position shown in Fig. 137 (which is a special diagram given to illustrate the production of noil by the top comb), this comb will take away all the fibres not grasped by the nippers D and F , and which will have a length less than a . The fibres combed by the circular comb are not well cleaned over their entire length, since the part close to the nippers is only combed by the points of the needles, and as mentioned before, on account of the cone shaped needles, they will not be so well cleaned; thus we may say that the cleanliness of the film as combed by the circular comb, decreases from the head to the gripping point of the nippers. Referring to Fig. 137, the detaching rolls $N N'$ grip the combed fibres, and pull them through the top comb M . The length of the shortest fibres contained in the detached film may be determined in the following manner:

The rolls $N N'$ perform the detaching operation while the lap is fed forward, thus they can grasp at the end of the feeding operation, that is, a little before said rolls $N N'$ stop, fibres which did not at first reach the gripping point d . These fibres were at least long enough to be gripped by the nippers D and F before the detaching operation, because if they had been shorter, they would not have been gripped by the nippers and thus would have been taken away by the circular comb, and put into the noils.

If during detaching the lap is fed of the length b forward, the detaching rolls $N N'$ can grasp at the last moment fibres of a length $a-b$, because of the length b fed. The combed film then contains only fibres of a length $a-b$, or longer. As the cleanliness of the fibres, combed by the circular comb, decreases from the head of the film to the gripping point of the nippers, it is clear that the top comb must descend as near as possible to the detaching rolls, because there will be a greater part of the film not sufficiently cleaned, behind the top comb, and which in turn will have to pass through the needles of the latter in order to get properly cleaned. If the top comb falls only a slight distance backwards more than is necessary, all the impurities which are included in this distance will go in the film and consequently injure it. Thus the degree of cleanliness of the film will increase with the distance between the nippers and the line f where the top comb descends into the film.

This distance e to f can also be represented by the distances $a-(b+c)$. In this formula, a represents the distance between the gripping point of the nippers and detaching rolls, and is about $\frac{3}{4}$ of an inch; b represents the length of the feeding, usually about $\frac{1}{4}$ of an inch, and also

the distance moved by the top comb M during the feeding (to avoid tangling behind its needles); c is the lost space on account of the circular shape of the rolls $N N'$, which does not allow the top comb to get any nearer to the gripping point d . To decrease this space c as much as possible, the rolls are made with the best material, so as to allow of minimum diameters, the bottom roll being about 1 inch while the top roll is about $\frac{3}{4}$ inch. The rolls receive a rather heavy pressure, and it is not

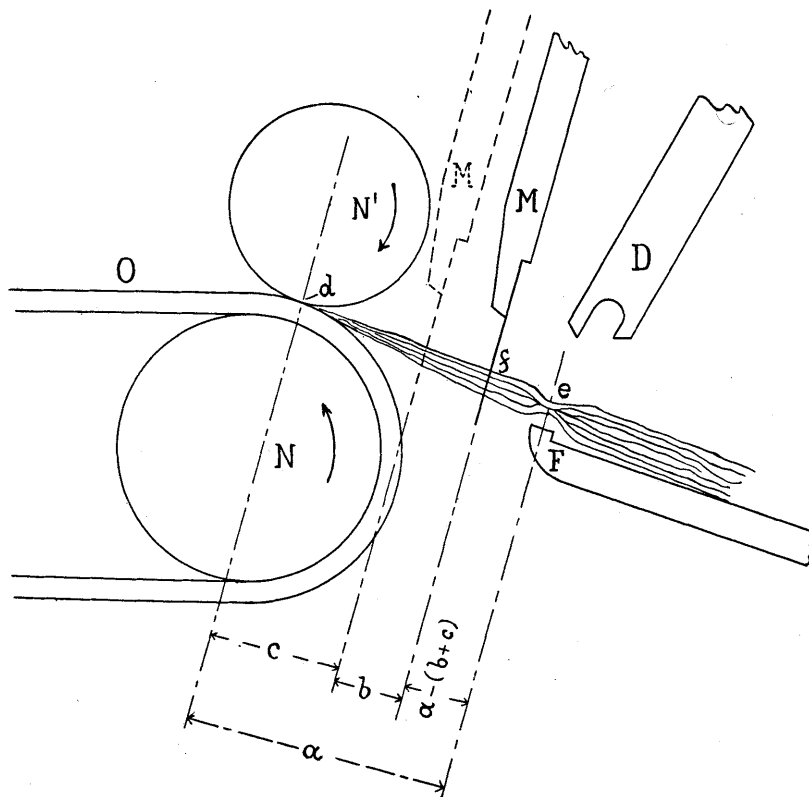

FIG. 137.

advisable to reduce their diameters too much. However, a solution of the problem, which allows a small diameter, has been found by having the rolls fluted with big helicoidal grooves, that is, the flutes and grooves are not parallel with the rolls, but are placed on them spirally. The gripping of the rolls thus takes place successively from one end of the rolls to the other, and the flutes do not grip the combed film all at once

over the whole width of the working space of the roll. This allows a good reduction of the weight on the fluted rollers, and a lessening of their diameters. The greater the distance e to $f = a - (b + c)$ is, the cleaner will be the combed fibres, or we may say that the cleanliness will increase when a increases, and also increase when b and c decrease. When required to produce more combed sliver by increasing the feeding b , but without affecting the cleanliness of the product, it is necessary to increase a in a certain way, and to maintain $a - (b + c)$ at its same value.

It will be seen that if the feeding is augmented without changing the distance a , the comber will produce less noils, and hence the cleanliness of the fibres will decrease when the other parts remain in their same positions.

The following rule is the result, confirmed by practice:

A decrease in the distance, a , of $\frac{1}{100}$ of an inch decreases the percentage of noils the same amount that an increase of feeding of $\frac{1}{100}$ of an inch would. The best results, as to cleanliness of the fibres, are obtained by having the feeding as little as possible.

By reducing the feeding, production suffers, but to compensate for this loss, a very thick lap is used, as mentioned before. Of course, the thick lap can only be used when it is possible to comb the fibres progressively with a large number of rows of needles on the circular comb, as used in connection with this comber (22 to 24), since a large number of rows of needles with large spaces between them (the first rows having big needles to be able to properly start combing the fibres, while the succeeding rows are made of gradually finer needles to properly continue the operation), will clean the fibres very effectively.

The following tables will show two systems of fitting up the needle bars of the circular and top combs.

TABLE No. 1. (Single row top comb.)

Rows of Needles.	Needles per Inch.	Number of Wire.	Length of Needles in Inches.	Combing portion of Needles in Inches.
1-2	10	18	$\frac{1}{2}$	0.28
3	$12\frac{1}{2}$	18	$\frac{1}{2}$	0.28
4-5	15	20	$\frac{1}{2}$	0.28
6	20	20	$\frac{1}{2}$	0.24
7-8	25	22	$\frac{1}{5}$	0.24
9	30	24	$\frac{1}{5}$	0.24
10-11	35	24	$\frac{1}{5}$	0.20
12-13	40	26	$\frac{1}{5}$	0.20
14-15	$47\frac{1}{2}$	27	$\frac{1}{5}$	0.16
16-17	55	27	$\frac{1}{5}$	0.16
18-19	$62\frac{1}{2}$	28	$\frac{1}{5}$	0.16
20-21-22	75	29	$\frac{1}{5}$	0.14
Top Comb.	$57\frac{1}{2}$	27	$\frac{1}{5}$	0.28

TABLE No. 2. (Double row top comb.)

Rows of Needles.	Needles per Inch.	Number of Wire.	Length of Needles in Inches.	Combing portion of Needles in Inches.
1-2	* 10	14 to 20	$\frac{1}{2}$	0.28
3	* $12\frac{1}{2}$	14 to 20	$\frac{1}{2}$	0.28
4-5	* 15	14 to 20	$\frac{1}{2}$	0.28
6	* 20	16 to 22	$\frac{1}{2}$	0.24
7-8	* 25	16 to 22	$\frac{1}{2}$	0.24
9	* 30	18 to 24	$\frac{7}{16}$	0.20
10-11	* 35	18 to 24	$\frac{7}{16}$	0.20
12-13	* 40	20 to 26	$\frac{7}{16}$	0.20
14-15	* $47\frac{1}{2}$	21 to 27	$\frac{7}{16}$	0.16
16-17	* 55	22 to 28	$\frac{7}{16}$	0.16
18-19	* $62\frac{1}{2}$	23 to 29	$\frac{7}{16}$	0.16
20-21-22	† 75	29	$\frac{7}{16}$	0.14
Top Comb.	* 24	22 to 28	$\frac{11}{16}$	0.28
	* 26	23 to 29	$\frac{11}{16}$	0.28

* = Flat Needles. † = Round Needles.

In the table No. 1, the round needles are referred to, however flat needles as given in table No. 2 are more frequently used, although they are more difficult to solder, but in turn last considerably longer.

To be able to fit up a large surface of the combing cylinder with rows of needles as required in the present comb, the fluted segment, as used in connection with previously described combers, is dispensed with, it being unnecessary in connection with the present comb, the detaching rolls *N N'* and the endless apron *O* in this case performing the attaching operation in conjunction with the oscillating motion of the carriage carrying the nippers.

On the forward oscillation of the carriage, as previously mentioned, the top comb comes into action. The lap, although thick, must be pierced through by the comb, so that no fibre can pass without being combed. There is little danger of taking the edges off of the needle points of the top comb by the latter falling too low, the comb falling at the beginning of the detaching operation right through the fibres, its points projecting slightly underneath said fibres, the comb during the detaching operation of the fibres going forward at the same rate as the feeding of the lap, the comb finally stopping very near the detaching rolls, but without touching them.

To prevent any possibility of the needles of the top comb from touching the endless apron *O*, a thin steel plate *Q*, as attached to a sheet iron piece *P*, comes between the apron and the needle points. This plate draws back after the detaching operation and during the combing operation by the circular comb, it then rests under the bottom nipper *F*. After the combing operation by the circular comb, this plate *P* moves

again forward and comes under the top comb, and during feeding the lap to rolls $N N'$ follows the movement of the top comb. If the top comb did not go quite through the lap, the latter could not be made so thick, because the thicker the lap is, the more the top fibres will press upon the bottom ones, and a large quantity of fibres would then be detached without being combed.

Fig. 138 is a sectional view showing more in detail the construction of the feed carding roller K and its action on the lap, top and bottom nippers D and F respectively, the sheet iron plate P and its thin steel plate Q , the combing of the lap by the circular comb L , the top comb M ,

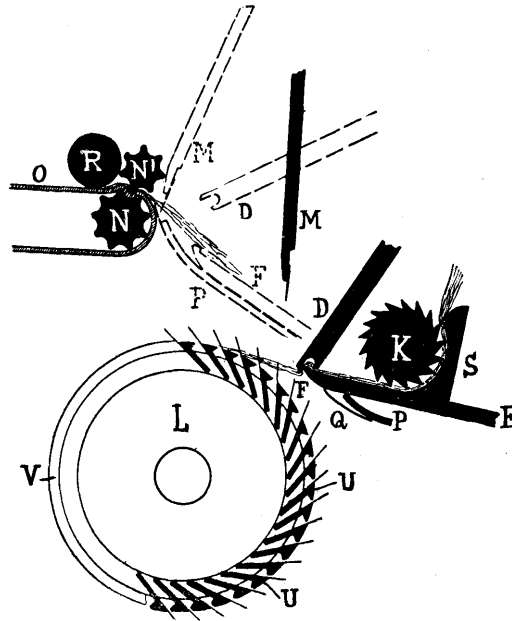

FIG. 138.

the detaching rolls $N N'$, the endless apron O , a pressure roller R to work in connection with the detaching mechanism. Top and bottom nippers as well as top comb are shown in their two extreme positions, in full black and in dotted outlines respectively.

The carriage is one of the most important parts of this comber, since it carries all of the feeding motions, the top comb as well as the sheet iron piece P , as situated under the nippers of the carriage. The method of oscillating the carriage, in order that the combed fibres may be attached to the previously combed fibres, is shown in Fig. 139, where the eccentric shaft 1, carrying the two eccentrics 2 and 3, is driven from

the main shaft of the machine through gears at 95 revolutions per minute, which corresponds to the number of nips per minute of the comber. The shaft *A*, which is the pivot for the carriage to turn on, is also the centre for the three lever casting 4, 5, 6, which is fixed against a flange 7 by means of a bolt, and the centre for the lever 8 which is also loose on the shaft. The lever 4 of the three lever casting carries at its

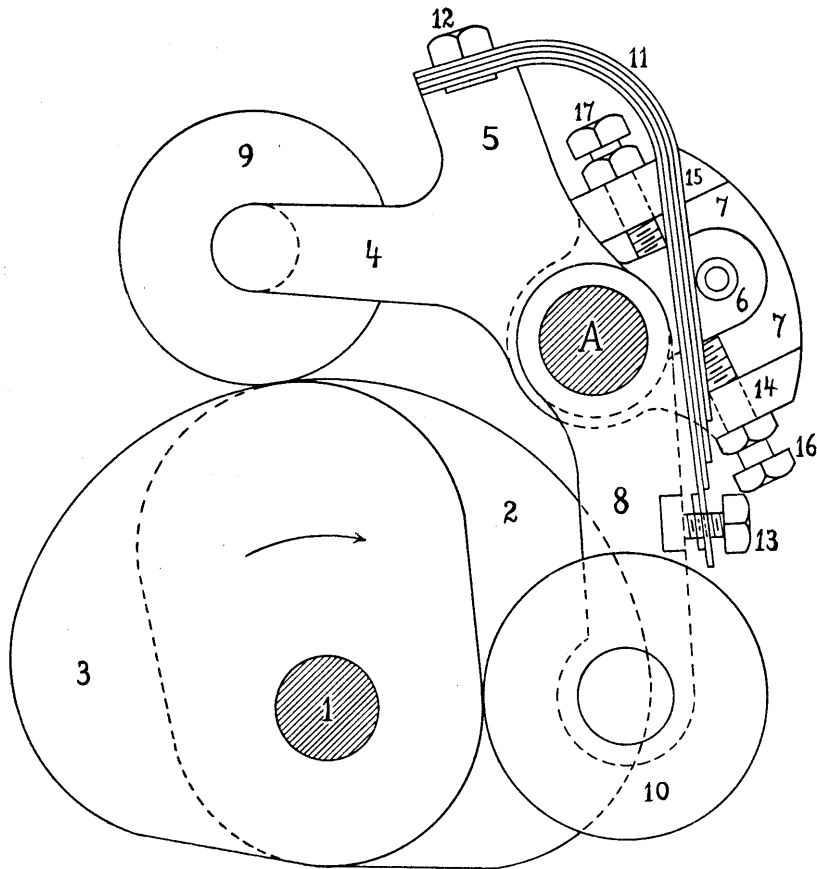

FIG. 139.

end a roller 9 which rolls on the eccentric 2, while lever 8 carries a roller 10 at its end, which in turn rolls on the eccentric 3, both rollers being kept in contact with their respective eccentrics by means of a spring 11, secured to lever 5 by a nut 12, and having its other end press against the lever 8 through a screw 13 which tends to stretch said spring. The two rollers 9 and 10 are always on opposite diameters of the eccentrics 2 and

3, as shown in the illustration, that is, 9 always rolls on the large diameter of 2, while 10 rolls on the small diameter of 3, and vice versa. In case the two levers 4 and 8 were made in one casting, the eccentrics would have to be set very accurately in order to prevent said levers from breaking, or causing too much lost motion and consequently one of the rollers leaves its eccentric, the proper motions to the carriage and feeding motions thus being destroyed.

By using the spring 11, the irregularities from the eccentrics can be taken up without hindering the motion of the carriage, the only thing necessary being that one of the eccentrics shall be perfectly true. Owing to the large number of oscillations per minute of the carriage, it is very important to have the pieces strong and set accurately. As was mentioned, the casting 4, 5, 6, which is loose on the shaft *A* is fixed to the flange 7, said flange being keyed to the shaft *A*. The flange carries two wings 14 and 15 provided with set screws 16 and 17 respectively and which press against the lever 6, the flange 7 thus being actuated by said lever 6 and the shaft *A* in turn given a corresponding movement. The set screws 16 and 17 are used for setting the carriage in its proper working position.

The method of actuating the bottom nipper *F* for gripping the lap, in connection with the top nipper *D*, is shown in Figs. 135 and 136. The top nipper is made concave at the gripping point (see also Fig. 138). The front point of the top nipper presses the lap as extending past the nipping point, into the circular comb *L*, and at the same time helps to grip the cotton by having the lower nipper press the cotton up into the concave portion of the top nipper. It will thus be seen that the use of leather in connection with these nippers is dispensed with, but at the same time a firm and satisfactory grip on the cotton is obtained.

As mentioned previously, the arm *B* carrying the top nipper is fast to the carriage, while the arm *E* carrying the lower nipper is hinged at *G*, and consequently when the nippers have to be opened to allow the cotton to pass through for combing, the bottom arm *E* is the one to be operated. On this bottom arm *E* are fixed brackets for holding the shaft 1, on which are secured two spring rods *H* (only one shown in illustration) one on each side of each fork link 2 which is Ω shaped, the rods passing through the bottoms 3 of the fork links respectively. The springs *I* on the rods *H* are strongly compressed by the nuts 4, the other ends of the springs pressing against the bottoms 3. The forked links 2 are pivoted at their upper ends in a groove 5 of the rigid lever 6, 7, 8, this lever being connected at 6 to the connecting rod 9-6, which is suspended from a stationary point 9. The shaft 7 is supported by an arm 10, which is rigidly connected with the levers *B C* and oscillates with the carriage. The springs *I* in pressing on the parts 3 of the fork links 2, act to keep said forks steady in the groove 5 of the lever 6, 7, 8. As this lever is held by the connecting rod 9-6 suspended from the point 9, the pressure of the springs *I* act from bottom to top on the nuts 4 and transmits this pressure to the rods *H*, which in turn transmit it to the

bottom arm *E* by its connection with it, and thus the bottom nipper *F* on the arm *E* is pressed up into the top nipper *D*, and the cotton gripped between them.

The movement for opening the nippers, which takes place when the carriage oscillates towards the detaching rolls *N N'*, is made through the rod 11 which is placed about in the centre of the length of the shaft 1. The other end of the rod passes through the stud 12 situated on the end of the lever 7-8, so that it may turn, the rod 11 having a setting nut 13 situated a slight distance below the turning stud 12, in order to allow a little play between them when the nippers are closed. When the carriage oscillates towards the detaching rolls *N N'*, the parts take up the positions shown in Fig. 136. It will be seen that as 12 is situated farther from 7 than the pivot 5, it will pass through a larger space, and the play between the nut 13 and the stud 12 will soon disappear, and 12 will then produce a pressure on the nut 13, and through the rod 11 give the shaft 1 a pressure from top to bottom, which in turn causes the lower arm *E* to move downward and disengage the lower nipper *F* from the top nipper *D*, at the same time putting a new compression into the springs *I*. This is necessary in order to prevent the nippers from opening while detaching. When the carriage oscillates backwards, the lower nipper *F* comes again towards the top nipper *D*, being the same position that the lower nipper *F* occupied when it left the top nipper *D* during the forward oscillation of the carriage. The play between the lever 8 and nut 13 gradually becomes larger, the lever rod 11 having become inactive as soon as the slightest space appears between them, and the pressure of the springs *I* is again brought into use to keep the nippers closed. This pressure can be increased or decreased by the nuts 4 on the rods *H*, while the opening of the nippers during the detaching movement is regulated by the nuts 13, that is, by screwing the latter down the opening will be decreased and the nippers will open later, whereas by screwing them up the opening of the nippers will be wider and earlier than in the first case.

The setting of the opening of the nippers is very important for good working. The lap is fed by the toothed card roller *K* which is mounted in bearings held by spring pressure. A trough *S*, situated behind the roller *K*, having spring pressure also, presses the lap against said card roller. In order that the nippers may have the correct opening, the lap must be able to go in a straight line from *g*, where it leaves the card roller, to the gripping point *d* of the detaching rolls *N N'*. This is necessary in order to prevent the fibres from touching the point of the bottom nipper *F*, which otherwise would render the detaching irregular, difficult and would increase the percentage of noils made. The nuts 13 on the rods 11 must therefore be set to give the proper opening. Of course, the nippers must not be opened too far or the bottom nipper *F* go too low down, as in this instance the sliver would not be carried forward for proper piecing at the detaching rolls, and also it is possible that the springs holding the sheet iron piece, under the bottom nipper, would come in contact with the needles of the circular comb and thus

injure them. To have a good cleaning of the heads of the fibres, it is necessary to set the top nipper D very near the point of the needles of the circular comb. This distance must be about $\frac{3}{100}$ of an inch and is set by means of a suitable screw, after unscrewing a bolt which secures D to B . In order to press the heads of the fibres into the needles of the circular comb, the top nipper is fitted with a sinking brush (not shown) which should be near the needles but not touch them. Without this brush the top fibres would lift themselves up and consequently would not be combed by the circular comb. A proper setting of this brush increases the cleanliness of the fibres, but when it sinks too deeply into the fibres so that it touches the needles, the percentage of noils is considerably increased.

The circular comb L is built very strongly on account of the hard work which it has to do, making 190 revolutions per minute or two revolutions for every detaching operation. The needles of the circular comb are soldered on iron bars U which are driven into grooves of the comb cylinder, each of these bars being secured by three screws. The comb cylinder carries 3 discs, to which the iron bars, as carrying the needles, are fixed, the remainder of the cylinder being hollow to avoid a big weight. By taking off an outside plate V situated opposite to the needles, it is then easy to unscrew the bars successively.

As was previously mentioned, the combed fibres are attached to the previously combed fibres which have been returned a short distance by the attaching motion, in order to make a proper piecing, the fibres which are returned being kept low, by a pulling down motion, and also kept against the endless apron O . As the backward delivery of the fibres and the detaching operation have the same parts for these operations, they will be explained before talking of the top comb and feeding motions, which come between the first mentioned operations in the cycle of combing. The top detaching roll N' has a diameter about $\frac{8}{16}$ of an inch and is deeply fluted. The bottom detaching roll N is about one inch in diameter, and carries the endless apron O , said roll being also deeply fluted, as clearly shown in connection with Fig. 138.

The object in having these rolls grooved is to produce a firm grip on the fibres with a diminished pressure on the top roll, since a heavy pressure on the roll would spoil the leather apron O , as the latter has to travel forward and backward for the attaching and detaching motions, and if the two motions were made with a heavy weight on the top roll, the leather would be pressed during the backward motion, a feature unnecessary, as there is then no gripping of the fibres required as is the case in the attaching on the forward movement. For this reason the machine is provided with a motion for lifting the pressure off of the top roll during the backward motion, which motion consists principally in a revolving cam actuating a lever which raises and lowers the weight at the proper time.

The rolls are actuated for the attaching motion by means of an eccentric which actuates a lever connected to an arm just above its

pivot, said arm carrying at its other end a toothed segment. This segment drives suitable pinions, and through a ratchet and pawl arrangement, when the toothed segment is driven by the eccentric and levers, gives a forward rotation to the endless leather apron *O*. As the segment comes back, it drives a pinion and the leather apron is rotated in the opposite direction, which motion then returns a short length of the combed fibres for the next piecing.

The detaching operation must take place, that is, the rolls must begin revolving, when the carriage has still a short distance to go forward, because the feeding takes place at the same time as the detaching, and a great number of fibres are consequently carried towards the gripping point of the detaching rolls. All of the fibres thus fed at the last moment, and whose tail ends have gone further than the gripping point of the nippers, but not quite long enough to be tightly caught by the detaching rolls at their front ends, will very likely be taken away by the circular comb at the next combing operation and carried into the noils. In order to prevent this waste, it is necessary to make the detaching rolls revolve a little after the feeding has stopped, so that such fibres will be well grasped by the detaching rolls. However it is not a good practice to exaggerate this movement, because in that case it would be necessary to increase the backward motion of the rolls, which would tend to tear the leather apron *O*. The detaching is regulated by the eccentric previously referred to, and which may be set in any position desired.

The motion for pulling the tails of the combed film down on the endless apron *O* consists essentially in a blunt blade *T*, held by an arm on each end, and situated just in front of the detaching rolls, being connected through levers to a revolving cam from which it receives an upward and downward motion. The eccentric is shaped so that the blade goes down and remains stationary during detaching, and as soon as the carriage oscillates backward, ascends quickly so as to help in pulling the tails of the fibres out of the top comb. The blade may be set so that it will clear the leather apron, or it may be set lower, as the case demands. The two extreme positions of the blade are shown in connection with Fig. 140, being indicated by *T* and *T'* respectively.

The distance between the detaching rolls and the nippers, when the carriage oscillates to the rolls, is of great importance, as the cleanliness of the fibres and the per cent of noil depends considerably upon this setting. The setting is made by placing the detaching rolls up to the nippers and using the proper gauge between them. When set properly, the bracket carrying the bearings of the detaching rolls is bolted again to the frame of the machine. This bracket on the other end carries a pair of delivery rolls situated in front of the detaching rolls at the turning point of the endless apron, and also a roll for keeping the endless apron tight, but which may be released in case of a long stop of the machine.

From the delivery rolls just referred to, the combed film is passed through the usual trumpet and condensed into a sliver. After emerging

from the trumpet, the sliver is compressed by passing between a pair of calender rolls before entering the sliver can, in order to make the fibres in the sliver adhere more to each other and thus produce a stronger sliver.

The mechanism for actuating the top comb and feed carding roller is shown by means of Fig. 140, in which the parts are in the positions when these two motions are out of action, that is, during the combing of the lap by the circular comb. During the detaching operation, the top comb *M* is subjected to three different movements, viz:

(1) Forward and backward motion with the carriage, (2) Descending motion to penetrate into the combed film, and (3) Following the feeding motion of the lap during detaching.

The first of these motions is made through the shaft *A* as follows: The top comb *M* is fixed on the two sides to the arms 1 and can be set parallel to the detaching rolls by changing the positions of the arms 1 in the slot after unscrewing the bolt 2. The arms 1 are fixed to the double arm 3, 4, which is centered at *C''*. *C''* oscillates with the carriage, and thus the top comb *M* receives the same motion. The top comb is also joined to the shaft 6 through two connecting rods 7, each being joined separately to an arm 8. As these arms 8 are keyed on the shaft 6, they go with the motion of the top comb. The springs 9 help to bring the top comb down. The lever 10 has the same oscillations as the carriage, as it is all one piece with the arm 8 in Fig. 139. The lever 10, Fig. 140, is connected to the lever 11, the other end of which is connected to the lever 12 which is loose on the shaft 6. The arm 13 is keyed on shaft 6 and contains a screw 14 which rests on the top side of the lever 15, loose on the shaft 6. This shaft 6 thus carries two keyed arms 8 and 13, and two loose ones 12 and 15. On the outside of 15 is fixed a little stop 16, and centered on the pivot 17 on the lever 12, is the angle catch 18, 19, whose stop 20 presses against the piece 16, forced by the spring 21. These springs are screwed on the lever 15 and press against the arm 18 of the catch 18, 19. All of the parts are in the positions shown when the nippers are shut and the carriage is in its lowest position. If the carriage now oscillates towards the detaching rolls, the positions of the parts change in the following way: Through the levers 1 and 3 having a centre at *C''*, the top comb *M* oscillates forward and slightly upward. The crank 10 is raised and hence lifts the levers 11, 12, also the pivot 17, and in turn the lever 18, 19, with its stop 20 which comes under the stop 16 and lifts the lever 15, which in turn transmits this motion to arm 13 through the screw 14, and thus to the shaft 6, which in turn lifts the top comb *M* slightly through the levers 12 and 7.

The descending motion of the top comb now takes place, but the fall must not occur before the fibres are gripped by the detaching rolls and laid on the endless leather apron, or else it would push the heads of the fibres down and prevent them from being attached. If the top comb falls too late, or when the detaching operation is already begun, the tails of the fibres are not sufficiently cleaned. The fall of the top comb must

thus take place when the fibres have just been grasped by the detaching rolls, and which is produced by loosening the catch 20. Situated above the lever 18, when the detaching oscillation has been made, is the stud 22,

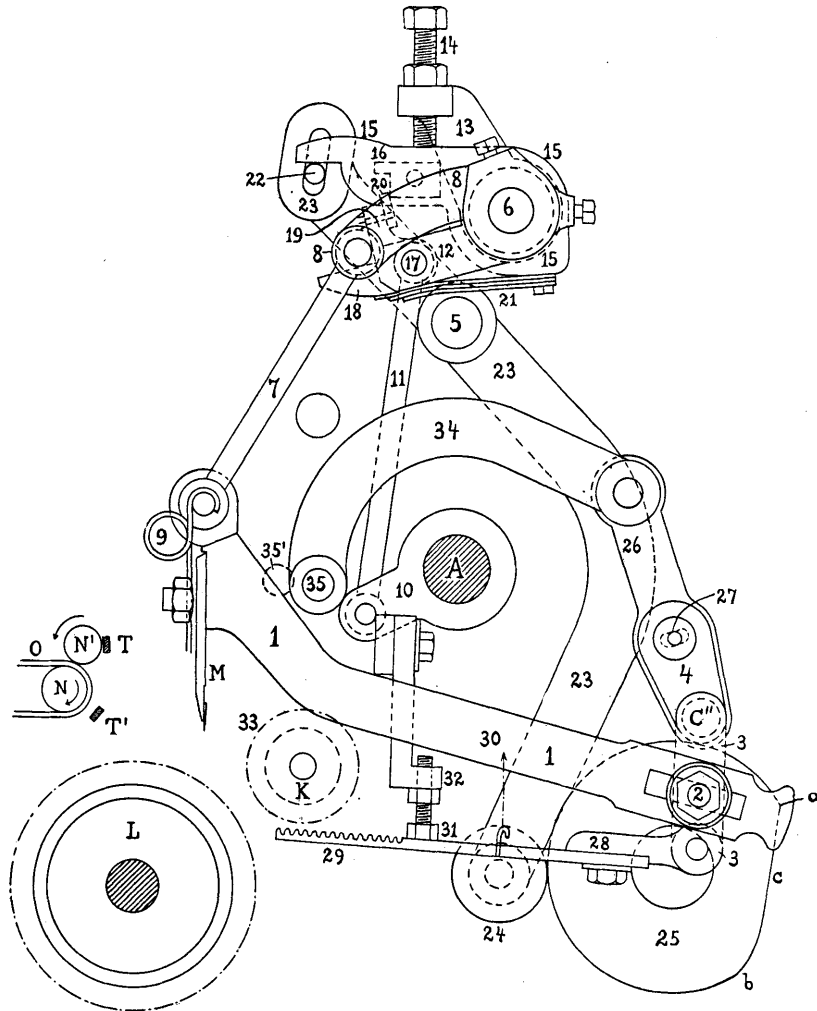

FIG. 140.

fixed in a slot of the lever 23, the bottom end of said lever carrying a roller 24 which is pressed against the eccentric 25, which is circular except in the cut part *a-b*. As soon as the point *a* of 25 comes in contact with 24, the stud 22 goes down, pressing on 18, and hence releases 20. Under

the action of the springs 9, the top comb now falls quickly until the under part of the lever 15 has come on the top part of the lever 12, which is maintained in that position by the pieces 11 and 10. The setting of the top comb for the correct height is made through the screw 14, which by tightening causes the comb to go lower down. Immediately after the loosening of the stop 20 and the fall of 16, the stud 22 ascends again when the roller 24 rolls on the part *c-b* of the cam 25, and remains stationary until the next fall of the top comb. As this fall must begin with the detaching operation, the only way to set the parts in proper timing is to turn the machine with the fly wheel until the detaching rolls are seen to begin revolving, then place the eccentric 25 in such a position, that the point *a* begins to give the fall to the comb. A change of the position of the comb in its slot would cause the comb to fall sooner or later, according to the direction in which it was moved.

Only the eccentric must give the fall to the top comb. The setting of the top comb towards the detaching rolls is made through the levers 4 and 26. If the comb is not in a good position, open screw 27 and alter the arm 4 until the proper position, parallel to the detaching rolls, is obtained. The same lever 3 which acts on the top comb to move it forward, also drives the feeding card roller *K* through proper connections. The joint 28 fixed to lever 3 carries the feeding rack 29. The spring 30 pulls the rack up against the set screw 31 of the stop 32 fixed to the carriage. During the combing operation, this screw 31 holds the rack 29 out of gear of the card roller gear 33. When the carriage is in the detaching position, the head of the screw 31 has left the rack 29, which then gears with 33 situated on the same shaft with the feeding card roller *K*.

The double arm 3, 26, is jointed to a lever by the curved arm 34 at 35, the upper end of said lever having a projecting rod which turns a ratchet wheel on the feed roller *J* when the carriage is in its lowest position with the nippers closed and gripping the cotton to be combed by the circular comb. The lower end of the lever carries a roller which is pressed against a cam on the same shaft with the cam 25. After the fall of the top comb, the cam causes the lever to move to the right, and thus put the projection at the top end in position to engage the ratchet on the feed roll *J* at the next oscillation of the lever to the left when the carriage is in its lowest position, as previously mentioned. At the same time of the oscillation of the lever to the right, the arm 3, through its connection with the lever, moves the top comb forward, and through the rack 29 turns the feeding carding roller *K*. These movements are stopped when the cam roller comes on the circular part of the cam, but the detaching rolls must revolve a fraction of a turn more in order to take any fibres which may have passed the nipping point of the nippers. The arrangement of the levers and roller controlling the feed card roller *K* allows its feeding to be changed without altering the setting of the top comb to the detaching rolls. The backward oscillation of the carriage, again alters the position of the top comb, and prepares it for the next fall

on a forward oscillation of carriage. The descending mechanism has taken after this fall such a position that the stop 20 has moved to the left and its right surface rests against the stop 16. Now the shaft *A* drives 10, 11 and 12 down, and the stop 20 is also taken with the arm 19 centered on 12. However at the same time the centre *C''* oscillates backwardly with the levers 3 and 1 and the top comb *M*, so that the shaft 6 will turn a little to the left, followed by the lever 13 with the screw 14 which presses against 15. The projection on 15 then comes on the stud 22, which in turn holds the shaft 6 steady, while the lever 12 continues going down with the catch 18, 19 which carries the stop 20, so that said stop 20 then slides easily under 16, and is again ready to support the lever 15 carrying the stop 16, and the lever 13 carrying the screw 14, until the next falling operation of the top comb takes place.

The sheet iron piece *P* under the lower nipper *F*, shown in Figs. 135 and 136, has for its object to hold the fibres, while the top comb descends into them and compels the fibres to go through its needles and not underneath them. The thin steel blade *Q* fixed under the sheet iron piece, under the nipper, is used to protect the leather feed apron *O* (as previously mentioned) from the needles, if for instance, the top comb was set too low, and in which case, the needles would come in contact with the blades instead of sticking into the leather. In order that during the feeding and the detaching operations, the fibres should be forced to pass through the needles of the top comb, the sheet iron piece *P* must go forward with the feeding and top comb movements, in order to be always at the same distance, i. e., $\frac{1}{16}$ inch from the points of the needles. To obtain this movement, the sheet iron is connected through levers to the operating parts of the feeding and top comb mechanisms. On the backward oscillation of the carriage, the sheet iron piece *P* comes away from under the lower nipper, which is necessary in order to allow the needles of the circular comb *L* to come close to the nipper for the next combing operation.

The cleaning off of the noils from the circular comb is done by means of a circular brush, revolving in contact with the needles of the circular comb, thus constantly cleaning them. The noils are stripped from the brush by having a doffer, which has its surface covered with card clothing, revolve in contact with said brush. The noils are then stripped from the doffer by means of a comb, in the form of a fleece, and may be wound on a roll by a suitable mechanism or dropped in any suitable receptacle. The connection between brush and doffer is constant and not influenced by any change of position of brush required to properly clean the comb.

The coiler arrangement for the combed sliver is driven from the driving shaft of the machine through a chain to a 26 tooth gear which is on the same stud with an 18 bevel gear, and this gear in turn drives a 24 bevel on the same stud with a 26 gear. This 26 gear through an intermediate, drives a 71 gear and a 73 mangle wheel. This mangle wheel has also 56 inside teeth which gear with the pinion of 34 teeth cast with the

plate wheel forming the base of the coiler. The shaft of the 34 pinion turns in a hole drilled in the 71 tooth gear out of the centre of its axis. As the 26 tooth pinion drives the 73 and 71 gears at the same time through an intermediate gear, these two gears consequently revolve separately and at different speeds, during which revolutions the 71 tooth gear drives the plate wheel round its own centre, due to the shaft being fitted into it. The 73 gear drives the plate wheel around its own centre through the mangle and other gears, and hence two movements for the plate wheel base of the coiler are obtained, i. e., a movement of the plate wheel round its own centre, and a planetary movement round the centre of the 71 tooth gear. This is necessary, because the sliver falls directly from the delivery rolls into the coiler, without passing through a revolving trumpet with sloping hole, as in the case with ordinary coilers.

THE MONFORTS' COMBER.—This comber is also known as the new German Comber and is built in this country by the Mason Machine Works. While for high counts the Heilmann Comber is recommended, the Monforts Comber certainly possesses advantages for medium and lower counts, chiefly amongst which are found a saving in cost of labor, floor space occupied by machine, as well as power required to operate it.

Fig. 141 is a cross sectional view of as much of this comber as is necessary to illustrate the operation of combing. Figs. 142, 143, 144, 145 and 146 are detail illustrations to show the positions assumed at the various stages of the combing operation by the detaching rolls, carrying-forward rolls, and the receiving and drawing rolls.

With reference to Fig. 141, the lap *A* as is made on the usual Sliver and Ribbon Lap Machines, similar to those in use with the "Heilmann" system of combing except that the laps are of a slightly greater width and slightly increased in weight per yard, is placed upon and unwound by the motion of the fluted wooden lap rolls *B*, which are given a continuous and uniform speed, as compared with the intermittent motion given to the similar rolls by the feed mechanism of the Heilmann Comber. The lap, as fast as it is unwound, is fed down the guide plate *C* into the bite of the metallic top and bottom rolls *D* and *E*. This pair of rolls, which constitutes the detaching device of the machine, serve to detach the tuft about to be combed from the body of the fleece, or lap, and operate as follows:

By suitable mechanism, the rolls *D* and *E* are rotated in a forward direction until a certain length of lap (which is determined by the length of staple to be combed) has been fed in. When this has been accomplished, the rear pair of rolls *D* are given a backward motion, while the rolls *E* still continue to revolve in a forward direction. The body of the lap between the rolls *D* is thereby drawn back or detached from the tuft between the rolls *E*.

The tuft of fibres is now carried forward by the continued revolution of the rolls *E* and thrust between the jaws of the rear nippers *F*, which are opened to receive it. At this instant, the front detaching roll *E* ceases its revolution, and the upper jaw of the nipper mechanism *F* descends

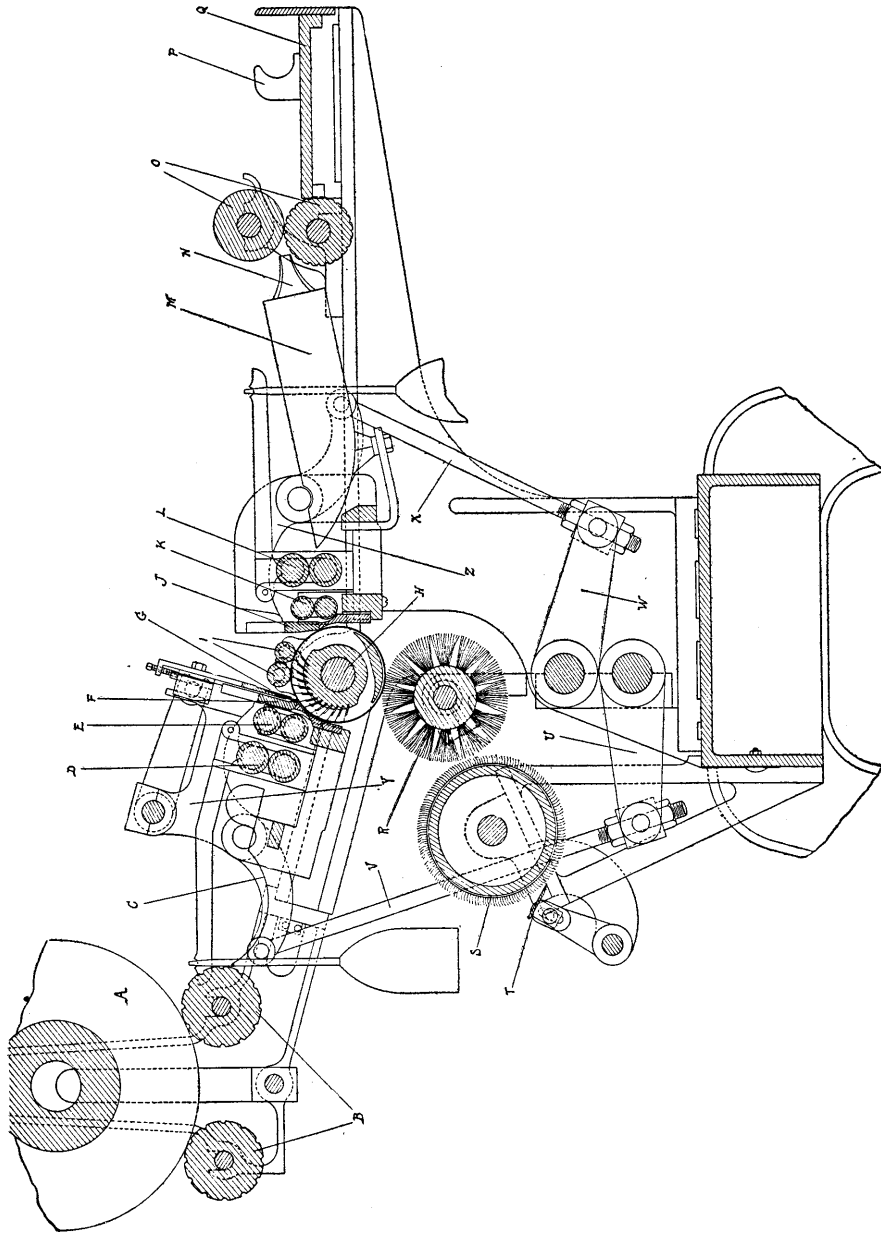

and firmly holds the tuft to be combed between its jaws. Working in conjunction with, but independent of the nipper mechanism, is the depressing brush *G*, the object of which is to depress the protruding ends of the tuft about to be combed, so that they will be directly in the path of the rows of combing needles mounted on the combing cylinder *H*.

After the needles have performed the operation of combing out the short fibres, the continued revolution of the combing cylinder brings into position that portion of itself which has no needles, and may be termed the carrying-forward portion. The instant that this carrying-forward portion passes under the ends of the already combed fibres, the upper jaw of the rear nipper *F* raises or opens, and, at the same time, a pair of bearing rolls *I*, which have heretofore been kept raised out of the way of the combing needles by an eccentric motion, are allowed to lower, until they rest upon the ends of the combed tuft, when, by a revolving motion given them by contact with the fluted portion of the combing cylinder *H*, they carry forward the tuft, and convey it between a pair of nippers *J*, which are now open and are situated in front of the paths of the combing needles and fluted section of the combing cylinder *H*, and onward to a pair of receiving rolls marked *K*. The rotation of the rolls *K* moves the tuft forward until the uncombed portion remains within reach of the combing needles or the combing cylinder *H*. When this has been accomplished, the receiving rolls *K* are stopped, and the upper jaw of the front nipper *J* descends and firmly holds the tuft, while the combing needles comb out the short staple and noil left in the rear or uncombed ends of the tuft.

In this way it will be seen that the combing of both ends of the fibre is performed in the same manner, and with the same needles, without the introduction of the top comb, which in all other machines is allowed to drop in the midst of the tuft, and the fibres dragged through it.

By repeating the operation described, it will be seen that there is formed at the receiving rolls *K* a scaly fleece, i. e., the ends of one tuft overlapping the ends of those preceding it, which is gradually moved onward towards a pair of drawing rolls *L*, by the step by step rotation of the receiving rolls *K*.

The drawing rolls *L* rotate simultaneously with, but at a greater peripheral velocity than the receiving rolls *K*, and they, therefore, produce a drawing action whereby the thick scaly fleece is converted into a thin uniform fleece or web.

After passing from the drawing rolls *L*, the web is delivered into the pan *M*, gathered into the trumpet *N*, and passed between a pair of condensing calender rolls *O*, turned at right angles around the guide post *P* onto the sliver table *Q*, and led up to a draw box with three sets of drawing rolls and then delivered to the coiler precisely as is done in the Heilmann machine previously described. The can of combed sliver is now ready for the subsequent processes of the drawing frame.

The waste combed out by the needles on the combing cylinder *H* is removed by the revolving brush *R*, and is in turn deposited upon the

waste doffer *S*, combed from the doffer by the comb *T*, and allowed to fall into suitable receptacles placed at the back of the machine for the purpose, or it may be wound upon a spindle or waste roll if preferred.

The upper jaws of the back and front nipper *F* and *J* are operated by suitable cams placed upon a shaft, which transmit their motion through the arms *U* and *W* and their connections *V* and *X* to the upper jaw arms *Y* and *Z*, to which the upper jaws of the nippers are attached.

With reference to diagrams Figs. 142, 143, 144, 145 and 146 the curved arrows denote the motion of each moving part, the radial arrows indicating that the roll in question is for the time stationary.

Let it be clearly understood that the combing cylinder *H* is constantly revolving in the direction shown by the curved arrows.

In Fig. 141 the rear portion of the needles on the combing cylinder *H* is shown finishing combing the front end of the tuft of cotton presented to it by the rear nippers *F*, the rear end of the preceding tuft of cotton being simultaneously begun upon by the front portion of the needles on the combing cylinder *H*; the front ends of said tuft being held by the front nippers *J*, and the rear detaching rolls *D* are beginning to rotate, to bring forward a new supply of lap, the front detaching rolls *E* being at the time stationary. The rear nippers *F* are closed and the bearing rolls *I* are raised out of the path of the combing needles on *H*. The front nippers *J* are closing, the receiving rolls *K* and drawing rolls *L* are stationary.

Fig. 142 represents the position assumed during the next step in the combing process. The last portion of the needles on the combing cylinder *H* has then passed by the nose of the front nippers *J*, and the fluted portion of the combing cylinder *H* is beginning to move under the bearing rolls *I*. The rear detaching rolls *D* are still revolving in a forward direction, and have, therefore, advanced the lap until it is near the front detaching rolls *E*, which are just commencing to rotate so as to carry the new tuft to be combed onwards to the nippers *F*, which are just beginning to open. The bearing rolls *I* are now beginning to descend, in order to carry forward the tuft, the front ends of which have already been combed. The combing of the rear ends of the preceding tuft is now completed. The front nippers *J*, the receiving rolls *K*, and the drawing rolls *L* still retain the positions unaltered, as shown in Fig. 141.

Fig. 143 illustrates the next step in the combing process. It will be seen that the continued revolution of the combing cylinder *H* has now brought the front edge of the fluted portion to the nose of the front nippers *J*. The rear detaching rolls *D* have now reversed their motion, and thus completed the detaching from the lap of another tuft of cotton, the tuft being carried along by continued forward revolution of the front detaching rolls *E*, which revolution pushes the new tuft between the jaws of the now fully opened rear nippers *F*. The needles on the combing cylinder are now entirely out of reach of the new tuft. The bearing rolls *I* have now entirely descended upon the fluted portion of the combing cylinder *H*, and are together carrying forward the preceding tuft, which,

so far, has been combed on one end only, and are about to convey it between the open jaws of the front nippers *J*. The receiving rolls *K* and the draft rolls *L* have commenced to rotate, carrying with them the previously combed fibres.

Fig. 144 illustrates the still farther continued rotation of the combing cylinder *H*. The first row of needles on the combing cylinder *H* is

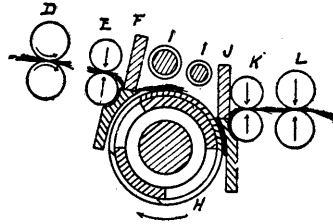

FIG. 142.

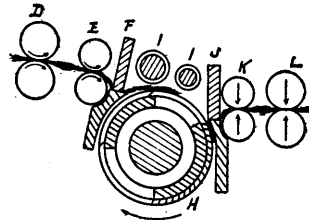

FIG. 143.

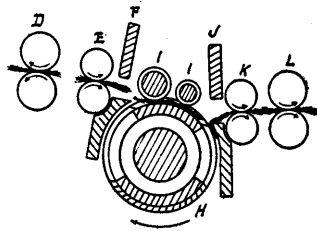

FIG. 144.

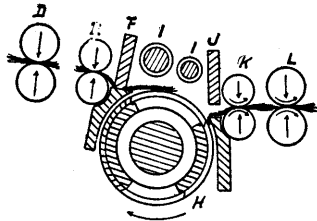

FIG. 145.

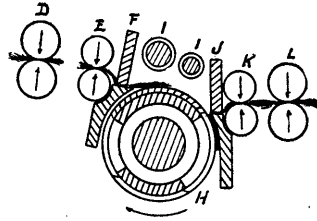

FIG. 146.

just entering the freshly introduced tuft last detached from the lap, which is held by the closed jaws of the rear nippers *F*. The front detaching rollers *E* have completed their partial revolution, and the rear detaching rollers *D* have finished their rearward rotation and are now stationary. The bearing rolls *I* are raised out of the path of the oncoming needles, the front nippers *J* are closing, and the receiving rolls *K* and the draft rolls *L* have just terminated their rotation.

When the parts assume the position shown in Fig. 145, the combing of the front end of the new tuft is being accomplished by the needles on the combing cylinder *H*, and simultaneously the front rows of the needles are about to begin combing the rear ends of the preceding tuft, which have not, as yet, been combed, and which are now held between the jaws of the front nippers *J*. The bearing rolls are still held up out of the path of the passing comber needles and the rear detaching rolls *D*, the front detaching rolls *E*, the receiving rolls *K*, and the draft rolls *L* being stationary.

The continued revolution of the combing cylinder *H* will cause the parts to resume then the positions shown in Fig. 141.

THE NASMITH COMBER.—The general principle of this machine is closely related to that of the Alsatian Comber, as previously explained, the chief point of similarity being that the feed roll, nippers and top comb are carried on a swinging frame, which is used in connection with the attaching operation. The various methods of obtaining the different operations of the several mechanisms on the machine, vary from those on the Alsatian Comber and are best explained by means of the accompanying illustration Fig. 147, which is a cross sectional view through the machine, showing the positions that the parts occupy when the swinging frame is stationary and at its greatest distance from the detaching rolls. The different mechanisms on the machine will be taken up in regular order for clearness as to the working of the machine.

The Nipper Frame and Plates.—The nipper frame 1, of which there is one at either end of the head, the two forming a pair, is pivoted on a fixed stud 2, and on which it oscillates, said stud being carried on the framing of the machine. These nipper frames receive an oscillating motion from an eccentric through a lever 3 and connecting rod 4, proper slots being provided in the frame for setting the stud 5 so as to vary the movement of the frame when desired. The bottom nipper plate 6, which is adjustable in a horizontal direction, is secured to the swing frame 1, by being carried by a bridge 7, which is screwed to said frame. Cast on the swing frame 1 and near each end of the bridge 7 is an arm 8, carrying a stud 9, on which are pivoted the movable arms 10, which are united by being cast together with the transverse bar 11, to which is screwed the top nipper plate 12. The whole nipper can be adjusted to the proper distance from the needles by a set screw 13. The lower extremities of these nipper arms carry rollers 14 and projections onto which are hooked the springs 15, whose outer ends pivot on arms of the bracket 16 as bolted to the back bar, the lower part of said bracket 16 having an inclined face 17 against which the roller 14 rests when being oscillated with the swing frame 1, and is thus forced to deviate from its arc, which action, through the pivot 9, opens the top nipper. Bracket 16 is adjustable in the vertical direction, and consequently the time when the nipper commences to open can be regulated. The path of the nipper in its passage from the combing position shown in the illustration,

to the detaching rollers is almost a direct line and departs as little as possible from the periphery of the combing cylinder 18, whose smooth surface, a little beyond the last row of needles, rises as high or even a little higher than the points of the needles, so that it supports the projecting tuft in revolving rapidly below it, and immediately the nipper opens, helps to direct the tips of the fibres of the tuft exactly to the nip of the detaching roller 19 and 20 on the one hand, while it also strokes the tail ends of the returned fibres gently below the bottom detaching roller 19. By thus keeping the path of the nipper close to the

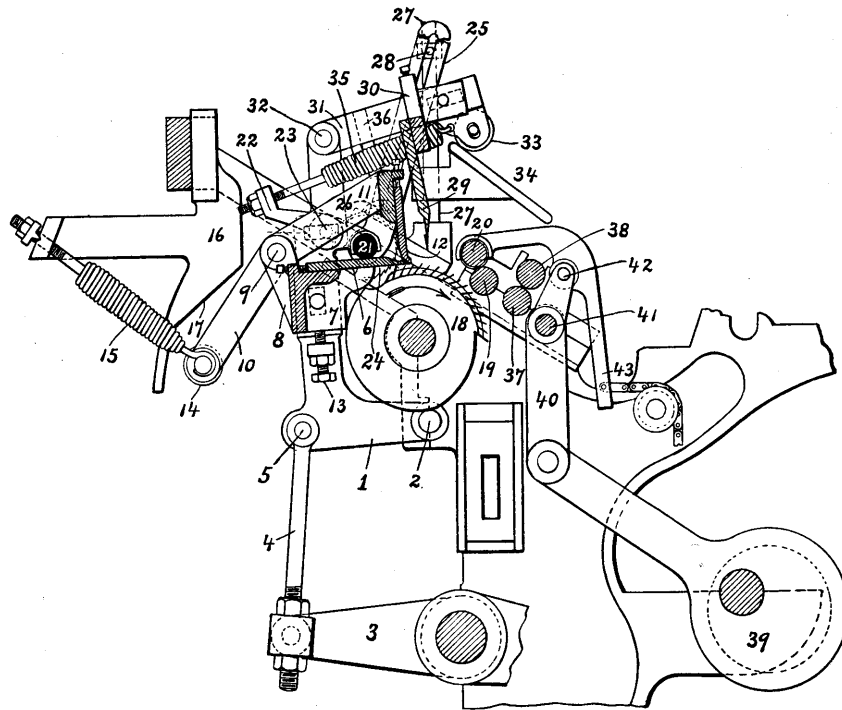

FIG. 147.

periphery of the cylinder an absolutely perfect piecing may be made from the simple motions of the nipper, cylinder, and detaching rollers combined.

The Feed Roller.—The feed roll 21 is carried by one end of a lever 22 as pivoted at 23, the other end of said lever 22 being spring controlled to keep the feed roll against the plate 6. The lever 22 can be adjusted in a horizontal slot, so that the distance of the roller from the top nipper plate 12 (and consequently from the nipping point of the detaching rollers 19 and 20 during the separation) can be regulated to suit the

length of the fibres to be combed. The easy adjustment of this distance is of great importance, as it effects the quantity of waste made, and the distance of the feed roller from the detaching roller, when at the nearest point, must only slightly exceed the length of the longest fibres. Fixed on the end of the feed roller 21 is a ratchet wheel 24 with fine teeth, and freely pivoted on the boss of this wheel is a lever 25, slotted for the greater part of its length and carrying the pawl 26. The pawl actuates the ratchet by having a vertical rod 27 fixed to the framing of the machine, and on which rod is an adjustable pin 28 to engage in the slot of the lever 25, and as the swing frame moves toward the nip of the detaching roller, said pin, prevents the forward movement of the lever at the point where it engages in the slot and thus causes the pawl to turn the ratchet. The vertical distance of the pin from the feed roller determines the number of teeth taken at one oscillation, and the position of the vertical rod 27 in relation to the arc of oscillation of the feed roller is such that the feed is greater the nearer the feed roller moves towards the detaching rollers. The detaching rollers 19 and 20 draw their supply principally from the bodily advance of the tuft projecting from the nippers, but they also obtain a supply due to the turning of the feed roller while said detaching rollers are turning forward. The feed roller is not brought up to a position in front of the detaching rollers and allowed to dwell there, only turning a little while the detaching rollers are drawing their supply, but it is carried bodily forward directly toward the nip of the detaching rollers, while at the same time it continues its feed by a partial revolution. There is, therefore, during the time the detaching rollers are turning forward, a double supply fed, due to the continued revolution and bodily advance of the feed roller.

The Top Comb.—The top comb 29 is carried on the transverse bar 30, bolted at either end to a top comb arm 31, as pivoted on the stud 32, fixed to the frame 1. The transverse bar 30 can be adjusted horizontally on the arm 31, and the angle may also be varied within the necessary limits. The arm 31 carries at its outer end a roller 33 which runs during a part of the oscillation on a guide plate 34, being held against said plate by means of a spring 35. Cast on the arm 31 is a projection 36, carrying a stop screw (not shown), which at the desired moment during the forward movement of the nipper, comes against the frame 1, causing the roller 33 to leave the incline 34, arresting its further descent, so that for the remainder of the oscillation, the top comb point follows a path parallel with that of the nipper. This permits the movement and depth of penetration of the comb to be regulated. The comb will penetrate the fleece gradually and sufficiently without descending too near the cylinder, owing to the fact that the fleece rises as it is drawn straight between the nip of the feed roller and detaching rollers, which straight line is considerably above the path of the nipper, being highest when the nipper is closest to the detaching rollers, owing to the roller 20 rolling on the top of 19 and to the rise of the feed roller and nipper as they approach said rolls. The position of the top comb pivot 32 with relation to the

points of the needles is such that the top comb does not fall in a direction parallel to the top nipper plate, but in a direction which approaches nearer to the nipper plate the lower the comb falls, and which approach may be increased by providing a slot in the frame 1 and the top comb arm 31, for the pivot 32. With this arrangement the comb may be caused to enter the tuft well in advance of the front of the nipper and still to be close to the nipper when the latter arrives near the detaching rollers, thus insuring that no part of the tuft shall escape being combed and still no room be lost, the nipper not being prevented by the top comb from approaching as near as required to the detaching rollers.

The Detaching Mechanism.—This motion consists of the two rolls 19 and 20 as previously referred to, and also the rolls 37 and 38. The fluted steel rollers 19 and 37 turn in stationary bearings; 38 is also a metal fluted roller resting on roll 36, by its own weight and in stationary guides. The detaching roller 20 is covered with cloth and leather, and receives a special rolling motion over the top of the roller 19, being always in contact with said roller 19. This roll is caused to move from a position slightly in front of an imaginary line drawn vertically through the centre of the roller 19 to one slightly behind that line and back again, by means of an eccentric 39 which imparts to the lever 40, fixed on a shaft 41, a rocking motion, which is imparted to the other end carrying a stud 42, on which pivots freely the lever 43, and consequently oscillates with the stud 42. The roll 20 being held by the arm 43 is kept in contact with roll 19 by having a chain attached to the lower end of said arm 43 with a weight hanging from it. The object of the movement of the roller 20 is threefold. First, it is rolled to the back of the roller 19 so that when the latter turns backward to deliver its tuft for piecing, the tips of the fibres thus delivered shall be projected against the revolving cylinder 18 and be stroked underneath the roller 19. Secondly, while in this position or thereabout, it may seize the fibres projecting from the nippers at the earliest possible moment. Thirdly, it is then withdrawn to the front of the roller 19 to permit as close an approach of the top comb and nipper to the nip of the detaching rollers as possible. In order to draw away the fibres as gripped by these rolls, it becomes necessary to greatly increase the forward motion of said rollers. The method of operating the rolls is similar to that explained for the Heilmann Comber, and need not be discussed further.

The Operation of the Machine will be best understood by following the different movements through one complete cycle of operations. In the illustration, the nippers are shown closed and at the point where the forward motion toward the detaching rollers begins. At this time the fine needles composing the rear rows of the cylinder needles are passing through the tuft of cotton projecting from the nippers. After the rows of needles have passed the fibres, the smooth part of the cylinder comes under and supports the projecting fibres, which are already advancing with the nipper, and by the motion of said cylinder, keeps the fibres stroked out toward the detaching roller. The fibres, owing to their

elasticity, will not lie close to the cylinder, but are pointed slightly upward, and immediately that the nipper is opened, they rise still higher, pointing directly toward the nip of the detaching rollers. The opening of the nipper is caused to happen just before the tips of the fibres touch those which have been partially returned by the detaching rolls and stroked by the cylinder around the roll 19. The moment the tips of the fibres touch the fibres on the roller 19 (or an instant before) the rollers 19 and 20 begin to turn forward and the projecting fibres are instantly seized and drawn straight, coming against the points of the top comb needles, which are descending to meet them. The nipper, feed roller, and top comb continue their forward motion directly toward the nip of the detaching rollers as long as the latter turn forward, while at the same time the feed roller continues to feed the lap as long as it moves toward the detaching rollers and the top comb continues to penetrate deeper into the lap as it advances, partly owing to its further fall on the incline plate till arrested by the set screw, and partly owing to the rise of the fibres due to the motions of the nipper and the detaching rollers in the detaching mechanism. The forward oscillation of the nipper and other parts improves the feed and prevents pulling apart of the lap. The nipper having arrived at the forward extremity of its path instantly commences to return, and a brief instant afterwards the rollers 19 and 20 cease to turn forward, the latter having also arrived at its extreme forward position, and, holding the fibres firmly between them draw them out through the top comb, from the retiring tuft of lap as projecting from the nippers, thus making a clean separation. When the separation is completed, the top comb rises, and in doing so also moves a little away from the nipper, owing to the position of the top comb pivot 32. This movement is not enough to leave any fibres in the front of the top comb, but is sufficient to draw backward the seeds, neps, etc., engaged therein, so that the comb remains automatically clean. The closing of the nipper finally throws the fibres out of the comb and into the first rows of coarse needles on the cylinder, which are now meeting the retiring nippers, so that the tuft is thrown well into them by the motion, which, however, ceases before the fine needles on the cylinder reach the fibres. Before the fine needles have passed through the tuft, the forward motion of the frame carrying the nipper has again commenced, so that it is moving with the cylinder, preventing the fine needles from roughly tearing the fibres and weakening the yarn to be spun from them. The cycle of operations continues to repeat itself as long as material is supplied and machine kept in motion.

DRAWING.

The cotton, after having passed through the carding or combing process, as the case may be, is next subjected to the process of drawing. Although the process of drawing is very simple in comparison with the other processes in the manufacture of yarn, yet it is one of the most important in the production of perfect yarn. The machine for doing the work is known as the Drawing Frame, a perspective view of which is given in Fig. 148.

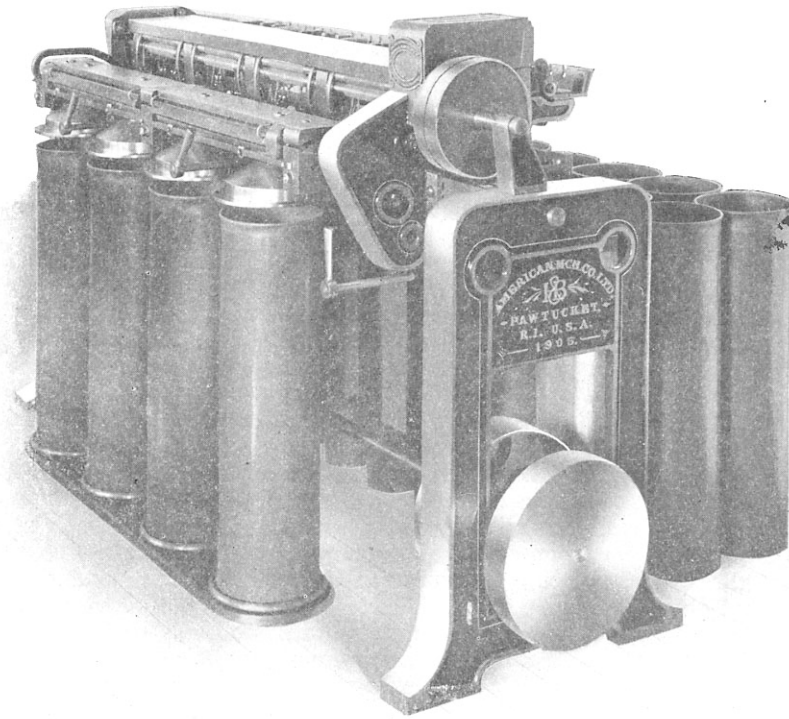

FIG. 148.

Broadly speaking, there are, in every process through which the cotton passes, two objects that are aimed at, the first one being to carry the cotton under operation a step further toward the final product in the

process of manufacture, the second being to eliminate as far as possible all defects which are in the cotton, after said cotton has passed through the preceding processes.

With reference to the carded sliver, the main defects to be corrected, are the more or less tangled condition of the fibres composing the sliver, which is due to the manner in which the cotton is taken from the cylinder by the doffer, but which is necessary in that machine in order to give the sliver enough strength to be properly delivered from it, and the unevenness of the sliver produced which is unavoidable, owing to the unevenness of the scutcher lap which is fed to the card. The cotton after being carded by cylinder and flats is then condensed on the doffer, for the reason that the cylinder has a circumferential speed of over 2000 feet per minute, while the doffer has only a circumferential speed of less than 100 feet per minute, or in other words, the doffer has to take on its surface about 20 times the amount of cotton as is on the same surface of the cylinder, a feature which cannot help but cross and overlap individual fibres in the film of cotton as stripped from the doffer by the stripping comb, the latter process still further disarranging the former parallel condition of the fibres, which thus are delivered from the card in the shape of a sliver of more or less crossed and disarranged fibres. However, this sliver has a great advantage in the fact that the fibres composing it are not entangled with one another, since in the previous process of carding they have been separated, and consequently will readily assume a straightened and paralleled position if the sliver be pulled slightly end ways.

In the case of the sliver as made on the comber, the fibres composing it have by that process been set almost parallel, so that the principal defect to remedy at drawing, is the more or less unevenness in the slivers.

The tangled fibres in the carded sliver, which cross each other in all directions, are in the process of drawing placed into approximately parallel order by means of the drawing rolls in the machine, the method employed being to have each succeeding pair of rolls toward the front of the machine, revolve at an increased speed over that pair of rolls which is just back of it, this procedure producing what is technically known as *draft*, the sliver thus being drawn out and the fibres in this manner being laid straight and parallel.

The distance between the individual pairs of rolls must be somewhat over the length of staple under operation, since otherwise the cotton would suffer, resulting in a weak yarn. The distance to set these rolls differs with the speed of the machine, for example, in the case of a high speed as compared with a low one, a wider space will have to be allowed, since otherwise the pull of the front rolls coming so rapidly on the fibres, almost before they leave the back rolls, will tend to break them, or more likely pull the fibres through in a lump, i. e., without drawing them. The same would also occur in connection with a heavier weight of sliver, and when by gripping such a mass of cotton at

such close quarters, the tendency would be to break the fibres, although impossible, owing to their number, and which then will result in the fibres being pulled through the rolls in tufts instead of an even layer.

The sliver is worked into a more even and uniform condition by the system of doubling slivers at the back of the drawing frame, which slivers are then fed to the drawing rolls and after passing them are condensed into one sliver at the front of the machine, this principle of doubling being identical with doubling laps in the scutcher or slivers in the sliver lap machine; that is, by combining several of the slivers into one sliver they have a tendency to equalize any defect in the evenness of individual slivers, from the fact that thin places in one sliver come opposite thick places of another sliver, to a more or less degree, and thus tend to produce a more uniform final sliver. This principle of doubling, which makes a more uniform sliver, is best proved by the practical result obtained on the machine.

The drawing frame generally consists of four, six or eight deliveries, each delivery consisting of the drawing rolls and the coiler head arrangement which condenses the six or eight slivers, which were fed to the machine into one sliver and delivers it into the can. A number of deliveries (generally six) makes up a head, there being several heads in the machine.

The slivers fed to the machines are referred to as "ends," and the machine is described as having 6 or 8 "ends up." A machine of 6 deliveries with 6 "ends up" for each delivery will take its stock from 36 cans of carded or combed sliver, as the case may be, and deliver "drawn sliver" into 6 cans.

Drawing frames, like all other textile machinery, are known as right or left hand machines, the "hand," as indicating the position of driving pulley of a drawing frame, being determined by standing in front of the machine where slivers are delivered and noting position of driving pulley on front roll. If it is on the right, it is a right hand frame, if it is on the left, it is a left hand frame. The number of processes of drawing which the slivers undergo varies from two to four, the most general number being 3, the latter being known as "three process drawing," indicating that the sliver has been drawn and delivered three times. When using two or four processes of drawing, it is termed respectively "two" or "four process" drawing.

Weak yarn may be caused by having the cotton overdrawn, as in that case the fibres composing the sliver are strained until their natural convolutions are destroyed to such an extent that the fibres will become brittle, and slide over instead of interlocking with each other in case the thread is subjected to a strain. When the cotton under operation is soft and the numbers to be spun from it do not exceed 32's, two processes of drawing, doubling eight ends in each delivery, which is equal to a total of sixty-four doublings, will often be found to produce satisfactory work. When three process drawing is used, six doublings for each process are made, giving a total of 216 doublings in the complete drawing

process. Four process drawing is very rarely used, except when working a long stapled cotton, as Sea Island. If more than a total of 216 doublings is required, either eight doublings are made on one delivery, with six on the other two (= 288 doublings), or if desired, eight can be made on each delivery, thus giving a total of 512 doublings. From this it will be seen that short stapled cotton does not require as much drawing as long stapled, for the reason that the short fibres are less liable to double up and become as tangled in carding, as in the case with the long fibres. The proper setting of the drawing rolls in the frame for the different lengths of staple is very important, and neglect in this particular will effect seriously the proper running of the machine. The sliver from the last process of drawing should have a silky lustre, and the fibres composing it should be perfectly parallel with the length of the sliver produced. The waste which is made in the operation of drawing is very small, and any excess of waste made there can be traced to the negligence of the operator or to a fault in the machine.

In the description of the working of the machine which will be given, only one delivery will be dealt with, as the various deliveries in the frame are all duplications, and what is said of one applies to all deliveries in the machines.

A cross section of the working parts of a delivery (referring to the drawing frame as built by the Saco and Pette Machine Shops) is given in Fig. 149, showing clearly the course of the cotton slivers through the machine and the relation of the different parts to each other.

The machines for the first process are placed as near as is convenient to the delivery ends of the cards, or where combers are used, near their delivery ends, and the cans which are filled from them are placed at the back of drawing frames, and six or eight slivers, as the case may be, are passed up through guides *A* at the back of each delivery, passing between a pair of single preventer or tension rolls *B* and then over the spoons *C*, each sliver passing through a separate spoon, over a guide *A'* to prevent the sliver from sagging, to the back pair *D* of the drawing rolls. From there the slivers pass, side by side, through the three succeeding pairs of drawing rolls *E*, *F* and *G* respectively. Between the pairs of rolls *D* and *E*, there is a small draft given to the slivers, between the pairs of rolls *E* and *F* the draft given to the slivers is slightly increased, the same being considerably further increased between the pairs of rolls *F* and *G*; the total draft between the four pairs of rolls being equal to about 6 when doubling six slivers, and about 8 when eight slivers are doubled, as is the case in some instances. This will give practically the same weight to the sliver from each delivery as that of a card or comber sliver as fed to the machine. On emerging from the front pair of drawing rolls *G*, the drawn slivers are passed to the trumpet *H* in front of the machine and finally condensed into a single sliver, passing in turn downwards between the calender rolls *I* to the coiler head *J*, which coils it into the can *K*. This can, on being filled with sliver from the first process of drawing, is taken to the back of the second process drawing frame, together with other

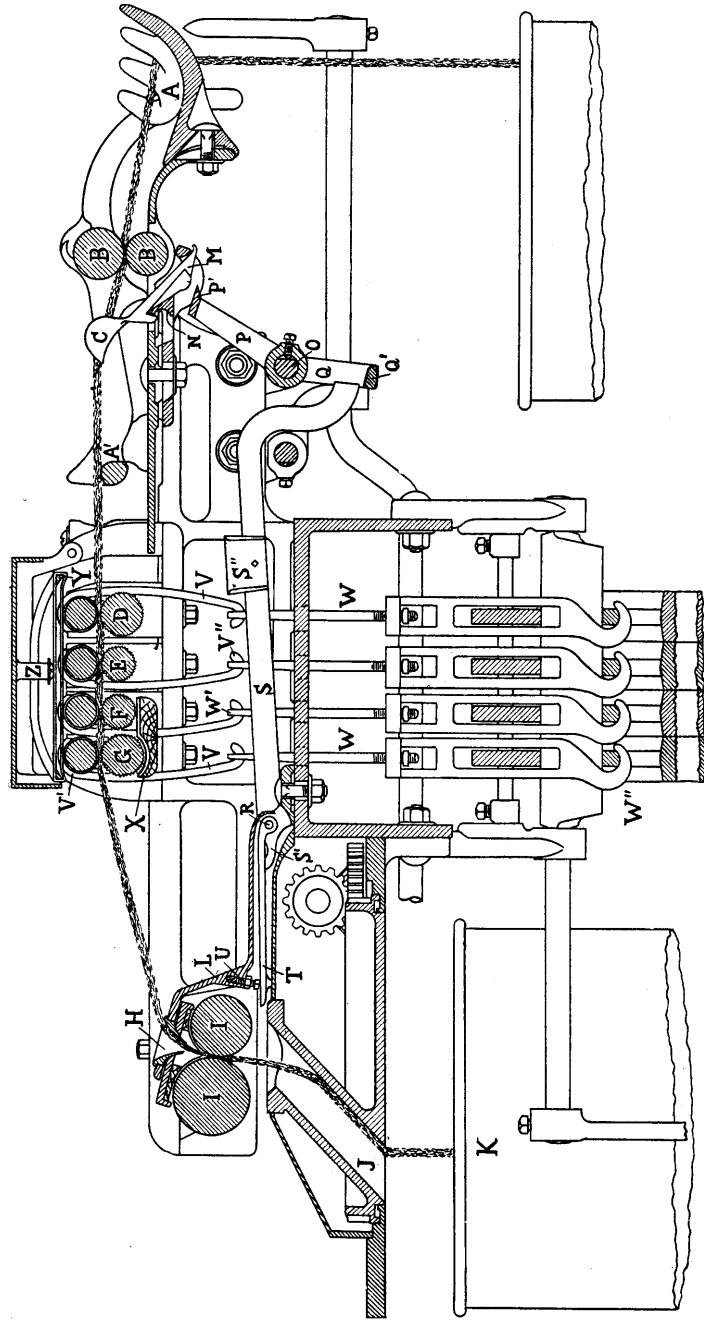

FIG. 149.

similarly filled cans, and fed to said machine. In the same manner the full cans from the delivery end of the second process drawing frame are placed at the back of the third process drawing frame and in turn fed to this machine. Theoretically one set of drawing frames could be used by passing the sliver through the same machine three times, but from a practical standpoint it would not work.

Two methods of positioning the frames for the three processes of drawing are in use, known respectively as "Straight" and "Crossed" arrangement. The straight arrangement is shown by means of Fig. 150 in a plan view. *A*, *B* and *C* respectively indicate the three frames called for. *a* refers to the respective cans as placed at the back of each delivery. In the present instance we have shown the cans placed four rows deep as is customary when using 12" cans. In connection with 10" cans they may be set three rows deep in order to make feeding handier. *b* indicates the coilers in front of each delivery. The arrow *D* indicates the direction of the passage of the cotton through this 3-process system of drawing. In case only 2-process drawing is used, frame *C* is omitted, whereas in a 4-process system an additional frame is added. The crossed arrangement is shown in Fig. 151, the letters of reference being selected to correspond to those in Fig. 150 in order to more readily explain the difference between the two arrangements, the frames being set end to end, fronting first one side and then the other. This method of setting drawing frames is also known as the "Zig-zag" setting, it being used in smaller mills where the floor space available is suitable for it.

Referring again to Fig. 149 we find that the guides *A*, at the back of each delivery, through which the slivers pass in their travel to the drawing rolls, are made with upright fingers having spaces between them in which each sliver moves, the object for it being to keep the slivers separated from each other and thus guided into their correct position (prevent their crossing each other) with reference to the spoons *C*.

When a sliver breaks at the back of the machine, the end from the can should always be spliced if possible with the end hanging behind the rolls, but very often it happens that the stop motion does not act until the end has passed between the rolls, and when the sliver has to be started in the best manner possible. In order to prevent this trouble, i. e., to have the machine stop before the depending end passes between the rolls, a pair of single preventer rolls *B* are placed at the back of the machine, between the guides *A* and the spoons *C*, a slight draft being present between the back pair of drawing rolls *D* and this pair of preventer rolls *B*, so as to keep the slivers in a slight, even tension in their passage to the drawing rolls, which tension otherwise would be more or less irregular. When a sliver breaks on a frame using this roll, the breakage occurs in most all cases behind this pair of preventer rolls, so that immediately when the end of the sliver passes through the preventer rolls, the spoons act to stop the machine, ample length of sliver for piecing thus being left. Tension on the slivers also has the advantage of causing the stop motion to act more quickly, and also prevents the

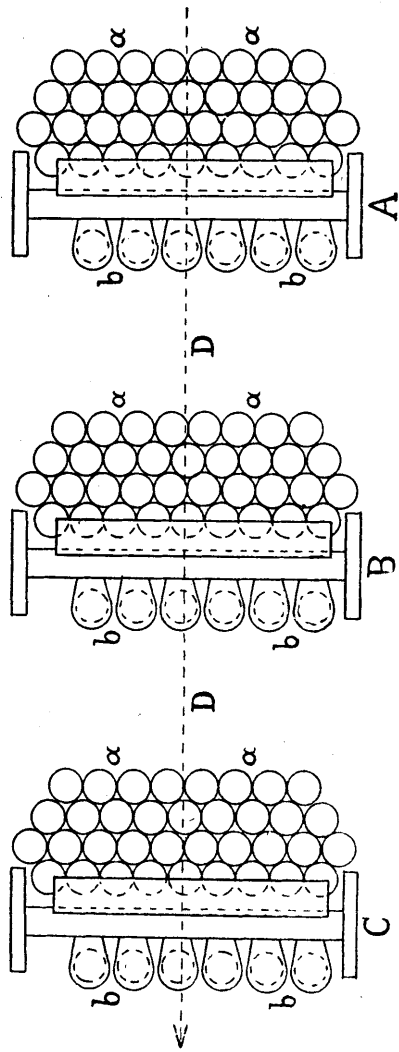

Fig. 150.

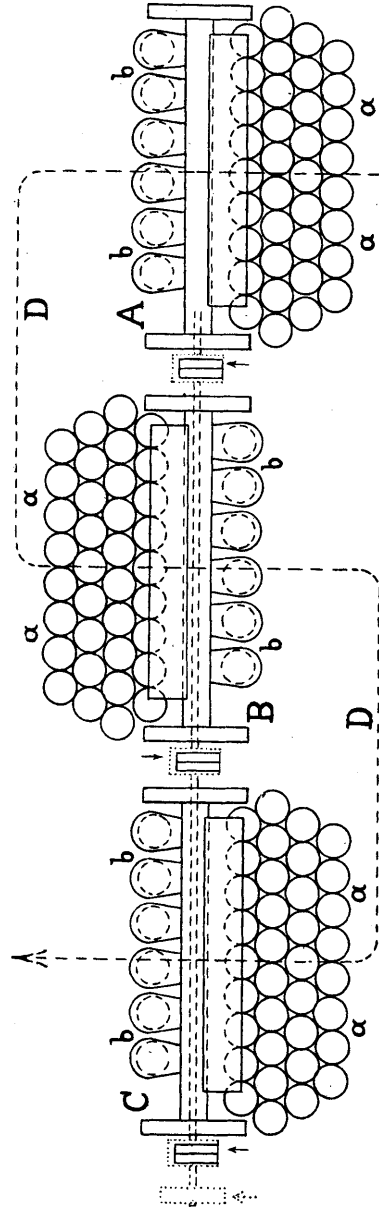

Fig. 151.

latter from acting by preventing a slack sliver from passing over the spoon and cause it to drop in the same manner as if the sliver were broken.

The slivers, on passing through the four pairs of drawing rolls *D*, *E*, *F* and *G*, are, as mentioned before, subjected to an increasing draft between each successive pair of rolls. The reason for making use of this system of drafts is a very important one. A number of carded or combed slivers are fed at the back of each delivery at the same time, or as is sometimes said, the slivers are doubled at the back of each delivery, and on reaching the drawing rolls, they consequently form a thick strand of cotton. By subjecting the slivers at this point to an excessive draft, it would have a tendency to injure the fibres; but by having the first draft small and the second slightly larger, the fibres under operation are gradually pulled into an approximately parallel order. The slivers have then been subjected to a draft of a little over 2, and the consequent attenuation of the slivers has been very gradual, thus not injuring the fibres, but putting them in such a condition that they can readily be subjected to the increased draft between the second, third, and front rolls.

The drawn slivers, on emerging from the drawing rolls in the form of a thin sheet are passed through a trumpet *H*, this trumpet being secured to a pivoted arm *L* which is a part of the front stop motion on the machine. When cotton is absent in the trumpet, the stop motion acts to stop the machine, since if there was no stop motion, the sheet of cotton after breaking down in its passage to the trumpet, would pile up in front of the rolls or in some cases would wind around the rolls and thus cause a waste of cotton, as well as loss in time in cleaning the matted cotton from the rolls.

The object of the calender rolls *I*, through which the condensed sliver passes from the trumpet *H*, is to draw the sliver through the trumpet and deliver it to the coiler head *J*, and also to further compress the sliver so as to give it more strength.

The coiler can *K* is placed on a slowly revolving stand in order that the next circle of delivered sliver is not deposited bodily upon the one delivered before it. The can thus revolving very slowly and in the opposite direction to that of the coiler tube, in this manner lays the circles of sliver side by side in the can until the same is filled.

The relation of gearing between coiler and can table must be such as to obtain the most regular and compact condition for the coils, so that on withdrawing the sliver from the can, in the after process, broken ends as well as strained portions to the sliver will be avoided. On account of the sliver being delivered down the coiler tube, and through the coiler rotating, the latter describes a circle, and as the sliver in the can follows the same path, the sliver will consequently be twisted once for each coil, or about once in every 20 to 25 inches, according to the size of coiler used. For example, take a coiler as is used for a 12 inch can, the diameter of the coiler in this instance being $7\frac{1}{8}$ inches. Thus $7\frac{1}{8} \times 3.1416 = 24.54$

inches, amount of sliver delivered in one revolution of the coiler, i. e., one turn or twist in every $24\frac{1}{2}$ inches of sliver.

The centre of the can is not directly under the centre of the top of the coiler tube, since if this was the case the coils would be laid in a circle, a little larger than half the diameter of the can, around the centre of the can, and not touch the edges, producing in this manner a coiling which would collapse and become entangled. To prevent such a trouble, the centre of the can bottom for a 10" can is moved forward $1\frac{1}{2}$ " from the centre of the top of the tube, and that for a 12" can about 2 inches. This method of placing the can out of centre line with the coiler will be readily seen on referring to Figs. 169, 170 and 171.

Single and Double are terms used in connection with drawing, indicating by the first a light sliver caused by one or more ends having been left out at the feeding end of the frame. If, for example, 6 ends up at the frame for one delivery produce a standard sliver delivered, then if one end is left out from any cause, the product made during that period would be called single. Double is the reverse of the preceding and is made where an extra end from any cause is fed to the frame.

STOP MOTIONS.—Probably more time has been expended on improvements in the different stop motions on the drawing frame than any other mechanism connected with it, the results obtained always tending towards simplicity and positive working of the motions. There are at the present time four stop motions used in connection with a drawing frame, each controlling the sliver at different points in its passage through the machine.

The first stop motion of the machine, which controls the feeding of the slivers to the drawing rolls, is situated at the rear of the machine and is known as the *Back Stop Motion*. The value of this stop motion cannot be over-estimated as the evenness of the delivered sliver is almost entirely dependent on it, because of the fact that six slivers are doubled at the back of the drawing rolls in order to reduce the irregularity in each sliver by incorporating them into one sliver, and it will be readily seen that if one of these six slivers is absent for a short space of time, the resulting sliver will be one sixth lighter than it should be, and hence this irregularity would be worse than irregularity in the carded or combed sliver, and when consequently one of the main objects of the process, i. e., to produce an even sliver, would be lost.

The second stop motion met with in the machine is the *Front Stop Motion*, the object of which is to stop the machine in case the film of cotton breaks between the front rolls and the trumpet, thus preventing waste and the liability of the cotton lapping around the front rolls.

A *Full Can Stop Motion* is also provided at the front of the machine, the object of which is to automatically stop the frame when a can has become sufficiently full, so as to prevent any damage to the sliver or the machine.

In connection with a special type of Full Can Stop Motion, a stop

motion is used to prevent the sliver from accumulating between the calender rolls and the coiler when it breaks at that point or its passage through the coiler is impaired.

All of the stop motions are more or less connected to each other and some of the parts are therefore common to all. Both mechanical and electrical arrangements are made for operating the motions, a view of mechanical motions being shown in connection with the cross section of a drawing frame in Fig. 149.

Back Stop Motion.—On referring to this illustration Fig. 149, it will be seen that each sliver passes from the pair of single preventer or tension rolls *B* over a spoon shaped lever *C* in its passage to the drawing rolls. This spoon is grooved at the top, so that a sliver can easily pass through it, the bottom of the spoon being provided with a slight projection *M*. The spoon is balanced on a knife edge *N*, and the bottom end is made slightly heavier, so that when a sliver is absent in the spoon, the bottom end *M* will drop, but while the sliver is passing through the groove, the weight and tension of the sliver is sufficient to overbalance the bottom end and keep it raised. Situated under the spoon is a vibrating shaft *O* carrying levers *P* and *Q*, the first one supporting a knife edge *P'*, the bottom one *Q* carrying a rod *Q'*; both knife edge and rod extending under all of the spoons on the frame. Vibratory motion is given to the shaft *O* in some machines through connections with an eccentric at the front of the frame, or as in the machine shown in the illustration, through a forked lever (not shown) connected to the shaft *O* and receiving motion through a gear at the back of the machine, said gear carrying a stud fitting into the forked end of the lever. In both cases, the levers are double fulcrumed, and when a sliver breaks, thus allowing the end of the spoon to drop and stop the vibration of the knife edge *P'*, the lever "breaks" at one fulcrum owing to the fact that the power which vibrates the lever continues to act, and when the lever breaks, one portion of said lever comes in contact with a lever to which is secured the belt shifter and thus throws it off of its catch, a spring which is attached to the framing and also to the lever, then acting to throw the lever backward, thus shifting the belt from the fast to the loose pulley, in turn stopping the machine.

The Front Stop Motion is related to the back stop motion, in that the same vibrating shaft *O* is used, and the machine is stopped through the same mechanism in connection with the belt shifter. The trumpet *H* forms a part of this stop motion and is secured in the lever *L*, which is fulcrumed at *R* on the framing, a short distance in front of the drawing rolls. Fulcrumed at the same point *R*, and extending toward the back of the machine is a lever *S* which has a short projection *S'* extending under the front lever, said lever *S* being provided with a movable weight *S''*, which has to be set so that the lever *S* is slightly heavier than the front lever *L*. When the sliver is passing properly through the trumpet

H, the latter is held down by the tension of the sliver and the end of the back lever *S* is held out of the path of the vibrating rod *Q'*, so that the movement of the latter is not interfered with. However as soon as the sliver breaks at the front of the machine, the lever *S* drops, owing to its weight, and comes in the path of the vibrating rod *Q'*, arresting its motion, and in the same manner as explained in connection with the back stop motion, the machine is stopped. Sometimes in changing from coarse to fine work, or in other words, from a heavy to a light sliver, in addition to raising the small end of the trumpet from the calender rolls, the trumpet itself has to be changed. This is on account of the sliver being so light, and the small end of the trumpet so large that the sliver would not be condensed, and the friction and weight of the sliver would not be sufficient to keep the trumpet in its proper position, and thus cause the frame to be stopped continually.

The Full Can Stop Motion is operated by the coiler *J*, by having a lever *T*, which is fulcrumed at the same point *R* as the trumpet and back levers *L* and *S*, rest on the top of the coiler, and as the can *K* fills it finally pushes the coiler upward which then comes in contact with the lever *T* which is in turn pressed against a screw *U*, projecting from the trumpet lever *L*, and raises it. The lever *L* then acts in the same manner as if the sliver at the front of the machine had broken, and by the back lever *S* falling and coming into the path of the vibrating rod *Q'*, the vibration of the latter is arrested and the machine stopped in the same manner as with the other stop motions explained.

The arrangement of a stop motion, in connection with the full can stop motion, as built by the Mason Machine Works, to prevent a bung-up between the calender rolls and the coiler, is shown in Fig. 152, which is a side elevation partly in section, showing the positions of the parts of the stop motions in their normal places. The full can stop motion consists essentially of the coiler *A*; the upper part of which extends into the coiler cover *B* on which rests a lever *C* as secured to the shaft *D*. Fulcrumed also on this shaft *D* is a lever *E*, one end of which rests against a set screw *F* in a lever *G*, rigidly but adjustably secured to the shaft *D* by means of a set screw, the other end *H* of lever *E* extending toward the back of the machine, having a catch or hook *M* at the end, which is held just out of the path of the vibrating rod *I*. When the can becomes full enough, the cotton presses the coiler *A* up and the cover *B* in turn raises the lever *C* which partially rotates the shaft *D*, in turn raising lever *G* and screw *F*, thus allowing the lever *E* to rise, which causes the arm *H* to drop, and when the catch or hook *M* on its end engages with the vibrating rod *I*, arresting the motion of the latter, which through suitable lever connections shifts the belt from the fast to the loose pulley. The stop motion for preventing cotton from accumulating between the calender rolls and coiler, makes use of the full can stop motion by having a lever *J* attached to a projection *K* on the lever *C* on either side, with a slot between, so as to allow the end of the lever *C* to raise up through it.

The lever *J* is also provided with a bend *L* which acts as a pivot for the lever *J*. The end of the lever *J*, which projects over the coiler tube, is provided with a hole through which the sliver passes. When the sliver is

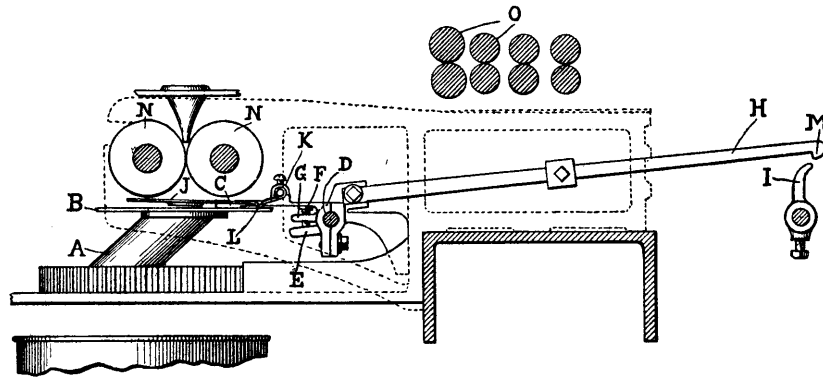

FIG. 152.

running properly, the lever *J* is in the position shown in the illustration, but when cotton accumulates between it and the calender rolls *N*, said lever *J* is pressed down by the pressure of the cotton, its bend *L* acting as a pivot, causing the end which is attached to the lever *C* to raise it and thus rotate the shaft *D*, thus stopping the machine in the same manner as previously explained.

A cross section through the drawing frame as built by Dobson and Barlow is given in Fig. 153, showing very clearly the arrangement of the different stop motions, the letters of reference indicating the parts as follows: *A* Sliver Plate, *B* Spoon, *C* and *D* Back Roll Motion, *E* Sliver Guide, *F* Back Roll, *G* Third Roll, *H* Second Roll, *J* Front Roll, *K* Front Stop Motion Top, *L* Brass Funnel for Front Stop Motion, *M* Eye Glass for Front Stop Motion, *N* Stop Motion Foot, *P* Eccentric, *Q* Knife for Spoon Motion, *R* Eccentric Arm Elbow, *S* Eccentric Arm, *T* Knocking-off Catch for Stop Motion, *U* Bracket for Catch for Stop Motion, *V* Rocking Shaft Lever, *W* Feeder Bar, *X* Catch on Feeder Bar.

The back stop motion in this make of drawing frame acts on the same principle as the spoon lever arrangement previously described, and when a sliver breaks, the lower end *O* of the spoon *B* drops and comes in the path of the vibrating arm *Q* and stops it from vibrating, the continued movement of the eccentric, (shown in dotted lines) causing the arms *S* to raise and come in contact with the upper portion of the knocking-off catch *T*, which in turn is raised, and the shaft *U* which is kept in position by the catch, is released, and a strong compression spring placed upon it, acts through suitable stops on the strap fork rod and so changes the strap from the fast to the loose pulley, which stops the frame. The front stop motion in this machine is composed of the

trumpet *L* secured on a lever centred at *M*, the other end of which projects downward just far enough to be out of the path of the oscillating

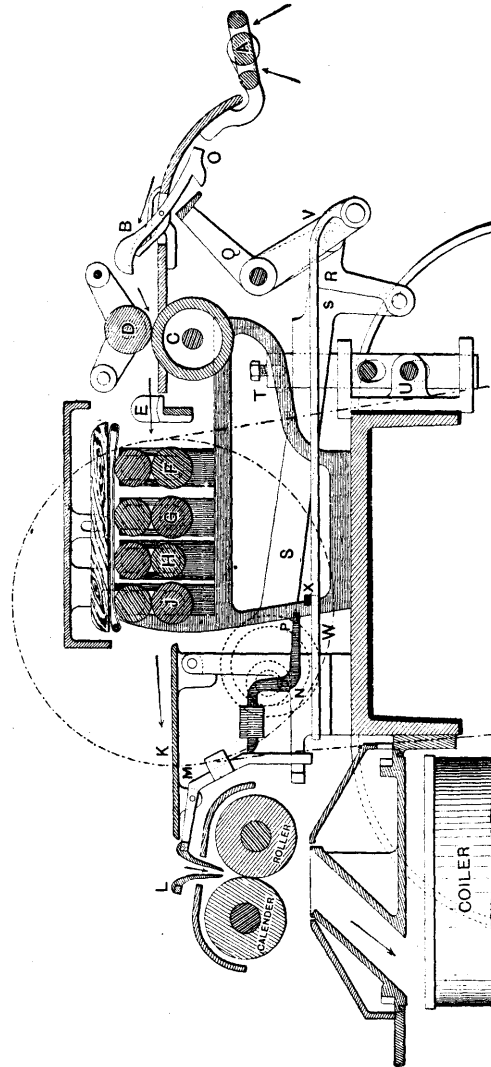

Fig. 153.

lever *W* when the sliver is passing properly through the trumpet. When the sliver breaks, the end of the lever centred at *M* drops, owing to its weight, and comes in the path of the oscillating lever *W* and stops its

movement. Lever *W* being connected at its other end to the vibrating lever *V* thus stops the machine in the same manner as with the back stop motion previously explained. When the sliver is too heavy, the trumpet *L* is pressed down too far and thus causes the other end of the lever to raise the end of a lever centred at *N*, and hence the lower end *P* of said lever will drop and come in contact with the catch *X* on the oscillating lever *W* and stop its motion, thus stopping the machine in the same manner as just explained.

Electric Stop Motions are also extensively applied to drawing frames (see Fig. 148) in the place of the purely mechanical stop motions just dealt with. The use of levers in connection with these stop motions is curtailed to a considerable extent, and in its place the principle of the electric circuit substituted. With reference to the back stop motion the spoon levers and their connections are not used, rolls being employed in their place, the calender rolls taking the place of levers in the front stop motion. The fact that cotton is a non-conductor of electricity, or in other words will not carry an electric current, makes the working of the electric stop motion feasible. Electricity is not operative unless it can have a continuous flow or the circuit is completed, and therefore if one pole of electricity is situated on one part of the machine and the other pole in a part of the machine where it is not connected to the first pole, there can be no current until the parts come in contact, and thus complete the circuit. This is what is provided on the drawing frame applied with electric stop motions, that is, one pole from a small dynamo is connected to the top part of the frame and the other to the lower part, proper insulation being placed on the machine where a circuit could be formed, except between the rolls where the cotton passes and in itself provides proper insulation, so that there is no current when the cotton is passing through the machine properly. However, when the cotton breaks and is absent from between any pair of rolls in the machine, then contact of the two parts takes place, the circuit is completed and the current is produced. Situated on the circuit is an electro magnet, which, when a current of electricity passes through it, becomes magnetized and will attract iron, for which reason a swinging iron lever is placed close to the magnet and when in its normal position is just out of the path of a revolving catch. When the magnet becomes magnetized through the completion of the electric circuit, the lever is attracted by the magnet and thus comes into the path of the revolving catch referred to, thus stopping its rotation, and when through suitable lever connections, the belt is shifted from the fast to the loose pulley and the machine stopped.

The back stop motion is made with a single bottom roll over which all the slivers pass. On top of this roll there are separate rolls for the slivers, so that when a single sliver is absent, the roll drops upon the bottom roll and forms a contact, thus completing the electric circuit and stopping the machine in the manner as previously explained. Situated a short distance above the front top drawing roll is a screw, and when the

cotton should lap around this roll, it is raised, and comes in contact with the screw which then completes the electric circuit and when the machine is stopped in the usual manner.

The Dynamo for generating the electric current can be driven either from the machine, or from the line shaft, according to convenience for its position. In place of a dynamo, cells for generating the electric current are sometimes used, being placed conveniently to the machine and having wires connected to conduct the current to the upper and lower part of the frame.

In order to keep an electric stop motion in proper working order remember:

If the machine becomes short circuited before the current reaches the electro magnet, the stop motion will not operate when an end breaks, since the current returns through the short circuit.

Be sure that the metallic connections are screwed tight, since otherwise the stop motion will not operate (no circuit).

The contact springs must be kept bright and free from oil, since otherwise the electric current will be prevented from flowing beyond the contact block.

Do not place oil on the top electric rolls, for if sufficient oil gets on the top rolls to form a film over its surface, if the sliver should break, allowing the top roll to come, in the ordinary manner, in contact with the bottom roll, the machine would not stop (oil being a non-conductor thus prevents the flow of the current, the same as the cotton did before).

Should a circuit take place, by having any of the parts as connected to the different poles come in contact with each other, the effect would then be similar to a sliver being absent, as the current would flow and thus keep the machine stopped.

The stop catch should always be within $\frac{1}{32}$ " of the knocking-off cam in order that the machine is stopped quickly.

In comparing the two types of stop motions, the mechanical has the advantage that its mechanism is more readily understood and kept in proper working order by the average workman, while some familiarity with electricity is necessary in dealing with electric appliances of any description. However, in favor of the electric stop motions is the fact that there is less mechanism connected with it, and when in proper working order its action is almost instantaneous.

DRAWING ROLLS.—From the description of the drawing frame and from its name, which indicates the process, it will be seen that the principal feature of the machine is that of drafting or drawing the sliver, and hence it will be seen that the drafting or drawing rolls of this machine become the most important parts for consideration when studying its details. These rolls, as in all cases where a draft is produced, work in pairs in connection with other pairs of rolls, each pair consisting of a top and bottom roll, revolving in contact with each other when the machine is in operation.