

which is shown in our illustration) are placed above the apron, and both receive the reciprocating motion. When spinning long-stapled wool a common custom was and is, to cover the rolls with fine metallic wires, so as to have the same act more powerfully in condensing the ribbons

**Bolette Condenser—Method of Operation of the Machine.**—This device is intended to substitute the ring-doffers previously explained. In the Bolette condenser only one doffer-cylinder is used. The principle of dividing the film combed from it into the characteristic fine ribbons (later on condensed by means of rubbing in roving) is as follows: On the side of the device standing nearest the doffer are two horizontal rollers of cast iron, one above the other, but at considerable distance (about twelve inches) apart. These rollers are grooved at regular intervals in such a manner that the grooves of one are exactly opposite the spaces on the other roller, and there must be, considering both rolls, as many grooves as fine ribbons are required to be delivered. Closely fitted in these grooves and fastened at one end are bands of steel (blades) of such a width as the proper number of divisions will admit of. The usual number for a 48-inch card is 96 ends or bands, exclusive of the waste ends, and for a 60-inch card, 120 ends or bands, exclusive of the waste ends. Hence on a 48-inch card, with 96 ends or slivers, there would be 48 ribbons or bands, and the necessary waste bands on the top-roller, and a like number on the bottom roller, so spaced that the ribbon or band attached to the top roller, if hanging vertically, would be alongside of and parallel with the ribbon or band standing perpendicularly from the bottom roller. Directly in front of these rollers, to which the steel ribbons or bands are attached, is a top and bottom set of leather aprons arranged radially in such a way that the lines where the upper and the lower aprons come in contact is opposite (slightly below it) an imaginary horizontal line on the doffer, where the web is doffed by the comb. The ribbons or bands of steel are passed between the apron rolls at this point, those from the top roller being deflected downwards between the lower set of apron rubs and those from the bottom roller upward between the upper set of apron rubs. When the web is passed between these apron-rolls at their point of contact it is evident that so much of the web as is under the top set of ribbons or bands will be by them carried downward between the leather aprons forming the bottom set of rubs; and so much of the web as is above the bottom ribbons or bands will be carried upward between the leather aprons composing the top set of rubs. The several strips of webs thus separated or divided by the top set of steel ribbons or bands will form the bottom series of ends, while those separated by the bottom set will form the top ends. These several strips or ribbons of film are next rubbed between the aprons and the condensed strands (roving) passed through vibrating guides and wound on the common jack-spools in the usual style. This mode of dividing the film largely increases the number of ends that can be taken from any given surface. For rovings which are more difficult to condense (made out of coarse wool, mungo, shoddy, etc.) an additional amount of rubbing is derived by adding to a single set of radial aprons, another set of horizontal ones for both the top and bottom series of ends.

**Bolette Condenser made with Single Rubbers.**—In Fig. 229, a section of the device as patented by the inventor Mr. Bolette of Pepinster near Verviers, Belgium, in 1884 is given. Letters of reference indicate as follows: *A*, doffer; *B*, doffing comb; *C*, film, (nap or web) for dividing; *D*, automatic apparatus for putting the film in the divider; *E* and *F*, oscillating rollers to which are attached the steel blades *K* and *L*; *G* and *H*, dividing aprons; *I*, *I*, rubbing aprons. The method of operating the machine is as follows: the film *C*, as combed by the doffing comb *B*, from the single doffer cylinder *A*, is introduced by means of the automatic appliance *D*, into or between the carrying and rubbing aprons *G* and *H*. There are also seen two rollers *E* and *F*, to which are attached steel blades *K* and *L*. The free or loose ends of the blades attached to the roller *E*, pass between the aprons *G* and *H*, downwards, and are held firmly against the apron *H*, by the small rollers *J*. The blades attached to the roller *F*, pass between the aprons *G* and *H*, upwards, and are, in like manner, held against the apron *G*, by rollers *J*. The blades of rollers *E* and *F*, therefore, cross each other, and the revolving aprons *G* and *H*, draw or carry the sliver in, at points of intersection, thus dividing it into as many points as there are blades, the several divisions being of the same width as the width of the

blades. The blades run in grooves, and move with the utmost precision, permitting the sliver to be finely divided and producing in this way very fine roving. The two indicating arrows on rollers *E* and *F*, show the direction of oscillation of these rollers which force the blades in and out between the aprons. The backward and forward movement of these blades prevents the accumulation of dirt or grease at the point where they enter between the aprons. There is an appliance not capable of being shown in the sectional view, which is called the side or lateral motion. Its function is to move the rollers *E* and *F*, slowly to and fro in the direction of their length; the object being to so change the point of contact of the blades with the apron, that the latter undergoes but little wear and tear. The

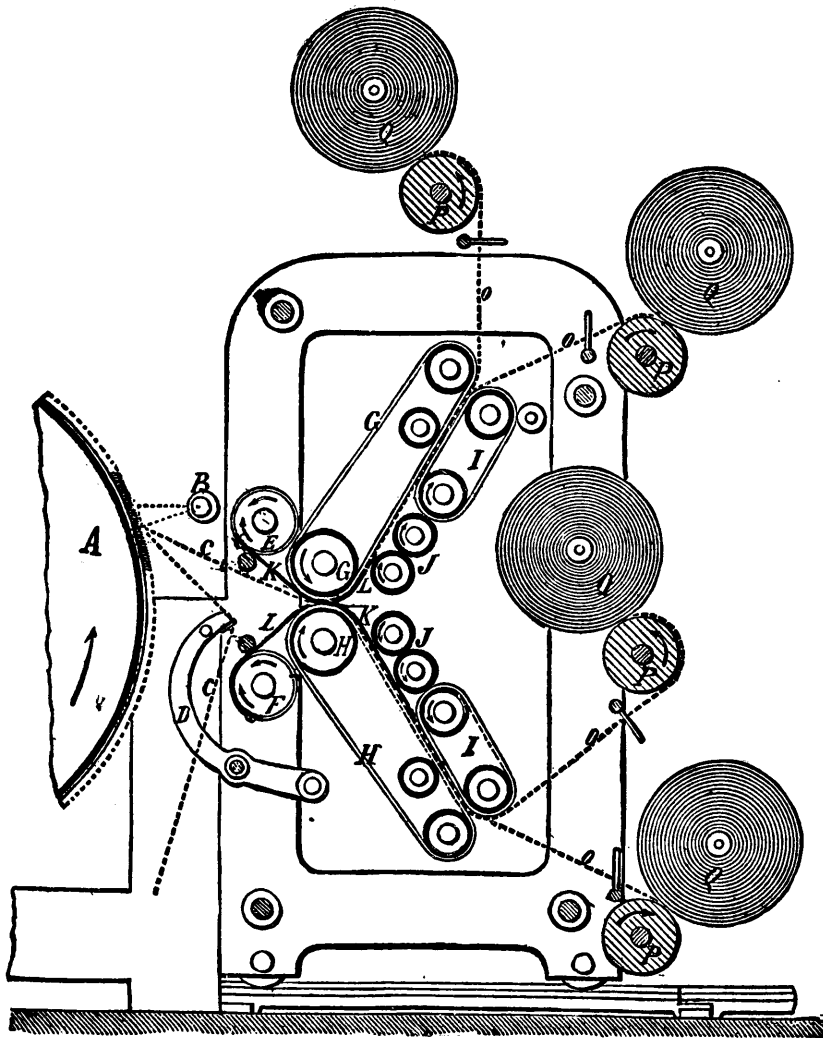


FIG. 229.

rollers *E* and *F*, can be removed and others substituted, having any number of blades, more or less, thus producing a greater or less number of ends. In this way three or four bobbins can be made at will, each having an equal number of ends. Rolls *E* and *F*, draw by the winding up of the steel bands the same between the rubbing aprons and guide rollers *J*, through, and by means of winding off the roller *J*, guide the ribbons towards the condensing attachments *I*. In this manner a steady motion of the steel bands is accomplished. The actual rubbing or condensing of the ribbons is done between *G* and *I*, respectively, and also between *H* and *I*. Aprons *G* and *H*, have only a forward motion whereas aprons *I*, in addition thereto have also a to and fro sideward acting or rubbing motion imparted by eccentrics. After the ribbons of film have been rubbed or condensed into roving strands

they are passed through guides *O*, over rolls *P*, and wound onto jack spools *Q*, which when the proper amount of roving is wound on, are taken out and empty spools put in their places. Another feature greatly in favor of this machine is the saving in card clothing, as the card clothing of the doffer after becoming in time too much worn for the condenser, can be advantageously used for covering the doffer of the first or second breaker.

This Bolette condenser in a short time after coming into the market worked its way into the leading mills in Europe, and is doing so now in this country. The same is especially of great advantage for mills working short stock, as the method of guiding the ribbons is in favor of protecting the same

from breaking, since after the sheet of film on leaving the doffer is cut in its respective ribbons the latter are always supported until condensed in roving.

**Bolette Condenser made with Double Rubbers.**—For such rovings as require an extra amount of rubbing, or those more difficult to condense, Mr. Bolette invented the double rubbing principle as shown in diagram Fig. 230. This double rubbing action he obtained by cutting in two the large aprons *G* and *H*, as shown in his first machine (Fig. 229) and making one half to vibrate, thus giving four vibrating or rubbing aprons (see *I*), in place of only two as formerly used, thus increasing in proportion the amount of rubbing, besides making more even work.

Another item of the working of the condenser is indicated in this section by letters *M* and *N*; the same represents the distance traveled by the blade; *i. e.*, while the blades attached to roller *F*, are coiled or wound up, their ends just reaching to *M*, on apron *G*, the blades attached to roller *E*, are uncoiled to their full length, reaching to *M*, on apron *H*. (This working of the blades also refers to the previous illustration, Fig. 229, but in which letters of reference have been omitted.) A perspective view of the original Bolette condenser, (corresponding to section Fig. 229) is given in Fig. 231, which shows the side of the machine as placed toward the carding engine and illustrates the dividing blades and the side of the machine on which the eccentrics are driven.

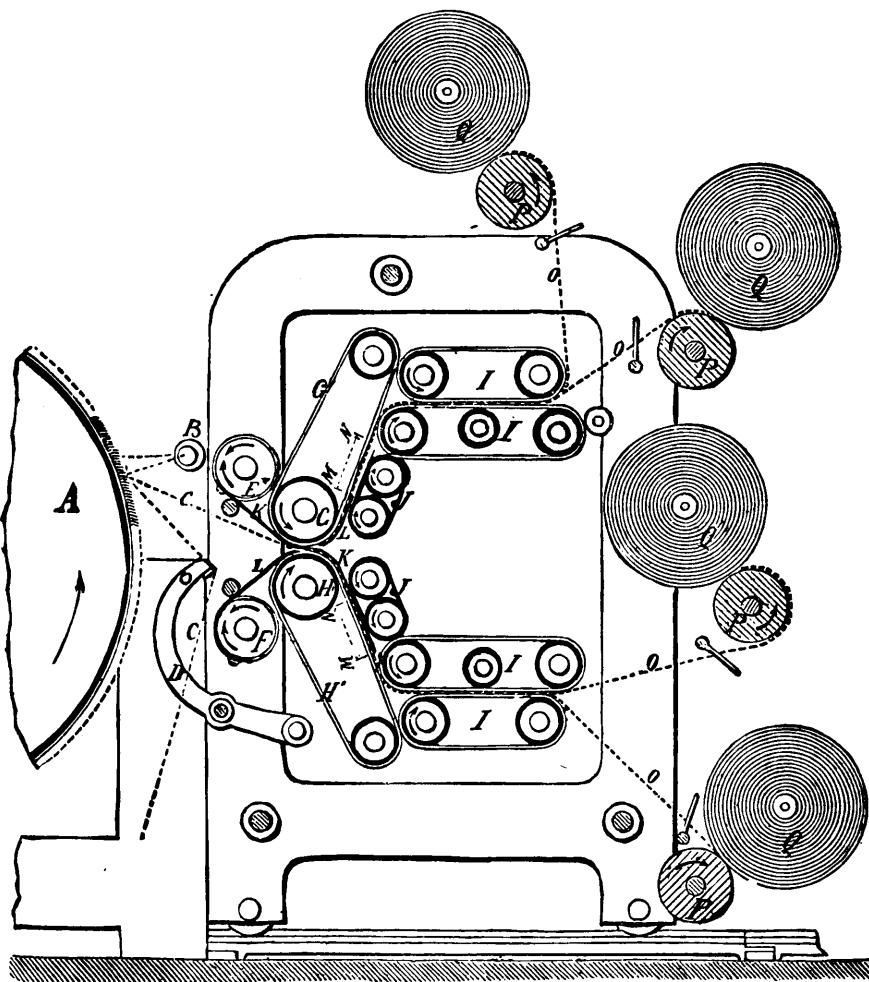


FIG. 230.

**Improved Bolette Condenser.**—The latest improved form of the Bolette Condenser is given in its perspective view in Fig. 232, and in its section in Fig. 233. Letters of reference in Fig. 233 indicate as follows: *A*, doffer; *B*, doffing comb; *C*, sliver (nap) for dividing; *E* and *F*, oscillating rolls to which are attached the steel blades *K* and *L*; *I* and *I*, dividing aprons; *J* and *J*, rolls for keeping blades against dividing aprons; *G* and *G*, rubbing aprons.

Amongst the improvements we find the new patent device for vibrating the blades; *i. e.*, an appliance for giving the blades a backward and forward movement and side motion at the same time, as follows: The two indicating arrows on rollers *E* and *F*, (Fig. 233) show the direction of oscillation of these rollers, which force the blades in and out between the aprons. The backward and

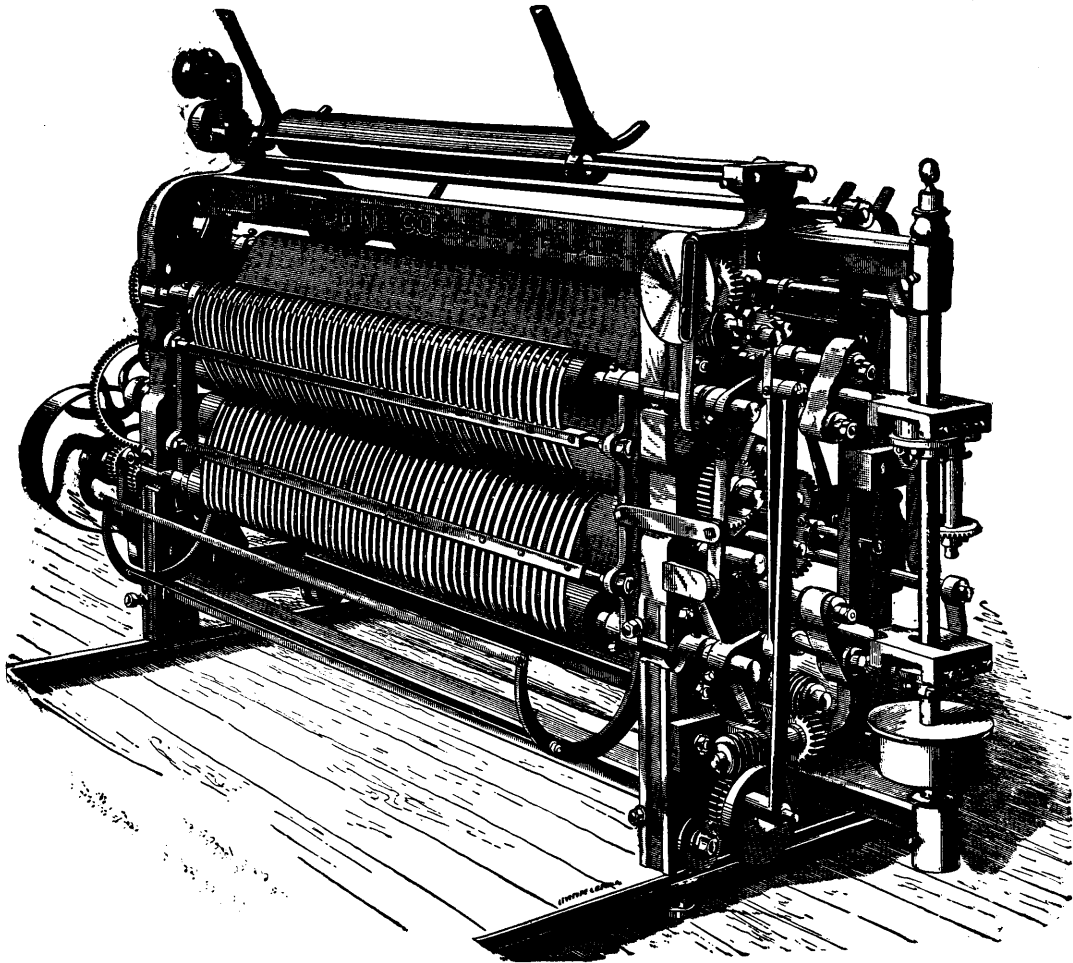


FIG. 231.

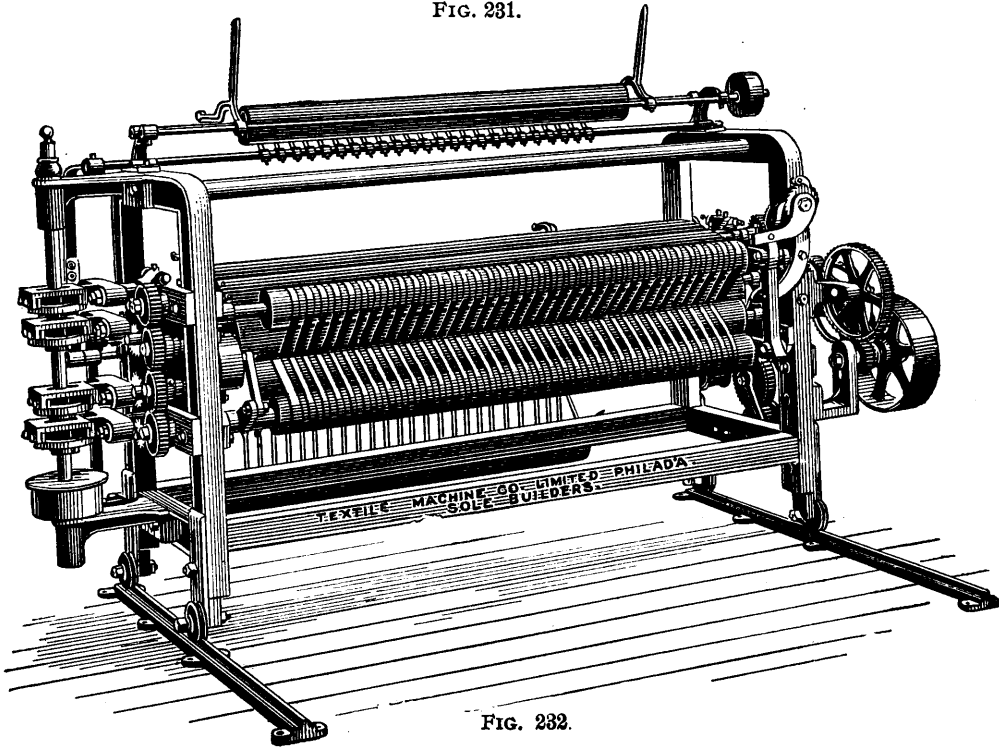


FIG. 232.

forward movement of these blades prevents the accumulation of dirt or grease at the point where they enter between the aprons. The distance traveled by the blades is indicated by the letters *M* and *N*.

It will be observed that while the blades attached to roller *F*, are coiled or wound up, their ends just reaching to *M*, the blades attached to roller *E*, are uncoiled to their full length, reaching to *M*, on apron *I*.

There is an appliance, not capable of being shown in the sectional view, which is called the side or lateral motion. Its function is to move the rollers *E* and *F*, slowly to and fro in the direction of their length; the object being to so change the point of contact of the blades with the apron, that the latter undergoes but little wear and tear.

The eccentric in this improved Bolette Condenser is of such a construction to permit greater speed, thus giving all the rubbing required for any grade of stock. Compared as to size and construction the new condenser is much smaller, less complicated and more readily handled.

**Grinding.**—After covering any roller or cylinder of a carding engine with card-clothing, the latter must be ground so as to take out the inequalities left, even after the most careful covering, as well as to produce the sharp points to the wires as required for good carding.

Two different automatic methods are in use for grinding:

1st. Grinding with a *grinding-roller* about eight to nine inches in diameter, covered with coarse emery and extending across the face of the cylinders or rollers. This grinding-roller also receives a short lateral traverse motion so as to prevent as much as possible the forming of a flat point to the wire which is technically known as chisel-point.

2d. Grinding with a *Traverse Emery Wheel Card-Grinder*. In this device the grinding is done by means of a small drum or pulley covered with emery, which is made to traverse to and fro across the card-clothing surface by means of a double threaded screw placed inside the hollow shaft on which the wheel rotates. For grinding swift and doffer, either kind of grinding device is taken to the carding-engine and the process takes place there, whereas workers and strippers are taken to a card-grinder, as shown in its perspective view in Figs. 234 and 235. The fancy is also taken to the card-grinder, but for the purpose of having the sharp point, formed by itself during carding, taken out. Fig. 234 illustrates the method of using a large grinding-roller (the machine illustrating a card-grinder and turning-lathe combined). Fig. 235 is an illustration of a card-grinder fitted out with a traverse emery wheel.

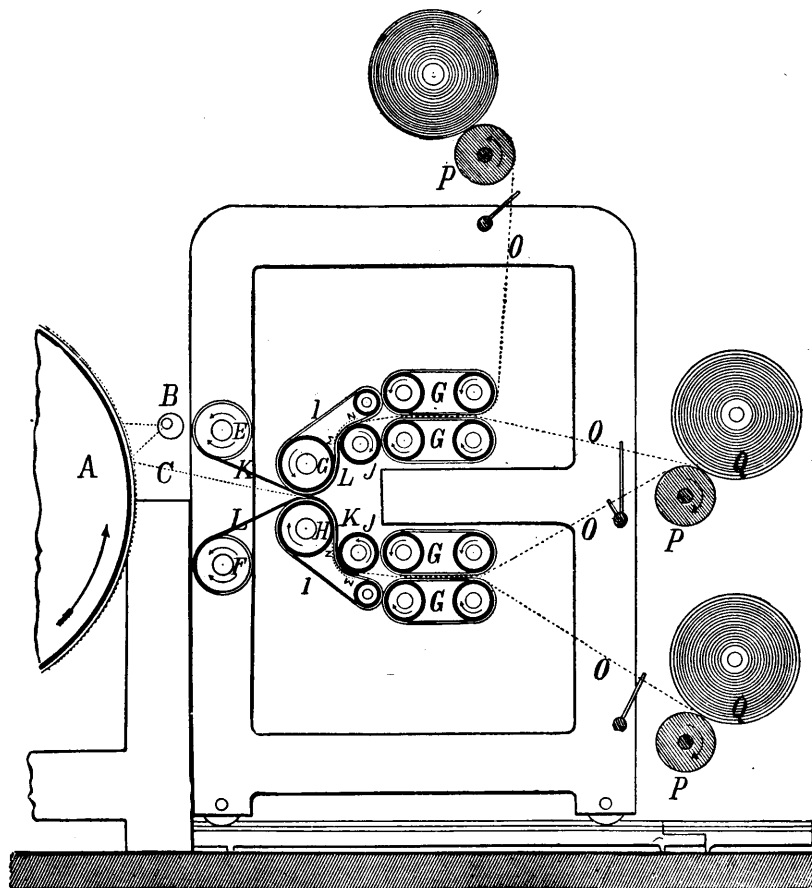


FIG. 233

This machine is arranged for grinding four rollers (workers, strippers, lickers-in etc.) at one time, but it is also built in styles to grind two, and also to grind six rollers at the same time.

After the newly covered clothing has been once ground it will keep itself sharp for a long while, the fancy for example, only needs grinding once, and thereafter keeps itself sharp by the action of the

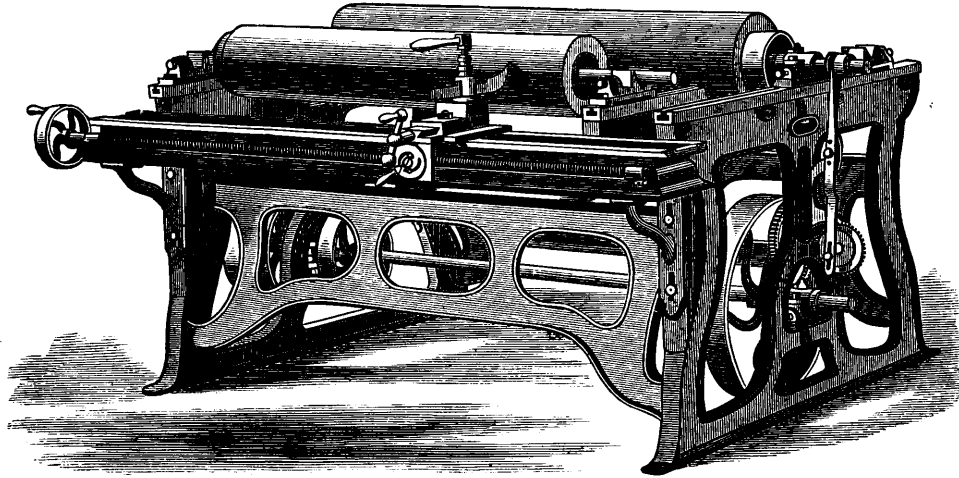


FIG. 234.

swift, in fact the fancy will get too sharp by this action and needs occasionally to be taken to the card-grinder to have this sharp point taken off. The action of the fancy will also assist, to a smaller extent, to keep the swift sharp and thus the latter only occasionally needs very little grinding. The workers

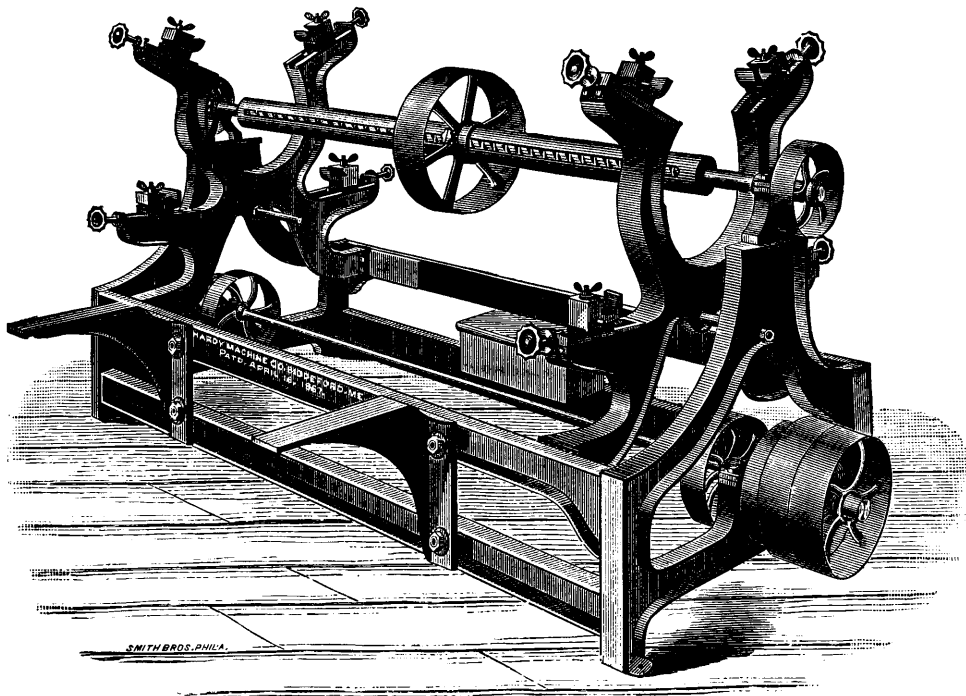


FIG. 235.

will keep themselves more or less sharp by the action of the strippers, and the latter vice-versa. The doffer will also be injured by too much grinding, since it will keep sharp by the action of the *tickler* or *dickey* as sometimes called.

The plan observed by carders who object to grinding after the first time, is to simply hold a

piece of emery cloth stretched on a wooden frame to the rollers about once a week, or in a fortnight, so as to throw out any dust or dirt from amongst the teeth; this operation will also give some polish to the points of the card clothing. Such carders as insist on carding generally do this work once in every two months, or thereabouts.

**Turning and Covering Rollers.**—This procedure refers especially to the use of wooden rollers, since those made of iron will be always true. If a wooden roller requires re-covering, the same is turned off so as to make sure of being level. The process of turning a roller is very simple, and is performed on a turning lathe, of which an illustration (card-grinder and turning-lathe combined) is given in Fig. 234, and which will readily explain the *modus operandi*.

**Preparing Waste for Re-working.**—The process of re-working the different waste in a woolen mill also comes under the head of carding. All the waste made in a mill can be classified either under *hard waste* or *soft waste*.

**Hard Waste.**—Under this name we may classify headings as separated from the finished cloth before making the same ready for the market, old samples, woven waste made in the weave room by starting warps, hard twisted or double and twist yarn waste made in the weaving or spinning department, etc.

**Soft Waste.**—Thus we classify such yarn waste as has received only a little twist, also roving and card-waste, etc.

We do not wish to say by this that all the waste in a woolen mill shall be graded in these two divisions and worked up by two rules, for the practical superintendent will grade his waste with equal care as he does his different wools, and make several divisions of each, since if carefully and knowingly treated, waste will take the place of wool in a minor quality. Speaking about hard waste, for example, headings, he will keep such as have been heavily felted from slightly fulled flannels, or such as came from the weave room. Again, he will keep double and twist yarn waste apart from single yarn waste, also filling yarn waste apart from roving waste, etc., since each waste requires its own method of preparation. Headings, also hard-twisted yarn waste, coming from the mill in balls, bunches, strings, knots, etc., are first roughly cut up by means of a hatchet and then submitted to the action of a Rag or Shoddy Picker. Some kinds may require only one run; others two, before they can be submitted to the action of the Garnett machine. Short, hard waste, and all soft waste, can go directly on the latter machine; whereas card waste, dirty roving waste, is subjected only to the action of a Waste Duster. Clean roving waste may be mixed directly in a duplicate lot.

**Rag or Shoddy Picker.**—An illustration of this machine is given in Fig 236. The same consists of feed-apron, feed-rollers, cylinder and trunk for conducting the shoddy out of the machine. The cylinder which is the main feature of the machine is strongly built and runs in brass bottom steps. The average length of it is 31 inches from point of teeth,  $19\frac{3}{4}$  inches wide, and  $16\frac{1}{2}$  inches on face of teeth. They are made with middle casting of solid iron, with double flanges, the lags being bolted on alternately, bringing each bolt through opposite side of flanges; by this means the bolts are not all in the same circle, thus presenting as near as possible a full surface of teeth, besides making the cylinder much stronger. The teeth are made from best English steel, evenly hardened and tempered, and put in the wood in such a manner that it is very rare for one to come out, lag or split. For pulling of ordinary sorted soft woolen rags the cylinder generally contains 10,000 teeth, made from number 10 steel, and for sorted hard woolen rags, 12,000 or 13,000 teeth of number 11 steel. The teeth are  $2\frac{1}{4}$  inches long; top lags are  $1\frac{1}{4}$  inches thick; teeth stand out 1 inch. The rags to be picked are placed in the feed-apron, which in turn forwards the same to the feed-rolls. On emerging from them they are seized by the teeth of the cylinder, which not only separates thread from thread but actually tears fibre from fibre, reducing the rags to a flossy wool-like state. As the rags are ground up, the material is forced (blown)

down and out the trunk, finding exit from the machine to the stock house (a house built at the back to hold the stock and connected with the picker below the feed table by previously-mentioned trunk) Any hard fragments not well picked fall into a cage from which they are taken and replaced on the feed-apron.

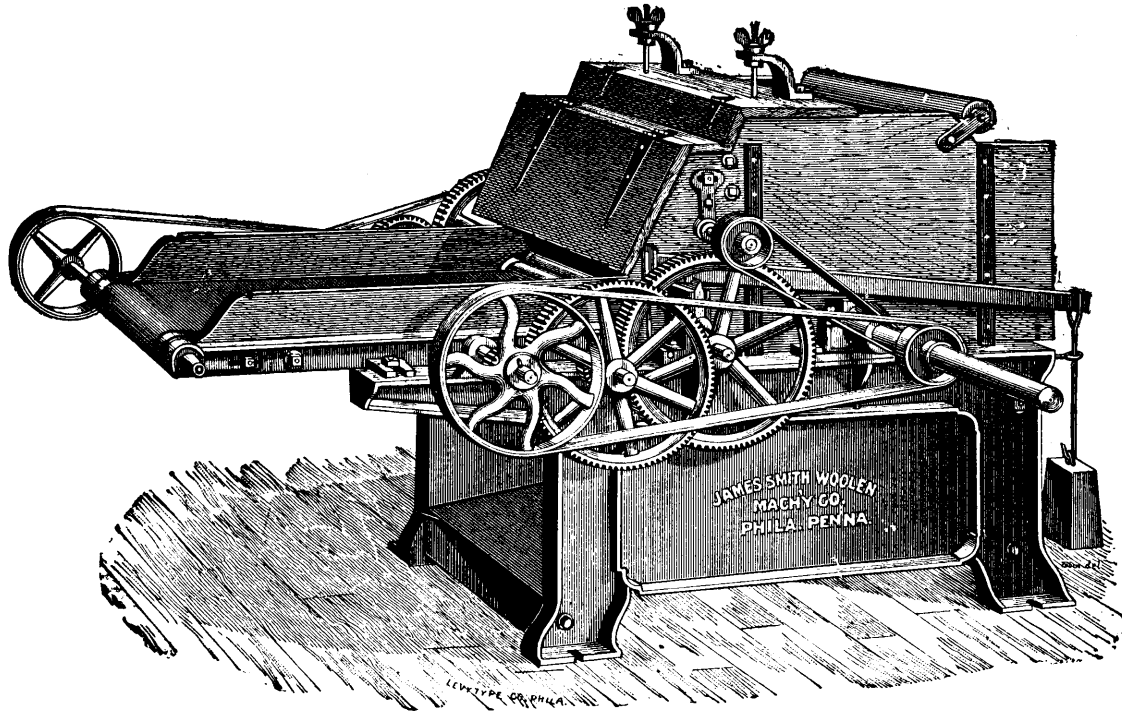


FIG. 236

**Garnett Machine.**—This is a machine the use of which is of comparatively recent origin. It is only within the past few years that such a machine has been introduced to the notice of manufacturers, and yet so great is its merit that within a short space of time the Garnett machine has become an indispensable adjunct to many mills. It enables manufacturers to comb out all their waste, whether from cards, mules, spinning frames, or from whatever source twisted or tangled fibres are produced in

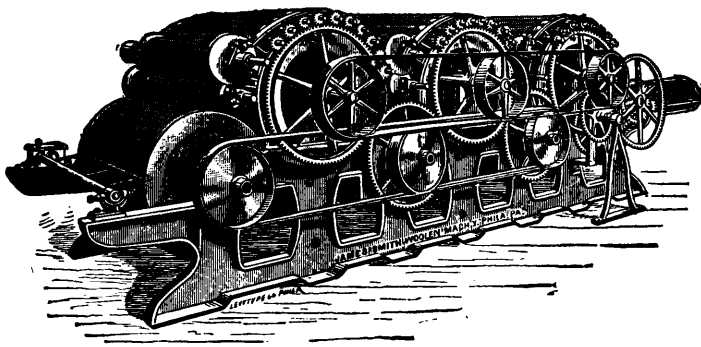


FIG. 237.

the various processes of manufacture, as well as of the pieces, clippings, or remains of the manufactured product (after being picked on the shoddy picker) and to restore it to the original fibre. This is a great saving, as otherwise such waste would be disposed of at a nominal sum. In many cases a special branch of industry has been originated by parties who make a business of buying wastes of various kinds, and after reducing the same in their Garnett machines re-sell at great profit. These machines in principle are carding engines, constructed in a compact form. The cylinders and workers are clothed with strong, sharp-pointed steel teeth, so adjusted as to work on the twist of the yarn or thread and gradually comb or tease it out and hold the fibres together. This gradual untwisting preserves the fibres of the wool in nearly their original length of staple. In the profitable working of waste it is advisable not to let it accumulate. That which is made one day should be carded the next, for if it



be allowed to remain much longer the oil in the same will soon become gummy and will set the twist so firmly that the waste is much harder to comb out, and thus the stock is deteriorated in the carding process. On the contrary, if the waste be worked before the oil sets the twist, the natural spring of the wool, which thus is preserved, assists in opening it out, and the waste or fabric is much more easily reduced to wool again. This point cannot be too carefully noted by parties who work up, or desire to work up, their own waste. Garnett machines are built either as one, two, or three main cylinder machines, either with breast or plain, and from thirty to sixty inches in width. Over each main cylinder are placed the self-stripping workers, and a fancy with stripper. Unlike the fancy of the wool card, on this machine the fancy does as much carding as the workers; it combs the stock across the teeth of the stripper when it raises it from the main cylinder, the stripper revolving slowly lays the stock again on the main cylinder that it may be lashed against the doffer. The three cylinder machine, see Fig. 237, is the most practical and will perfectly reduce to its original fibre the finest twisted and double yarn waste, cop waste, and all kinds of clippings from goods, doing from 300 to 800 pounds per day. A two cylinder machine will work all kinds of soft woolen, common worsted and other yarn wastes, in quantities about like the three cylinder. The one cylinder machine will thoroughly open soft waste in once passing through, and is especially adapted to small mills. All the machines have the same attachments and are alike except in length. As previously mentioned, all machines are either breast or plain. In the plain machine the licker-in runs downward against the feed-rolls and is stripped by the main cylinder. In the breast machine the licker-in runs up against feed-rolls and is stripped by a tumbler, which transfers the stock to the main cylinder. In this machine the licker-in is provided with five toothed rolls called breast workers. The stock being fed in by the feed-rolls is caught up by the licker-in and subject to seven carding points before reaching the main cylinder. The breast machine is best adapted to lumpy, hard-twisted, or tangled stock, as the stock being subject to carding against the workers is much more opened when it reaches the main cylinder than in the plain machine. The plain machine is usually built with an eight-inch worker or lumper-roll between licker-in and main cylinder. This worker is very useful on some kinds of lumpy stock in breaking up the lumps before they reach the main cylinder. The worker is geared to run very slowly, so as to hold the lumps as long as possible while being combed out by the licker-in. In comparing the breast with the plain machine, it should be said in general, that the breast machine is best adapted to every condition where the

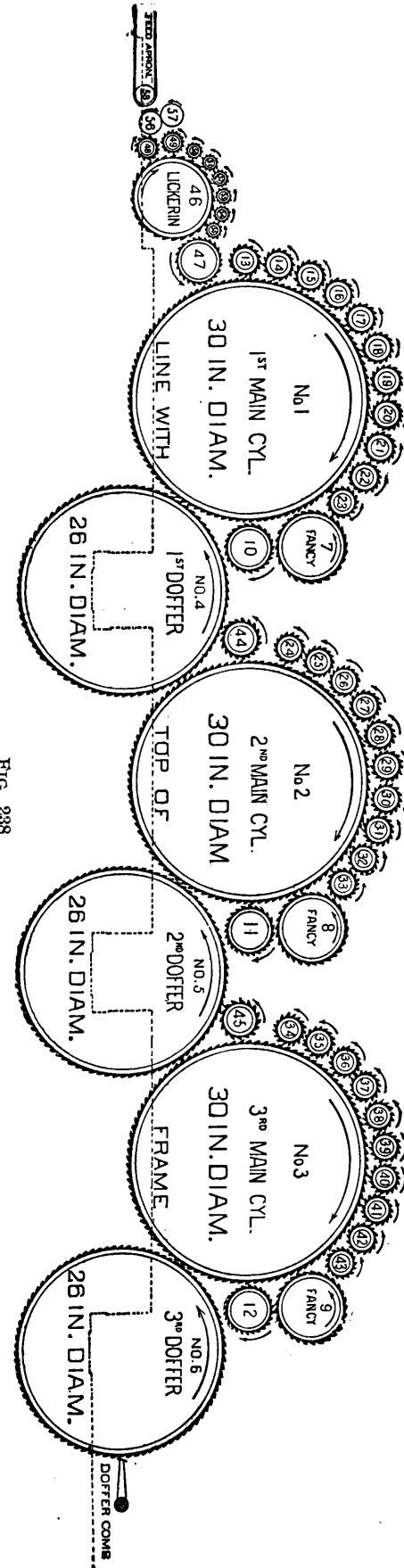


Fig. 238.

stock contains firmly twisted threads, lumps or pieces that would injure the more delicate clothing of the main cylinder. But where soft yarn and waste only is to be carded, then the breast is not required. The doffers and workers are driven independently so that their speed can be changed to suit the stock to be worked, as waste that is twisted very hard requires to remain in the machine much longer than soft waste. Fig. 238 illustrates in section the three-cylinder machine with breast. All details necessary for an explanation are indicated in the illustration. Garnett machines and carding engines (Breaker-card) are also frequently combined in one machine. The Retainer-roll, explained on pages 128 and 129, and illustrated in Fig. 216, is also frequently added to Garnett machines.

**Waste Duster.**—This is another machine used in connection with previously explained machines

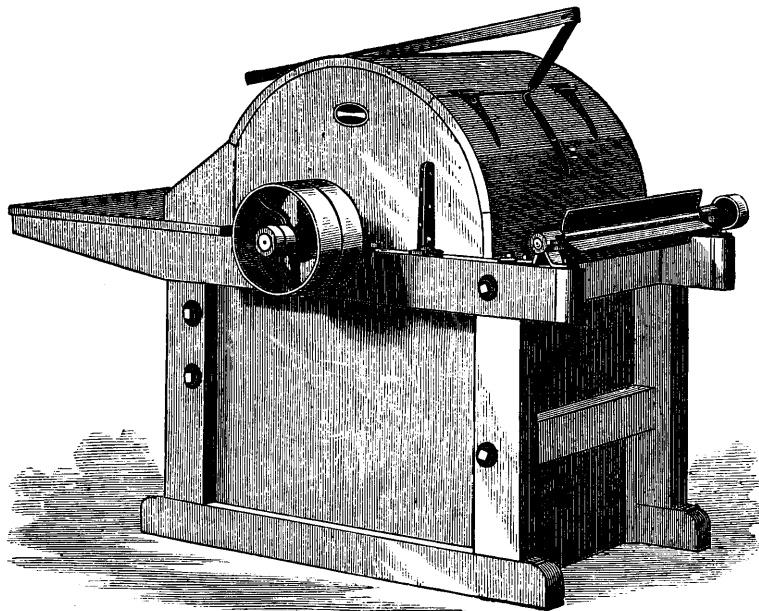


FIG. 239.

in the waste-preparing departments of woolen mills. The machine illustrated in Fig. 239 refers more particularly to a duster for soft waste, as card waste, etc., and in its principle of working closely resembles the wool duster, explained in a previous chapter. For the dusting of rags before picking, a larger size of machine (also having a blower and dust trunk on its top) is used. It is very important to have the rags properly dusted before picking the same, since if not cleaned they fill the room with dust when picking, wear out the teeth of the picker faster, injure the appearance of the shoddy, and clog up the card wire in carding. Also in oiling, the

rags that have been properly dusted requires less oil.

**Spinning.**—The object of spinning consists in transforming the roving produced on the finisher-card by means of drawing out and twisting into a thread of required counts and strength.

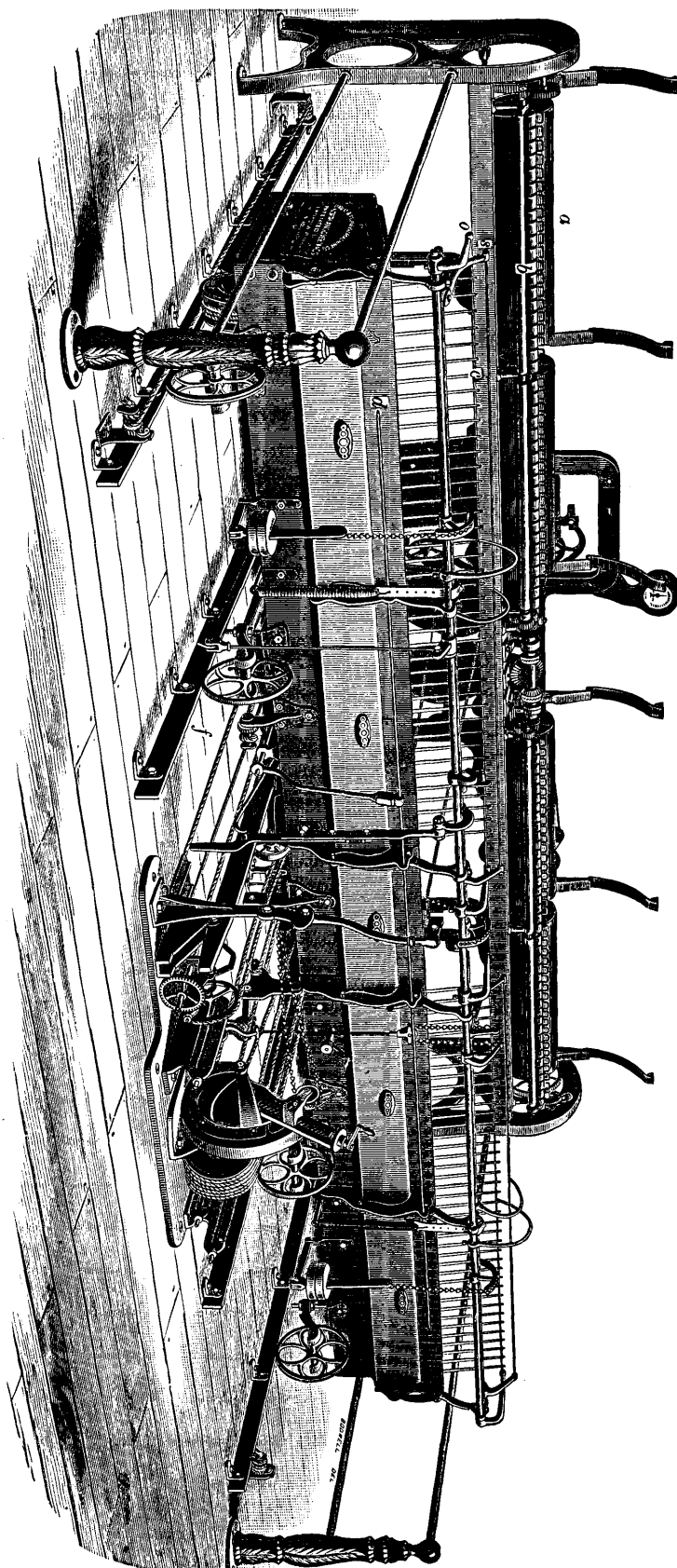
Some historians claim Leonardo da Vinci as the inventor of the characteristic spindle required for spinning, but if so, his idea or device as (claimed) constructed in 1452 was never universally known. Spinning was carried on in its crudest state until in 1530 a German by the name of Johann Jürgen, of Wolfenbüttel, invented the well-known spin-wheel. The same has been by accident, or fortune we might more properly say, the means for the invention of the *Jenny* by the weaver Hargreaves, of Blackburn, England, in 1767. He was watching his daughter Jenny operate the spinning-wheel when it accidentally fell over and he noticed the continuous turning (for a short time) of the thus vertically-standing spindle. In 1769 the great genius Arkwright received a patent on a device which laid the foundation for our present cotton spinning; *i. e.*, drawing out the sliver by means of three sets of rolls and winding the same upon the bobbin situated on the spindle and between the flyer. The inventions of Hargreaves and Arkwright were successfully combined by Crompton who, about 1775, invented the *Mule-Jenny*.

**Modern Spinning Machinery.**—Spinning at present is carried on either on the mule or the spinning machine.

**Mule.**—This is one of the most intricate and complicated machines used in a woolen mill. For illustrating our explanations of the working of this machine, Figs. 240 to 243 are given. Fig. 240

illustrates the front view of the mule as built by the Davis & Furber Machine Company. Fig. 241 shows the rear view of the same machine. Fig. 242 represents the right hand side view of the mule as built by the James Smith Woolen Machinery Company. Fig. 243 illustrates the Bancroft Improved Woolen Mule. Fig. 240 has been marked with letters of reference to which we will refer in our explanations as to construction and operation of this machine. The roving leaves the finisher card wrapped upon long spools (see Fig. 219) which are forwarded to the spinning department and there set on the upright stands *a*, at the back of the mule (shown empty in our illustration). In front of the same are the *delivery rollers* through which the roving ends when unwinding from the spools pass, in front of these rollers is the *carriage d*, containing the *spindles c*, and to which the corresponding roving ends are fastened. Some mills spin directly on the bare spindles, others use paper or tin tubes, whereas others (being the style mostly used) employ wooden bobbins. The modus operandi for imparting the twist into the sliver is thus: A large tin drum runs the entire length of the inside frame work of the carriage which receives motion by wheel and other gearing from the head stock. Round the drum and also around each spindle is wrapped the spindle band, which thus transfers the motion from the drum to the spindle when the former is in motion. Illustrations and more detailed explanations on this subject (as well as the method of running spindle bands) have been given on this subject in the chapter on cotton spinning, to which the reader is referred.

The principle of the working of the mule is as follows: The carriage



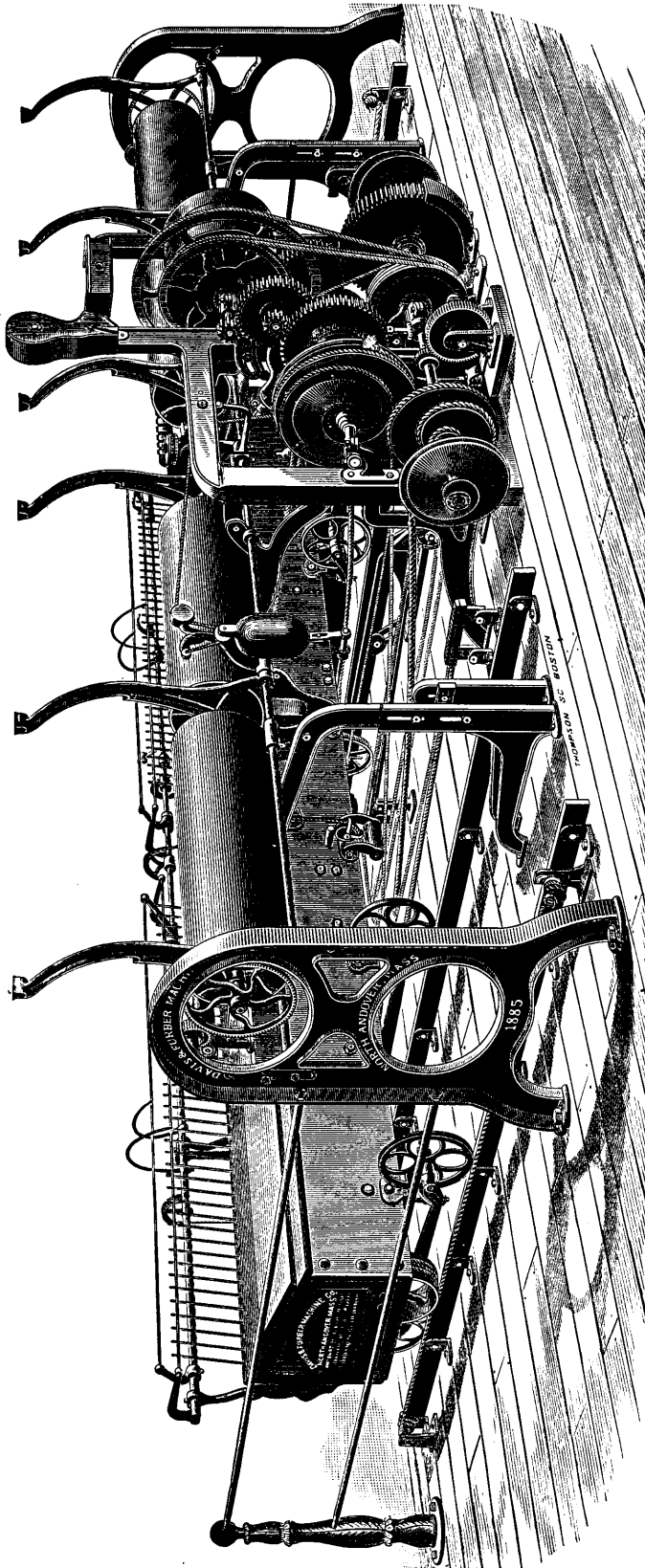


FIG. 241.

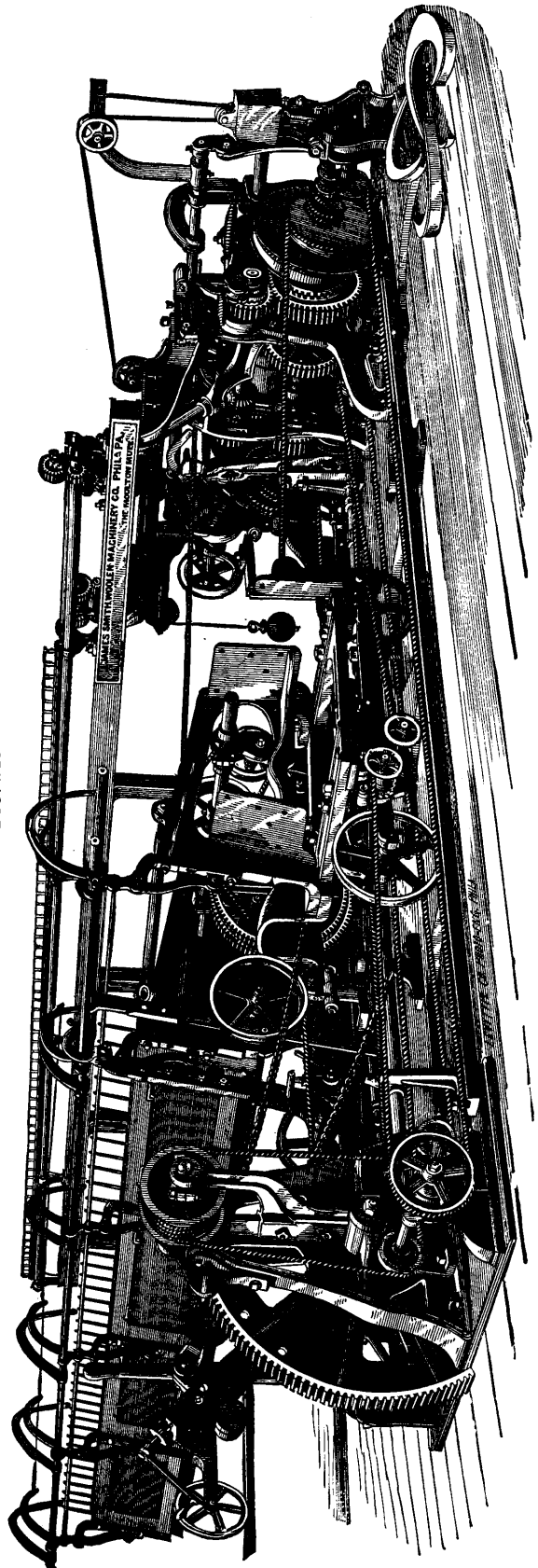


FIG. 242.

*d*, with the spindles *c*, to which the roving is fastened, is at the beginning, close up to the rollers *b*. As soon as the latter begin to revolve (*i. e.*, deliver roving) the carriage starts simultaneously to *run out* on the rails *f*, and at a corresponding speed to keep the roving nicely taut, but imparting no stretching. The spindles also commence to turn, thus putting some twist in the roving. When the carriage has run out about a yard or so (this is the usual course for medium and fine counts; *i. e.*, to deliver roving during one-half the time of running out of the carriage; but for heavy counts of yarns the rollers are made to deliver during two-thirds, or about that time) the delivery rollers stop, but the carriage continues on its outward run. The spindles also continue to revolve. This will draw out the roving, and the yard or so of roving delivered will get elongated to about two yards, besides twist put in at the same time by the action of the spindles. When the carriage has been completely run out, the spindles are made to revolve at a greatly increased rate of speed, so as to save time. During the twisting, the threads are held slightly above the tops of the spindles by what is called the *faller*, *s*, to prevent the yarn from being wound up.

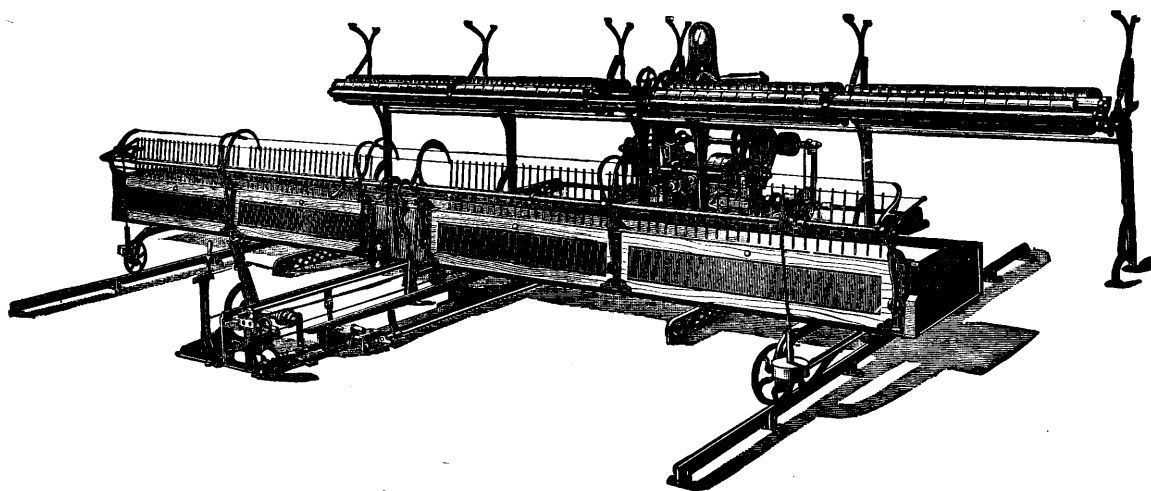


FIG. 243.

When the required amount of twist has been introduced in the yarn, the carriage *d*, returns slowly a few inches, and the spindles also make a few turns backward to undo the extra twist imparted to the yarn nearest the point of the spindle, also to unwind these few inches, as being wrapped too high on the spindle, and which must be re-wound with the stretch of new yarn (2 yards) just spun. After the spindles reversed themselves a few turns, the *faller* *s*, and *counter-faller* *o*, exchange positions, being lowered to keep this unwound yarn straight, and then the carriage commences to run in (towards the rollers), and the spindles wind on the yarn in its proper place on the cop or bobbin, as regulated by the counter-faller *o*. A thorough description, with illustration of building, cop or bobbin, has been given in the cotton chapter, to which the reader is referred. All these motions thus far explained are worked automatically from the headstock of the machine. The draft, *i. e.*, the length of roving to be given out by the delivery rollers, is very easily changed by the operator by simply moving the *setting finger* in a groove on the face of the *slubbing wheel* to the figure required, which is indicated on its face, the position of this finger determining the number of inches turned out by the rollers. A similar simple device, by altering a peg on a wheel, regulates the amount of twist put in after the carriage has stopped. Fig 243 illustrates the improved Bancroft Woolen Mule, the main features of which are a steel Race Shaft instead of a Race Belt, and flexible iron chains instead of ropes, which give strength to the machine where required, and ensure perfect work for any counts of yarn. This mule is also provided with what is known as the new Builder, the improved spindle, with a straight foot and an attachment for running the spindles in either direction *i. e.* for making either right hand or left hand twist without the necessity of changing the bands.

**Spinning Machine.**—This machine is designed to fill the same place in woolen mills that the ring-frame does in cotton mills. An illustration of this spinning machine as built by the Davis & Furber Machine Company is given in Figs. 244 and 245. Both illustrations represent only two

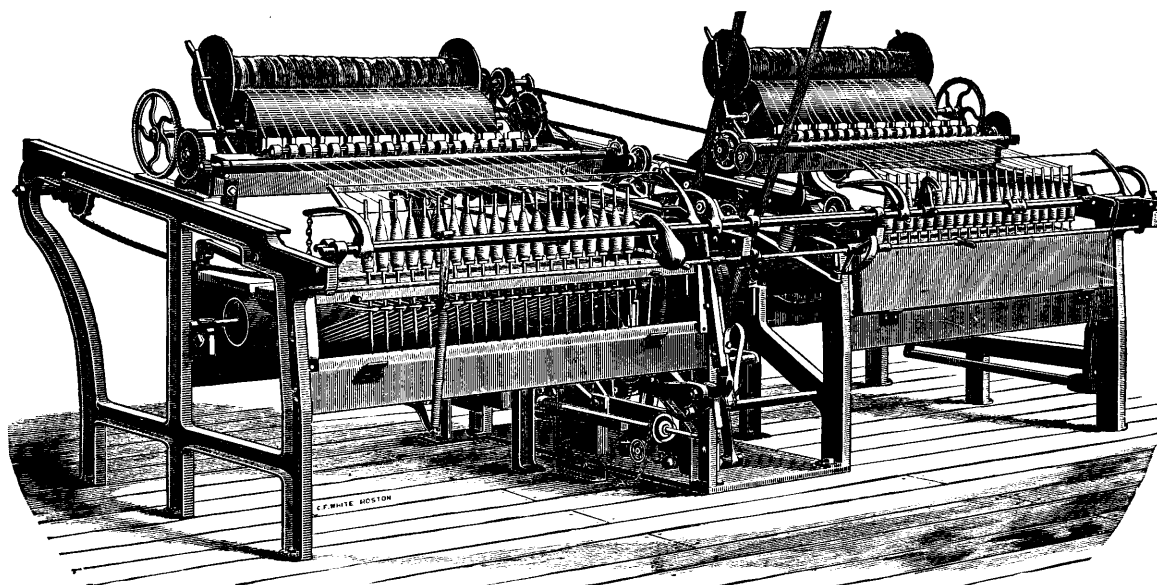


FIG. 244.

sections of the spinning machine which is done in order to bring the cut to a reasonable size for the book. Fig. 244 shows the front view and Fig. 245 the back view of the spinner. The machine is named after the inventor, Mr. Edward Wright, the *Wright Spinner*. The principle and also the object

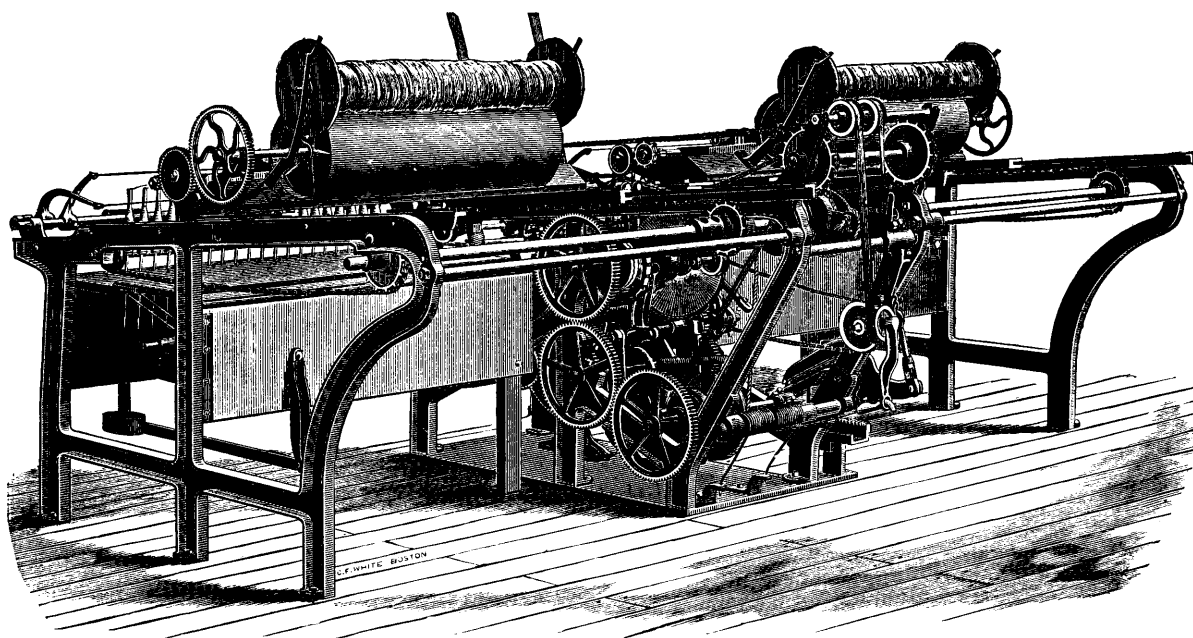


FIG. 245.

of the machine is to occupy the limited floor space of a cotton spinning frame, and yet to preserve the *long stretch* principle characteristic of mule spinning. The spindles in the spinning machine are mounted in a stationary frame, the *stretch* of the roving being obtained by the movement of the roving

rolls, to and from the spindles instead of the reverse as with the mule. The plan embraced in the spinning machine makes the tending of the same a simple matter and less exhaustive compared to the tending of a mule, as the operator has only to walk back and forth in front of the spindles, as in the case of a twister. The floor space required by this spinner is but little more than half that necessary per spindle in mule spinning, while the product is substantially the same on all kinds of work. Another feature in favor of the spinning machine compared to the mule is a saving in power, since the spinner saves the propelling of the heavy carriage back and forth as required with the mule. The spinner is also easier on the yarn, both in drawing the roving, and in the actual twisting process; in the drawing, because the light roving rolls can be handled more deftly by the scrolls than the heavy carriage of a mule, while in twisting, as the distance from the spindle to the rolls is but three feet in this spinner, while it is six feet in the mule, there is only one half the weight of yarn bearing on points of spindles, hence, poor stock can be worked with less breakage on the spinner. Another feature in favor of the spinner compared to a mule is that a harder bobbin can be made, because the process of winding occurs twice as often in the spinner or once in every three feet of length of yarn, hence as yarn is wound on closer, and *tied down* more frequently, it follows that more yarn can be put onto a bobbin before doffing, also there will not be so much trouble from ravelling, in the subsequent operations of spooling and weaving. More perfect yarn can be made with the spinning machine because the distance from spindle to rolls being so short, the yarn does not lop down while twisting but extends in almost a straight line, hence the fibres can take a natural position through the entire distance. Again when the ends break on a common mule the operator must hasten to piece up, because the outward movement of the carriage forces him away, therefore a poor splice often results besides some of the ends may have to be left until another *draw*. With the spinner the tender can generally reach to the broken end and *piece* it while the twist is being put in, hence more perfect yarn results.

**Ring Spinning.**—Experiments have been and are constantly made both here and in Europe, especially the latter place, to adopt the ring spinning machine so extensively used in cotton spinning for the spinning of woolen yarn, but the results thus far derived are not very satisfactory and hardly ever will be, since the roving producing the woolen thread is, on an average, not sufficiently strong to resist the stretch of the ring traveler. No doubt if using only the best of material the question might be more easily solved, but such yarn is only made in very few mills. Most of the manufacturers who insisted upon experimenting in this line, have these ring spinning machines changed into twisters.

**Spinning Machine Attached to Finisher Card.**—This method of spinning has been lately ex-

perimented with in Europe, various patents have been issued in its interest but so far without great results To give an idea of this machine a diagram of such a one as built by O. Shimmel is given in Fig. 246. Letters of reference on the same indicate as follows: *A*, the swift; *B*, the doffer-cylinder; *D*, the doffer-comb; *C*, the condenser-rolls; *K*, the spindle; *G*, the flyer; *E*, the whirl for turning the flyer; *L*, the whirl for turning the spindle; *H*, the bobbin; *F, F*, rest for holding the flyer; *I, I*, movable carriage. The machine is only used for spinning heavy counts of yarn from  $\frac{1}{2}$ -run to  $\frac{3}{4}$ -run.

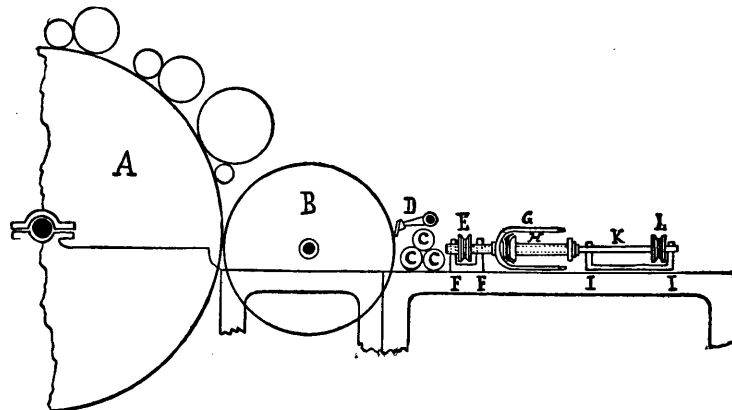


FIG. 246.

**Single Yarn.**—After the yarn has been spun and the bobbins or cops taken from the spindle (doffed) the same is ready for the weaving department.

**Warp Yarn** is wound on the *spooler* on large spools (from twenty-five to fifty more or less ends on each). An illustration of the same is given in Fig. 247. *A*, the bobbin stand, for holding the bobbins (or cops); the ends of the latter are passed through guides *B*, as situated vertically above the bobbins from these guides they are passed (running horizontally) to the guides *C*, of the spooling frame, and, from there through the vibrating guides *D* and *E*, onto the large spool (dresser spool) *F*, to which motion is imparted by drum *G*, driven by pulley *H*. A novel feature of this spooler is the arrangement

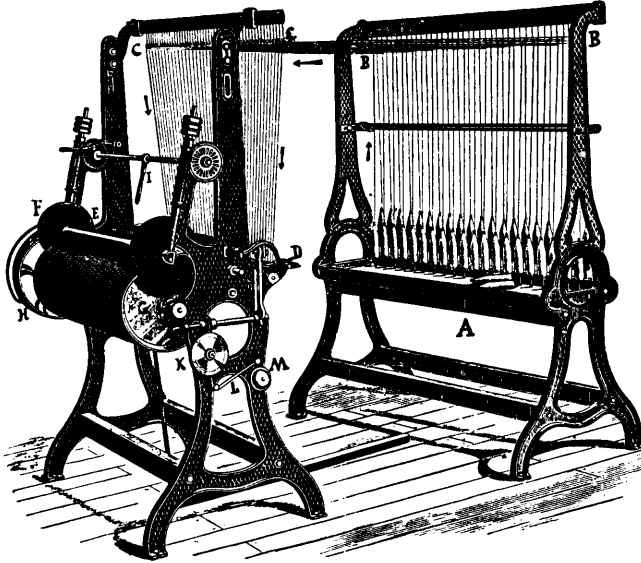


FIG. 247.

for holding the spool *F*, which does away with the old hanging weights. By means of lever *I*, the spool when filled can be quickly raised from the drum, where held by a dog, the filled spool removed, an empty one substituted and lowered upon the drum, and the process of filling a new spool immediately commenced again. The vibrating arrangement of this machine is such that both guides *D*, and *E*, are simultaneously vibrated in the same direction, which avoids creasing the yarn rollers, and also prevents any undue strain of the threads; this vibrating rigging can be adjusted to give any desired length of traverse. *K*, wheel for indicating amount of yarn wound on spool; the same operates on lever *L*, which strikes on bell *M*, when a certain amount of yarn is wound. The spools as made on this spooler are then forwarded to the dresser.

**Filling Yarn** as spun on the spinning machine is ready for the loom when being doffed, *i. e.*, taken from the spindles.

**Twisting.**—The operation of transforming two, three, or more threads of single yarn into one thread is known as twisting. The same is generally done on the *Ring-twister*, of which a specimen is

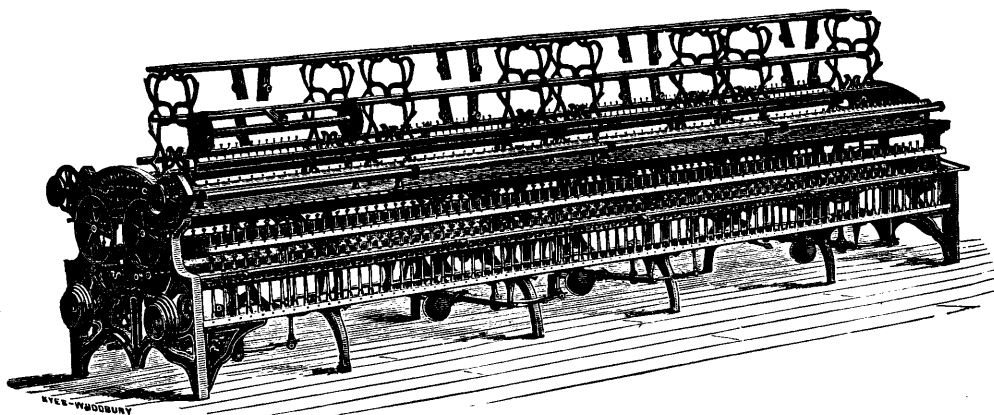


FIG. 248.

shown in Fig. 248; or it can also be done on the mule or spinning machine previously illustrated. In either machine it closely resembles the operation of twisting cotton yarns, as explained in the chapter, on these yarns. Two methods of preparing single yarn for twisting are in use; either the yarns are wound on large spools (on a spooler, as shown in Fig. 247, and previously explained), or the bobbins containing the single yarn are put in a creel on the twister and the yarn twisted direct. The first-mentioned



method is more frequently used, whereas the latter is used in dealing with small lots. If winding the yarn on large spools, and using the same in the twister, there is less risk of single ends being allowed to run, hence waste being made in pulling the same off, besides the operator can mind a greater number of spindles. In opposition to this, the method of using bobbins direct from a creel will not ruffle the fibre; besides it is claimed that the twist will lay better if thus twisting the yarn the reverse way from that in which it is wound on the spindle during the winding operation in the spinning process.

The direction of putting in twist on a twister must be always the reverse from the twist the single yarn contains. This twisting will actually take out some of the twist from the minor yarns. Yarns will always lose in length by twisting two or more ends together, and this in proportion to the counts of the minor yarn as well as the amount of twist required to be put in, hence the percentage of loss in twisting will vary with each lot.

**Ring-Twister.**—An illustration of this machine is given in Fig. 248, and which is built either with single or double cylinders (drums). The *double-cylinder twisters* (being the style shown in our illustration) are arranged with two clock motions, so that each side of the machine runs independently of the other, and when one side is stopped the other side can be kept running.

**Two-fold Yarn.**—For some fabrics a two (or sometimes a three or more) fold yarn is required; for example, for face filling for chinchillas or single overcoating fabrics. For such yarns the minor threads are wound on a large spool on the spooler, as illustrated in Fig. 247, and from there unwound

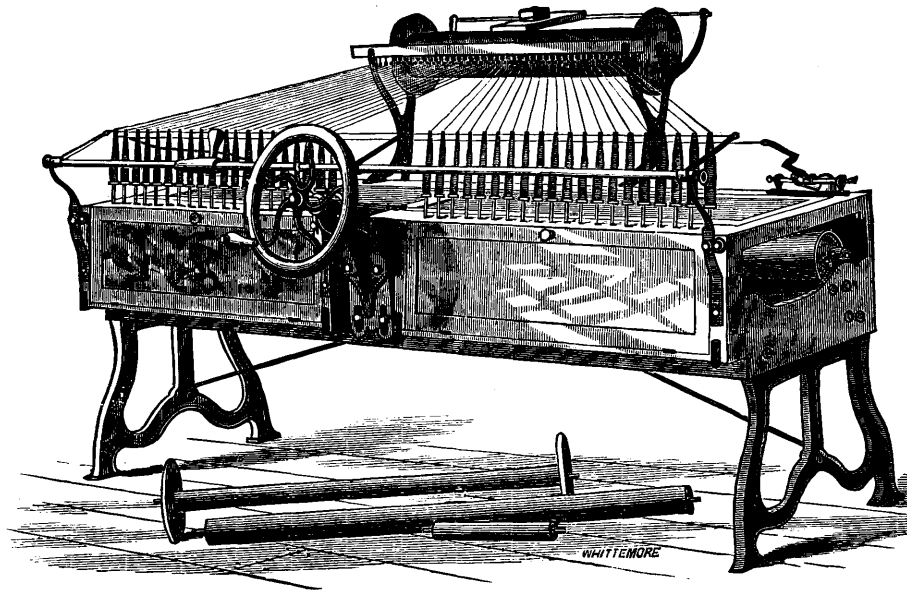


FIG. 249.

on the *bobbin-winder*, of which an illustration is given in Fig. 249. During the unwinding two (or more) ends run together through the same guide and onto the same bobbin.



## Worsted.

There was a time when wools were simply divided into two divisions; short and long wools, or as they were then technically known *Clothing* and *Combing* wools. No doubt in those times, such a classification may have been more or less correct, but this is not the case at present, since our modern worsted machinery works a short stapled as well as a long stapled wool, and our modern woolen machinery permits the use of such wools as in former times would have been considered too long.

The principle of manufacturing a worsted thread is to spin a thread from wool with the fibres composing the same placed smoothly in the direction of the thread and parallel to each other (the same as in combed cotton yarn), whereas in woolen yarn we find that the fibres composing the thread are placed in every direction crossing and overlapping each other constantly, so as to produce a fur-like surface caused by the ends extending more or less outside the body of the thread. To illustrate this subject Figs. 250 and 251 are given. Fig. 250 illustrates a worsted thread (magnified) made of long stapled and strong fibres; Fig. 251 shows a worsted thread similarly magnified, made of fine and short stapled wool. In both illustrations the fibres composing the thread are seen to rest more or less parallel, and this will be much more noticeable if comparing them to a similar illustration of a woolen thread given in Fig. 189, page 118 in the previous chapter on the manufacture of woolen yarns.



FIG. 250.



FIG 251.

There is one feature found in wool fibres, which to a great extent classifies them as more or less adapted for wool spinning or for worsted spinning, which is their felting or non-felting properties, since wool with marked felting qualities is better adapted for the manufacture of woolen yarn, whereas wool which is deficient in these qualities is better adapted for the manufacture of worsted yarn.

**Different Methods of Manufacturing Worsted Yarns.**—All worsted yarns are not manufactured by the same system, but the different methods are closely related by having the same object (*i. e.*, laying the fibres smoothly in the direction of the thread or parallel), and in fact will more or less overlap each other. Some yarns, for example, such as are produced out of long-stapled wool (averaging five inches and more in length), the fibres after being cleansed and dried, are passed through a number of *gill-boxes*, and then combed, drawn and spun, whereas worsted yarns produced from short and medium-stapled wools (from two to five inches in length) are manufactured by carding, combing, drawing and spinning. Again, such worsted yarns as are used in the manufacture of carpets or low counts of knitting yarns (made of fibres of various lengths) are simply carded, passed through a number of gill-boxes, and all the drawing machinery previous to being spun, the combing being omitted. Slivers produced by either system are frequently mixed; for example, a *top* of long, medium quality material produced by one system may be mixed with one of fine, but short staple produced by another system, etc., etc.

**Principal Operations Composing the Manufacture of Worsted Yarn.**—There are in the manufacture of worsted yarn (technically known as worsted spinning) seven main operations, as follows: 1.—Sorting. 2.—Scouring. 3.—Drying. 4.—Preparing: *a*, carding, backwashing and gilling; *b*, gilling. 5.—Combing: *a*, nip-comb; *b*, square-motion comb; *c*, Noble comb; *d*, Little and Eastwood's comb. 6.—Drawing: *a*, open; *b*, cone; *c*, French. 7.—Spinning: *a*, fly-frame; *b*, cap-frame; *c*, ring-frame; *d*, mule.

**Sorting, Scouring, Drying.**—These three operations are the same as previously explained under corresponding headings in the chapter on the manufacture of woolen yarns, thus no special reference is necessary. In regard to sorting we must mention that the worsted manufacturer only wants the best fibres out of the fleece. The amount of rejection in a good healthy fleece, of fine wool, will reach from ten to twelve per cent., as wool is generally put upon the market by the American farmers. In coarse fleece the amount used is still less.

**Preparing wool for Combing.**—As previously mentioned two ways, according to length of staple, for preparing wool for combing are used. The long stapled material, (5 or more inches) is submitted to, or passed through the several gill-boxes (generally six) forming the *preparing-set*, whereas short and medium stapled wools are first carded and then passed through one or two gill-boxes corresponding to the fifth and sixth gill-box in the preparing-set.

**Preparing by Carding and Gilling.**

**A. Carding.**— This process is about the same as the process of carding for woolen yarns, thus no detailed explanation of the subject will be necessary. The carding engine used for this work is generally that known as a double cylinder card, but in some instances a single cylinder card is employed. An illustration in perspective of the former engine (as built by the Cleveland Machine Works) is given in Fig. 252. These cards sometimes contain as many as four licker-ins, increasing in fineness of their clothing from one roller to the other, and also correspondingly in their speed, hence the first licker-in will have the coarsest clothing and the slowest speed compared to the last licker-in which will have the finest clothing and the greatest speed. These worsted cards also generally contain a metallic breast, or a burring-machine, or both combined, being attachments to cards thoroughly explained and illustrated under corresponding headings in the chapter on woolen carding.

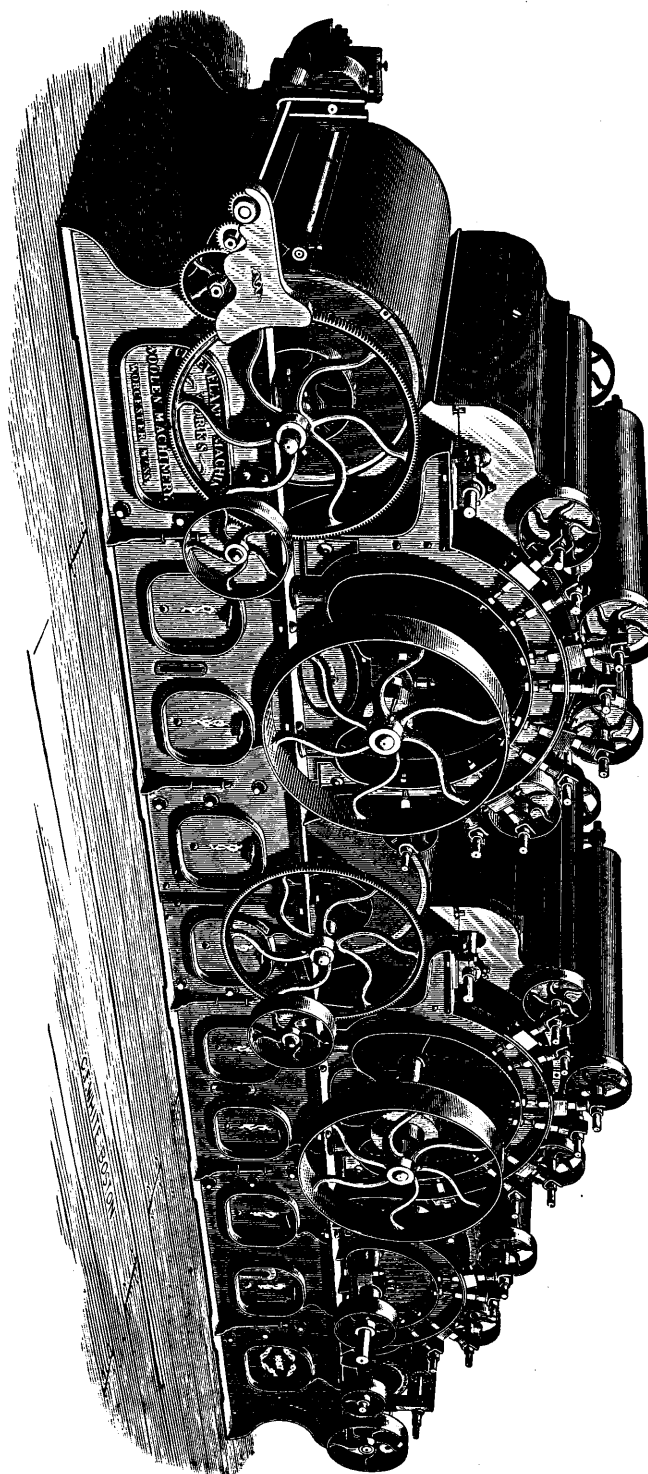


FIG. 252

The film thoroughly carded is stripped off the last doffer by the doffing-comb and condensed into the characteristic sliver by passing through a kind of funnel. It is then wound in balls. This is done either by means of calender-rolls as shown in Fig. 252,

or by a balling-head as shown in Fig. 253. The latter illustration represents the section of a double cylinder worsted card with four licker-ins and balling-head. After carding, the material is ready for those processes belonging more especially to the manufacture of worsted yarns, *i. e.*, backwashing, gilling, combing, drawing and spinning.

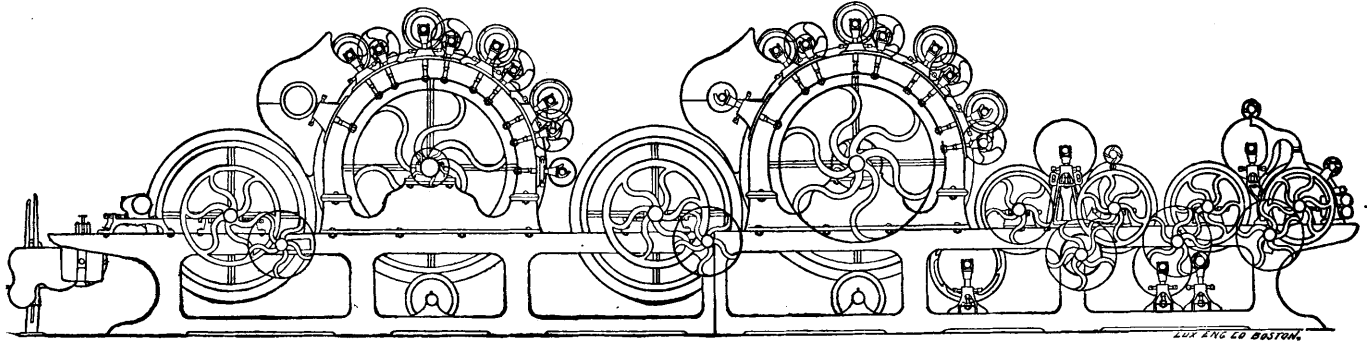


FIG. 253.

**B. Backwashing and Gilling.**—By means of these two operations as produced on the machine known as *combined backwashing and screw-gill-balling machine*, of which an illustration is given in Fig. 254, the wool is freed from oil (which had been previously added to facilitate carding), and discoloration, and is dampened, drawn, and straightened previous to being combed. A number of balls of slivers are put up in a creel in the rear of the machine; the ends are next passed through two vats, *A* and *B*, containing suds of hot soap and water, each vat possessing a pair each of immersing and squeezing rollers. After leaving the squeezing rollers *C*, of the second bowl *B*, the slivers pass over five copper drums *D*, (heated with steam to dry it) to the rollers of the gill-box *E*, of the machine. The

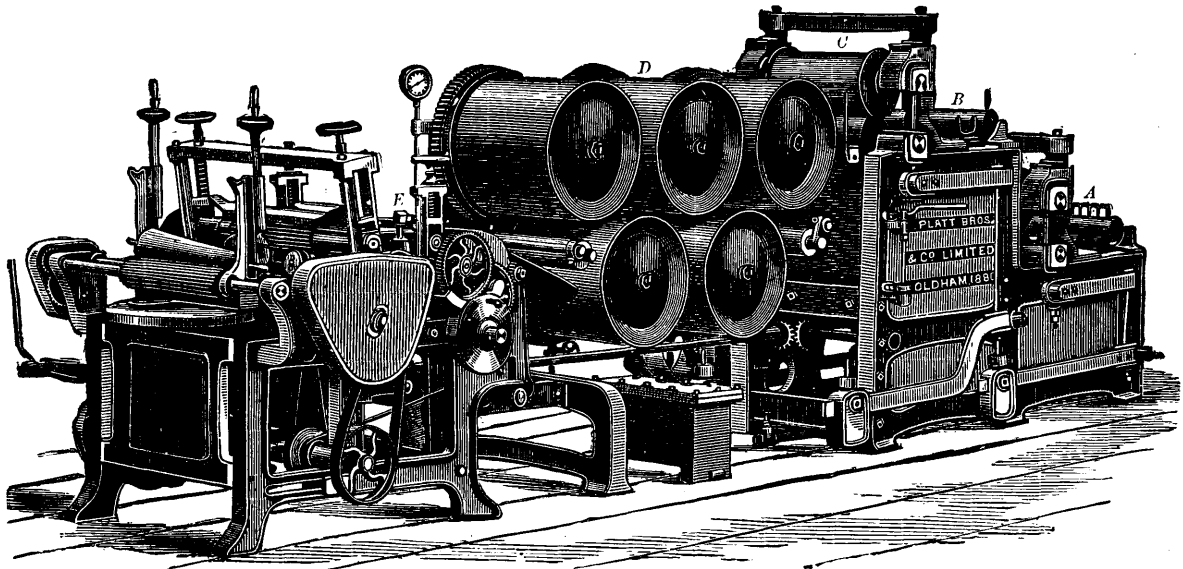


FIG 254.

object of the latter device is to straighten the fibres, that is, prepare the wool for combing. This method of gilling in connection with backwashing is similar to the gilling done by the preparing-set, which is explained in detail in the next chapter. According to the use of either one or two gill-boxes in combination with backwashing they equal the last or the two last gill-boxes of the preparing-set. Having thus far described the process of preparing short or medium long fibres for combing (carding and gilling) we have next to treat the preparing of long staple wools (five or more inches in length) for comb-

ing. Medium long stapled wools are at present also mostly carded, and if so the carding engines are built to suit this staple (not break it).

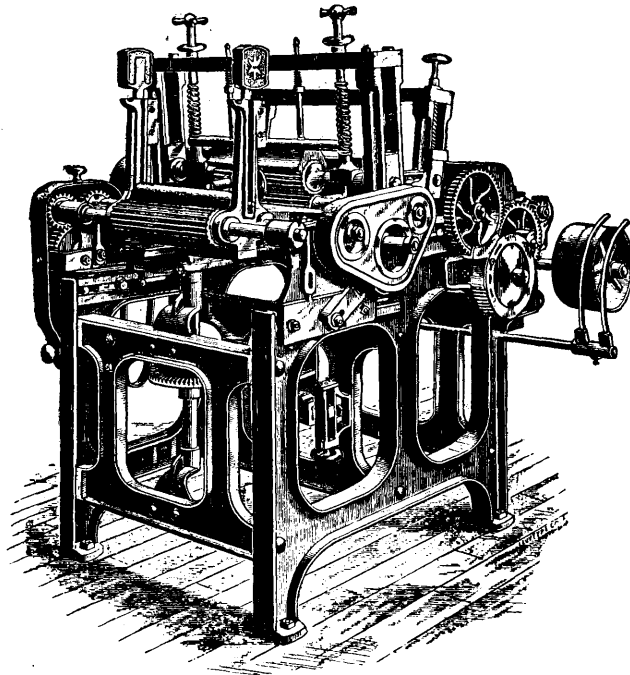


FIG. 255.

**Preparing by Gilling.**—If very long wool was carded a great many of the fibres would get broken by means of the wires of one roller catching one end of a fibre before being liberated from the wires of another roller. This, however, is not the case if dealing with short or medium stapled wools, since on account of their shortness the fibres do not cling to such an extent to the clothing of the rollers. To obviate this trouble for long stapled wools, the preparing for combing by means of screw-gill-boxes has been invented. This modus operandi consists in taking the wool and by a series of successive gillings straighten the long fibres of the wool intended to be combed, in order that the operation of combing may be conducted with greater facility and less damage to the staple. The preparing machinery consists of what are technically known as gill-boxes and of which there are generally five or six used in one preparing-set. The principle for either box is to straighten and separate the fibres of the wool preparatory to combing it. Fig. 255 illustrates such a gill-

box as used in a preparing-set. The main parts of it are the back rollers, the fallers and the front rollers. The wool is fed by hand, after being previously transformed, also by hand, into a kind of lap, with the fibres lying as much one way as possible, into the first gill-box and there received by a pair of fluted rollers known as feeding or back rollers. During this passage the material comes in contact with the pins of the fallers, of which a specimen is shown in Fig. 256 (being round or flat steel pins, fixed in rows in steel bars) which travel forward by means of two screws between the threads of which they run. When these fallers arrive at the end of the screws they drop down into a second pair of screws grooved in the opposite direction, which carry the fallers back again and below their starting point, from which they are lifted up to their working position in the upper pair of the screws (*i. e.*, ready for commencing again their forward journey) by an arrangement of cams fixed in the ends



FIG. 256.

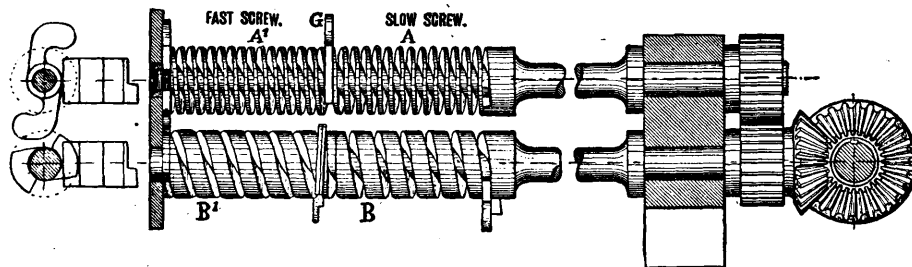


FIG. 257.

of screws. An illustration of the method of operation of these fallers is given in the chapter on Flax in the explanation of the spread-board.

**Improved Method of Working Fallers.**—An improvement in the modus operandi of these fallers as used for gilling has been made lately. An illustration of this improvement is given in Fig. 257.

Instead of the ordinary screws (the functions of which are to traverse the fallers) being one pitch throughout, or having four separate screws driven from each end by gearing, the inventor of this improved device makes each of the top screws  $A$ , and  $A^1$ , in one length, and each of the bottom screws  $B$ , and  $B^1$ , which return the fallers to a working position, also of one length, both sets being driven by bevel and spur wheels in the same way as when the machine is fitted with screws of the same pitch throughout. The portions of the top and bottom screws  $A$ ,  $B$ , next to the feed-rollers are cut with single threads for traversing the fallers, but the second portions  $A^1$ ,  $B^1$ , are cut with double threads which traverse the fallers more quickly. By doing so they straighten the fibres much more perfectly than can be done with the ordinary screws. The sliver, after leaving the feed-rollers, passes to the first set of fallers, which carry it to the ordinary stop at the usual place, but when it is taken to the second set of fallers, actuated by the double-pitched screw  $A^1$  the speed is actuated in proportion, and double the amount of draught is obtained. This, besides more thoroughly straightening the fibres, increases the production and makes it easier to do more work with the same number of machines, or the same work with fewer machines, besides drawing out any curled loop of wool, it at the same time permits the dirt to drop between one set of fallers and the other.

**Gill-Box.**—The draft in the gill-box is produced by having a greater surface-speed for the front rollers (drawing-rollers) compared to the back rollers (feeding-rollers), which causes the material to be drawn more rapidly through the first mentioned pair than delivered by the others. During its travel, from one pair of rollers to the other, the wool passes through steel pins which are set in steel bars (fallers), which operation separates the fibre, or, technically speaking, opens the wool. Great care must be exercised during the process of gilling or the fibres will be broken by the strain, and unfitted for worsted spinning.

**Preparing-Set.**—In the first and second gill-box, the material is, after each gilling process, wound in a lap, whereas after leaving number three box it is no more wound in a lap, but transformed into a sliver by being passed through a round hole in a piece of brass or steel, next drawn down by a pair of presser rollers and deposited in a sliver-can (similar to the one explained in the corresponding cotton processes). Generally six, or about that number, of these cans are put at the back of number four gill-box, and the union of the slivers (one from each can) submitted to the action of the machine, and drawn out from six to eight times their original length. This leveling of the slivers by doubling is the backbone for producing even worsted yarn, the same as it has been for cotton, since the more doubling done, the more even the sliver will get (the object is to so intermingle them, that the deficiency in one may be supplied by another, which possibly may be over supplied with material at that point), this process is also duplicated by each of the other boxes (number 5 or numbers 5 and 6 box) used in the preparing-set. The sliver when leaving the last gill-box of the preparing-set is wound automatically on a ball. If any oil is to be added to the wool, this is done on the fourth box by suitable arrangements, since any dust or fine dirt not previously removed from the wool will be shaken out during its passage through the first three boxes if the stock is not oiled.

The sliver thus finally produced (in the last preparer), by repeated doublings is comparatively level and the fibres composing the same, have been, by the continued use of the pins of the fallers, very thoroughly separated and put in parallel positions, but yet contain all the knots and broken fibres the wool originally contained, all of which must be removed by the combing machine. The points on the pins must be kept sharp, and such as get broken repaired as soon as possible.

**Combing.**—The original method, now extinct, of combing was by hand. The hand-comber in this process made use of two combs (similar to the one shown in Fig. 258). One of these he used as a pad comb, fixed on a post at a convenient height by an iron rod fastened into the post. The cleansed and oiled wool after being made up into handfuls (the staples laid parallel upon a bench) was lashed into each comb placed upon the pad. After each comb had been thus filled with raw wool, they were placed in the *comb-pot* for being heated, during which time the comber prepared again his

handfuls of wool for the next lot. He afterwards took the combs out of the comb pot, placed one comb upon the pad, and with the other in hand commenced the lashing or combing operation, each comb becoming alternately a working comb, by the teeth of one being made to pass through the tuft of wool upon the other, until the fibers of each became perfectly smooth, free and clear of short wool or *noils*, which were left imbedded in the comb heads. The combed wool, known as *tops*, were taken off by the comber with his fingers and laid evenly as possible into a sliver a few feet long, by drawing through a bone lined hole, whereas the noil, or short material, was next taken out, collected in a box and sold to woollen yarn spinners.



FIG. 258.

**Combing by Machines.**—As seen by the previously given explanation of hand combing, there is a two-fold object to be attained in combing by machinery, that is to continue the parallel placing of the fibres, partly accomplished by the previous process of gilling, and second to remove the short curly and neppy fibres (*noils*) from the long and straight fibres (*tops*) the former being unfit for use in the manufacture of worsted yarn.

The honor of having made the first practical attempt to solve the problem of wool combing by machinery (toward the close of the eighteenth century) belongs to the great genius Dr. Edmund Cartwright, and this without the advantage of special mechanical training or knowledge of the subject. He created the germ for all subsequent wool combing machines; no doubt some later inventors of such machinery have proceeded on lines distinctly their own, or even in ignorance of his invention but whichever wool comb we may take in consideration we find a reproduction of the principles of Cartwright's combing machine in it. Cartwright's original combing machine consisted of a cylinder, armed with rows of teeth which revolved in such a manner that its teeth might catch and clear out the wool contained in the teeth of the fixed and upright comb. His second combing machine, patented 1790, superseded the previous imperfect method by the contrivance of a circular horizontal comb-table.

The most frequently used wool combs of modern build are the nip comb, the square-motion comb, the Noble comb, and Little & Eastwood's comb.

**The Nip Comb.**—On the continent of Europe, (Austria, Germany, France, etc.) Josue Heilmann is generally considered the inventor of the nip system of combing, whereas England claims this honor for S. Cunliffe Lister, and G. E. Donisthorpe. Heilmann was the first to reach the Patent Office with the improvement, hence was in a position, when the two Englishmen brought out their nip machine, to obtain, in their own country, an injunction against them for infringement. Subsequently Heilmann's English patent right was bought by Messrs. Akroyd & Salt for £30,000, and resold by these gentlemen for the same sum to Mr. Lister. In this manner the latter obtained absolute control of the manufacture of these machines. Herr Lohren, a German authority on worsted combing says: "Lister's nip comb fulfills all the elementary principles of perfect combing, and yet it has neither a special combing apparatus, nor an intersecting comb, but only a feeding apparatus, in which however, are combined the effects of three of the operations necessary for good combing; *i. e.*, the filling in of the fibre, the combing of the ends, and the adequate preparation for the combing of the middle portion. It could only be accomplished after Heilmann had invented his celebrated nipper, therefore it is a combination of the invention of Cartwright & Heilmann."

Heilmann's machine, as invented by him, has been thoroughly described and illustrated in the previous chapter on combing cotton, hence no special reference to it is now necessary; thus we will give at once an explanation of the nip machine, as gradually improved by Mr. Lister.

**Lister's Nip Comb.**—An illustration of the latest form of Lister's nip comb is given in Figs. 259, 260 and 261. Fig. 259 gives a general view of the machine; Fig. 260 a sectional view, showing one drawing-off and two feed-heads, and Fig. 261 shows another sectional view of this machine. Letters of reference in all three illustrations are selected to correspond and indicate as follows: *A*, revolving comb-ring; *B*, *C*, one or two feeding and combing apparatus; *D*, a stroker; *E*, a drawing-off

apparatus; *E*, the noil rollers. The comb-ring *A*, has the usual shape, and is heated by the circular steam chest *a*, by means of the steam pipes *a*<sup>1</sup>. This combing is driven from the main driving-shaft

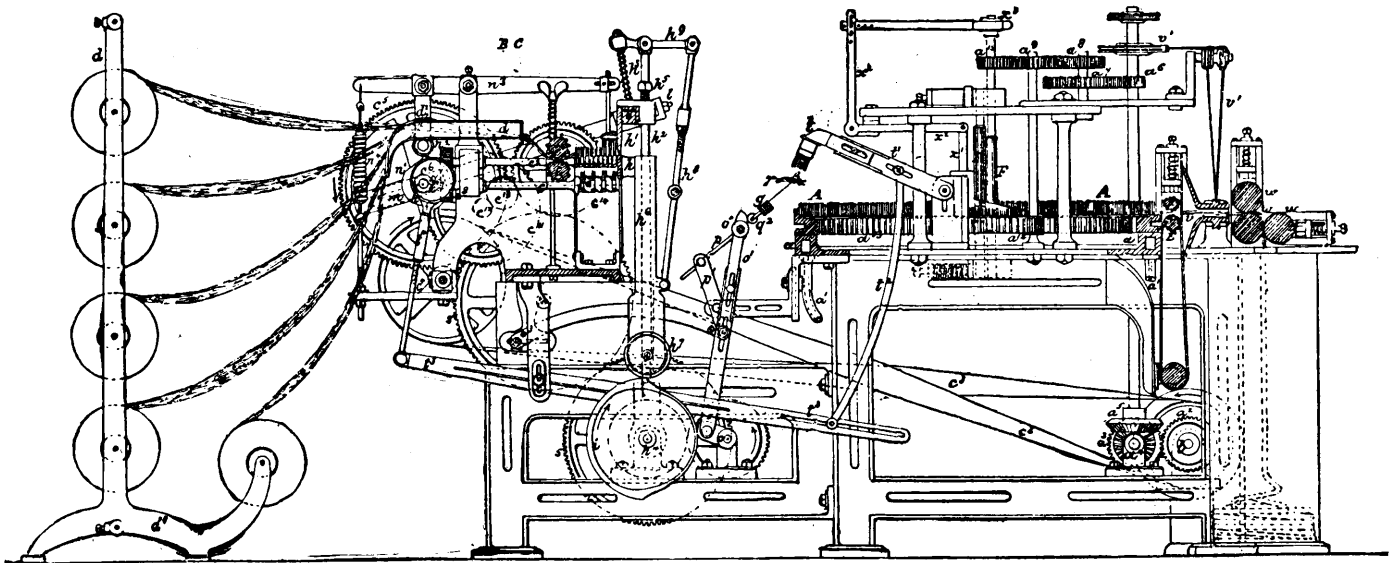


FIG. 259.

*b*, by means of the wheels *a*<sup>2</sup> to *a*<sup>13</sup>, of which the wheel *a*<sup>32</sup>, is geared with the teeth inside the comb-ring. Fig. 260 shows the arrangement of one of Lister's machines, with one drawing-off and two feed heads *B*, *C*, the latter being placed at right angles to each other. They are fixed firmly upon the frame of the machine, but are movable upon the slides *R*, *R*, and can be set to suit the length of the material which has to be combed.

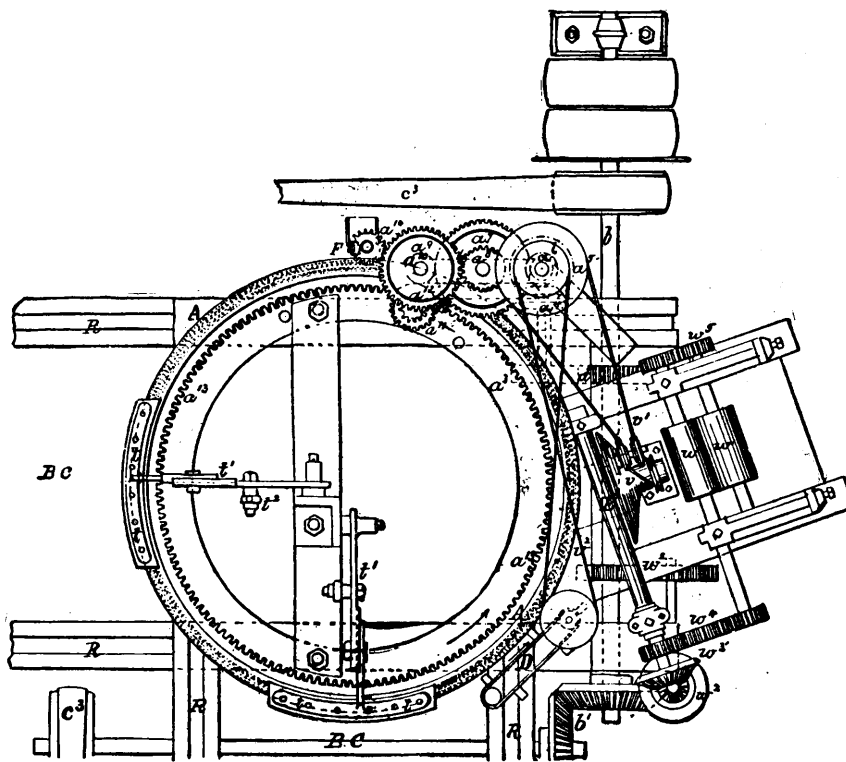


FIG. 260.

The front part of this feed head is constructed like a gill-box, without drawing-rollers. It consists of a polished guide plate *d*, the fluted drawing-in or feed-rollers *e*, *e*, and the fallers *c*, *c*. The balls containing the slivers for feeding the machine are placed into the bobbin stand *a*<sup>1</sup>, and are conducted over a divided plate *d*<sup>2</sup>, to the feed-rollers *e*, *e*. The lower screws *c*<sup>1</sup>, receive their regular revolving motion from the main driving shaft *b*, by means of the belt *c*<sup>3</sup>, the spur wheels *c*<sup>1</sup>, *c*<sup>5</sup>, and the conical wheels *c*<sup>8</sup> and *c*<sup>9</sup>. The

top screws *c*<sup>2</sup>, are connected with the bottom screws by the wheels *c*<sup>8</sup> and *c*<sup>9</sup>. The feed-rollers *e*, *e*, are driven by the wheels *c*<sup>10</sup> to *c*<sup>14</sup>. The peculiarity of the Lister nip comb, however, consists in the nipper *h*, *h*<sup>1</sup>



which takes hold of the fringe of the fibres projecting from and drawn forward by the fallers, and then deposits the drawn out portion of fibres upon the carrying-comb *g*. The latter places them in the teeth of the comb-ring *A*. The nipper consists of two jaws, the lower one *h*, with a grooved edge, the upper one *h*<sup>1</sup>, with a polished and rounded-off edge. The upper jaw slides upon the lower bar *h*<sup>2</sup>, and is pressed down by spiral spring *h*<sup>3</sup>; the lower bar *h*<sup>2</sup>, swings its lower end round the shaft *h*<sup>4</sup>, and its highest position is fixed by the adjusting screw *h*<sup>5</sup>. The lower jaw is fixed upon the tube or brush *h*<sup>6</sup>, which slides upon the bar *h*<sup>2</sup>, and bears at its lower extremity the truck *h*<sup>7</sup>, and at its side the connecting rod *h*<sup>8</sup>. The latter operates upon one end of the double armed lever *h*<sup>9</sup>, the other end of which presses upon and confines the spiral-spring *h*<sup>3</sup>. The opening and closing of the upper is caused by the cam or lappet *i*, keyed upon the revolving shaft *h*<sup>4</sup>, and upon the circumference of which runs the truck *h*<sup>7</sup>. The pressure between the two jaws of the nipper is regulated by the nuts upon *h*<sup>2</sup> and *h*<sup>6</sup>, and the spirals *h*<sup>3</sup>. Besides the opening and closing movement of the jaws of the nipper, by which it takes hold of the fringe of the fibres, a second movement is required to draw out the fibres from between the teeth of the

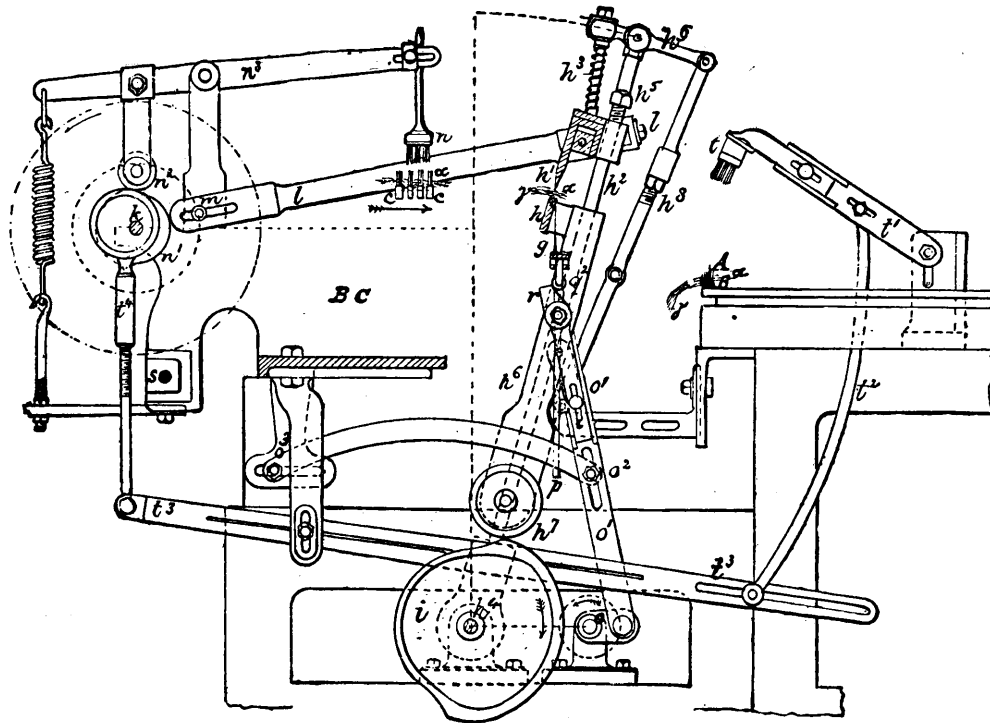


FIG. 261.

fallers and transfer them to the carrying-comb. This motion is produced, in a nearly horizontal direction, from the shaft *K*, by means of the slotted cranks *m*, and the connecting rods *l*, which are connected with the top jaw of the nipper by adjustable bearings. The action of this nipper is as follows: At the moment when one faller *c*, has fallen from the top into the bottom screw, and the next faller has advanced, the fringe of the fibres thus liberated as far as the screws will permit, the jaws of the nipper close upon this projecting fringe *L*, as far back as to bring the whole portion of fibre held by the faller just descended, and which portion contains the noils and impurities to the outside of the nipper. As soon as the fringe of fibres is nipped in between the jaws, the detaching movement begins by means of the crank *m*. To effect thereby the combing of the back end *y*, of the fibres, the brush *n*, descends into the pins previous to the fibre being detached, and remains in that position during this operation. The motion is given to this brush from the shaft *K*, by means of the lapper *n*<sup>1</sup>, the truck *n*<sup>2</sup> and the lever *n*<sup>3</sup>, tension being given by the spiral spring *n*<sup>4</sup>, at the oppo-

site end. The carrying-comb *g*, receives the ends *l*, of the detached tuft of fibres (Fig. 261) and places them so far over the teeth of the comb-ring *A*, that not only the uncleaned ends *L*, but also the still impure middle portion *B*, of the fibres is deposited within them, thus leaving only the combed ends *Y*, projecting from the comb-ring. From this it will be perceived that the drawing-off apparatus will produce a sliver of fibres combed perfectly clean along their entire length. The work of this carrying-comb is one of the most important features of Lister's machine. The same is shown separately in Figs. 262 and 263, and receives three combined, separate and distinct motions—a vertical one, a horizontal one and a change in the position of the points of its teeth from a straight line (Fig. 262) into a curved one (Fig. 263). The first is produced from the crank *o*, by means of the bar *o*<sup>1</sup>, and the lever *o*<sup>2</sup> *o*<sup>3</sup>; the second by the rod *p*, to the upper end of which the carrying-comb is fixed. This rod turns

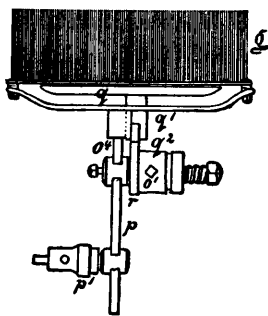


FIG. 262.

upon the axis *o*<sup>4</sup>, in the connecting-rod *o*<sup>1</sup>, sliding with its other end in a swivel upon the guide-bar *p*<sup>1</sup>. The third motion which changes the straight line of the points of its teeth into a curved one, and back again to a straight one, is produced by the teeth fixed into a curved spring plate *q*, (Figs. 262 and 263), which by the pin *q*, and the truck *q*, slide upon the slanting projection *r*, on the connecting-rod *o*<sup>1</sup>. These separate parts have to be arranged by a practical hand in such a manner that, when in the act of receiving the tuft of fibres, the carrying-comb advances in as near as possible a perpendicular position, close to the

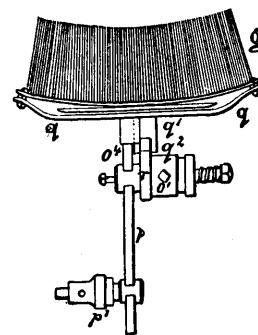


FIG. 263.

upper mouth and takes off the tuft of fibres; then changing its straight form into a curved one, approaches the comb-ring *A*, upon which it deposits the fibres in nearly a horizontal position, withdrawing from there so as not to disturb the parallel position of the fibres, at the same time placing the fibre ends as far over the comb-ring as to fulfill the above named conditions. To regulate all these requirements and to arrange them for different lengths of fibres, the connecting-rod *o*<sup>1</sup>, and the position of the bar *p*<sup>1</sup>, are adjustable, and the two ends of the lever *o*<sup>2</sup> and *o*<sup>3</sup>, are moveable in slots. The carrying-comb receives its motion from the crank-shaft *o*, driven from the nipper-shaft *h*<sup>4</sup>, by two equal spur wheels, the latter being driven from the main shaft *s*, by the two wheels *s*<sup>1</sup> and *s*<sup>2</sup>. The brush *t*, which serves to dab in the tuft of fibres into the teeth of the comb-ring *A*, receives its oscillating motion from the back screw-shaft *K*, by means of the lever *b*<sup>1</sup>, the adjustable-bar *b*<sup>2</sup>, the slotted lever *b*<sup>3</sup>, and the eccentric-rod *b*<sup>4</sup>. To avoid entangling and lapping over of the fibres of the tufts laid into the comb-ring, the projecting fringe is kept down by

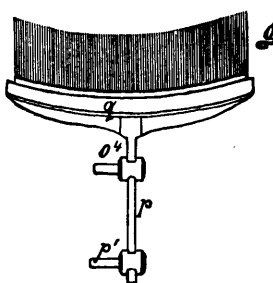


FIG. 264.

FIG. 265.

FIG. 266.



a current of air. The stroker *D*, is

in the shape of an endless band covered with small transverse bars. The form of the drawing-off rollers *E*, the tunnel *v*, and the pressure or balling rollers *w*, *w*, are already well known and will be understood without further description. They are set in motion by wheels *w*<sup>1</sup> to *w*<sup>5</sup>, for the lifting out of the noils, the noil knives *x*, are used, which working between the rows of teeth, raise up the noils and turn toward the noil-rollers *F*, (Fig. 259). Their lifting motion is produced by the rod *x*<sup>1</sup>, the square lever *x*<sup>2</sup> and the eccentric *x*<sup>3</sup>, the latter fixed upon the axis of the noil-rollers, which are driven by the wheels *a*<sup>14</sup> and *a*<sup>9</sup>. The tunnel *v*, is put in rotary motion by the band *v*<sup>1</sup>, and the stroker *D*, by the band *v*<sup>2</sup>.

This carrying-comb, so far described, (with moveable points) is chiefly used for short and fine wools; for long wools a fixed curved shape, as shown in Fig. 264, is employed, which then necessitates the same curve in the other corresponding parts of the feed apparatus, the jaws of the nipper and the fallers. Figs. 265 and 266 show a faller in that shape.

**Square-Motion Comb.**—This is the invention of Isaac Holden. The first patent in which the square motion principle was brought forward was taken out in 1848 in S. C. Lister's name but it did not represent the full application of the principle and the successful working of it, the chief merit of the present machine belonging to later improvements. In this machine the material is carried in the form of two thick ribbons by a pair of feeding-rollers, to the main comb constructed on the circular principle. These feeding-rollers have a to and fro motion and almost touch the teeth of the comb, on which they distribute a portion of wool and then recede, drawing or combing the fibres out in the meantime. Such of the material as remains on the inner side of the comb is known as noils. Previously mentioned feeding-rollers continuously supply material to the comb, and a great many of the fibres hang loosely from the pins over its side or edge in which condition they are carried round until coming in contact with the square motion, consisting of a set of fallers constructed in an arc form to work within the convex of the comb. These fallers have a quick motion, and are thus rather frequently introduced into the wool, carrying every time they raise a portion of the fibrous fringe as formed on the edge of the comb. Any noils they may contain are removed by a small comb, which is inserted between the pins on their descending. The combings are then delivered to a series of drawing-off rollers which convey them from the machine.

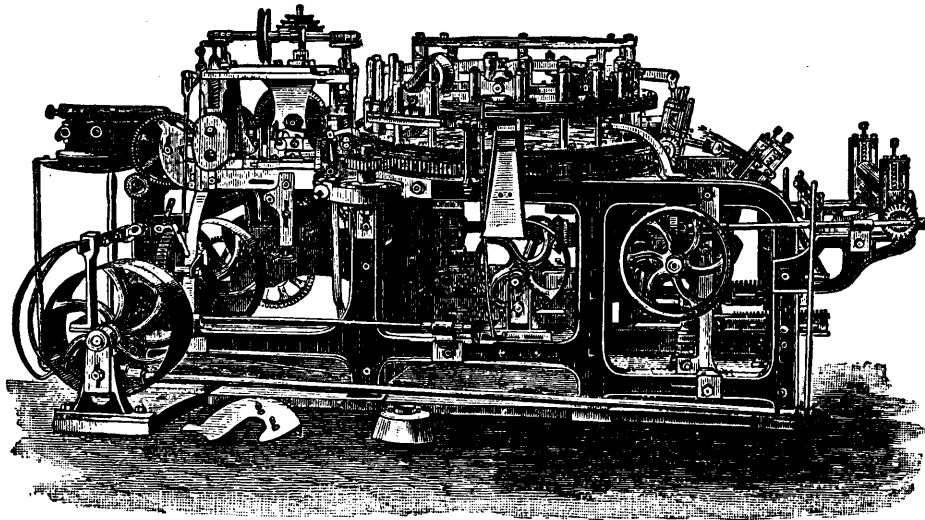


FIG. 267.

An illustration of a square-motion comb thus explained (illustrating an empty machine) is given in Fig. 267. Lohren makes the following remarks on this machine with reference to the feeding action and its effect on the sliver. As regards the feeding device in Holden's machine, it is constructed to the present day according to the manifold undervalued principle of Cartwright's which has often been declared to be the drawback of that system. It is in principle an imitation of filling-in by hand, and the objection against it is, that the comb which has filled in this manner cannot receive the fibre without entangling and knotting the ends, so as to retain them firmly. It cannot, however, be denied that this method of filling-in possesses certain advantages appertaining to no other feed apparatus, the first and foremost being that it effects a perfectly regular feeding or filling-in without necessitating a very carefully condensed sliver, the material being capable of being used without so much previous preparing as is required by other kinds of feeding apparatus. All of the better class of combing machines require slivers which not only have to be well carded, but have also to pass through two or more gill-boxes to give them the regularity and parallel position of the fibres which are requisite for a good working effect. Every passage of the fibres through a gill-box, however, not only diminishes the strength of the fibre, but also causes extra waste and expense. Holden, with his great practical clear-sightedness, has so constructed his machine that he can not only use any kind of sliver, but even loose

masses of fibre, and still effect a perfectly regular filling-in into the comb. This fact explains why materials can be combed by the square-motion comb which cannot be successfully combed on other makes, and can extract the long fibres from fibrous substances which others cannot work at all. However, there is one fact, this comb is not adapted for working long stapled wool, for if long fibres were to be dragged through the pins of the square-motion fallers, the power required would be very great, besides the fibres get seriously broken.

**The Noble Comb.**—This machine is the joint invention of G. E. Donisthorpe and James Noble. Noble having conceived the ingenious abstract principle of two circles working one inside the other was unable to design the *modus operandi* for it, hence consulted Donisthorpe, and it was the latter who

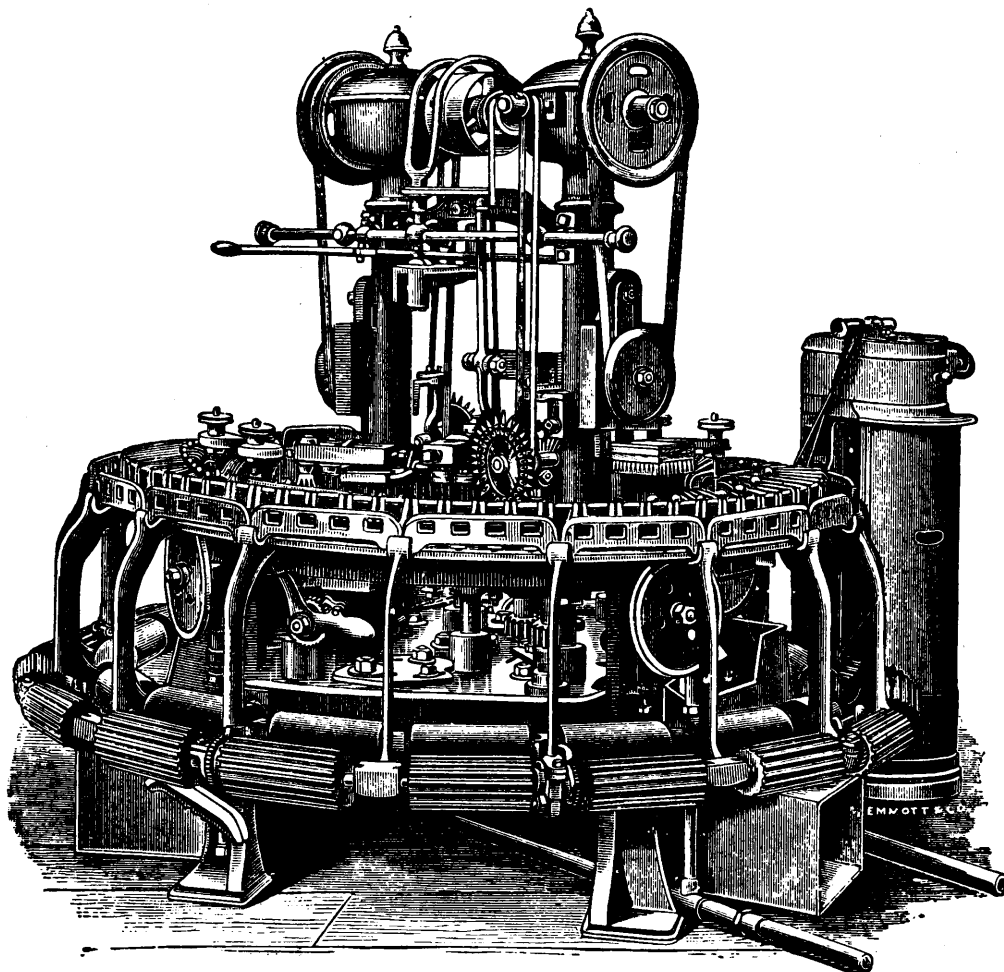


FIG. 268.

solved the problem. The patent was taken out in Noble's name since Donisthorpe was bound in honor to Lister (to whom he had sold his idea of the nip comb) to refrain from inventing different machines for wool combing.

The Noble Comb is the machine most frequently used in this country in worsted spinning mills and this with reference to wools of a short or medium staple; *i. e.*, for wools requiring previous carding, backwashing and gilling. The object of combing is to completely remove all flakes, specks or lumps, not removed by the carding engine, also any fibres too short (noils) for worsted yarn, and to thoroughly straighten the perfect fibres, or to lay them parallel to each other. To obtain this result the wool must be combed in both directions similar to holding some wool in one hand and combing it with the other by an ordinary comb. To comb the wool in question equally throughout, we

must, after combing the fibres of the part extending outside the hand, reverse the procedure and take hold of the loose ends, as previously combed, and next comb out the end held in the hand. This object is derived automatically in the Noble comb by dabbing the wool on two circular shaped sets of pins (technically called combs, and which are of different sizes, one from forty-eight to sixty inches,

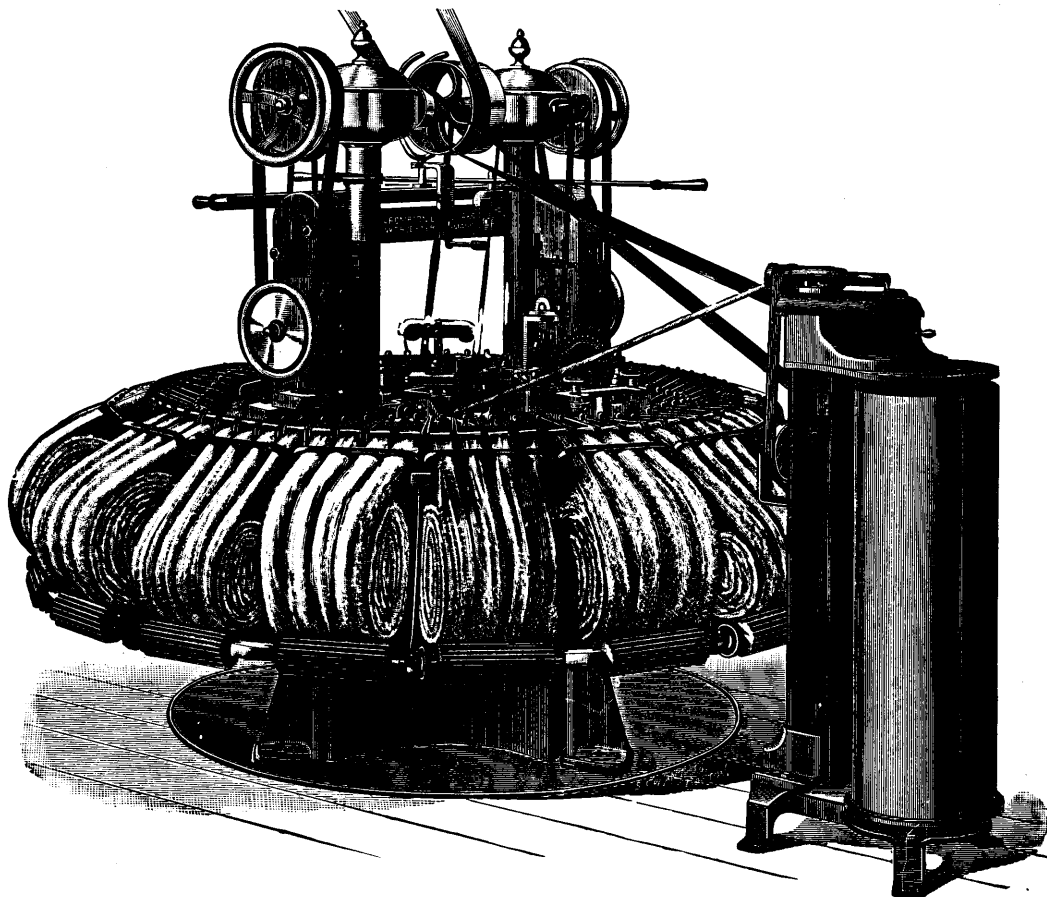


FIG. 269.

and the other from sixteen to twenty inches in diameter; the smaller comb working inside the ring of the larger one) at their place of contact, next parting these two sets of pins (in consequence of their circular shape) which will also separate the wool fibres (part adhering to each set), then drawing the wool out of each set of pins and finally uniting the fibres thus drawn out, producing in this manner what is technically known as the *combed-top*. The sets of pins are then stripped automatically of the short curly nappy fibres imbedded below the working surface (which are known as noils).

Diagrams Figs. 268 and 269 illustrate two perspective views of this comb. Fig. 268 shows the empty machine as built by Taylor, Wordsworth & Co.; Fig. 269 shows the comb as built by the Crompton Loom Works, known in the market as the *Crompton Noble Comb*, filled with slivers of wool, ready for work.

As will be seen by the latter illustration, the slivers are wound onto bobbins, which are placed in the circular rack surrounding the centre of the machine. These balls are made on a special balling machine, of which an illustration is given in Fig. 270, in the following manner: Four full sliver cans are placed behind the machine and the ends, one from each can, passed through the corresponding four guide rings *c*, next through the rollers in front and onto a bobbin which lies horizontally on a spindle at *a*, and is held tight between

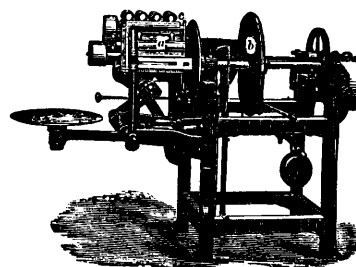


FIG. 270.

two plates. The machine is operated by means of friction wheel *b*, producing quite hard balls without imparting any twist, so that when transferred to the creels or racks of the combing machine they permit a ready unwinding. After placing these balls (18 in number) in the creel, their ends are passed through the feed-boxes situated above, made of brass, with a heavy lid, which act as tension to the sliver, preventing at the same time a slipping back of the sliver when closed. These feed-boxes are arranged all around and above the creel in a number (72) to correspond to the number of sliver ends (18 balls  $\times$  4 slivers each = 72) fed in the machine. Nearest to the delivery ends of the feed-boxes is a large circle from 48 to 60 inches diameter, containing around the circumference six or more (according to the grade of wool to be combed) perpendicular rows of sharp needles or pins. This circle and also creel and boxes rotate in unison from right to left. Below the circle is placed a circular stationary steam chest, and inside of the circle revolving in the same direction, and nearly in contact with it are two small circles, from sixteen to twenty inches in diameter, each one containing five or more rows of needles (according to the grade of wool to be combed). These two small circles are on opposite sides of the interior of the large circle (as shown in diagram Fig. 271) and as their action with reference to the large circle is identical only one need be described. As previously mentioned, these three circles of pins of the combing machine all move in the same direction; the small circles almost touch the main circle at one place, but by means of revolving separate from the latter, this being the principle

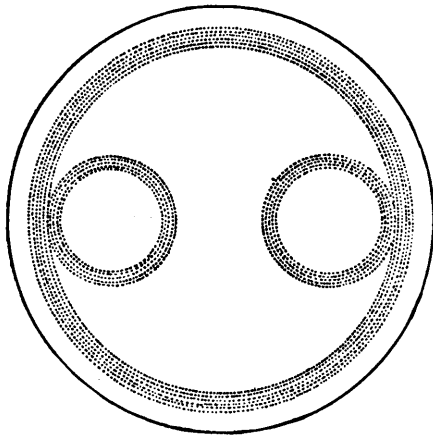


FIG. 271.

of combing. The carded and gilled, or only gilled material, as the case may be, is by means of, previously referred to, feed-boxes brought to the point of contact of the two circles, being constantly pulled through the boxes so as to extend over and beyond the large circle, thus projecting with its ends over the small circle. When in this position a dabbing brush (of which an explanation in detail is given later) running at a high rate of speed, up to a thousand dabs per minute if required, falls on the fibres pressing the same down into the pins of both of the circles. By means of revolving (as previously mentioned) the little circle will draw from the large circle as many of the fibres (of such as have been pressed in by the dabbing brush) as it is able to retain in its pins. Since only the ends of the slivers as fed in the machine project in the small circle such of the fibres as are retained by the same are the shorter fibres, whereas the long fibres extend outside or project from the main circle. Both

beards of the fibres extending outside of their respective circles have by the action thus far explained been thoroughly cleaned as well as straightened; *i. e.*, drawing off the ends of fibres belonging to the large circle through the pins of the small circle into which they have been overlapped and vice versa, the ends of fibres belonging to the small circle through the pins of the large circle. Any noils (very short fibres) as either beard originally contained will have remained in the pins of the circle by which the respective beard has been straightened. The next procedure is to draw the combed fibres out of their respective circles of pins, as well as to clear each circle of the noils, which is accomplished for each circle by a different device. The fibres extending from the small circle (which as previously mentioned are shorter compared to those of the large or main circle, yet sufficiently long to be used in the combed wool) are in turn met by the stoker or licker-in (being a wheel with sharp teeth projecting from it, and screwed on to it, which can be moved together and set at any required angle) which revolves very rapidly from left to right, and strikes the projecting fibres so as to turn the ends, which have been until now standing out, forward. After passing the stoker, the beard is met by a small pair of vertical drawing-off rollers, which catch all that projects, and draw it out, the pins of the circle at the same time combing (straightening and cleaning from noils and any other impurities) those fibres. The noils remaining in the pins are in turn lifted out of the circles by knives set between the rows of pins, and when brought on the surface by means of said lifting knives

tumble over into a can placed below the device for receiving the same. The large circle is cleaned by the following device: Its beard after being cleaned and straightened by the small circle soon comes into contact with a traveling leather apron, which goes quickly, drawing the points of the wool forward, hence acting in a similar capacity as the stroker to the small circle. The drawing-off-rollers are next approached and the leather passes around one of them. These draw off all the wool they can catch, and passes the same along between another part of the first leather and a second leather until meeting and uniting itself with the short wool sliver as drawn off from the small circle. As there are two small circles in the machine, and as the second acts similar to the one explained, there are thus two slivers composed of shorter fibres and two of long fibres, all of which unite, pass up a steel funnel, which puts in them a slight (false) twist. From there they pass through a trumpet and next to a revolving sliver can set outside the machine to receive them. This method is far superior to the old-fashioned style (and yet found in some makes) of passing the slivers through a pair of press-rollers into a long brass funnel and from there to the sliver-can, since by the modern arrangement the so greatly valued parallel position of the fibres (and this with as little as possible twist) in the sliver is preserved, hence less work and waste in the drawing process. If required the large circle slivers and the small circle slivers can be made to deliver into two separate cans. The modern build of Noble comb is also provided with a stop motion, which prevents laps on the drawing-off rollers, thus saving damage to combs, and also stops the machine when an end breaks.

**Dabbing Brush.**—The method of operation of the dabbing brushes in a combing machine has always been a difficulty, for unless the said brushes move very rapidly up and down, some of the wool will not be dabbed down just exactly at the point of contact between the two circles. But if the motion should be too quick, the brush cannot rise sufficiently high and then the wool gets ruffled and rubbed sideways during its passage below the brush.

An illustration of the dabbing brush (as built by Taylor, Wordsworth & Co.) is shown in Fig. 272, and which contains Lister's self-lubricating dabbing motion (shown in section) for its modus operandi. By its application the brushes can run up to a thousand dabs per minute if required, securing also a perfect pressing of the fibres in the pins of the circles. As the name implies, it is self-oiling, and when once charged with half a gallon of oil, will run a week without being touched again, and with a waste of only four drams.

Regarding the dabbing motion of the Crompton Noble Comb, the builders of this machine make the following statement: The Crompton Noble Comb is fitted with the latest-improved, high-speed, single-dabbing motion, and when desired it is supplied with the double-dabbing motion, as shown in illustration Fig. 269. This double-dabbing motion has demonstrated a marked saving in the wear and tear of the brushes as compared with the single-dabbing motion. A successful modification of the Noble Comb thus far explained is the

**1888 Comb.**—The same is built by the Crompton Loom Works, and is shown in its perspective view in Fig. 273. In its principle of operation the same resembles the comb from which it has been modelled; hence an explanation in detail of the modus operandi is unnecessary. Amongst different features of value to the manufacturer, we find: The new comb has only one dabbing motion, no upright pillars, drawing pulleys, shafts, etc., to obstruct the view of the attendant; in fact, she can stand at any one point and keep her eyes on all the wool boxes, consequently watch the feeding of the comb very readily. Doing away with these upright pillars, drawing pulleys, shafts, etc., greatly decreases the vibration of the machine by having the centre of gravity nearer the floor. Having a steadier running machine to deal with, we consequently can increase speed and in turn production.

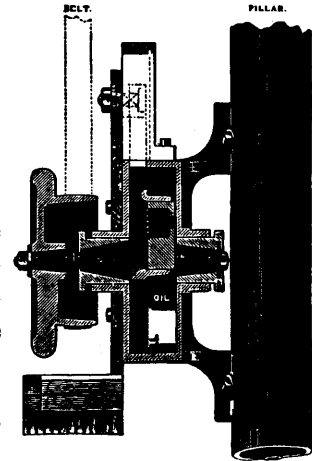


FIG. 272.

The dabbing motion of this comb is of the double or duplex type, capable of high speed, and clearing itself very freely.

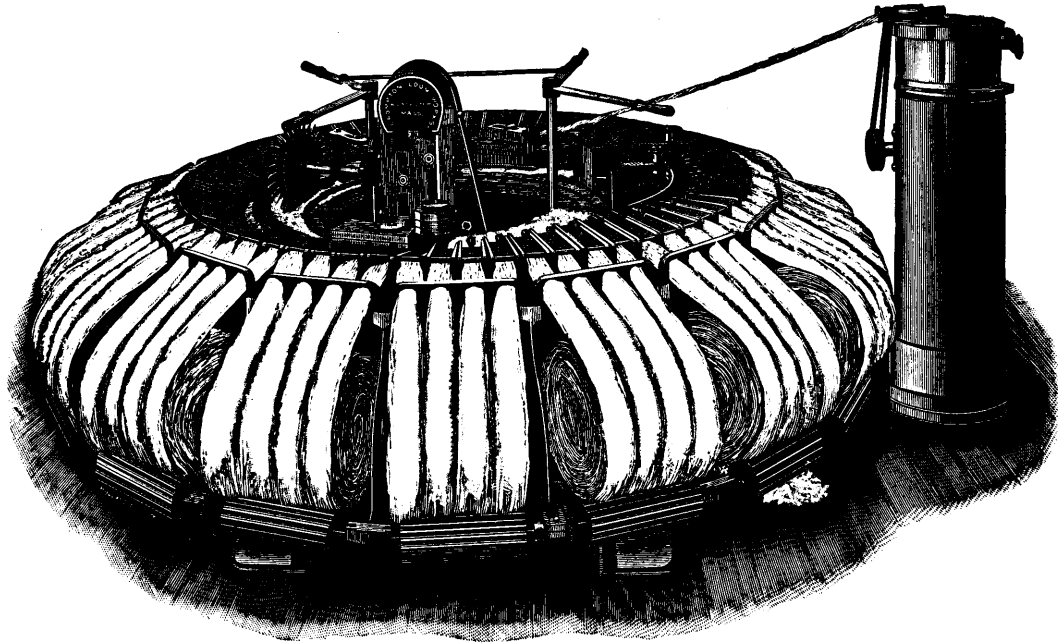


FIG. 273.

Little and Eastwood's Comb.—An illustration of this machine, as built by Platt Bros., is given in Fig. 274. In this comb the prepared or gilled wool, in the shape of 3 laps,

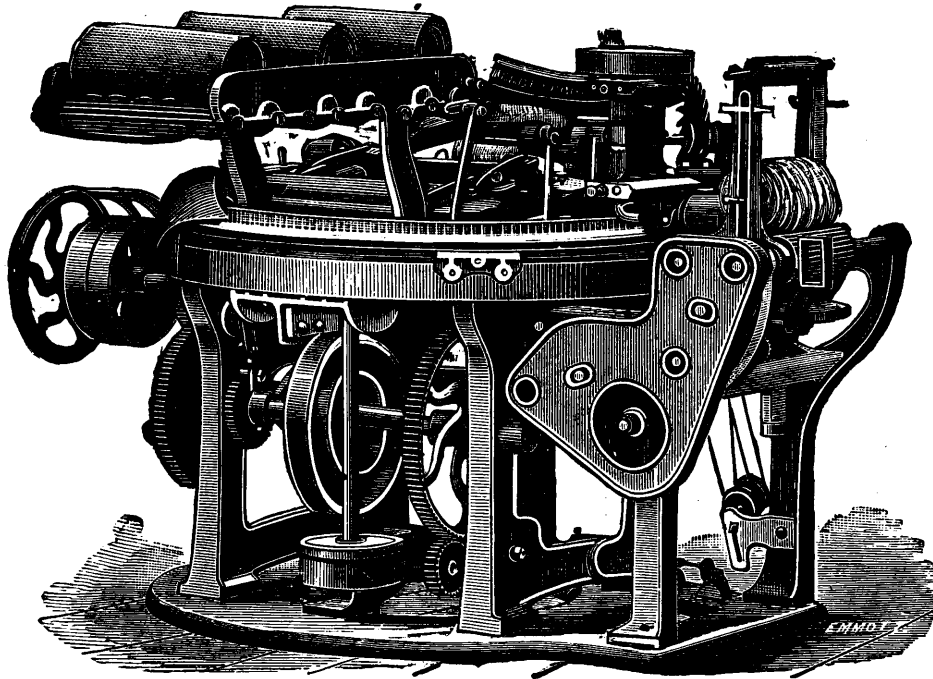


FIG. 274.

is fed onto the fallers by a pair of rollers having an intermittent motion. It is drawn by the jaws of the nip cylinder through the pins of the fallers, and deposited by it on the teeth of the



circle. The method of the operation of this cylinder is such that it places the wool on the comb with the uncombed ends behind the pins, while the combed wool hangs on the outer edge of the circle. The drawing-off rollers come next into action, and by drawing the fibres through the pins straighten the ends not combed between the nip cylinder and the fallers. The short fibres (noils) remain in the comb and are removed by stripper knives. In this machine the circle receives the wool with one end already combed, as hanging over its outer edge, hence less friction is occasioned in drawing the wool out of the comb than if all the fibres were combed between the pins, consequently less power is required to drive it, and less strain put upon the pins in combing the long fibres through them

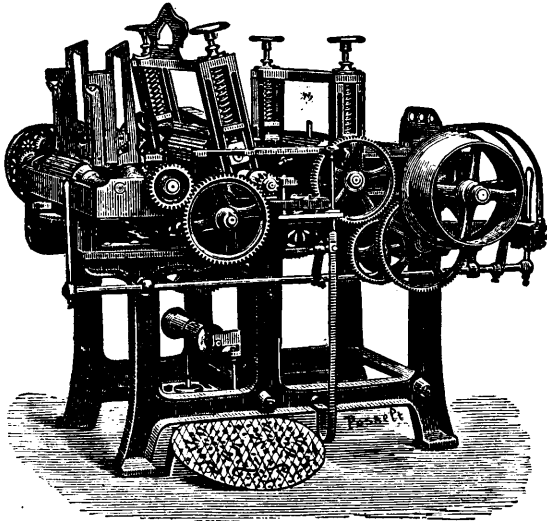


FIG. 275.

**Balling or Top Making.**—The slivers produced by either system of combing are next put up at the back of a *can-finisher* to further straighten out its fibres. The slivers when leaving the machine collect together again in sliver cans, which are then put up at the back of a *balling-finisher*, as shown in Fig. 275. The same is, as the illustration clearly shows, nothing but a common gill-box, in which the sliver, after its passage through the machine, is wound on a ball (instead of run in a can) by a suitable attachment in front. This ball device has an oscillating movement (constantly passing from side to side), hence the ball is produced by the sliver passing constantly from one side to the other and returning.

In some mills the combed sliver is wound directly onto large bobbins in place of these balls, which process results in keeping them smoother.

**Drawing.**—The principle of this process is the same as the corresponding procedure for cotton yarns; *i. e.*, combining several slivers, and extenuating them, repeating it several times, until a fine sliver is produced (roving), which when twisted will produce a thread of a certain required count.

There are three different systems of drawing for the manufacture of worsted yarns in use—open drawing, cone drawing and French drawing. Open drawing is used for long and short materials (according to style and build of machines), whereas the cone and French drawing methods refer to short or medium stapled material. The extenuating of the slivers as required for drawing is in all three methods accomplished by means of passing the sliver between two pair of rollers placed some distance apart from each other. The first pair of rollers, feeding-rollers, or back-rollers, revolve slowly, drawing the slivers of loose wool in between each other and feeding the same to the second pair of rollers, drawing rollers or front rollers, which revolve quickly and draw the wool out. This procedure is, as already previously indicated, repeated several times, until roving is produced by the action of the front rollers. The principle of drawing has been thoroughly explained and illustrated in the chapter on Cotton, pages 48 and 49.

**Open Drawing.**—The balls produced in the balling finisher are next put up in the rear of a *can gill-box* of which we give an illustration in Fig. 276. The same is a double machine, that is, the fallers are divided as shown in special illustration Fig. 277. The sliver-can (not shown in our illustration) is also divided up in the middle and all the rollers etc. are in double sets. Usually from five to six balls (equal number of ends fed in) are put up for each set of the box, which are thus combined and elongated in a single sliver of the dimensions of one of the minor slivers fed in. They are fed in at the back rollers *A*, travel forward in the fallers (one of which is shown in Fig. 277), next are drawn out by the front rollers *B*, and in turn pass through the press-rollers *C*, into the can. The top rollers *D*,

are for the purpose of conducting leather aprons around it and round the upper roller of the front roller

(*B*) set. The machine with which the sliver next comes in contact is known as the *two-spindle gill-box*, of which an illustration is given in Fig. 278. The same is a duplicate of the previously explained machine, the only difference being that the slivers as drawn through both pair of rollers are wound onto large bobbins, of about fourteen by nine inches inside measurement. The difference between the two latter explained gill-boxes and the

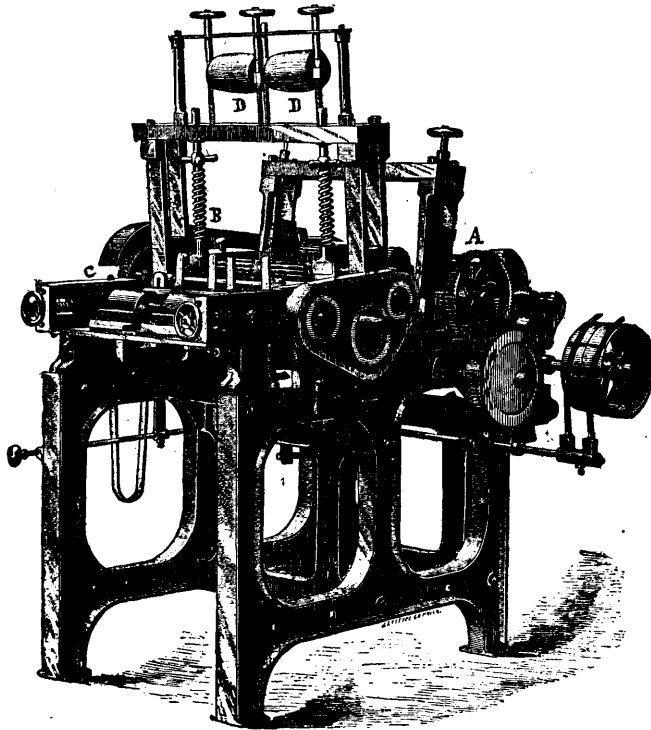


FIG. 276.

of the flyer-spindle, relatively to the speed of the front rollers, since the faster these front rollers deliver the end of the sliver, the less twist can the flyer-spindles, at any given speed put into it. The flyer-spindles receive motion by belts round pulleys *A*, from pulleys *B*, as fastened to shaft *C*. A special illustration of a faller used in a two-spindle gill-box, is given in Fig. 279. The *slubbing*, as the sliver is now called, is next delivered to the drawing-frames, also called *open drawing-boxes*, and of



FIG. 279.

which there are generally three machines used in succession. Since their method of operation is very similar we will explain them as briefly as possible. Five bobbins from the two-spindle gill-box are put up in the creel at the back of each spindle, the third box (or the *first drawing-frame*), and the five ends are united and elongated into one end rather thinner than any one of the minor ends. Four of these slivers thus doubled and drawn out, are next put up per spindle at the fourth box (or the *second drawing-frame*), united and elongated into one end still thinner. Four of these are next taken and put



FIG. 277

gill-boxes explained when dealing with the preparing set, consists, that in the can gill-box and the two-spindle gill-box, there must be no draft between the fallers and back rollers, for otherwise the ends would not be so even. When the slivers are wound round the bobbins, a small amount of twist (about a fraction of a turn per inch being sufficient) is put in by the flyer, regulated by the speed

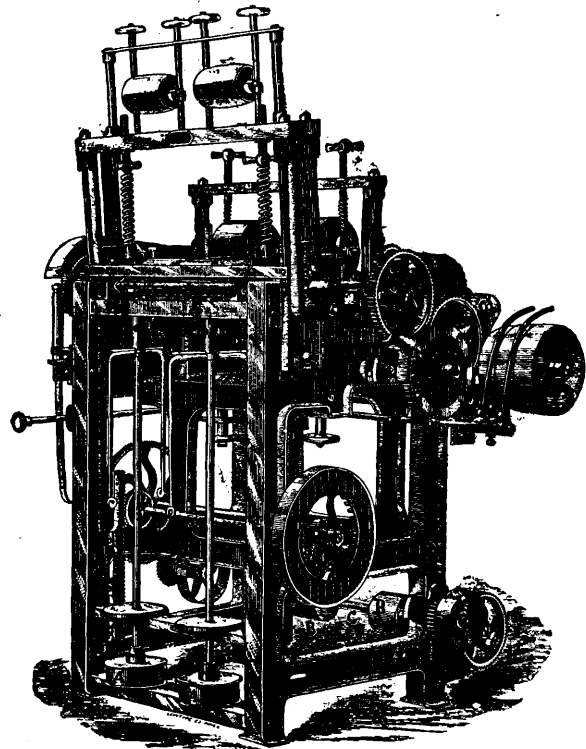


FIG. 278.

up per spindle at the fifth box (or *finisher drawing-frame*), united and elongated into one still thinner end. Of these, two ends are put up per spindle into the *roving-frame* producing in turn the sliver ready for spinning and technically known as *roving*. All these drawing-frames differ from the can gill-box and the two-spindle gill-box in having neither screws nor fallers, but only two pair of rollers (back and front) with two rows of carrier-rollers in between, which steady the material during the procedure;

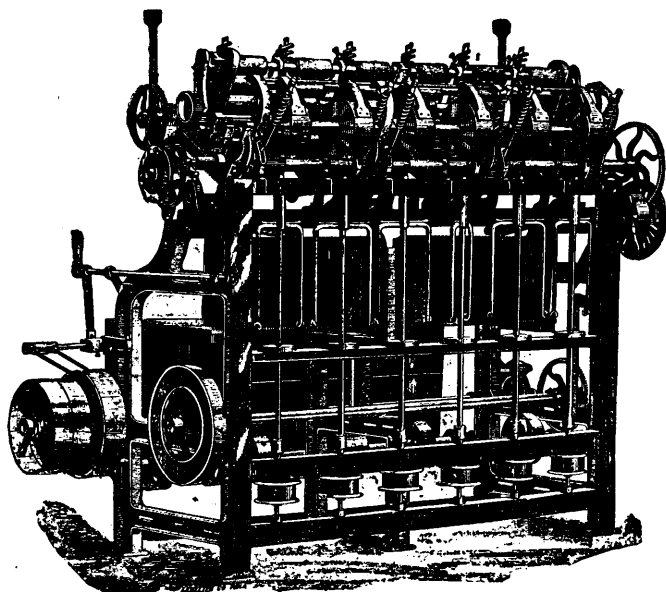


FIG. 280.

they run somewhat faster than the back rollers but have no relation to the draft. The fourth box (second drawing-frame) is also called the *weigh-box*, since there the weighing of the sliver is done more accurately (automatically) compared to either of the previous machines. An illustration of a *six-spindle drawing-frame* is given in Fig. 280. As already previously mentioned, the bobbins are taken from the finisher drawing-frame to the roving machines and the two ends united and elongated into one, the same as is done in the drawing-frames. An illustration of such a roving machine (also called *rover*) is given in Fig 281. These roving machines are built with up to thirty spindles, according to requirements.

The number of drawing-frames to use depends greatly on the stock and the

counts of yarns to spin since more operations will be required for fine counts, 60's or more, compared to the previously given arrangement. If spinning such fine counts, drawing without doubling (called reducing), must be added since for such high counts of yarn the roving must be correspondingly fine. Such a set as built by the well-known machine builders Prince, Smith & Son, Keightley, Eng., for such fine yarns consists of: *a*, 2 double-can gill-boxes; *b*, 2 two-spindle gill-boxes; *c*, 1 four-spindle drawing-frame; *d*, 1 six-spindle (weigh-box) drawing-frame; *e*, 1 eight spindle drawing-frame; *f*, 2 eight spindle drawing-frames; *g*, 2 twenty-four spindle (finishers) drawing-frames; *h*, 3 thirty-spindle reducers (elongating but not doubling); *i*, 9 thirty-spindle roving-frames.

For certain kinds of low grade wools as carpet yarns etc., the gill-boxes may be dispensed with and the drawing-frames used direct; however, some spinners use to support the wool, porcupine-rollers in place of the bottom carrier (the same as in French drawing).

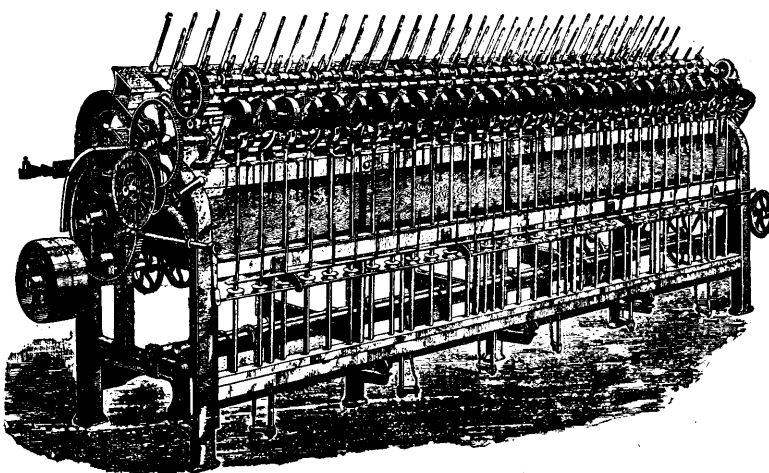


FIG. 281.

**Cone Drawing.**—The only difference between open and cone drawing consists in the method of changing the speed of the bobbins as they get gradually fuller in dimensions; the bobbin is made

to revolve at an increasing rate of speed as it becomes fuller entirely independent of the flyer which never drags it at all. The device by which the speed of the bobbins is regulated is known as the *differential motion*, which has been explained and illustrated in detail in the chapter on Cotton Spinning, hence no special reference will be necessary. In cone drawing there is no drag on the sliver as it comes from the rollers, thus the same can be wound onto the bobbins in the softest state possible, permitting an easier and more perfect drawing of the sliver.

**French Drawing.**—The principle of French drawing is to put no twist into the slubbing or roving, thus keeping the fibres as straight and parallel to each other as possible. This procedure requires different machinery from that used for the English drawing system (open and cone drawing). The balls

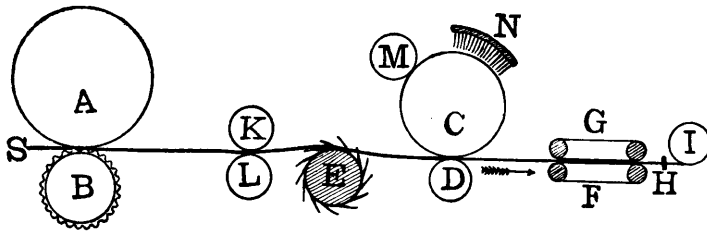


FIG. 282

or tops made on the comb are mixed in the usual way, in a can gill-box (see Fig. 276). The cans of sliver produced are next put up, two ends together, in the rear of the first drawing-frame, the ends are fed into the back rollers, and in turn passed between the front or drawing rollers which draw them out. Between both rollers is a porcupine-roller (revolving the least bit quicker than the back rollers) over which the sliver passes, *i. e.*, being drawn through its pins. This porcupine-roller acts only as a carrier for supporting the wool between the back and front rollers and prevents the yarn from getting twitty by holding the slivers when the front rollers are drawing. The drawn out sliver when leaving the front or drawing-rollers, is next passed between two rubbing leathers, similar to those used for condensers of the roving in woolen carding, which rub all its fibres together, without putting any twist into it, hence in this system of drawing, a round sliver is produced, compared to the flat or open sliver produced by the English system. The round slivers produced by the condensers of the French drawing-frame are next passed through a guide-wire and wound onto a horizontally placed wooden bobbin traveling at a good speed end-ways, thus causing the end to keep crossing backwards and forwards.

This principle of doubling and elongating the slivers is repeated successively in three or more machines being nothing but a repetition of the previously explained drawing-frame. Every succeeding operation still further reduces the sliver in thickness. To illustrate this method of drawing, Fig. 282 is given. Letters of reference in illustration indicate as follows: *A, B*, back-rollers; *C, D*, front or drawing-rollers; *E*, porcupine-roller; *F, G*, condenser; *H*, guide-wire; *I*, bobbin; *K, L*, carrier-rollers. Examining illustration we find that

the upper situated roller in both, the back and front roller set (*A* and *C*) have a larger diameter compared to their companion rollers (*B* and *D*). The work to be performed by rollers *A* and *B*, consists in pressing the sliver *S*, to permit its drawing out by means of the front or drawing-rollers *C, D*, respectively, by the porcupine-roller *E*. Roller *A*, will act as a press roller by means of its own weight and in order to insure perfect work (pressing of the sliver) roller *B*, is fluted. Rollers *C, D*, are both smooth and covered with parchment paper. The pressure of roller *C*, gets increased by means of weights or springs. The small roller *M*, has for its object to apply the loose paper cover to the roller *C*, and brush *N*, is placed there for the purpose to keep roller *C* constantly clean. To give a clear understanding of the workings of the back, porcupine and front rollers (leveling or straightening fibres) illustration Fig. 283 is given. In the same: *A*, represents the feeding or

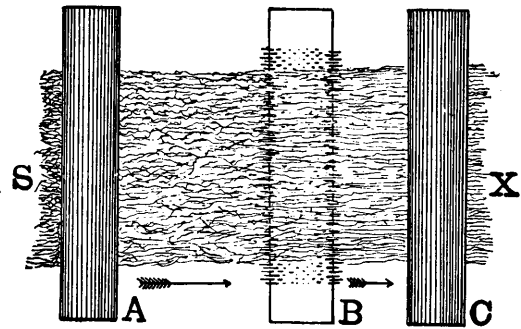


FIG. 283.

back-rollers ; *C*, front or drawing-rollers with *B*, the porcupine-roller ; *S*, the sliver as fed to the back-rollers, and *X*, the sliver as leaving the front-rollers after having been subjected to the action of the porcupine-roller *B*. Fig. 284 illustrates a drawing-frame built by Platt Bros. After leaving the finisher drawing-frame, the now greatly reduced sliver is submitted to the action of the roving frame, which machine continues the work of doubling and elongating the slivers, except that the bobbins are filled more slowly and evenly, and this with a fine sliver now called roving.

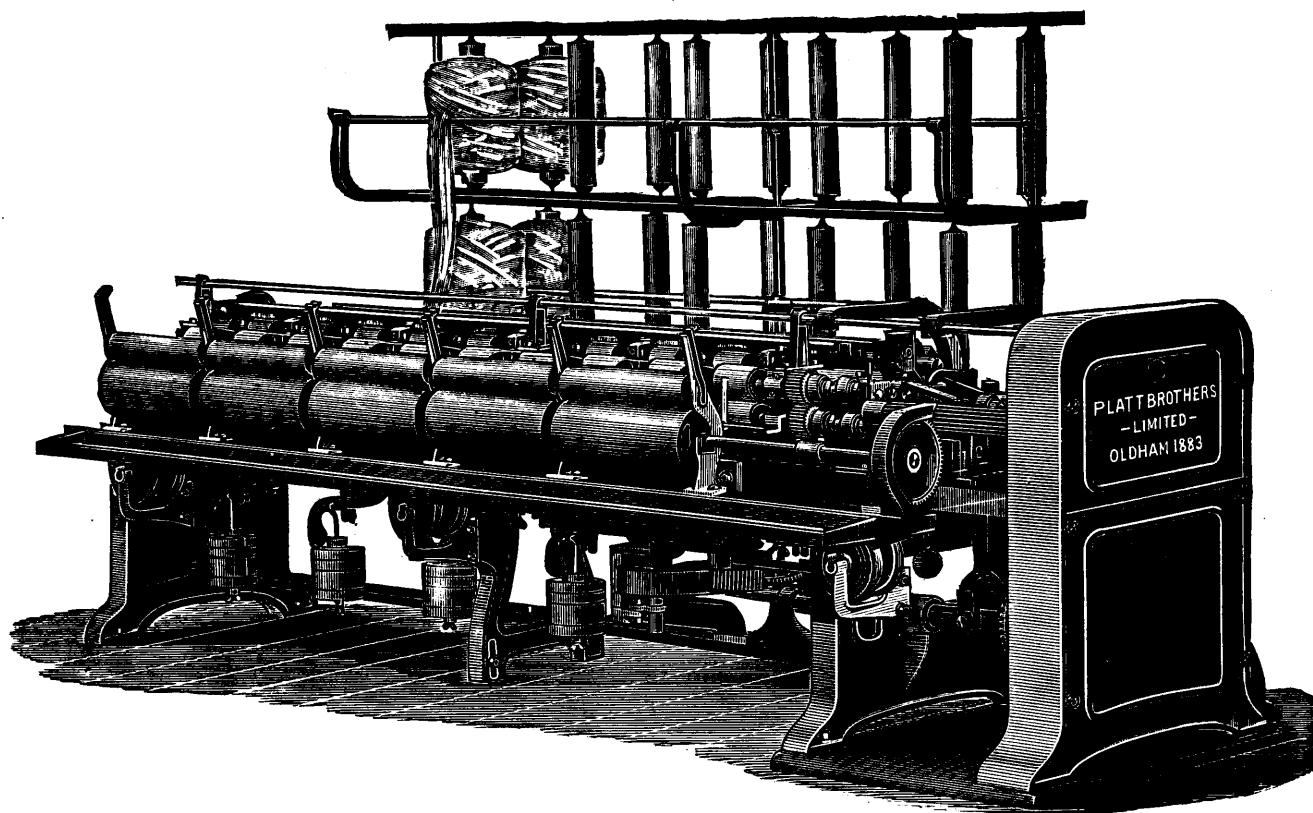


FIG. 284.

The Set of French Drawing Machinery, built by Platt Bros., as exhibited at the Royal Jubilee Exhibition in Manchester, is explained by this firm as follows: After the material is combed (Little and Eastwood's comb) it is run through a screw-gill balling machine, consisting of one head of two deliveries to make two balls for the next process.

**First Drawing-Frame.**—With four boxes, eight porcupines and four bobbins, fourteen-inch traverse doubling two ends into one. The slivers or balls are taken from the last process, and in this machine are doubled two into one with a draft of about four. The two slivers to be doubled pass first through the taking-in rollers, then over a porcupine-roller, and through a pair of front-rollers, which, running faster than the surface velocity of the porcupine-rollers, causes the fibre to be straightened whilst being drawn through the teeth of the latter, and after passing between the rubbers, without putting any twist in it, forms it into a round sliver and carries it forward and delivers it to the bobbin, which is driven by surface contact with a calender or surface-roller.

**Second Drawing-Frame.**—With four boxes, eight porcupines and four bobbins, fourteen-inch traverse doubling two into one, being a repetition of the first drawing-frame; the sliver by the operation of this machine is still further reduced in thickness.

**The Slubbing-Frame.**—Contains four boxes, eight porcupines and eight bobbins, seven inch traverse doubling two or four into one constructed like the drawing-frame, but the sliver is again still further reduced in thickness.

**The Roving-Frame.**—Contains four boxes, eight porcupines and eight bobbins, seven inch traverse, doubling two to four into one. This machine finishes the drawing process under the French system, the bobbin from this machine being ready for being spun on the mule.

**Spinning.**—The spinning machinery for worsted, closely resembles the spinning machines used for cotton yarn, of which a detailed description with numerous illustrations is given in that chapter. Four distinct machines for worsted spinning are more or less in use: 1st, the flyer spinning-frame; 2d, the cap spinning-frame; 3d, the ring spinning-frame; 4th, the mule.

**Flyer-Spinning.**—This system of spinning, as well as the others, may be divided into three parts: *a*, the elongating of the roving; *b*, the putting in of the twist; *c*, the winding. To illustrate these three motions in connection with the fly spinning system, diagram Fig. 285 is given. Each bobbin, containing roving, is placed on a pin *A*, in the creel *B*; next the end of each bobbin is passed between the pairs of rollers *C*, *D*, *E*, *F* and *G*, from where it is guided on to the bobbin *H*, passing previously around one of the legs of the flyer *I*. The elongating of the sliver is done between the feeding or back rollers *C*, and the drawing or front rollers *G*, by means of having the latter pair revolve more quickly than the first, hence drawing out the roving in its length in proportion to the difference in surface-speed between these two pair of rollers. The lower roller of the front roller set *G*, is furrowed and its diameter regulates the amount of draft; the upper roller is simply a presser-roller, being a wooden boss covered with leather and rotating by friction. The three small pairs of rollers *D*, *E*, *F*, as situated between the two large pairs, or working rollers, are simply carriers for conveying the roving from *A* to *G*. When the thus elongated sliver of roving leaves the front-roller set *G*, it is twisted once or twice around one of the legs of the flyer *I*, passed through a twizzle at its lower end, and then wound round the bobbin *H*, as placed on the spindle *K*. The flyer is screwed to the spindle at the centre of the cross-

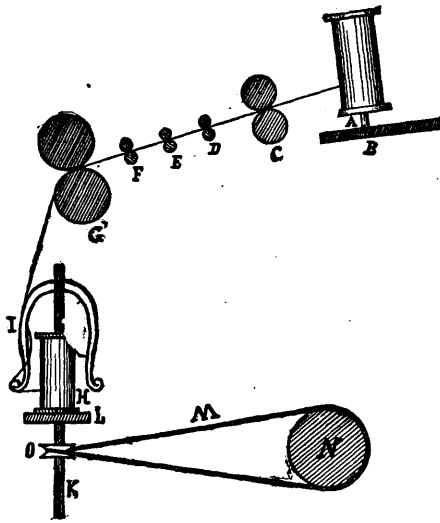


FIG. 285.

piece. The bobbin travels up and down on a lifter-plate (carriage) *L*, by the action of a heart shaped piece of iron (heart-motion) and a series of chains and pulleys. The shape of the bobbin as required regulates the shape of this heart. The spindles themselves (see whirl *O*, fastened to the spindle) are driven by spindle bands *M*, from a cylinder or drum *N*, the latter extending throughout the length of the machine. The flyer is the medium for keeping the thread at one regular tension, imparting the twist to the yarn and winding the yarn on the bobbin. The yarn spun by this flyer spinning-frame (which is the oldest system of machine spinning, and invented by Richard Arkwright) is very strong and smooth, and most suitable for low counts of yarns (below 30's). The amount of twist put in the yarn depends on the respective speed of the bobbin and the flyer.

**Cap-Spinning.**—The principle of cap-spinning is quite different from the previously explained system, and is used for spinning finer counts (of from 30's to 40's, or thereabouts) of yarns. An illustration of the *cap-frame* is given in Fig. 286. As already mentioned when explaining the fly-frame, the elongating or drawing out of the roving is identical for fly and cap-spinning, and hence consists of the feeding and the drawing-rollers as well as the carriers. This will leave us only the explanation of the *modus operandi* for imparting the twist and the winding of the thread on the bobbin. To illustrate

these two points, Fig. 287 is given. The spindle *A*, and the cap *B*, have no rotary motion. The spindles do not reach to the bottom rail, as is the case in the fly frame, the cap as placed upon them is a steel cup, shaped like a bobbin, but rather larger, to permit the bobbin to enter even when filled

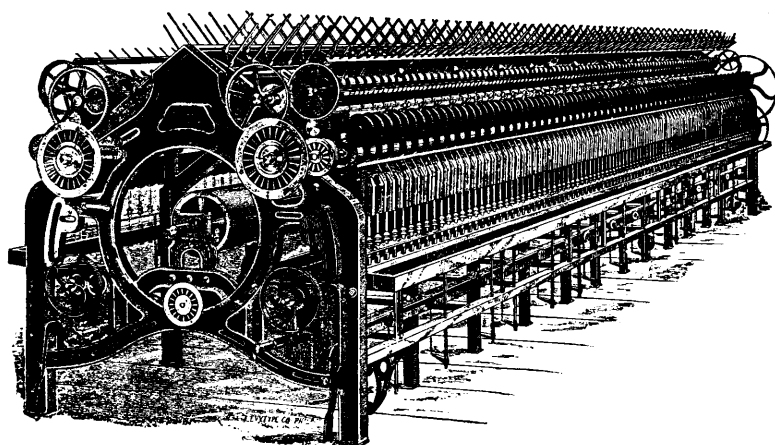


FIG. 286.

whirling against it to the lowest possible minimum. must be taken off when doffing. On the spindle *A*, is placed the rotary part, consisting of a small tube or shell *D*, to which is attached the whirl *C*. The shell *D*, receives motion from the drum or cylinder *N*, (as extending from end to end throughout the machine) by means of driving bands *M*, in a corresponding manner to the spindle in a fly-frame. The shell in turn imparts its motion to the bobbin, to which an up and down motion is given (so as to distribute the yarn regularly on its circumference) by means of the whirl resting on the carriage or lifter rail of the machine. The difference between fly and cap spinning is simply this: In the former the flyer revolves around the bobbin, thus imparting twist, whereas in the latter system, we find the bobbin revolving around the spindle and inside the cap, hence imparting the twist itself. The number of times the bobbin revolves during the time the front-rollers deliver one inch of roving regulates the amount of twist (turns) per inch. To prevent the ends from flying into each other when ballooning, separators (tin shields) are placed between the bobbins.

**Ring Spinning.**—The principle of this method of spinning has been thoroughly explained and illustrated in the cotton chapter, hence a special reference to it is unnecessary. It is used with success both for spinning and twisting worsted. Mention has been also made on pages 61, 62 and 63 of some of the most prominent spindles as used in connection with ring spinning. Lately a new spindle, known as the *Bates' Spindle*, has come in the market, of which an illustration is given in Figs. 288, 289 and 290.

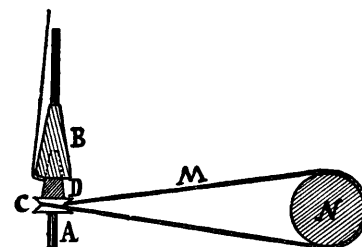


FIG. 287.

with yarn. Its lower rim is perfectly smooth (polished) so as to reduce the friction of the thread

These caps remain on the frame when spinning, but

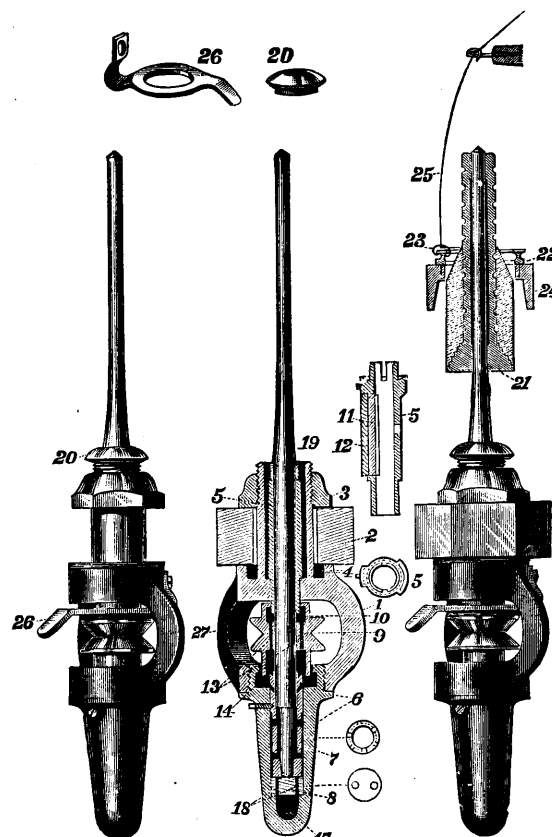


FIG. 288.

FIG. 289.

FIG. 290

Fig. 288 is an elevation, showing all the parts in working order. Fig. 289 shows all except the steel spindle itself in section. Fig. 290 shows the spindle and all parts belonging to it in elevation, and the bobbin, ring and ring traveler in sectional view, also showing guide and thread, thus illustrating the entire procedure of ring spinning.

The spindle is supported in a holder attached by a retaining nut to the bolster rail of the spinning frame. The whirl driving the spindle is below the bolster rail. The spindle has two bearings, one above and one below the driving whirl. The band driving the spindle has, therefore, the resistance equally divided between the upper and lower bearings. The holder is separable at the lower extremity of the yoke, and thus enables the spindle to be removed and replaced at pleasure, without disturbing the adjustment of the bolster bearing.

The spindle proper has an egg-shaped or parabolic foot which rests and revolves upon a flat, hardened disc. The foot is not confined, so that there can be no binding or friction by reason of want of alignment with the upper bearings. In the upper part of the yoke there is an annular chamber for holding oil. A wick feeds this oil by capillary attraction to the upper part of the bearing. The lower part of the support has ample space for a store of oil. Below the disc, upon which the spindle revolves, there is a chamber into which the sediment from the oil can collect, and from which it may be removed occasionally.

A description of the construction of the spindle, with reference to letters of reference in illustration is as follows :

The spindle support consists of an upper section (1), which fits from below through an opening in the single rail (2) of the machine frame, resting with a shoulder against the under side of the rail, being drawn up and held in position by a nut (3) upon the upper part. An oil receptacle (4) is formed around the central portion of the upper part of the bearing, within the shoulder, which receives an absorbent packing, and is in fluid communication with an oil-space in the central cavity, containing the upper bush or bearing (5). A lower section (6) is screwed into the bottom of the upper section, containing the lower bush or bearing (7) and the bottom or end-bearing (8) and an oil receptacle. In the upper section (1), which is bored out concentrically with the screw and shoulder already referred to, is inserted the upper bushing or sleeve (5), extending downwardly into a chamber (10) formed in the upper side of the whirl (9). A steel plate (11) is inserted in the bushing (5) on the side receiving the draft of the driving-band, with a wooden strip (12) laid under it. The whirl (9) has apertures (13) made through it, reaching from the upper cavity (10) into the lower cavity, through which oil can descend but cannot be whirled off by reason of the lower rim (14) of the whirl extending into a chamber formed in the lower part of the support. A bushing (7) removably fitted into the lower part of the support serves to centre the lower end and a hardened steel plate (8), beneath the spindle, supports the weight. The bushings (5) and (7), which form the bearings, are not made with continuous outer surfaces to fit in the casing portions of the support, but are fluted or grooved so as to provide oil channels (15) and (16) and chambers between the bushing and the casings.

Below the hardened steel bearing (8) there is a cavity (17), into which any foreign substances in the oil can subside without injury to the bearing. A cap (20), fitted loosely around the spindle (19) at the top of the bearing (1) serves to exclude dust, and is easily raised by the spout of the oiler. An oil-chamber (4) is formed around the bearing, which being filled with an absorbent, saturated with oil, insures continuous lubrication for a long time.

The portion of the bearing surrounding the whirl is formed with curved pillars and intervening open spaces so as to permit easy access to the whirl for the driving-band, and to afford opportunity for inspection.

An elastic plate of metal (26), secured by a screw to the upper part of the bearing at the rear, and extending across the upper surface of the whirl, with a projecting ear at the front, acts as a break when pressed against the whirl, so that the motion of any spindle can be arrested without affecting that of any other.



**Mule.**—The mule is the *modus operandi* for imparting twist into roving produced by French drawing. The worsted mule differs in its action from the woolen mule, where only a single pair of rollers (delivery-rollers) for delivering the roving from the roving-spools are used, but closely resembles the cotton mule. The elongating of the roving is produced in the same way as explained for the fly-frame, viz., feeding-rollers, carriers and front-rollers, but being placed horizontally in the mule compared to the oblique position in the fly-frame. The twist (by means of the spindles) is put in the yarn during the time the rollers deliver the elongated roving. The carriage containing the revolving spindles runs out steadily, from the rollers, so as to keep the yarn taut. When arriving at the end of its journey the delivery of the roving ceases as well as the quick revolution of the spindles, and the running in of the carriage commences. During the running in of the carriage, the length of yarn spun is wound on the bobbin, guided by the faller wires, which are thus actually the builders of the bobbin. The winding of the yarn on the bobbin is done by the spindles, which after stopping for a moment, commence to wind on the yarn as soon as the carriage commences to run in. (The building up of the bobbin or cop, *i. e.* the working of the fallers etc., has been explained in detail in the chapter on the mule in Cotton Spinning). As soon as the carriage has arrived again in front of the rollers it stops for a moment, the rollers commence to revolve, the elongated roving is delivered, the spindles begin their quick revolution, and the carriage simultaneously commences again its outward journey.

Diagram Fig. 291 is given to illustrate the principle of drawing as done in mule spinning. Letters of reference referring to the method of operation indicate as follows: The roving *S*, enters between the feed-rolls *A*, *B*, and from there between the drawing rolls *C*, *D*, *E*, *F*, *G*, *H*. Upon the axle *G*, and support *K*, rest the lever *I*, which is connected by cord *L*, to lever *M*. The pressure for lever *I*, and drawing-rollers *G*, *H*, is regulated by weight *N*.

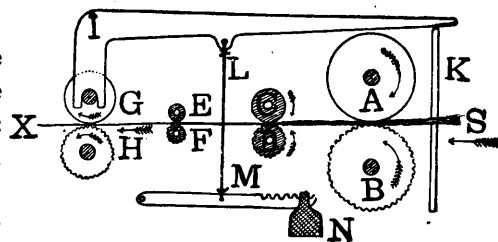


FIG. 291.

**Difference between the English and French System of Drawing and Spinning.**—Worsted yarn spun by the French system will appear more bulky and spongy compared to yarn of the same material and counts spun by the English system. The reason is found in the method of operation of each system. In the English system a constant stretching and flattening of the yarn is done, thus taking out nearly all the elasticity the material contains; whereas in the French process this is avoided. In the drawing process no twist is put in the slubbing, and the roving, after leaving the front-rollers, touches absolutely nothing until twisted in the thread. In reference to the English system of spinning, one feature in its favor is a greater production and less space per spindle, whereas in favor of the mule is the spinning of higher counts, as well, as previously mentioned, the more natural position of the material in the thread.

**Twisting.**—Worsted yarn is very frequently made in two, three or more ply yarns. This process is the same, and is also done on the same machine, explained for woolen yarn (see pages 150, 151).

**Genapping.**—Genapping, or Gassing, is the process to which some of the worsted yarns may be subjected, and has for its object the removal of all the loose fibres (nap) extending outside the thread. It is the same process as gasing for cotton yarns, explained on page 72. The yarn is rapidly wound off the bobbin onto a reel, and in its transit passes through a gas-jet, which slightly singes it. Great care must be exercised not to hurt the thread. Light or medium-colored yarns are generally genapped before dyeing, whereas dark colors can be genapped after dyeing.

## Silk.

Silk consists of the pale yellow, buff colored, or white fibre, which the silkworm spins around about itself when entering the pupa or chrysalis state. Silkworms are divided into two classes, the *Bombyx mori*, or mulberry-feeding worm, from the cocoons of which is reeled the ordinary raw silk, and the wild silkworms which feed upon certain kinds of oak, ailanthus, castor-oil plant, etc. The product of the latter specimens (amongst which the *Tussah-worm* is found, producing the *Tussah-silk*) was little heard of in this country and Europe until recently, and but for the outbreak of the silkworm disease in Europe the Tussah-worm which now gets more and more introduced there, would probably have remained in India and China, although it had been utilized in both these countries for many centuries. The date when the use of silk for textile purposes, was first discovered is not exactly known. Some of the Chinese historians claim that it was about 2,700 years B. C., whereas others only go as far back as about 1703 B. C. or the reign of *Hoang-ti*, the third of the Chinese emperors. He, the legend tells us, was desirous that his legitimate wife *Si-ling-chi* should contribute to the happiness of his people, thus charged her to examine the silk-worms and test the practicability of using the thread. In accordance with this wish, she collected insects and feeding them in a specially prepared place commenced her studies and examinations, discovering not only the means of raising them, but also the manner of reeling the silk and its use for textile purposes. It is claimed that even to the present day the empresses of China on a certain day go through the ceremony of feeding the silkworms, and rendering homage to *Si-ling-chi* as *Goddess of Silk Worms*.



FIG. 292

**The Mulberry Silk Worm.**—(see Fig. 292). The principal countries for carrying on the silk worm culture are Southern Europe, China, Japan, and India. In our country silk culture is only in its infancy, yet it is rapidly assuming considerable proportions.

The silkworm exists in four stages—*egg*, *larva*, *chrysalis*, and *adult*.

**Egg.**—The eggs, called by silk raisers the seeds, are about the size and shape of turnip seeds. One ounce will balance about 38,000 to 40,000, which have when first deposited a yellowish color which is retained if unimpregnated, but if impregnated, the same soon gets a gray, slate, lilac, violet, or dark green hue, according to the breed. If diseased it assumes a still darker tint. The eggs of some specimens are fastened by a gummy secretion of the moth to the substance upon which they are deposited, whereas other specimens (amongst which are the *Adrianople whites*, and the *yellows from Nouka*) do not have this natural gum. The eggs become lighter in color when approaching the hatching which is due to the fluid becoming concentrated in the centre forming the worm, leaving an intervening space between it and the shell which is semi-transparent. After the worm has left its shell the latter becomes quite white. The average production of each female is about 400 eggs. The color of the albuminous fluid of the egg is the same as that of the cocoon formed later, hence when the fluid is yellow the cocoon will be yellow, and again if white, the cocoon will be white.

**Larva.**—The silkworm remains in its larva state about six weeks, changing its skin four times during that period and abstaining from food (like other caterpillars) for some time before each change. When full grown the worm ceases to feed, shrinks somewhat in size, and *mounts*, *i. e.*, climbs up from the feeding tray to the bush, *echellette*, or whatever may have been prepared for it, and commences to form itself in a loose envelopment of silken fibres gradually enwrapping itself in a much closer covering forming an oval ball (*cocoon*), (Fig. 293) about the size of a pigeon's egg. The worm generally requires from four to five days in constructing the cocoon and then passes three days more in the chrysalis state (Fig. 294).



FIG. 293.



FIG. 294.

**Cocoon.**—The cocoon (Fig. 295) consists of two parts:—First, of an outer lining of loose silk, used for waste silk, and which has been spun by the worm in first getting its bearings, and second the inner cocoon, which being a strong and compact mass composed of a firm and continuous thread, which is not wound in concentric circles as might be expected, but in a short figure 8, resembling loops (Fig. 296) first in one place and then in another, hence in reeling, several yards of silk may be taken off without the cocoon turning around.

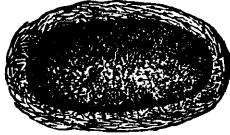


FIG. 295.

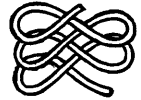


FIG. 296.

**Color.**—Chinese cocoons are usually white or yellow, varying from pure white to a pure lemon color, those of Japan are of a pale green color, and those of France, Italy and Spain are of a white or yellow color, or occasionally tinged with a pale green, whereas those of Broussa and Adrianople, being the best silk districts of Turkey, are of a pure white color.

**Moth.**—(See Fig. 297) As soon as the change of the worm into the chrysalis state is completed, which will be in about eight days from the time the spinning commenced, the cocoons are collected and such as are intended for breeding are put in a room heated to 66-70° *F*. After lying thus about fifteen days the silk moth has been formed in the interior of the cocoon, and which emits a peculiar kind of *saliva*, with which it softens one end of the cocoon and thus pushes its way out. The discharging of this saliva greatly injures the silk. A few days after the females have laid their eggs they die, not being provided with any organ of nutrition. The eggs are gradually dried and stored in glass bottles in a dry dark place till next spring.

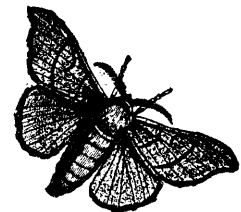


FIG. 297

**Introduction of the Silk Worm into Europe** dates back to A. D. 555, when two Nestorian Monks, who had been for some years missionaries in China, at the peril of their lives came across the Asiatic continent bringing concealed in the hollow of their pilgrim's staves a quantity of the choicest silk worm eggs, and which they delivered to the Roman Emperor Justinian I., revealing to him at the same time the entire process of silk culture, which they had carefully studied when in China. Emperor Justinian took a great interest in establishing silk culture in his Empire, putting the Nestorian Monks in full charge of his undertaking. Soon afterwards all over what is at present European Turkey, Greece and Asia Minor, silk culture became a favorite employment. At the downfall of the Eastern Empire (Twelfth Century) the knowledge of silk culture was carried by the Arabs and Saracen Princes to Northern Africa, Spain, Portugal and Sicily, and from there found its way to France, Venice and Genoa and gradually to Switzerland, Austria, Germany, etc.

#### Cocoons in Their Natural State Contain

68.2 per cent. Moisture,
14.3 per cent. Silk,
0.7 per cent. Floss (bourre)
16.8 per cent. Chrysalis.

---

100.—

**Polyvoltines.**—The best breeds of silkworms go through their changes but once a year, yielding in return large cocoons, and being of little trouble to the silk grower, whereas other breeds (apparently of the same species, but of the same genus) go through these changes two, three, four or more times a year, yielding in turn an equal number of crops of cocoons. These silkworms are classified as *polyvoltines*, such as yielding two crops are known as *bivoltines*; three crops as *trivoltines*, etc., etc. The silkworm yielding the greatest number of crops (8) is known as *dacey* and is found in Bengal.

**Stifling.**—As previously mentioned, after the cocoons are collected they are sorted; such as are intended for breeding are treated as previously explained, whereas those intended for commerce are subjected to the next process, that of *stifling*, or destroying the vitality of the chrysalis by steam. It consists in submitting the cocoons to a steam bath at a uniform temperature of 212° F., the steam rising practically uncondensed, under an iron receiver, which covers the cocoons. The chrysalides are suffocated by the diffused heat which penetrates thoroughly, while the web of the cocoon retains its natural condition. This method of destroying the vitality of the chrysalis was invented by Professor Castrogivanni, of Turin. The apparatus required for this consists of a basin connected by a pipe with a steam boiler, two circular plates running on rails on which the trays holding the cocoons are placed, a bell receiver, supported by two iron uprights, arranged by means of a pulley and counterpoise to permit an easy raising and lowering. The bell is provided with a thermometer and a stop-cock for letting off the air and steam when required. The method of procedure is as follows: Fill the basin partly with water (about 4 inches high), admit the steam to it and lower the bell, having the stop-cock open. Raise the temperature until the thermometer registers 210 to 212° F.; the cock must then be closed, not to be opened again during the operation. The bell is next raised to allow the plate on which the trays of cocoons are placed to be run over the basin, and then lowered again into the water until the edges are covered but not touching the bottom of the basin. In about fifteen minutes the bell is lifted, the cocoons which have been steamed are run off, and a second lot, which have been previously made ready, are placed on the plate and proceeded with as before. For perfect work care must be taken to maintain the internal temperature of the bell receiver at the same degree, hence the water must always be boiling, and a fresh supply regularly admitted to take the place of that evaporated in the steam. Although the killing of the chrysalis by steam does not damage the silk at all, as might be the case if using the older process; *i. e.*, killing the *pupæ* of the cocoon by means of heating the cocoons for about three hours in an oven heated to 145 to 155° F., yet the steam process has one serious defect—some of the *pupæ* may burst and soil the silk, and the fibres may soften somewhat, being apt to stick together and render subsequent reeling more difficult. In the warm Southern States the dry-heat choking can be accomplished by simple exposure to the sun. There the cocoons need only to be fully exposed to the rays of the sun from 9 o'clock in the morning until 4 o'clock in the afternoon. Two or three days of such exposure are sufficient, but, as sometimes strong wind can annihilate the effect of the sun's warmth, it is good to have for that purpose long boxes, 4 feet wide, sides 6 inches high, to be covered with glass frames. This will increase the heat and, by absorbing the air of the box, stifle the chrysalis most surely. Some silk raisers say that in the glass cover of the box a crack should be left open to allow the evaporation of the moisture, which otherwise would collect in large drops upon the glass and, falling back upon the cocoons, would keep them moist for a longer time. However, don't allow ants to creep in at the crack, as they will penetrate the cocoon to feed upon the chrysalis.

In the colder climates it has been suggested that the chrysalis could be well choked, with no injury to the cocoons, by placing them in a vacuum-box and exhausting the air. Chloroform has been used to a certain extent, and experiments are being made in France with sulphydric acid gas, also with bisulphide of carbon.

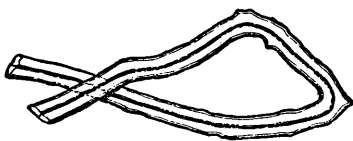


FIG. 298.

**Sorting.**—After destroying the vitality of the chrysalis, the cocoons are sorted into different grades, according to quality. In the best cocoons the silk thread as formed by the worm will measure from 1,000 to 1,300 feet, and though it appears to the naked eye single, it is in reality composed of two threads (see Fig. 298) which are glued together and covered as they issue from the spinneret of the moth with a glossy gum which enables the worm to fasten the silk where it wants it, and

which is soluble in warm water.

**Reeling.**—The silk as formed by the worm is so very fine that if each ball or cocoon were reeled separately, it would be totally unfit for the purpose of the manufacturer; in reeling, therefore, the ends of several cocoons are joined and reeled together out of warm water, which softening their natural gum

makes them stick together so as to form one strong thread. This process of reeling silk from the cocoons is very simple. The common reeling machine in use consists of a reel of sixty to ninety inches in circumference, the frame work containing the guides, the basins and means for heating the water therein. The cocoons are next stripped of their surrounding floss, being placed conveniently beside the reeler, who taking a handful puts them in the basin containing hot water, and by watching them soon ascertains whether the water is sufficiently hot or not, for if during reeling the cocoons lift from the basin, the water is not hot enough to dissolve the natural gum of the cocoon with sufficient rapidity; if on the other hand the silk comes from the cocoon in flakes, the water is too hot. After putting the cocoons in the basin filled with hot water, they are prior to reeling beaten with a small birchen broom (having the tips split so that the loose threads readily fasten to them) until the *floss* is gotten rid of and the true thread drawn from the cocoon. The reeler next seizes as many single filaments as he intends to convert into one thread, according to the quality of the silk wanted, and quickly passes them through the first guide. The same operation is simply duplicated by drawing the filaments from another equal number of cocoons through another guide. There are now two threads drawn from equal numbers of cocoons above the first guides, these are then brought together, twisted several times so as to form for a short space the strand as if it were a two-ply thread. The two minor threads again diverge, and being passed through the second fixed guides, and next through the distributing guides are attached to the *tambour*, which is kept revolving in a steady, rapid manner, and to which is also given a certain back-and-forth side motion. In some instances the twisting of the minor threads, as previously explained, is duplicated before passing the threads to the distributing guides. The object of thus twisting the minor threads is to deliver the same on the reel in a rounded form, well joined, properly free from moisture, and crossed on the reel so that they will not stick or glaze; if otherwise, these minor threads, being as before explained in a soft condition, would in passing the guides not only assume a flat shape but also obtain an undesirable roughness. The silk reeler must be very careful throughout his entire work, for he must keep the silk thread of a uniform size. For example, let him start his work with five cocoons or minor fibres to one thread; the filament of each of these five cocoons gradually becomes more and more attenuated, the nearer it approaches the chrysalis, and to be able to balance the required count of the thread by adding the filaments of other cocoons is a very particular work. These five cocoons, with which the reeler started, may sometimes have to be increased to six, seven, eight or more cocoons and this without altering the counts of the silk thread when on the reel. Another point, which makes reeling rather a difficult procedure is, that no two of the same breed of worms will spin just the same amount, and between cocoons of different breeds or those spun under different circumstances, the length varies from 300 to 1,300 yards. The person doing the work must be careful not to reel too close to the chrysalis, as such silk is inferior in quality as well as color. Double cocoons, soft cocoons, imperfect cocoons, and diseased cocoons, can never be reeled completely and frequently not at all. Double cocoons can only be reeled by means of boiling water, which would hurt good cocoons.

Good reeling is of the greatest importance to the manufacturer, which is clearly demonstrated by the fact that Italian raw silk, even at an advanced price, is more economical for him to use compared to a similar quality of Chinese silk, but which is generally of a poorer reeling.

**Silk Reel.**—To illustrate the process of silk reeling, Figs. 299, 300 and 301 are given. Fig. 299

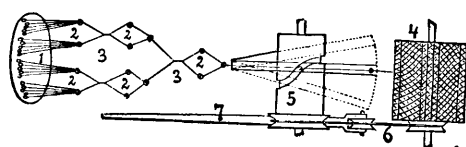


FIG 299.

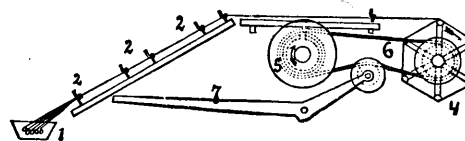


FIG 300.

illustrates the plane and Fig. 300 the corresponding section of what is known as an old *French reel*, but which embodies the principle of any reel used nowadays in an improved reeling establishment. Numbers of references in both drawings are selected accordingly. 1, Water basin, which may be heated by

steam or a charcoal furnace. 2, Guides for the threads. 3, Position in which the threads are twisted to clean their surfaces and to give them roundness. 4, Reel or tambour. 5, Cylinder (on shaft) having a spiral groove in its surface, in which a pin fits from the transversing bar, hence giving the lateral movement to the thread, which goes through a guider on the front end of the bar, moving through the arc of a circle. 6. Connection of reel to the cylinder for transmitting motion to the former. 7. Friction lever, for tightening or slackening the endless cord or belt which transmits the power from the cylinder to the reel. Diagram Fig. 301 shows an improved Lombardy hand reel (constructed on about the same principle as the French reel), set up and ready for work. 1, Water basin, to be heated by a charcoal fire. The basin fits tightly over—2, the square tin tray which holds the cocoons, etc. 3, Short stick inserted in a holder 3', on which the ends of the cocoons are wound, so as to be ready for use. 4, Cock, for drawing the water from the basin every night after use. 4', Door to furnace, lined with fire brick, wherein the charcoal fire is lighted to heat the water in the basin. 4'', Flue pipe for carrying the charcoal fumes either into a chimney or into the open air. 5, Guides for the threads from the cocoons, through these guides the threads pass to and over the pulleys or rollers 5'', revolving on bent wire stands. The guides must be placed in such a position that the threads pass upward in a straight line from the water in the basin to the pulleys, and from there to the top of the wheel (except

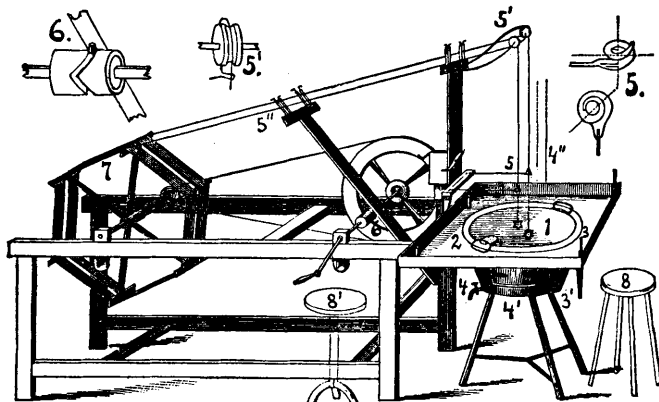


FIG. 301.

when diverted laterally by the long guider at 5''), friction being in consequence reduced to a minimum, and the elasticity of the thread preserved. 6, The grooved arrangement, by means of which the long guider working to and fro distributes the thread to the reel on the required *cross* or *lease*. 7, The reel or *tambour*, which has one of its arms supplied with a screw-hinge, by means of which the length of the arm can be diminished to take off the silk. 8, Stool, on which the adult reeler sits, being in front of the cocoons, whereas the child, or whoever turns the crank

for operating the machine, takes his place on the other stool 8'. (For illustrating parts 5, 5' and 6, drawings in detail are given.) In larger reeling establishments there are usually several of these reels in one room and driven by power, but each is arranged so that it can be stopped when necessary without disturbing the others. If the motive power in the establishment is steam, suitable arrangements can easily be made by means of pipes and stop-cocks to heat the water in every basin instantly or gradually by steam.

**Improved Silk Reel.**—A most ingenious method of reeling silk has been lately patented by a Mr. Serrell in this country, France, Austria, Germany, Italy, Spain, Sweden, and Portugal. As mentioned previously in this chapter on silk reeling, the filament from a cocoon is coarsest at the outer end, and becomes finer toward the inner end, hence the operator must add a fresh filament from time to time to the thread, so as to keep the latter uniform. This operation requires very close attention, as well as experience, on the part of the operator. The object of Mr. Serrell's invention is to gauge the thread during the process of reeling, and to supply to it automatically additional filaments, as it becomes weaker in consequence of a cocoon becoming exhausted, or of the diminution in size of the filaments, thus maintaining for the thread the greatest possible uniformity in size and strength for the thread as reeled. Fig. 302 is a side view, partly in section, of the silk-reeling machine, with the floor upon which the machine rests, also in section. Fig. 303 is a plan view of a portion of the table, the water basin, a pair of cocoon holders, feeding drums, and filament attaching devices, with pulleys and belts for rotating the drums and filament-attaching devices. Fig. 304 is a sectional eleva-

tion of the parts shown in Fig. 303. Fig. 305 is a diagram illustration of the electric devices and connections of the apparatus. Fig. 306 is a sectional plan, showing the ratchet-wheel upon the shaft

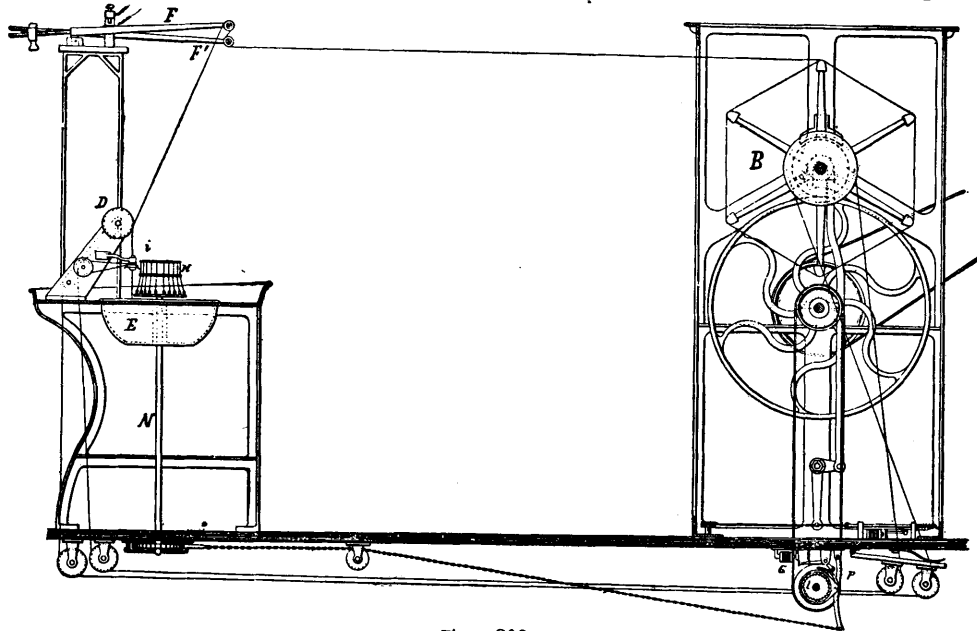


FIG. 302.

of the cocoon-holder, and the devices at one end of the chain for turning said wheel and shaft. In practice two threads are wound upon the same reel, hence two cocoon-holders and two sets of apparatus, in conjunction with each basin and with one reel, are used; but as these are similar only one is described. In most of the reeling establishments there are several basins, side by side, each being provided with two sets of devices, as previously alluded to, and the reels for each set of devices are situated in a frame common to all, with but one driving shaft to rotate all the reels. Letters of references in all four illustrations are selected to correspond.

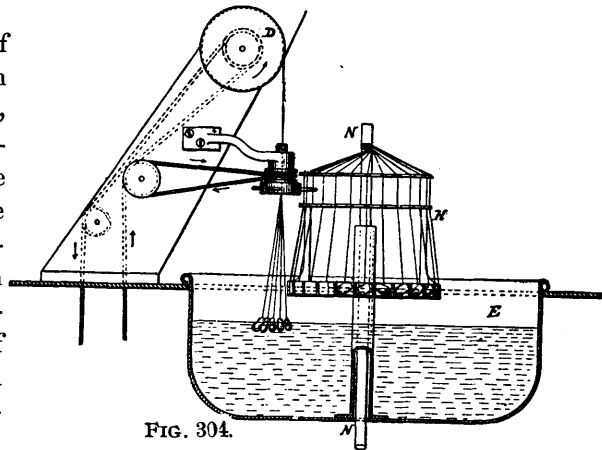


FIG. 304.

The operation of the machine is as follows: The operator places a cocoon in each compartment of the cocoon-holder or magazine *H*, and leads the filaments of each of the cocoons up over the upper plate, attaching them in any convenient manner, as shown in Fig. 304. The filaments of several other cocoons are then passed through the attaching devices, or cylinder, *i*, to form the beginning of a thread. The thread thus formed is passed one or more times around the feeding drum *D*, so as to secure sufficient adhesion to prevent slipping, and the thread, after making the *croisure* (crossings), is carried over the small pulley at the end of the lever *F*, and under the pulley at the end of the lever *F'*, and thence to the reel or tambour *B*. The counter-weight of the

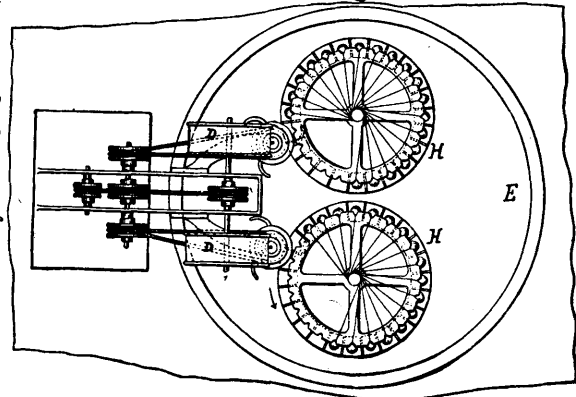


FIG. 303.

lever  $F$ , is adjusted by trial to the position required for the size of silk which it is desired to reel, and the reel is allowed to revolve. The thread is delivered from the drum  $D$ , at a speed about five per cent. less than that at which it is wound in by the reel  $B$ , which will result that in the process of winding, the thread is uniformly stretched this per centage or a fixed proportion in relation to its length, being the proportional difference in winding speed between the drum  $D$ , and the reel  $B$ . The passing thread thus stretched acts upon the lever  $F$ , with a force which varies according to the strength of the thread to resist the elongation. Now the force which is required to stretch a silk thread a given proportion in relation to its length is practically in direct proportion to its diameter, and from this it follows that the

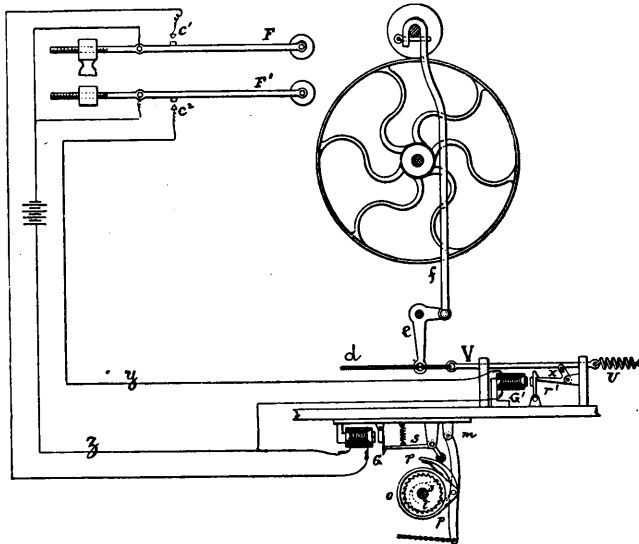


FIG. 305.

forces tending to depress the lever  $F$ , being in proportion to the resistance to elongation are proportional to the size of the thread which is passing at any given moment. The lever  $F$ , having been adjusted for the desired size of silk, is held down at the end nearest the reel as long as the passing thread is sufficiently strong, and therefore of the required size; but as soon as the thread becomes too weak, the resistance diminishes and the lever  $F$ , rises and touches the contact point  $c'$ . An electric circuit is thus closed, and the magnet  $G$ , attracts its armature, releasing the latch-lever  $S$ . The spring now causes the pawl  $p$ , to engage with a tooth of the ratchet-wheel  $l$ , and the cam-case  $o$ , begins to make a revolution. This allows the spring  $T$ , to contract, causing the ratchet-wheel  $X$ , to advance one tooth through the action of the pawl  $t^2$ . The shaft  $N$ , revolves with the ratchet-wheel  $X$ , sufficiently to advance the magazine  $H$ , by one compartment, because the magazine contains the same number of compartments as there are teeth in the ratchet-wheel  $X$ . In thus partly revolving the cocoon holder  $H$ , brings a cocoon filament within reach of one of the hooks upon the rapidly revolving cylinder  $i$ . The filament so brought within reach is seized by the hook, and the revolution of the latter causes the newly-caught filament to be wrapped around those which are already paying out at a point between the lower end of the cylinder  $i$ , and the water in the basin  $E$ . The filament so wound around the running thread adheres because of the glutinous matter with which heated and wet cocoon filaments are naturally coated, and becomes attached to and a part of the thread being reeled. The thread being thus strengthened, is usually of sufficient size, and, in consequence strong enough to draw down the end of the lever  $F$ , and break the electric circuit before the cam-case  $o$ , has completed its revolution with the shaft  $J$ . When this is the case, the lever  $F$ , no longer touches the contact-point  $c'$ , and the magnet  $G$ , not being excited the hook of the armature retains the latch-lever  $S$ , and the pawl  $p$ , being withdrawn from the teeth of the ratchet-wheel  $l$ , the filament-supplying mechanism comes to rest until the thread becoming again weakened, the operation is repeated and another cocoon filament added. Should however, the first cocoon not be sufficient, or should the cylinder  $i$ , fail in seizing and attaching it, then the lever  $F$ , is not drawn down, the contact remains closed at the point  $c'$ , and the cam-case  $o$ , continues to revolve, thus progressively advancing the magazine and causing to be added as many cocoon filaments as may be

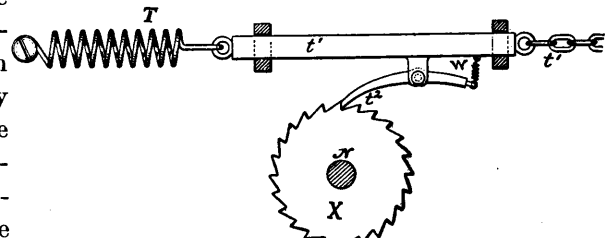


FIG. 306.



necessary to bring the thread up to the desired strength and size. The lever  $F^1$ , is used in combination with the magnet  $G^1$ , the armature  $r^1$ , the lever  $x$ , the spring  $U$ , the slide-rod  $V$ , to stop the reel when the thread breaks, and the operation of the device is as follows: As long as the thread is unbroken the lever  $F^1$ , is held up and does not touch the contact-point  $c^2$ ; but as soon as the thread breaks, the lever  $F^1$ , falls and makes contact at the point  $c^2$ . The electric circuit is completed through the magnet  $G^1$ , and the wires  $y, z$ . The magnet  $G^1$  is thus excited, and the armature  $r^1$ , is attracted, thus releasing the lever  $x$ , allowing the spring  $U$ , to lift the friction-wheel of the reel off from the main friction-wheel by means of the rod  $V$ , lever  $e$ , and rod  $f$ . This causes the reel  $B$ , to stop. To put the reel in motion, the cord  $d$ , is drawn upon by means of a pedal, or otherwise, which again latches the armature  $r^1$ , and moves the lever  $e$ , and this extends the spring  $U$ , and allows the friction-wheel of the reel to bear upon the main friction-wheel which is constantly in motion.

This silk as it leaves the reel is known in commerce as *raw silk*, and it is determined to a great extent by its fineness and regularity of thread, its clearness or freedom from knibs, or particles of skin and badly attached filaments. Its counts are not judged entirely by the eye, but by weighing a certain length of thread. The adopted custom of specifying the size of silk yarns is in giving the weight of the 1000 yards hank in drams avoirdupois, except in fuller sizes where 1000 yard skeins would be rather bulky and apt to cause waste. Such counts are made into skeins of 500 and 250 yards length, and their weight taken in proportion to the 1000 yards. In Milan (Italy) a most complicated slow process of silk reeling is practised, allowing the thread to dry, and passing it direct from the distributing guides to the throwing machinery which at once puts the first twist into the threads and also delivers them to a bobbin in the form of *singles*.

**Raw Silk.**—(*i. e.*, Reeled Silk)—Constitutes the raw material for the American silk manufacturer. When imported the same generally comes in picul bales of one hundred and thirty-three and a third pounds. Such as come from China are made up in bundles weighing from eight to twenty-five pounds each and are protected at the corners by floss or waste. The Italian silk comes in bales made up of skeins. Before it reaches the loom this raw silk must pass several manipulations and processes. First the same is taken to the sorting-room, and the various sizes of thread or, in other words, the different degrees of fineness, are assorted each by itself. The next process is the transferring of the silk from the skeins (which are of irregular length) to the bobbins. A parcel of skeins enclosed in a light cotton bag is soaked in water having a temperature of 110°F. for a few hours so as to soften the gum. After taking these bags out of the water they are submitted for from 5 to 10 minutes to the action of a hydro-extractor to liberate the superfluous water and the silk with its gum, thus sufficiently softened is ready for winding. The skein is stretched upon the *swift* or light revolving frame for holding it, the thread passes through the traversing guide onto the bobbin which rotates on a horizontal axis and receives its motion by means of a small roller fastened on the bobbin spindle. This spindle is placed in two grooves, and also is parallel to a light shaft bearing at one end a metal wheel, the friction of which conveyed by the little roller gives motion to the bobbins. A face cam gives motion to the traversing guides calculated according to the length of the bobbin. The next manipulation the silk thread undergoes is cleaning.

**Cleaning.**—In this process the silk thread is simply transferred from one bobbin to another and passes during the transfer through the cleaner, which consists of two sufficiently close parallel plates to catch any irregularity upon the silk, and at the same time arrest the motion of the spindle until the operator removes the cause. Fig. 307 illustrates the principle of the cleaning process. The bobbin  $A$ , containing the silk is unwound and the thread  $B$ , passed over the rod  $C$ , and the cleaner  $D$ , which is fixed in guide-rail  $E$ . The thread  $B$ , is wound upon the bobbin  $F$ , which is turned by friction roller  $H$ . Chinese silk always requires cleaning, whereas Italian silk does not usually require this cleaning.

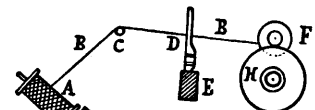


FIG. 307.

**Doubling.**—The third process is doubling, which is done by means of the doubling machine, and consists in bringing two or more single threads from two or more bobbins side by side onto one bobbin but without any twist.

**Twisting or Spinning.**—The fourth manipulation of the silk thread is accomplished on the spinning machine. The latter puts a twist into the two threads which the doubling machine brought already together. In finer counts the third process is omitted, hence the twisting machine is also used to put twist in a single thread.

**Take-up Attachments for Doubling, Twisting or Spinning.**—Lately a most ingenious device for machines used either for doubling, twisting, or spinning, has been patented by a Mr. Conant providing said machine with take-up attachments combining the functions of taking up the slack produced by stopping the machine, placing the silk under perfect control as to its tension. Fig. 308 is a transverse section view of the invention.

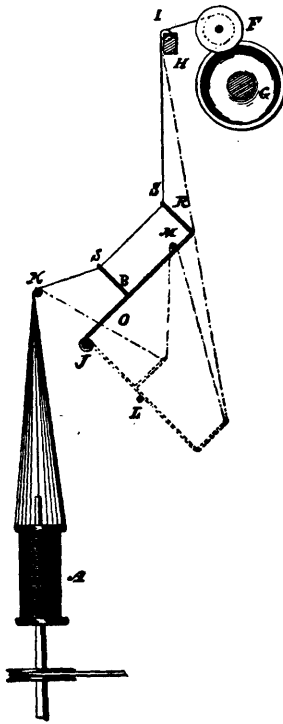


FIG. 308.

The silk is led from the feeding bobbin *A*, over the supporting and guide-wire *K*, then through the hook *S*, of the arm *B*, of the take-up, then through the hook *S*, of the arm *R*, of the take-up, then over the distributing roller *I*, revolving in frame *H*, and thence to the receiving bobbin *F*, which is turned by means of friction with pulley *G*. When the machinery is in motion the bobbins rotate at a very high rate of speed imposing sufficient tension on the silk passing from the feeding to the receiving bobbin to support the take-up in a normally elevated position, in which, however, it exerts a constant tendency to drop down and draw the silk down on opposite sides of the combined lift-detent and silk-supporting wire and below the silk supporting and guiding wire in the form of two long independent loops, so that any fluctuations in the amount of silk thrown from the feeding-bobbin or wound upon the receiving bobbin will be automatically met and compensated for by the dropping of the take-up, whereby the virtual distance between the two bobbins will be increased exactly in proportion to the amount of slack to be taken up. This action of the take-up not only preserves the silk at a uniform tension, but also prevents it from snarling. When the frame is stopped, the feeding-bobbin, by reason of the inertia acquired when it is running, does not stop the moment the power is cut off, but makes a few turns and throws off a few coils of silk before its inertia is overcome. The slack so produced is at once taken up or absorbed by the take-up, which drops virtually into the position indicated by the broken lines in the illustration where it is shown as resting upon the drop-detent wire *L*, which prevents it from swinging so far under the carrying-wire as not to be readily lifted again by the strand. It will be noted that when the take-up

is in this position the virtual distance between the two bobbins is very largely increased. When the machine is started again, the tension imposed upon the strand by the receiving bobbin at once operates to lift the take-up to its normal position, the lift-detent wire *M*, preventing it from being lifted too far or to a point from which it will not readily fall back. By taking up, as described, the slack produced by stopping the machine, the product of the operation will be free from knits and kinks.

In case the silk breaks, the take-up at once drops onto the drop-detent wire *L*, and so indicates to the operator the breakage, which is difficult to detect without some such visual signal, especially if the light is not good, or by artificial light, on account of the extreme fineness of the silk in this stage of working.

The spinning machine also resolves the silk into the specific terms *tram* and *organzine*.

**Tram Silk** is made by twisting two or more single untwisted threads, which are then doubled and slightly twisted. The object of tram silk is to form simply a heavier count, and the product is chiefly used for filling.

**Organzine Silk** is produced by the union of two or more single threads twisted separately in the same direction, which are doubled and then re-twisted in the opposite direction. Organzine silk is chiefly used for warp.

**Silk Throwing** (from the Saxon, *throwan*, to twist) is the technical term used for winding, twisting, doubling and re-twisting raw silk, as the case may require, either for tram or organzine. The person doing this work is called a throwster.

**Single Silks.**—In some fabrics, for example, *pongees*, the silk yarn is used without doubling or twisting, or is used in its single state; *i. e.*, after leaving the second process of cleaning, which has been already explained. Such silks are known as *singles*, and produce a cloth which possesses (after being bleached and dyed) a softness and brilliancy unattainable with silk which has been twisted; *i. e.*, tram or organzine. This point will readily demonstrate the advantage of not imparting to silk any more twist than is absolutely necessary on account of the scouring, dyeing and weaving processes.

**Scouring.**—The next process which silk undergoes before dyeing is scouring. As previously mentioned, silk contains a large amount of gum or saliva, which the silk-worm spins into the single thread; also other impurities, which have been necessarily added in throwing it, and which all have to be removed, although in some silks this is less fully done. According to the quantity of saliva removed, the different processes of scouring are called, *boiled*, *souple*, and *ecru*.

**Boiled-off Silk.**—This scouring or ungumming of silk is performed by means of soap solutions, heated to about 195° to 205° F. Boiling silk repeatedly in these soap baths deprives the silk of its gum or saliva, and the same acquires the softness and lustre so highly prized in silk fabrics. In the process the silk will lose from 24 to 30 per cent., according to the class of raw silk used; China silk losing the most and European and Japanese silks the least. These soap baths as used for boiling-off silk are utilized as much as possible, and afterwards worked up for the recovery of the fatty acids by treatment with sulphuric acid. These soap-suds are also very useful as an addition to dye-baths when dyeing silks with aniline colors.

**Souple Silk**, is silk which only lost from 5 to 8 per cent. of its weight, and consequently is in scouring only partly deprived of its gum or saliva.

**Ecru Silk**, is the fibre deprived of its gum to the extent of from 2 to 5 per cent. by washing in weak soap-suds and afterwards sulphuring.

After the silk has been thus scoured, it is ready for dyeing. For white, and also very delicate bright shades, the silk is bleached before dyeing in an air tight room in which sulphur is burnt.

**Shaking, Glossing and Lustreing.**—One of the most important physical properties of silk is its lustre, and in order to develop this feature to its maximum, silk is submitted, after scouring, bleaching or dyeing, to either one or the other, or to all of the various processes known as shaking, glossing or lustreing. The *shaking process* is to open out the hanks and remove all chance for curling of the threads. It is generally done before the yarn (after being dyed or scoured) gets perfectly dry, since dampness will greatly facilitate the process. It may be performed by machine or hand. In the latter instance after extracting all superfluous water by means of an hydro-extractor, (see Fig. 309) a strong and perfectly smooth wooden peg is fixed to the wall, and a hank of silk yarn hung on it. A wooden stick is next inserted in the loop of the hank of yarn and the latter is quickly and forcibly pulled, the operator taking care to frequently change the position of the hank. After one hank is finished, it is taken from the peg, a fresh one substituted, and the operation repeated. *In glossing*

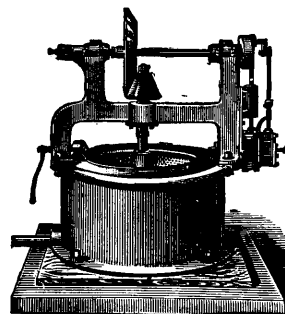


FIG. 309.

also called *stringing*, the silk is operated upon when dry. This process is of great importance especially with souple silks with which it forms the last operation before winding and weaving. The main feature is to twist the hanks of silk when dry, and can either be done by hand or by means of stringing machines.

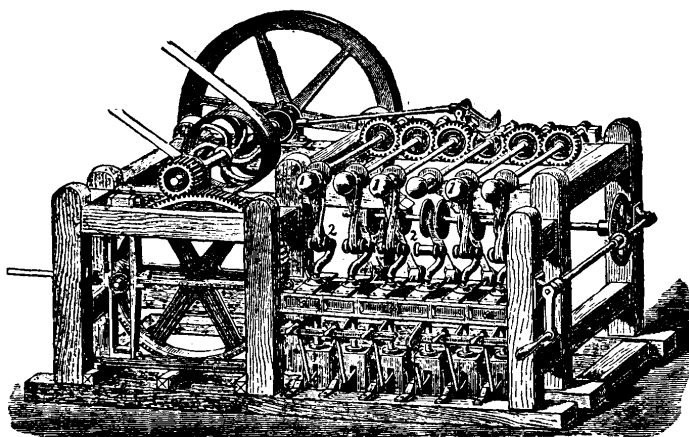


FIG. 310.

The hand process closely resembles the previous process of shaking, the only difference being that instead of pulling the hank of yarn, it is twisted as tightly as possible, and left in this condition for several hours, the operation being frequently repeated for several days. A *silk stringing machine* is shown in Fig. 310 and consists of a series of pegs placed horizontally (see 1) on each of which a hank of yarn is hung which is fastened below to the corresponding peg of another series of horizontal rollers (see 2). Pegs indicated by 1 revolve by means of a lever, ratchet and cog-wheel arrangement; whereas the lower rollers are capable of two movements, first revolving on the

axis and then at right angles to this. Each spindle is also arranged to permit its sliding up and down. The movements for the hanks of silk yarn are thus automatic, and several repetitions of twisting, re-twisting and corresponding changes in position for the hanks completes an operation whose sole object is to increase the lustre of the silk. That operation by which the maximum of lustre upon silk is effected is termed *silk lustreing*, and is done by means of the *silk lustreing machine* as shown in Fig. 311. During the operation the silk is subjected to an easy tension between two polished steel rollers which revolve in the same direction and are enclosed in a cast-iron box. The necessary amount of stretching the yarn is effected by drawing the right hand rollers away from its corresponding stationary one by means of a hook worked by cog-wheels. While the steel rollers revolve in the same direction, steam at a moderate pressure is introduced.

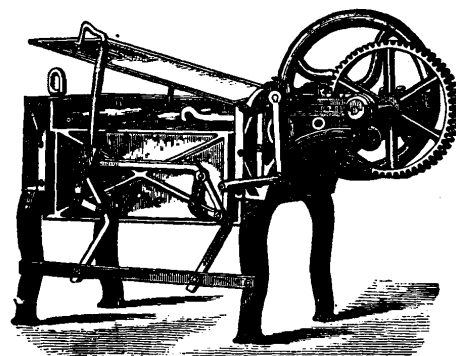


FIG. 311.

**Weighting of Silk.**—This manipulation of silk has recently acquired quite a strong hold in the silk industry. In silks for ribbons, and broad silks, double weight is frequently given to the fabric, while in silks used in the manufacture of fringes up to four times the original weight is thus obtained. The silk threads acquire during this manipulation a heaviness in their counts which they really have not, hence it is easy to deceive the buyer who judges the article by its general appearance and handling. Prof. Sansone gives the following very interesting matter regarding this subject of weighting silk. "The charging of silk, which by some has been recognized as an art, has been the cause of injuring the prosperity of the industry very considerably, and this beautiful fibre which in olden times was the symbol of strength and durability, is now-a-days simply the emblem of the hollow and presumptuous show in which this age heartily delights. I do not think that modern chemists need after all to be so proud of their achievement in this direction. It must be owned however, that in recent times attempts have been made to atone in a certain sense, by introducing methods of weighting silk which should not be injurious to the fibre. The methods mostly employed for this process rely on the selection of ingredients according as the silk is white, light, or heavy colored. Sugar and glucose were at one time the favorite products for sophistication, but the weighting cannot be made very high, and accordingly

the ingredients though harmless are not now in favor. For white and light colors, stannic chloride solution is employed, which is made up to 35–45° Tw., the silks being immersed, lifted out, wrung, and finally washed in a boiling soap and soda bath; each treatment increases the weight about 8 per cent. and is repeated according to the amount of weighting required. Silks so charged are easily deteriorated by long exposure to the sun-light. For dark shades, and especially for blacks, the ferric hydrate or peroxide is the weighting mostly employed, in the shape of the old and well-known iron mordant, for silk the nitrate or persulphate of iron, which is prepared from copperas by the addition of sulphuric and nitric acids. The application relies on the employment of this liquor made up to 45° Tw. or 25° Tw., according as it is a boiled or a souple silk. After remaining in this liquor long enough to thoroughly impregnate it, the silk is lifted out, wrung, then washed, and finally passed through a tepid soda bath, and soaped at the boiling point; every time the operation is repeated the weight is increased about 10 per cent. Silks so charged are generally employed for blacks; the iron charge does not deteriorate the fibre so readily as the stannic chloride, but the silks have a tendency to ignite spontaneously, and this has been the cause of fires on board of ships carrying these heavily charged silk goods. Tannins are also largely used for weighting silks, and they do not act so injuriously on the strength of the fibre as the metallic charges do, but they can only be employed for dark colors. Special tannin products artificially purified or bleached, have however, been introduced of late which allow tannins to be employed even with some lighter colors.”

**Silk-Conditioning.**—Silk kept in a humid atmosphere is capable of absorbing 30 per cent. of its weight of moisture without being noticeable in its general appearance. The high price of raw silk will make it of the greatest importance for the manufacturer to have the means of detecting the exact amount of moisture in any lot of raw silk offered for sale. For this reason so-called *silk-conditioning establishments* are to be found in the centres of silk industry all over the world, whose business it is to ascertain the amount of moisture in lots of silk given for testing. The apparatus used for the purpose is called the *dessicator*. The average loss of weight; *i. e.*, moisture found, is, as already mentioned, 30 per cent., but absolutely dry silk is not calculated as the basis or standard article; this is raw silk, containing 90 per cent. dry silk and 10 per cent. moisture.

**Chemical Compositions.**—The chemical compositions of silk, according to Prof. Mulder, are:

	<i>Yellow Italian</i> Silk.	<i>White Levant</i> Silk.
Silk fibre.....	53.35	54.05
Matters soluble in water.....	28.86	28.10
“ “ “ acetic acid.....	16.30	16.50
“ “ “ alcohol.....	1.48	1.30
“ “ “ ether.....	0.01	0.05
	100.00	100.00

Examining in detail the substances which each solvent had extracted, he obtained the following results:

	<i>Yellow Italian</i> Silk.	<i>White Levant</i> Silk.
Silk fibre.....	53.37	54.04
Gelatin.....	20.66	19.08
Albumen.....	24.43	25.47
Wax.....	1.39	1.11
Coloring Matter.....	0.05	0.00
Resinous and fatty matter.....	0.10	0.30
	100.00	100.00

**Waste Silk**, is all silk obtained from cocoons in any way soiled or unable to produce a continuous thread; also the extreme outer and inner portions of every cocoon. This waste silk is washed, boiled with

soap and dried, and is afterwards carded and spun like cotton, producing a silk yarn technically known as *spun silk*. The grading of these yarns according to the size is not the same as the raw silk, but is the same system as is used for cotton, with the exception of two or more ply yarns. Another kind of silk made from waste silk is *shappe silk*, which is manipulated the same as spun silk, except that the silk is not previously boiled.

**Wild Silks.**—The most important of them is Tussah, being the product of the larva of the moth *Antheraea mylitta*, and is principally found in India. This silk has until lately been greatly neglected, but at present commences to attract great notice. The cocoons are larger than those of the *Bombyx mori*, have the shape of an egg, and are of a silver-drab color. The outside silk of the cocoon is slightly reddish, and consists of separate fibres of different lengths, while the remainder of the cocoon is generally unbroken to its centre. Its fibres are somewhat glued together by a peculiar secretion of the worm, which permeates the whole wall of the cocoon, imparting to it its drab color. Fig. 312 shows the microscopic appearance of the tussah silk fibre. Tussah silk is bleached before dyeing delicate and bright colors. The process invented by M. Tessiè du Montay is the most frequently used. The agent used in this process is barium binoxide, from which free baryta hydrate is first removed by washing the binoxide in cold water. A bath is next prepared containing binoxide in proportions from 50 to 100 per cent. of the weight of silk to be bleached. The silk is afterwards washed in this bath, which is heated to 175° F. for about one hour, and in succession passed into dilute chlorhydric acid and washed again. If the silk does not become a clear white the operation must be repeated, or we may also complete the bleaching by scouring the silk in a solution of potassium permanganate and magnesium sulphate, and afterwards in a solution of sodium bisulphite, to which hydrochloric acid has

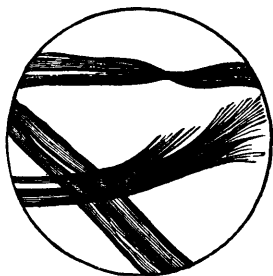


FIG. 312.

been added. Great care must be used during this operation not to leave the silk longer than necessary in contact with the barium binoxide, as otherwise it becomes dull, harsh and tender. Another agent for bleaching silk is hydrogen dioxide. The silk is steeped for several hours in a dilute and slightly alkaline solution of commercial hydrogen dioxide, and afterwards is well washed; first with water acidulated with sulphuric acid, and afterwards with water only. Another kind of wild silk is the one derived from the *Antheraea yamamai* of Japan. The cocoon of this silk-worm can be reeled with great facility; hence it is of great importance, for though some of the Indian wild silks are reeled by the natives, the process is tedious and very slow, and thus it is hopeless to expect any large quantity of reeled silk from there. In India the report

compiled by that government give particulars of no less than thirty-six varieties of wild silk-worms feeding upon different forest trees and shrubs. Chief among these are mentioned the *Antheraea paphia*, found in the jungles all over India, Burmah, and Assam. *Antheraea Perui*, an oak feeder. *Antheraea Assami*, or moonga, described as a very excellent silk-producer, which feeds upon the mango as well as the mulberry, and whose larva produces a large, fine and easily-reeled cocoon, of a medium light color being one of the best, if not *the* best, of the wild varieties. *Attacus Atlas*, the largest of the silk-producers. *Attacus Cynthia*, or the *Ailanthus* worm, feeds on the *Palma Christi*, or castor-oil plant, and is found in Nepaul, Mussooree, Java, and is now also reared in this country, Europe, and Australia; its silk is of a fair quality, but hard to reel, and generally used as waste silk (for carding and spinning purposes). The thread produced from it is rather coarse, but very durable. *Attacus Ricini*, the castor-oil plant feeder of Assam, which is claimed to be easily reared and to produce a good, light-colored silk.

**Wild Silk Compared to Silk Produced by the Bombyx Mori.**—Wild silk is distinguished from the silk of the *bombyx mori* by the longitudinal striations seen in each of the double fibres when under the microscope, and by the apparent contraction of the fibre at certain points. The former are due to the fact that the wild silk fibre is composed of a large number of fibrils, while the latter appearance is seen because more or less flattened fibres are twisted at the contracted points.



No. of Days of Crop.	Ages.	DEVELOPMENT.—Continued.	Temperature.	No. of Meals a Day.
28	1st Day		70° to 80°	5
29	2d "			6
30	3d "			7
31	4th "			7
32	5th "			7
33	6th "			8
34	7th "			8
35	8th "			4
		FIFTH AGE.		
		COCOONS.		
		CHRYSALIS.		
		FRONT.		
		MALE.		
		MOTHS.		
		FEMALE.		
		PROFILE.		



## Flax.

The flax plant is divided by botanists into four distinct species, of which the common (annual) flax *Linum usitatissimum* has been cultivated from the earliest times. It is yet growing wild in some parts of Asia and in Egypt. In Europe it is extensively cultivated; the time of sowing is between February and April, and the harvest season varies between June and September, whereas in Egypt it ripens under cultivation in the winter. The flax plant grows to a height of from three to four feet, and its stem branches more or less according to the thickness it is planted, *i. e.*, to the degree to which it is crowded by the other plants. The stem of the plant consists internally of the woody shore or boon which must be decomposed and removed; externally of a layer of bast fibres encased in a fine outer skin or membrane, being the fibre from which *linen* is made.



FIG. 313.

When the flax attains its full growth and approaches maturity, its tall and elegant stems of a soft green hue are surmounted by a corona of delicate branches, each branch supporting a bright blue flower. Fig. 313 illustrates flax as planted for fibre, *i. e.*, thick seeding. Fig. 314 shows the flower, Fig. 315 the seed-boll of flax (*a*, un-cut, *b*, cut through). Fig. 316 shows the flower cut lengthwise through the centre. There are five outer leaflets of the flower, all ovate and with a slightly hairy covering, and almost as long as the capsule. The stamens are alternate with the petals, and have their filaments united near their base in a circular form. The ovary is divided into five vesicles surmounted by corresponding stigmata, the capsules being egg-shaped and having a slightly pointed apex. Each of the five cells is sub-divided into two (and within these the seeds are secreted) making ten in all. These seeds vary slightly in shape, according to different conditions of growth; but those which are slightly oval, smooth and brown in color, approach nearest to a perfect form. An internal examination of the seed shows them to be white, with the kernel oleaginous and farinaceous, while the external surface has



FIG. 314.

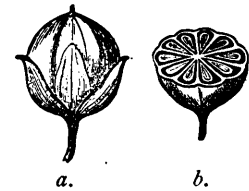


FIG. 315.



FIG. 316.

a viscous covering soluble in water. As previously mentioned, the flax plant also grows wild, closely, but on a reduced scale, resembling the cultivated specimen. The wild flax plant never exceeds a height of about eight inches, hence is of no use for textile purposes.

Fig. 317 illustrates flax magnified.

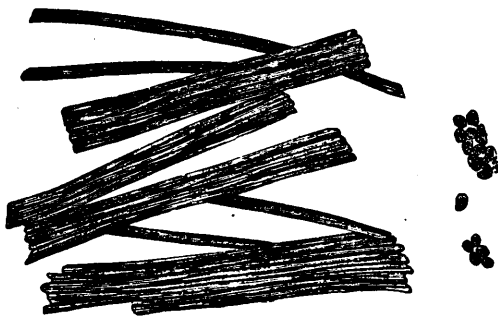


FIG. 317.

**Chemical Composition of Flax.**—The flax plant is chemically composed of:

41.97 per cent. Organic matter,  
56.64 per cent. Water,  
1.39 per cent. Ash.

**Pulling of Flax.**—The farmer who aims at the production of a good fibre, must pull the plant before it has attained its full maturity; namely, when the lower portion of the stalk, to the extent of

two-thirds of its height, has become yellow, and while the bolls or seed capsules are just changing from green to brown. At this stage the plants are pulled in handfuls, and these are laid across each other diagonally until a *sheaf* is complete, when the whole is carefully bound. If the plants are left in the ground until fully ripe (*i. e.*, the whole stem yellow) the fibre afterwards obtained will be stiffer and coarser. In finding stems of a different length, each should be pulled separately and kept in separate sheafs, as should also stems prostrated by the wind or saturated with rain.

**Rippling.**—The next process to which the freshly pulled flax is submitted is *rippling*, which has for its object the separation of the bolls from the stems. Flax should be rippled as soon as pulled, and the process be carried on in the same field. The *ripple* is a kind of large comb composed of iron teeth about eighteen inches long, made of half-inch square iron teeth placed  $\frac{1}{8}$  of an inch apart at the bottom and tapering slightly toward the apex, screwed down to the centre of a nine-foot plank, resting on two stools. This comparatively great length and smallness of the iron teeth allows them to spring lightly, and so yield to pull of the stalk, instead of presenting a rigid surface, which would act too roughly upon them. The operation of rippling is performed by hand, drawing successive bundles of flax through the upright prongs of the ripple. The bulbs being greater in diameter than the distance apart of the rods, they are therefore stripped off and fall upon a sheet spread upon the ground under the plank for this purpose. Flax should not be rippled severely, since it is better to leave some of the seeds on than to run the risk of bruising or splitting the delicate fibres about the top of the plant. As each handful is rippled, it is deposited on the ground on the left-hand side of the operator, one being placed diagonally over the other until a sheaf is completed, when it is bound up and removed for—

**Retting.**—The next process and one of the most important is *retting*, *steeping* or *watering*, which requires from 10 to 14 days. The object of retting is to dissolve by means of decomposition the gummy or resinous matter which exists between and binds together the outer membrane and inner stalk, by submersion in water for the previously mentioned time. Pure soft water is claimed to be the best for this purpose. Hard water, or water containing lime must be avoided, and water containing iron will give the flax a rusty, or what spinners call a foxy color. The size of steeping pools or retting dams may vary from 8 to 20 feet in breadth, 30 to 50 feet in length and from  $3\frac{1}{2}$  to 4 feet in depth, according to the requirements of the district. These pools must be thoroughly watertight, and after the flax is put in, no water admitted or run off until the flax is taken out. The color of the flax is also affected by the nature of the soil in which the dam is located. In Ireland, which is the country most famous for its flax industry, a rich blue, or what is called clay color, is liked best. The *beets* or sheaves are placed loosely and in regular rows with the root ends downwards. They are next covered with rag-weeds and sods, and weighted with stones to keep the flax firmly under water. If the weather is warm fermentation commences in two or three days, and generally in 13 to 14 days this fermentation has proceeded far enough to permit the removal of the flax from the pool. To ascertain if the flax is ready for removal, take out four or five reeds; if you find them covered with a greenish substance, and if the woody shore separates freely from the fibre on breaking the stem about six or seven inches apart, the operation is complete. The coverings must then be taken off, and the flax removed from the pool carefully by hand, and allowed to drain and dry for a few hours preparatory to being spread evenly and thinly on a meadow.

**Grassing.**—The object of spreading the stalks, called *Grassing*, is, that by the action of the air and sun the drying process is completed as well as the fibres bleached. This process of grassing also renders the wood part, *Shove*, short and brittle, and easily crushed and broken. The most suitable place for spreading is grazing land of short and thick grass. In spreading the flax the same must be laid down thinly and evenly over the field and in a few days turned so as to finish the process more rapidly and perfectly. About 5 to 6 days is the average length of time required for grassing, but this, of course, depends greatly on the atmosphere. Under no circumstances should flax be spread in wet or

damp weather. As heretofore mentioned, by means of the grassing operation the woody part of the flax gets brittle and breaks, easily separating from the fibre. The general method for testing if flax has been spread long enough is, to crush and rub a few stalks between the fingers and ascertain if the wood breaks easily or not. If found so, the flax is ready for *lifting*, tying in bunches and storing for the *scutch-mill*. Another method in use for retting flax is what is called *Dew-retting*.

In *Dew-Retting*, the flax is grassed (spread on meadow land) without steeping, simply exposing it to the action of the weather for six or eight weeks. Damp weather is the most suitable for this system of retting, since all fermentation ceases if the flax becomes dry. Some of the best flax produced, either by dew or pool retting, is such as raised in the country of Waes and Brabant, Belgium, and which is known as *blue flax*, from its very dark color.

A third method of retting is what is termed—

**Cold-Water Retting.**—The best flax gotten in this manner is the *creamy Flemish flax*, as found in the neighborhood of Curtrai, in Belgium. It is steeped in the soft, slowly-running, almost sluggish waters of the river, *The Golden Lys*, which, although not stagnant, has the property of causing fermentation, and gives it a fine cream color. The finest grades of this flax, after being steeped and dried, are stacked until the following year, and then steeped a second time. (In addition to the well-adapted quality of the water of the Lys for retting purposes, there are other important factors which aid in the result of producing this excellent fibre. They are: a soil preparation, with systematic rotation of crops and extent of fertilizing that few, if any, of our flax farmers have ever practiced; the use of only the best of seed, and, lastly, the most careful handling and skilful manipulation from the time the crop is ready to pull until the straw goes to the scutch-mill.)

The highest price for this flax is about \$800 per ton, but it is known that \$1,300 per ton has been paid, when bought for special purposes. The value of the low Russian flax (compared to the former) is only about \$120 to \$130 per ton.

A new method of retting flax, which has for its object the hastening of the process by a series of connected steps or treatments, has lately been patented in this country, and is as follows: After the flax has been pulled and the bolls removed (*i. e.*, rippled) the same is placed in a tight receiver or vessel, where it may be agitated, if desired, but where it will be subjected to the action of hot water under a pressure of from 20 to 60 pounds to the inch, and so remain for a period of about an hour, for the purpose of making soluble the gummy and starchy elements of the material and for expanding the stalk and woody parts of the material. After being thus treated, as stated, the water and pressure are removed and the material in the receiver is treated with cold air for about an hour, or time enough to cool it, this cooling having the effect of separating the fibrous cuticle from the woody stalk part. After being thus cooled, the material is treated in the receiver with a steam pressure of from 30 to 60 pounds to the inch for about an hour, to expand the cellulose of the bark or cuticle, which by the preceding steps has been caused to cleave from the woody stalk parts of the material. After being thus treated under steam pressure for the time before stated, the material is then treated with cold water to remove the gummy, starchy and earthy elements made soluble by the process before named. After being thus treated the fibrous cuticle is free from the woody stalk centre of the flax, and also free from gummy and starchy elements, and in good condition for scutching, roughing, hackling, etc. The second treatment used in sequence to the former serves to still further divide up the cellulose and removes the soluble material adhering to the fibre after the condensation following the first treatment. This method of quick retting of flax is claimed to be also available for jute, hemp, and other forms of vegetable cellulose, using less time for treatment and less pressure than that before-named, where the size of the stalks is small, but increasing the time and pressure from that before-named, where the size of the stalks is larger.

**Scutching.**—The next process to which the flax-plant is subjected is *scutching*, which can be done by power or hand work.

In *hand-scutching* the flax is broken by threshing it with a wooden mallet. Fig. 318 illustrates a *hand-brake* as used in connection with this operation, and consists of three slats of hard wood fastened at one end to a solid stand and having the other end mortised into a frame. Fig. 319 illustrates a *gavel-holder* which is a great convenience in holding of flax during the process of breaking. The

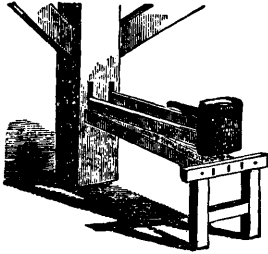


FIG. 318.



FIG. 319.

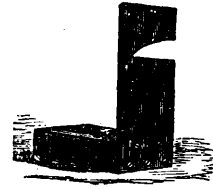


FIG. 320.

FIG.  
321.

scutcher must always commence threshing at the root end. After breaking the stems of the flax, a convenient amount is hung through a niche in an (upright) *scutching-board*, see Fig. 320, and struck several times with the blade of a *scutching-knife* (of which three different specimens are shown; see Figs. 321, 322 and 323) until the fibre is completely cleaned, *i. e.*, the operator by means of the scutch-

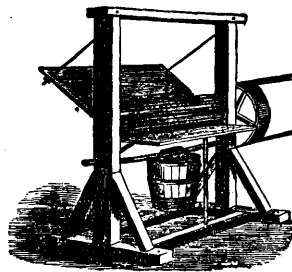
FIG.  
322.FIG.  
323.

FIG. 324.

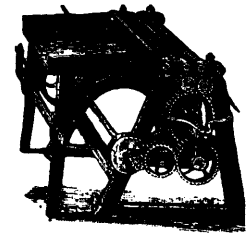


FIG. 325.

ing, breaks up the outside membrane into fibres, and removes the internal woody part, which of course falls to the ground.

In scutching the flax by machinery, *power-scutching*, the same is submitted to a *power-brake*, of which we give illustrations of three different makes in Figs. 324, 325 and 326. In Fig. 324 which is

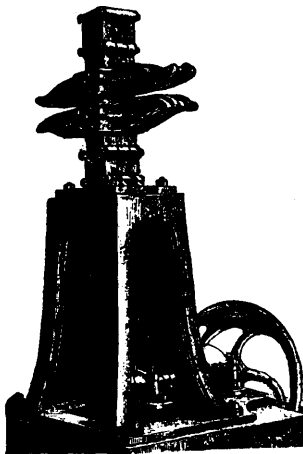


FIG. 326.

the most simple in its construction, the flax has to go through two fluted iron rollers for the purpose of breaking the woody part into small bits, leaving the stalks pliable and so manageable for the *power-scutcher*. In Fig. 325 a better built and more effective style of a flax-brake is shown, consisting of two pairs of fluted iron rollers between which the flax as spread on the feeding-table must pass. Fig. 326 illustrates another flax-brake. In this machine two sections of several iron rods arranged in the shape of a grate are moved against and with their edges slightly past each other and back again, thus breaking the flax held between during the operation. After the flax has been broken on either one of these flax-brakes, the same is submitted to the power-scutcher, of which we give illustrations of two styles of machines as used, in Figs. 327 and 328. Fig. 327 illustrates the

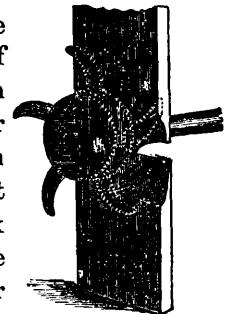


FIG. 327.

most simple specimen as to construction, consisting of a wooden shaft, having five scutching-knives set in it similar to the spokes of a wheel. These scutching-knives must be set perfectly true so that each strikes exactly the same spot as the previous one. They

are thick at the back and tapering on one side to a pretty sharp edge, the plain side being placed next the stock. The scutching-knives revolve close to a wooden or metal upright stock or scutching-board at the back of which the man stands, putting the flax over the top and allowing the blades to strike it and so clear off the wood. Fig. 328 illustrates a more practically constructed machine,

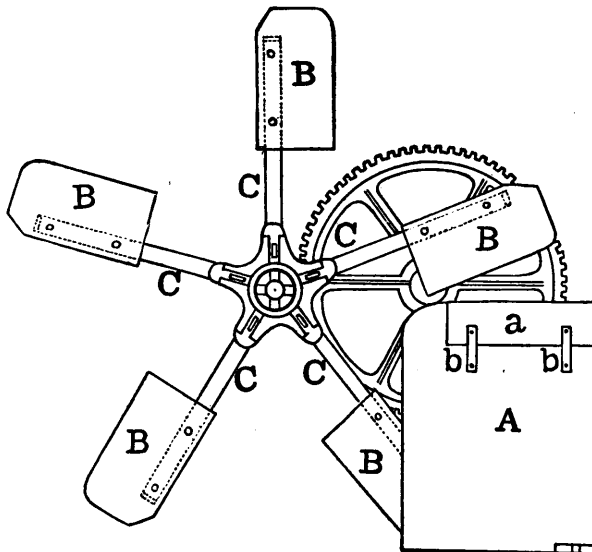


FIG. 328.

yet in its principle it is similar to the previously explained scutcher. Five scutching-knives are used, see *B*, each one fastened to one of the arms *C*. In using this machine the flax is generally submitted to two operations, the *rough-scutching* and the *finishing-scutching*. For rough-scutching the knives are set some short distance apart from the scutching-board (see *A*,) whereas, for the finishing operation, the knives are set to work closely toward the scutching-board. The upper part of the scutching-board has a rectangular-shaped piece (see *a*,) cut out, and the same fastened or held in its original position by the two steel braces *b*. This is done to permit a slight outside motion of the piece *a*, hence to save the fibres in case the knives are set too close, or a few extra heavy stems mixed in with the material. The average speed of a power-scutcher is 200

revolutions per minute, hence  $200 \times 5$  (five knives used in the machine) = 1,000 strokes of knives upon the flax per minute.

**Improved Power Scutcher.**—An ingenious machine for scutching flax has lately been invented by McGrath and Manisty. The invention relates to an apparatus for scutching or similarly treating flax (and other fibrous materials as jute, hemp, &c.) in a continuous manner and embraces means of

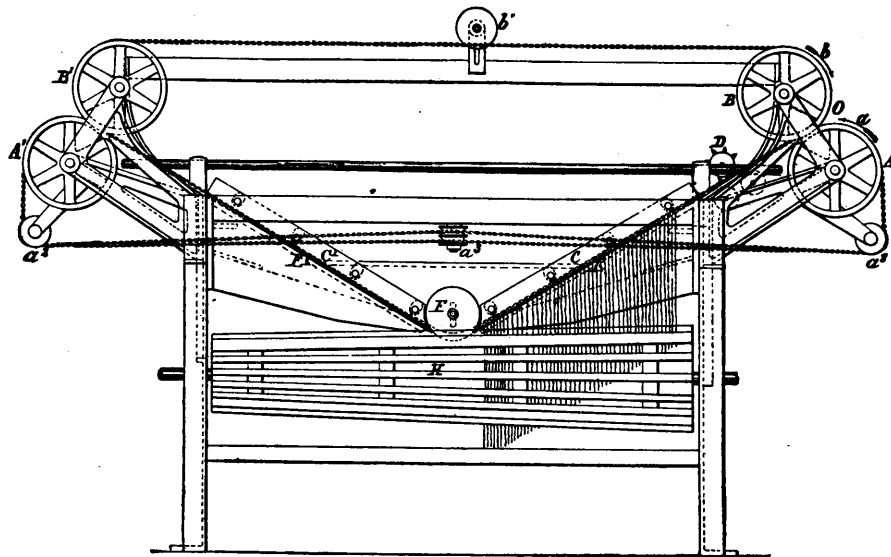


FIG. 329.

automatically taking hold of the material by traveling chains or cords as it is fed continuously, and thus firmly grasping about half the length of the stems, while the other half hangs freely downward, causing the material thus grasped to travel along an inclined guide, while the free parts are acted on throughout their length by revolving scutches, and finally releasing the parts that were grasped so that

they in their turn can be scutched, while the parts already scutched are similarly grasped and moved.

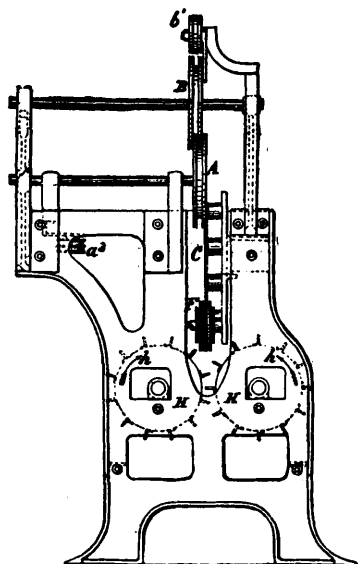


FIG. 330.

Diagrams, Figs. 329 to 337 are given to convey a clear idea of the apparatus and procedure. Fig. 329 is a side view; Fig. 330 is an end view, and Fig. 331 is a plan of the machine. The other figures drawn to an enlarged scale are: Fig. 332, a part side view, and Fig. 333 a part plan, showing the arrangement of the chains at the entering end of the inclined guide. Figs. 334, 335, 336 and 337 are part transverse sections on the lines  $z$ ,  $z^1$ ,  $z^2$  and  $z^3$  respectively of Fig. 333. Letters of reference in all nine illustrations are taken correspondingly. In bearings in a suitable framing are journaled the shafts of two scutching-drums  $H$ , which are driven at considerable speed in opposite directions, as indicated by the arrows  $h$ . These drums may be cylindrical or of equal diameter throughout, but it will be advantageous to make them taper as shown in our illustrations, so that at the entering or right hand end where the scutches act first on the fibrous material, breaking the woody substance of the stems, they have greater speed than they have at the leaving end, where they act chiefly for brushing or clearing off the woody fragments. In the upper part of the framing are mounted two pairs of chain-wheels, one pair  $A$ , below and a little to the one side of the other pair  $B$ . These are driven in

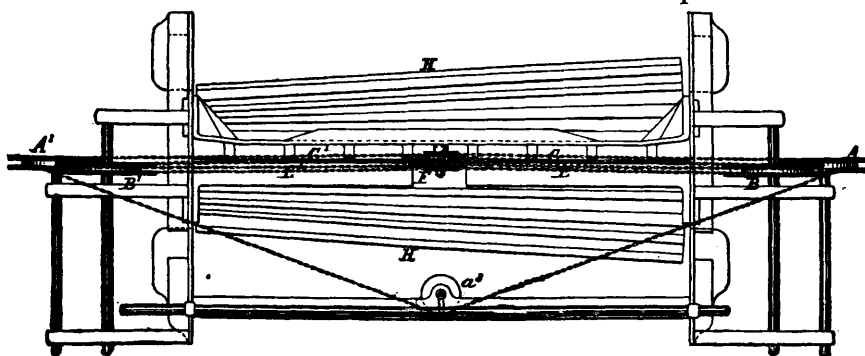


FIG. 331.

opposite directions, as indicated by the arrows  $a$ ,  $b$ , at a relatively slow speed, for example, the scutch-drums  $H$ , should revolve from thirty to forty times faster than the chain-wheels  $A$ ,  $B$ , for the average quality of flax; but this proportion may be varied according to the quality and the nature of the material operated upon. By the chain-wheels  $A$ ,  $B$ , four endless chains 1, 2, 3 and 4 are caused to travel down an inclined carrier rail  $E$ , under a guide-pulley  $F$ , up an inclined rail  $E^1$ , around chain-wheels  $A^1$ ,  $B^1$ . At the left hand end of the machine the chains from the wheels  $A$ ,  $A^1$  are led by guide pulleys  $a^1$ ,  $a^2$  and a tension pulley  $a^3$ , obliquely away and back in a horizontal plane, and the other two chains from  $B$ ,  $B^1$ , are led under a tension pulley  $b^1$ , at the top of the machine. A star-wheel  $D$ , is so arranged (as shown more clearly in Figs. 332 and 333) that its teeth or

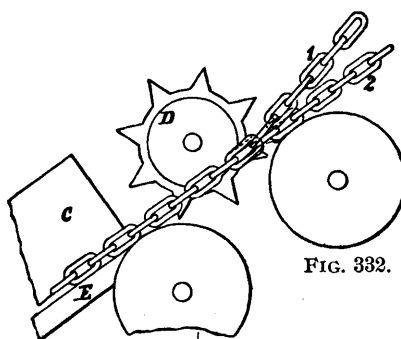


FIG. 332.

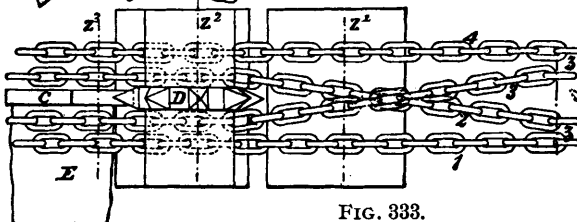


FIG. 333.

scutched, while the parts already scutched are similarly grasped and moved.

rays penetrate between two of the chains, 2 and 3, just beyond a point where these chains cross each other, one above the other (as shown in Fig. 333), and before the four chains reach the beginning of the inclined rail *E*. This star-wheel is free to revolve, being driven by the friction of the chains that bear against its sides. A little above the front edge of the carrier-rail *E*, and parallel to it (as shown in Fig. 337) is fixed a skid-rail *C*, leaving between its lower edge and the upper face of the rail *E*, a narrow space not wide enough to allow any of the chains to pass through it. The material is fed in between the chains passing around pulley *B*, and those passing around pulley *A*, and will assume the position shown in Fig. 334 by reason of the chains from said pulleys being carried past each other by the alternating overlapping peripheries of said pulleys on which the chains are carried. After passing between the pulleys, the chains 2 and 3 are crossed and carried upon opposite sides of the star-wheel *D*; and in effecting this the flax is brought into the position shown in Fig. 335, in which it will be noticed the relative positions of the chains 1 and 4, are the same as in Fig. 334, while the chains 2 and 3 have simply assumed the opposite relative positions ensuing from their crossing, caused by the intervention of the star-wheel. By now bringing all four chains into substantially the same horizontal plane, which is the position they naturally tend to assume after passing the star-wheel *D*, owing to the guidance of pulley *F*, the overlapped loops of fibre are formed, as shown in Fig. 336, forming the triple strand between chains 1 and 3 and chains 2 and 4. The triple strand thus formed is



FIG. 334.



FIG. 335.

then drawn under the edge of the skid-rail *C*, as shown in Fig. 337. While nearly half the length of the fibrous material is thus grasped, there hangs from between the chains 2 and 4 somewhat more than half the length of fibrous material free, which, as the chains move along the incline *E*, downward, is caught between the scutch-drums *H*, and acted on by their scutches or beaters, first at the lower end, and then at parts gradually higher and higher, until the lowest part of the incline is reached. The whole length of free fibres being thus scutched, it is again acted on as the chains ascend the slope *E*. At the left hand end of the machine the chains are made to alter their relative positions in an inverted order by simply crossing chains 2 and 3 after they leave the skid-rail *C*, and carrying them to the pulleys *A*<sup>1</sup>, *B*<sup>1</sup>, respectively, so as to release the fibres from their entanglement; and the fibres, having one part, about one-half of their length, scutched, are delivered from between the chain-wheels *A*<sup>1</sup>, *B*<sup>1</sup>. By feeding the fibrous stems in an inverted position into the machine again at its right hand end, or into another similar machine, so that the scutched part of their length is grasped by the chains, while the part hitherto unscutched hangs free, the scutching of the whole length can be accomplished. The scutches or beaters on the drums *H*, may have plain edges, or edges waved, serrated, or indented, according to the character of the material on which they have to operate. Throughout half the length of the drums the beaters may be of one pattern for breaking, and throughout the other half they may be of a different pattern, suited for brushing off the woody fragments from the fibres. The guide pulley *F*, has the outside grooves of less diameter than the two intermediate grooves, to permit the same to be set down deeper between the drums *H*, than if all the grooves were of the same diameter. The scutching-drums *H*, and the chain-wheels *A*, *B*, may be arranged either to be driven independently from any convenient motor, or they may be connected by any suitable gear to give them relative speeds required.



FIG. 336.

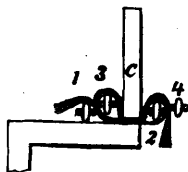


FIG. 337.

A competent scutcher aims to thoroughly separate the fibre from the woody part with as little waste as possible. No doubt there will always be more or less short fibre removed along with the unworkable matter, the percentage of loss being greater when the retting process has been slighted. These short fibres called *tow*, when removed from the woody droppings, are afterwards manufactured (by means of carding in place of hackling and spreading as used for linen yarns) into an inferior grade of yarns known as *tow-yarns*. When scutched, a good flax fibre is of a bright silver-gray color, and glossy (resembling silk) in its appearance. When dark in color or of a greenish tint, the fibres are either of an inferior quality, or have been imper-

fectly treated during the previously explained manipulations. After scutching, the flax is ready for the market, *i. e.*, the spinning mill.

**Flax Spinning.**—Under this name we technically classify all the different processes the fibre is subjected to for producing either flax or tow yarns; *i. e.*, roughing, hackling, spreading, carding, drawing, roving and spinning.

**Roughing** is the first process the flax is subjected to in a spinning mill, and the object of the operation is, to divide the flax into *pieces* of a certain size, this being regulated according to the description of the flax. The work is done by the *rougner* by means or help of a hackle. He places the root end of the flax in the hackle and holding the piece by the crop end, then pulls it out. Consequently fibres that were loose or straggling are left in the hackle, which are then taken out and placed evenly on the piece with the others. Some roughers place both ends of the flax (successively crop and root end) in the hackle for pulling out the loose or straggling fibres. The pieces of flax after thus being separated according to length are next drawn across the hackle, thus being opened up and freed from any lumps, knots and coarse tow. The loose fibres left in the hackle are afterwards broken off by means of a *touch-pin*. When each handful of the material has thus been fully operated upon, the rougher gives it a slight twist so as to keep each piece separate. When roughing is found too expensive a process, *stacking* is substituted, which consists in piecing the flax in double pieces, straightening out their length some, next opening on the hackle and breaking the root ends. Stacking is done by boys, whereas

roughing is men's work. In some instances both processes are done away with, which is a great error, for spinners will lose a great deal more in waste during spinning operations.

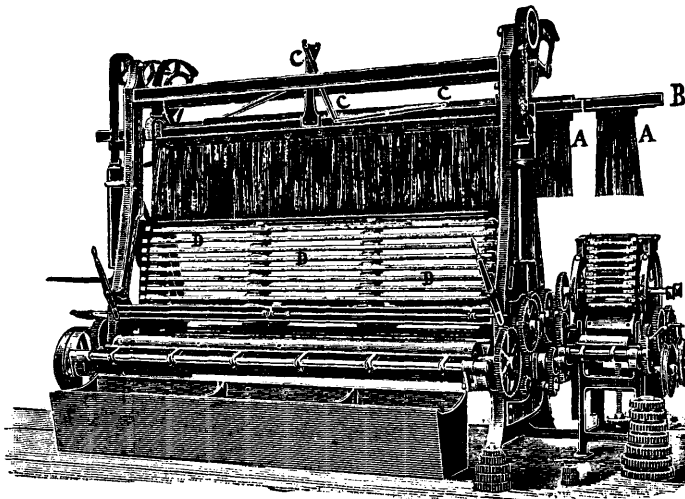


FIG. 338.

**Hackling** is the next process through which the flax passes in a spinning mill and consists in the splitting of the fibres to the finest condition they are capable of assuming without detriment. The work is done on the *hackling machine*, of which we give an illustration in Fig. 338. The flax arranged in bundles by the rougher at the finishing of the roughing process, is now taken in charge by a boy or girl called a *filler*, who lifts two pieces of flax off the rougher's bench before him, ar-

ranges the same between two small iron plates called *holder*, and which are then screwed securely together by a bolt and nut through their centres. To secure a positive grip of the holder, the inside faces are covered with corrugated india rubber or cloth. After the filler has filled the holder, he places the same (see *A*) on their edges in a horizontal groove or channel (see *B*) running along the machine above the hackle needles, which revolve on two parallel rollers working into each other. From the channel overhead the flax is hanging between the cylinder needles, which when revolving pierce it, splitting or reducing the fibres to the finest condition they are capable of assuming, as well as combing off all impurities from the fibres, leaving them straight and parallel. Inside the head (or channel) of the machine is a rack working upon a slide. This rack, by means of detents, catches the holder as soon as it passes into the channel and moves it along the channel towards the other end of the machine. By means of cams and connecting rods (see *C*), the channel alternately rises and lowers towards the hackle, thus permitting the flax from the edge of the holder downwards to be fully operated upon. Each time the head rises to its full height each holder in the machine is moved its



own length forward, the flax always passing, as before, between the two vertical sets of hackles, but in a finer set. These two sets of hackles (see *D*) are technically called *tools* and the number of tools to each sheet varies according to circumstances, the coarsest coming into contact with the material first, and the finest when the end of the traverse has been reached. These tools penetrating the flax would easily get clogged but for their being automatically cleaned by means of rotating brushes fixed upon wooden cylinders. These tools are not arranged in single rows, but in pairs, one higher compared to the other. When the holders containing the flax have passed over the width of the machine, they are then automatically deposited upon a kind of rail from whence they are removed by the boy or girl in attendance on the machine, who, laying it flat on a table and in a bed arranged to receive it, permitting

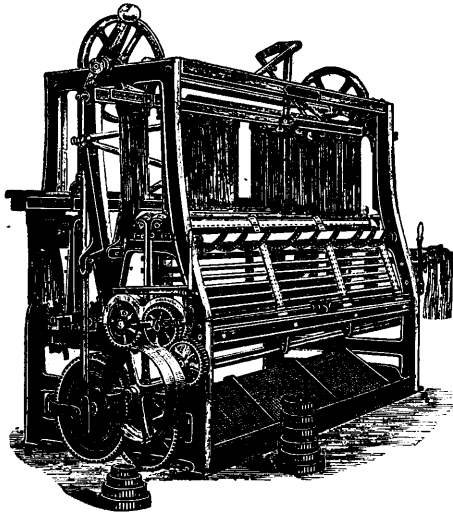


FIG. 339.

the hackled portion of the flax to fall evenly over another holder lying open in its bed to receive it. After fastening the new holder the former is opened and removed, whereas the flax in its new holder is again passed into operation by being placed in another machine and the other end combed similar to the first explained. Frequently a *double-acting hackling machine* is used. Such a machine (for illustration see Fig. 339) is really a combination of two machines in one; hence, after each holder has passed on one side, and the flax changed to a new holder, the latter is inserted and run through number two division (or the other side). When this operation is completed the flax is taken from the holders and placed in a box, the pieces being laid crosswise upon each to keep them separate for future processes. Underneath the hackles, boxes or baskets are placed to receive the combings, called *tow*, which are used for the manufacture of inferior yarns known as *tow-yarns*. Each parcel of hackled flax is called a *tipple*, and after the box is filled with them, it is

removed to another department to undergo the operation of

**Sorting.**—In the sorting room each box of hackled flax is separated into various qualities. At the same time the fibre is pulled by the sorter through a coarse hackle called a *ten*, broken, and afterwards cleaned out over a finer hackle called a *switch*. This work in addition to sorting requires men who are good hacklers as well as experienced sorters. To supply roughed flax for a hackling-machine requires the work of four roughers, whereas seven sorters (on an average) are required to dress and sort the hackled flax obtained from one machine.

**Spreading.**—This is the next process to which the dressed and sorted flax is subjected, and is produced on the *spread-board*, of which an illustration is given (feeding end) in Fig. 340. The object of spreading is to produce

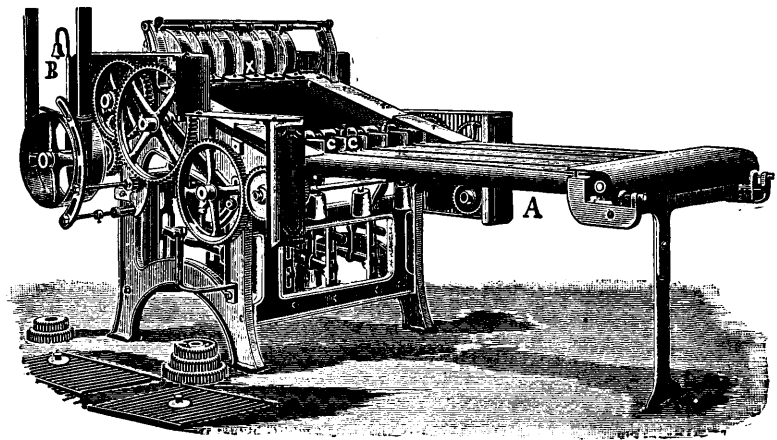


FIG. 340.

a sliver out of the bunches of dressed and sorted flax, as is done in worsted spinning by means of the preparer. The spread-board is about ten feet long and four feet high and wide. Examining our illustration we find the feeding table indicated by *A*. Upon this table the

flax fibres are spread in even layers, having the length parallel to the direction of the motion of the line, and so arranged that the pointed ends of the one flax bunch overlays into the next, thus producing a continuous bunch of about the same thickness. It must be remembered that the root end of the bunch will be always heavier than the crop end, hence care must be taken to spread all the bunches in the same direction, *i. e.*, have the root end of the one bunch overlap with the crop end of the succeeding bunch. At the end of the table and connecting with the machine we find the vertical partitions indicated by *C* in diagram. Between those the spread flax passes in its course to a pair of rollers (feed-rollers) which after once taking hold of a bunch will pull the others gradually along. On the upper part of the machine we readily notice in the illustration a second system of rollers which are indicated by *X*. These rollers in turn take the bunches of flax from the first set of rollers, and having a greater surface-speed compared with the first set of rollers, consequently pull or draw on the bunches of flax after they leave the first set of rollers. If we were only to submit the flax to the action of these two pairs of rollers, no doubt the bunches of flax as overlapped on the table before feeding in the machine, would again easily separate after leaving the second pair of rollers. To prevent this a peculiar and ingenious arrangement of combs called *fallers* is added to the machine. This system of combs catches in the fibre from underneath, between the feeding and drawing-rollers (first and second pair of rollers previously mentioned) consequently hold the fibres, draw, and at the same time prevent a separation of the material. The fallers as previously mentioned are situated

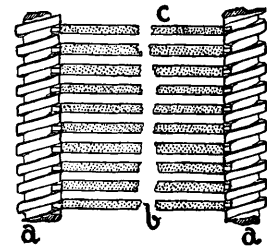


FIG. 341.

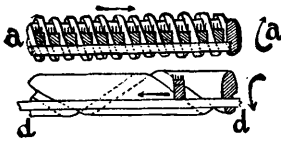


FIG. 342.

below both pairs of rollers, and thus are not visible in the illustration of the machine. In order to illustrate the subject in detail to the student, the following four special illustrations, Figs. 341, 342, 343 and 344, are given (letters of reference in all four diagrams are selected correspondingly). Fig. 341 shows their top view. The pins or gills are fastened upon little narrow strips of steel of a rectangular section, (fallers) each of which rests on both ends in the thread of an endless screw *a*. Turning the screws consequently moves those individual fallers along parallel with each other. After each faller in succession has traveled the distance from *b* to *c*, as shown in the illustration, it is lowered by means of an ingenious arrangement (shown in Fig. 342) below the working combs and returned in the threads of the screws at *b*. Examining illustration Fig. 342 we find below the screw *a*, another endless screw indicated *d*. As soon as each gill has finished the thread of the screws *a*, they fall down and are taken up by the lower screws *d*, which in turn guide each faller back. Arriving at the end of screws *d*, the same is taken hold of and lifted by means of an arrangement of levers (as clearly visible at *e*, in Fig. 343) in the threads of the screws *a*, to commence work over again. Fig. 344 shows an individual faller as well as the sections of the screws *a*, also clearly indicates the manner in which the ends of the fallers rest on the threads of the screws. The thread of the lower situated screws is such as to produce a quicker movement of the fallers compared to the motion of the fallers produced by the upper or working screws. This permits the use of a less number of fallers than if both sets of screws were to have the same thread.

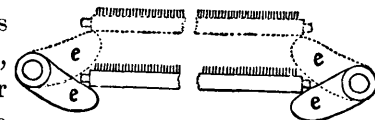


FIG. 343.

As previously mentioned, the bunches of flax spread on the feeding table of the spread-board are stretched or drawn out by means of the two pairs of rollers called feed-rollers and delivery-rollers, and are mixed in a solid continuous sliver by means of the gills of the fallers. Out of each one of the six bunches of hackled flax fed into the spread-board we find only a single (and proportionately thin) sliver leaving. This sliver is caught by two conductor rollers situated in front of the machine, which deliver it into cylindrical cans (sliver cans) placed in front to receive it. Each yard of sliver so delivered is measured previously to its delivery in the sliver can, and registered by a simple arrangement. *B*, in illustration Fig. 340, shows the bell which rings when

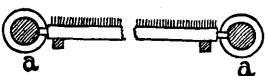


FIG. 344

a certain fixed length of the sliver has been delivered into the can, and which, after being filled, must be replaced by an empty one, to be filled in its turn. The intervals at which the bell rings can be altered, by change of wheel, to suit any required length of sliver (from 300 to 2,000 yards) to be delivered in the can. The measuring of the sliver as it leaves the spread-board is necessary, since it is essential for future operations to be able to produce the sliver of a given weight for a certain number of yards in length.

A certain number of the measured cans are weighed, the net total being given as the weight of the *set*. Since all cans in a set must be doubled into one sliver, there are actually only so many yards to this weight of set as there are yards in the bell, hence it is only a question of calculation to ascertain the yards per pound or ounce. The length of the sliver will be increased during future operations; *i. e.*, drafting and doubling. Rule.—The shorter the drafts and the greater the doublings, the lighter will be the set required to produce a given number of yards; and the longer the drafts and the less the doubling, the heavier must it be to produce the same number of yards. For fine and special preparation light sets must be produced.

The spread-board is capable of spreading, drawing, stretching or extending the bunches of flax to from 25 to 40 times their original length, as when fed in the machine. As previously mentioned, every division of flax bunches is fed to its own set of feed-rollers, as well as corresponding drawing-rollers; hence in most machines six sets of these rollers (corresponding to the divisions on the spreading table) are used, though some machines are built to contain only four departments each in place of six. The feed-rollers are made of iron and extend across the machine, whereas there is a special drawing-roller for each sliver. The latter are made of hard wood and are firmly pressed to the bottom roller (by means of hand-screws) from the contact of which they derive their motion. This prevents any possibility of the material slipping while passing between the same, and keeps the *draft* perfectly uniform at every point. Before continuing the explanation of the further processes, the sliver on leaving the spread-board is subjected to, we must mention another process by means of which a sliver is also produced, *i. e.*

**Carding.**—This process is required for producing the characteristic sliver from the short fibres and impurities that come from flax during scutching, hackling and dressing. These fibres are technically known as *tow*, and are put through a different process than is done with the line flax so far. To produce a sliver from tow the carding engine is brought into requisition. The process of carding tow consists in arranging the mixed up fibres parallel to each other, to form a continuous lap, and then convert the same into the sliver ready for the succeeding operations. Thus in its principle the carding of the tow is the same as the carding of the cotton, the only difference being found in the construction of the different parts of the carding engine. Tow as compared to cotton is of a coarser nature, also a correspondingly longer fibre, consequently the working parts of the carding engine as used for tow, must be of a heavier build, and the card clothing made of pins set rather open. There are two kinds of cards in use;—*breaker card* and *finisher card*. The tow is first put through the breaker card or coarse card and there sometimes mixed with coarse grades of hackled flax (which are termed *milled tows*) and afterwards carded on the finisher card and successively prepared for spinning into tow yarns.

**Breaker Card.**—This consists of a large cast-iron cylinder, of about three to five feet diameter, and four to eight feet face or width. This cylinder, called a *swift*, rests upon strong cast-iron stands, and in operating, the machine is made to revolve at a great speed. The stands are also arranged to carry the axles of several rollers of similar face covering as the swift, but of a much smaller diameter. These rollers revolve in different directions, but parallel and facing close up to the large cylinder or swift. The clothing for swift and the rollers are pins of a size and texture (number per square inch) to suit the grade of the raw material to be worked upon the carding engine. To illustrate the process of carding Fig. 345, representing such a carding engine, is given. The tow is placed upon the feed-lattice or apron *A*, which is divided into three subdivisions (see 1, 2 and 3). This feed-apron passes the tow spread upon it between two rollers parallel to one another and to the face of the swift. These rollers, called feed-rollers, are about three inches in diameter, revolve in opposite directions and inwards

towards the swift. They are, as the name indicates, the medium of feeding the tow to the swift or main cylinder, which revolving downwards, strikes and carries away the tow from the feed-rollers. The average clothing of the swift consists of pins about  $\frac{7}{8}$  inch in length, set at a slightly downward inclination through strips of wood from  $\frac{3}{8}$  inch to  $\frac{5}{8}$  inch thick, 3 inches broad, and 24 inches long, and which are screwed to the cylinder. This will give us an actual length of the pins over its wooden clothing of from  $\frac{1}{4}$  to  $\frac{1}{2}$  inch ( $\frac{7}{8} - \frac{5}{8} = \frac{2}{8}$  and  $\frac{7}{8} - \frac{3}{8} = \frac{4}{8}$ ). As previously mentioned, the points of these pins face close up to the pins in the feed-rollers, and as the latter deliver the tow, the pins of the cylinder strip it slowly away. The roller on which most of the material rests is the one uppermost, and which, by being merely a hooker-in, allows the fibres to hook against the pins of the cylinder. Hence the latter does not take too much away at once; besides such of the fibres as it does take are pretty well broken by means of the splitting between the points of the pins. To prevent tow from clogging the lower feed-roller there is a *feed-stripper* connected to its under side, and at the same time to the cylinder. This feed-stripper revolves at a high rate of speed in the direction of the cylinder, and has its pin hooked in toward those of the cylinder and of the lower feed-roller. The feed-stripper consequently strips the tow out of the lower feed-roller, and in turn gets stripped itself by the cylinder. The cylinder or swift carries the tow from the feeding-roller (towards the lower half of the carding engine) until caught up by the first *worker*, which has the same diameter as the feed-stripper, and

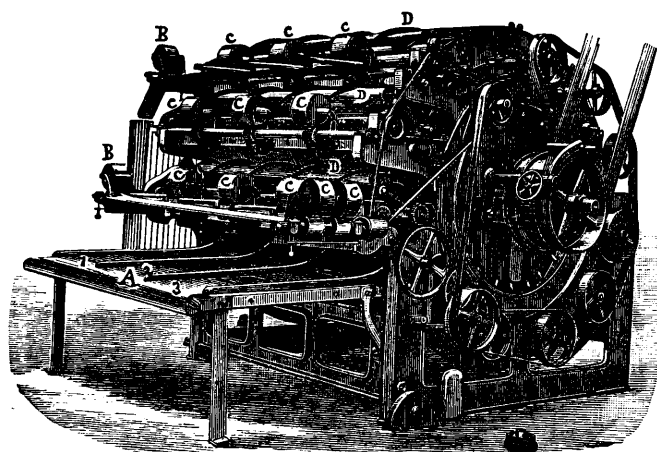


FIG. 345.

which revolves slowly in an opposite direction from the swift, having its pins hooked against the pins of the swift, so that they lift away those fibres that are on the swift, at the same time splitting them still more between the points of the pins. This first worker is stripped by the roller as situated between it and the feed-stripper, called the first *stripper*, and which revolves at a high rate of speed in the same direction as the worker, stripping the fibre of the worker and returning it to the swift. The setting of the pins in the stripper and the swift is such as to work in towards one another; consequently there is only a delivery of the fibres from

the former to the latter; all the cutting of the fibres being done between the pins of the swift and those of the workers, the pins of the latter being hooked against those of the former, and revolve slowly in an opposite direction. The continuous retaining, stripping and delivering of the fibres to and fro from the swift in return, cleans, equalizes and splits the fibres; the process is carried on around the swift over as many pairs of workers and strippers as there are in the card. The number of these workers and strippers employed is regulated by the fineness of the card. When the *baird* arrives at the last worker on the card it is consequently stripped by its mate stripper, and from there carried to the swift until intercepted by the next roller, which is of a large size, called *doffer*, and works on the same principle as a worker, only without a stripper-roller to clean it. From this doffer the tow is taken off by a quickly oscillating comb, called *doffer-comb*, which beats down the tow from the pins. The tow is then separated into three divisions, and drawn through calender-rollers *C*, in the form of a coarse sliver. In the same manner the fibres are stripped off one or two other doffer cylinders situated beneath this first doffer. The three slivers as coming from the calender-rollers are either run off individually into cans arranged near the machine to receive them, by means of conductor-rollers *B*, or, as is mostly the case, they are united in one sliver before leaving the card. After filling the cans with slivers, they are taken to a machine and lapped onto large bobbins or reels, and when the latter is filled, taken and set in a creel or rack before the feed-rollers of the finisher card, taking the place of the feeding table in the

breaker card. Below each doffer we find a revolving brush *D*, whose object it is to clean the clothing of the respective doffer from any possible impurities adhering to the fibres.

**Finisher Card.**—This machine is constructed on the same principle as the previously explained breaker card, the only difference being that the clothing is finer and thicker set, shorter pins in the clothing being used, and also more pairs of rollers of a smaller diameter so as to give more working to the fibres.

**Combination Cards.**—These machines are intended for carding the better grade of tow, for which one operation is sufficient. This carding engine is also called *breaker and finisher* from the fact of its being a combination of both as well as being a machine which does with one manipulation for the better grade of tow, which for a coarse grade requires the two separate manipulations as previously explained. In this combination card of which we give an illustration in Fig. 346 the tow is, similarly as done in the breaker card, spread evenly upon the feeding table *A*, and delivered in an even body to the machine to be separated into as many slivers as there are front conductors *C*. These slivers are next passed on the sliver plate *E*, which is a polished cast iron plate as long as the face of the carding engine and sufficiently deep to permit the various slivers, into which the deliveries have been doubled, to be carried round large pins (horns) then along the sliver plate into the back conductors of a small card-drawing head which is called a *rotary*, and from which the separately entering slivers emerge in one sliver which is delivered in the sliver can ready for the next operation.

In mills where only a single carding engine is used, the material is first passed through a *teaser* for the purpose of shaking the tow loose and knocking out the impurities to allow the card to act more effectively on the fibres.

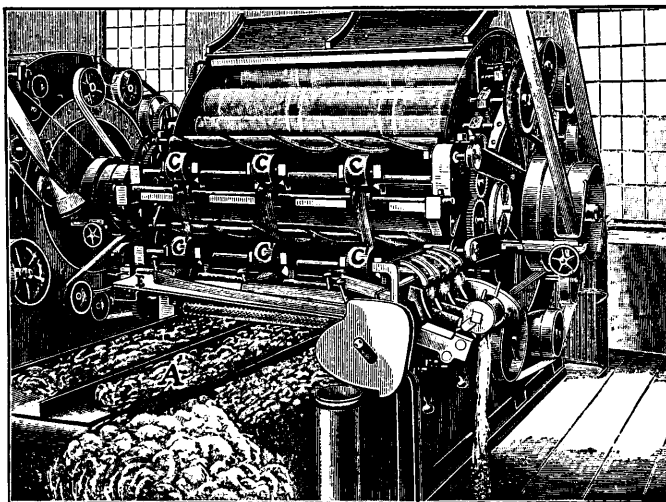


FIG. 346.

**Combing.**—The method of combing the slivers in the form in which they are delivered at the card has since the last few years been introduced in several mills. The work is done on the combing machine; the slivers as delivered at the carding engine are taken and placed up at the back, six ends generally being passed into one machine. After passing the slivers through the feed-rollers they are pierced by a series of steel pins, *combs*, which divide the fibres, lay them in parallel directions, and comb out the short fibre and various impurities. The six (or less) slivers in the machine are united and contracted into the form of a single sliver by being passed through a trumpet mouth and pair of rollers, from which they are carried to a second pair and finally delivered into a can. Connected with the delivery rollers of a combing machine by means of proper gearing, is a bell, which rings when a certain length of material has passed into the can. This is done to keep the length as delivered into each can approximately equal, hence easier for calculation in future process of drawing out the sliver to a requisite length. A better yarn, stronger and more equal, can be produced from combed material than where only carding machines are employed.

**Drawing.**—So far we have explained the production of the first sliver or foundation of the future yarn either for the *line* by means of the spread-board or for *tow* by means of the carding engine. The next machine which either sliver is subjected to for the purpose of still further increasing the fineness and uniformity of the sliver is the *drawing-frame*. Both fibres (line and tow) are from now treated by

similar processes. The tow being a shorter staple compared to the line will necessitate a few slight changes in the construction of the machinery and to which we will refer in following chapters. The drawing-frame of which we give an illustration in Fig. 347, is in its principle identical with the spread-board previously explained, as well as with the drawing-frames used in cotton spinning. The main feature of it is to pass the sliver between two sets of rollers of which the second or drawing-roller set has a greater surface speed compared to the first (or feeding-roller set), consequently a drawing out of the sliver takes place. One feature in which the drawing-frame for flax differs from the one used for cotton is the arrangement of fallers, situated between the feeding and drawing-rollers in the drawing-frame for the flax fibre. This ingenious mechanism (in its construction similar to the arrangement of the fallers in the spread-board) is of a twofold advantage; first it continues always more or less the hackling process and secondly it assists in elongating the sliver by means of having a greater speed than the feeding-rollers. The hackled flax (or line) is generally drawn three times, and with about the following dimensions as to distance of rollers. In the first drawing the distance is 28 inches, which is reduced in the second drawing to 26 inches, and in the third drawing to 24 inches. Each machine is capable of reducing the size of the sliver from 10 to 20 times, but the general plan in use is to draw out

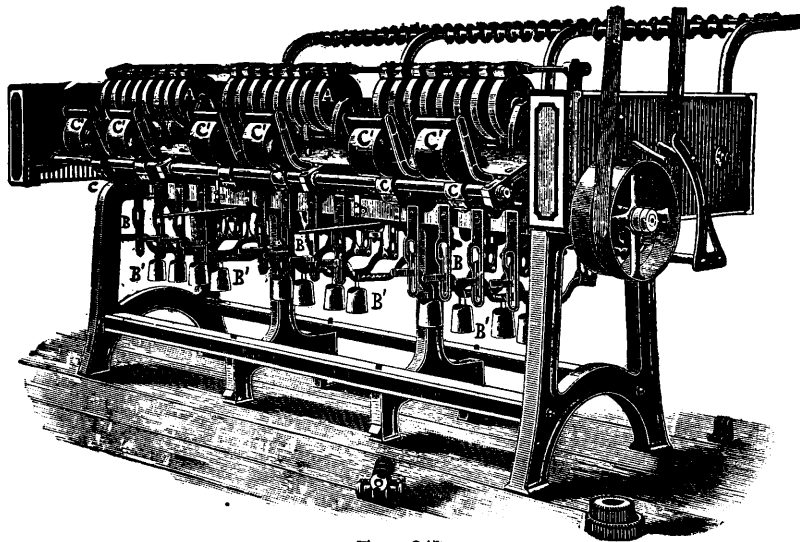


FIG. 347.

the sliver the most on the first machine, less on the second, and less yet on the third frame. During the process of drawing we also double, *i. e.*, several slivers on leaving the drawing-frame are combined together, and drawn out again to any desired consistency by regulating the speed between the rollers. The number of drawn out slivers to be doubled is regulated by the amount of drawing out the fibre, have been subjected to. In drawing tow, the sliver generally only passes through two drawing-frames, and for reason of the

shorter staple of the fibre (compared to the line) the distance between the feeding and delivery-rollers must be less than drawing line. The average distances are 14 inches on the first drawing-frame and 12 inches on the second. Both machines allow a drawing out of from 6 to 14 times, consequently the amount of doubling done in tow is less than for line. Examining the illustration of the drawing-frame we find the following letters of reference used. The pair of drawing-rollers consists of an iron roller having a larger wooden roller *A*, on top. This wooden roller is pressed by means of levers and weights (see *B* and *B*<sup>1</sup>) against the bottom roller (which is not visible in our illustration) and receives motion by means of the friction with the latter roller. The upper roller is generally made of alder wood and sufficiently large to permit its being turned off several times if getting worn or imperfect on its working surface. Frequently three separate rollers are used for the feeding arrangement. If so, the two original rollers are placed a short distance apart and each touched by the third roller. The advantage of this arrangement is readily explained. The object of the feed-rollers is to hold the sliver sufficiently tight to allow the gills of the fallers as well as the front or drawing-rollers to do their work, *i. e.* draw the sliver out by means of a greater surface velocity. Using three rolls for the feeding arrangement will actually press the sliver feed in the machine between two pairs of rollers, hence a sliding of the sliver is impossible. The sliver on leaving the drawing-rollers is taken care of by the front conductors *C* and *C*<sup>1</sup>, and guided in a sliver can ready for the next machine.

**Roving-Frame.**—This is the next and last machine over which the material passes in the preparing department, and is illustrated in Fig. 348. In appearance it is a long, rectangular frame, containing

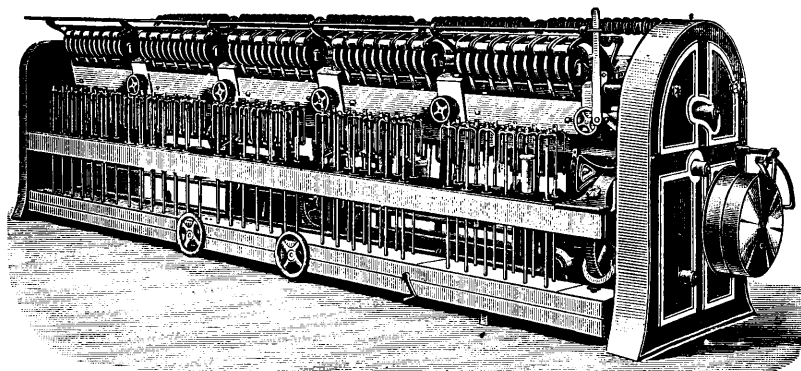


FIG. 348.

from four to eight *heads* (divisions), and each with any number of rows of gills, as 8, 10, or 12 per head, according to material to be worked. Over these gills only single slivers pass; thus there is only drafting, and no doubling, done on the roving-frame. The cans filled at the third drawing, if working line, or second drawing if working tow, are placed at the back of the roving-frame,

and the sliver passed over guide-rollers to the gills in the same manner as at the previous machines. From the gills the sliver goes to the drawing-rollers, which revolve at a speed necessary to reduce the sliver to the required size, regulated by the counts of the yarn to be spun. To illustrate the operation of slightly twisting the roving and winding it on a bobbin, Fig. 349 is given. After the sliver, by means of drafting is reduced to its required size, it, on being delivered from the front roller or drawing-roll set *a*, passes through the neck of the *flyer b*, which is an iron tube of about the shape of an inverted *U*, and which is fixed upon the top of an upright revolving spindle; from there the roving is passed through a slit in the leg of the flyer and through the flyer-eye, onto the barrel of a bobbin *c*, revolving around the spindle *d*, and under the flyer *b*. The object of this arrangement is to put some twist into the attenuated sliver (and which is now called *roving*), so as to give it sufficient strength for winding on the bobbin. This winding of the roving upon the bobbin is done by means of having spindle and bobbin revolve at different velocities in the same direction, the difference in speed being the means by which the flyer can lap the strands around the barrel. The bobbin at the same time is made to travel slowly up and down the spindle blade, so as to receive the roving in an even layer. This traversing motion is caused by the bobbins resting upon a movable tray surrounding the spindles which contain the gear-

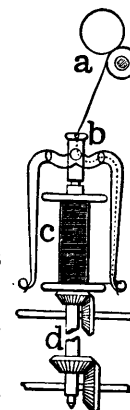


FIG. 349.

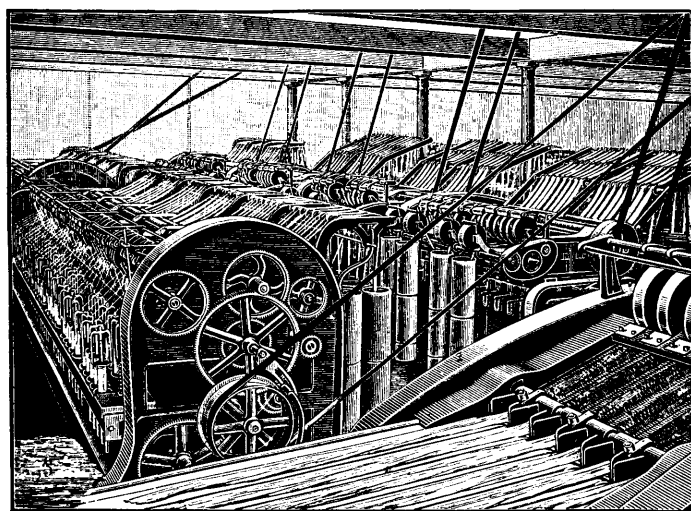


FIG. 350.

ing to drive the bobbins at the necessary speed, rising and falling regularly thereby, and thus causing the building of the roving onto the bobbin. The technical name for this motion is *builder*, and its speed per minute, and the revolutions of the bobbin, are made to vary as each layer passes on the bobbin; so that there may be no difference on the tension of the roving by the alteration in the circumference of the barrel as each row is added. The mechanism producing this motion is known as the *differential motion*, which has been thoroughly described in the chapter on cotton spinning.

**A Line System.**—By this we classify a certain number of machines as used in the preparing department, arranged and specially adapted to each other for the preparation of

a particular grade or quality of flax. The same may consist of one or two spread-boards, two or three drawing-frames, and one roving-frame. Each individual machine in a line system supplies the succeeding machine. The most frequently found arrangement is—one spread-board, one first drawing-frame, one second drawing-frame, one third drawing-frame, and one roving-frame; but, as mentioned, changes, with the exception of using one roving-frame, may arise, either by means of the material to use or the floor space in the mill. Fig. 350 is given to illustrate the working of a line system.

**Spinning.**—The spinning-frame, as used for converting the roving of flax or tow into a thread, is also nearly related in its principle of construction to the fly-throstle as used for spinning cotton yarns. The *throstle* principle is the one most generally used, yet in some places mule spinning is introduced. Two different systems of throstle spinning are in use—the wet spinning and the dry spinning processes.

**Wet Spinning.**—Like the spinning of all the other materials before the invention of spinning machinery, flax was spun by hand, being a home industry, and was generally performed by the

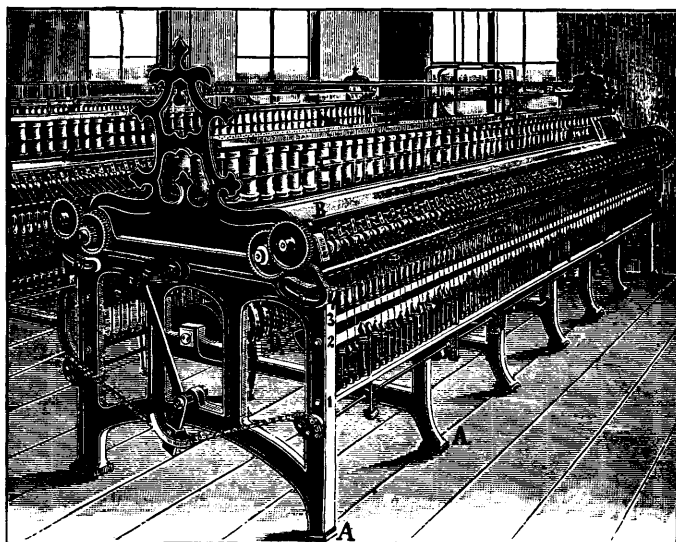


FIG. 351.

housewife or her daughters. In doing the work the *spinsters* used to moisten the fibres with their saliva to make them adhere to each other, also to make them more pliable and easy to twist. In imitation of this old-fashioned practice, the flax fibres were wet in cold water previous to their spinning; but at present warm water, of about 120° F. is used. This softening of the flax fibres is based on the fact that flax fibres are, comparatively speaking, perfectly inelastic, for when dry they cannot be stretched beyond the  $\frac{1}{10}$  or  $\frac{1}{15}$  part of their original length without being ruptured; but when softened in hot water (the fibres increase in diameter, and consequently in length) their elasticity is raised to about  $\frac{1}{5}$ , in addition to which they are rendered more adhesive to one

another, and will lie closer in the process of twisting. Fig 351 illustrates a *wet spinning-frame* for line and tow. It is oblong in shape, being built on a structure of supports (see *A, A*), two or three feet apart, and used in a number regulated by the length of the machine. Situated transversely to the supports are the sides of the frame, composed of two horizontal rows of rails (see 1 and 2), situated parallel, one above the other. These sides, with the help of the beam of the frame (set slightly backwards, but horizontal to the rails) bind or hold the supports of the frame together, and complete the framework of the machine. The rails form the supports for the vertical spindles, which revolve at great speed (4,000 to 6,000 turns per minute) to enable the yarn passing through the eye of a flyer, as screwed to the top of each spindle, to be properly twisted before being wound on the bobbin which revolves on the spindle, and under the flyer (see 4). The lower end of the spindle, called the *spindle foot*, works in a brass bush inserted in the lower rail (see 1), called the *spindle step*. The *spindle neck* works in a brass bush set in the upper rail (see 2), and is commonly called the *neck*. Running parallel to the two sets of rails, and between them, in the inside and extending throughout the full length of the frame, is situated a tin roller *D*, having a diameter of about 10 to 11 inches. This tin roller revolves on an iron axle, bearing on seats cast in the centre of the two outside supports of the frame. The *spindle bands* pass around the tin roller, and thence to the *whirl* (a small iron grooved boss, see below Fig. 2) of the spindle;



consequently the great surface speed of the cylinder is communicated to the spindles. One end of the cylinder axle is extended outside of the one end-support to allow a small wheel, *cylinder pinion*, to be fastened on, and which gives motion to the rest of the gearing. Outside the cylinder pinion a pulley is fastened to the elongated axle of the cylinder, and which is, in the common manner, by means of a belt, connected with the respective driving wheel as situated on the driving shaft of the room. As long as the driving shaft is revolving and the belt is left on the keyed pulley of the spinning-frame, so long the latter remains in motion; hence a loose pulley is placed close to the keyed one (and on the same shaft), to permit the shifting or guiding of the belt, by means of the belt fork, from either pulley to the other, producing respectively a starting or stopping of the machine. The entire length of the spindles varies from 14 to 24 inches, according to the kind of material to be spun; thus the upper and lower rails of the frame are also the guides for the spindles, and must be set a proportionate distance apart. That part of the spindle which extends clear of the upper rail of the frame is called the *spindle-blade* (see 4) and over it is let down the *builder* (see 3). The bobbins containing the roving are arranged in two parallel creels extending along on the top of the machine (see *C*). One creel supplies each side of the spindles, and since no doubling process takes place, one bobbin is required for each spindle. From the bobbins on the creel the roving ends are passed through a shallow wooden trough situated over the entire length of the machine (see *B*) from which they are drawn by and between a pair of rollers called *top-rollers* or *feeding-rollers*, the bottom one of which is made of iron covered with brass, fluted horizontally and has a positive drive, whereas the top one is made of box-wood and with flutes similar to those of the iron rollers. These wooden rollers are pressed by means of leverage to the former, hence revolve by means of frictional contact. In a certain distance apart from the top-rollers, as regulated by the material to be used (line or tow, or finer or poorer qualities of either) a similar pair of rollers called *bottom-rollers* or *delivery-rollers* are arranged, but which revolve at a much greater speed. The difference between the speed of the top and bottom rollers is regulated by the difference as to counts between the roving and the spun yarn required. The distance between the top and bottom rollers is called the *reach*. The flutes in the top and bottom rollers are to hold the roving firm during the drawing operation, *i. e.*, insure perfect work. From the bottom or delivery-rollers the drawn out roving passes to a flyer and spindle, which in many points, only in a reduced size, resemble the same parts in a roving-frame. Leaving the bottom of the *flyer-leg*, the thread passes to the bobbin, which fits loosely on the spindle, and round which it is wound by the rotation of the spindle. In diagram, Fig. 352 we show the difference in setting a frame for spinning either warp yarn or filling yarn (or hard or soft twist yarn). In this diagram the solid lines represent the frame set for spinning warp, whereas those dotted show the set of the same frame for spinning filling yarn. Examining the illustration closer we find that the amount of projection of the *line* depends also on the width of the flyer, hence if dealing with poor yarns we must use narrow flyers and correspondingly narrower bobbins so as not to bring too much strain on the yarn, which may be caused either by greater projection of the line above the thread plate eye, or the increased diameter of circle inscribed by using a large flyer. Both points must be taken care of if changing the spinning from warp to filling since the simple changing of the flyer would go only a small way to fit that frame for the required change in work. As before mentioned the average temperature of the water in the troughs is 120° F., but it must be understood that not all yarns spin best with this temperature. Poor filling yarns frequently spin best with the water at a temperature of 90° F., but in no instance should we raise this temperature above 160° F., since if heating the water above the mark it will boil out of the material too much of its saliva or nature, and the cloth produced out of such yarn will get a rough, cheap, coarse, cotton-like appearance.

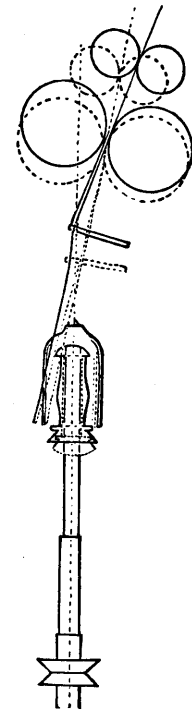


FIG. 352.

**Dry Spinning-Frame.**—As previously mentioned, wet spinning of flax and tow allows us to produce a very fine thread in counts but we have to remember that this is done to some extent at the expense of the general appearance of the cloth, whereas in the dry spinning-frame the so greatly valued silk-like appearance of the flax fibre is retained for the cloth produced out of such yarn. Fig. 353 illustrates such a dry spinning-frame which in its principle of construction differs only in not having the characteristic water troughs, hence the creel containing the roving bobbins is situated handier, *i. e.*, more in front or closer to the delivery-rollers. The draft in this machine is less compared to the wet spinning-frame for reasons previously given.

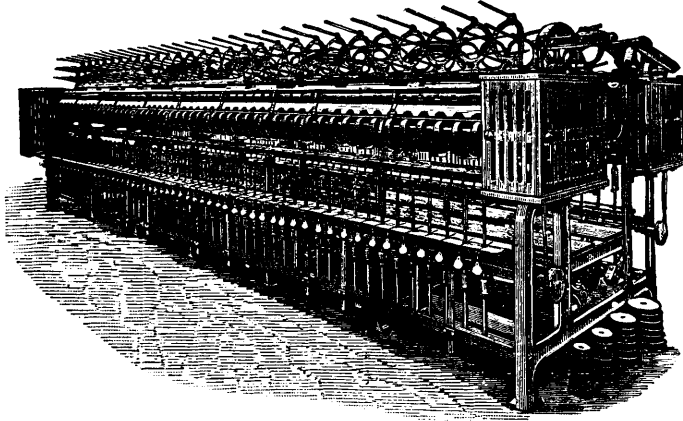


FIG. 353.

for line or tow. The average amount of drawing for the first kind of yarn is from 7 to 8 times its roving length, whereas for tow it is from 6 to 7 times its roving length. In spinning tow the flyers are arranged to revolve about 1,000 revolutions per minute less than if spinning line. Explanations given previously (regarding projections of line, as well as size of flyers to use) regarding spinning poor yarns, will be also worthy of consideration if changing the spinning on the same machine from line to tow, or *vice versa*.

**Reeling.**—The yarn, after leaving the wet spinning-frame, must be dried as quickly as possible, so as to prevent any possible blue-molding and decaying. When the bobbins on the spinning-frame are full of yarn the operator takes them off, placing them in boxes, to be carried to the reeling department (see Fig. 354), where a number of those bobbins are put at once on a creel situated on top of the machine, and are re-wound in hanks and then dried, either in the air or by means of a drying machine. If using the latter process (drying by

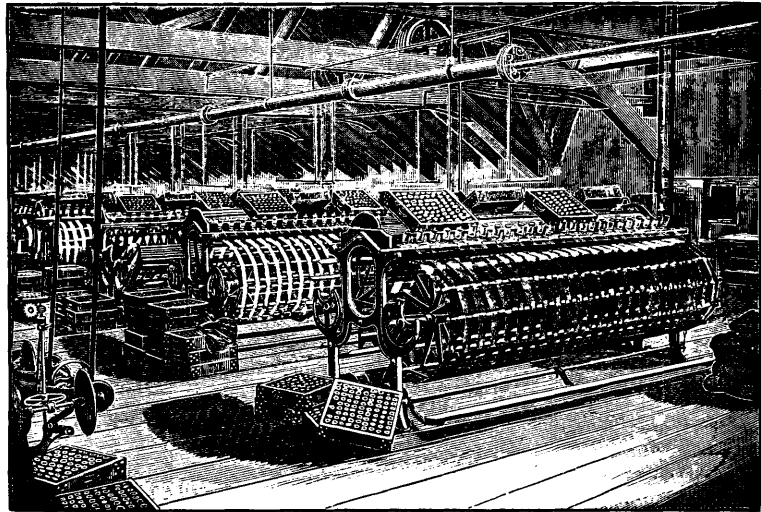


FIG. 354.

machine) the yarn must be placed, after being perfectly dried, in a *cooling shed*. This cooling brings back the over-dried portions of the yarn to the normal temperature, restoring strength and the silky appearance to the fibres. The yarn leaving the dry spinning-frame is also reeled, so as to have the bobbins empty, but requires, as is readily seen, no drying. The yarn from either kind of frame, after being reeled, is ready for bundling or bunching, and is put in bunches of any size, according to the size of the yarn presses or the special wishes of the manufacturer.

## Jute.

Jute is the name for the bast fibres of *corchorus olitorius* and *corchorus capsularis*, belonging to the family of the *Tiliaceæ*, which are largely cultivated in India and China. The material is used in the manufacture of carpets, rugs, upholstery fabrics, trimmings, etc.; for the manufacture of the gunny-bags so extensively used for packing cotton, rice, and other articles. The fibre is separated from the plant by processes similar to those employed in obtaining the flax fibre; *i. e.*, retting, beating, washing, drying, etc. Under cultivation, the jute plant grows to a height of six, eight, or ten feet, attaining in rich soil a height of from twelve to fifteen feet. Its stem is straight and smooth, with an average circumference of one inch. This stem throws out lateral branches, depending in number (similar to the flax plant) upon the degree to which they are crowded by neighboring plants. Most of the jute is obtained from the species known as *Corchorus capsularis*, and of which we give an illustration in Fig. 355.



FIG 355.

cylindrical fibrils, having irregularly thickened walls, and a comparatively large central opening.

**Color.**—The color of the fibre varies from brown to silver gray, and is distinguished from flax by being colored yellow, under the influence of sulphuric acid and iodine solution.

**Place of Growth.**—The jute plant can be raised in any country having sufficient warmth and moisture, but, as previously mentioned, it is cultivated mostly in India (Bengal), and somewhat in China. Its best place for growth is in the alluvium in the deltas of rivers, and less on the higher situated parts of the country, a rich loam being the most suitable ground for cultivating the jute plant, which is produced by the overflowing of rivers. The time for sowing the seed is March or April. The fields are weeded after the plants attain a height of about one foot. If planted for the use of the fibre, they are cut down during August and September, tied up in bunches and ready for the steeping, beating, washing and drying processes. After drying they are cleaned and tied up into bundles for the market. In this state they are bought by dealers, forwarded to Calcutta, where they are made up, by means of hydraulic presses, into bales of an average weight of 375 pounds each and shipped to Europe or this country.

**Jute Spinning.**—Pressing the jute into bales by means of powerful presses causes streaks which are very hard, and render it rather difficult to be opened and reduced to a workable dimension. In some mills the bales are placed under a steam hammer, and subjected for a short time to a beating

**Fibres Magnified.**—Examining jute under the microscope (see Fig. 356) shows it to consist of bundles of stiff, lustrous,

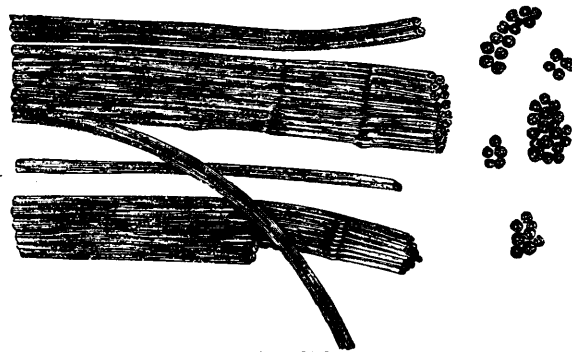


FIG. 356.

process. Other mills use in place of it what is termed a *crushing machine*, which is illustrated in Fig. 357 in its top view, and in Fig. 358 in its section. Letters of reference in both illustrations are corresponding, and are as follows: *A*, the crushing-rollers, having on one-half its length blunt teeth, and on the other half a fluted surface. The lower situated set of rollers are arranged reversed to the upper set; *i. e.*, where we find teeth in the upper set, we have grooves in the lower, and where we find grooves in the upper, we have teeth in the lower. The purpose of these rollers is to

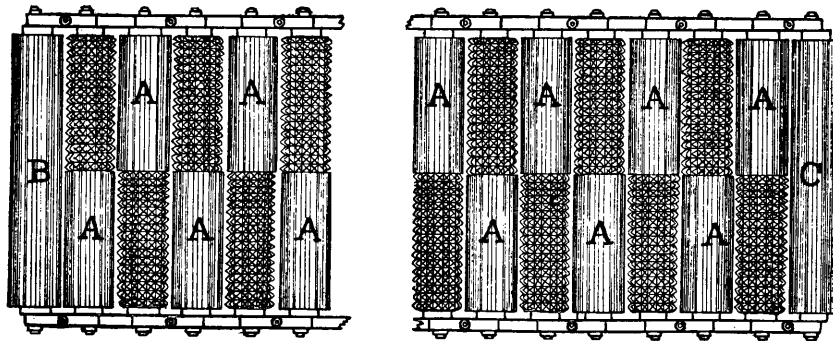


FIG. 357.

press, by means of the teeth of the rollers, the strands of the fibres into the correspondingly situated grooves, and thus split the same. Since a great many of these pairs of rollers are used in a machine, it will be readily seen that each strand is separated in its lowest constituent of fibres when leaving the machine. *B*, are the feeding-rollers, being simply a pair of rollers grooved over their entire surface. Their work consists in feeding, in proper amounts, the raw material to the previously alluded to sets of working-rollers. *C*, are what is called delivery-rollers (constructed similar to the feeding-rollers) which

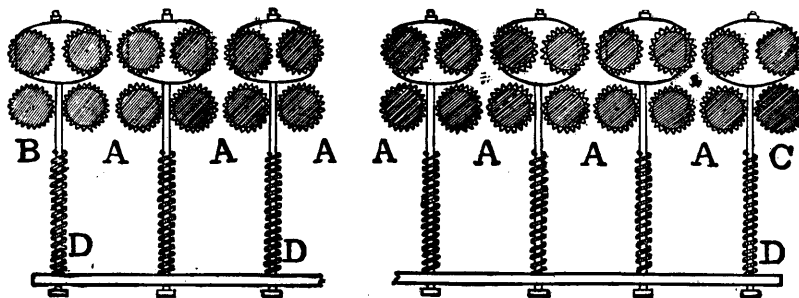


FIG. 358.

have for their object to take off from the workers the prepared fibres ready for future processes. Springs *D*, are the means for compressing the correspondingly situated rollers, also allowing the expansion of some of them if some of the strands fed into the machine are too thick.

**Softening.**—The nature of the jute fibre requires it, prior to being crushed, to be subjected to softening, *i. e.*, spread over with oil and water or some other suitable substance for making it more pliable. The amount of water to be used varies according to the nature and quality of the material, the counts of yarn into which it is to be spun, temperature and state of the atmosphere, and the time and mode of application, whereas the oil as used does not vary as much in quantity as quality, *i. e.*, using for the lower grades of the material a cheaper oil and for the finer grades a better oil. Whale and seal oil mixed with mineral oils for cheaper grades of yarns are mostly used; both water and oil being heated to about 100° F. There is quite a difference in the fibre between the root end and the crop end of the jute plant, hence it is rather difficult, if not impossible to soften both ends alike with the same operation, since if softening the root end sufficiently, the crop end (being softer in its nature of growth) would be materially damaged. Again if suiting the softening to the crop end, the root end will not get suffi-

ciently pliable to permit good work during future operations. This will explain the reasons for the great diversity of opinions as to the proper amount of softening the different grades of jute require. Great care must be exercised to distribute the oil and water equally over and throughout the entire lot of jute. To gain this purpose batches of from 10 to 12 by  $3\frac{1}{2}$  to 4 feet are formed. The streaks forming the bale must be divided, using great care when laying them in rows to have the heads, *i. e.*, where the piece is doubled, placed evenly. After laying each row, first a portion of the oil and then a part of the water is always distributed over it by means of a can. When the batch is completed it should be covered with a cloth to prevent the heat from passing quickly off. Some of the crushing machines are arranged to permit a softening automatically (adding of oil and water) during the operation. The crushing machine generally contains from 26 to 36 pairs of rollers, the water being generally applied about the second or third pair of rollers and the oil about the fifth or sixth pair. Some of the machines are arranged to distribute the oil and the water in the centre of the machine, permitting the first rollers to clean off any loose root. The oil and water as used for softening are heated either by steam pipes passing through the liquids, while in others the oil cistern is heated by being placed inside the one containing the hot water. By means of suitable arrangements the amount of oil and water can be easily regulated.

**The Preparations Most Frequently Used for Softening are :**

*For Fine Yarns*, per bale of 350 lbs. Mix  $\frac{3}{8}$  gallon whale oil,  $\frac{3}{8}$  gallon seal oil,  $\frac{1}{4}$  gallon mineral oil, and 6 to 7 gallons water. Another mixture is as follows: Mix  $\frac{1}{3}$  gallon whale oil,  $\frac{1}{3}$  gallon seal oil,  $\frac{1}{3}$  gallon mineral oil, and 6 to 7 gallons water.

*For Coarse Yarns*, mix 1 gallon mineral oil with 5 to 6 gallons water, or  $\frac{7}{8}$  gallon mineral oil with from 5 to 6 gallons water.

If making up batches say 7500 lbs., use as follows: for fine yarns; Mix 8 gallons whale oil, 3 gallons seal oil, 3 gallons mineral oil and 100 gallons water, or use 5 gallons whale oil, 5 gallons seal oil,  $4\frac{1}{2}$  gallons mineral oil, 8 lbs. soap and 100 gallons water. If using the latter preparation mix the oils previously to the adding the heated water containing the soap mixed. The appearance of this preparation if properly mixed will be rich and creamy. Another preparation which is cheaper but apt to dirty the card clothing (if working jute tow) is as follows: Mix 6 gallons whale or seal oil or both mixed, with 10 gallons of mineral oil, 8 lbs. soap and 100 gallons water.

**Jute Line.**—The average length of the jute strand is from ten to thirteen feet. The reducing of these strands into its lowest constituent of fibres for the finest qualities is done on a similar built (hackling) machine, as is used for flax; and the product thus derived (by means of future operations) is known as jute line.

**The Hackling Machine** as used for jute is built somewhat stronger than the similar machine used for flax, since the jute plant in its nature of growth is correspondingly coarser and stronger than the flax. To facilitate the operation the jute strands are cut up in pieces in their length.

The succeeding operations are:

**Spreading, Drawing, Roving and Spinning**, the processes of which are the same as those explained for flax.

**Jute Tow.**—The medium and lower grades of jute as well as the coarse unsplit ends, which are found even in the finer sorts, are manufactured by means of carding, drawing, roving and spinning, into what is called jute tow.

**Carding.**—The object of this is to transfer the previously softened and opened jute strands into tow (similar to the tow made from the flax fibre). This work is done on the carding engines of which two machines, *i. e.*, breaker card and finisher card successively following each other in their operation are employed.

**Breaker Card.**—This is the machine to which the fibre is first submitted. The breaker card consists of the characteristic main cylinder or swift, several workers and strippers, doffer-cylinder and comb. As easily understood the clothing used for this card must be very strong, by reason of the coarseness of the fibre to be worked upon. The average surface speed of the swift is thirty-two feet, for the worker five inches, and for the stripper three feet per second. By means of cylinder, workers and strippers, the jute strands as fed in the machine get reduced to their lowest constituents of fibres as well as reduced to proper size in their length. When leaving the last worker, the properly split jute fibre is found evenly spread over the surface of the cylinder from whence it is taken off by the comb in the shape of a continuous film, which is guided by means of delivery-rollers upon an oblique table the shape of the letter *V* (see Fig. 359); *a*, in diagram indicates position of previously referred to delivery-rollers; *b*, and *c*, guides for table *d*. When the fibre arrives at the place indicated by letter *e*, in diagram, the same is taken off by means of a pair of conductor-rollers *f*, (and which constantly draw the baird off the table) delivering it in a single sliver for the finisher card. In spreading jute upon the feeding-table of the breaker card, the root end is spread first, and the distance the next piece has to overlap depends upon the weight of fibre in the crop end of the strand. Some difference between a jute card and a flax (tow) card is found in the feeding arrangement. The former machines contain a shell feeding-roller, whereas the latter cards have the regular or two feeding-rollers.

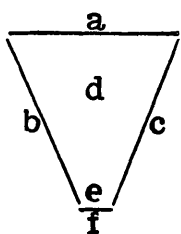


FIG. 359.

**Finisher Card.**—The sliver, as formed by the breaker card, is next supplied to the finisher card either in cans or made into laps or balls. The construction of the finisher card for jute is so nearly the same as the one used for flax (tow) that a special explanation of the same is unnecessary. Similar to the flax tow card the jute tow finisher card has for its main object the parallel arrangement of the fibres, so as to permit the succeeding operation of drawing out the sliver. The finisher cards for jute are *full circular* for the higher counts of yarn, and *half circular* for the lower counts. The first mentioned kind of cards deliver on the side where the feeding-roller is situated; whereas the latter mentioned kind deliver on the opposite side from the feeding-rollers. Half circular cards contain only two to three pairs of rollers (worker and stripper), whereas full circular cards have from four to five pairs.

**Drawing, Roving, Spinning.**—There is very little difference, if any, in these different processes as required for the spinning of jute tow as compared to the corresponding process for spinning flax tow (and which we thoroughly explained and illustrated in a previous chapter); consequently a special reference to either subject is unnecessary; in fact, the different machinery used for tow spinning being suitable for either. The counts to which jute yarns are spun are generally coarser than tow yarns made from the flax fibre; hence the machinery used in jute spinning is simply built heavier and coarser in its details.

## Ramie.

Ramie or *Boehmeria utilis* of which we give an illustration in Fig. 360 is a specimen of the nettle family *Uticaceae*. It is a native of East India, China and Japan, but at present experiments are being made rather extensively in our country's Gulf States (especially in the vicinity of New Orleans) to cultivate this fibre. The actual introduction of it in this country dates back to the year 1855. The plant when fully grown attains a height of from 4 to 8 feet, and is surrounded with large ovate acuminate leaves which are green above and whitish or silvery beneath, the fibre being formed in the bark surrounding the stalk which has a pithy centre. Similar to the China-grass, it is of a rapid growth producing from two to five crops a year (according to the climate and soil) without re-planting.

The method for obtaining the fibre as practiced by the natives in East India, China and Japan, is splitting and scraping the plant stems and then steeping them. As this method is very tedious, a machine and process is wanted to accomplish this labor quickly and automatically. The ordinary retting process, as used for flax, is not sufficiently effective, since the succulent nature of the stem and the great amount and acidity of the gummy matter rapidly coagulate, becoming insoluble on exposure to the air.

**The use of the Fibre.**—In East India, China and Japan where, as previously mentioned, the fibre is extracted by the natives by hand labor it is manufactured not only into cordage, nets and similar coarse fabrics, but also used for the construction of some of their most beautiful textile fabrics. On the European Continent and in England this fibre also has been woven into a great variety of fabrics, since it can be dyed in any color and rivals silk in brilliancy. Another feature greatly in favor of this fibre is its remarkable strength and durability, being also the textile fibre least affected by moisture. With reference to spinning, ramie can be used either alone or in conjunction with cotton, wool, silk or flax for the manufacture of such textiles where elasticity is not essential.

Ramie has three times the strength of Russian hemp, while its filaments can be separated almost to the fineness of silk. The average value of ramie, either imported (including transportation and duty) or American grown material, is 9 cents per pound.

**Its Cultivation.**—As previously alluded to, Ramie is in this country mostly grown in the vicinity of New Orleans; the Southern States, and especially such as border on the Gulf of Mexico, are the most favorable for its cultivation, yet the plant has also been grown as far north as Pennsylvania and New Jersey, and as far west as California. As to the cultivation of Ramie, the Department of Agriculture, in a report just published, has given the following directions: "The plant is propagated by seeds, by cuttings or by layers, and by division of the roots. When produced from seed the greatest care must be taken with the planting, as the seed is very small. For this reason open air planting can hardly be relied upon, plants started in the hot bed giving the best results. After planting, the seeds are covered thinly with sifted earth and kept shaded from the sun until the young plants are 2 or 3 inches high, when sunlight must be gradually admitted to them. In five or six weeks they will be strong enough to transplant to the field.

In the East Indian method of propagating by cuttings of the stems, the spring grown stems are used and when fully ripe. Only the well ripened portion where the epidermis has turned brown is employed, the stem being divided into lengths that will include three buds, care being taken to cut a quarter of an



FIG. 360.

inch above and the same distance below the top and bottom buds. These are planted with the central bud on a level with the soil. The cuttings are shaded for ten days or more unless the weather be cloudy or rainy. In India the cuttings are planted a foot apart, although given more room as the plants mature. By far the most practical method and the one which will give the best results in this country is a propagation by the division of the roots of old or fully matured plants. The old plants are better than young ones for the purpose, as the root mass is larger, the tuberous portions showing a greater number of eyes and therefore giving stronger plants after division. The practice varies as to distance apart that these are planted. In India four feet apart each way is considered the proper distances though in France some favor two feet apart each way as giving better results."

In a former report on the culture of ramie issued by the Department of Agriculture these directions are given: "Furrows five or six inches deep, and five feet apart are opened with the plow. The roots are laid lengthwise in the middle, close in succession if a thick standing crop is desired, but placed at intervals if nursery propagation is the object in view. The first mode will absorb 3,000 roots per acre, but will save the labor of often filling the stand by propagation.

"The plants are given cultivation at first, being hilled like corn or potatoes, all weeds being kept down, though after getting a good start from the rankness of their growth and the density of the foliage, weeds will have little chance to grow.

"A rich loam suits the plants best, but they will grow in any kind of soil, provided a full supply of moisture be available, combined with thorough drainage.

"If sufficient moisture cannot be assured it should be supplied by irrigation, a positive necessity in many localities where ramie is grown. However, it must be remembered, that ramie will not thrive in a wet soil. The ground must be well prepared by plowing to the depth of ten inches, and well pulverized, and if the land is poor, fertilizers must be applied to bring it up to a good state of fertility. All weeds must be removed from the soil or they will sorely plague the cultivator in the first year or so until the plants have grown large. When the climate will permit of producing three crops a year the cuttings are made at intervals of about ten or twelve weeks, the first cuttings to be made about the middle of May, dependent on the season."

**Status of the Ramie Industry.**—No doubt it has been clearly demonstrated both in this country and in Europe that ramie is and can be manufactured in an endless variety of textile fabrics, yet the disadvantage (as previously referred to) of not having a real practical chemical process or machine for decorticating the raw fibre (producing the cleaned fibre as required for spinning from the stalks as harvested) is a serious drawback so far. No doubt hundreds of processes and machines for doing this work have, in the last 30 years, been patented in the different countries more interested in this fibre, yet the proper process is as yet wanting. This feature will readily explain why ramie is not grown very extensively in this country. It is an important industry in China, Japan and East India, also in a very limited amount, in parts of Southern Europe, the French Colonies in Africa, in some of our South American Republics, and in the British Colonies. The fact of not having the proper means for decorticating the stalks, has thus far been a serious impediment to its commercial demand which at present is yet very limited, the present supply of cleaned fibres being so changeable and uncertain that manufacturers do not feel inclined to invest their capital in factories and machinery, but had this fibre a good decorticator this hinderance to success would readily disappear, and ramie take an equal value and place of importance among cotton, wool, silk and flax, as a fibre for textile fabrics.

The first machine for decorticating ramie in our country was patented by a Dr. Benito Roedel, September 17th, 1867, and it is said that hundreds of them were made at a foundry in New Orleans the succeeding year and offered for sale at \$225.00, but very few found buyers.

The editor of the "Bulletin of the Royal Kew Gardens" lately expressed

**England's Opinion on Ramie** as follows:—"In order to understand the present position of the ramie industry it would be useful to adopt some kind of classification of the details connected with it. In the first place we have the mere business of cultivating the ramie plant, and of producing stems with



the fibre in the best possible condition. This is purely the work of the planter. Secondly, we have the process or processes necessary to separate the fibre from the stem in the form of ribbons and filasse. It is necessary for many reasons that this should be done either by the planter on the spot or by a central factory close at hand. Thirdly, we have the purely technical and manufacturing process in which ramie filasse is taken up by the spinners and utilized in the same manner as cotton, flax and silk are utilized for the purpose of being made into fabrics.

“For our present purpose we may take it for granted that the cultivation of the ramie plant presents no insuperable difficulty. Also, that if a suitable selection of soil is made, and the locality possesses the necessary climatic conditions as regards heat and moisture, there is no reason to doubt that ramie could be grown, to greater or less extent, in most of our tropical possessions. As regards the second stage, in which is involved the decortication of the ramie stems, the problem is by no means completely solved.

“On this really hangs the whole subject. The third stage is disappointing and unsatisfactory, because the second stage is still uncertain; and being thus uncertain, the fibre is necessarily produced in small and irregular quantities, and only comes into the market by fits and starts. It would appear that ramie fibre differs so essentially from cotton and flax that it can only be manipulated and worked into fabrics by means of machinery specially constructed to deal with it. Owing to the comparatively limited supply of ramie fibre hitherto in the market, no large firms of manufacturers have thought it worth while to alter the present or put up new machinery to work up ramie fibre. If appliances or processes for decorticating ramie in the colonies were already devised, and the fibre came into the market regularly and in large quantities,—say hundreds of tons at a time—there is no doubt manufacturers would be fully prepared to deal with it. At present the industry is practically blocked by the absence of any really successful means of separating the fibre from the stems and preparing it cheaply and effectively. This, after all, is the identical problem which has baffled solution for the last fifty years.”

Before closing the subject on ramie (the future fibre for textile fabrics), it will no doubt be of great interest to the student to have a short description of the latest styles of machines and processes in use in this country and Europe for decorticating the stalks.

**Machines and Processes for Decorticating Ramie, as Exhibited at the Late Paris Exposition.**—The ramie, and its method of decorticating, attracted great attention at the late Paris Exposition. Several countries which took part in the Exposition sent specimens of fibre to show the result of experiments or progress of its own culture, or sent representatives to ascertain the latest facts on this fibre. Our country made also a small display of the fibre, illustrating the fact that the plant can be grown successfully here. Amongst the machines and chemical processes entered for decorticating the plant were the *Favier Machine*, in two forms (one for green and one for dry stalks); two forms of the *Landthsheer Machine* (one large and one small), the *Armand Barbier Machine*, and the *Felician Michotte Machine*, and the chemical process of *Ch. Crozat de Fleury et A. Moriceau*, for the treatment of stems in green condition.

**The Favier Machine** consists of two compartments which may be used separately or in unison. The first slits the stem or stalk either entirely or nearly through, flattening it into two bands. The stem being fed by hand to two vertical feed-rollers, which pass it through a tube, provided with a slitting knife, which is shaped that the slit is opened out. Flattening rollers next receive the stems, crushing them, the wood and bark however, maintaining their layer-like position. Next the stems pass into the second compartment where rollers with wide grooves, take hold of these ribbons, (or layers of wood and bark) breaking the wood into short pieces of about  $\frac{1}{4}$  of an inch in length which drop away leaving the bark intact, which is then subjected to a series of rubbing and beating rollers, manipulating the ribbon on both sides, removing the pellicle and thus disintegrating the fibre which is produced thoroughly clean and straight within two seconds from the time the stem leaves the attendant's hands.

The working capacity of this machine is as follows: 100 kilograms of green stalks have been passed through the machine in twelve minutes, corresponding to 500 kilograms an hour, or 5,000 for ten hours; and this with but two workmen employed. It is claimed that four workmen can decorticate 7,500 kilograms in ten hours.

**The Landtsheer Machine** is composed of three cylinders tangent to another central cylinder. The feeding cylinder is arranged with spiral grooves to regulate the feeding of the ramie stalks. The crushing cylinders are alternately smooth and grooved longitudinally in such a manner that when working together the grooved part of one bearing upon the smooth part of the other crushes the stalks. These cylinders are held in place by springs. After leaving the crushing cylinders the broken stalk passes between a pair of beaters, each supplied with sixteen winglets geared in such a manner that they lightly interlock, this action brushing off or removing the woody matter and the bark.

This machine is built in two sizes, known respectively as large and small machines. Trials of decorticating ramie upon either machine resulted as follows: 36 kilograms of stripped green stems were decorticated on a large-size machine in 2 minutes and 35 seconds, yielding 10 kilograms of wet ribbons. This was in two lots of 10 kilograms without leaves, and 26 kilograms with the leaves. In a second trial on the same machine, 46 kilograms of green stalks with leaves (200 stems) were cleaned in 11½ minutes, yielding 15 kilograms of wet ribbons, filled with fragments of woody matter, chips, and even short sections of stems, which were next passed through a small machine in 6½ minutes, giving in return 10½ kilograms of clean, wet ribbons. A third trial, using a small machine, resulted in decorticating 24¼ kilograms of green stalks with leaves in ten minutes, yielding 6½ kilograms of ribbons. Experiments with dry stalks on a large machine resulted in decorticating 30 kilograms in 21 minutes, yielding 10 kilograms of flat ribbons, the outer pellicle not being removed.

**The Armand Barbier Machine.**—This machine is quite simple and very similar to the Landtsheer Machine previously explained. The dry ribbons produced are broad and flat and none of the outer pellicle is removed. The refuse with the material comes away in large pieces and a considerable percentage of the fibre itself is whipped or torn off and falls with the refuse of decortication.

Trials with this machine resulted in decorticating 10 kilograms of stripped green stalks in 6 minutes, yielding 1¾ kilograms of wet ribbons. In a second trial, 24 kilograms of green stems, including leaves, were operated on in 10 minutes and 30 seconds, yielding 1½ kilograms of wet ribbons. Experiments with dry stalks resulted in decorticating 12 kilograms in 30 minutes, producing 2½ kilograms of ribbons.

**The Michotte.**—This machine is composed of four crushing rollers (having a special form of fluting) of large size, which are followed by a steel breaker with elastic beaters working in connection with another breaker of similar form. The first mentioned large rollers after crushing the stems next pass the same to the beaters for freeing them of the wooden part of the fibre.

In a trial, 17¾ kilograms of green stems with leaves were decorticated in 2½ minutes, yielding 6 kilograms of ribbons.

**The Fleury et A. Moriceau** process consists in simply immersing a quantity of ramie stalks (either dry or green) in a rectangular galvanized iron tank of boiling water set upon masonry to admit of fire beneath, to continue the boiling for a certain time, varying from five to fifteen minutes. The stripping of the ribbons is performed by hand by two men with occasional outside assistance. This process is of little advantage as it is too laborious and the production too small for the amount of time consumed.

**An American Machine for Decortication.**—A decorticator for ramie, which is the latest American invention of such a machine, is shown in Figs. 361 and 362. The invention consists in the combination of pressing and decorticating cylinders, brushes for cleaning the cylinders and the fibre,

and an automatic feeding arrangement by means of which the raw material is continuously supplied to the decorticating apparatus. Fig. 361 is a plan view and Fig. 362 is a side elevation of the same. Similar letters of reference indicate corresponding parts in both illustrations. The method of operation of the machine is as follows: The stalks to be treated are laid upon the apron *N*, and carried forward to the fluted crushing-rollers *L*, which crush them and deliver them to the steel points *b*. The crushed fibres are drawn between the points by the action of the teeth *T*, and the beaters *U*, carried by the cylinder *D*. The fibre passes under the cylinder *D*, is carried forward by the teeth and beaters on the cylinders,

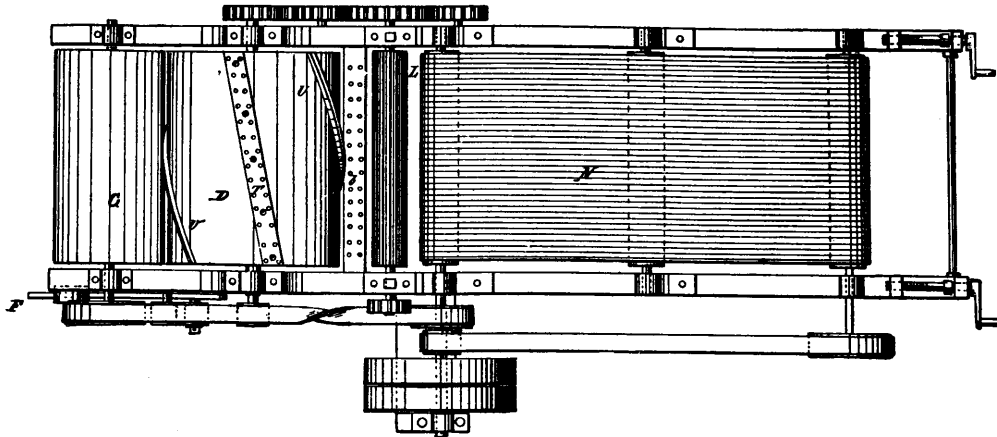


FIG. 361.

and is brushed by the rotary brush *E*, which revolves with a greater peripheral speed than cylinder *D*, and removes the greater portion of the dust adhering to the fibre. It is further treated in a similar manner by the brush *F*, and the dust removed by the brushes *E*, *F*, delivered to the table *R*. The cleaned fibre is carried upward by the cylinder *D*, until it reaches the brush *G*, when the fibre is removed by the action of the brush *G*, assisted by the natural tendency of the fibre to spring toward it, and delivered to the table *S*, in a thoroughly cleaned condition. The brushes *E*, *F*, not only clean

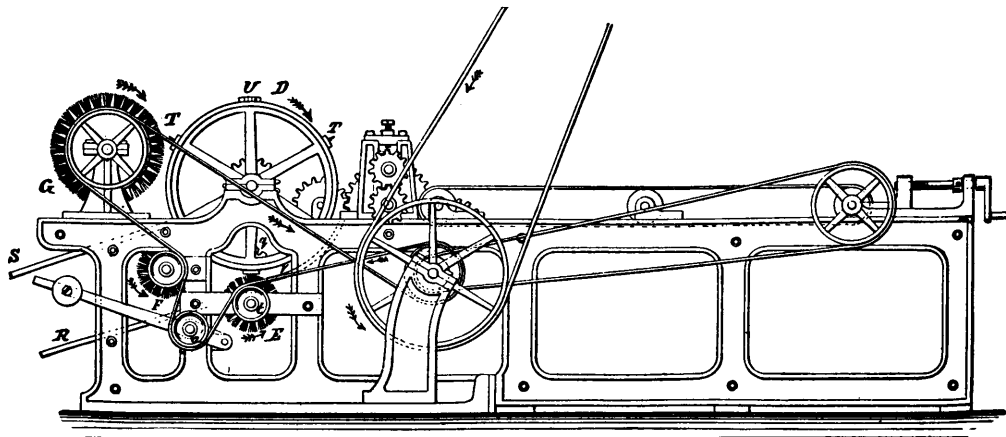


FIG. 362.

the fibre, but assist in retaining it on the cylinder until it is removed therefrom by the brush *G*. The fibre is held against the cylinder *D*, by the teeth *b*, and the concave *V*, leading from the teeth to the first cleaning brush *E*. The stalks thus treated are seven feet in length or longer, and the machine is so constructed that the front ends of the stalks will reach the brush *G*, before the rear ends are disconnected from the points *b*. The points *b*, do not hold the stalk so firmly as to prevent the cylinder from drawing them therethrough, but serve to retard the passage of the stalks, so that they will be thoroughly treated throughout their entire lengths, as described. The front ends of the bent fibre,

after being carried above the table *S*, will naturally project toward the brush *G*, and this tendency is assisted by the centrifugal action of the cylinder *D*, and the brush *G*, will therefore effectually prevent the cylinder *D*, from carrying the fibre around with it and delivers the same to the table *S*, as before stated. This decorticating machine can also be used for china-grass, jute or hemp.

**Spreading, Drawing, Carding, Spinning.**—In Europe, ramie has been worked almost entirely upon machinery as used for the manufacture of linen yarns. Lately experiments have been made there, as well as in our New England States, to use the regular woolen and cotton machinery for shorter fibres as well as the waste caused by drawing. If using the latter system of manufacture of yarns the degumming is only carried to the point where a filasse is produced which, when separated and broken in its length on a Fearnought, is sufficiently soft and pliable to be worked well on the woolen

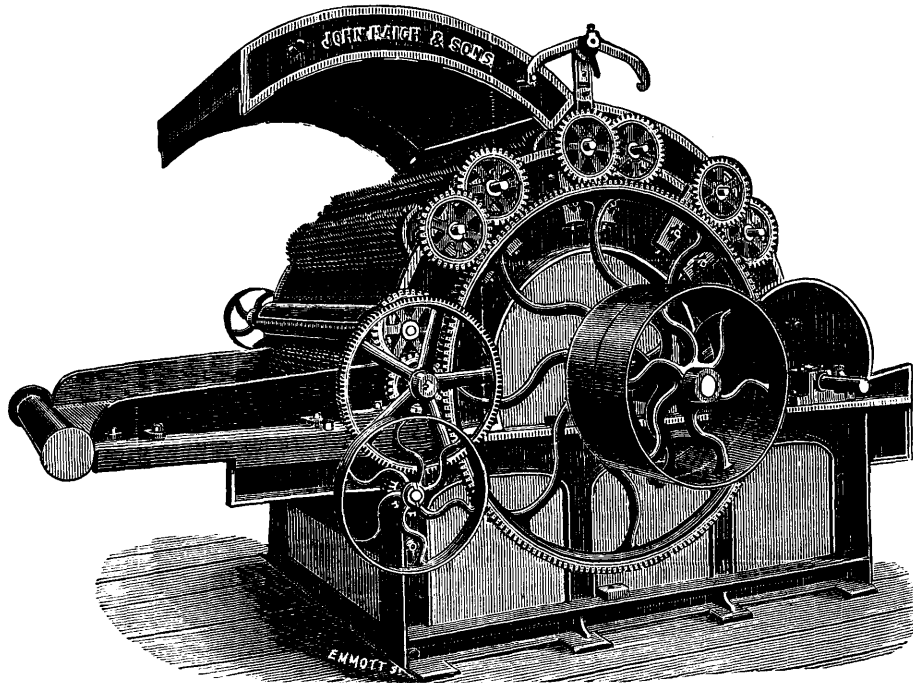


FIG. 363.

or cotton card. An illustration of a *Fearnought*, as built by John Haigh & Sons, is given in Fig. 363, being their regular machine used for opening, mixing and blending wool, and consists of two feed-rolls, one cylinder, with seven rollers over same, which are all steel-toothed, except the first, which is a brush roller. Grates are under cylinder and fan.

The average value of these ramie yarns in the gray is from 75 cents to \$1.00 per pound, and \$1.50 to \$2.00 per pound when colored.



## China-Grass.

China-grass (see Fig. 364) belongs to the same family of plants as ramie, and grows extensively in China, Japan and East India. It consists of the bast cells of *Boehmeria nivea*, belonging to the nettle family *Uticaceæ*. The separated and bleached fibre in appearance resembles silk (similar as the ramie) and is pure white. In Fig. 365 we give the fibre as visible under the microscope. China-grass, as previously mentioned, and as is also indicated by its name, is most extensively cultivated in China, where the yearly production amounts to (100,000,000) one hundred million kilograms (equal to 220,462,000 lbs.). There it is grown on plantations, which remain fertile from seven to eight years. The green stalks are cut as soon as about four feet high. Four to five crops are raised each year, the remarkable fact being that the frequent cutting of the stalks improve their fineness. The fibre as produced by means of splitting and scraping and successive steeping of the stalks, is performed by the natives by hand, and is of great strength, but owing to the slow and tedious process, only a limited amount of the thus prepared fibre is obtained.



FIG. 364.

The process of *decorticating*, or *retting*, by machinery is similar to ramie, and which has been thoroughly described in the previous chapter.

After opening the bale in which the raw material has been shipped from China, its contents are sorted according to length, color and quantity, then the respectively wanted lot is subjected to the breaking process; *i. e.*, broken by means of grooved iron rollers moving forward and backward. Next the material is soaked for some time in an alkaline bath, from which it is delivered to large air-tight kettles, being boiled under the pressure of several atmospheres. From there it is again removed, receiving several baths containing various chemical compositions, according to kind, at different temperatures, and is next submitted to a treatment with chlorine-ether and sulphur vapors. All these chemical processes have for their object the solution of the resinous and gummy matters, thus softening and dividing the material into its lowest constituents of fibres. After finishing these chemical processes, the long fibres are subjected to spreading, drawing, roving and spinning (similar as the process of preparing linen yarns) whereas the short fibres are treated similar as tow yarns.

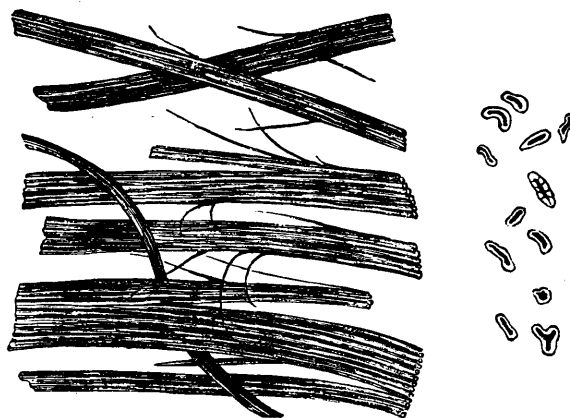


FIG. 365.

## Hemp.

The hemp plant (*Cannabis sativa*) is supposed to be a native of India, but has long been naturalized in Europe and this country. Fig. 366 gives an illustration of the plant, and Fig. 367 illustrates stalks, magnified. The average height of the plant is from six to eighteen feet, according to the soil and place of growth. Climate has much to do with the successful cultivation of this plant, as it makes the best length of stalks, and, therefore, gives a greater yield of fibre in countries where the climate is mild and the atmosphere humid. Limestone soils, or the alluvial soils, as found in the river bottoms, are most congenial to its growth.



FIG. 366.

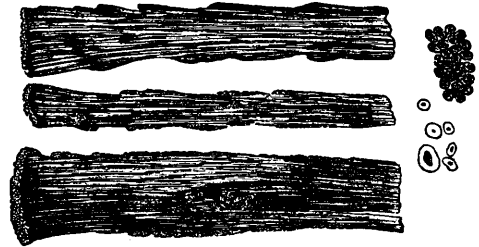


FIG. 367.

**Place of Growth.**—The best hemp comes from Piedmont, Italy, although only very little of it comes into this market.

The only hemp which comes into direct competition with the best of American is the Russian, but the former possesses greater flexibility, and can be dressed finer, although the Russian is more equal in length.

**Best Method of Cultivation.**—In the cultivation of hemp, high fertilizing is necessary, as hemp absorbs the equivalent of 1,500 pounds of fertilizer for every hundred pounds of fibre obtained. If the soil is not sufficiently rich in phosphates, or the salts of potassium, these must be supplied by the use of lime, marl, ground bone, animal charcoal, or ashes mixed with prepared animal compost. Leaves of the plant and *shives* may be returned with benefit to the land. There are two modes of gathering according to the use to which the fibre will be put. If for cordage, the stalks are cut with a sharp instrument (similar to a short scythe) and laid upon the ground in sheaves where they are left to dry from one to three days. Next the leaves are stripped, and the stalks removed to the sheds for sorting, placed in piles horizontally, the lower ends of the stalks being pressed firmly against a wall, so that the inequalities of their length may plainly appear. To prevent deranging the stems while drawing them out in assorting, a weight is placed upon each pile close to the wall. The drawing out of the stems from the pile is done by handfuls, commencing with the longest stems, taking the medium next, and finally the shortest ones. After sorting the stems according to length they are bound into sheaves, the tops of which are then cut off, and only the portion preserved that will make good fibre. Several sheaves are next put together, thus forming bundles.

If planting hemp for the manufacture of yarns, the stalks are not cut but are pulled like flax. The leaves are next removed by the farm hand so as to return the latter to the soil where grown. According to the ease with which they can be drawn out of the ground, from six to fifteen stalks are pulled at one operation. These handfuls are made into bundles about six inches in diameter; next the roots and tops are chopped off by means of an axe. The thus clipped stalks are made up in bundles of a foot or more in diameter and ready for retting immediately, as it is claimed that the hemp is not so white if it is dried before retting.

When the seed is saved the procedure is as follows: The male stalks ripen six weeks earlier than the female stalks; the latter are given plenty of time to mature, not being gathered until their leaves and stems begin to turn yellow and the seeds to grow dark. They are tied in bunches, and of these there

are made large bundles which are placed upright that the seed may complete its opening, which are extracted afterward by beating the stalks. This operation produces less fibre, and these female plants yield fibre of inferior quality from those collected at the time of maturing of the male plants, but the harvest of the seed compensates for the difference.

The next processes, as retting, scutching, hackling, as well as the different spinning processes, are similar to those used for flax.

**Retting.**—There are two kinds of processes in use for retting, *dew-retting* and *water-retting*. The first mentioned system is carried on in the open field, where the stalks are allowed to lie about a month. This is the process mostly practiced by the American farmers although manufacturers prefer water-retted material. The latter process is accomplished both in pools and in running streams. The retting in running streams accomplishes the best results, although requiring more time than pool-retting. The time of immersion varies from five to eight days, but if the weather is rather cool, it will retard the operation from one to three days, which also accounts, too, for the shorter time required for pool-retting. The pools as used, if pool-retting is the system employed, are dug to a depth of a yard or more, walled up or the sides made solid, and usually lined and floored with cement so as to keep the water clean, and the hemp retain its color. Care must be taken by the farmer against over retting, which will weaken the fibre. For this purpose, the stalks are watched very closely after the fourth day of immersion, the farmer, at intervals, pulling out a few and breaking them with his hands. After being sufficiently retted by either system, the bundles of hemp are agitated to remove all waste matter that may adhere to the stalks, which are next removed from the water, drained, the bundles opened at the bottom and set up in conical sheaves to dry, which is generally accomplished in two or three days. Henry Clay introduced into our country the water-retting process; but few farmers of the present day will undergo the trouble connected with the operation, although the practice would give better results by producing a better quality of material and return a better price; and as the total imports of raw fibre amount to some (\$44,000,000) forty-four million dollars per year, it is safe to state that (\$26,000,000) twenty-six million dollars could be saved to this country, or the farmers, by adopting water-retting. The best results as to the quality of fibre are obtained by gathering the plants when the male stalks have shed their flowers and the stems begin to get yellow.

**Power Breaker in use in this Country.**—The most frequently used of these machines is the one invented by Hartshorn. This machine consists of several pairs of fluted rollers, interspersed at intervals with peculiarly constructed scutchers, or cleaning rollers, which pierce the hemp with steel pins, and also beat, shake and scrape it vigorously, while it is held on either side by the breaking rollers. By reason of a more rapid motion given to the scutching than to the breaking rollers, the breaking, piercing, beating, shaking and scraping are all accomplished while the hemp is passing rapidly through the machine. The flutes are graduated from very coarse to fine, and the rollers are driven in such a manner that the stalks are not crushed, but broken by the most favorable leverage.

The coarser kinds of hemp are used for the manufacture of cordage, whereas the finer grades are used for textile purposes.

**Hemp Compared to Flax.**—Hemp though inferior in delicacy and fineness to linen, is incomparably stronger, equally susceptible of bleaching, and possesses more of the property of improving in color by wear. The finer grades of the fibre are spun in yarn and used extensively in the manufacture of carpets of all descriptions (hemp carpets, also stoffer warp for brussels, tapestry carpets, etc.)