

which rests upon the periphery of the yarn mass W^x on the beam. Beyond the loom side said rock shaft has fast upon it a second arm E^2 , rearwardly extended and upturned at its inner end and pivotally connected at e with the lower end of an upturned radius bar E^3 , bent to clear the pinion shaft B. The upper end of the radius bar extends between the members c and d of the pawl carrier, and is provided with a transverse stud e^1 , the opposite ends of which enter the guide-ways c^1 , d^2 of said members, respectively. The arms E^1 , E^2 form a bell-crank lever, and when the beam is full, the arm E^2 will be raised and the stud e^1 , which is the connection between the members c and d , will be at its highest point and the stroke of the pawl d^x will be governed by the throw of the member c . As the yarn is wound off, however, the diameter of the mass W^x constantly decreases, and the roll E^x will move toward the axis of the beam and the rear end of the arm E^2 will descend, so that the connection e^1 will move away from the fulcrum of the member c and toward the fulcrum of the member d , viz., the pinion shaft B. This results in increasing the throw of the member d , and consequently increases the stroke of the pawl, by setting its starting point farther back along the ratchet, so that a greater number of teeth will be delivered, although the throw or swing of the member c remains substantially constant. Thus while the movement of the whip roll remains substantially the same, the pawl will be set back a gradually increasing distance as the yarn winds off to compensate for the constantly decreasing diameter of the yarn mass. The shaft B has fast upon it the hub g^1 of an annular internal gear g , having eleven teeth and meshing with a gear of ten teeth loosely mounted on an eccentric hub g^2 fast on the ratchet B^3 , an arm g^3 having a longitudinal slot in its free end to embrace the rock shaft E, permits slight rocking and longitudinal movement of said arm.

A friction clamp cooperates with the ratchet B^3 , the latter having fast upon its outer face a peripherally-flanged hub b^x , having a band b^2 of felt around it, to be embraced by a two-part clamp b^3 , b^4 pivotally connected at b^5 , and held from rotation by an arm b^6 on one of the parts slotted at b^7 to embrace the rock shaft E. The separated ends of the clamp members are connected by a draw bar b^8 headed at b^9 and with a spring s^1 between it and the adjacent part of the member b^4 , the other end of the clamp bar passing loosely through the upturned part of the member b^3 , and having a locking cam b^0 mounted upon it to lock the clamp in operative position. By lifting the handle b^{11} of the cam in the direction of arrow o the clamp will be released, so that the ratchet can be readily rotated by hand when necessary. (Draper Co., Hopedale, Mass.)

BEAM LOCK FOR WHITIN LOOMS.

The object is to securely lock the journals of the warp beam against its fixed bearings and thus prevent all rocking motion or vibration of the warp beam as is caused by the strain on the warp during weaving.

The accompanying illustration is a side view of part of the end frame of a loom, showing the beam journal held against its fixed bearing on the end frame by a hooked clamp in solid lines, indicating at the same time in broken lines the position of the clamp when the journal is released.

A indicates one of the end frames of a loom, and O the rearward projecting horn, forming the temporary support of the journal 1 of the warp beam when the beam is placed in the loom. The journal 1 bears obliquely on the fixed bearing 2 in

the direction in which the strain on the journal is exerted. From the end frame A extends upward the lug 3, provided with the central slot 4. A bolster plate 5 is secured to the lug 3 by the bolts 6, extending through elongated holes in the lug 3, said bolster having a concave bearing on its upper end, on which bears the segmental cam 7 of the lever 8. In the centre of the cam 7, and near one side of the cam, are two concave seats connected by a plane surface. A round bar 11, which connects the hooked arms 12, is supported in the concave seat 9 when the journal is in the raised position, as shown in solid lines. As the seat

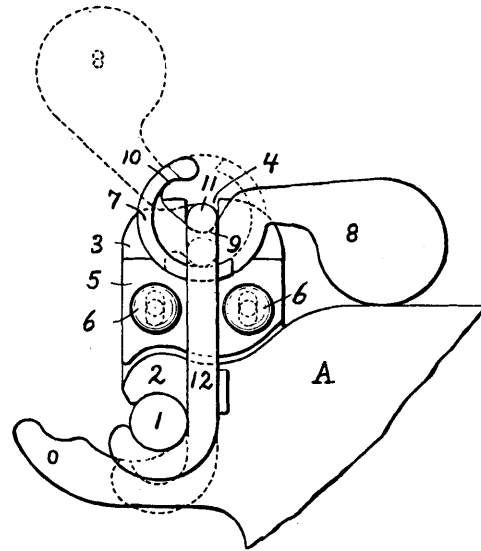

9 is in the centre of the cam, the hooked arms 12 are supported on what may be termed a "dead bearing," because no strain exerted by journal 1 on the hooked bars can change the position of the bearing.

When the warp beam is to be removed, the lever 8 is swung into the position indicated in broken lines, the hooked arms 12 being then supported by the bar 11, bearing on the concave seat 10. By loosening the bolt 6 the bolster 5 may be adjusted and the pressure exerted by the hooked arms on the journals 1 of the warp beam regulated. (Whitin Machine Works, Whitinsville, Mass.)

LET OFF FOR PILE FABRIC LOOMS.

One of the most important features for weaving tapestry carpets is the exact let off of the pile warp in order to produce as sharp a cut off of the change of colors in the fabric as possible, thus producing a more exact reproduction of the design in the fabric.

The illustration is a side elevation of the operative portions of this let off mechanism.

Examining this illustration, we find the pile warp 1 conducted from the rear side of the warp beam 2 in front of and over the roll 3 to the rear of and over the roll 4, over the sand roll 5, and around the roll 6, journaled in the short arms 7 of bell-crank levers 8.

Whenever a wire is inserted in the fabric, a greater length of the printed warp 1 is required in order to cover the wire and form the pile, and this extra length of warp is provided for and a uniform tension maintained by means of the roll 6, as journaled in the rocking-bell crank levers 8, the insertion of the wire causing the roll 6 to swing

forward and lift the weighted arms 9, which fall and carry the roll 6 back to take up any slack in the warp.

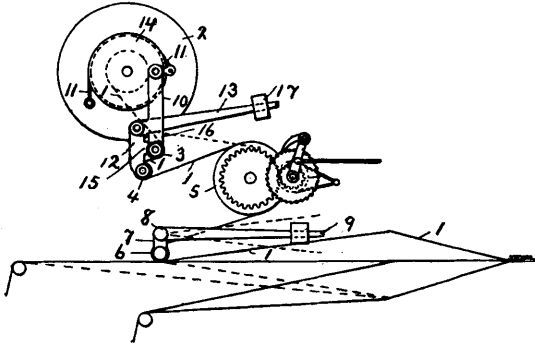

An indicator for the let off of the pile warp: For this purpose a graduated scale is applied to the sand roll 5 by drawing a series of lines on a strip of paper or thin cardboard and wrapping the same around the end of the sand roll beneath one or more spring clips, which serve to retain said cardboard in position and allow it to be exchanged for different graduated scales when desired and as directed by height of pile wires, or wires per inch used.

The bell crank levers 10, to which friction straps 11 are attached, are so arranged that the weight of the bell crank levers 12, with their weighted arms 13, will serve to draw the friction straps 11 closely against the friction wheels 14 and cause them to act as a brake upon the warp beam 2. As the warp is drawn forward by the intermittent rotation of the sand roll 5, a pulling strain is exerted upon the roll 4, holding the short projections 15 against the arms 16 of the bell crank levers 10, as shown in the illustration. The forward movement of the roll 4, when the projections 15 are in contact with the arms 16 of the bell crank levers 10, serves to rock the bell crank levers 10 and release the friction straps 11, thereby allowing the warp beam 2 to turn. As the rocking of the bell crank lever 12 must raise the weighted arms 13, the tension upon the yarn between the sand roll and warp beam can be adjusted by moving the weights 17 upon the arms 13, enabling that tension to be secured, which will cause the change of color to register accurately with the lines on the scale as marked on the thin strip of cardboard wrapped around the sand roll 5.

It will thus readily be seen that the weaver can regulate any variation in the let off as required by simply moving weight 17. (Crompton & Knowles Loom Works, Worcester, Mass.).

LET OFF FOR "DOUBLE SHED" LOOMS.

The mechanism relates to looms in which two banks of shuttles are used, the object being to provide for taking up the slack in the warp threads which extend during weaving in the plane of the fabric. The accompanying illustrations are side views of two forms of these tension devices.

Referring to Fig. 1, we find that there is a separate rocking arm for each whip roll 1 and 2, said support consisting of an angle lever 3, 4, each being pivoted to its respective pivot 5, 6. The arm 4 has on its outer end a stud or pin 7, adjustable in an elongated slot 8, and extending out from the side into a like slot 9 in the arm 3.

By this connection of arms 3 and 4, it will be seen that the tension on the set of warp threads

g, by the raising or lowering of the harness, will draw the arm 4, respectively carrying the roll 2, in the direction of arrow *a*. At the same time, by the pin and slot connection of the two arms, the arm 3 carrying the roll 1 will be moved in the direction of arrow *b* and put tension on the warp threads *h*. This motion of the two arms is simply reversed when the shed changes.

Referring to Fig. 2, which shows another arrangement of the whip roll supporting arms, we find used a separate arm or support for each end of the whip rolls 1 and 2, over which warp threads *i* and *j* respectively pass from the warp beam 10. Two arms 11 and 12 are pivotally connected at 13, with their free ends provided with open end slots 14 and 15 to receive the journals or ends 16 and 17 of the whip rolls 1 and 2. The opposite ends of the arms 11 and 12 are pivotally connected with the arms 18 and 19, and at the other ends of the arms 18 and 19 are pivotally attached to roll 20, which travels on a flange 21 on a stand 22. Spring 23, attached to a hook 24 on roll 20 and to a stationary point (not shown), acts to draw down the roll 20 and move whip rolls 1 and 2 toward each other.

Thus the tension on the set of warp threads *i* by the raising or lowering of the harness above or

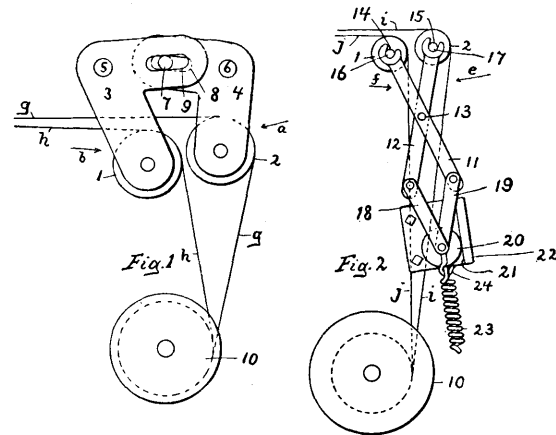

below the plane of the fabric will draw the whip roll 2 in the direction of the arrow *e*, and at the same time, through the shear joint connections, move the whip roll 1 in the direction of arrow *f* to put a tension on the warp threads *j*, extending in the plane of the fabric being woven, and *vice versa*, if the tension is on the set of warp threads *i*, the whip roll 1 will move away from the whip roll 2 and the tension put on the set of warp threads *i*. (Crompton & Knowles Loom Works, Worcester, Mass.)

LET OFF FOR NARROW WARE LOOMS.

This motion is used in connection with ribbon or other narrow ware looms, and belongs to that class of looms in which the delivery, *i. e.* let off of the warp thread from the spool is controlled by friction and operated by the take up of the thread.

The object of the mechanism is to provide a let off motion, simple in construction, and uniform and positive in its action, besides allowing exhausted spools to be easily substituted by full ones.

The working of the motion in connection with the loom and also the details of the arrangement are best explained by means of the accompanying illustrations, of which Fig. A is a vertical cross section,

showing a portion of a ribbon loom with a single warp thread spool, supplied with the new let off. Fig. B is a side elevation, partly in section, and on a larger scale than in Fig. A, showing a series of spools and their let off mechanisms more in detail.

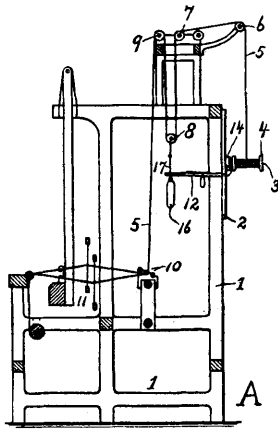

Referring to the illustrations, 1 indicates the frame of the loom, which is equipped with means for operating the lay, harness, and take up mechanisms in the usual manner. 2 is one of a group of bars supported on the frame 1 and carrying a series of fixed rods 3, extending outwardly to receive a corresponding series of warp spools 4. The warp threads 5 as

coming from the spools 4 are passed up over the pulleys 6 and 7, then down under the suspended pulley 8, and back again over the pulley 9 from which point they are passed under whip rolls 10 to the harnesses 11. Friction is put on the spools 4 by means of levers 12, centred at 13, pressing with its short end against friction pulleys 14, to which the spools are secured by means of screws 15, the other ends of said levers 12 being weighted in order to produce the required friction. The suspended pulley 8 is held down by a weight 16, which is connected to it by means of a wire 17 passing through the forked end of the lever 12. The friction on the spool 4 is sufficient to cause the pulley 8 and its weight 16 to rise when the take up motion of the loom is pulling the warp threads forward. As the weight 16 continues to rise, it finally comes in contact with the lever 12 and raises it slightly, which action causes a decrease in the friction on the spool 4 and consequently more warp is unwound. With this unwinding of the warp from the spool, the weight 16 falls out of contact with the lever 12 and thus the unwinding is stopped. The weight again starts upward and when it comes again in contact with the lever 12, the same unwinding will result, and in this manner

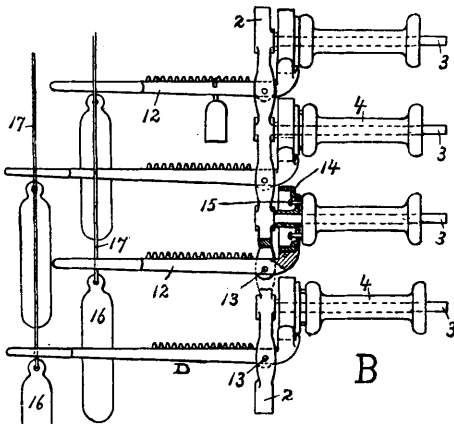

a uniform and even let off of the warp is automatically obtained. The spools are not placed directly over each other in the frame, in order to avoid any

interference with the freedom of the weights, also the levers 12 are made alternately long and short for the same purpose. (William W. Uhlinger, Paterson, N. J.)

TAKE UP MECHANISMS.

TAKE UP MOTION FOR WHITIN LOOMS.

Thin places are frequently caused in the cloth, during weaving, due to the fact that the take up motion of the loom continues in operation for a brief space of time after the filling fork has detected the absence of filling in the shed. The object of the new mechanism is to arrest automatically the cloth take up as soon as the absence of filling in the shed is detected by the filling fork.

In order to better explain the mechanism, the accompanying two diagrams are given, showing the principal working parts of this take up in relation to each other, and their positions with reference to the framing of the loom.

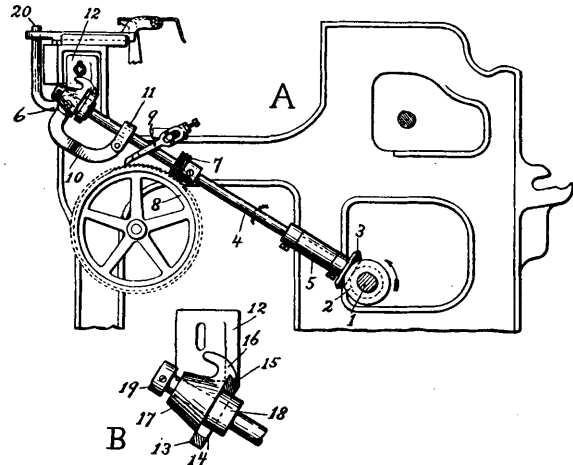

Diagram A is an end view of the loom showing the parts of the mechanism in their correct positions while the loom is running. Diagram B is a side view, partly in section, of the latch head by which the take up mechanism is held up out of contact with the ratchet wheel of the take up motion.

The motion consists essentially in an oblique shaft driven at one end from the cam shaft. Near the centre of its length a worm is fastened to it, which works into the ratchet wheel, and this in turn drives the sand roll. The other end of the shaft is supported by a bracket which is attached to the rock shaft, so that when the filling breaks and the rock shaft is partly rotated, the oblique shaft is raised, causing the worm to disengage the ratchet wheel, and so arrest the take up of the cloth.

Referring to diagram A, 1 is the cam shaft, to the end of which is secured the bevel gear 2. Meshing into 2 is the gear 3 fixed on the end of the oblique shaft 4. This end of the oblique shaft is held in position by the sleeve 5, the bracket which holds it being journaled on the cam shaft. The oblique shaft 4 extends from the cam shaft 1 toward the rock shaft 6 and has secured to it the worm 7, placed so as to engage with the ratchet gear 8, with which the pawl 9 engages to hold the ratchet gear in the advanced position. To the end of the rock shaft 6 is secured the bracket 10, the opposite end of which is jointed to the collar 11, around the shaft 4, but loose on the same. On the end framing at the breast beam

is secured the bracket 12, the arm 13 of which is provided with the elongated opening 14 (see diagram B). The edge 15 is beveled so as to engage with the hook 16 of the latch head 17, the stud 18 which is attached to it being provided with flattened sides and extends through the elongated opening 14 in the arm 13. The shaft 4 extends through the latch head 17 with a loose sliding fit. The collar 19 is secured to the end of the shaft 4.

When the parts are in the normally operative positions (shown in diagram A) and the loom is running, the worm 7 is in engagement with the ratchet gear 8, which controls the rotation of the sand roll and consequently the take up of the cloth. The worm securely locks the ratchet gear, so that it cannot be moved by hand, as is the case when the ratchet gear 8 is operated by a reciprocating pawl mechanism in which the take up mechanism may be and at times is operated by hand to secure a surreptitious gain of cloth. When now a shuttle fails to lay the required pick, the filling fork is carried backward by the snake head and by means of the regular levers, shifts the belt from the fast to the loose pulley. At the same time that the fork goes backward it pushes the arm 20 out, and this arm being attached to the rock shaft 6, causes it to partly rotate. The bracket 10, rocking with the rock shaft, raises the shaft 4 and disengages the worm 7 from the ratchet gear 8, which is, however, held in the advanced position by the pawl 9. The hook 16 on the latch head 17, having been brought higher than the edge 15, slides down over it, thus securing the shaft in the raised position, with the worm 7 out of contact with the ratchet gear 8.

By this arrangement the take up mechanism is disconnected at the same time with the release of the spring shipper, and the take up of the cloth or the warp instantly arrested. The weaving of thin places in the cloth is thus avoided and the laborious back winding of the warp and cloth by the weaver unnecessary. On releasing the latch head 17, the worm 7 engages with the ratchet gear 8 and continues to take up the cloth as it is woven. (Whitins Machine Works, Whitinsville, Mass.)

TAKE UP MECHANISM FOR DRAPER LOOMS.

In this mechanism two filling forks are employed (one on each side of the loom), the one acting to effect the stoppage of the loom on failure of filling, the other co-operating only with the take up pawl to prevent its operation and thereby obviate thin places in the cloth.

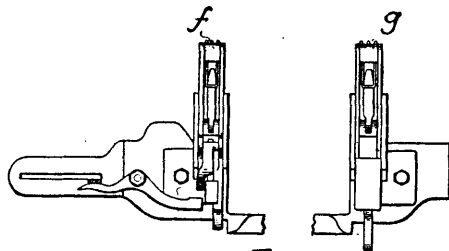

Fig. 1

Fig. 1 is a top view of the two filling forks, one at each end of the loom, and Fig. 2 is a detail of a portion of the take up mechanism.

In co-operation with the take up mechanism two pawls d and e are shown to operate successively, the pawl e being fulcrumed on a stud e^1 and longitudinally slotted to straddle the shorter pawl d , which is also slotted as at d^1 , to slide on the stud e^1 when the pawl e is disengaged.

The pawl carrier a is bent and extended forward

as at a^1 and at its outer end an upright short arm a^4 is adjustably secured to it by a bolt a^5 .

The pawl e has at its fulcrumed end a depending ear e^2 , on which is pivoted a dog e^3 , having a cam surface e^4 on its lower edge adapted to rest on and be actuated by a pin d^2 on an arm d^3 . This arm d^3 is provided with a cam rib d^4 , and the dog e^3 has on its inner face a lateral shoulder e^5 .

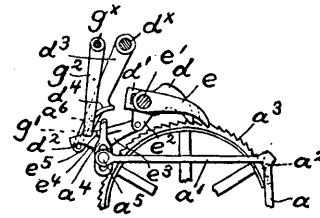

Fig. 2

with the ratchet wheel a^3 , and at the same time the arm g^2 engages the pin a^6 and through the arm a^4 disengages the actuating pawl a^2 . Thus the action of the take up is interrupted, and at the same time the disengagement of the pawl e permits the take up to let back as far as allowed by the slotted pawl d , preventing a thin place in the cloth, while the fork f detects on the return shot of the shuttle and thus stops the common loom, or effects a change of filling carriers in connection with Northrop looms.

When the fork f operates, it moves the rock shaft dx , and the arm d^3 thereon is swung inward, the pin d^2 acting on the cam edge e^4 of the dog, lifts the pin until the shoulder e^5 is above an offset g^1 on arm g^2 , and as the arm d^3 swings inward, the cam rib d^4 engages the projection a^6 of the arm a^4 and disengages the actuating pawl a^2 , so that the take up action is stopped at once, thus preventing a thin place in the cloth. (Draper Co., Hopedale, Mass.)

TAKE UP MECHANISM FOR C. & K. LOOMS.

The object is to provide means for releasing the winding up roll from contact with the take up roll, when removing said winding up roll from the loom; or to release one end only of the winding up roll to adjust the edge of the cloth at that end.

The accompanying illustration is a front view of the take up mechanism, having this device applied.

The take up roll 1 is supported at its ends in bearings on stands 2 and 3, attached to the breast beam 4 and loom side 5. The winding up roll 6 extends below the take up roll 1 and has a journal $6'$ at each end thereof, which extends into the fixed vertical guideways 7 on the stands 2 and 3, said guideways 7 being open at their lower front edge to allow the removal of the journals $6'$ and the taking out of the winding up roll 6, as supported by the vertically moving supports 8, one at each end of the winding up roll, the upper end of each support being recessed or grooved to receive the journals $6'$ on the ends of the winding up roll 6.

The lower end of each support 8 is pivotally connected to one arm of angle levers 9 and $9'$. The angle lever 9 is fast on the shaft 10, and the angle lever $9'$ loose thereon, said shaft 10 being loosely mounted at each end in stands 11, secured to the cross girth 12 of the loom. The other arm of each angle lever 9 and $9'$ is connected to a rod 13, provided with an adjustable spring 14, and loosely mounted at its inner end in a stand 15, attached to the back girth 16 of the loom to have a sliding motion therein. The springs 14 bear at one end against the stand 15 and at the other end against an adjusting collar 17, se-

cured on the rod 13 by a set screw, and act to yieldingly hold the winding up roll 6 in its upper position

the number of picks introduced per inch in the cloth, by simply changing one of the gears, the number of teeth in this change gear representing the desired number of picks to the inch put in the cloth.

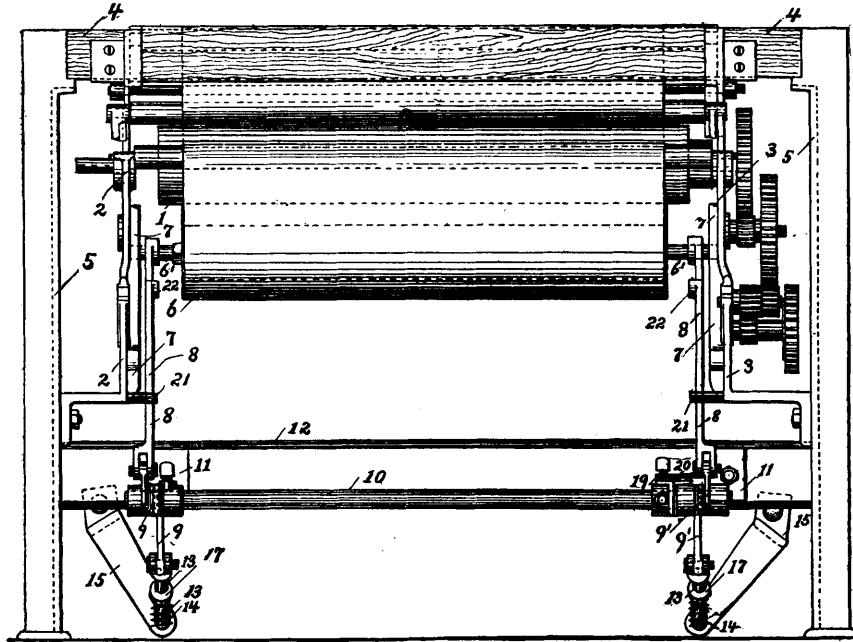

Of the accompanying illustrations, Fig. 1 is a side view of sufficient portions of a loom to illustrate this take up, and Fig. 2 is a view of the same, partly in end elevation and partly in section.

A description of the construction and operation of this take up is best given by quoting numerals of reference accompanying the illustrations, and of which 1 represents part of the loom frame, 2 part of the lay, which carries a pin 3, engaging with a slotted lever 4, hung to a pin 5, which is adjustable longitudinally in a slotted lug 6 fast to frame 1. Lever 4 has a slot 7, which engages the pin 3, and a slot 8 for the reception of an adjustable pin 9, which carries a pawl 10, which in turn en-

gages with the teeth of a ratchet wheel 11, the latter being mounted so as to be free to turn upon a stud 12, and pressed against the take up roll 1 through the angle levers 9 and 9', and vertically moving support 8. The shaft 10 has fast upon it at the right hand end a foot treadle 19, projecting toward the front of the loom. Beside the treadle 19 and integral with the angle lever 9', which is loosely mounted on shaft 10, is a second foot treadle 20.

gages with the teeth of a ratchet wheel 11, the latter being mounted so as to be free to turn upon a stud 12,

When the treadle 19 is pressed down by the foot of the attendant, it will rock the shaft 10 and move down the front end of the angle lever 9 at the left hand end of the loom, and with it the support 8 of the winding up roll 6 at that end of the loom. When the treadle lever 20, integral with the angle lever 9', loose on the shaft 10, is moved down, the angle lever 9' will also be moved down with it and the support 8 at the right hand end of the winding up roll 6, to release said end from the take up roll 1. If the two treadles 19 and 20 are moved down together, angle levers 9 and 9' will be operated and both ends of the winding up roll 6 will be lowered simultaneously.

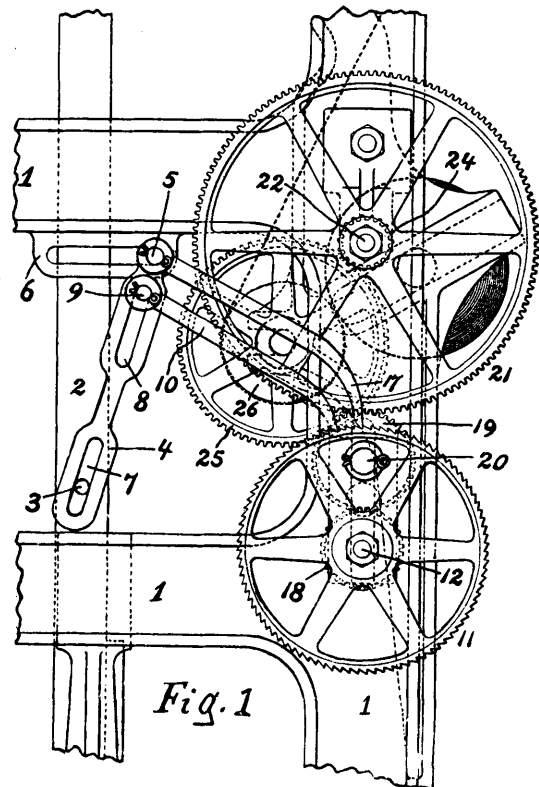

The stands 2 and 3 are each provided with a projection 21, against which the support 8 will rest when in its lowest position and with the journals 6' of the winding up roll 6 at the opening in the guideways 7, preparatory to the removing of the winding up roll 6 from the loom.

When the supports 8 are in their lowest position, they are retained there against the pressure of the springs 14 by the lugs 22 thereon engaging with the projections 21. When the foot of the attendant depresses the levers 19 and 20, and moves back the winding up roll 6, so that its journals 6' will enter the vertical portion of the guideway 7, the lugs 22 will be disengaged from the projections 21 and the springs 14 through intermediate connections will act to raise the winding up roll 6 into yielding contact with the take up roll 1 and hold it there. (Crompton & Knowles Loom Works, Worcester, Mass.)

ANDERSON'S TAKE UP MECHANISM.

The object aimed at in this take up is its simplicity of construction and operation, the fixer being able to change the action of this take up, *i. e.* change

secured to and projecting from a slide 13 on the side frame 1 of the loom. Vertical adjustment of this

slide 13 on the loom frame is effected by providing said frame with a vertical slot 14 for the reception

AUTOMATIC FILLING CHANGING MECHANISMS.

A FILLING CHANGING DEVICE FOR NOR-THROP LOOMS.

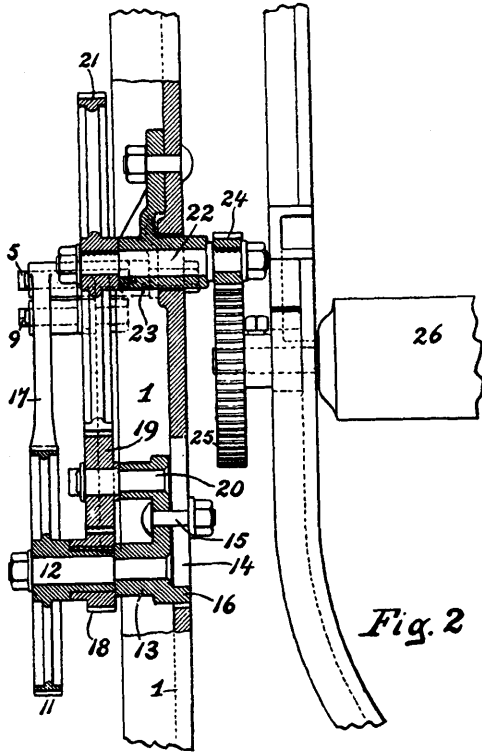

Fig. 2

of the bolt 15, whereby the slide is secured to the frame, a lug 16 on the slide also entering said slot, as shown in Fig. 2, so as to insure the proper guidance of the slide in its vertical movement. Hung to the fulcrum pin 5 of the lever 4 is a detent 17, which engages with the teeth of the ratchet 11 and prevents back movement of the same. Secured to the hub of the ratchet wheel 11 is a pinion 18, and meshing with the latter is another pinion 19, which is free to turn upon a stud 20, secured to, and projecting from, the slide 13, said pinion 19 meshing with a spur wheel 21, which is secured to a shaft 22 free to turn in a hanger 23, secured to the frame 1, as shown in Fig. 2, said shaft 22 also having a spur pinion 24, which meshes with a spur wheel 25 on the shaft of the take up roll 26. The spur wheel 21 constitutes the change wheel of the gearing and has as many teeth as the desired number of picks per inch in the fabric to be woven, see heavy dotted line 26 indicating direction of the run of the woven cloth from breast beam, to take up roll 26 to cloth beam 27. The ratio of the spur wheel 25 and the pinion 24, being fixed and the number of teeth in the ratchet wheel being also known, all that remains to be determined, in order to permit the use of a change gear as described, is the respective relation of the circumference of the take up roll 26 to the number of teeth in the pinion 18, the pinion 19 being a negligible quantity.

Assuming that C represents the circumference of the take up roll, P the number of teeth in the pinion 18, R W the number of teeth in the ratchet wheel, and R the ratio between the wheels 24 and 25, the equation is as follows: $\frac{C \cdot P}{R \cdot W} = R$. (The D. A. Tompkins Co., Charlotte, N. C.)

This device has for its object to provide means in the regular filling changing mechanism of the Northrop loom, whereby the filling will not be changed suddenly upon the action of the filling feeler, thus producing a more uniform action, at the same time relieving the parts from sudden strain.

Fig. 1 is a sectional side elevation of the filling fork and the parts for controlling the operation of the filling supplying mechanism, showing said parts in normal position before the feeler has felt the filling in the shuttle. Fig. 2 is a perspective view of the sliding latch support and the guide therefor.

The device is operated upon by the regular filling feeler of the loom. A stop b^x is secured to the stand B, as fastened to the breast beam of the loom, by a bolt extended through the slot b^6 in a lateral extension b^4 . The stand B is also provided with upright walls b^1, b^2 , to form a guideway for the filling fork slide m , the bottom of the guideway being longitudinally slotted as at b^3 to permit the vibration of the filling hammer W. The extension b^4 is separated by a guideway b^5 , in which is longitudinally movable a sliding bar c , having an upturned ear c^1 , and being cut away as at c^2 . The slide bar c has fulcrumed on its ear c^1 , as at c^4 , a latch carrier c^5 , provided with a depending foot c^6 , which rests on the arm of the filling feeler (not shown) when the latter is in normal position. To the inner end of the latch carrier c^5 , is pivoted at g a depending latch cx , which rests against the enlarged end c^3 of the slide bar c , the lower end of the latch cx , when in normal position, extending into the path of the dog w of the filling hammer W, so that when said hammer moves forward it will engage the latch and move it and the slide bar c to the right, in Fig. 1, the outer end of said bar engaging an upturned arm d^3 , fast on rock shaft d^1 , and thereby effect the filling change.

In order to prevent any lifting tendency of the slide bar c , it is provided with a lateral lug c^9 , having a beveled upper face to extend under an upturned and overhanging projection b^9 on the wall b^1 , and the extension b^4 has an overlapping detent b^{10} , secured to it and extended over the outer end of the slide

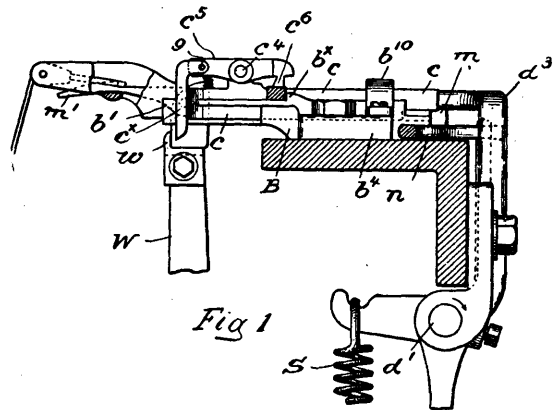

Fig 1

bar c , so that the latter when moved outwardly by engagement of the filling hammer and the latch will move properly in its guideway b^5 . The return of the slide bar to normal position is effected by the action

of the spring S through the shaft d^1 and arm d^3 , inward movement of the slide being limited by the engagement of the lug c^9 and stop b^9 .

When the filling in the shuttle is sufficient in volume to swing the feeler upon its fulcrum, the extremity of the feeler arm will be swung inward or toward the lay, and thereby drawn from beneath the foot c^8 of the latch carrier, whereupon the spring S will lift the inner end of the carrier, raising the latch from the path of engagement of the dog w of the filling hammer before the critical point in the stroke of the latter is reached, and no movement of the slide c will be effected. When the latch is lifted, the foot c^8 descends between the stop b^2 and the arm of the filling feeler, and so prevents return of said arm against the stop, and consequently the return of the feeler to normal position is prevented until the foot c^8 is lifted or withdrawn from in front of the arm of the filling feeler.

Should the filling break, or be accidentally exhausted, the outward movement of the filling hammer will operate through the hook m^1 and the tail

of the fork to move the slide m out and into engagement with the end of the knock off lever, moving the same against a spring, thus releasing the shipper handle from its holding notch and stop the loom. The end of the knock off lever n is notched, to embrace an

upturned arm d^4 , loosely mounted on the rock shaft d^1 and having a downturned end d^5 to effect disengagement of the take up pawl and ratchet when the loom is stopped. (Draper Co., Hopedale, Mass.)

RETARDING DEVICE FOR THE FILLING FEEDER IN NORTHROP LOOMS.

The object of this device is to provide means for retarding the movement of the feeder before the filling carrier reaches its fixed stop, thus obviating any shock to the filling carrier.

Fig. 1 is a transverse section of a portion of a loom and its filling supplying mechanism. Fig. 2 is an enlarged perspective (compared to Fig. 1) of the retarding device and Fig. 3 is another form of the same.

The guard c , as extending around the filling feeder plate a , is cut away at its lower end, between which and the "stop" for the filling carrier to be next operated upon, is interposed the new retarding device, consisting of a flat plate h having a hub h^1 at one end, and reduced in diameter at the other end, forming a stud h^2 , which is extended through the stand a^1 . A spring (not shown) coiled around the stud h^2 tends to lift the plate h into the path of the filling carriers.

When the transferrer descends to change the filling carrier the plate h yields, hence serves as a support and guide for the filling carrier.

As soon as the transferrer is retracted the plate h is moved up by its spring, previously referred to, into engagement with the next filling carrier, and as the feeder moves forward the plate is depressed gradually into the position shown in Fig. 1, the resistance thus made by the plate acting as a retarding

device, allowing the filling carrier to come gradually against the stop (seen at the left of the filling car-

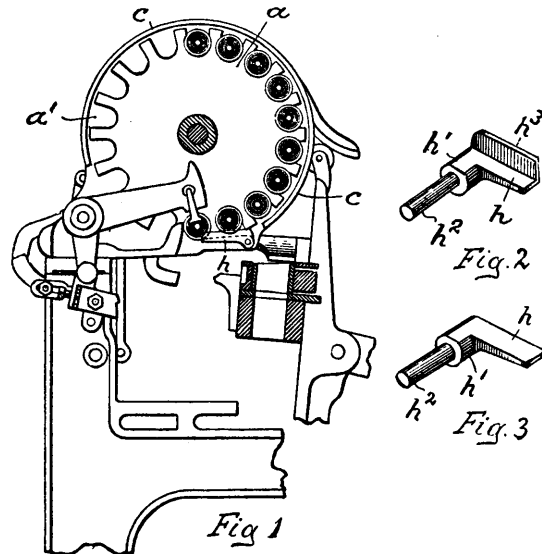

rier to be operated upon next, and against which the latter rests), instead of with a quick sudden jar.

When cops are used the plate h is provided with a flange h^3 as shown in Fig. 2, to fit in between the yarn and the head of the skewer; but when bobbins are used the plate is made merely flat as shown in Fig. 3. (Draper Co., Hopedale, Mass.)

AN IMPROVED "STOP" FOR FILLING CARRIERS FOR NORTHROP LOOMS.

In the ordinary construction of the filling supplying mechanism a smooth stop is employed for guiding the filling carrier, when to be transferred, the new device having for its object the production of means for engaging and positively guiding the filling carrier into its proper position relatively to the shuttle when transferred from the feeder.

Fig. 1 is an enlarged perspective view of the guide detached, showing the means for guiding and positively engaging the filling carrier, and Fig. 2 is a part plan view of the head of a filling carrier in engagement with the guide shown in section.

This guide is L-shaped, its foot 1 being held in place by bolts. The front end of the foot is upturned at 2 to form the stop proper, which projects in the path of and engages the head of the filling carrier next to be transferred, the face of the stop being convex from top to bottom to conform to the movement of the filling carrier during transfer. A series

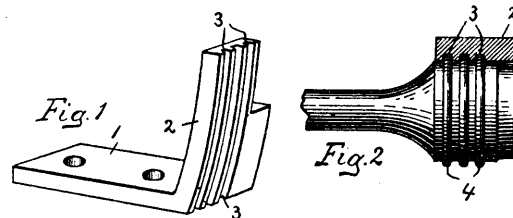

of longitudinal grooves 3 are formed in the convex face to receive the projections 4 on the head of the filling carrier, so that during transfer the stop positively engages and guides the filling carrier until it

enters the shuttle, effectually preventing any longitudinal displacement of the filling carrier or any twisting from its proper position as it enters the shuttle. (Draper Co., Hopedale, Mass.)

SHUTTLE SUPPLYING MECHANISM FOR C. & K. AUTOMATIC LOOMS.

This mechanism has for its object to provide means by which a number of shuttles, one after the other, may be supplied automatically to the shuttle feeder, doing away with the placing of a fresh shuttle on the feeder any time a change of shuttles had occurred.

Fig. 1 is a front view of a part of a loom, showing the parts of the shuttle changing mechanism. Fig. 2 is an end view of the reel showing the manner of holding the shuttles.

Extending out from the breast beam is a stud 15, on which is loosely mounted the hub 16' of the reel 16, said reel being provided with outwardly-extended fingers 16", forming recesses to receive the shuttles 17. The shuttles 17 are held in the recesses by means of spring actuated fingers 18 pivoted on the studs 19, springs 20 keeping said fingers against the shuttles.

Fast on the outer end of the stud 15 is a stationary circular guide 22, and a corresponding guide 23 is secured to the end of the breast beam. These guides are grooved on their inner surfaces to receive the points of the shuttles and hold the same in proper position as the reel 16 revolves to supply a new shuttle to the feeder plate.

A lever 29 is centrally pivoted on a shaft 30 mounted in a stand 11 as secured to the loom side.

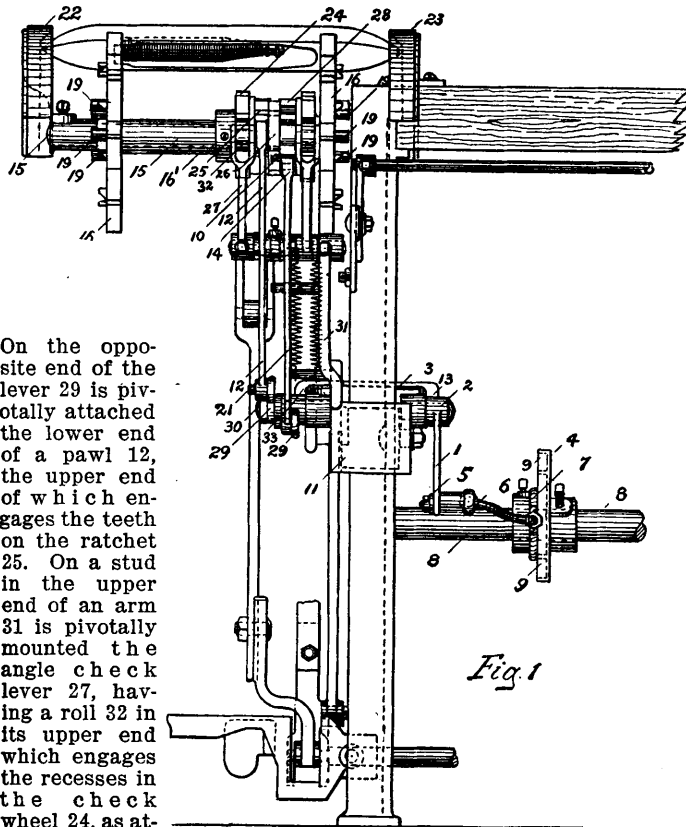

On the opposite end of the lever 29 is pivotally attached the lower end of a pawl 12, the upper end of which engages the teeth on the ratchet 25. On a stud in the upper end of an arm 31 is pivotally mounted the angle check lever 27, having a roll 32 in its upper end which engages the recesses in the check wheel 24, as attached to the ratchet 25, to hold said ratchet in position after each partial revolution.

A lever 33 is loosely mounted on the shaft 30, and to its outer end is pivoted the lower end of the pawl

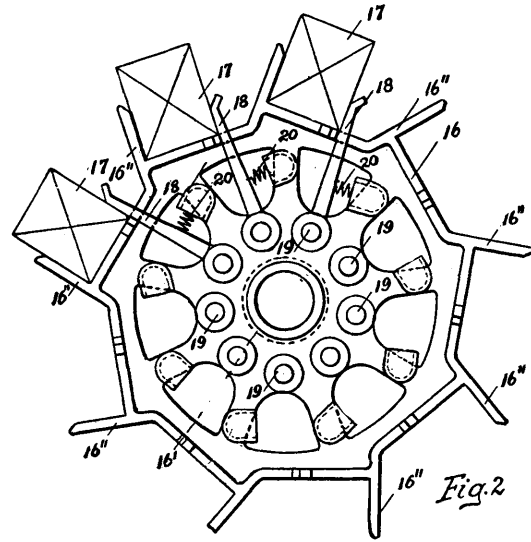

21, the upper end 14 of which is adapted to engage the ratchet teeth of the ratchet 28 and turn the reel.

The inner end 13 of the lever 33 is connected by a bar 3 with the hub 2 of the lever 1, said hub 2 being loosely mounted on the shaft 30. The free end of the lever 1 is slotted and pivotally attached by a bolt 5 to the outer end of the rod 6, the inner end of which is provided with a forked end 7, carrying a pin which travels in a cam groove 9 in the cam 4, fast on the bottom shaft 8. The revolution of the cam 4 through the pin previously referred to, rod 6, lever 1, bar 3 and lever 33, communicates a regular up and down motion to the pawl 21; but said pawl, by reason of a pin 10 thereon riding on the pawl shield 26, forming a part of the ratchet 24, cannot engage and turn its ratchet 25 and the reel 16 until the pawl shield 26 is moved out of the way of the lug or pin 10.

Whenever the change shuttle mechanism operates by reason of the failure of the filling, the pawl 12 is operated through lever 29 to give one turn to the ratchet wheel 24. The movement of the ratchet wheel 24 also moves the pawl shield 26 and allows the pawl 21 to engage and move its ratchet wheel 25, fast on the hub 16' of the reel 16, and communicate a partial rotation to the reel 16 and deposit a shuttle on the shuttle feeder plate immediately after the shuttle feeder has returned to its normal position from carrying a shuttle into position to be thrown through the shed. (Crompton & Knowles Loom Works, Worcester, Mass.)

SUPPLEMENTAL MECHANISM TO THE C. & K. AUTOMATIC LOOMS.

The object is to provide means by which the movement of the shipper handle, to stop the loom, will automatically throw the filling changing mechanism out of operation, the same remaining out of operation

upon the return movement of the shipper handle to start the loom, until the weaver puts said filling changing mechanism again into operation, thus permitting the running of the loom with or without its filling supplying mechanism.

The illustration is a top plan view of the filling fork slide and its co-operating parts of the filling supplying mechanism, the shipper lever being in operative position.

On the filling fork slide is pivoted the usual actuating lever 1 of the filling supplying mechanism, and between this lever 1 and the shipper handle 2 is a lever 3, which forms the connection whereby the filling supplying mechanism is thrown out of opera-

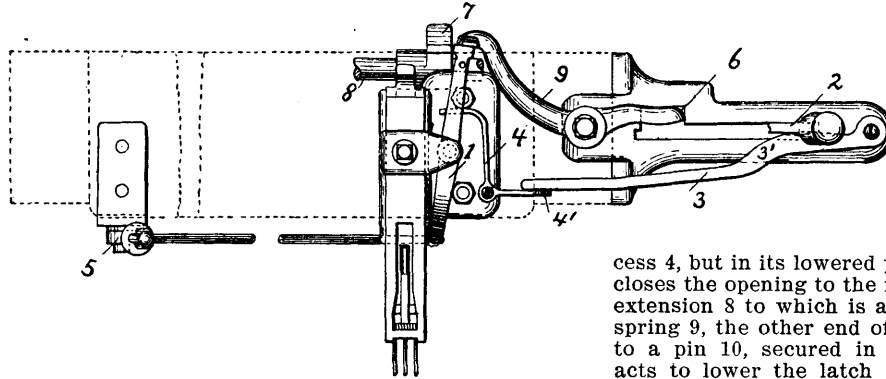

tion. This lever 3 is provided with a cam surface 3', adapted to be engaged by the shipper handle. The free end of the lever 3 engages the arm 4' of an angle lever 4, the other arm of said angle lever being bent upward to engage the actuating lever 1 of the filling supplying mechanism.

When the shipper lever 2 is moved by the weaver out of the notch 6, it engages the cam surface 3' of the lever 3 and moves outwardly the free end of said lever, which in turn moves the angle lever 4 and causes the actuating lever 1 to move out of engagement with the arm 7 on the shaft 8, which operates the filling changing mechanism. When the shipper lever 2 is returned by the weaver to its position in the notch 6 to start the loom, the actuating lever 1 will still remain out of engagement with arm 7, so the filling changing mechanism cannot operate, but said lever 1 will remain in engagement with the knock off arm 9 and stop the loom in case of filling failure in the running shuttle.

When it is again desired to throw the filling supplying mechanism into operative position, the weaver by operating the lever 5 brings the actuating lever 1 into position to engage with the arm 7 of the filling supplying mechanism. (Crompton & Knowles Loom Works, Worcester, Mass.)

FILLING DETECTING MECHANISM FOR C. & K. AUTOMATIC LOOMS.

The object of the mechanism is to provide a feeler device for the bobbin in the shuttle, so that a new shuttle containing a full bobbin may replace the one in the loom just before all of the filling runs entirely off the bobbin, in order to prevent any possibility of missed picks in the cloth.

The mechanism consists essentially of a specially constructed shuttle and a projecting bar on the loom, for detecting the near absence of filling on the bobbin at the proper time so that the replenishing mechanism may be operated to replace the about exhausted bobbin in time with a full one. The details

of the construction of the shuttle, showing the mechanism in the two principal positions, are given in the accompanying illustrations, of which Fig. A is a vertical cross section of the part concerned in the shuttle, showing the mechanism in the position when a full bobbin is in the shuttle, and Fig. B is the same cross section of the shuttle, showing the mechanism in the position which it occupies when the bobbin is nearly empty and ready to be replaced.

Referring to the illustrations, 1 indicates the body of one end of a shuttle, 2 a spindle for holding the bobbin or cop, pivotally mounted at one end in the shuttle, and 3 is the bottom portion of a cop as placed on the spindle 2. A recess 4 is made in the outside of the shuttle near its rear end, and at the bottom of the shuttle. This recess 4 extends in the shuttle body upwardly in the form of a narrow slot 5, within which is free to move a latch 6, pivoted on a pin 7. The latch 6 in its raised position, as shown in Fig. A, leaves a free opening in the recess 4, but in its lowered position, as shown in Fig. B, closes the opening to the recess 4. The latch 6 has an extension 8 to which is attached one end of a coiled spring 9, the other end of said spring being attached to a pin 10, secured in the shuttle. The spring 9 acts to lower the latch 6 when it is released from engagement with the extension 11 on the filling feeler 12, which is pivoted on the pin 13. The curved flattened end 14 of the feeler 12 bears on the bobbin or cop 3 and is held in engagement with it by a spring 15 which is attached at one end to the feeler 12 and coiled around and fastened at its other end to the pivot pin 13 of the feeler 12.

When the bobbin or cop 3 is full, as shown in Fig. A, the feeler 12 is held outwardly, and the extension 11 is caused to engage the extension 8 on the latch 6 and hold the latch in its raised position against the action of the spring 9. As the filling on the cop 3 is

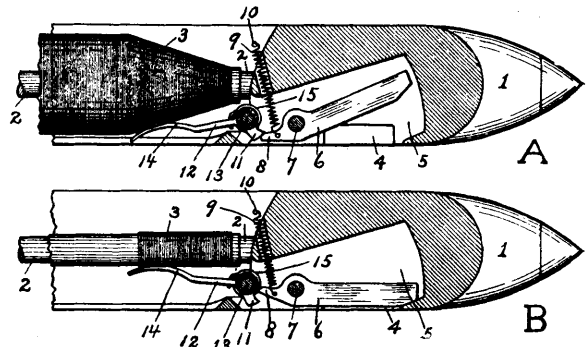

gradually exhausted, the feeler 12, which is operated by the spring 15, moves on its pivotal support 13 until the filling is nearly exhausted, when then the extension 11 passes by the extension 8 on the latch 6 and allows the spring 9 to instantly lower the latch, as shown in Fig. B.

A projection from the loom, which enters the recess 4 in the shuttle when the lay comes up to the fell of the cloth, is suitably connected to the filling fork mechanism which operates the replenishing mechanism in the usual manner, and when the latch 6 is held up by a sufficiently large cop, as explained, the projection will enter the recess 4 properly, and no

transfer of bobbin, cop or shuttle, as the case may be, will take place, but as soon as the cop or bobbin becomes small enough through weaving, to allow the latch to fall over the recess 4, the projection is prevented from entering said recess 4, and consequently acts upon the filling fork, which, through proper mechanism, replaces the cop, bobbin or shuttle, as the case may be.

The time of the disengagement of the extension 11 on the feeler 12 from the extension 8 on the latch 6, to allow the latch 6 to be lowered, is regulated by the amount of filling to be left on the cop or bobbin 3 before it is replaced by a full one. (Crompton & Knowles Loom Works, Worcester, Mass.)

STOP MOTIONS.

ELECTRIC WARP STOP MOTION,

With Signal for Locating Broken End or Ends at a Glance.

This stop motion, built by Textile Appliances, Ltd., Providence, R. I., is most simple in its construction, operation and application to any make of loom, as will be readily understood from the accompanying illustrations, and is especially interesting on account of the distinct novelty of the method by which such simplicity is secured. In Fig. 1 the actuating mechanism is shown in side elevation, with parts in section, in the position occupied when the loom is running, with no thread broken; while Fig. 2 shows the same mechanism, in perspective view, with parts in section, in the position when the loom is stopped, on account of a broken thread.

The operation of the stop motion is as follows: A lease *a* is taken in the warp, and between every two threads a straight spring, steel wire *b* is engaged, as shown at Fig. 1, in such a way that it cannot pass to the larger lease rod *c*, which is provided with a metal slip pointing towards the

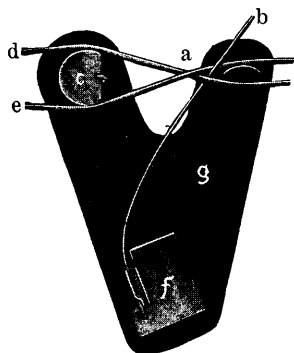

Fig. 1.

other lease rod, so long as the two warp threads *d* and *e* are unbroken. If, however, either of these threads breaks, the wire *b* springs back against the metal slip in the lease rod *c*, Fig. 2, and thus closes an electric circuit, carrying a weak and sparkless current like that used for the telephone, operates a simple mechanism connected with the belt shipper, and stops the loom. In fact, the action is virtually a mechanical one, the electrical arrangements being of insufficient power even to indicate the nature of the action.

The spring wires *b* are set in combs, usually about an inch long, which are carried in the comb clamp *f* below. These inch segments accommodate sets up to any number within the requirements of weaving practice. For fine goods, and where frequent change of sley is required, a shorter segment is used so as to provide for variation in the latter respect within the wider limits necessary. The tension of the wires *b*, on the lease *a*, is under complete control, and can be regulated to entirely avoid abrasion of the yarn; it is governed by the angle at which the comb clamp *f* is held relatively to the contact rod *c*. This comb clamp *f* can be readily adjusted by changing

its position in the end plates *g* relatively to the contact rod, suitable holes being provided in the latter

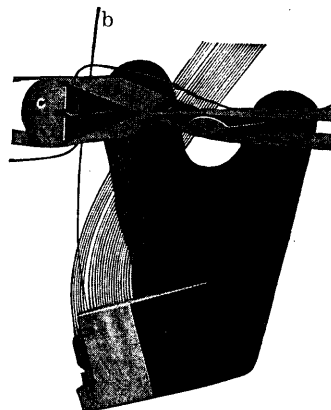

Fig. 2.

for this purpose. Two end plates *g* are used, one on each side of the warp; only one can be shown in the illustrations, the other being a duplicate of it.

This stop motion occupies no more space than an ordinary lease, because the stopping device is contained between the two lease rods. The warp can be drawn into the combs, either by hand or by a drawing in machine, before it comes to the loom, or the combs can be placed in position after the warp is hung in the loom. All that is necessary to hold the two lease rods and the bar *f* in position in the loom, is the ordinary pair of leather straps, connecting them to the whip roll. The lease rods are thus not fixed to the loom side, but are free to take their proper positions, and allow the natural movement of the warp, so that the cover of the cloth is unaffected. A pair of flexible wires, passed under screws at the ends of the contact rod *c* and comb clamp *f*, suffice to convey the small current.

It remains to describe the small electromechanical motion which knocks off the handle of the loom when the circuit is closed upon the breakage of a thread. It consists of a novel arrangement by which an exceedingly small current is made available to bring about the required action. The principle is such that the actual force required to knock the handle off, which is sometimes considerable, is supplied entirely by a moving part of the loom itself, and not by the electrical mechanism, which only acts to cause a locking effect, which brings this outside force into play. The novelty of the arrangement lies in the method of producing this locking effect so as to cause the force supplied by the loom to be transmitted through the device to the starting handle with the exercise of a very small magnetic force. The parts, with the exception of a lever, through which the motion is derived from any moving part of the loom, and a projecting moving part, which acts upon the setting-on handle, are all enclosed in a dust-tight casting, made with a circular slotted flange, by which it can be very readily clamped by two bolts upon the loom side. Simple arrangements are provided to convey to it motion from any moving part of the loom, which is generally found conveniently on the reciprocating sword. The mechanical and electrical details of this device have been so thoroughly worked out, that while it can be actuated by so small a current, it is practically proof against wear. Sufficient current to operate the mechanism of one loom is easily derived from a single dry cell, sealed in a boxescrewed below the loom, whereas in a complete installation the current is derived from a small dynamo.

The spring wire *b*, released by means of a broken warp thread, besides stopping the loom, as before described, at the same time provides for a clear signal to the weaver (see Fig. 2) where the broken warp thread is located, thus making mending quick work, resulting in turn in an increased production per loom, an item of the greatest importance to manufacturers. (Textile Appliances, Ltd., Providence, R. I.)

WARP STOP MOTION FOR C. & K. LOOMS.

This construction is an improvement to the one described on pages 63 and 64 of Part 2 of this work, and has for its object to modify the construction of the detectors, and to combine therewith a transverse guide bar having its upper edge toothed; an additional transverse guide bar with a plain upper edge being arranged vertically adjustable in connection with the former.

Fig. 1 is a sectional view of this stop motion mechanism, and Fig. 2 a front view of the stationary and the adjustable transverse bars, the left hand section showing the

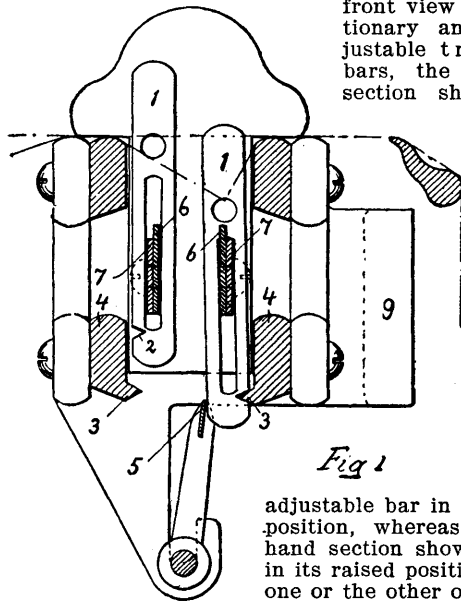
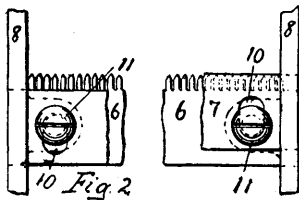

Fig 1

adjustable bar in its lowered position, whereas the right hand section shows said bar in its raised position. Either one or the other of said positions may be used as required.

Each detector 1, has on its lower end an angular notch 2, which is adapted to engage and receive the angular projection 3 on the lower transverse bar 4 when engaged by the feeler 5 to stop the loom in the usual way. The detectors have an elongated opening for the reception of the two transverse guide bars 6 and 7 previously referred to.



The stationary guide bar 6 is secured at its ends to plates 8 on the stands 9 and has a serrated upper edge, into which the detectors drop when a warp thread fails and are thus held to prevent them from twisting. The adjustable guide bar 7 has at each end an elongated slot 10, by means of which it is adjusted, by screw 11, to the stationary guide bar 6. Thus when guide bar 7 is lowered it will leave the teeth of guide bar 6 exposed, and which are covered when guide bar 7 is raised on a level with said teeth. (Crompton & Knowles Loom Works, Worcester, Mass.)

ANOTHER WARP STOP MOTION FOR C. & K. LOOMS.

The improvement relates to that class of warp stop motions in which the detectors are hung between the

lease rods, the object being, in case of a slack warp thread, to prevent its detector from lowering to such an extent as to stop the loom. Guides are also provided for the lease rods to keep them continually at the same distance from the detectors.

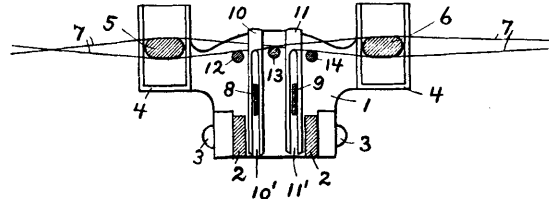

The illustration is a cross section of this warp stop motion.

The end plates 1 of the supporting frame are provided with detector rests 2, secured to the frame by means of bolts 3; said frame extending into vertically slotted brackets 4, in which are mounted the ends of the lease rods 5 and 6.

Extending transversely between the end plates 1 are the two guide bars 8 and 9 for the two sets of detectors 10 and 11, which are made with long, open end slots 10' and 11', through which the guide bars 8 and 9 extend. The detectors 10 and 11 are suspended upon the lower planes of the warp threads 7, one set upon one half of the warp threads and the other set upon the other half of the warp threads and each set between the intersection of the warp threads and a lease rod.

Extending transversely between the end plates 1, and secured thereto, are three parallel rods or rests 12, 13, and 14, one of which (13) extends directly under all of the warp threads 7 at their point of intersection and between the two sets of detectors, and all the warp threads are supported on said rest. Each of the other two rests 12 and 14 extends under the lower planes of the warp threads 7 just outside of the detectors 10 and 11 and inside of the lease rods 5 and 6, and support the lower planes of the warp threads.

It will be seen that all the warp threads are supported on each side of the detectors and close thereto and independent of the two lease rods, so that said detectors are maintained in their normal positions even if there is a sag in any of the warp threads outside of either lease rod, they only dropping into their abnormal position, provided their respective warp thread breaks, and when they drop sufficient below their rests 2 in order to come in contact with the feeler of the stop motion, and thus by means of the regular connections arrest the running of the loom.

The vertical movement of the lease rods in the slots of the brackets 4 allows for any extra tension on either set of warp threads in the operation of the loom. (Crompton & Knowles Loom Works, Worcester, Mass.)

KNOCK OFF ATTACHMENT TO C. & K. WARP STOP MOTIONS.

This attachment is operated from the regular warp stop motion (detectors and feeler) as situated in rear of loom, the object being to insure a positive knock off for the loom. To accomplish this, means are provided whereby when the shipper handle is in its operative position the same will act to lift and retain a dagger lifter in its normal position, leaving the dag-

ger itself sustained by a support; but when a warp thread breaks the feeler and its connections operate to tip said support, in turn allowing the dagger to drop (into operative position) and be struck by the bunter (as fastened to the lay) in turn stopping the loom.

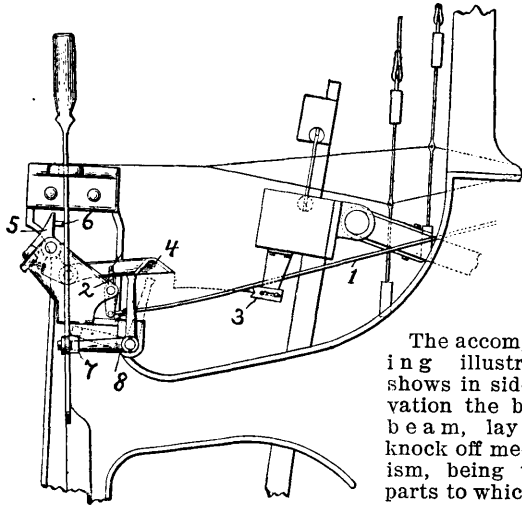

The accompanying illustration shows in side elevation the breast beam, lay and knock off mechanism, being those parts to which the new mechanism

only refers to; the warp stop motion as situated in the rear of loom (not shown) being of usual construction.

Rod 1 forms the connection from the warp stop motion thus referred to, to the new knock off mechanism. When a warp thread breaks the respective detector drops and is engaged by the feeler of the warp stop motion, in turn moving the rod 1 forward, which causes the dagger support 2 to be tipped, allowing the dagger to drop in the path of bunter 3, as adjusted to the lay.

The dagger 4 when thus struck by the bunter 3 operates (through connections shown in dotted lines) the dagger carrier 5 which in turn, through stud 6, knocks the shipper rod from its holding notch and thus stops the loom.

After mending the broken warp thread or threads, the weaver brings the shipper rod into its normal position, which brings a lug 7 to act against the rear end of the dagger lifter 8, turning the same and thus placing said dagger in its normal position, in which it is sustained by its support 2. (Crompton & Knowles Loom Works, Worcester, Mass.)

ANOTHER KNOCK OFF ATTACHMENT TO C. & K. WARP STOP MOTIONS.

The object is to stop the loom through the dagger, from both sources, *i. e.*, in case the warp stop motion operates, or the shuttle improperly boxed.

Fig. 1 is a right hand side elevation of the front portion of a loom showing the construction of the stop mechanism, the lay being shown in its backward position.

K

To the side frame 1 of the loom is secured a stand 2, a dagger carrier 3 being mounted to turn on stud 4 in said stand. The dagger carrier 3 has jointed to it at 5 the dagger 6, the lower portion of said carrier being provided with a stud 7, on which is mounted the main dagger lifter 8, having a cam surface 9 thereon to engage the under side of the dagger and hold the same out of engagement with a bunter 10, as fast on the lay.

The dagger lifter 8 has at its side an extension 11 extending in the path of the shipper lever 17, and at its upper end an extension 12, which extends over the dagger and prevents the same from being thrown back. A spring 13 is connected at one end to an extension 14 on the hub of the dagger lifter 8, and at its other end to a hook 15 on the dagger carrier 13. This dagger carrier at its upper end engages and operates a stop lever 16, pivoted at the under side of the breast beam (said stop lever 16 being commonly actuated to unlock the shipper handle whenever a shuttle fails to be properly boxed in the ordinary way), moving said lever 16 and moving the shipper handle 17 out of its retaining notch, so that it will spring into inoperative position when the dagger 6 is engaged by the bunter 10.

In connection with the main dagger lifter 8, the second dagger support 13 is provided, centrally pivoted on a stud 19 in the stand 2, with its upper end adapted to extend under and engage a projection 20 on the dagger 6. The lower end of the second dagger support 18 has attached to it a connection 21, leading to the warp stop mechanism (not shown), and through which the operation of the dagger support 18 is controlled to move from under the projection 20 on the dagger 6, and allow the dagger 6 to drop into position to be engaged by the bunter 10 on the forward movement of the lay.

When through the breaking of a warp thread, or a warp thread becoming too loose, the second dagger support 18, through connection 21, is moved from beneath the dagger 6, said dagger will drop into position to be engaged by the bunter 10 on the forward stroke of the lay, the dagger lifter 8 being held in its backward position out of engagement with the dagger 6 by the engagement of the shipper lever 17

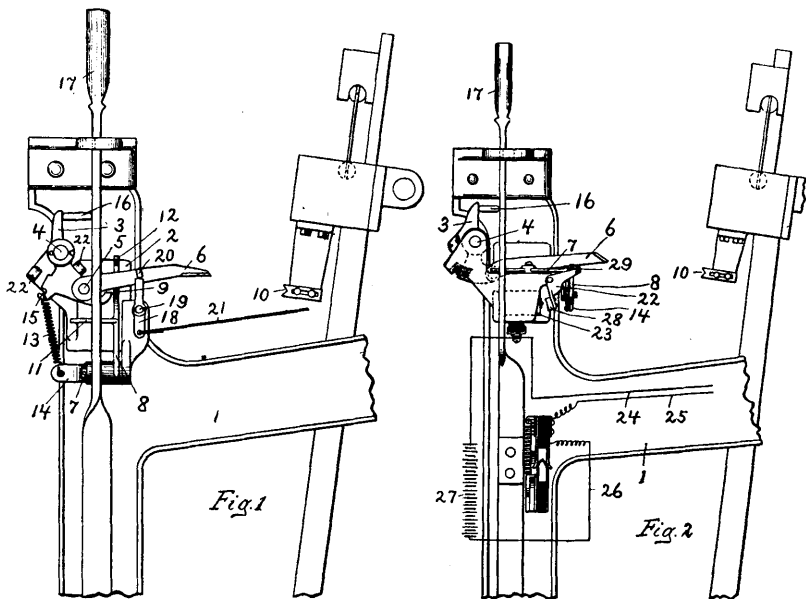

with the side extension 11 on said dagger lifter 8. The engagement of the bunter 10 with the dagger 6

will move the dagger carrier 3 on its pivot 4 to cause it to actuate the stop lever 16 to move the shipper lever 17 out of its retaining notch, and allow it to spring back and operate to stop the loom in the usual way.

Upon the movement of the shipper lever 17, as described, the spring 13 immediately acts to rotate the dagger lifter 8 on its supporting stud 7, and move the cam surface 9 under the dagger 6 to raise said dagger and move it out of the path of the bunter 10, as seen in Fig. 1. At the same time the spring 13 acts to move the dagger carrier 3 on its pivot stud 4 away from the stop lever 16, a stop 22 on the stand 2 limiting the movement of the dagger carrier 3. The dagger 6 is thus put into a position where it cannot be struck a second time by the bunter 10, and also into a position where the second dagger support 18 can be moved under the dagger 6 to support it. The movement of the shipper lever 17 by the hand of the operator to put the loom into operation will cause it to engage the extension 11 on the dagger lifter 8 and move the dagger lifter 8 out of engagement with the dagger 6, while the second dagger support 18 immediately returns to its normal upright position, thus leaving the parts in an operative position.

This same mechanism may also be used in connection with an electric warp stop motion, for which reason the illustration Fig. 2 is given, being a side view, clearly showing the operation of the stop mechanism when operated by the electric stop motion previously referred to. In this instance an electromagnet 23 is, by means of the wires 24, 25, and 26, in electric circuit with the binding posts on that part of the warp stop motion at the rear of the loom.

When a warp thread breaks or becomes too slack, the electromagnet 23 is put into electric connection to complete the circuit and establish a current derived from the battery 27 and thus the electromagnet 23 is energized. Under said conditions the armature 28 as attached to the angle lever 22 of the dagger lifter 3 will be drawn toward the electromagnet 23, and said angle lever 22 moved in opposition to its spring to allow the dagger 6 to fall into the path of the bunter 10. The downward movement of the dagger lifter 22 will allow the spring 14 to move the latch 8 and cause an extension thereon to engage and extend over the upper edge of the lifter 22. The dagger 6 is now in the position to be struck by the approaching bunter 10 to turn the dagger carrier 3 on its pivot 4, and through the knock off lever 16 to disengage the shipper lever 17 from its holding notch, and thus stop the loom. The movement of the shipper lever 17 releases the centrally pivoted lever 7, and allows the spring 29 to act to move said lever, and through said lever to move the latch 8 out of engagement with the lifter 22 against the action of the spring 14, and allow the spring of the dagger lifter to act to move the dagger lifter 22 and withdraw the armature 28 from the magnet 23, thus interrupting the circuit as the loom is stopped. (Crompton & Knowles Loom Works, Worcester, Mass.)

WARP STOP MOTION FOR C. & K. SILK LOOMS.

In weaving silk goods or cotton fabrics having a high warp texture, it is impossible to use a common warp stop motion, since there is not room for all the detectors thus required to work properly.

To overcome this difficulty is the object of the stop motion shown in the accompanying illustration in its cross section, *i. e.* a stop motion using three series of detectors.

In this illustration numerals of reference indicate thus: 1 the warp beam, 2 the whip roll over which

the warp threads 3 pass. 4 and 5 are warp supporting bars extending transversely across the loom and are supported at their ends in a frame (not shown). Between the warp supporting bars 4 and 5 are three sets of detectors 6, 7, and 8, arranged in three parallel rows. Each detector has an elongated opening *a* in its upper part and an elongated opening *b* in its lower part, which has one end open, as shown, and there is an opening or warp eye *c* in the central part between the openings *a* and *b* for a warp thread to pass through, and by means of which the detector is supported in its normal position when the warp thread is not broken or too slack.

There is a guide bar 10 for each set of detectors, which extends through the upper openings *a* and guides, and holds the detectors at their upper ends, and also limits the downward motion or drop of said detectors when a warp thread 3 is

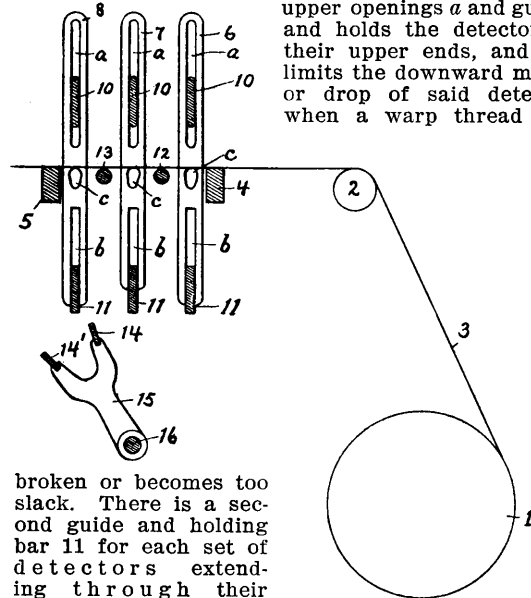

broken or becomes too slack. There is a second guide and holding bar 11 for each set of detectors extending through their lower openings *b* to guide and hold said detectors at their lower ends.

Between the three series of detectors extend two transverse rods 12 and 13, supported at their ends, and which act to support the warp thread between the detectors.

In connection with the detectors, and forming a part of the warp stop motion, are employed two feeler blades 14 and 14', secured at their ends upon the forked end of a rocking arm 15, fast on a rock shaft 16, to which a regular rocking motion is communicated. It will be seen that the feeler blades 14 and 14' on the rocking arm 15 move in the arc of a circle, and consequently if the lower ends of the three sets of detectors 6, 7, and 8 are in the same horizontal plane, the lower ends of the middle set of detectors 7 will be nearer the arc of movement of the feeler blades 14 and 14' than the outside detectors 6 and 8, for which reason the middle set of detectors 7 are shortened at their lower ends, so that in case of any slight slackness of the warp they will not be lowered sufficiently to come in the path of or be engaged by the feeler blades 14 and 14'. (Crompton & Knowles Loom Works, Worcester, Mass.)

WARP STOP MOTION FOR DRAPER LOOMS.

Fig. 1 is a sectional view of a loom having this stop motion applied thereto, and Fig. 2 shows the manner in which the detector engages the crossed warp threads, and by means of which crossing said detector is held in normal condition.

a indicates the knock off lever, pivoted to the loom

frame and being pivotally connected at a^1 with a knock off rod a^2 mounted to slide in bearings q^3 on

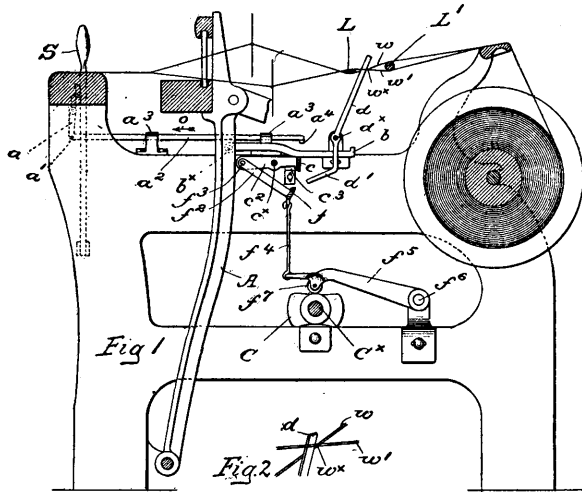

the loom frame, the rear end of this rod having an offset a^4 .

A bunter b is pivoted to one of the lay swords A at b^x , said bunter being guided by a flat bar support c , set upright, and having its lower edge toothed and attached at its ends to arms c^2 , fulcrumed at c^x on the loom frame, a stop c^3 limiting the downward movement of this support c . f indicates a feeler, having a notched edge, said feeler being attached to rocker arms f^2 (one on each side of the loom) fulcrumed at f^3 on the outer ends of the arms c^2 .

The link f^4 connects the rocker arm f^2 with a lifter arm f^5 , fulcrumed at f^6 , being provided with a roller f^7 , which travels on the cam C mounted on the cam shaft C^x , and by which means the feeler f is vibrated. A series of detectors d are pivotally mounted on a transverse rod d^x , as extends across the loom, the lower ends of the detectors being bent at d' toward the path of the feeler f .

The upper end of each detector is extended between the lease rods L, L' to engage a pair of cross threads w, w' , at the crossing w^x thereof, as shown most clearly in Fig. 2, it being shown therein that the detector crosses either warp at the side opposite to which said warp engages the other one of the pair. The detectors will be maintained in the position shown in both illustrations, and thus are kept inoperative so long as the crossed warps of each bar remain intact, but should either warp fail, then the detector will be free to slide along the other warp toward the back of the loom, the portion of each detector above its fulcrum being the heavier, such movement of the detector into operative position interposing its finger between the feeler and bunter support c . After such interposition, the feeler will at its next upward stroke, engage the finger and press it against the toothed edge of the support c , so that at that time the feeler and the support will rock in unison on the fulcrum c^x to thereby raise the bunter b , so that at the next forward movement of the lay the bunter will engage the bent end a^4 of the knock off rod and move the latter in the direction of the arrow o , Fig. 1, to release the shipper handle S , and thereby stop the loom. Under normal conditions the feeler is vibrated about the fulcrum f^3 , and relatively to the bunter support c , but the interposition of the detector finger d' will cause both the support and feeler to move in unison on the fulcrum c^x .

The notching or serrating of the opposed jaws of

the bunter support c and of the feeler f , respectively, prevents twisting of the finger portion of the detector when interposed therebetween. (Draper Co., Hopedale, Mass.)

YIELDING WARP REST FOR DRAPER LOOMS.

This warp rest is used in connection with a warp stop motion mechanism in which the heddles serve as detectors, the object being to secure positive lifting of the detectors when in the lower shed out of accidental engagement by the feeler.

The illustration is a vertical sectional view of a portion of a loom, showing this warp rest applied thereto.

The same consists of a bar a extended across the loom in rear of harness and below the warps, being formed with journals adapted to rock in bearings of brackets b , secured to the loom frame. A spring (not shown) surrounds one of the journals of the warp rest, tending to lift the same upwards.

When the warps w are moved into the lower shed, as shown in the illustration, they press on the warp rest, and consequently depress it from the dotted line position against the action of its lifting spring; the tension thus imparted to the warps acting to lift the detector heddles positively out of accidental engagement by the feeler f . (Draper Co., Hopedale, Mass.)

SIGNAL ATTACHMENT TO WARP STOP MOTIONS FOR DRAPER LOOMS.

This attachment is applied to the detectors of warp stop motions of the usual construction, the object being to show to the weaver, by means of the position

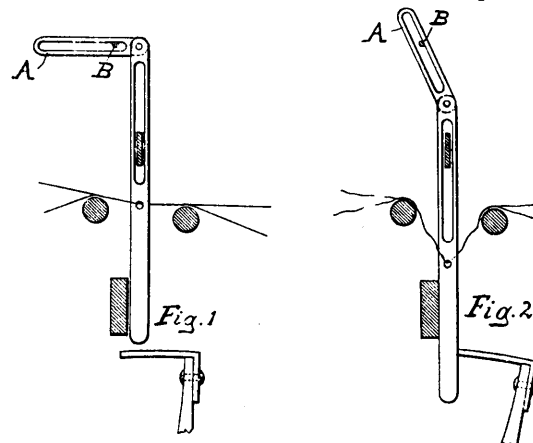

of said attachment, at a glance where a certain warp thread is situated, which, by means of breaking, had

caused the stopping of the loom. Fig. 1 shows the attachment (and also its detector) in its normal position; Fig. 2 showing said attachment in the position the same occupies when its respective warp thread has been broken (the detector dropped).

The attachment consists of a slotted lever A, movably pivoted to the top of the detector. The prominent change of position of the attachment (signal to the weaver) is caused by means of a rod B passed through the slot of the attachment. This rod B is fastened on each end to the two side frames of the loom, and acts as a fulcrum for guiding the attachment from its normal to raised position caused by the drop of the detector, and vice versa, from its raised to its normal position, caused by the weaver lifting the respective detector to mend the broken warp thread. (Draper Co., Hopedale, Mass.)

BRAKE MECHANISM FOR NORTHROP LOOMS.

On pages 79 and 80 of Textile Machinery, Part 2, the principle of this mechanism has been described, the present improvement having for its object the

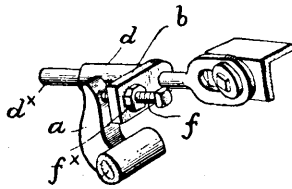

production of means whereby the mechanism is capable of finer adjustment, to be efficient in all circumstances, thus preventing cracks in the cloth, as was more or less the case with the former construction previously mentioned.

The illustration is a perspective detail of the means for effecting the fine adjustment of this brake mechanism before referred to.

In the construction explained in Part 2 of this work, a toe *a* acts directly upon the collar *d* to move the brake rod *d** longitudinally to the right to apply the brake when the loom is stopped; but in the new construction an adjustable abutment *f* is mounted on the collar, to be engaged by the toe *a* of the actuator when the latter operates. A lateral extension *b* on the collar *d* is provided with a threaded hole to receive the screw *f*, which constitutes the adjustable abutment, a check nut *f** locking the latter in adjusted position, the rear end of said abutment being located in the path of the toe *a*. By turning the screw *f* in one or the other direction, the engagement therewith by the toe *a* of the actuator will be delayed or accelerated correspondingly, so that the application of the brake is adjusted or varied relative to the operation of the stopping means. (Draper Co., Hopedale, Mass.)

FILLING STOP MOTION FOR C. & K. LOOMS.

The object is to provide a positive mechanism for controlling the downward movement of the filling feeler fingers which rest upon the filling after every

passage of the shuttle through the shed, and on the absence of the filling are moved downwardly into a recess on the top of the lay and through intermediate connections raise the knock off dagger to a position where it will engage mechanism on the breast beam on the forward beat of the lay to in turn stop the loom.

The illustration is a sectional side elevation of parts of a loom with the new device applied thereto, showing the filling feeler fingers or wires in their raised position.

Examining the illustration, we find that on the bottom shaft 1 of the loom is fast a cam 2, the periphery of which engages one end 3 of a lever 4, centrally pivoted on a stud 5 on a bracket 6, bolted to the girth 7. A spring 8, attached at one end to the lever 4 and at its other end to an extension 9 on the bracket 6, acts to hold the end 3 of the lever 4 in engagement with the cam 2 on the bottom shaft 1.

On the opposite end of the lever 4 from the end 3 is a slot 10, which receives a stud 11, fast to the lower end of the vertically moving rod 12, which has a bearing at its upper end in an extension 13 on the stand 14, secured to the front side of the lay 15.

On a stud 16, secured to the stand 14, is pivotally mounted a rocking lever 17, having secured thereto at its front end 18 the knock off dagger 19. The rear end of the rocking lever 17 has a cam surface 20 thereon, which extends directly over and is engaged by the upper end of the vertically moving rod 12. On the stud 16 is secured a coiled spring 21, the free end 22 of which engages a lug 23 on the rocking lever 17, and thus acts to hold the end 20 of said lever in engagement with the upper end of the rod 12.

To the rocking lever 17, at the rear of its pivot stud 16, is pivotally attached at 24 the lower end of a connector or link 25. The upper end of said connector 25 is pivotally attached to a stud 26 on a

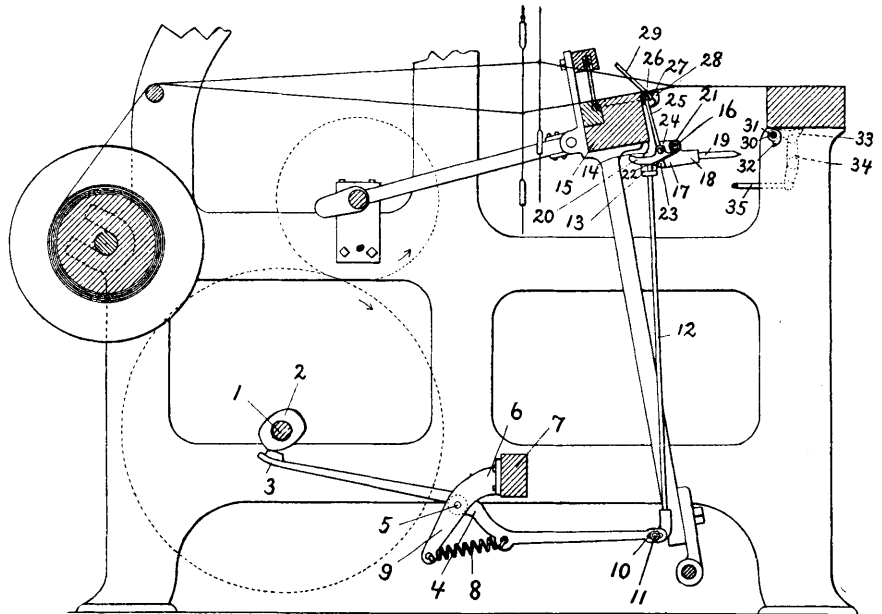

crank 27, as is fast on a rock shaft (not shown) journaled in bearings 28 at the upper end of the stand 14. The filling feeler fingers 29, as fast on this rock shaft (not shown), are operated by the crank 27 and move with said shaft.

Extending under the breast beam is a rock shaft 30, having fast thereon a collar 31, with an extension 32. On the end of the shaft 30 is a latch 33 (shown by broken lines), which engages the upper end of a

centrally pivoted lever 34, the lower end of which is secured to a connector or rod 35, which operates to stop the loom.

The operation of the mechanism is as follows: As the lay beats up, the cam 2 on the bottom shaft 1 is partially revolved, and the lever 4 is moved on its pivotal support, causing the rod 12 to be lowered and allowing the spring 21 to act to move the lever 17, and through the connector 25 and crank 27 move down the filling feeler fingers 29 upon the filling thread, which if not broken, prevents said fingers from completing their full downward movement into the recess in the lay, and the dagger 19 on the lever 17 is held in a position in which it will not engage the projection 32 on the collar 31. In case of the absence of the filling thread on the forward beat of the lay, the spring 21 (the end 3 of the lever 4 being on the low part of the cam 2) will move the lever 17 and cause the filling feeler fingers 29 to be moved to their lowest position into the recess in the lay, and consequently the dagger 19 to be raised to a position where on the forward beat of the lay it will engage the projection 32 on the collar 31, and in turn stop the loom. (Crompton & Knowles Loom Works, Worcester, Mass.)

FILLING STOP MOTION FOR NORTHPROP LOOMS.

The object is to permit the weaving of either fine or coarse goods on the same loom. When weaving fine goods, and the filling breaks, the filling changing mechanism will then not operate, and the loom stops, in turn permitting the weaver to remove the part of a pick caused by said breakage, and insert a full pick, thus preventing imperfections in the fine cloth (which in coarse cloth would not be objectionable), and

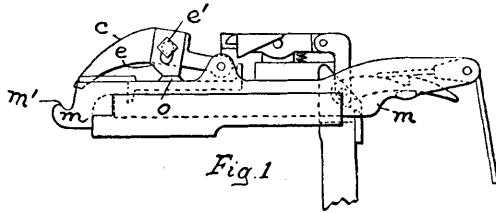

when then the filling changing mechanism is brought in action any time upon breakage of a thread.

Fig. 1 is a side elevation of the filling fork and its cooperating parts. Fig. 2 shows in elevation the lock coupling which determines whether the filling supplying mechanism shall operate or not.

In the construction of this stop motion, the outer end of the filling fork slide *m* is provided with an upturned hook *m¹*, into which enters the downturned end of an arm *d*, having its hub *d¹* loosely mounted on the rock shaft *a* and being further extended into an arm *d²*, which operates to effect the disengagement of the take up pawl when the filling fails.

The knock off lever *n¹* is fulcrumed at *n*, the end *n²* passing under the bend of an arm *b* and being upturned at *n³* in the path of a dog *c*, which is provided with an adjustable cam *e* normally resting on a projection *o*. When the filling fork slide moves, the dog *c* drops down on the top of the end *n³* of the knock off lever, thus releasing the shipper handle and stopping the loom. The hub *d¹* is shouldered at *f* to engage the opposite shoulder *g* on a collar *h*, also mounted on the rock shaft *a* and adapted to be secured thereto by a set screw *i*. The collar *h* serves as a lock coupling, to at times connect the arm *d* with the rock shaft, for if the collar is made fast on the rock shaft by the set screw *i*, when the

arm *d* is swung outward by the slide, the shoulder *f*, acting on shoulder *g*, will operate to turn the rock shaft *a* and effect the actuation of the filling supplying mechanism.

On the other hand, if the collar *h* is loose on the shaft, the rocking of the arm *d* will have no effect upon the rock shaft *a*, nor consequently upon the filling supplying mechanism. If, therefore, coarse or common cloth is to be woven, the lock coupling will be made operative by securing the collar *h* to the rock shaft, so that if the filling breaks the filling

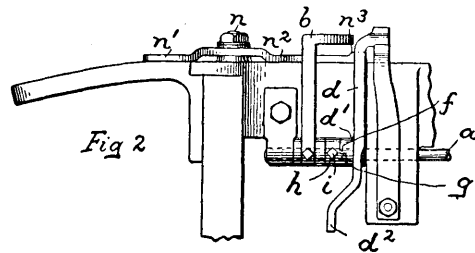

supplying mechanism will be actuated, and at such time the cam *e* will be set on the dog *c*, to operate, as previously described.

Should the loom be weaving fine goods, however, in which part of a pick must be removed, the lock coupling *h* is simply released, so that the shaft *a* will not be rocked upon failure of the filling, and at the same time the set screw *e¹* will be loosened and the cam *e* will be raised on the dog *c*. This permits the free end of the latter to drop behind the end *n³* of the knock off lever, and at the first outward movement of the slide *m* due to filling failure, the dog will operate the knock off lever to release the shipper handle, and thereby stop the loom, to permit the weaver to remove the part of a pick and insert a full one. (Draper Co., Hopedale, Mass.)

PICKING MECHANISM.

ROY'S PICKING MECHANISM.

The novelty in this construction of a picking mechanism consists in means, whereby said picking mechanism may be readily connected or disconnected by the weaver without affecting the running parts of the loom.

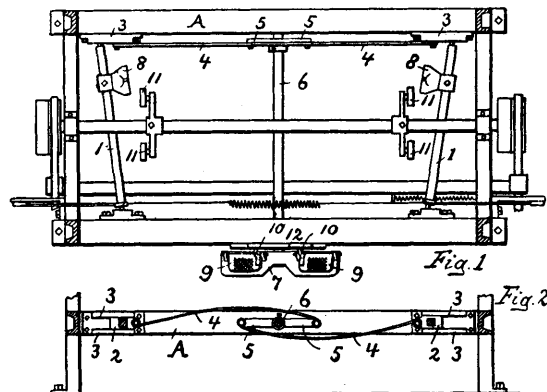

Fig. 1 is a horizontal sectional view of the lower portion of a loom, showing, in plan, the picking mechanism in inoperative position. Fig. 2 is a vertical sec-

tional view, showing a portion of the mechanism by which the picker shafts are shifted.

Each picker shaft 1 is pivoted at one end in sliding boxes 2, sliding in brackets 3 secured on the rear girth A of the loom. Each sliding box 2 is connected by links 4 with the ends of radial arms 5 carried on a rock shaft 6. The forward end of this shaft 6 is provided with a two armed foot treadle 7, provided with the two foot plates 9. Each of the foot plates 9 is provided with fingers 10 adapted to enter holes in a plate 12 to secure the treadle in either of its two positions.

When the weaver places his foot on one of the plates 9, he thus rocks the treadle into operative position, the arm 5 operating to slide the boxes 2 so as to bring the picker shoes 8 into engagement with the picking rolls 11. When for one reason or the other, it is desired to throw the picking mechanism out of operation, the weaver, by placing his foot on the opposite foot plate 9, thus rocks the treadle 7 into its inoperative position, the arm 5 operating to slide the boxes 2, and in turn moving the picking shoes 8 out of engagement with the picking rolls 11, and this without interfering with the running parts of the loom. (B. S. Roy & Son, Worcester, Mass.)

GLEASON'S PICKER CHECK.

The object is to produce a picker check that shall bring the shuttles to a quick and easy stop without any rebound.

The illustration shows a vertical section of the check as attached to the under side of the shuttle box.

A bracket 1 is attached to the under side of the shuttle box 2 and a screw threaded hole is cut in said bracket for receiving a stud 3, which has a collar 4. A ratchet wheel 5, two friction washers 6, 7, and a spring washer 8 are fitted to go on the stud 3 on one side of collar 4, and a lever 9 is fitted to swing on the stud 3 on the other side of said collar 4.

A double ended pawl 10 is held on a screw stud 11, and a hole 12 is made in the lever 9 to receive a spring 13, which tends to press on one side of this pawl 10. Pressure is applied to ratchet wheel 5 between the collar 4 and bracket 1 by means of spring washer 8, the tension thus produced being regulated by the nut 14.

Weight 15 is adjustable on the lever 9, to regulate power required to return lever 9 to its normal position.

The operation of the device is as follows: The normal position of the lever 9 is vertical, and when the picker is struck by the incoming shuttle, the stick falls back against the horizontal arm at the lower end of the lever, which is bent off so as to cross its

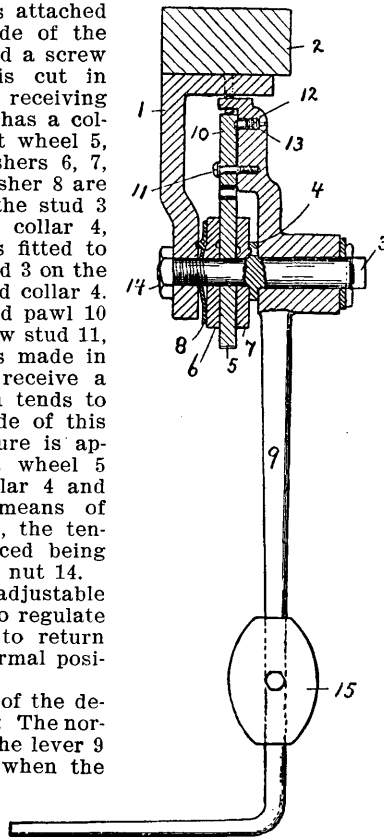

path, and the friction on the ratchet wheel 5, which is turned by the pawl 10, brings the picker stick and shuttle easily to a rest without the risk of the rebound.

By reversing the ratchet wheel on the stud and depressing the other end of the pawl to engage with the reversed ratchet wheel, this check can be made applicable to either a right or left hand shuttle box. (Wilkins Mfg. Co., Woonsocket, R. I.)

CONNECTION OF PICKER ARM AND ROLL.

The object is to provide improved means for adjustably securing to the picker arm the support or collar on which the picker roll is mounted.

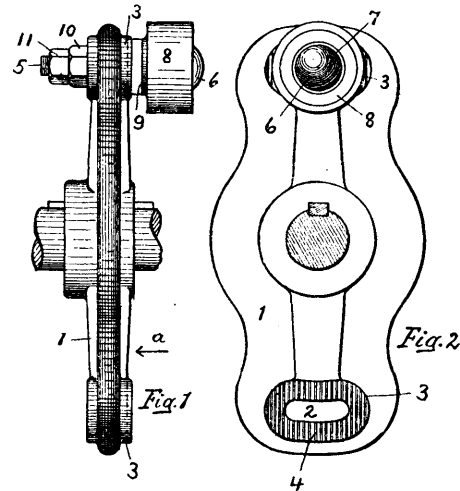

Fig. 1 is an edge view of a picker arm with one roll thereon, shown mounted on the cam shaft. Fig. 2 is a side view of the parts shown in Fig. 1 looking in the direction of arrow a, same figure.

At each end of the picker arm 1 there is provided an elongated transverse slot 2, surrounded on one side by a raised portion 3, which is provided with teeth 4 arranged in parallel rows. A bolt 5 extends through the slot 2 and also through a bushing or sleeve 7. The head 6 of the bolt 5 bears on the outer end of the bushing 7 and has a fin 7 thereon, which extends into a recess in the bushing 7 to prevent said bushing from turning on the bolt. The surface of the inner end of the bushing 7 is provided with teeth corresponding in size to the teeth 4 on the raised portion 3 of slot 2, being adapted to engage with said teeth 4, round the slot 2. A roll 8 (only one roll is shown in illustration) is loosely mounted on the bushing 7, and is held in position thereon by an annular shoulder 9 on the bushing 7 and the head 6 on the bolt 5. A nut 10 on the bolt 5 secures the bolt in the slot 2 and binds the bushing 7 to the toothed part around the slot 2, and a check nut 11 holds the nut 10 in place. The elongated slot 2 permits of adjustment of the bolt 5 to change the position of the bushing 7 and roll 8 as desired. (Crompton & Knowles Loom Works, Worcester, Mass.)

AN ALUMINUM SWEEP STRAP.

The object is to produce a light and durable sweep strap.

The illustration is a side elevation of the sweep strap as connected with the picker stick.

A indicates a stationary bracket secured to the loom (not shown), in which bracket is secured a

stud bolt *a*, on which is fulcrumed the picker stick B. C is a raw hide support, the lower end of which is enlarged and provided with two sets of holes *c*, adapted to receive the end of the bolt *a*, on which said support is pivoted by means of jam nuts *a*¹, and by which proper adjustment of the picker stick is secured. The upper end C¹ of this support is provided with a transverse hole, which encompasses a stud pin *d*, affixed to one of the parallel arms *d*¹ of the sweep strap.

E represents the sweep stick, secured between the parallel sides *d*¹ of the sweep strap by the bolts *e*, the picker stick having a limited amount of play in said sweep strap. Plate F is secured to one of the arms *d*¹ by bolts *e*, its body portion being formed with an offset *f*, which encompasses the stud *d* on the outside of the support C to retain said support in place.

The entire sweep strap and the stud *d* is made of aluminum or an aluminum alloy, on account of its light weight and general adaptability for this purpose. By making the raw hide support in two pieces the best possible form of bearing for the coating parts with the minimum amount of friction and no possibility of binding are obtained. (L. S. Watson Mfg. Co., Leicester, Mass.)

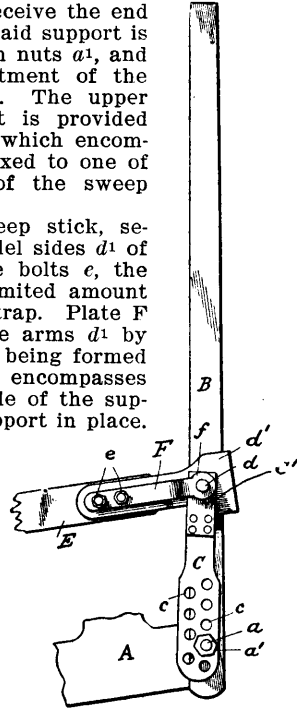

KELLEY'S PICKER ACTUATING MECHANISM.

This picker stick connection provides means for maintaining the striking face of a striker block as carried by the lug strap parallel with the contacting face of the picker stick at all points of their swing,

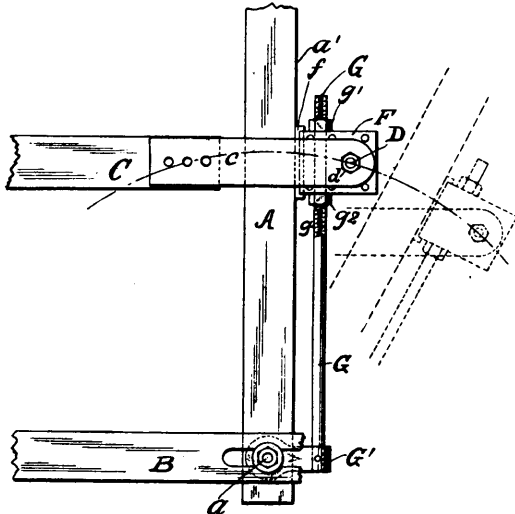

while at the same time permitting a limited swing of the striker block free of the picker stick. This arrangement will result in providing a picker stick connection able to withstand satisfactorily the hard service a picker stick as well as lug strap is sub-

jected to, identical to the jerky character of the operation of "picking." The mechanism also provides means for ready adjustment of the lug strap to any leverage, *i. e.*, power for picking required.

The accompanying illustration is an elevation showing the lower portion of a picker stick in vertical, *i. e.*, picking position, and having Kelley's actuating mechanism applied thereto, another position of the parts (picker stick, etc., at rest), being indicated in dotted lines.

A indicates the picker stick, which is pivoted at its lower end *a* to a fixed part B of the lay sword. C is a portion of the sweep stick, having suitably connected to it the lug strap *c*, the latter loosely spanning the former and projecting beyond it. This lug strap end *c*, is formed of two plates, rigidly connected at their outer ends by means of a bolt *d*, having a spacing sleeve (not shown) thereon, and a nut *d*. Upon this spacing sleeve is loosely mounted between the strap plates a striker block F, provided with a removable striking face *f*, of leather, which forms a flat bearing surface of substantial extent to contact with the edge *a'* of the picker stick. For conveniently carrying as well as positioning the lug strap *c* and at the same time for maintaining the striking face of the striker block F parallel with the contacting face of the picker stick A at any point of their swing, a supporting mechanism is provided, comprising a swinging arm G, pivoted concentrically with the picker stick at *a* by means of an attached piece G', so as to swing with the latter, and which is so connected with the striker block F as to maintain the latter in fixed relation thereto in their joint movement around the pivot *a*. This connection is effected directly and adjustably by passing the screw threaded end *g* of the swinging arm through a drilled hole in the striker block F and rigidly securing the same thereto at a properly adjusted height from the pivot *a* by means of nuts *g*¹, *g*², on the threaded end of the arm, which end is arranged parallel with the contacting edge *a'* of the picker stick, while its pivotal end is mounted upon the common pivot *a*. It will be readily seen that by means of the construction of a picker actuating mechanism thus described, the striking face of the block F is at all times maintained square with the contacting edge *a'* of the picker stick, thus distributing the strain and wear of the jerky action of picking upon all parts of the picking mechanism. (W. H. Kelley & Co., Reading, Pa.)

ATTACHMENT TO THE PICKING MECHANISM.

To prevent breakage of the picker stick and its cooperating parts, in case said picker stick is accidentally locked against movement.

By means of the illustration, which is a side elevation of this attachment, we see that the hub of the picker shaft arm H is formed with teeth, which are normally in engagement with corresponding teeth in a clutch member I as fastened to the picker shaft J. The engagement of these clutch members is maintained by an adjustable spring P.

When the picker stick is locked in case of any obstruction, the teeth of the clutches are disengaged from each other by the action of the picking mechanism, the spring P being compressed, and thus the

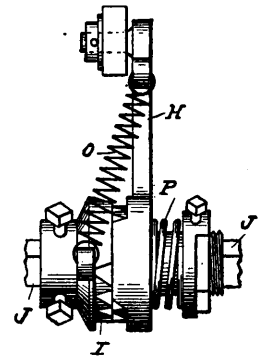

picker stick and its coöperating parts prevented from breakage.

After the picker stick has been liberated from its obstruction, a spring O, as attached to the clutch members, returns them to their normal (locked) position. Spring O, however has been lately omitted by the builder of the attachment, thus making the latter more simple and less expensive. (Ephraim M. Keffer, Hespeler, Ont.)

A YIELDING PICKER CHECK.

The accompanying illustration is a side elevation of this picker check, as is applied to the rear end of the shuttle box. The check consists of a main body portion A, bent at B, and provided with an arm C. D is an opening by which the check is secured to the shuttle box. E is a stud on the body portion A, to which is attached strap F, said strap extending

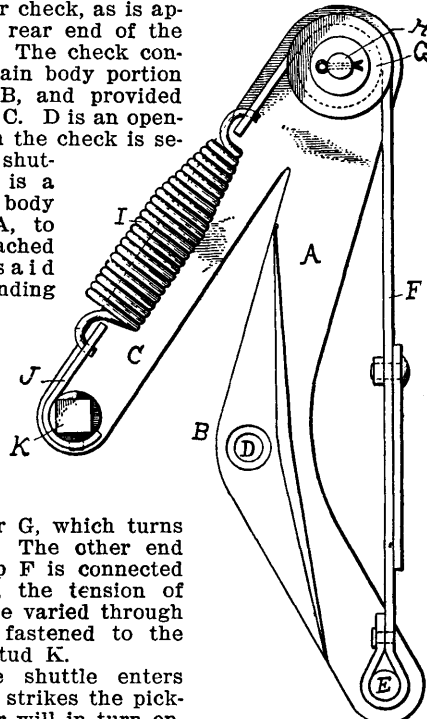

over a roller G, which turns on stud H. The other end of this strap F is connected to spring I, the tension of which can be varied through strap J as fastened to the adjustable stud K.

When the shuttle enters the box and strikes the picker, the latter will in turn engage the spring yielding strap F, thus checking the shuttle gradually. (Homer F. Livermore, Boston, Mass.)

SHUTTLE CHECK FOR KILBURN LINCOLN LOOMS.

In this shuttle check, the shuttle binder is pivoted near the entrance of the shuttle box instead of near the picker end, as heretofore done, thus the pressure of the binder on the shuttle is instantly released when the shuttle is thrown from the box. The illus-

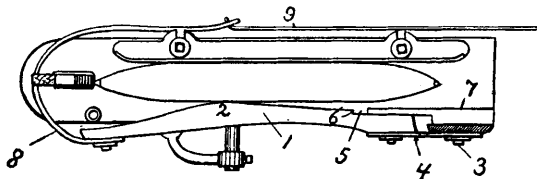

tration is a plan view of the shuttle box with the top removed, showing the shuttle held by the binder and its co-operating parts.

The shuttle binder 1 having the swell 2 is pivoted at 3 to the wall of the shuttle box, the hinge or pivot 4 being of a flexible nature, thus permitting a slight

lateral movement of said binder. To permit adjustment of the binder, a space 5 is left between the end 6 of said binder and the wall 7 of the shuttle box.

A check strap 8 is attached at one end to the shuttle binder, its other end passing behind the picker, is fastened to a connection 9, which extends across the back of the lay and in turn is connected to a like strap on the opposite shuttle box. When the shuttle enters the box, the picker stick strikes the strap 8, thus compressing said strap, in turn drawing the binder into the shuttle box to bear said binder against the shuttle. This pressure is instantly released the moment the shuttle is ready to be picked, i. e., the picker stick starts. (Kilburn, Lincoln & Co., Fall River, Mass.)

SHUTTLE MOTION FOR C. & K. SWIVEL LOOMS.

The object of the mechanism is to provide a bearing for the swivel shuttle independent of the bearing of the "horse shoe" gear, and to reduce the bearing of the same and bring it nearer the central portion thereof, to lessen the friction.

Fig. 1 is a front view of a portion of the swivel shuttle motion, showing one of the shuttles at its lowest point of movement. Fig. 2 is a vertical cross section on line 3-3, Fig. 1, looking in the direction of arrow a, same figure.

1 indicates the back box plate, having in its lower portion a series of openings 2 of equal diameter and of equal distance apart. A face plate 4 extends over the back box plate, being secured thereto by screws 5, and has a series of openings 4' in its lower portion. The openings 2 are provided with passage ways

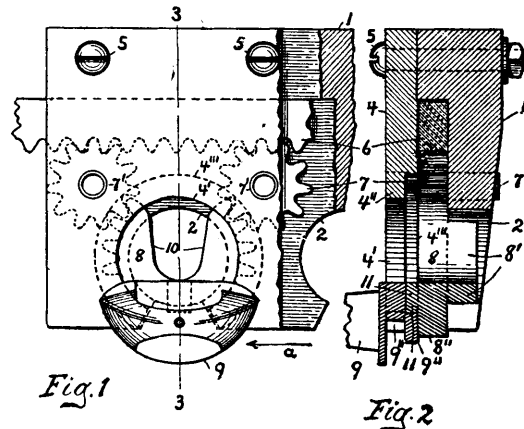

(shown in dotted lines Fig. 1) for the entrance of the warp threads from below into the openings 2 when the shuttle is in its upper position.

The front portion of the back plate 1 is cut away, as shown in Fig. 2, to leave a space between the back plate 1 and the face plate 4 for the horizontal moving driving rack 6, the pinions 7 and the horse shoe gears 8. The pinions 7 are mounted on pins 7', extending transversely through the back plate 1 and the face plate 4, as shown in Fig. 2.

The horse shoe gears 8, which move the swivel shuttles 9, have a hub 8' thereon made integral with the tooth portion 8'', as shown, and are provided with the U-shaped opening 10 therein. The hub 8' on the gear 8 extends into and has its bearing in the circular hole 2 in the back plate 1. On the front of the tooth portion 8'' of the horse shoe gear 8 is a projection 11, which extends into a correspondingly shaped

recess in the lower surface of the shuttle 9 to cause it to move with the gear 8 as the same is operated by the pinions 7 and the rack 6.

The inner end or lower part of each swivel shuttle 9 has an annular groove 9' therein, into which extends the edge around the opening 4' in the front plate 4, said edge 4" around the opening 4' in the front plate 4, forming a bearing surface for the swivel shuttle 9 to travel on, independent of the horse shoe gear. The projection or flange 9", forming the lower side of the groove 9', extends into and travels in the undercut channel 4"', around the opening 4' in the front plate 4.

By making the horse shoe gear 8 with the extended hub 8' at its central portion, which has its bearing in the opening 2 in the back plate 1, the bearing surface, and consequently the friction, is reduced, and by making the swivel shuttles with the annular groove therein, into which extends the edge around the opening on the front plate, an independent bearing for the shuttle is provided, and the shuttle is not rigidly secured to the horse shoe gear, but only connected with it through the projection 11 thereon, extending into the recess in the shuttle, previously referred to, so that the shuttle can be readily detached from the gear by removing the front plate 4. (Crompton & Knowles Loom Works, Worcester, Mass.)

SHUTTLE DRIVE FOR NARROW WARE LOOMS.

The object of this mechanism is to provide means whereby the shuttles are started promptly on the formation of the shed, and this with constantly increasing speed, which in turn is gradually stopped after the shuttle passed through the shed.

The illustration is a side elevation of this driving mechanism, shown detached from the loom.

The crank shaft C passes through an eccentric F, on which is loosely mounted the driving gear G. On this gear G is fixed a pin a^2 which enters the slot a^1 in arm a , secured to the crank shaft C.

In mesh with the gear G is the motion transmitting gear H, mounted on a stud h , as fast on the loom frame. This gear carries a crank arm i , which is secured thereto at each end by pins i^2, i^3 , respectively. To these pins are connected the

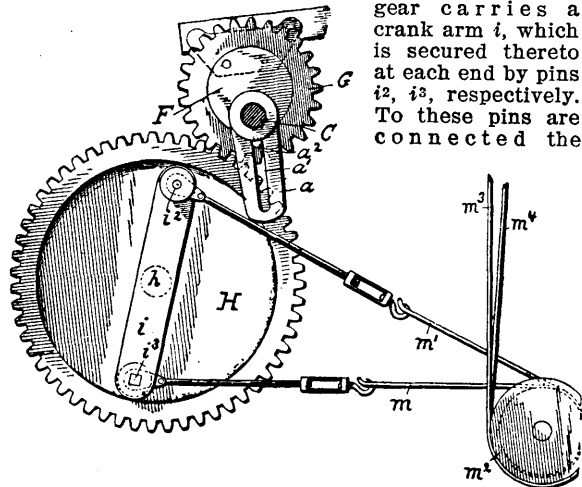

straps m, m^1 , by which motion is imparted to the shuttles through disks m^2 , and straps m^3, m^4 , as connected to a second disk (not shown) for reciprocating the rack bar of the loom.

How the Speed of the Shuttles is Varied: As the crank shaft C revolves, the eccentric relation be-

tween the shaft C and pinion G causes the pin a^2 to travel in the slot a^1 of arm a , and a consequent decrease of motion is thus continuously imparted to the gear H and arm i as the latter approaches its position of most effective motion transmission. As the pin a^2 travels toward the outer extremity of the slot a^1 , a gradual increase in the motion imparted to arm i takes place until the shuttle passes through the shed, and when the action is repeated. (Insinger Loom Co., Phila., Pa.)

SHUTTLES.

HALL'S SELF THREADING SHUTTLE.

The invention here presented is a small fitting (a threader), which can be applied to all classes of shuttles at small expense, by means of which the shuttle may be threaded with the filling either from bobbin or cop.

Of the accompanying illustrations Fig. 1 shows the threader before it is applied to the shuttle, and Fig. 2 the threader applied to the shuttle.

The new threader consists of a small and light steel plate, with flange and point adjusted in such a way that the filling from the cop or bobbin in the ordinary shuttle when drawn through a slot in the shuttle is guided down and out through the eye at the side of the shuttle, and once having passed through the guide, the shuttle cannot become unthreaded by any back throw or balloon of the thread.

The advantages claimed are: (1) The avoidance of the unhealthful practice on the part of the operators of sucking through the ordinary eye by the

mouth the small wad or ball of the filling twisted up and placed at the inside of the eye by the finger. (2) It avoids the necessity of looking up the threading hook by which the filling is hooked through the eye of the shuttle where the placing of the eye or eyes will admit of this method of threading. (3) It

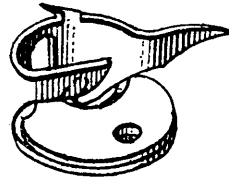

Fig. 1.

is a means of saving of waste, as there is no wadding into a ball of the filling, in order to get it through

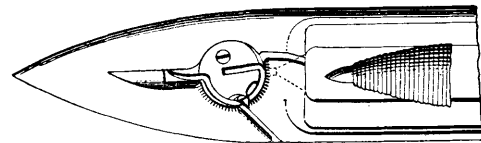

Fig. 2.

the eye. (4) It affords to the filling a tension which otherwise could not be had except by some special tension device. (Cloth woven with shuttles to which this tension is applied shows practically a perfect selvage.)

The threaders take up but small space in the delivery or eye end of the shuttles. It is not a plate on top, but is sunk below the top of the shuttle thus avoiding the chance of wearing down of the point of the shuttle and exposing the threader, a feature which is liable to cause smashes or cutting of the warp threads during weaving.

The shuttle is not weakened by the application of this threader, as the cuttings made in the shuttle in order to receive this threader are small, as are also the slots for the passage of the filling. (Jas. H. Billington Co., Philadelphia, Pa.)

AHERN'S SHUTTLE CATCH.

The same is an improvement upon the construction of that class of loom shuttles most widely used, its object being to overcome the defects of this old style of shuttle in applying the top spring and bottom catch.

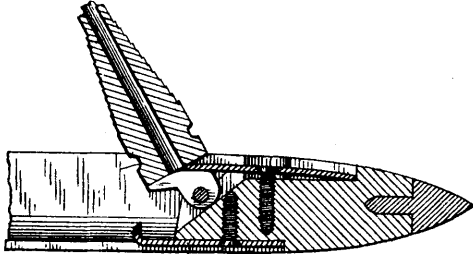

Fig. 1.

In order that the invention may be clearly understood, we will first describe the old style of shuttles, to the improvement of which the present invention relates, and this in connection with the accompanying illustrations.

Fig. 1 is a section view of the ordinary shuttle, showing the bottom catch and the top spring each

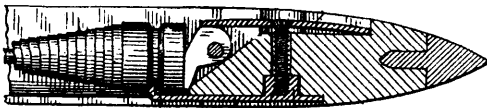

Fig. 2.

separately held in place by a simple wood screw, screwed into the wood at the end of the shuttle. These wood screws of necessity pass within a short space of one another, and are dependent for their stability upon the wood that holds the thread of the screw. Should the boring of the wood, made to receive the screw, be a trifle too large, or the constant action of raising and lowering the spindle, cause the screw to strip out of the wood, great difficulty is found in plugging up the hole made thus, or in finding a larger screw to properly re-adjust the spring and catch. The liability of the simple wood screw to work loose or to strip out of the wood is the frequent cause of "smashes," and unless the spring and catch are properly adjusted and can be kept tight, the spindle is apt to fly up and cut the warp.

Fig. 2 is a sectional view of the Aherns Patent Catch and Spring. It is a simple device to connect the top spring and bottom catch by one machine threaded screw. This screw passes through the shut-

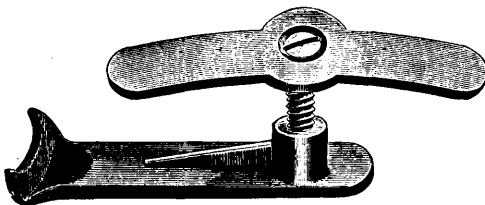

Fig. 3.

tle from the spring to the catch and screws into a lug on the catch threaded to receive it.

The advantages are obvious. There is but one screw and that a machine thread. It is easy to tighten or loosen the pressure of the spring on the spindle head. The screw is in no manner dependent upon the wood for its support, but is really a bolt passing through the shuttle. It makes the cutting out of the warp or smashes, by reason of the spindle flying up, practically impossible.

Fig. 3 shows the bottom catch and top spring connected by the machine threaded screw or bolt before being placed in shuttle, showing that it is in no way dependent for support upon the wood that surrounds it. (Jas. H. Billington Co., Philadelphia, Pa.)

SELF THREADING SHUTTLE FOR NORTHROP LOOMS.

The object is to simplify the construction of the threading device, also providing means for relieving the jar on the holder for the filling carrier when the latter is put in place in the shuttle.

Fig. 1 is a perspective view of the threading end of the shuttle, Fig. 2 a view in elevation of the threading block and Fig. 3 a perspective view of the new device for holding the filling carrier.

This latter device consists of a holder *h*, made as a block having parallel upright sides and flat parallel top and bottom faces. At its rear end this holder has a transverse shoulder *h'* formed in its top, and a lip *h²* projects from said end at the bottom to enter an extension of the recess in the shuttle body, the front end of the holder having two grooved spring jaws *h^x*, to receive the annular projections on the head of the filling carrier, which is thus engaged and held securely in position in the shuttle.

An inclined directing plate or guide *g*, assists in directing the filling carrier into position, the guide being located between the jaws and is made of re-

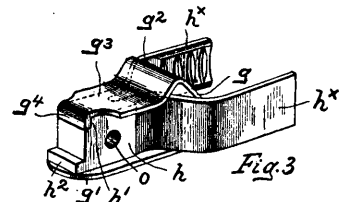
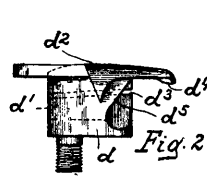
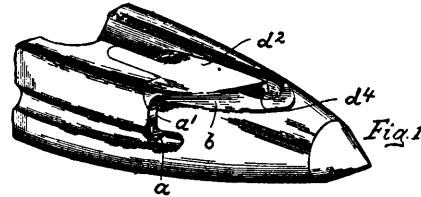

silient metal, the lower end of the guide being bent back at *g'* to extend beneath the holder *h*. The upper end of the guide is bent down at *g²*, and then rearwardly extended, as at *g³*, upon the top of the holder, a transverse down turned lip *g⁴* engaging the shoulder *h'* and positively locking the holder and guide together, the bend *g²* permitting the guide to spring or yield somewhat under impact of the filling carrier head. By this construction a single screw, passed through the holder at *o* into the walls of the shuttle body, serves to retain the holder and guide in place, doing away with a separate screw for the latter, at the same time making the spring better adapted to stand the strain of the blows as caused by change of filling carriers.

At its forward end the shuttle is provided with a new threading device, made in one block *d*, and hav-

ing a thread passage d' (see dotted lines in Fig. 2), one side of said passage being slotted at d^3 to form a thread entrance. The head of the threading block is downturned as at d^4 , an inclined horn d^5 opposite the slot d^3 guiding the thread to the side delivery eye a . A clearance space b for the thread is provided underneath the flared head d^2 , and between the downturned end d^4 and the eye a .

As the thread is drawn off the filling carrier, on the first shot of the shuttle, it passes under the end d^4 and into the thread entrance d^3 . As the shuttle returns, said thread passes beneath the head d^2 into the clearance space b , the horn d^5 guiding it to the bottom of the passage d' , from which it passes to the delivery eye a , the wall a' of the shuttle body helping to guide said thread into the eye. The tip d^4 prevents the thread from jumping out when once threaded. (Draper Co., Hopedale, Mass.)

ATTACHMENT TO C. & K. SHUTTLES.

The object is to provide an attachment to a shuttle which will operate upon exhaustion of filling to effect either the stoppage of the loom or the automatic replenishing mechanism, as the case may be.

The accompanying illustration is a top plan view of this shuttle, showing a portion of it in section.

The spindle 1, as mounted in the body 2 of the shuttle, has its head 3 held in place by the usual spring 4 and screw 5, and is provided upon its base portion near the head 3 with a "follower" 6 backed up by a spring 7. A controller 9 is pivoted to the shuttle body at 9^a in the manner which adapts the same to swing horizontally, the said controller 9 occupying a slot 9^b, which is formed in one side of the shuttle body at the end of the latter at which the shuttle spindle is pivoted. Controller 9 is backed up by a spring 10, the latter being located between one arm of the controller and the wood of the shuttle body. The controller is formed with an engaging end 9^c, which normally is caused to project outward beyond the side of the shuttle body by the action of the spring 10. The outward movement of the said engaging portion of the controller 9 is limited by means of a stop pin 11, with which the controller engages.

In applying a cop 8 to the spindle, said cop is pushed on until the follower 6 rests on the head 3, and so long as the quantity of yarn contained in the cop upon the spindle is sufficient to keep the follower 6 in the position in which it is shown in the illustration, the said follower, by its engagement with the tail of the controller 9, will retain the said controller in its retracted abnormal position. As the fill-

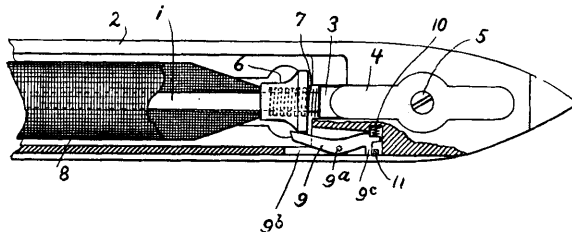

ing becomes used up and thus the base portion of the cop sufficiently unwound, the follower 6 moves lengthwise of the spindle blade, under the action of the spring 7, far enough to clear or escape from the tail of the controller 9. As soon as the follower has thus cleared or escaped from the said tail of the controller 9, the spring 10 acts to project the engaging portion 9^c of said controller into position to engage in the flight of the shuttle with the usual feeler,

and thus stop the loom or operate the filling supplying mechanism in case such is used. (Crompton & Knowles Loom Works, Worcester, Mass.)

SERGESON'S SELF THREADING SHUTTLE.

The novelty of this shuttle consists in providing a threading arrangement, whereby the shuttle is more conveniently threaded and this without liability of the yarn returning into the shuttle after having been once drawn off of the bobbin or cop. To accomplish this, a specially shaped threading eye, in connection with a suitable guide plate for the filling, is provided, said threading eye and guide plate being so

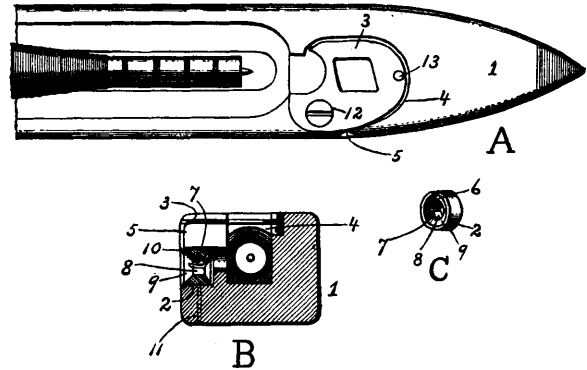

placed in the shuttle as to form a continuous passageway for the filling.

The details of the arrangement are best shown by means of the accompanying illustrations, of which Fig. A is a top view of that portion of a shuttle containing the threading mechanism, portion of the latter only being shown. Fig. B is a cross section of the shuttle through the centre of the threading arrangement, and Fig. C is an enlarged perspective view (as compared to Fig. B) of the threading eye.

Numerals of reference indicate the parts as follows: 1 indicates the body of the shuttle. Fitted into an opening in the side of said body 1 is the threading eye 2, and on the upper face of said body, above said eye, is the guide plate 3. In said body, below guide plate 3, is the channel 4, into which the filling thread is introduced after being run off from the bobbin or cop in the shuttle. In the side wall of the body 1, between said plate 3 and the upper side of the periphery of said eye 2, is the throat 5, which is in communication with the terminal of said channel 4.

In the upper wall of the eye 2, which is of substantial thickness, is the throat 6, which extends obliquely from the upper side of the periphery of said eye inwardly and is then deflected horizontally, as at 7, to the central opening 8 of said eye, thus forming a communication between the throat 5 and said central opening, which in turn opens into the outside of the shuttle. The outer face of the eye 2 is countersunk, as at 9, leaving the flat rim 10 at the periphery. The eye is secured to the shuttle by means of the screw or pin 11. The guide plate 3 is secured to the shuttle by means of the screw 12 and the tension post 13, said post rising from the interior of the shuttle and being connected with the guide plate 3. The shuttle is threaded by having the filling pass, from the bobbin or cop as the case may be, under the plate 3 and around the post 13, through the channel 4 until it reaches the throat 5, when it descends the latter and enters the throat 6, and traversing the latter is passed into the eye 2, and from

there out of the shuttle. It will be noticed, that should the portion of the filling outside of the eye run around said eye, the countersink 9, assisted by the obliquely extending throat 6, will keep said portion of filling at the periphery of the eye, especially on the rim 10, and so prevent it from reëntering the throat 6, and hence it cannot return through said throat, the throat 5, and the channel 4 to the bobbin or cop, but, on the contrary, retains its proper position in the eye 2 of the shuttle, so that the filling will be properly run off without liability of tangling with the bobbin. (R. Sergeson & Co., Philadelphia, Pa.)

SERGESON'S LOCKING DEVICE FOR SHUTTLES.

The object is to provide a locking device for the spindle for holding the same securely either in its raised or lowered position.

The illustration is a longitudinal sectional view of a portion of a shuttle, clearly showing this locking device.

Examining the illustration, we find that the head C of the spindle B, has on its under side a heel D and open slot A, through which is passed a pin E. The rear of said spindle head C is provided with a recess I, adapted to receive the bearing piece F, which is kept pressed against the head C by spring G.

In order to securely hold the bobbin on the spindle, clamps H are provided, adapted to engage the bobbin head, the ends of the shanks of said clamps being connected by a transversely extending plate J, which prevents said shanks from closing on each other when the bobbin is removed from the spindle. The tendency of the spring G is to press upwardly against the back of the spindle head C, and thus throw down the spindle B, so that said head is loose on the pin E, and thus is liable to be lifted and displaced while the spindle is improperly located. To prevent this, a crossbar K is provided, and which is connected with said head by means of a screw or pin L, whereby said crossbar may be turned so as to extend parallel with said head or in the position at a right angle thereto, it being noticed that the portion of the body of the shuttle at the adjacent sides of the channel or opening occupied by the head C has offsets or shoulders M thereon, on which the ends of the crossbar K are adapted to bear, and whereby the spindle B is restrained from being lowered when in operative position, thus positively preventing disconnection of the spindle from the pin E.

Should it be desired to remove the spindle, the crossbar K is simply given a quarter turn, whereby it clears the offsets or shoulders M and occupies a position parallel with the head C. Now the spindle

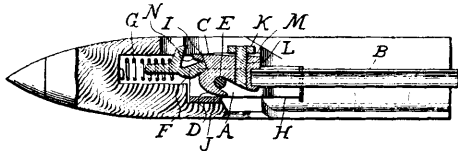

is thrown down by the action of the spring G, and the back of the head C rises, when the head can be raised by hand clear of said pin and so removed therefrom, thus permitting ready removal of the spindle from the shuttle.

In order to replace the spindle, the head C is reapplied from the under side thereof, the slot A being in somewhat vertical position, so as to pass over the pin E, after which said head is lowered on said pin, and the spring G and bearing piece F are applied in position so as to bear against the head when the spin-

dle is lowered. The crossbar is again turned at a right angle to the head C, so that its ends overhang the shoulders M, thus preventing the disconnection of the head from said pin, while, however, allowing the proper motions of the spindle with the bobbin thereon.

The upper wall of the recess I, is extended in the direction toward the bearing piece F, so as to form the tongue N, and in replacing the spindle head in position as before stated, the adjacent limb of the piece F enters the recess I, so that when the spindle is raised, said tongue freely overhangs said limb and places the piece in its normal position, said piece N and head forming a knuckle, which causes the piece to yield in the subsequent out and in motions of the spindle, while the tongue prevents upward disconnection of the piece, the pressure of the piece being directed on the head. (R. Sergeson & Co., Philadelphia, Pa.)

DUDLEY'S SHUTTLE.

The object is to so construct the base of the spindle and its co-operating parts that the cop can be placed snug against the base of the spindle, thus giving a firm support to the cop.

The illustration is a side view of a shuttle, partly in section, showing the spindle in its raised position.

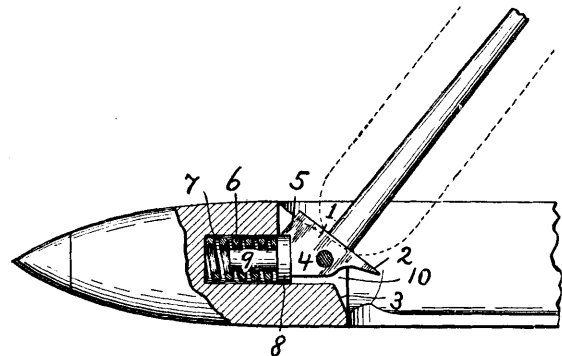

The base 1 of the spindle has a downwardly-extending toe 2, which, when the spindle is closed, bears against a shoulder 3 of the shuttle body. The heel 4 of the spindle forms a rectangular point, and is provided with a shoulder 5. A spring 6 is placed in the cylindrical cavity 7 of the shuttle, and a disk 8, provided with a stud 9, bears on the coiled spring 6. When the spindle is in its closed position, the spring 6 forces the disk 8 against the face 10 of the heel 4, and thus securely holds the spindle closed. The spindle in turn is held in its raised position by the disk 8 bearing against the shoulder 5, as is shown in the illustration. (S. A. Dudley, Taunton, Mass.)

TENSION DEVICE FOR AUTOMATIC LOOM SHUTTLES.

The object is to provide an automatic threading tension device to loom shuttles, by means of which the delivery of filling at the first throw of the shuttle and at each subsequent throw is controlled by frictional resistance.

Fig. A is a longitudinal sectional view of part of the shuttle, showing, in solid lines, the filling-end extending from the bobbin through the tension device, and indicating in broken lines the position of the filling-end as it enters the spiral of the tension device. Fig. B is a transverse sectional view of the shuttle, showing the spiral guide of the tension device, and Fig. C is a perspective view of the latter.

The new tension device consists of a wire rod *o*, the forward end 1 of which is bent and doubled on itself, and then wound to form the spiral 2, the plane of which is at right angles to the axis of the rod *o*, the spiral being sufficiently open to allow the passage of the filling end. After bending the wire to form two turns, the same is bent into larger curve 3, forming the guide to the entrance 4, and then bent sharply to form the end 5, which is secured in the side of the shuttle, while the wire rod *o* is secured to the head of the shuttle by means of the clamp plates 6.

In mounting the device in the shuttle the end 1 is placed on a line with the axis of the bobbin, forward of, but near the end of the bobbin, so that the filling end as it is drawn from the end of the bobbin passes in the shape of a cone to the opening in the spiral, the said opening forming the apex of a cone, of which the end of the bobbin forms the base. By this arrangement the filling end is drawn against and around the end of the bobbin in frictional contact with the thread on the full fresh bobbin, and when part of the thread has been delivered, the filling end is delivered while in frictional contact with the exposed end of the bobbin. By placing the end 1 near the end of the bobbin, ballooning of the filling end,

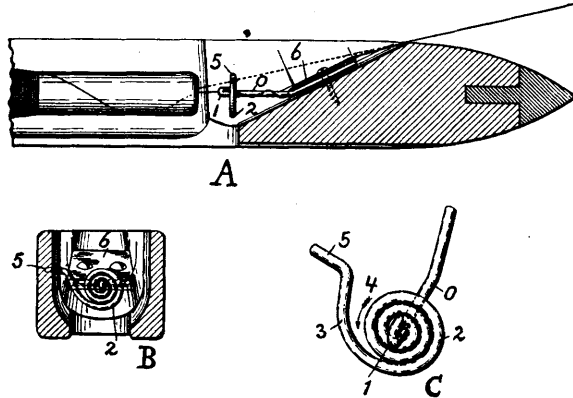

which is the main cause of the kinking of the filling in weaving finer qualities of cloth, is prevented.

On the first throw of the shuttle, the filling end will pass around the end of the shuttle and be guided into the entrance 4, and around the two turns of the spiral 2, at the same time winding spirally around the wire rod *o*, and thus immediately controlled by the frictional resistance of the thread on the bobbin and on the wire rod *o*. (Joseph E. Tichon, New Bedford, Mass.)

SHUTTLE FOR NARROW WARE LOOMS.

Heretofore the length of the bobbin as used in connection with these shuttles has been limited on account of the unsatisfactory angle of pull on the

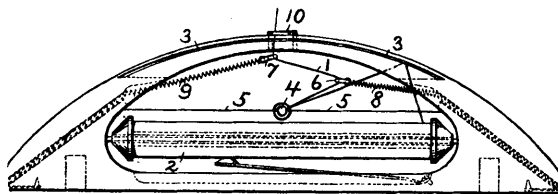

thread in unwinding from large bobbins. To overcome this disadvantage is the object of this shuttle, which is shown in its top plan view in the accom-

panying illustration, clearly showing the new method of unwinding the thread from the bobbin.

The thread 1, as coming from the bobbin 2, passes up through an arched guideway 3, down to the guide eye 4, as supported yieldingly by suspension cords 5, then through the right and left tension eyes 6 and 7, secured respectively on the ends of the springs 8 and 9, and out of the shuttle through drawing off eye 10.

It will be seen that by means of the arched guideway 3, the angle, as formed by the thread unwinding from the bobbin, is kept constantly uniformly short (as near 90° as possible), since the thread travels in said arched guideway, and thus constantly changes its point of angle of pull conforming to the respective position of its point of unwinding on the bobbin. (Schaum & Uhlinger, Phila., Pa.)

HEDDLES, HARNESSSES, REEDS AND TEMPLES.

FEHR'S FLAT STEEL HEDDLE.

This heddle is especially adapted for weaving cotton and silk fabrics, and is made out of one piece of cast steel, which construction prevents the warp threads from catching in the eye, since the eye is one solid piece of cast steel, and is not filled out with solder. A view of the heddle is given in the accompanying illustration, which shows very clearly its construction. The heddle is very thin and the holes at each end, by which it is supported in the harness frame, together with the eye of the heddle, are made by swageing.

Owing to its smoothness, and being perfectly flat, the heddle offers almost no friction to the warp threads, said heddle turning only enough to allow the thread to pass through the eye. In connection with cotton fabrics as high as 40 heddles per inch per shaft may be used, whereas in connection with weaving silks, as high as 60 heddles per inch per shaft can be used.

Owing to the peculiar style of construction of this heddle, the same can be quickly transferred and counted off. Unlike other wire heddles, which come in bunches, these heddles, for the sake of convenience for handling in the mill, are threaded on rods previous to shipping. (Steel Heddle Manufacturing Co., Philadelphia, Pa.)

THE "HOWARD" TWIN STEEL WIRE HEDDLE.

These heddles are specially designed for use in connection with fine, high textured textiles, and are also known as German heddles, for the fact that originally they were introduced in this country from Germany, the home of high textured fabrics. These German heddles at once met with such favor in this country, in place of the domestic heddles, that the Howard Bros. Mfg. Company at once grasped the idea not only to improve upon their construction, but at the same time manufacture them on a more economical basis, by machinery complete, as compared to the German method of partial hand work, in turn producing a more uniform and reliable article.

The accompanying illustration shows this German or Twin tempered steel wire heddle in two positions, Diagram A showing the heddle in its position when on the Harness frame, *i. e.* with its open thread eye towards the fell of the cloth. Diagram B shows this

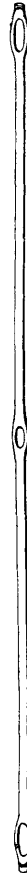

heddle turned 45°, and being more particularly given to assist in describing the construction of this heddle, which is made of two parallel wires *a, b*, tinned or soldered together. The thread eye *c* is formed by then separating said wires, the end eyes *d* and *e*, as required for the heddle bar or rod (not shown) to pass through, being formed by throwing the ends of the wire back on the main wires, and twisting, as at *d'* and *e'*. After thus producing the heddle on one machine, they in turn are taken to another machine for soldering the eyes after they are twisted, in order that the heddle presents a perfectly smooth surface throughout, without any possible chance for catching or chafing the warp threads; permitting their use in connection with the most delicate, high textured, cotton, woolen, worsted and silk fabrics. (Howard Bros. Mfg. Co., Worcester, Mass.)

METAL DOUP HEDDLE.

The doup needle in this heddle as carrying the whip thread, is connected or pivoted to the heddle strips in such manner as to be tilted toward one or the other heddle strip by their alternate operation, being thereby caused to pass alternately on one side or the other of the standard warp thread or threads extending between the heddle strips.

Of the accompanying illustrations, Fig. A is a front view of the attachment, and Figs. B and C front views of a portion of the attachment when the same is lifted to throw the whip thread to one side

A description of the construction and operation of the heddle is best given by quoting numerals of reference accompanying said illustrations, and of which 1 and 2 indicate the heddle strips, 3 the doup needle, pivoted at its lower end to both heddle strips, and 4 is a connecting device, joining the two heddle strips and holding them a definite distance apart while permitting them to have independent vertical movements. 5 and 6 are weights secured, respectively, to the lower ends of the heddle strips 1 and 2, which weights however if desired may be dispensed with. 7 and 8 are the cords attached, respectively, to heddle strips 1 and 2 and leading to the jacquard machine or harness frame of the loom. 9 represents the standard warp thread or threads, as the case may be, extending between the heddle strips 1 and 2. 10 represents the whip thread, extending through the eye of the needle 3. 11 and 12 are thread guides projecting inwardly toward each other from the heddle strips 1 and 2 respectively.

The operation of the heddle is thus: Assuming the device to be in its lowered position, as shown by means of Figs. 1 and 2, the lifting of cord 8 lifts the whole attachment, comprising both heddle strips and the needle. Initially, however, the strip 2 lifts a short distance independently of strip 1, causing the needle to be thrown to the left, as shown in Fig. B, and as the whole device is lifted, the whip thread 10 passes to the left of the standard warp thread or threads 9; guide 11 keeping the standard warp thread or threads from catching between strip 1 and needle 3.

The respective pick of filling is then inserted, the tension upon cord 8 released, and when in turn by gravity, the device descends to its original position.

For producing the next pick (twist) the cord 7 is lifted, which first throws the needle 3 to the right, *i. e.* against strip 2, and then lifts the whole device, causing this time the whip thread 10 to pass to the right of the standard warp thread or threads, in order to produce the required twist effect in the fabric, the procedure itself being readily understood by means of consulting Fig. C.

Of the accompanying diagrams of woven leno fabrics, Fig. D shows such a one as produced by means of one whip thread 10, working against six standard or ground warp threads 9. Diagram E shows the use of two sets of doups *a* and *b* respectively, one whip

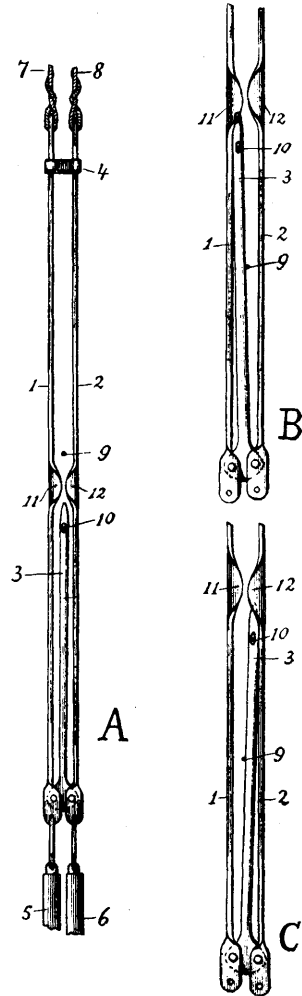
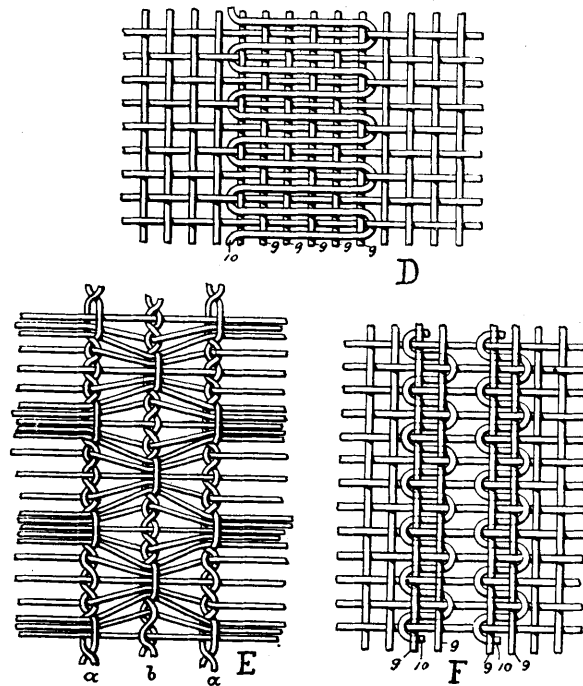

or the other, respectively, of the standard warp thread or threads.

thread working against one standard warp thread in either instance, each attachment (*i. e.* doup) being operated upon independently from the other. Diagram Fig. F shows the formation of a centre selvage as can be readily produced by means of the new heddle, one whip thread working in this instance against two standard threads. (Horace H. Sutcliffe, Frankford, Pa.)

STRENGTHENING DEVICE FOR REEDS.

The object is to strengthen the reed at its ends, the mode of construction being clearly shown by means of the accompanying illustrations, of which Fig. 1 is a section of a reed, showing one of the reed strips grooved for the reception of a wire, and Fig. 2 is an end elevation showing the mode of fastening this wire to caps.

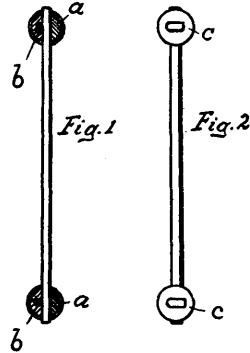

One of the strips *a* of the reed bar is formed with a groove, for the reception of the wire *b*, and which projects beyond the ends of the reed bars and extends through a cap *c* put over the ends of said reed bars. Each wire is then bent over and soldered to the caps. (The Luther Reed Manufacturing Co., Fall River, Mass.)

CAP FOR LOOM REEDS.

The novelty consists in providing means for holding the heading bar of the reed more securely in place; thus strengthening the union thereof to the reed ribs.

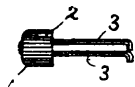

This feature is accomplished by means of an attachment to the reed as shown in the accompanying illustration, the affair in question being a cap and two holding staples. One of these attachments is used each on the top and on the bottom at either end of the reed.

For adjusting this attachment to the reed, the heading bar of the reed is cross grooved to provide therein a slot or recess, while the cap 1 is similarly provided with a groove 2 and is fitted over the heading bar with its open end on the reed rib end, its slotted portion admitting the neck or reduced part of the heading bar and its body part in the recess previously referred to. When the cap is thus put on, its outer end is to be substantially flush with the outer edge of the heading bar, and when through suitable openings in the end face of the cap are put the staples 3, whereby the cap is secured firmly to the end of the reed ribs by embedding said staples 3 in a body of pitch and rosin placed in the hollow chamber of the reed rib and allowed to harden about the staples. For securing these staples 3 more positive in place, the same are turned at the ends for engagement with the cement to thus better hold against withdrawal. Instead of the cement being employed, a pointed staple may be used and driven into the end of the reed rib; but the use of cement is preferred, as it gives a firmer hold, besides permitting of being heated to allow withdrawal of the staple at times for purposes of repairing the reed, and, too, it adds solidity and strength to the whole connection for resisting strain and consequently displacement, while arrangement of the caps in grooves of the heading bar for engage-

ment therewith prevents the ribs of the reed from drawing apart. (Luther C. Baldwin, Providence, R. I.)

LACKEY'S HARNESS FRAME AND HEDDLE.

The objects are to provide plenty of room for the heddles to move in, at the same time preventing the warp threads from catching.

Fig. 1 shows part of one of these heddles, and Fig. 2 portion of the harness frame.

The harness frame is composed of a top and bottom piece, alike in construction (the top piece *A* only being shown), and side pieces *B* (only the upper portion of the left hand side piece being shown). The heddles *C* are made of flattened wire, having warp eye *a*, and at each end an open slot *b*, which conforms with the supporting rail *c*, having a web *d*, fitted to a recess in the edge of the cross piece *A*, the rail *c* having a T-shaped extension *e*. The side walls *B* of the frame are composed of two metal strips, leaving a space between, and into which is fitted strip *g*.

When it is desired to fill the frame with heddles, the strip *g* is removed, thus exposing the T end of the rail *c*, when the heddles can be easily put on or removed as the case requires. (Lackey, Hopkins & Perkins Co., Philadelphia, Pa.)

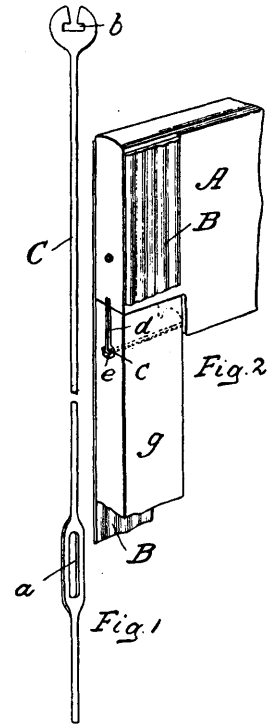

REED AND REED MOTION FOR SPECIALTIES.

The object is to provide means whereby the warp threads extend in curves in the plane of the fabric, in this manner producing novel effects to the cloth.

Fig. 1 shows the construction of the reed and the method of mounting the same in the loom. Fig. 2 shows one of the effects produced in the fabric, the nature of which, to a certain extent, can be varied.

Examining illustration, Fig. 1, we find that the dents of the reed are arranged in sets, indicated respectively by numerals 1 and 2, said dents extending at varying distances from each other, *i. e.*, the dents of one set diverge at the top and converge at the

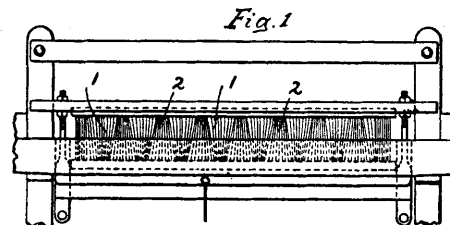

bottom, while the dents of the next set are arranged in the opposite way.

A vertical motion is imparted during weaving to this reed, in this manner diverging the respective sets of warp threads (more or less) towards or away from each other, thus producing the required effect

to the fabric. On the backward movement of the lay, the reed is every time raised to its highest position in order to permit the shuttle to pass freely through the shed. On the forward beat of the lay, in turn, the reed is lowered, according to the pattern

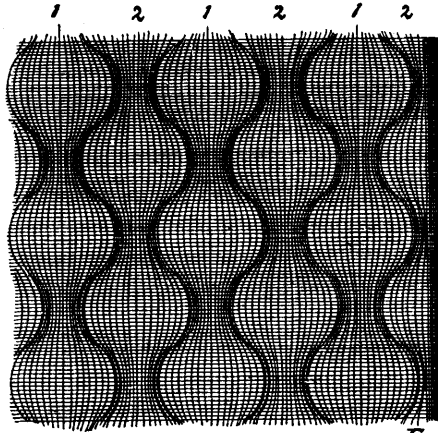

Fig. 2

required, to regulate the proper position of the warp threads, in order to produce the curved lines previously referred to, as shown in Fig. 2, for the sake of one example.

The mechanism for raising and lowering the reed as required by the effect in the cloth, is controlled by indications on the pattern chain. (Crompton & Knowles Loom Works, Worcester, Mass.)

FEHR'S HEDDLE FRAME.

This frame is characterized by the manner in which the heddle bars are secured in said frame, and which allows them to be easily taken off so as to add or take away the required number of heddles when making up a set of harnesses for a new structure of cloth.

The construction of this frame, *i. e.* the attachment of the heddle bars to the side frames is shown in the accompanying illustrations, of which Fig. 1 is a portion of a side vertical frame, as used in connection with a similar frame (on the other side) to connect the two horizontal wooden (top and bottom) pieces of the heddle frame, the portion shown including a portion of the strap, shaped for receiving one of said horizontal frame pieces and the grooves for the attachment of one

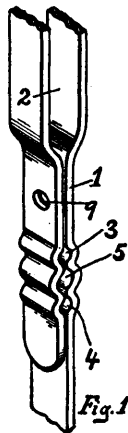

Fig. 1



Fig. 2

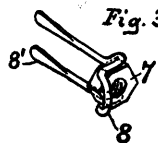

Fig. 3

end of a heddle bar. Fig. 2 is a hook, having one end threaded, which is secured in the vertical frame por-

tion and holds one end of the heddle bar. Fig. 3 is a nut with a fastening device shown in connection with it.

Referring to the illustrations, 1 indicates a portion of one of the vertical frames, which is bent so as to form a loop 2 for inserting one end of the horizontal pieces, the former being bent to form two small holes 3 and 4 and a larger hole 5 between them. The threaded end of the hook 6 is inserted into the hole 5 and the nut 7 fastens it, said nut being prevented from unscrewing after having been set properly, by means of a bent wire piece 8, whose ends form two shanks 8', which fit into the holes 3 and 4 respectively, on the vertical frame piece 1, the ends extending past the frame being bent back over opposite sides of said frame piece, which prevents any longitudinal movement of the hook 6. The sides of the holes 3, 4 and 5 are clamped together by means of a screw fitting into the hole 9 which also clamps the loop of the vertical frame piece onto its respective horizontal piece. (Steel Heddle Manufacturing Co., Philadelphia, Pa.)

THREAD CUTTING ATTACHMENT TO DRAPER TEMPLES.

The object is to provide means by which the filling thread of the discharged filling carrier is engaged (for the purpose of severing) with greater facility and accuracy than heretofore.

The illustration is a side elevation of a temple provided with the new thread cutting device, part of the cap and pod being shown broken away in order to show the cutting arrangement.

The pod 1 of the temple is slotted at 2, to receive an upright steel blade 3, secured by stud 4 in the

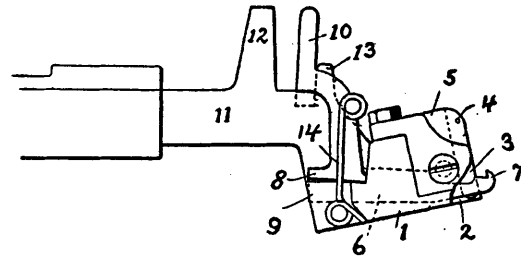

cap 5. In slot 2 is also placed a bar 6, bifurcated at its inner end to straddle the blade 3, said bifurcated end being formed as an upturned hook 7, projecting beyond the face of the pod 1. The outer end of bar 6 has a laterally extended shoe 8, which slides on the ear 9 of the pod, and is upturned to form a heel 10, which in turn slides on the top of the temple shank 11, between an abutment 12 and a lug 13. Spring 14 maintains the heel 10 in normal position.

The operation of the cutting device is thus: When the lay beats up, the hook 7 is brought into position beneath the filling thread, said thread being caught and held by the upturned hook 7. As the lay continues its forward movement, an actuator as fast on the lay (not shown) engages with the heel 10, moving the same forward against the action of spring 14, the hook 7 in turn drawing the thread across the blade 3 and severing it.

The spring 14 gives a yielding movement to the heel 10 when actuated, so that it is not brought up with a heavy shock against the abutment 12 as the lay completes its forward movement. (Draper Co., Hopedale, Mass.)

JACQUARDS, CARD STAMPING AND LACING MACHINERY.

THE C. & K. JACQUARD FOR TWO WEAVE FABRICS.

In these Jacquard machines two cylinders are employed for coöperation with the needles, one of the cylinders carrying the pattern for the border and the other carrying the pattern for the body of the goods.

The gist of the improvement consists in devices to bring automatically the respective cylinders into action, alternately, at the required times.

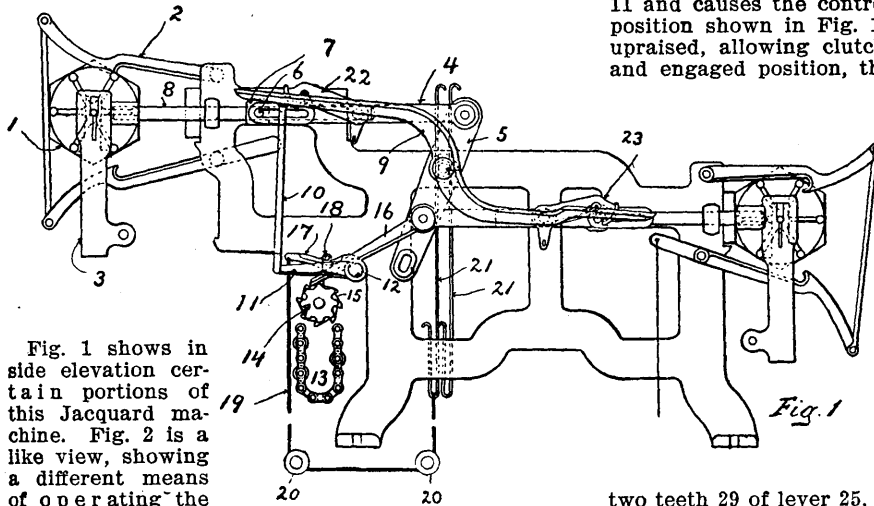

Fig. 1 shows in side elevation certain portions of this Jacquard machine. Fig. 2 is a like view, showing a different means of operating the pattern lever.

The mechanism is shown in connection with a double action Jacquard machine, where also two sets of griff blades are used; however, said mechanism may also be used with single lift Jacquards. (For a general idea as to the operation of these machines,

the shoulder of its slot comes against the pin 6, it acts to force the left hand carrier into the position shown in Fig. 1, and remains in this position so long as it remains unclutched from its actuator.

The controlling lever 9 is connected by a rod 10 with the pattern lever 11 as hung on stud 12, the said lever being acted upon by a pattern chain 13 passing around a pattern barrel 14 and having connected therewith a ratchet 15. The pattern chain 13 is advanced by means of pawl 16 pivoted to one end of rocker 5. In connection with pawl 16 a pawl lifter 17 is employed, on which bears a pin 18. A cord 19 has one end connected with pawl lifter 17, and extends around pulleys 20, the other end being connected with one of the hooks 21 of the Jacquard machine. A ball on the pattern chain raises the pattern lever 11 and causes the controlling lever 9 to assume the position shown in Fig. 1, thereby holding clutch 22 upraised, allowing clutch 23 to occupy its lowered and engaged position, the clutch remaining in such position until locked to permit the other card cylinder to operate.

In the mechanism shown in Fig. 2, numeral 24 indicates a locking arm, by means of which the arm 25 is held in either of its extreme positions until a shift thereof is required to be made. This arm 25, when raised, operates through a wire 26 to raise the controlling lever. The locking lever 24 is pivoted on pin 27, and has a toe 28 engaging with

two teeth 29 of lever 25, the said toe 28 engaging the teeth 29 alternately to hold the lever 25 in its two extreme positions. For the purpose of operating the locking lever 24 automatically, when desired to disengage it from the lever 25 to permit the position of the same to be altered in order to operate the other card cylinder, the said locking lever 24 has connected thereto the cord 30, extending around pulleys 31 and connected with the hooks of the Jacquard.

It will be seen that in this case the pattern chain (13 in Fig. 1) is dispensed with, the lever 25 being moved (when required) alternately by the engagement of the teeth 29 with the toe 28 of lever 24.

(Crompton & Knowles Loom Works, Worcester, Mass.)

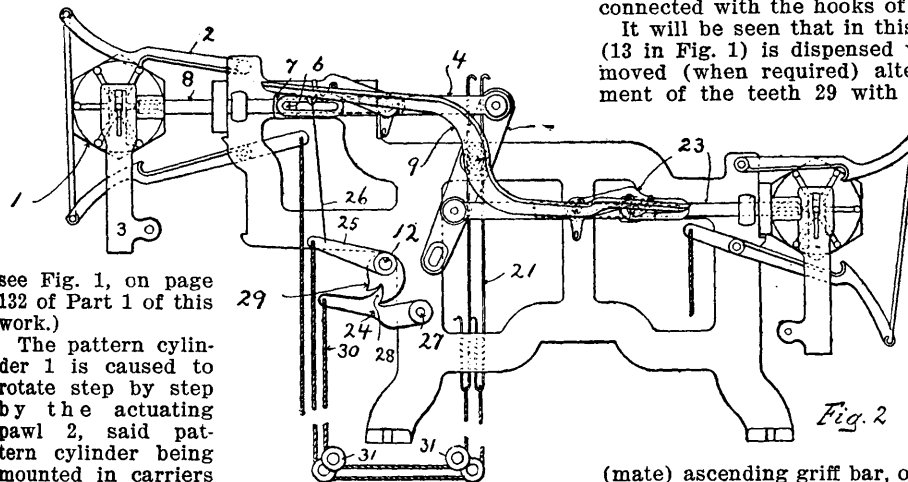

see Fig. 1, on page 132 of Part 1 of this work.)

The pattern cylinder 1 is caused to rotate step by step by the actuating pawl 2, said pattern cylinder being mounted in carriers 3. With these carriers 3 is combined a mechanism consisting of clutch devices or actuators 4, connected to rocker arm 5, and being supported by pins 6, projecting from collars 7 fast on slide rods 8. During the outward movement of the actuator, if

HOOK GUIDE FOR C. & K. OPEN SHED DOUBLE ACTING JACQUARDS.

The object of this guide (one for each hook) is to prevent the respective crook of a descending hook from catching with its

(mate) ascending griff bar, obviating the necessity of an extra beat of the card cylinder for obtaining the same result, which feature in turn would reduce the speed of the machine.

Fig. 1 is a vertical section of portions of an open shed, double acting Jacquard machine, showing this guide applied to the hooks.

1 indicates the bottom board, 2 the card cylinder, 3 the needles, and 4 the hooks, each one provided, respectively, with the three crooks 4' and 4". 5 indicates the bars of one of the two movable griffs,

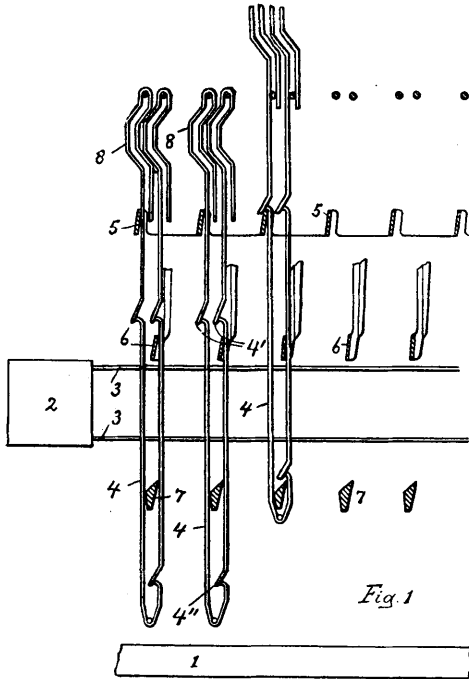

shown raised, and 6 the bars of the other movable griff, shown in its lowered position. 7 indicates the bars of the stationary griff.

The hooks 4, as engaged, respectively, either by griff bars 5 or 6, are bent at their upper end to form a cam or guide 8 which serves as a switch to guide the nooks, so that when a hook, by the weave, has to descend, its free crook will not come in contact with the (mate) rising griff bar; the guide 8 thus preventing any liabilities of mispicks.

The hooks 4 thus referred to, and made of one piece of wire, can, with advantage, be made in two parts, as is shown by referring to Figs. 2 and 3, of which Fig. 2 shows the lower limbs of the two hooks as united by means of the neck cord to act in unison, Fig. 3 being a detail view of said ends fitted together and united by its neck cord.

Each limb of the two hooks as thus united by the neck cord is formed of a piece of wire, the

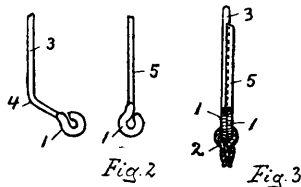

lower end being bent into an eye 1, the neck cord 2 being adjusted to both hooks, *i. e.*, to the two eyes 1. The lower limbs of one of the hooks 3 are bent, as at 4, in order that when in position for use the eyes 1 may be brought into apposition with each other, so that the corresponding neck cord may be passed through both eyes 1, as is clearly shown in Fig. 2. The lower limb 5 of the other hook is straight. Thus it will be seen that the two hooks act in unison, as if made from one piece of wire, as done heretofore. In order that the eyes may fit closely together, they are flattened transversely, as is shown in Fig. 2.

This construction of a double hook made in two pieces has the advantage of being cheaper to manufacture; again, if one section breaks or is rendered useless for perfect work, only this section needs to be replaced. (Crompton & Knowles Loom Works, Worcester, Mass.)

HOOK FOR C. & K. JACQUARD MACHINES.

The object of the construction of this hook is to reduce the friction between the hooks and their guide plate, and also to require less power on the part of the needles, as actuated upon by the Jacquard card, to press the hooks away from the knives of the griffe, and thus prevent the liability of holes being punched in the cards by the needles, due to excessive resistance of the hooks.

The details of the construction of the hook are best shown by means of the accompanying illustration, which is a side view of a hook, shown in connection with a cross section of its griffe knife and a cross section through a portion of its guide plate.

Referring to the illustration, 1 indicates the hook which is of the usual construction, except that its crook portion 2 has its projecting end 3 bent backwardly toward the main part of the hook 1, and then bent upwardly, the end of which is parallel with the main part of said hook 1 to form an attaching end for a confining band 4. One end of the confining band 4 is secured upon this free end of the hook 3, the other end being left open, to loosely hold the main part of the hook 1, and allow said hook to move freely in it, as shown in dotted lines.

By thus placing the confining band 4 above the lift bar 5, the former cannot come into contact with said lift bar, and thus friction and wear are prevented, but which otherwise is the case, provided the confining ring is placed below the lift bar 5 as previously has been done. By leaving the confining band open, so that the main part of the hook 1 can move freely in it, movement is given more easily to it, since the bottom end is used as a pivot for the movement, instead of the confining band, in case the main part of the hook was secured also to said confining band as was formerly the case.

Instead of having the confining band secured to the end 3 of the hook, it may be secured to the main part of the hook with the said end 3 free to move in the open confining band 4. (Crompton & Knowles Loom Works, Worcester, Mass.)

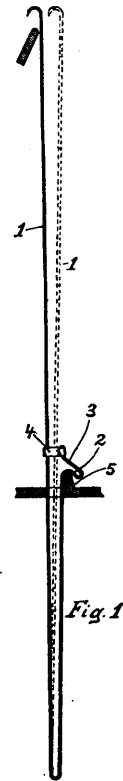

THE VERDOL JACQUARD MACHINE.

This machine is distinguished from the regular Jacquard machine principally in the manner in which the hooks of the machine are actuated to produce the desired pattern, that is, a continuous sheet of perforated paper with the pattern stamped out on it, is used instead of a set of separate cards laced together, which condition, of course, requires the use of other methods of actuating the hooks of the machine from that employed for the regular Jacquard, and for which reason a description of the construction and operation of this machine will be of interest.

The sheet of paper used for the pattern is thinner than regular Jacquard cards, being reinforced for about one-half inch on each edge of the sheet, which is the portion subject to the most wear during weaving. The machines are all fine index, and are made in different styles, single lift, double lift, rise and fall, etc., being suitable for all kinds of fabrics from coarse damasks to fine upholstery goods.

Two sets of needles are employed, one set working the other set, which in turn actuates the hooks of the machine, so that they may be operated upon by the knife box (griffe). The first set of needles stand vertically, being made of very fine steel wire, and have a loop made in the proper portion of their length, through each of which a corresponding needle from the other set of needles, as placed horizontally, is passed, so that the first set of needles has only to be actuated very slightly in order to raise or lower the ends of the push wire which is connected with the horizontal needles, passing through the loops of the needles thus actuated, sufficiently to have said horizontal needles actuated by the front edge plates on the machine and thus in turn allow the hooks to escape the movement of the knife box. The pressure required to raise the vertical needles is very slight, which thus allows the paper, on which the pattern is stamped out, to be made comparatively thin, since it receives practically no wear from pressing the needles. The paper has peg holes punched out on each edge, there being three holes along the edges of what corresponds to each card, so that in case one set of holes becomes worn, by simply moving a screw on the cylinder carrying the pegs, one of the two remaining sets of holes can be used, and the sheet presented to the needles as previously done with the first set of holes.

The construction and operation of the machine is best explained by means of the accompanying illustration, which is a perspective view of the machine, showing particularly the arrangement of the mechanism for feeding the perforated pattern sheet for actuating the needles of the machine.

The pattern sheet is run on the curved plate, shown under the front edge plate, said curved plate being perforated in that portion which is situated directly under the lower ends of the vertical needles, there being a corresponding hole for each needle. The pattern sheet is moved forward by two pegged wheels, one for each edge, the pegs entering the holes in the sheet, and as said wheels receive an intermittent rotation, the pattern wheel is taken forward intermittently. As each portion of the sheet, corresponding to a regular Jacquard card, comes over the perforated portion of the plate, its motion is stopped for a short space of time, and the plate is moved slightly upwardly, thus pressing the sheet against the lower ends of the needles and raising them, except where holes are punched in the sheet, in which instance the corresponding needles pass through them and are not raised. The needles thus raised, in turn raise the ends of the horizontal needles passing through their loops, and the ends of these slightly raised needles are then in direct line with the solid portions of the front edge plate, which is now given an inward motion and thus pushes the push wires, which in turn push the needles in their path, inwardly. The needles thus pushed inwardly, in turn push their corresponding hooks away from the bars of the knife box, and consequently said hooks are not raised, in other words, a hole in the sheet indicates that the proper hook will be raised, and a blank means that the hook will not be raised.

The horizontal needles which were not raised by their corresponding vertical needles, as explained, are not acted upon by the front edge plate, but as

the said plate moves forward, these needles pass in the open slots of the plate especially made for this purpose.

The Verdol machine offers the advantage that the fabric can be woven in the loom, either face up or face down, with the one set of cards, by simply reversing the front edge plate, and when consequently a hole in the sheet will then indicate that the proper hook of the machine will not be raised, a blank in the sheet indicating the reverse effect to a respective hook. Hooks and needles in

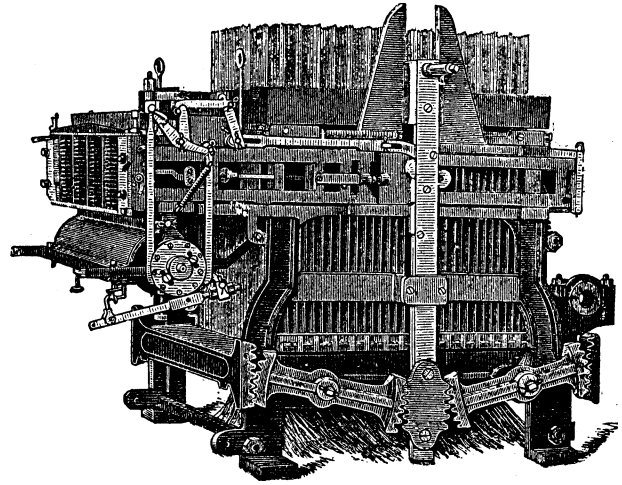

this Jacquard machine can be readily changed when so required for one reason or the other.

The cylinder carrying the pattern sheet makes $\frac{1}{2}$ of a revolution for every pick, said motion being obtained from the vertical pawl shown connected to suitable mechanism.

Among the advantages claimed for the machine are the economy in the price of card pattern material, no lacing of cards, as well as less space required for the cards on the machine as well as when stored. This machine, although new here, has been successfully introduced for some time all over Europe. (Verdol Jacquard Machine & Card Cutting Co., Paterson, N. J.)

ROYLE'S PUNCH HEAD FOR CARD STAMPERS.

The object of the new arrangement is to relieve the strain upon the hand of the operator in manipulating the punch keys.

Fig. 1 is a view in front elevation of the punch head, and Fig. 2 is a view of the same in its top plan.

The punch head is denoted by *a*, the rods for raising and lowering it by *b*, *c*, and the gang of punches by *d*. The keys on the front of the head, which are intended to control the punches for punching the peg and lace holes in the card, are denoted by *e*, *f*, *g*, *h*, *i*, and those on the opposite side of the punch head for controlling the punches for punching the pattern holes in the card are denoted as a whole by *k*.

In order to bring the punch keys on the front of the head, which, as previously stated, control the punches for punching the peg and lace holes in the card, within convenient reach of the operator while the fingers of the hand are manipulating the keys *k* on the opposite side of the punch head, a lateral extension *l* is provided, being fixed to the end of the middle key *g*, and its free end carried into such posi-

tion with relation to the two keys *h* and *i* to the right of it—for example, to the position *m*—that the thumb

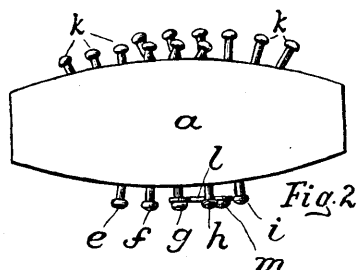
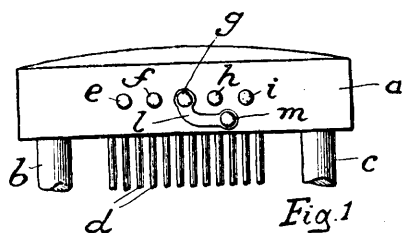

of the right hand of the operator may cover at the same time the two keys *h*, *i* and the end *m* of the extension which controls the third key *g*, while the thumb of the left hand of the operator readily controls the other two keys *e* and *f* at the left of the centre. This enables the right hand of the operator to be thrown over into the natural position on the head to permit the free operation of the fingers of the hand in manipulating the keys *k* at the back, and the strain heretofore caused—and which has had a tendency to distort the hand of the operator by daily manipulation of the keys—is avoided, in turn materially lessening the wear upon the muscles and nerves of the operator. (John Royle & Sons, Paterson, N. J.)

ROYLE'S CARD LACING MACHINE.

In connection with this machine, the cards are fed to the lacing mechanism by hand; a variable reciprocatory movement of the lacing needles being arranged to coact with the variable feed of the cards, to account for the difference in the length of stitches required in lacing said cards. The construction and arrangement of the shuttles is such as to permit free access to the same, and the cards to be laced are so positioned on the machine as to be easily and accurately conveyed by the operator to the feeding mechanism.

The illustration is a right-hand side elevation of the machine, clearly showing the operation of the same.

The cards are fed step by step to the stitching mechanism by a pair of endless chains—one on each side of the machine, only one *C* being visible—provided with pegs *c*, adapted to enter the peg holes in the cards. These two chains are mounted upon sprocket wheels *c*¹, arranged in pairs at or near the opposite ends of the machine and actuated by a pawl *c*², carried by a rocking arm *c*³, connected by a rod *c*⁴ with a vibrating lever *c*⁵ in position to be engaged by a cam disk *c*⁶, operated from the driving shaft *R*. The vibrating lever *c*⁵ is operated in a direction opposite that in which its cam *c*⁶ operates it by a spring *c*⁷, fixed at one end to the lever and at the opposite end to the frame of the machine. The sprocket wheels *c*¹, at the rear end of the machine, are mounted in bearings supported by a pair of arms *D*, pivoted to brackets *a*⁴, attached to the rear end of the frame *A* of the machine, and having their lower ends provided with adjusting nuts *d*, working on threaded stubs *d*¹, extending through slots *a* of the brackets *a*⁴, so that the tension of the feed chains may be at all times adjusted and chains of different lengths employed to suit cards of varying widths.

The card holder *E* is provided with a lip *e* at its front end, which forms an acute angle with the floor *e*¹ of the holder, so that when the cards *F* are stacked on the holder, ready to be fed to the feed chains, the upper edges *f* will project slightly one above another, thereby enabling the operator to readily grasp with the thumb and forefinger a single card at its upper edge without any delay in separating it from the card adjacent thereto. From their position on the holder *E* the card is placed on the auxiliary feeder *G*, which rests normally with its face inclined toward the holder *E*, and is provided with spring retaining hooks, beneath the free ends of which the card is passed in applying it to the auxiliary feeder. The auxiliary feeder *G* is fixed on a rock shaft *g*², provided with a pinion *g*³, which engages a toothed sector *g*⁴ on a vibrating arm *g*⁵, which arm is connected by a link *g*⁶ with one arm of a bell crank lever, pivoted to the frame at *g*⁷ and operated by a cam *g*⁸, actuated by the driving shaft *R*.

The lacing needles *H* are adapted to reciprocate the needle bars *h*, having series of teeth *h*¹ thereon arranged to gear with pinions arranged at suitable intervals along a rock shaft *h*², supported in bearings in brackets *a*⁶. The shaft *h*² is rocked to reciprocate the needle bars, and hence the needles, by means of a pinion *h*³, carried thereby, and arranged to engage a toothed sector *h*⁵ on a swinging arm *h*⁶, connected by a rod *h*⁷ with one arm *h*⁸ of a bell crank lever, the other arm of said bell crank lever being arranged to engage a cam groove *h*⁹ in the side of a cam wheel *h*¹⁰, operated from the drive shaft.

The shuttles *I* are each mounted in a tilting holder *K*, supported by a rocking arm *L*, each of the arms *L* being fixed to rock with a shaft *l*, supported in a bracket *a*⁷, depending from the frame *A*. The arm carrying the middle shuttle has an operating rod connected therewith above the rocking shaft *l*, the opposite end of said rod being connected with an eccentric, carried by the drive shaft *R*. This rod thus serves to rock the three shuttle supporting arms *L* in unison. The shuttle holder *K* is hinged at 1 to a base piece 2, the stem 3 of which is fixed to the rocking arm *L* in adjustment longitudinally of the arm, and the rear end 4 of the holder is provided with an elongated slot 5, through which an adjusting screw 6 extends to lock the holder to the base piece or shuttle holder support in the desired tilting adjustment.

The shuttle holder *K* is provided with a finger 7 for holding the nose of the shuttle against the side wall of the raceway and with a lip 8 for holding the body of the shuttle at its rear end against the side wall of the raceway and with a retaining lip 9 at its rear end, which acts in conjunction with the finger 7 to hold the shuttle against longitudinal displacement in the holder. The side wall *M*, in proximity to which the shuttle is intended to travel, holds the shuttle against displacement in that direction, and the top wall *M*¹ of the raceway, prevents the shuttle from displacement in that direction when the shuttle holder is tilted into its position to bring the shuttle into operative position in the raceway. The shuttle is removed from beneath by tilting its holder *K* downwardly at the heel, and then lifting the rear end of the shuttle out of engagement with the lip 9. The tilting adjustment of the holder on its support thus performs two functions, *i. e.*, the heel of the shuttle holder may be tilted downwardly, so that the shuttle itself may be removed from its holder without disturbing any other parts of the machine, and at the same time this tilting adjustment coacts with the adjustment of the shuttle holder support itself to place the shuttle in the exact position required with respect to the raceway, so as to make it work with the least possible friction and catch the loop

of the needle positively. The lacing cord is led from the core of the ball P down through the stem of the cup o^4 and socket piece o^3 to guides on a curved arm o^5 , attached to the stem of the cup o^4 or to the socket piece, and thence leads to a tension device o^6 on the needle bar support, thence to a guide o^7 onto the needle bar support in proximity to the needle bar, thence up and through an eye o^8 at or near the upper end of the needle bar, and thence downwardly through a guide o^9 to the needle.

The shuttles being driven directly from the drive shaft by an eccentric thereon, will be caused to complete a reciprocating movement for each revolution of the drive shaft, and as the needles are operated by the cam h^{10} on the shaft R in order to impart to them a reciprocating movement for each movement of the shuttle, the cam h^{10} is provided with three radially extended portions and three reëntrant portions alternating with the extended portions, so that in one revolution of the cam h^{10} the needle has imparted to it three vertically reciprocating movements. By thus operating the needle through an independent operating mechanism, a longer movement in an upward direction intermediate two successive shorter movements in an upward direction is imparted to the needle, and thereby cause it to draw an additional amount of cord from the supply balls to accommodate the longer stitch, which occurs between the two lace holes at the opposite edges of a card. This is accomplished by making one of the three reëntrant portions of the cam wheel h^{10} extend (the portion denoted by x) nearer the centre

card a distance equal to the distance between the lace-holes upon its opposite edges, and which long step of feed is provided for by the portion x^1 of the cam c^6 , which permits the operating arm of the lever c^5 to approach nearer to the centre of the cam c^6 than the other reëntrant portions of the cam permit, and hence causes the feed pawl c^2 to engage the ratchet disk a tooth in advance of that which it would ordinarily take, and hence increases the length of feed at that step by the width of that tooth. (John Royle & Sons, Paterson, N. J.)

MISCELLANEOUS.

THE CROMPTON-THAYER CRANK SHAFT BOX.

The distinctive feature of this box, as applied to the Crompton-Thayer Looms, is that instead of being like an ordinary box, divided into two very nearly equal pieces, the upper bolted to the lower by two or more bolts or set screws running at right angles to the line which separates them, this new box is so made that only a small part is taken out of the upper half, which half is held in its position by a bolt running obliquely across the box.

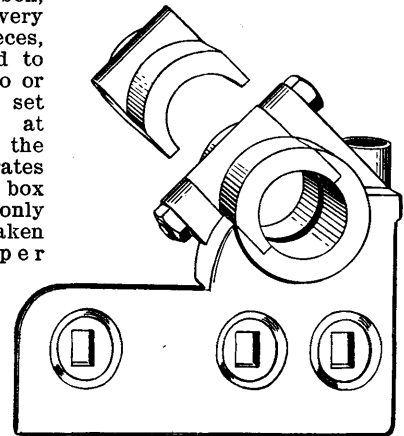

It will be easily seen, that the upper portion of this box cannot break loose, which happens so often and is so annoying in the regular crank shaft box. (Crompton-Thayer Loom Co., Worcester, Mass.)

OIL GUARD FOR THE SHEDDING CAMS.

This guard is built by the Draper Co., and is shown in the accompanying illustration in its perspective view.

The object of said guard is to prevent the cams from throwing oil upon the warp during the running of the loom, thus obviating grease spots which had to be removed later on from the cloth.

One of these oil guards is used for each cam and comprises an elongated plate o , provided with downturned strengthening flanges 1, which are gradually extended as at 2, and are provided with open slots 3, which fit into projections on the cam treadles. The guards rest by their own weight on the cams and

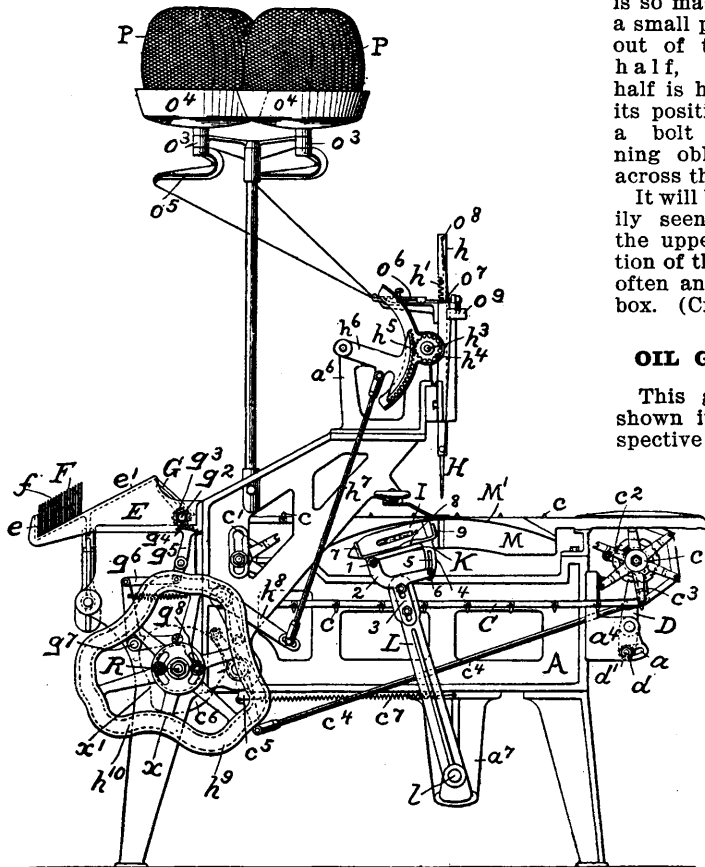
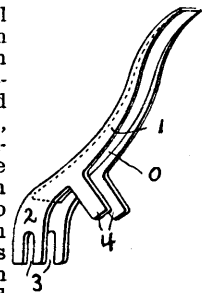

travel with them, each guard being kept from lateral movement by two ears 4, straddling the treadles. (Draper Co., Hopedale, Mass.)

of the cam wheel than the other reëntrant portions. This extended upward stroke of the needle bar anticipates the long step of feed which carries the

THE CROMPTON-THAYER LAY CONNECTOR.

This new lay connector as used on Crompton-Thayer looms, is shown in the accompanying illustration, and has for its merit the fact that it is adjustable, that is, the band around the crank arm or around the lay pin may be tightened or loosened by the weaver very easily, by simply tightening or loosening the bolt that lifts or depresses the wedge or cam, which is shown quite clearly in the illustration, then tightening the other bolt causes the strap to clinch the connector. Thus, it is very easy for any weaver to tighten or loosen the band at either end of the lay connector without calling upon the services of a loom fixer. (Crompton-Thayer Loom Co., Worcester, Mass.)

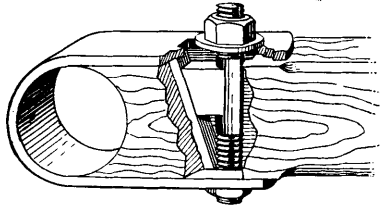

DRIVING MECHANISM FOR C. & K. LOOMS.

The object is to provide to their heavy looms (which require considerable strength on the part of the weaver to push back the lay after the loom is stopped to insert new filling, etc.) means whereby this mechanism is easier reversed, thus permitting the weaver to more easily turn the lay back by hand when so required.

The illustration is a right hand end view of a loom showing this mechanism and its connection with the shipper handle, by which it is operated.

The bevel gear 1 (loose on shaft 4), which drives the gear 2, has attached thereto a friction disk 3,

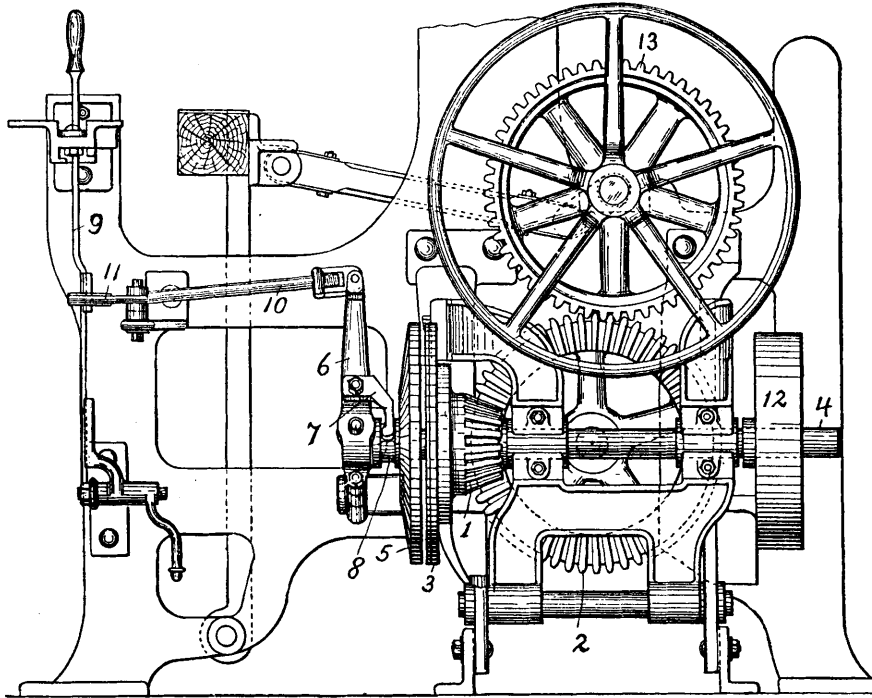

said gear 1 being provided with an oil reservoir which acts to lubricate the shaft 4 on which the disk is

mounted. A second friction disk 5 is slidably mounted on shaft 4 so as to be moved into and out of engagement with the disk 3 through lever 6, carrying the forked arm 7, which engages the grooved hub 8 on the disk 5. The lever 6 is operated by the shipper lever 9 through the connector 10 and angle lever 11.

The operation is as follows: Power is communicated to the cross shaft 4 through belt pulley 12, and the friction disk 5 revolves with shaft 4, and when the loom is in operation the friction disk 5 will be in engagement with the friction disk 3, causing said disk and bevel gear 1 to rotate with the disk 5 and the shaft 4 and communicate motion to the gears 2 and 13.

When the shipper lever is moved to stop the loom, the friction disk 5 is moved out of engagement with the friction disk 3, leaving the friction disk 3 and bevel gear 1 stationary, while the shaft 4 and the friction disk 5 continue to revolve. This will permit the weaver to more easily push the lay back, when so required, since for this purpose he, in pushing back the lay, will only have to reverse the gears 2 and 13, and the bevel gear 1 and friction disk 3 without moving the shaft 4.

In starting up the loom by moving the shipper lever, and causing the friction disk 5 to move into engagement with the friction disk 3, the momentum of the revolving shaft 4 will cause the loom to start more quickly than if the shaft 4 were stationary at the time the loom is started, and the bevel gear 2, meshing with the bevel gear 1, will tend to crowd or push the gear 1 outwardly, thus securing a better friction between the two disks. (Crompton & Knowles Loom Works, Worcester, Mass.)

FRICITION PULLEY FOR C. & K. LOOMS.

In previous constructions of friction pulleys considerable leverage is required to maintain the loose pulley in contact with the friction pulley, in order to drive the loom, this leverage in turn causing friction on the bearings of the driving shaft, and consequent waste of power, as well as an end thrust to the shaft when the loom is started. The object of the new friction mechanism is to provide means for drawing the loose pulley against the friction surface and locking it in its position when in contact with the friction surface.

The illustration is a sectional view of the new friction pulley mechanism, showing the driving pulley out of engagement with the friction disk. Examining this illustration we find that on the driving shaft 2 is loosely mounted the driving pulley 3. 4 is a driving gear, secured on the shaft 2 by a spline 2'.

The friction surface is made in the shape of a circular disk 5, provided with a hand wheel 5', and having the arms 5'' secured by bolts 6 and nuts 7 to the gear 4, and with a friction surface consisting of a ring of leather 5''' secured on the face of the disk 5, adjacent to the

friction surface consisting of a ring of leather 5''' secured on the face of the disk 5, adjacent to the

driving pulley 3, which is loose on shaft 2, and adapted to be moved thereon in the direction of the length of the shaft. A friction band wheel (not shown) is secured to the gear 4, and around said wheel passes a friction band, which is brought into engagement with said friction wheel when the shipper is thrown off.

The mechanism for moving and locking the driving pulley 3 consists of a collar 10, loosely mounted on the turn down hub 3' of the pulley 3, and having an annular groove 10' therein, said collar also having oppositely extending lugs or ears 10", to each of which is pivotally connected by a pin or stud 11, one end of a connector 12, forked at each end. The opposite forked end of each connector 12 is pivotally connected by a stud 13 with the head 14 of a bolt 15. Each bolt 15 is screwed into the outer end of a curved rocking lever 16, which is pivoted at its inner end on a stud 19, supported between two arms

the sliding bars. Within the open end slot 21' of each sliding bar 21 is secured a piece of leather 22.

The operation of the locking mechanism for moving the pulley is as follows: The drawing forward of the shipper lever by the weaver to move the pulley 3 into contact with the friction surface 5"', will move the collar 10 in the direction of arrow *a*, and cause the rocking levers 16, through connectors 12 and bolts 15, to be moved on their pivotal supports, and move the sliding bars 21 to cause them to engage the annular flange 5'''' on the friction disk 5, and move the driving pulley 3 on the shaft 2 into engagement with the friction surface 5'''' on said friction disks 5. This movement of the collar 10 brings the studs 11 into alignment with the studs 13 and holds the rocking levers 16 and sliding bars 21 to lock the pulley 3 to the friction disk. When the shipper lever is moved into the opposite direction to stop the loom, the collar 10 is moved into the position shown in the illustration, and if the pulley 3 and friction surface 5'''' do not disengage readily, the lip 21'' on the sliding plate 21, coming into contact with the flange 5'''' on the friction disk 5, will force the pulley 3 away from the friction disk 5. (Crompton & Knowles Loom Works, Worcester, Mass.)

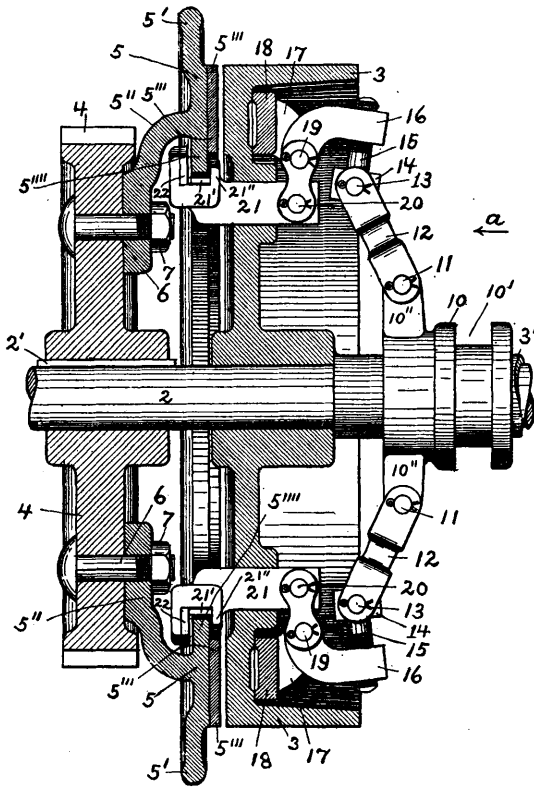

17, extending out from a plate 18, secured by bolts to the pulley 3. A stud 20 pivotally secures the forked end of each rocking lever 16 to one end of a sliding bar 21, which extends in the forked end of the lever 16, and has its bearings in an opening in the pulley 3. The opposite end of each sliding bar 21 has an open end slot 21' to extend over and receive an inwardly projecting annular flange 5'''' on the friction disk 5. The end of this sliding bar 21, by means of the slot 21', receives the annular flange 5'''' of the friction disk 5, so that sliding movement of the bar 21 in either direction positively moves the friction disk or pulley either into or out of engagement with each other by the walls of the slotted ends of the sliding bars engaging opposite sides of the flange, and also that the flange of the friction disk remains at all times in engagement with the slot 21' of the sliding bar 21, thus insuring positive action of the friction disk upon any movement of

TILTING REED MECHANISM FOR C. & K. LOOMS.

In weaving chiffon, gauze, veiling, and other extremely light fabrics, a mechanism is provided to the loom for compensating for irregular filling, as well as for a lost pick, the reed being so constructed that it will always spring back a short distance in beating up the filling, except when the filling breaks or runs out, in which case it does not spring back as far, so as to make up for the lost pick.

The object of the new device is to improve upon the mechanism thus explained, by providing means so the filling is beaten up by the reed when it is in a sloping position, the warp threads having a tension sufficient to cause the fabric to slide up the incline made by the reed at each pick.

In case the filling then breaks or runs out, the fabric then does not slide up the reed as far, thereby making up for the lost pick and preventing thin places in the fabric, the reed at the same time taking an upright position on the lay while the shuttle is passing across.

Of the accompanying illustrations, Fig. 1 is a side view of the lay, the lay sword, reed, as well as the new mechanism, showing also a portion of one of the side frames of a loom, showing the reed in its sloping position. Fig. 2 shows the lay in its rear position with the tilting reed in its upright position.

1 indicates a portion of the loom side or frame, 2 the lay sword, mounted at its lower end on the shaft 3, supported in bearings 4' on the stand 4, bolted to the frame 1. On the upper end of the lay sword 2 is secured the lay 5 and the hand rail 6. Rocking motion is communicated to the lay in the ordinary way.

A stand 7, having an elongated slot 8 therein, is secured to the lower part of the frame 1. A stud extends through the slot 8 and is adjustably held therein by means of a collar or washer and a nut. Pivoted on the stud, thus referred to, is an arm, having a boss 9 on its outer end to receive the lower end of a rod or connector 10. On the lower end of the connector 10, below the boss 9, is adjustably secured by a set screw 11' a collar 11. A spiral compression spring 12 encircles the connector 10 between the boss 9 and a collar 13, adjustably secured on the connector 10 by a set screw 13'. The upper end of the connector 10 is pivotally attached to a stud 14 on a rearwardly extending arm 15 on

the tilting frame carrying the reed 16. The tilting reed frame, only one end of which is shown in the

NEEDLE OPERATING MECHANISM FOR C. & K. LAPPET LOOMS.

This mechanism provides means whereby the range as well as variety of movement of the needle bars in a lappet loom are greatly increased, with the result that a larger range of patterns can be woven than heretofore possible. Two pattern surfaces are provided, each having varying heights and a separate lever, which, through a joint connection, operates the needle bar, having thereon the needles which carry the lappet threads longitudinally in the loom.

The movement of either lever or both levers, by the action of their respective pattern surfaces, communicates a longitudinal movement to the needle bar, thus placing the needles carrying the lappet warp threads in varying positions over the sheds of the regular weaving warp threads, and thus interweave said lappet warp threads on the surface of the fabric so as to produce the desired design. Different elevations of the two pattern surfaces are generally used to produce any desired figure by the resultant movement of the needle bar.

One of the pattern surfaces for operating its respective lever may be provided for several successive picks or movements of the pattern surface with elevations of the same height, so that the lever will remain at rest, while the other pattern surface, which operates the other lever, may have elevations of varying heights, so that the movement of the needle bar will be governed only by the lever of the latter pattern surface.

Again, the two pattern surfaces may be provided with elevations of varying heights, and when in turn the two levers of said pattern surfaces will act, through the connection to the needle bar, to communicate to said needle bar a

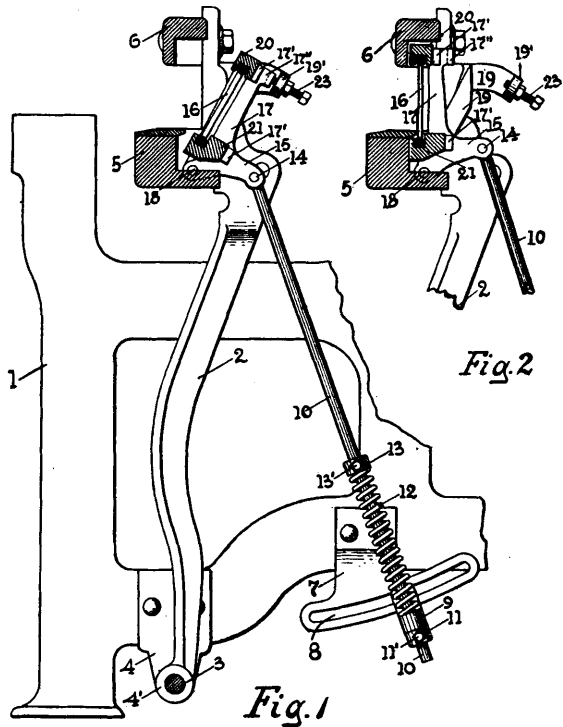

drawings, has in this instance an end bar 17, which is pivotally mounted at its lower end in this instance on a stud 18 in the lower end of a bracket 19, secured by a bolt to the rear of the lay horn. The top bar 20 and the lower bar 21 of the tilting reed frame are grooved longitudinally to receive the upper and lower edge of the reed 16 and hold the same in the tilting frame. The ends of the bars 20 and 21 are secured by screws to inwardly extending lugs 17' on the end bar 17. The end bar 17 has an outwardly extending projection 17", which in the backward tilting of the reed is adapted to engage an adjustable screw 23 to limit the tilting movement of the reed. The screw 23 is in this instance adjustable in and out in an extension 19' on the bracket 19.

The operation of the mechanism is thus: On the rearward motion of the lay, the spring 12 on the lower end of the rod 10 holds this rod and prevents its lower end from being moved through the boss 9, and consequently the tilting reed will be moved from its inclined position (shown in Fig. 1) into its upright position (shown in Fig. 2) preparatory to the throwing of the shuttle. As the lay beats forward, the tilting reed moves with it, and the rod 10 moves up through the boss 9, until the collar 11 engages said boss 9 and prevents any further upward movement of the rod 10, so that the rod holds the tilting reed and its supporting frame and brings it into an inclined position, as shown in Fig. 1, as the lay continues to move forward to its extreme forward position. The inclined position of the reed causes the fabric to slide up the incline made by the reed, however, if the filling breaks or runs out, the fabric does not slide up the reed as far, thereby making up for the lost pick and preventing thin places in the structure. (Crompton & Knowles Loom Works, Worcester, Mass.)

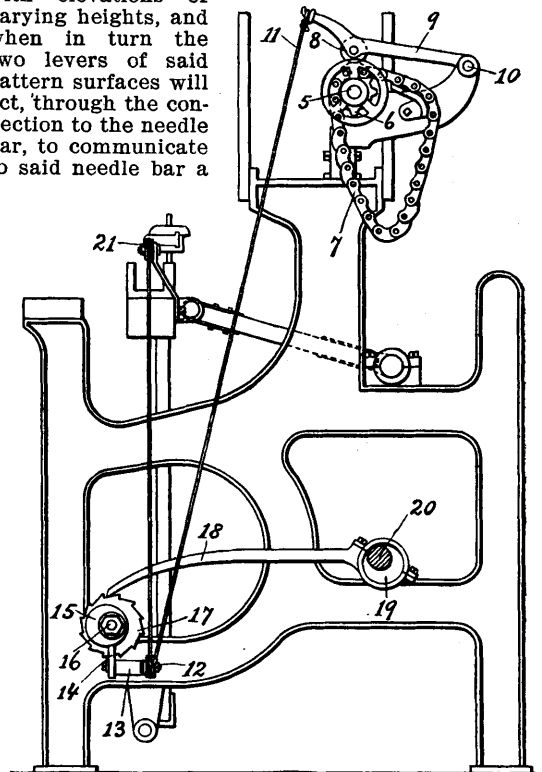

Fig. 1.

movement equal to the combination of movements produced by each of said levers.

In order to give this increased movement to the needle bar over that produced by the movement of

one lever only, the needle bar is flexibly connected to both levers by having the connection, which is fastened to the top lever, extend down and around a pulley secured on the bottom lever, then up again, over a pulley situated on the lay, and connected to the needle bar. The movement of the pulley on the

shaft 16, said shaft being properly set in bearings and also carrying the ratchet wheel 17. This ratchet wheel is rotated by means of the pawl 18, which receives its reciprocating motion from the eccentric 19, fast on the bottom shaft 20, to which it is connected. Through the rotation of the ratchet wheel 17, the cam 15 is also revolved, and being in contact with the plate 14, on the lever 17, presses the lever down according to the outline of the cam, and hence the pulley 12 is also moved downward.

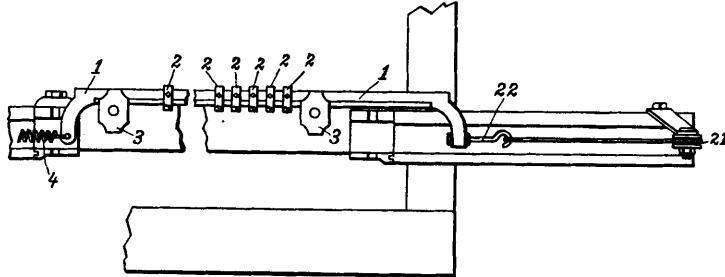

Fig. 2.

lower lever in the loop of the connection, by means of combined action of both levers in this instance, produces the increased movement of the needle bar over that produced when only using one lever.

Of the accompanying illustrations, Fig. 1 is an end elevation of a loom frame and lay showing the improvements applied. Fig. 2 is a plan view of a portion of the loom frame and lay, the needle bar and connections, detached from the loom.

1 indicates the needle bar, which carries the clamps 2, holding the lappet thread needles, said needle bar 1 sliding longitudinally in the slides 3. To one end of the needle bar 1 is attached a spring 4, also fastened to the loom, which acts to pull the needle bar back toward its original position after having been pulled in the opposite direction by the connection at the other end. The mechanism by which the needle bar is raised and lowered in order to weave the lappet threads into the cloth, is not shown in the illustrations, as the connection is the same as for ordinary lappet looms.

The connections of the pattern surfaces to produce the desired pattern on the cloth are given as

As stated before, the connection from the top lever is passed under this pulley and up to the pulley 21 on the lay of the loom, in turn passing over the pulley and being connected to the needle bar 1, through the link 22, so that any movement of the connection 11 will be transmitted to the needle bar 1.

Hence we have two pattern surfaces, viz., the pattern chain, and the cam, the levers which are operated by them being connected to the needle bar by the flexible connection 11. A movement of either lever or both will cause the needle bar 1 to be pulled outward, after which the spring 4, on the other end of said needle bar, will bring it back into position and also hold the levers 9 and 13 in contact with their pattern surfaces. To illustrate the variation which may be obtained by the use of two pattern surfaces, let us take a concrete example. Suppose the bottom lever is pressed down half an inch by the cam, and the position of the connection 11, previously described, then through the connection 11, previously described, the needle bar will be moved outward half an inch. Now suppose that at the same time the lower lever is moved down, the top lever is raised by the chain, then the combined movement of the levers will be transmitted through the flexible connection to the needle bar. (Crompton & Knowles Loom Works, Worcester, Mass.)

ATTACHMENT FOR LAPPET LOOMS.

This is another attachment for increasing the range of patterns in connection with this class of looms quickly and economically, the positions of the figures in relation to each other being changed at any time

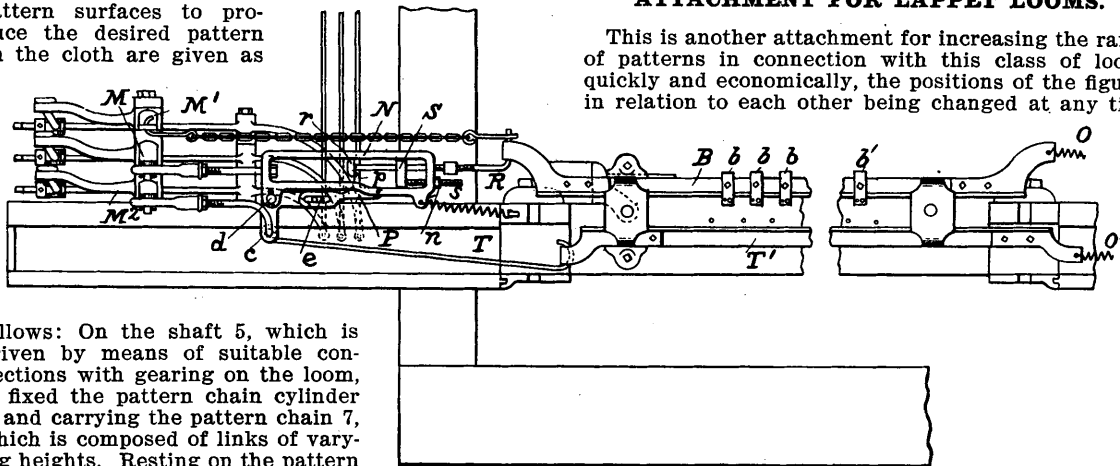

follows: On the shaft 5, which is driven by means of suitable connections with gearing on the loom, is fixed the pattern chain cylinder 6, and carrying the pattern chain 7, which is composed of links of varying heights. Resting on the pattern chain directly over the chain cylinder is a bowl 8, carried by the lever 9, which has one end pivoted on the pin 10, the other end being connected to a flexible connection 11. This connection 11 extends downward to a pulley 12, situated on one end of the angle lever 13, said angle lever being pivoted at its other end to a projection on the loom frame, and carries a plate 14, near the central angle in its length. Directly over this plate 14 is a cam 15, fixed on the

by stopping the loom for a brief period and simply adjusting a special device supplied to the loom, without in any way manipulating or changing the pattern card or chain.

The accompanying illustration is a top plan view of the needle bar, showing the locking, adjusting and releasing devices and their connection with their operating mechanism.

Examining the illustration, we find that the lappet thread needles are attached to clamps *b*, and by them are secured to the bar B. By the action of a spring O, this bar always has the tendency to assume its extreme right hand or normal position, which it will do when not acted upon by the operating parts at its opposite end. The new device itself comprises a rod R, held in, and arranged to slide through, a hole in the end of the frame N and also through a hole in the stop block S, which is capable of adjustment longitudinally of this frame between its two sides. The rod R is provided with a projection or head *r* upon its left hand end, and its opposite end is attached to the bar B. When the bar B is in its normal position, and the pattern chain operates the bell crank M, the frame N is reciprocated and with it the bar B, to which the frame is connected by the rod R. During this time a series of figures are woven into the fabric, and when completed, the bar B, with its attached needles, is raised, and the pattern chain operates the bell crank M', whereby the bar B is pulled to the left, and through its attachment to the bar B, the rod R will also slide to the left through the hole in the frame N and block S until the head *r* strikes and passes over the projecting lip *p* of a latch P, which will yield by reason of its connection with a spring O' through the rod T and sliding bar T'. The lip *p* will then engage the back side of the head *r* and hold the bar B in that position in relation to the frame N.

While in this position the pattern chain again operates the bell crank M, causing the bar B to reciprocate and weave another series of lappet figures. As soon as that series of figures is completed, the bar B is again raised and held in this position until the portion of plain fabric is woven. Then the lip *p* of the latch P is withdrawn from the head *r* by the action of the bell crank M², which is connected with one arm of a bell crank lever *c*, pivoted in the frame N at *d*, while the other arm of the lever *c* is provided with a stud which engages a slot *e* in the latch P. The bar B thus released is pulled back again to its normal position by the spring O, which position is determined by the stop block S, against which the head *r* of the rod R is brought to bear and when operation is repeated.

If it is desired to weave a piece of fabric with each adjacent pair of longitudinal lines of figures nearer together or farther apart, all that is necessary to do is to change the position of the stop block S in the frame N by turning the adjusting screw *s* in or out in a threaded hole in the end of the frame N, and when the block S is in the desired position, turn up the check nut *n* to prevent any accidental movement of that screw, thus doing away with the necessity of changing the pattern chain so as to vary the amount which it will pull the bar B when it is shifted from one position to another. (Pierce Mfg. Corp., New Bedford, Mass.)

CLOSE SETTING OF FIGURES IN SWIVEL LOOMS.

The object is to provide means whereby the figures produced in the fabric are closer set than is possible in common swivel looms.

The accompanying illustration is a three-part plan view of the swivel rack with the improvement applied; Part I showing the swivel rack in its normal position; Part II showing the rack lowered ready

for the swivel shuttle to operate; and Part III showing the swivel rack lowered but not provided with the improvement.

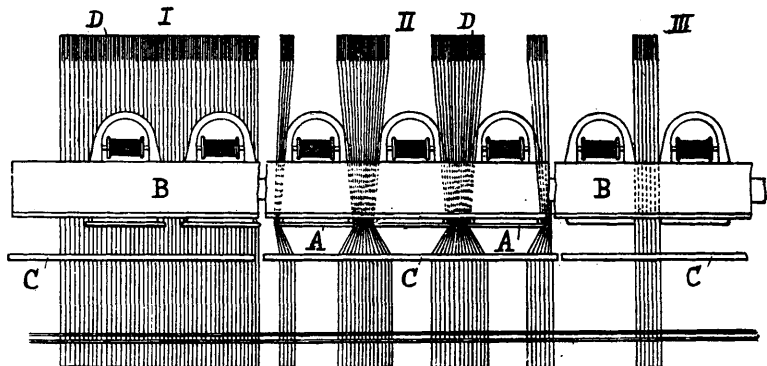

The improvement consists of a series of tapered plates A, secured to the back of the swivel rack B, one of said plates being so placed between such warp threads as to produce one set of figures in the cloth, said plates being adapted to pass between these warp threads when the swivel rack is lowered. When the respective threads for forming the shed for the passage of the swivel shuttles are raised and the rack is lowered, as shown in section II, it will be seen that the tapered plates A confine a large number of the warp threads into the proper space between the shuttles, which threads, after the shed is closed, spread out again into their proper position before the reed C, as the latter beats up the filling to the fell D of the cloth. (Joseph Wadsworth, Paterson, N. J.)

ATTACHMENT TO SUSPENDER LOOMS.

The attachment has for its object to wind (and thus cover and in turn strengthen) each of the two

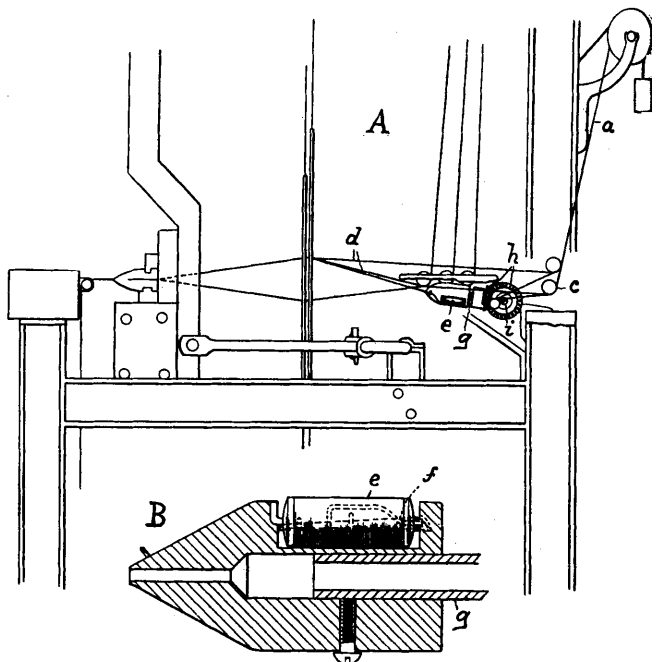

outer rubber strands as situated at either edge of the web, with a cotton or linen thread, in order to

protect said rubber strands from the abraiding action of the reed during weaving.

Diagram A is a side elevation of portion of a loom, showing the new attachment applied thereto, and Diagram B is a central longitudinal section (more in detail) of the new attachment as it is situated in the loom in rear of the harnesses, and of which there is one required for covering each rubber strand.

The rubber strands *a*, as coming from their beam spool *b*, in their travel to the harnesses for weaving, pass under the guide roll *c*, and then along with the regular warp threads *d*, to the harnesses, for weaving into the fabric. Previous to reaching the harnesses, the two outside ends on either side edge of the fabric, each passes through the core of one of the new attachments (see Fig. B), of which thus four are required for each web. These attachments correspond in their construction and operation, and carry mounted in them a spool of cotton or linen thread *e*, to which tension is applied by spring *f*. A hollow shaft *g* (through which the respective rubber strand passes) gives this spool carrier a rotary motion through the rotation of pinions *h* by means of shaft *i*, and thus winds or coats the rubber strand with the cotton or linen thread as coming from spool *e*. (Russell Manufacturing Co., Middletown, Conn.)

SIZING OF COTTON YARNS.

Sizing is one if not the most important department in a cotton weaving mill, since upon it depends quantity as well as quality of work turned out, requiring for this reason: (1) the proper ingredients to be used, (2) the greatest care and attention on the part of the operator, (3) the most approved machinery; for unless warp yarn is properly sized and handled, it will not weave well.

The object of sizing is to form a film on the surface of the yarn prior to weaving, which besides giving additional strength to the thread, in order to withstand the tension necessary for weaving, at the same time prevents the loosely adhering fibres from rubbing up, and thus causing what is generally known among weavers as "buttoning," which is produced by rubbing action of the heddles and the reed during weaving, especially when dealing with single yarn and more so in connection with high textures.

Another important reason for sizing, in connection with a great many fabrics, is to give additional weight to the goods, produced by the addition of some percentage of foreign matter to the yarn, and what is done by saturating the yarn with some suitable adhesive material of considerable specific gravity, the constituents of the composition depending, amongst other things, on the use which is to be made of the yarn and the class of fabric which has to be produced from it.

Yarns for bleaching or dyeing should be only very lightly sized, and besides only the best quality of size used, since otherwise the goods, when finished, will be faulty in appearance, for the reason that the fibres and the size will be differently affected in these processes.

The less twist in the yarns the more readily the latter will absorb size, for which reason a soft twisted thread, produced from a strong and coarse fibred cotton, should be used when heavy sizing is required.

The size must be of such a character that it will adhere firmly to the yarn, both while wet or dry and retain this attachment to the yarn during weaving. For this reason, the size, whether for light, medium or heavy sizing, must therefore be of uniform thick-

ness and consistency throughout, in order to saturate the yarn thoroughly.

The quantity and strength of the size to be put on to yarn depends upon circumstances, and can only be regulated by experience; but when this is once determined upon, the operator of the slasher must look after and keep the temper of the size regular and at one thing. The yarn after being sized must not be allowed to go on to the loom beam until perfectly dry. When the slasher is standing, the yarn should be taken out of the boiling size, by winding the roller that keeps the yarn submerged out of the size box, since otherwise the ends of that portion of the warp thus remaining in the size box will all get glued together.

The weight of size which can be added to a yarn depends upon the class of yarn, the class of cloth into which it has to be woven, the amount of twist in the yarn, the kind of size used and the manner in which the same is applied.

The materials used in sizing may be classed under different headings, according to their respective properties; but this classification cannot be strictly adhered to, as some bodies come under two or more of the following headings:

- 1st. Adhesive bodies.
- 2nd. Softeners.
- 3rd. Weighting bodies.
- 4th. Antiseptics.

(1) *Adhesive bodies*: These are flours of some sort, such as corn, farina, wheat, rice, etc., the first two, corn starch and potato starch (farina) being the ones most frequently used, some mills preferring one kind, some the other. Both flours refer to "light sizing" and require the addition of a softener, to counteract the harshness they give to the yarn if used alone. Wheat flour is extensively used for "heavy sizing," since it fixes weighting substances well and at the same time leaves the warps less harsh than other starches. Rice starch is much crisper than wheaten flour; it produces a thicker paste, but is less adhesive than the latter, and for heavy sizing the wheat flour is often adulterated with it. For light sizing it can be used alone, as a much smaller quantity will produce a thicker paste than that of wheat flour.

(2) *Softening bodies*: The adhesive bodies previously mentioned, if used alone, and more so if combined with weighting bodies, will make the yarn hard and harsh, besides when dry brush or crumble more or less off the yarn. If yarn is made harsh by the size, this feature enters into the cloth, and if the size brushes off by friction on the threads, it will be readily seen that the advantages aimed at in sizing have become lost. To avoid such results, substances technically termed softeners are added into the mixing, these softeners being of an oleaginous character.

Tallow is the most common softener used, there being mutton and beef tallow, and of which beef tallow is the better of the two, as it is not so liable to become rancid as mutton tallow. Tallow varies considerably in color, freedom from gritty matters, melting point, smelling, etc., however it is easy to distinguish good from bad. Tallow, exposed to the atmosphere, should not darken in color, for if it does, it is a sign of inferior quality and should be promptly rejected. The same with rancid tallow, which on account of its odor will be readily detected. A good valuable tallow should not contain water to any perceptible degree, since this will reduce its softening properties. This adulterant, as a rule, can be detected by the feel, but if in doubt liquefy a sample of it and when the water and oil will show itself distinctly. A high melting point, about 110° F., is also a necessary feature for a good tallow.

Other softening agents sometimes used are: Japan

wax, which gives most excellent results, but is rather expensive; Paraffin wax, which is cheaper than the former, but cannot be used when cloth later on has to be dyed, bleached or printed, owing to its color and chemical action; Castor oil, is a good softener; Soap is also very frequently used as a softener, although its true action when used for this purpose is not generally known. Soap besides being a softener also has the power of making China clay boil thinner. However there are also objections to the use of soap in size mixings, viz.: the same cannot be used to any extent in mixings which contain antiseptics without making the size lumpy; and, soap being of a frothy nature, it will rise in a scum or froth in the boiling vat. Soft or hard soaps, if used, must be of good quality and not dark in color. If soap is to be used, add only a small amount, and that to the China clay when the latter is being boiled separately from the other ingredients.

There is also a class of patent softeners in the market trading in many instances under high sounding names. In most cases the name being the greatest thing about it, some of them being composed of the most veritable rubbish, and in instances loaded excessively with water. Never use any of these preparations without first consulting a competent chemist, in order to ascertain whether its use will be economical or not.

(3) *Weighting bodies*: Amongst these we find—China clay, or Kaolin; Baryta, or heavy spar; French chalk, or talc; Plaster of paris, or gypsum; Steatite, or soapstone; Sulphate of soda, or Glauber's salt; Magnesium sulphate, or Epsom salts; Barium chloride.

The principal ingredient in use is China clay or Kaolin, which is a white or greyish-white body, having a soft, smooth feel to the fingers when rubbed. It is found only in few countries, and is the result of decomposition of felspathic rocks. It is an aluminium potassium silicate, and contains naturally 12 to 13 per cent. moisture on the air-dried sample. The qualities of this body upon the market are very

only show slightly by transmitted light. It should be perfectly free from iron and free acid. It is precipitated in the form of an oxychloride when water is added to it, and the white turbidity or milkiness is re-dissolved in excess of the chloride of zinc. It attacks iron with great rapidity, and should never be allowed to come in contact with that metal, as it at once begins to take it in solution. The liquid is often of 49° B., or a specific gravity 1.51, or a gallon weighs 15 $\frac{1}{10}$ lb. At this strength it should contain from 44 to 45% of pure zinc chloride. It is liable to adulteration, the chief adulterant being common salt. The solid form is simply the liquid form evaporated down until the solution attains a temperature at which the percentage of the zinc chloride is a constant, when it is then packed in lead-lined casks and hermetically sealed. At the destination the stuff is dissolved in water and made to a convenient strength.

Other antiseptics are carbolic acid, salicylic acid, arsenious acid, and perchloride of mercury, which however are of little, if any consequence for sizing.

A blue dye is sometimes used in very small proportions for the purpose of tinting, *i. e.* correcting a tendency to yellowness in the size mixing, and when said blue dye changes it to a bluish white.

CYLINDER SLASHING OR SIZING MACHINE, For Sizing or Starching the Yarn Preparatory to Weaving.

The Ordinary Cylinder Slasher consists of a machine with suitable iron frame made either continuously or in sections, containing one or two copper cylinders of different sizes made from the best heavy copper; also a starch box with the necessary sizing roll and the other attachments required for carrying the yarn through the machine with as little tension or strain as possible. It must also be remarked here that it is very desirable to dry the yarn at as low a steam pressure on the cylinders as possible, to preserve its elasticity and strength.

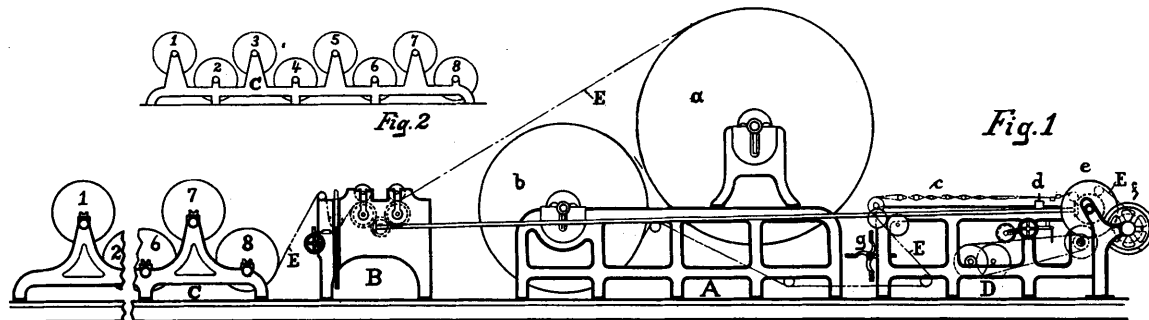

varied, and it is not always the whitest and the best looking variety that is the purest.

(4) *Antiseptics*: These are a class of bodies which are introduced into the size in order that the growth of mildew may be prevented. Their function is a destructive one, and wherever the spores are allowed to germinate, a tender yarn is the result.

The article most frequently used is Chloride of Zinc, or Muriate of Zinc, which fulfills two purposes, viz.: as an antiseptic for the prevention of mildew, and as a weighting body, hence its superiority over other substances used as antiseptics only. It is placed on the market in two forms, liquid and solid, and is prepared by dissolving zinc in muriatic acid, and as there is always some little free acid present this is neutralized by means of soda ash; the slight trace of iron that may be present is precipitated out, the liquor allowed to settle, then run off into vats to age. It is a pale yellow liquid, and the color should

Fig. 1 shows, in its side elevation, the latest make of the Cylinder Slasher as built by The Textile-Finishing Machinery Co., Providence, R. I. Examining this illustration we notice that the side frame of the machine is made (if so desired) in sections, a feature which has the advantage over the continuous-frame machine that it makes it easier to erect and align such a machine in the mill.

Section A of the machine carries the two drying cylinders *a* and *b*, the usual standard measurement of which is 7 and 5 feet diameter respectively \times about 60 inches face each. They are strongly, and at the same time lightly constructed, the heads being made of steel properly braced, while the joint between the copper shell and head are so made, that by having the edge of the copper turned and held between the head on the outside and a ring on the inside, with through bolts, that it is quite impossible to blow it out, even under excessive pressures.

These cylinders are also fitted with patent spiral scoops (see special article on these spiral scoops in the chapter "Finishing Machinery") which take out every bit of water and air so that the lowest amount of steam pressure can be used in drying the yarn, which in turn means that the yarn is dried at a very low temperature and the size not baked on.

The other sections of the machine are:

B is the section for holding the size box, which is usually a double jacketed copper box and contains

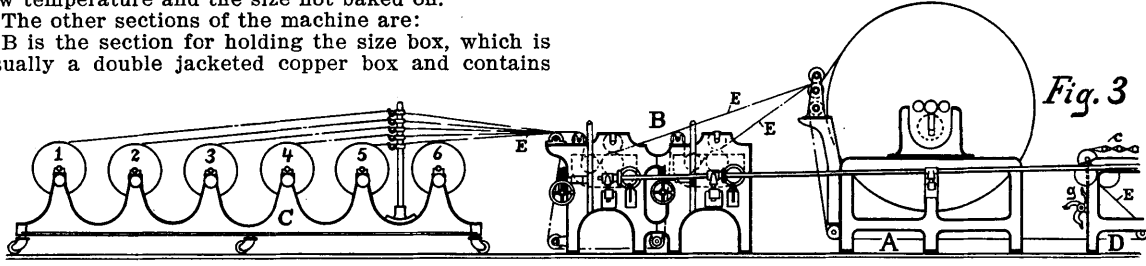

seamless copper electro plated balanced rolls.

C is the creel section, which in the usual construction of the machine provides bearings in its side frames for holding eight beams, arranged in 2 rows of four beams each. Only beams number 1, 7 and 8— are shown (besides portions of beams number 2 and 6) the central portion of the creel section being shown broken out, in order to bring the diagram of the complete Slasher within compass of the width of the page. In order to illustrate the complete creel section, detail illustration Fig. 2 is given (being drawn on a reduced scale to Fig. 1) and which will at once explain itself by means of numerals of reference selected to correspond with those used in connection with Fig. 1.

D is the head stock, *i. e.* head section of the machine, the frame work of it holding the rods *c* and reed *d* (expanding comb) both being necessary for separating the sized threads, also the mechanism *e*, for winding the yarn on the loom beam *f*. Fans *g*, at the entering-end of the head stock, are placed there for cooling purposes.

The run of the yarn, as taken from the beams in the creel section C—then passing through size box B—then in turn nearly all around drying cylinders *a* and *b*—then through the head stock D—and finally on the loom beam *f*, is shown by means of broken line E.

For regulating the speed of the machine and also for removing as far as possible the tension on the yarn, special drivings and friction devices are used, known in the trade as the McCarthy Friction Drive and the Pacific Wind.

The McCarthy Friction Drive is a mechanism for driving the Slasher Cylinders direct from side shaft, thus enabling all tension required to drive cylinders to be removed from the yarn, in turn allowing very light warps to be sized and dried without breakage or excessive strain. It is provided with friction attachments to regulate perfectly the speed of the cylinder to accommodate the sets required to be dressed. In making up sets for weaving, experience has proved that the ordinary arrangement of slasher can do good work to a certain limit, but when that limit is reached, it becomes necessary to use some such arrangements as the McCarthy Drive to do satisfactory work at a certain and constant speed. This arrangement will dress yarns of any number of threads, doing its work thoroughly and perfectly. It can be readily attached to any yarn slasher and requires but little out-lay. Its importance can be readily understood by those having experience with light warps or a small number of ends.

The single cylinder slasher, frequently termed a "Tape Dresser" is shown in its end elevation in Fig. 3. While very similar to the double or two cylinder

slasher, it is gotten up especially for dressing warps or yarn for ticking, gingham and all pattern work where it is desirable to use lease reeds at the size box. The particular machine represented was designed to take the place of what has been largely known as a "Scotch Tape Dresser." In this illustra-

tion A is the drying section, with its drying cylinder; B the size box (2 compartments in this instance); C the creel frame (6 beam-feeding), and D the first portion of the head stock (this being done in order to bring illustration within compass of the page) and which is identical with the one shown in connection with Fig. 1, and consequently will explain itself. E indicates the run of the yarn through the machine.

For preparing the starch for both these machines, the Textile-Finishing Machinery Co. make a size or starch kettle herewith represented in Fig. 4 that consists of an iron kettle with cover, mechanical means for boiling and stirring the size which consists of hollow stirrers with holes for delivering the steam to the size or starch and distributing it evenly through mass. By means of this size kettle the boiling can be done in half the time and one half the expense necessary

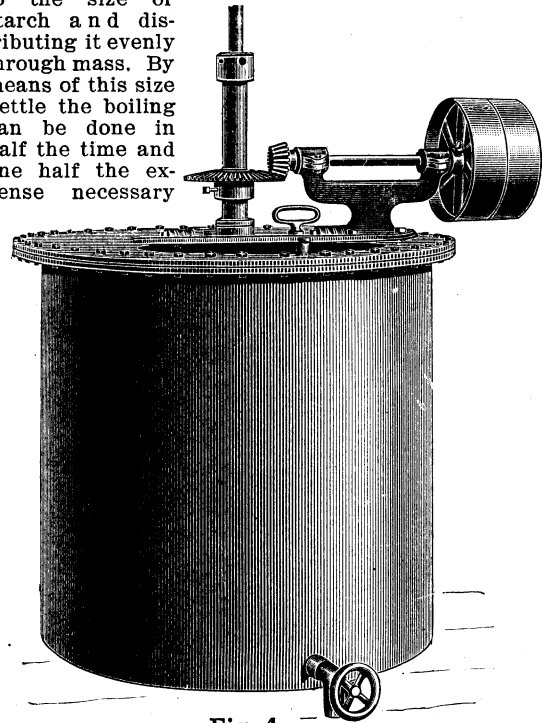
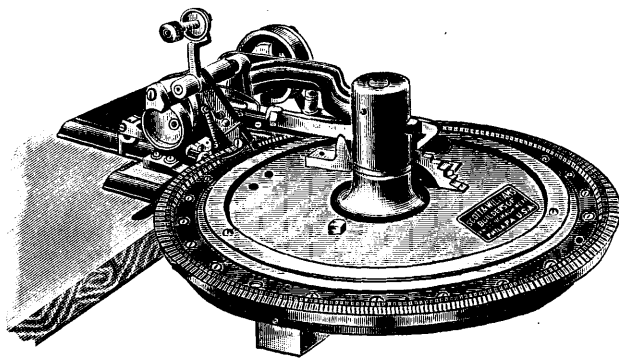
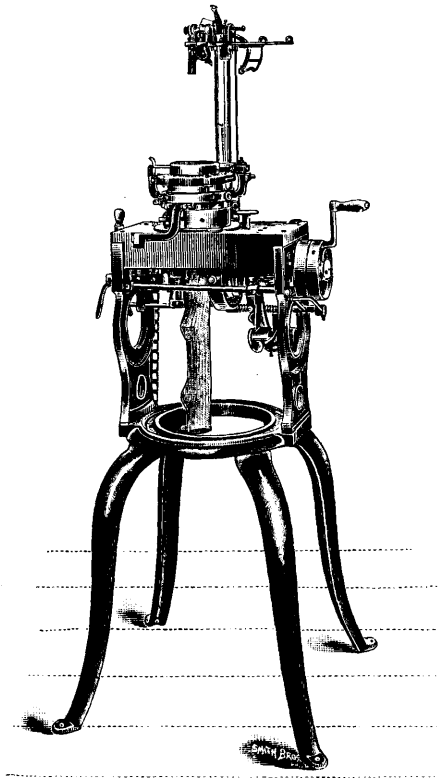
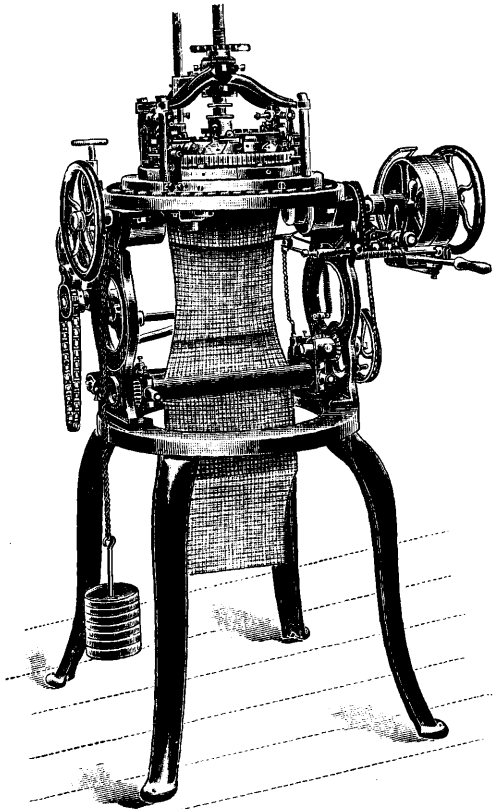

Fig. 4.

in any other arrangement now in use; again size thus prepared in one of these kettles is sure to be in proper condition for perfect sizing of the warp. Size unless well boiled retains a granular nature and in turn causes faulty cloth, a feature prevented by the use of one of these kettles. (The Textile Finishing Machinery Company, Providence, R. I.)

SCOTT & WILLIAMS

Builders of Circular Machines for Underwear and Hosiery



Improved High Speed Rib Knitting Machines for Underwear, Hosiery, etc.

Complete Line of Machinery for Making All Kinds of Seamless Hosiery

Loopers Fitted with Elastic Stitch Attachment

Quality and Quantity of Production Unexcelled

FOR FULL PARTICULARS, DESCRIPTION, ETC., ADDRESS

SCOTT & WILLIAMS, 2079 East Cumberland St., PHILADELPHIA, PA.

KNITTING.

Knitting forms one of the great divisions of fabric structure, and differs radically in the principle of producing the fabric, from that of weaving, being based on the principle of forming a fabric or web by means of a series of interlocked loops from one or more continuous threads. Different systems of interlocking the loops produce different styles of stitches, each being best suited for certain kinds of fabrics, etc.

The operation of knitting is done by means of knitting needles, there being two general styles in use, i. e. the latch needle and the spring beard needle.

THE PRINCIPLE OF THE LATCH NEEDLE.

Plain Stitch: The principle of knitting or making a stitch on the latch needle can be best explained by means of the accompanying illustrations Figs. 1 to 6, which are sections taken from the machine, showing the successive positions of the yarn and needles during the operation of making a stitch, also the general construction of a specimen of a latch needle. With reference to Figs. 1 to 4, only one needle has been used and the stitches shown as made by that needle, although it must be understood that each needle on the machine makes in turn a similar stitch from the same thread, and that the different loops or stitches, shown in these illustrations as different threads, are really only different portions of the same continuous thread, the stitches shown being made, one at a time, for every course, considering the yarn carrier as feeding one thread. In the illustration, 1 indicates the body of a latch needle, having a hook 2 formed at its upper end, the needles being only placed horizontally in the illustrations for clearness, as they work vertically in the circular knitting machine and at an angle in the flat knitting machine. Near the upper end of the needle is a pivoted latch 3, which is made so as to either rest over the end of the hook 2 and thus close the latter, or is turned backward to leave said hook open.

Fig. 1 is a diagram, showing the position of the needle and a loop *b* resting on it, when said needle is in its normal or resting position, the stitch *a* having been made previously by this needle. It will be noticed that the loop *b* is resting on the back turned latch 3, thus leaving the hook open. Fig. 2 shows the needle as it would be when raised to its highest position, in which it is seen that the loop *b* is resting on the needle behind the latch and the yarn *c* has been deposited in the hook of the needle. The needle is now given a downward movement and the latch and loop take the position shown in Fig. 3, said loop practically remaining stationary while the needle moves, thus causing said loop to close the latch as the needle slides in the loop. The loop *b* is now free to slide over the end of the closed hook, with the newly deposited yarn *c*, which also forms a loop, resting in the closed hook. The needle descends further until the loop *b* finally slides over the end of the hook, or is, what is technically termed, "cast off," as shown in Fig. 4. After casting off the loop, which we now call a stitch, the needle returns to the resting position, shown in Fig. 1 and the loop *c* takes a similar position of the loop *b* in that diagram.

Figs. 5 and 6 are given to show more in detail the construction of the latch needle, Fig. 5 showing the needle with the latch closed, and Fig. 6 showing the latch open.

By using a set of needles, as is done in a knitting

machine, a series of loops are formed at every course, and on the next course new loops are drawn through these, thus interlocking them and making a uniform web.

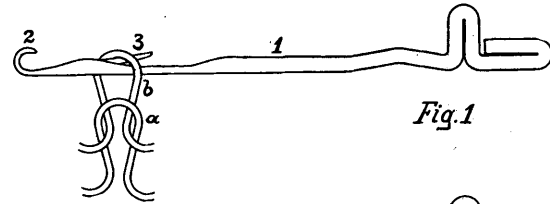

Fig. 1

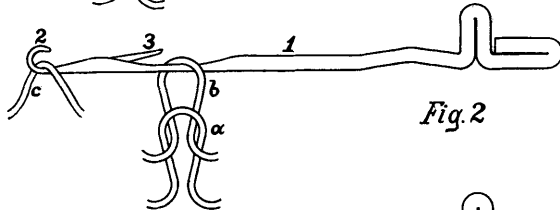

Fig. 2

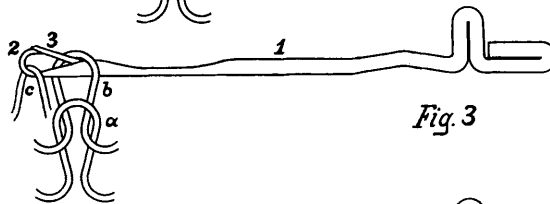

Fig. 3

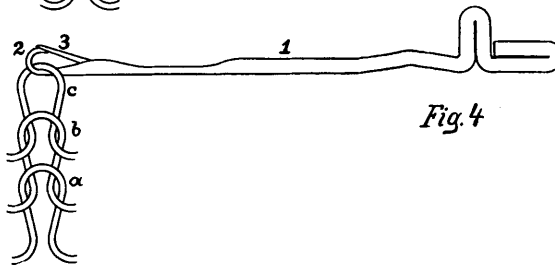

Fig. 4



Fig. 5

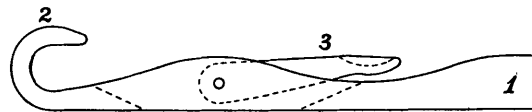
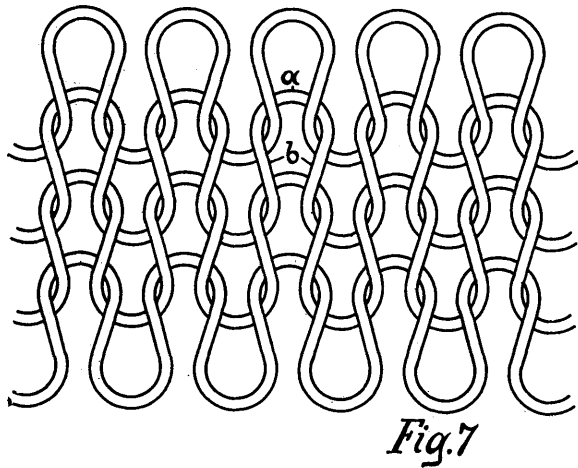

Fig. 6

This system of knitting with one set of needles will produce a "plain" stitch web, a diagram of a portion of which is shown in Fig. 7. It will be noticed that all of the loops *a* of the stitches are on the back of the web. In a knitted fabric however the loops are straighter than they are round, as shown in the dia-

gram, hence they produce a smooth and even surface. The sides or converging portions *b* of the stitches are



course, taking the place of the loops of yarn *b*, and the procedure is repeated.

The appearance of the web made with two sets of needles is different from that made with one set and is known as the "rib" stitch. A rib fabric is characterized by the fact that each side presents a similar appearance, that is, each side contains rib lines with a small space between each rib line. The rib lines on one side of the fabric come opposite to the spaces on the other side, which can be readily understood by referring to diagram Fig. 12, which represents a portion of the web. It will be noticed that every alternate loop *a* horizontally, is on the back of the web and therefore the converging parts *b* of the stitch will be on the face and make vertical rib lines with the successive stitches drawn through them. The loops *c* of the stitches, between those just referred to, are on the face of the web and consequently the converging parts *d* of the stitches will be on the back and form rib lines there. As the loops on both sides of the web form smooth places, it will readily be seen that by the stitch thus explained, these smooth places occur just opposite to the rib lines on the other side of the web, and also come between the rib lines on the same side of the fabric. Owing to the elasticity of this style of web, it is used for making tops for half hose, wrists of undershirts, etc. The stitch thus explained is known as the 1:1 rib stitch. Other varieties of this stitch are derived by combin-

all on the face of the web, and being close together in the fabric, will form a rib or raised line for every vertical row of stitches, said raised lines being close to each other.

Owing to the smooth inside surface of the web produced, this style of stitch is used almost exclusively on fabrics worn next to the body, such as underwear, stockings, etc.

The Rib Stitch: The operation of knitting by means of two separate sets of needles is best shown in connection with Figs. 8, 9, 10 and 11, which are diagrams representing the four principal positions which the needles occupy during the making of the stitch. The action of the needles is similar to the one already explained, and the two sets work in conjunction with each other. Only one needle from each set is shown, and the web produced is shown twisted out of line, in order to see the stitches to better advantage. In the illustrations, 1 and 2 indicate the body of the vertical and horizontal needles, respectively. 3 and 4 are their respective hooks, and 5 and 6, their latches. Each needle makes a stitch from the same yarn, as shown by the loops made from the yarn *b*, yarn *a* having been previously deposited and stitches formed. Fig. 8 is the normal position of the needles and loops, in which it is seen that the loops of the yarn rest on the back turned latches of the respective needles. These needles are, at the proper time, moved upwardly and outwardly and the loops rest behind the needles, as shown in Fig. 9. At this time, the yarn carrier deposits the course of yarn *c*, which rests on the projecting ends of the horizontal needles. Then the vertical needle 1 starts downwardly, as shown in Fig. 10, and has its hook 3 catch the yarn *c*, as deposited on the horizontal needles, and draw a loop. Just after this, the horizontal needle 2 draws inwardly and catches the same yarn in its hook, and as the two needles continue to move away from each other, the respective loops, resting behind the latches, close said latches by coming under their back turned ends, thus enclosing the new loops of yarn *c* in their hooks, and having the loops which are resting on the needles free to be cast over their hooks when said needles have moved sufficiently far. This position is shown in Fig. 11, where the needles have moved downwardly and inwardly, respectively, as far as possible, thus casting off the loops of the yarn *b* and making stitches. The needles then assume again the positions shown in Fig. 8, the loops of the yarn *c*, of

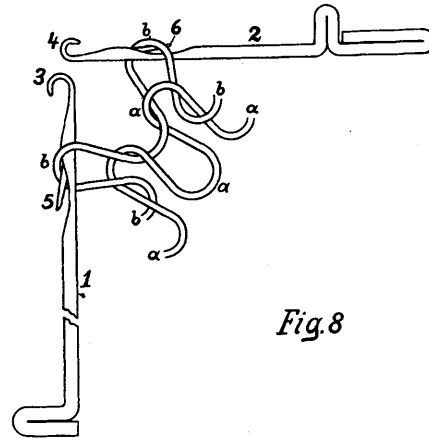

Fig 8

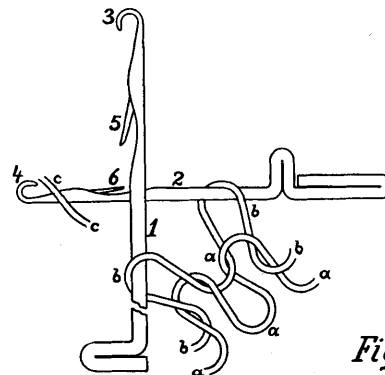

Fig 9

ing the action of the two sets of needles either 2:2, 3:1, 4:1, etc., by what we mean that for instance

with the 2:2 rib stitch, 2 rib lines alternate with 2 smooth spaces on either side of the fabric, the rib lines on one side of the fabric being directly opposite the smooth spaces on the other side of the fabric. It will be readily understood that in order to produce this stitch, two needles from one set must be placed side by side to alternate with two needles of the other set.

In order to produce a 3:1 stitch, three needles of one set must be placed side by side to alternate with one needle of the other set. The fabric produced will, of course, show a predominance of rib on one side and smooth portion on the other. It thus will be seen that the varieties in rib stitches may be obtained by simply arranging the two sets of needles according to the stitch desired.

The Tuck Stitch: This stitch is derived from the rib stitch, and forms the third foundation stitch, the plain and rib, as previously explained, being the other two. The tuck stitch is made from two sets of needles, and on the same machine as used for the rib stitch, by actuating certain cams. With the rib stitch, each loop on each needle is cast off after every course of yarn has been deposited in the hooks, as was explained, while with the tuck stitch, the loops on the vertical needles are cast off after every course of yarn has been deposited, but the loops on the horizontal needles are only cast off after every other course, thus making two loops to be cast off at the same time, instead of separately, in turn resulting in half the number of stitches being made by the horizontal needles, as are made by the vertical needles.

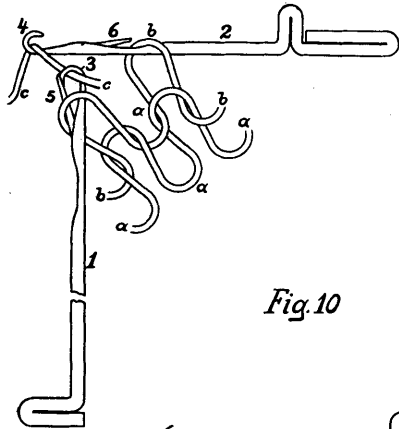

Fig.10

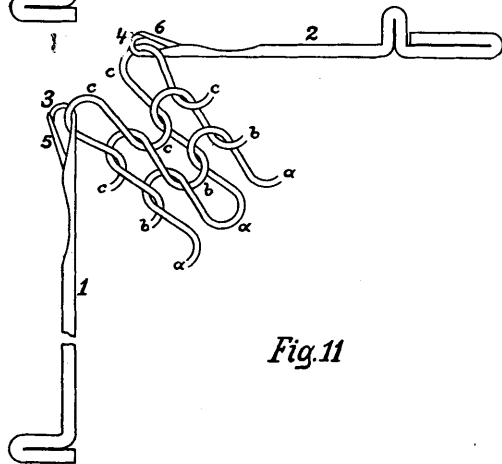

Fig.11

Since both loops are always cast off of the needle with only one loop remaining in the hook of the

M

needle, only one loop forms a stitch, the other simply being bound in with the stitch.

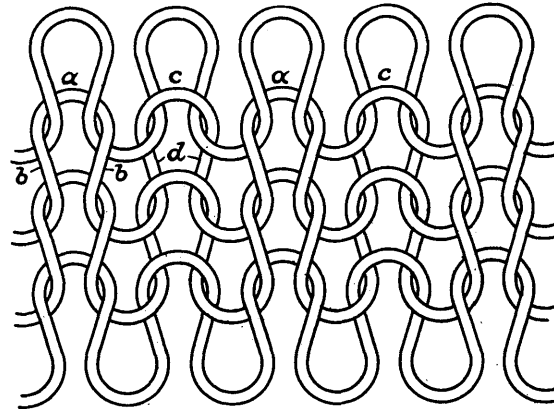

Fig.12

A diagram of a portion of a web made with the tuck stitch is shown in Fig. 13, from which the method of interlocking the loops is easily seen.

In the diagram, the stitches *a* are made by the vertical needles, therefore the loops are on the back of the web as in the rib stitch. The stitches *b* are the tuck portion and contain two loops cast over one stitch, said loops being on the front side of the web, indicating that the stitches were made by the horizontal needles. This style of stitch gives wider fabric than the rib stitch, and is used a great deal for making ladies' underwear in connection with the rib stitch, the latter being used when knitting the waist portion of a fabric, and also for the wrists or ankles of fabrics.

As previously mentioned, the stitches explained comprise what is termed the three foundation stitches and are found separately or combined in all knitted fabrics, either in the original form or a modification of them. Different combinations of stitches produce varied effects in the fabric, and variations of the stitches can be made which produce more or less fancy effects. On special machines, made for the purpose of producing fancy effects only, an almost unlimited variety of fabrics can be knitted, and it might be said that the range in knitting is practically endless.

Mock Rib Stitch: Again, derivations of a foundation stitch may be used for regular work, as, for example, the mock rib stitch. As its name indicates, it is used in place of a rib stitch, because it can be knitted on the same machine as the plain knit stitch, whereas the rib stitch requires a rib machine. This, of course, saves an outlay of rib machines and is done more in machines using spring beard needles than those using latch needles.

SPRING BEARD NEEDLES.

These needles differ materially from the latch needles in their method of operation, although the same styles of stitches are produced on them. The chief difference between the two styles of needles is in their hooks, which necessitates entirely different operations in order to produce a stitch, which in turn must be obtained by differently constructed machines. In making stitches on the latch needles, it is the separate movement of each needle which performs the operation of knitting, said needles working in a limited space, while with spring beard

needles, said needles do not move separately, but revolve bodily with the cylinder on which they are fastened. Their spring beards have to be actuated and the loops of yarn have to be moved on the needles by means of special wheels, suitably placed on the machine.

The method of making a stitch with spring beard needles is shown in the illustrations, Figs. 14, 15 and 16. In the same, 1 indicates the body portion of the needles, having spring beards 2, made at the top ends to form hooks. The portion of the body of the needle just under the end of the spring beard is slotted out, so that the end of said spring beard may enter it when pressed against the body of the needle. This makes a smooth surface from the body of the needle to the spring beard and allows a loop to pass more freely when the same is to be cast off. Fig. 14 shows the needles with work on them and in condition to receive more yarn, the course *a* having been completed, while the course *b* is resting in the hooks of the needles. Yarn *c* is shown deposited on the outside of the hooks, but the former only remains in that position for a moment, since it and also the loops of the yarn *b* are moved down on the needles, the loops *b*

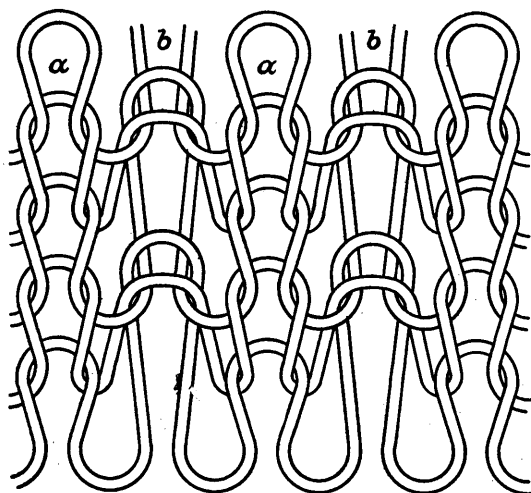

Fig. 13

resting on the needles as shown in Fig. 15, while the yarn *c* goes up under the spring beards of the needles and rests in the hooks. This movement is made by means of a special wheel or burr, as will be mentioned more in detail later on, in the article on the "Spring Beard Needle Circular Knitting Machine," said burr being situated on the machine. The casting off of the loops of yarn *b* now begins, and to do this the spring beards are pressed against the body of the needles and the loops *b* moved upwardly over the ends of the depressed spring beards, as shown in the side view of a needle in Fig. 16, and are then again acted upon by a burr which casts them over the tops of the needles and over the yarn *c*, thus making it into loops. This last position is shown by means of the front view in Fig. 16, and the needles are again ready to receive yarn as soon as they come to the feeding arrangement. A continuation of these operations produces a plain knit fabric, the appearance and construction of which has been previously explained.

Having thus given a concise, but at the same time thorough, illustrated description of the principles of knitting, we next will take up the most prominent makes and varieties of knitting machinery in this

country, starting with such as use the latch needle and quoting the spring beard needle knitting machine, later on, and closing the descriptive matter on the subject of knitting with the machinery and processes relating to the trimming, *i. e.* finishing of knit goods.

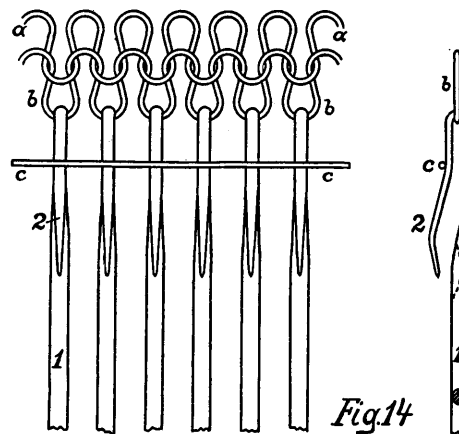

Fig. 14

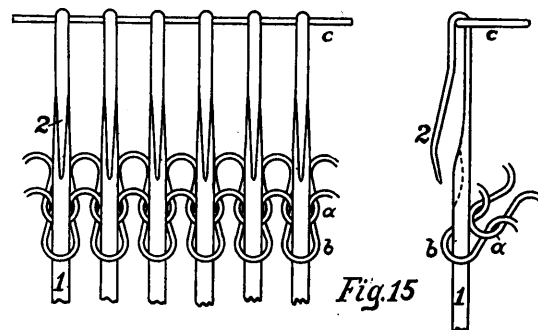

Fig. 15

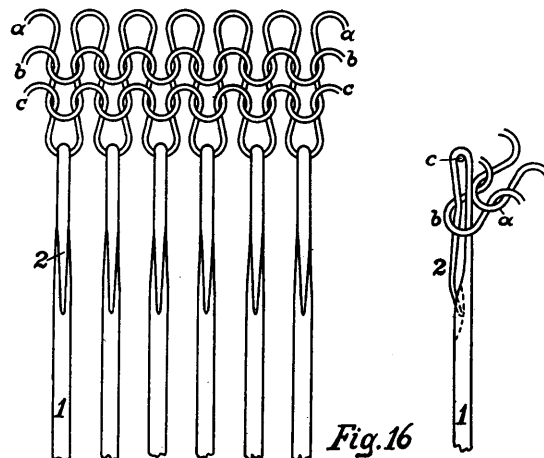

Fig. 16

A most important item for knitting, with reference to quality and quantity of work produced are perfectly wound bobbins or cones, for the needles to take their supply of yarn from, and which subject has been explained in the chapter on "Winding."

BRINTON'S RIB TOP MACHINE.

This machine, as its name indicates, is used for knitting the tops for half hose and is known as a full automatic rib machine. As will be seen from its perspective view, shown in Fig. 1, a single feed is used, that is, one yarn carrier is used to feed the yarn, from one, two or more cones, as required to produce the proper weight of fabric to the needles.

The machine consists essentially of a head motion for performing the knitting operation, a pattern motion for producing the welts and slack courses in the desired positions on the plain rib tops, and a take-up motion for giving an even tension to the knitted fabric, with any length of stitch used in its production.

The Head Motion contains two separate sets of needles, but which work in conjunction with each

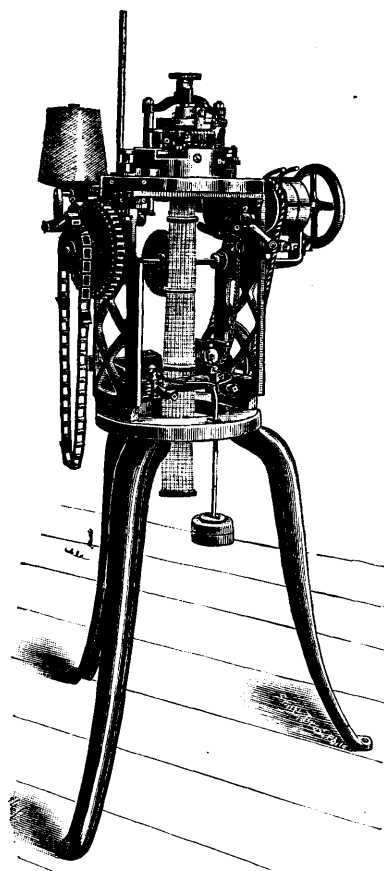

Fig. 1.

other, the needles being placed alternately in the proper working positions in the machine. One set of needles, known as the *Dial needles*, are placed horizontally in the head and rest in grooves in the dial plate, said needles being placed radially from the centre of the dial plate. This dial plate is circular, being provided with radial grooves on its top surface for holding the dial plate needles, and is held in position in the machine by having a shaft extending vertically through it with a collar attached to the lower end. The dial plate is prevented from turning, by means of two projections on the side of the plate, which rest

in slots provided for them on the frame, and hence the dial plate needles receive no rotation. Situated directly above the dial plate is the dial cap, which is secured to the shaft extending from the yoke and thus it receives its rotation. The under side of the dial cap is made with a cam groove for receiving the upwardly projecting shanks of the dial plate needles, said cam giving the required horizontal movement to the dial plate needles for knitting.

In order to explain the operation of the dial cap cam on the dial plate needles, and also to show the proper outline of the cam groove, Fig. 2 is given, which is a view taken from the under side of the dial cap. The cam revolves in the direction of the arrow and the dial plate needles are operated by the inside surface of the groove. The cam A is made

movable, being centred at B, in order to change from the plain stitch to the welt.

The method of making a stitch may be seen by examining the outline of the cam groove.

First, consider position as indicated by 1 on the cam groove. It will be noticed that at this point the groove is beginning to curve outwardly from the centre of the dial cap. As the motion of the needles is controlled by the cam groove, the needle acted upon by this point of the cam will be moved outwardly until the point 2 acts upon it. During this time the latch of the needle, which was closed by the last inward movement of the needle, is opened by being forced against the stitch in the hook of the needle, said stitch, when the point 2 acts, resting on the needle behind the open latch. When the latch was opened by the stitch, the yarn carrier, situated on the dial cap, deposited new yarn into the open hook of the needle, the yarn carrier being placed on the dial cap so as to deposit yarn at a point just in front of the point 2. From the point 2 to point 3, the needle is drawn inwardly in order to have the stitch, as resting behind the latch on the needle, slide over the hook (thus closing the latch), and be cast off, thus completing a single knitting operation by the dial needle. From the point 4 to point 1, the needle is at rest, when it again performs the same operation as described and makes another stitch. It will be noticed that only one needle has been referred to in connection with the operation, although the cam, as it revolves, acts upon each needle in succession in the same manner as described.

The movable cam A, as shown in full lines, is in the position for giving the plain stitch, while the position shown in dotted lines is for making the welt. The cam is operated from the pattern wheel through pin G (corresponding to pin G in Fig. 6). The welt is made by having the needle move outwardly only half way in order that the stitch in the hook may just open the latch without sliding behind it, so that the yarn carrier may deposit another stitch, thus having two stitches in the hook when the needle is drawn back by the cam. This half way movement of the needle is obtained by having the cam A move only half way in, which is controlled by the pattern wheel. Before the cam A comes around again to the needle, said cam, that is, the groove, has been moved entirely in, so that the needle is not moved outwardly and thus loses a stitch, this being repeated again, in order to make two lost stitches which form the welt. It will be understood that the cylinder or vertical needles, not yet referred to, are always in operation during this change of working by the dial plate needles.

The plate C is made adjustable with screws and is used to regulate the length of stitch taken by the dial needles. For a long stitch, the nose D is set farther in towards the centre of the dial, so that the needles will be correspondingly pushed farther in and thus draw a longer length of yarn with them, in this manner producing the longer stitch. By setting the nose D outwardly, a shorter stitch is obtained, as in this case, the needles do not go in as far and consequently take less yarn for a stitch. The rings E and F are used to prevent any possibility of the needles flying out when they should be at rest.

The set of needles used in connection with the dial needles are known as the *Cylinder needles* and are placed vertically in the grooves of a needle cylinder for holding them. The body of the needles extends below the dial plate, in fact, the needles go entirely below said plate when they are at rest, and only slightly above when in the highest position, in order to catch the yarn which was laid on the dial needles. The cylinder needles are placed so that each needle rises between two dial needles and draws

down enough yarn to allow of a stitch by a needle from each set.

These cylinder needles, as was intimated, receive a vertical movement, in order to perform the knitting operation, said movement being obtained by means of a cam groove, placed on the cam cylinder which revolves about the needle cylinder, the cylin-

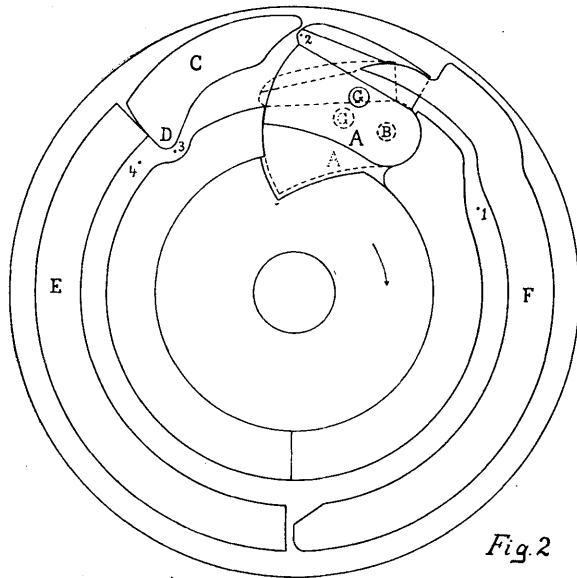

Fig. 2

der needles having projecting shanks near the bottom of their lengths, which run in the cam groove. The cam cylinder is attached to the cylinder needle cam ring, which receives a positive rotation, and through this ring the cam cylinder and also the dial cap, containing the dial cam, are given a rotary movement.

A development of the cylinder needle cam is shown in Fig. 3, that is, the groove is shown in one plane, whereas in the machine it is circular, the two ends shown, forming a continuous groove on the cam cylinder.

Referring to the illustration to explain the method of operating the cylinder needles for knitting, 1 indicates the point which starts the needle upwardly to open the latch of said needle, the stitch in the hook in this instance acting to open the latch in the same manner as with the dial needles. When the point 2 acts upon the needle, said needle goes to its highest point with the latch open and the stitch resting just below the latch on the needle. Before the needle starts down again, the yarn carrier has deposited the yarn on the projecting dial needles, so that the cylinder needle in coming down catches the yarn in its hook to form a new stitch when the stitch in back of the latch closes said latch and is cast off.

Point 3 indicates the part of the cam for casting off the stitch by bringing the needle to its lowest position. This movement of the needle corresponds to the inward movement of the dial needle, that is, the stitch below the latch, when the needle goes down, slides over the latch, thus closing it and then slides entirely off of the needle. From point 3 to point 4 the needles rise to a resting position, attained at point 4, and in which position they remain without the aid of a top guard until arriving again at point 1, thus completing the cycle of operation for one stitch.

The loose or slack course is made in the fabric by means of these cylinder needles. A slack course is

simply a long stitch and is obtained through the cam A. This cam is made vertically movable and is operated from the pattern wheel as will be explained later. By moving it downward, a longer stitch is obtained, because the needles are drawn down farther and consequently take more yarn. After the long stitch is made, the cam A is raised to its normal position and the plain stitch is again made. The cams B and C are used as guards to prevent the needles from flying upwardly and opening the latch, and consequently losing a stitch, when they should be partly down with the latch closed.

It may be mentioned that the dial plate cam is set so that the point 2 leads the point 2 of the cylinder cam a short distance. This is necessary in order that the cylinder needles shall descend slightly in advance of the dial needles drawing inwardly, in order that said cylinder needles may catch the yarn as resting on the projecting dial needles before it is drawn inwardly by said dial needles.

Pattern Wheel. This wheel, as its name indicates, is used to produce the pattern, that is, to put the welts and slack courses in their proper positions in the half hose tops. Fig. 4 is a side view of a pattern wheel with operating levers, said wheel being driven by the ratchet teeth on its circumference, as will be subsequently explained. The figure also shows the pattern chain cylinder which is positively driven from a wire-point clothed wheel in contact with the moving fabric as the latter is being drawn down by the take-up motion. There are three rows of screw holes around the pattern wheel, the holes being made radially over each other and receive screws according to the pattern desired. These screws actuate a vertically movable bob pin through levers, which in turn actuate the movable cams on the dial plate and on the cylinder cam through lever connections. By placing a screw in hole No. 1, a loose course is made by moving the cam A, Fig. 3, on the cylinder cam lower, so as to get a corresponding movement of the cylinder needles. A screw in hole No. 2 of the pattern wheel will bring both cams to their normal positions and thus produce plain work. No screws in any of the three holes will make the tuck stitch for the welt, that is, the movable dial cam will go in half way and cause the double stitch.

A screw in hole No. 3 will cause the dial needles to remain at rest, that is, in an inward position, so that they will lose the necessary stitch for the welt.

In order to show more in detail the connection between the pattern wheel and the movable cams,

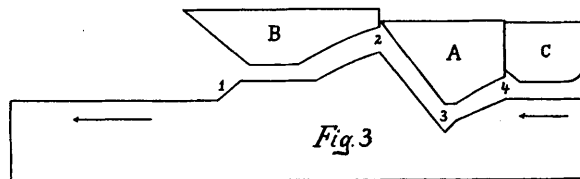

Fig. 3

diagrams Figs. 4, 5 and 6 will be referred to. Fig. 4 will be used to show how movement is given to the bob pin. Fig. 5 shows the diagram of the levers, as actuated by the bob pin, for operating the movable cylinder cam; and Fig. 6 shows a diagram of the levers, as actuated by the bob pin, for operating the dial cam.

Referring to Fig. 4, the pattern chain cylinder A is fast on the shaft B which is driven through gears and a measuring wheel from the take-up of the knitted fabric, which is clearly shown in Fig. 1. The pattern wheel C is loose on the shaft B and is driven by the reciprocating pawl D. As was mentioned, on one side of the pattern wheel, the pattern screw pins

are placed in rows of holes 1, 2, 3 respectively, while on the other side, a screw pin is used, being placed in row 2, in order to throw the pattern wheel out of action. This is done by having the pin come under the arm E and raises it, which in turn comes under the pawl D and raises it out of contact with the ratchet on the pattern wheel C. Before the pawl D can

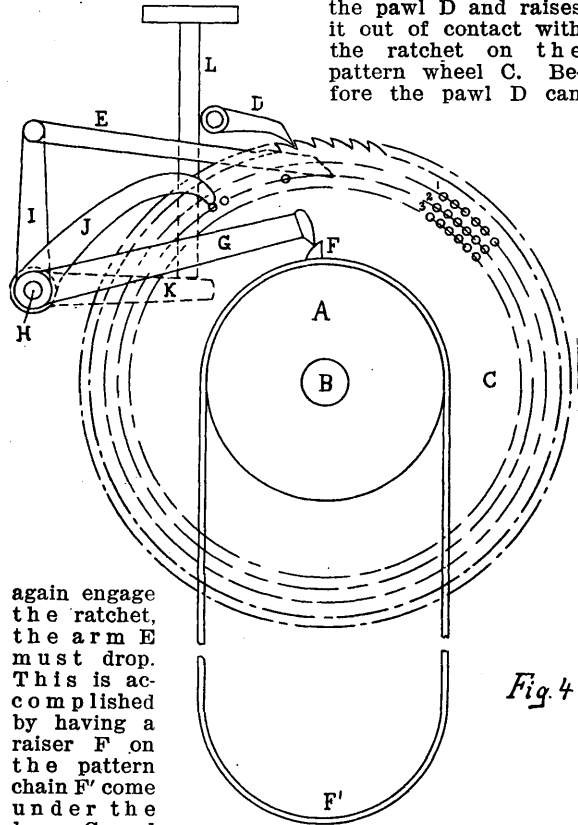

Fig. 4

again engage the ratchet, the arm E must drop. This is accomplished by having a raiser F on the pattern chain F' come under the lever G and raise it. This lever is centred at H and has an upwardly projecting arm I, which is attached to the rear end of the arm E, so that when the lever G is raised, arm I goes slightly backwards, carrying the arm E with it, thus taking it off of the screw pin which previously raised it, and allowing the pawl to again engage with the ratchet.

Centred at the same point H, but not connected with the lever G, is an arm J with its other end resting on the pattern screw pins of the pattern wheel C. On the same collar with this arm J is the arm K which supports the bob pin L. By placing the pattern screw pins in different holes on the pattern wheel, when it revolves, the arm J is given an upward or downward movement to correspond to the placing of these pins, and through the arm K, the bob pin L is raised or lowered accordingly.

It was mentioned that when a screw was in the top hole of the pattern wheel, the movable cylinder cam was operated to make the slack or loose course stitch. Referring to diagram Fig. 5 for the details of this operation, this motion is placed on the cam cylinder and consequently revolves with it. The diagram shows more the action of the parts on each other than their relative positions on the cylinder. A top finger A projects from the cylinder and is fastened to a rod B, the lower end of which carries a small gear b, which meshes with a similar gear c on the end of the rod C, this rod C also carrying a projecting finger D situated just under the finger A. Secured to the top of the rod C is a lever E carrying

at its end a projecting screw F. As the cylinder revolves, the finger A strikes against the bob pin (previously explained) and is pushed in. This action gives the rod B a left hand movement, the rod C a right hand one and consequently the lever E is moved inwardly, causing the projecting screw F to come in contact with an inclined surface plate G and pushes it down against the action of the spring H which is on the screw I connecting the plate G with the movable cam J. By thus lowering the cam J with this movement, the desired loose course stitch for the fabric is obtained. To get said cam to its normal position, a screw pin is put in the second hole on pattern wheel, which causes the bob pin to be struck by the finger D and thus throw the projecting screw F off of the inclined surface plate G, and when the spring H raises said plate and the cam J to their normal positions.

The method of operating the movable dial cam is similar to the one just described and is shown in diagram Fig. 6. As was mentioned, the dial cam is used to make the welt, and first has to go in half way for one stitch and then entirely in for two stitches. A finger A is used for the half way movement, while a longer finger B makes the entire movement. This motion is also situated on the cam cylinder. A spring controlled rod C has a stop piece D at the bottom, which is held first by the inner end of the finger A and when that is released, by the finger B, the tendency of this stop piece D being to revolve past the fingers. Secured to the top of the rod C is a lever E which is connected at its other end to a link F, the other end of said link being attached to a peg G projecting up from the movable dial cam H (see A, Fig. 2) as pivoted at I.

When the bob pin is struck by the finger A, the stop piece D is released until it comes to the finger B, the movement of the rod C being transmitted, through the levers shown, to the cam which is moved half way in to give that stitch. On the next revolution of the cylinder, the finger B comes against the bob pin (see L, Fig. 4) and the stop piece D is entirely released, thus giving a rotary movement to the rod C which in turn, through the levers shown, moves the cam H entirely in and causes the lost stitch. When two stitches have been lost, the cam is brought to its normal position by having a finger J as attached to the rod C, strike against the bob pin and cause the rod C to revolve in the opposite direction to its first movement. This causes the levers mentioned to move the cam H out to its normal position for plain knitting. It will be seen from the foregoing explanations that it is necessary for the pattern

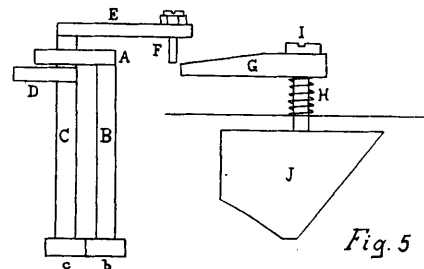

Fig. 5

wheel to revolve when putting in the special stitches, but for the plain stitch, its use becomes unnecessary.

The Take-Up for the knitted fabric may be best explained by referring back to Fig. 1, the take-up being shown near the frame stand. It consists principally of a swinging frame carrying a pair of fluted rolls between which the fabric is held. These rolls are geared from a shaft having a grooved pulley at

tached to it. Another grooved pulley on the driving shaft of the machine drives the bottom pulley through a rope when the tension is sufficient, because the bottom pulley is carried by the swinging frame. The rolls are weighted by weights shown in front of the machine. This weight acts to put tension on the fabric and as the latter is being produced, the weight descends, carrying the swinging frame with it. When the latter has descended far enough to cause the rope to grip the pulleys, the fluted rolls are revolved through gearing from the pulley, and thus work themselves up on the fabric, carrying the swinging frame with them. As soon as the rope becomes slack again from this movement, the revolutions of the rolls stop and the

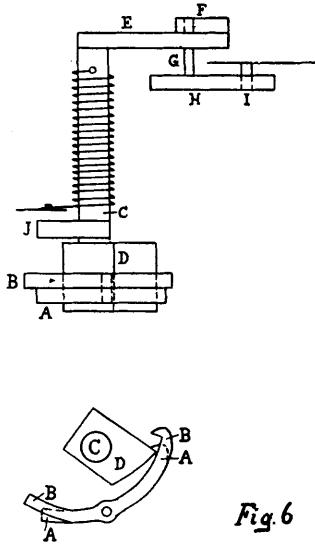

Fig. 6

swing frame begins to descend again. In this manner a constant and even weight is put on the fabric, which in turn will give a smooth fabric.

Stop Motions are also provided on the machine, one for controlling the feed of the yarn and another for controlling the delivery of the fabric, in either instance the absence of material causing the machine to stop with the brake applied. These stop motions, *i. e.* their construction and operation, form later on the subject for four special articles; said stop motions having nothing directly to do with the principle of knitting of the machine, their chief function being to insure a perfect fabric, reduce waste of yarn to a minimum and production of the machine at the same time to its maximum capacity. (H. Brinton & Co., Philadelphia, Pa.)

BRINTON'S RIB TOP MACHINE, WITH KNEE AND ANKLE SPLICE.

This machine is of the same pattern as the Rib Top machine previously explained, with the exception that an extra attachment is provided for splicing, so that the explanations given for the different motions of the latter machine will apply also to this machine with Knee and Ankle Splice attachment, and consequently only an explanation of the splicing attachment is necessary.

This machine is used principally for making Misses' Ribbed stocking legs with reinforcements at the knees and ankles, however, Leggings, Wristers, etc., may also be made on the machine by changing the pattern wheel and length of pattern chain.

In order to make a splice in the fabric, *i. e.* produce a heavier and stronger section in the fabric, an extra thread is fed to the single yarn carrier of the Rib Top machine at the proper time. After making the splice, said extra thread is withdrawn from feeding. When this extra thread is fed to the yarn carrier for insertion into the fabric, the rib stitch which is being made must be longer than for a single yarn, as otherwise the fabric would be too tight. For this reason, the movable cylinder cam must be lowered in order to make the slack course stitch during the time of splicing.

A special attachment for making the splice is shown in the accompanying illustration Fig. 1, which is a side view with the parts shown in the position when the extra thread is being run. The attachment is secured on the cam cylinder by screwing the post A into the cam cylinder and by having the piece B screwed to the side of said cylinder, thus having the attachment revolve with the cam cylinder, it being placed radially from the hole in the yarn carrier which is also carried by the cam cylinder. The device consists principally of a pair of jaws C and D which are pivoted on top of the post A, the movement of said jaws being similar to a pair of scissors.

The extra thread to be inserted into the fabric with the regular yarn is passed between the ends E of the jaws C and D. These ends are held normally in contact with each other by means of a rod F being passed through the jaws C and D on the opposite side of the pivot from the ends E, and having a spring placed on one end of said rod to press these ends toward each other. By having the ends E thus in contact with each other, the thread is gripped by them and prevented from being delivered until released. Secured to the piece B is a projection G in which a lever H is centred at I, this lever H extending up and between the outer ends of the jaws C and D and having a portion J on each side near the top beveled in order that it may more easily spread the jaws C and D when pushed in. To also assist in this, the inside surfaces of the jaws are beveled near the ends. The top end of the lever H has a thread guide K through which the yarn is threaded in its passage to the ends E. A pin L is situated on the lever H about half way down its length, which is directly under a beveled side of a lever M as pivoted at N, the other end of said lever carrying a screw O which presses against the inclined surface plate G shown in Fig. 5 of Brinton's Rib Top Machine (see page 195) at the proper time, thus lowering the movable cam J in the same figure, in order to make the long stitch for the splice.

The action of the device is as follows: When the splice is called for, a bob pin is struck by the inside surface of the lower end of the lever H, thus forcing that end outwardly, which in turn forces the upper end inwardly, causing it to wedge itself between the jaws C and D, against the action of the spring on the rod F, and thus open them, which action also causes the ends E to open and free the extra thread.

The thread is now allowed to pass along with the regular thread, it being held up in contact with said regular thread by means of a wire P and held down on the other side of the ends E by a wire Q. At the same time, the pin L comes against the bevel end

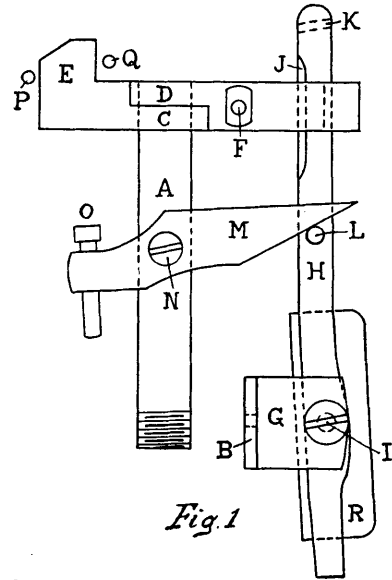

Fig. 1

of the lever M and forces it up and consequently the other end carrying the screw O down, thus making the long stitch, as explained.

When the splice has been made a bob pin comes in the path of the outside edge of lever H and throws it in and the top end out. The jaws C and D, thus being freed, come together and the ends E grip the thread. The pin L is also brought from under the lever M and the screw O releases the cam, in this way making the regular stitch again. The bob pins mentioned are controlled by the pattern wheel.

Two rows of holes are provided on the pattern wheel, but on the opposite side from the regular pattern holes, these holes being nearer the centre of the pattern wheel than the regular pattern holes. A screw in the outer row of holes will cause a lever resting on said screw to raise a specially shaped bob pin, as situated on the cam cylinder ring, which will throw the bottom end of the lever H out when it comes around and consequently the top end will move in, thus causing a feed of the extra yarn, while a screw in the inner row of holes on the pattern wheel will cause a lever to raise another specially shaped bob pin, which will in turn, as the cam cylinder revolves, throw the lower end of the lever H inwardly and the top end out, thus stopping the feed of the extra yarn as explained.

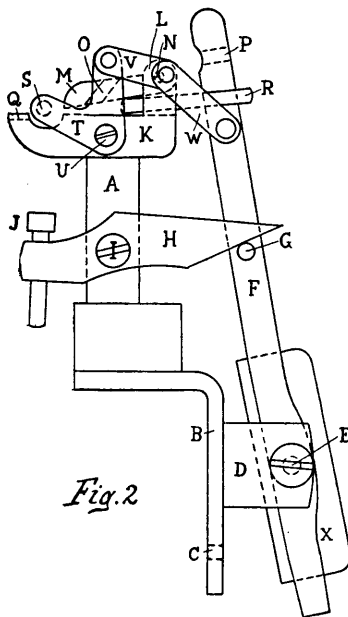

Fig. 2

the same time more positive in its action. The illustration is a side view of the device which is also secured to the cam cylinder and thus revolves with it. The device consists of an upright post A, having a flange B at the bottom, which is attached to the side of the cam cylinder by passing screws through the holes C into the cam cylinder. The flange B is also provided with a projection D which is used as a pivot at E for the lever F. About half way up the length of this lever F is a pin G, which comes under one end of the lever H as centred at I, when the lever is moved in, and consequently causes the projecting screw J on the other end of the lever H to move down and press against the inclined surface plate (G in Fig. 5,—see page 195 for it) thus lowering the movable cam J in said Fig. 5, in order to make the long stitch for the splice, this portion being identical with that previ-

ously explained in connection with the other splicer.

Situated on top of the post A (see again Fig. 2 of this article) is the yarn feeding arrangement for the extra yarn, and which consists of a specially shaped piece K, the outer end of which is made with an upwardly projecting arm L for holding one end of the yarn guide M as pivoted at N. This yarn guide M is made with a slanting hole O through which the extra yarn passes from the guide eye P in the lever F to the guide Q as situated on the piece K. Resting on the top side of the piece K and just under the yarn guide M is a slide R, the outer end of which is made to fit over the lever F and hence it receives a forward and backward movement to correspond to the movement of the lever F. A forward movement of the slide R will put said slide in the position shown in the illustration, that is, it comes under the yarn guide M and raises it slightly, against the pressure of a spring which tends to hold one end of the guide M in contact with the top surface of the piece K. It is this motion which produces the feed of the extra yarn, for in this case the extra yarn which is resting in the guides P, O and Q was gripped by having the yarn guide M pressing against the top surface of the piece K with the yarn between them, and when the yarn guide M is raised by the slide R, the yarn is released and free to be carried along by the regular yarn in the yarn carrier to the needles. In order to insure enough friction between the regular yarn and the extra yarn, to be able to carry it forward to the needles, when said extra yarn is free to move, a pin S is provided, which is secured in one arm of the elbow lever T as centred at U. The regular thread is passed behind and under this pin S in its passage to the yarn carrier, and by depressing the pin S said thread is brought down into contact with the extra thread, this contact being sufficient to cause the extra thread to travel along with the regular thread and be fed with it. The downward movement of the pin S is obtained by having the other arm of the elbow lever T connected to the lever F through two links V and W, so that as said lever F moves in, the vertical arm of the elbow lever T is moved in and consequently the other arm carrying the pin S is moved down.

It will be seen from the foregoing explanation, that when the top part of the lever F is moved in, the extra yarn is fed to the needles, thus producing the splice, and when it is moved outward, the slide R is withdrawn from under the yarn guide M which then falls under the action of a spring and grips the yarn, thus causing it to break out at the needles and cease to be fed. At the same time the pin S is raised, bringing the regular yarn out of contact with the extra yarn, also the lever H is released, thus allowing the movable cylinder cam to rise again to its original position for the plain rib stitch. The inward and outward motions of the lever F are controlled by the pattern wheel, in the same manner as explained in connection with the previous splicer. (H. Brinton & Co., Philadelphia, Pa.)

BRINTON'S AUTOMATIC SLEEVEE.

While the Automatic Sleevee is in the same class with the Rib Top Machines which have been explained before, and its motions are similar, yet it differs from them materially in that it is a two feed machine, that is, two yarn carriers are used and consequently the cam outlines for the two sets of needles are different from those shown for the single feed Rib Top Machines.

Sleeves for underwear are the principal articles made on this machine, although it may be used for half hose tops if required, a greater production being obtained than with a regular Rib Top Machine, owing to the double feed.