



Threading

During the last 35 years complicated machines have been patented and perfected which automatically remove the empty bobbins from the carriages, place them together in a box, insert full bobbins, and thread and deliver carriages in a receptacle at the rate of 2,500 to 3,000 an hour. These have been tried with questionable results in domestic lace mills and in most mills the process is carried out by hand as described.

It is customary for every lace machine to be equipped with two full sets of carriages and three full sets of bobbins, in order that during the time one set is in use in the machine another set may be wound, pressed, threaded, and shaken to avoid the loss of time which would occur if the machine were required to remain idle while any of these processes were performed.

The manufacture of bobbins and carriages requires such care that their production constitutes a separate branch of the industry in the lace-machine producing centers. The making of these parts was first undertaken by Shepperly of Nottingham, a watchmaker. The fine touch, trained sight and habits of exact manipulation possessed by watchmakers are still the best qualifications for employment in this department.

To sum it up, to form a ground, two sets of threads are required. The bobbins which always follow the same path in the combs, and the warp or beam threads which pass in front of or behind the bobbin threads, to the right or to the left according to the action of the Jacquard on the steel bars through which they are threaded. The motifs are made up of supplementary threads held in reserve at certain moments, or intervening at other moments, either to form the motifs or to leave empty spaces on the net, and work at the same time as the warp threads.

When it is considered that it is possible to procure the intervention of the supplementary threads at moments determined beforehand, it follows that the realization of the forms of flowers, leaves or other motifs which are usual in lace, is possible also.

BOBBIN THREADS: After the carriages are threaded with the filled bobbins, they are placed in the machine, one carriage to each space in the combs. The comb bars run the entire length of the machine and face each other, one at the front and the other at the back of the threads, and comb leads, each of which is two inches in width, are screwed to the comb bars, side by side. Every comb lead contains a number of curved, thin, steel blades cast into metal, the number of blades in one comb being four times the gauge of the machine.

There may be as many as 4,000 bobbins in one machine and they do not all run out at the same time. When the whole set is removed from the machine and replaced with a new set, the bobbin threads are pulled up and laid on the porcupine roll. It is not necessary to tie in the new set. The twisting of the threads and the action of the point bars secure the loose ends to the fabric.

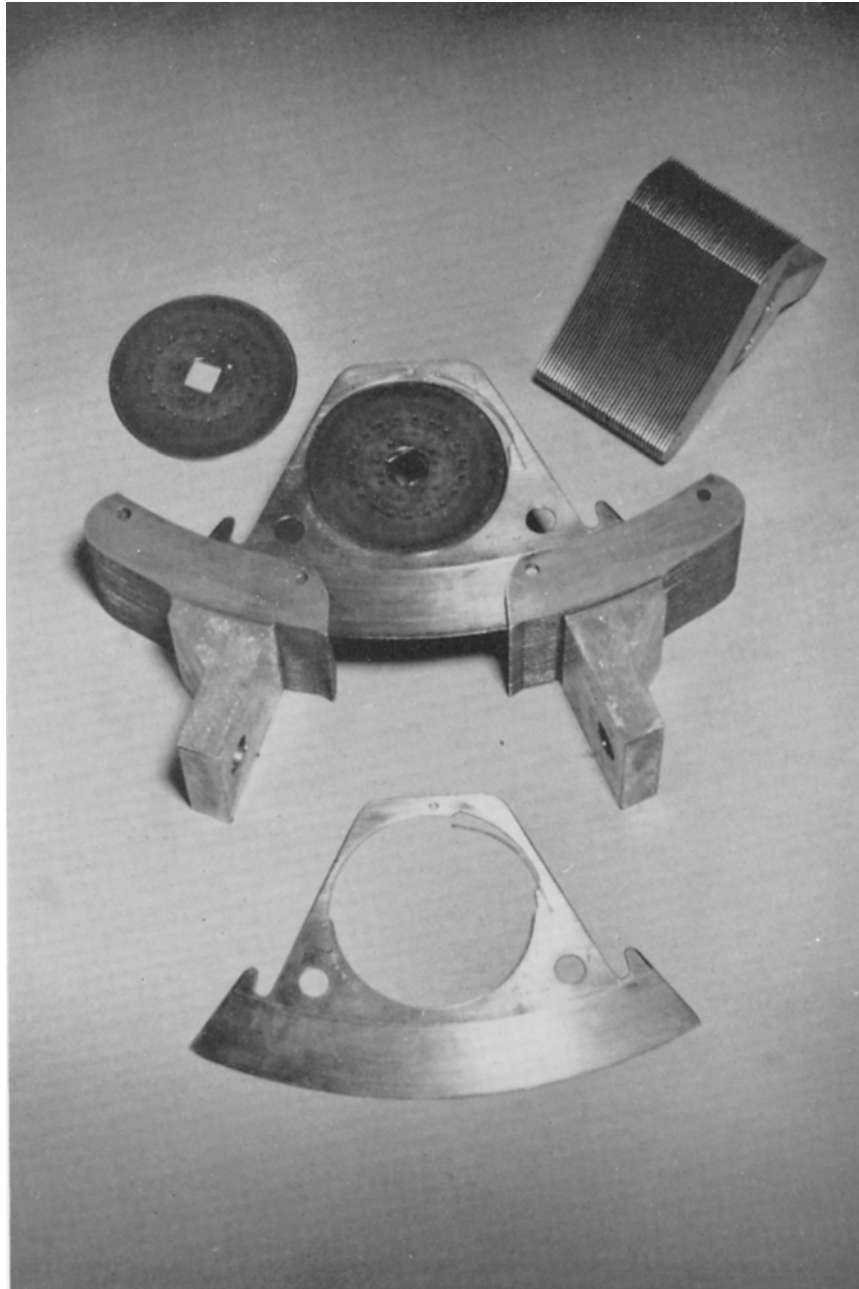

From top to bottom:
Left, bobbin; right, comb lead; center, bobbin and carriage in
position in comb lead; bottom, carriage with bobbin removed
[39]



Bobbin stripping



Entering full set of carriages and bobbins

8. Bobbin Stripping

The bobbins rejected after screening and the bobbins removed from a machine when the set starts to run out, are sent to the stripper to remove all excess yarn from the bobbins. If the end of the thread is stuck in the bobbin, it is freed by means of a small hook, which the operator inserts between the two discs of the bobbin. This operation is called "Searching". A number of bobbins are placed on a square shaft and the loose threads are fastened to a small reel, which unwind all the thread from the bobbins. The stripped yarn is waste and is used as wiping material.

The waste yarn obtained in stripping may be anywhere from 10 to 32 ounces of an average of 6 lbs. of yarn, which is wound on one full set of about 4,000 bobbins. Bobbin yarn waste runs from 10% to 30%, or an average of about 20%.

9. Entering in Machine (Warps and Beams)

The warp beams are of the length of the machine and are placed in slots in metal arms below and behind the sley. The smaller beams (independent beams), of which there may be many, are placed behind the warp-beams. The warp threads pass directly to the sley, but threads of the independent beams are passed through a metal beading or row of eyelets of looped wire and then upward through the sley in front of the warp threads.

After those threads are passed up through the sley the warp and beam threads are then entered through the steel bars which are above the sley and which are supported by brackets. The thousands of threads are passed by hand, each to a particular hole, in many individual bars. This work is performed by the twist hands and takes two men, ten days to two weeks, to "set out" a machine.

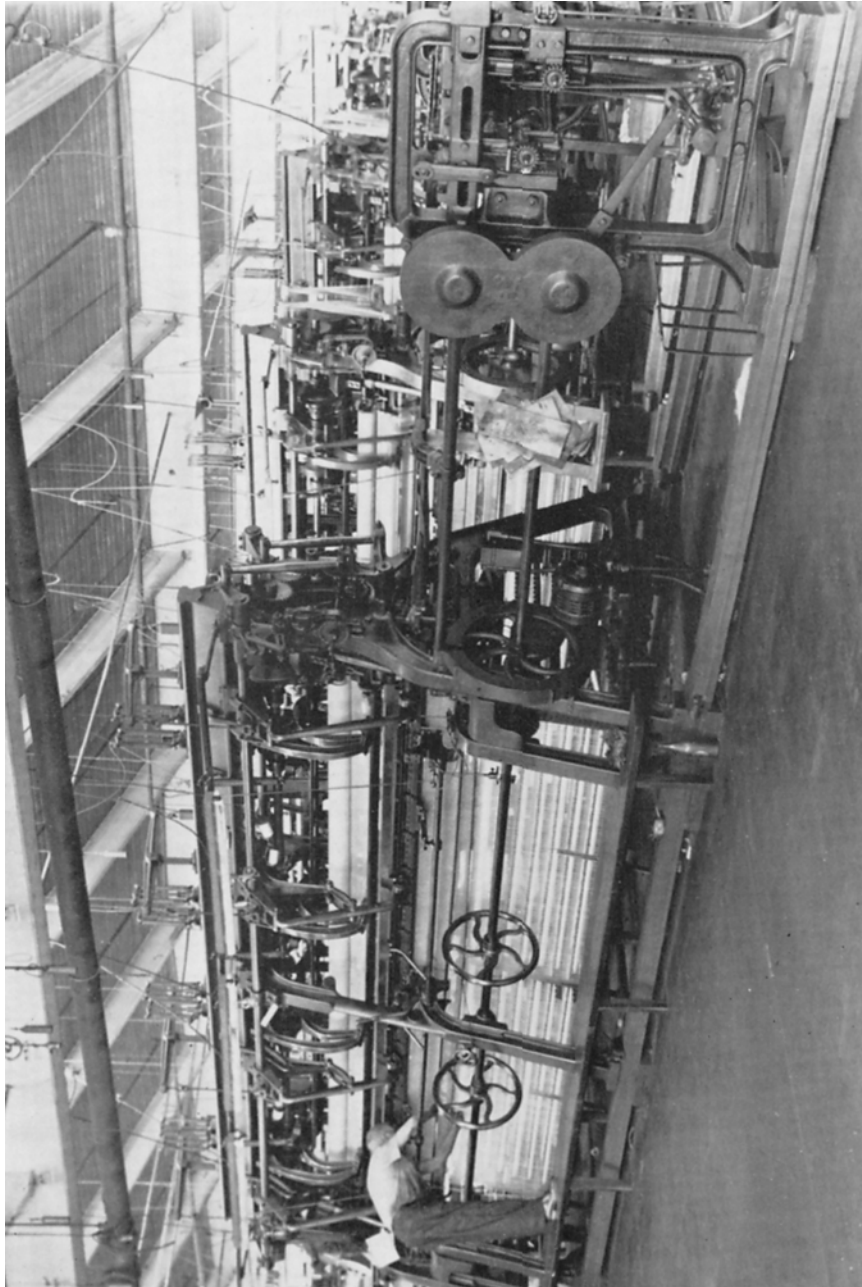

12 point, 186" Leavers Go-through Lace Machine

Theory of Lace Making By Machine

FIG. I

From a rod a weight (A) representing the carriage and bobbin is suspended by a thread representing the bobbin thread. At equal distances on each side of this thread are two other threads (B&C) representing the warp threads. If the weight "A" swings from and toward the observer and threads "B" & "C" remain stationary there will be no result.

FIG. II

Threads "B" & "C" are drawn to opposite sides while the bobbin thread "A" is behind them away from the observer.

FIG. III

The bobbin thread "A" moves forward through the crossed threads.

FIG. IV

Warp threads "B" & "C" resume their original positions and a twisting action results.

FIG. V

If the bobbin thread attached to weight "A" is under tension and the warp threads are loose the warp threads will twist around the bobbin threads.

FIG. VI

If the warp threads "B" & "C" are under tension and the bobbin thread is loose the bobbin thread will twist around the warp threads.

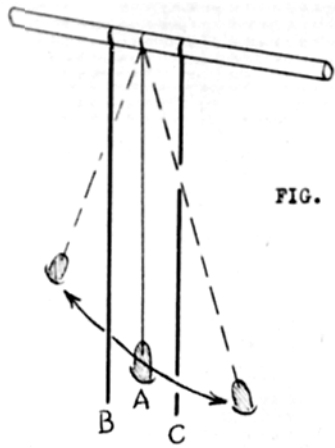

FIG. I

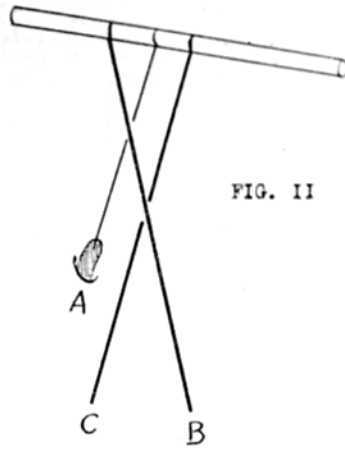

FIG. II

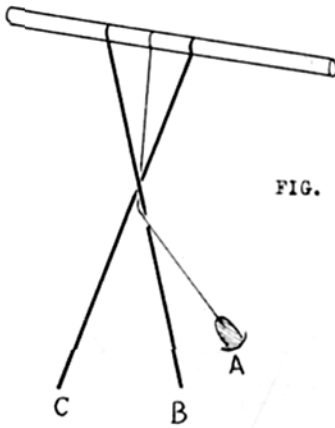

FIG. III

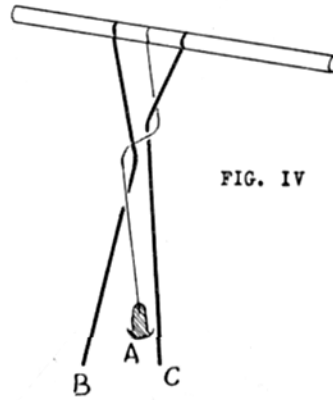

FIG. IV

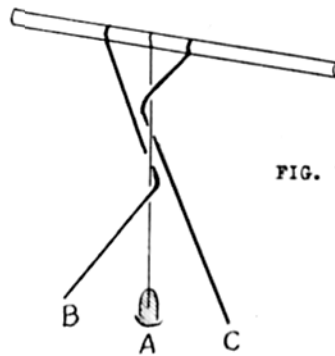

FIG. V

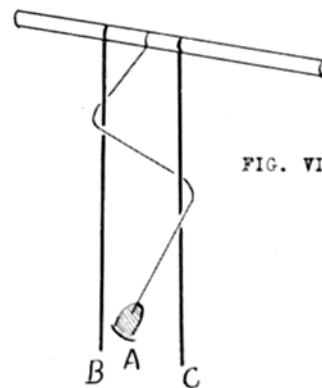
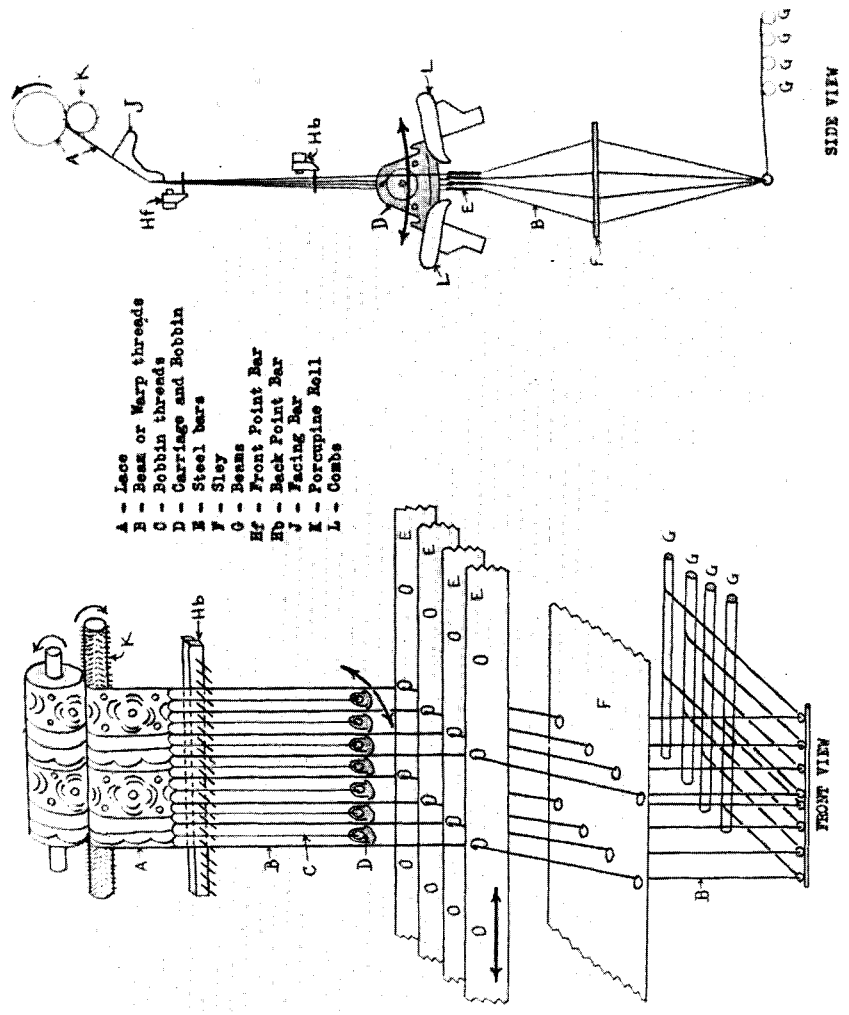

FIG. VI

Theory of lace making by machine



- A - Lace
- B - Beam or Warp threads
- C - Bobbin threads
- D - Carriage and Bobbin
- E - Sley
- F - Beams
- G - Front Point Bar
- Hf - Back Point Bar
- Hb - Facing Bar
- J - Porcupine Roll
- K - Combs
- L - Combs

Principles of Leavers lace machine

Principles of the Leavers Lace Machine

Lace is an ornamental or decorative openwork, in the making of which the ornamentation and fabric are produced concurrently by the movements and intertwisting of two distinct sets of threads — the warp and beam (B), and the bobbin threads, (C). The bobbins (D) swing like pendulums, through the warp threads, *always in the same path*, by being guided in slots of the combs (L). The steel bars (E), through which the warp ends are threaded, are actuated by a Jacquard mechanism and may move either to the right or to the left. The direction and distance the steel bars move is predetermined by the pattern.

After the carriages (D), move from front to back, the steel bars move — some to the right, others to the left. The back point bar (Hb) moves up and compresses the twists of the previous motion, to form another bit of lace fabric. Porcupine roll (K) turns enough to make room for this newly formed lace. The front point bar (Hf) moves down into position for the next motion.

The process is again repeated. However, the carriages (D) move in reverse from back to front, the steel bars (E) move to the right and to the left, the front point bar (Hf) moves up compressing the twists to form more lace fabric, and porcupine roll (K) turns just enough to make room for this new bit of lace. The back point bar moves down into position ready to compress the twists of the next motion into another bit of lace.

10. The Leavers Lace Machine and Its Operation

A lace machine consists of two parts, the portion where the lace is made and the Jacquard which governs the pattern; these two parts together form the lace machine in its entirety.

Although lace is a delicate fabric, the lace machine is massive weighing about 17 tons. It is 9 to 10 feet in height, and occupies a floor space of about 50 feet by 10 feet, and may contain from 12,000 to 50,000 threads. The body of the machine, where the lace is made, is from 170 inches to 244 inches in width; a few machines have been built as wide as 260 inches. Quarters, units of measurement of 9 inches, is the term used for expressing the width of a machine.

The machines are driven by gears from individual electric motors of about 3 horsepower each. The working of a lace machine creates a great amount of vibration. Opinion is divided as to whether the machine works best on solid foundations or on floors which communicate a certain portion of this vibration to the shell of the building; in both cases, however, it is customary to fasten the tie bar of each machine to the ceiling of the room, with thick iron bars.

The “point” or the gauge of the machine is an indication of the bobbins per inch. The bobbins per inch is twice the “point” or gauge. In a 10 point

machine there would be 20 bobbins per inch. The machines in this country range from 5 to 15 points, the bulk of them (42%) being $9\frac{1}{2}$ point. Machines are built to given gauges and the gauge is never changed in a machine. The following parts of a machine are all made to fit specific gauges; point leads, bobbins, carriages, comb leads, steel bars. These are the working parts of the inside of the machine and they cannot be interchanged from one machine to another unless both machines are the same gauge or point.

The sley runs the full length of the machine and is about 12" wide. It is similar in texture to the wire screening used on windows but is heavier in material and coarser in mesh. The sley is rubbed over from end to end with a mixture of soap and lampblack until the holes of the screen are filled. It is then painted over with a solution of black varnish to give it hardness and durability, and pricked or "set out" for the entering of the threads in accordance with a specification given by the draftsman. A lace machine is always set out to make a definite width of lace. The sley is placed somewhat to the left of the center of the width of the machine, and the part pricked for a definite breadth is from 2 to 4 inches to the left of the position where that breadth is made by the threads in the machine. This displacement is for the purpose of forming an angle and causes the threads to rub against the left side of the holes in the steel bars, thus preventing them from floating in the holes, as would be the case if they worked perpendicularly from the sley.

The steel bars are long, ribbon-like pieces of watch spring steel, the thickness of a piece of paper. The number of bars varying from 100 to 240, each separated from the next by a thin metal guide called a "brass" which renders their free action more certain, and work side by side without restrictive friction in a narrow space from $1\frac{1}{2}$ to 2 inches wide. These steel bars are perforated with small holes at intervals of 2 or 4 gaits, for the purpose of holding the threads, and are called half or quarter bars respectively. They extend through the length of the machine, and beyond at each end. At the left side of the machine they are attached to individual spiral springs, held in a metal frame, and at the right side they extend a distance equal to two-thirds of the length of the machine itself and are joined to the Jacquard. Between the machine and the jacquard, they spread out in the shape of a fan and pass through an upright brass bar, which holds them in position, before they are hooked to the draw-bits of the jacquard. Each bar is threaded with warp or beam threads, passing vertically through the bars into the space between two comb bars, and fastened to the work roller above. The function of these bars is to deflect the warp or beam threads, through the action of the jacquard, so that a bobbin will pass on one side of a given thread and on its return movement on the other side, thus forming a twist. All the threads in any one individual bar act in the same manner throughout the whole width of the machine.

When the steel bars are stopped they must place each thread between 2

carriages with great accuracy because, when the lateral movements are made, if the thread at the end of its movement is not exactly between 2 carriages, it may be cut down, and the inside parts of the machine may be seriously damaged. In each groove of a comb lead a carriage holding a brass bobbin works backward and forward. The warp and other threads in each gait have a separate bobbin or filling thread; this constitutes one of the fundamental differences in principle dividing the ordinary weaving loom, which has one filling thread to all the warp threads, from the Leavers lace machine.

The tension given to the warp threads is obtained by a cord passed around a metal collar on the end of the beam. One end of this cord is fastened to a stud fixed in the beam frame, and the other end is attached to a powerful spiral spring having a hook attached at the other end; the hook is passed through a perforated metal plate. The screw is drawn up by a wing nut until the cord around the pulley at the end of the beam is tight enough to form a brake sufficient to produce the required tension on the warp threads carried on the beam. For the small gimp and thick thread beams, light cord and lighter springs are used and are adjusted separately.

In a fifteen point machine, 30 carriages and bobbins swing side by side in an inch, with a space between them in which warp and beam threads are congregated, clear of each other and clear of the threads through which they pass.

The carriages are suspended, by the threads wound on the bobbins, from the work roller above, and catch bars fall into the nibs of all the carriages on each side. There are two catch bars above the carriages, one at the front and the other at the back of the warp threads. These catch bars have a to-and-fro and an up-and-down motion imparted to them. The to-and-fro motion alternately pushes and pulls the carriages through the warp or beam threads after they are moved by the jacquard. The front catch bar takes the carriages and draws them up to the combs to the extreme limit of their motion, and returning, pushes them to the center of the well dividing the comb bars. At the back of the warp threads, another catch bar is waiting and falls into the back nibs, and at the same time, the first catch bar rises and releases the carriages, thus allowing the back catch bar to draw the carriages up to their extremity. The comb bars being placed exactly opposite to each other and the carriages being wide enough to bridge the space between. They are entering the comb bar on the back motion before they leave that on the front, and one or the other of the catch bars always holds them, as one does not release the carriages until the other has them engaged. Thus one catch bar conducts the carriage through the warp threads at each motion from one side and then returns them to the other catch bar which seizes them all simultaneously and conducts them back again to the other side of the warp threads.

Perfection of movement and action similar to that of a pendulum, requires the carriages to travel at their greatest speed as they pass the vertical line, and

have a short period of repose at the extremities of their motion; this slight retardation where the machine is opened to its fullest extent is obtained through elliptical gearing so arranged that the slowest part of the motion coincides with the two dead points. The pause at these points gives time to enable the jacquard to actuate safely, and without shock to move the steel bars holding the threads in their proper position. At the same time that the warp or beam threads reach the extreme limit of their movement, the bobbins and carriages pass through with a movement at right angles to that of the warp and beam threads, tying them firmly into position.

Above the carriages are two point bars, one at the front and one at the back of the machine. These long steel bars carry the point-leads, which consist of pieces of cast metal, two inches in width, placed side by side, in which are placed needle-like points about $1\frac{1}{4}$ inches in length, the same number to an inch as the bobbin threads. After each motion a point bar is lowered, the points pass through the threads as soon as they are crossed, compress the twists, lift and fix them firmly to the work which is already finished. The point bars withdraw clear as soon as they have completed the operation, and resume positions to commence the same operation again. These movements are effected automatically and methodically.

Above the point bars are two rollers the length of the machine; as the lace is made, it is wrapped around the upper roller which rests upon a lower one, which is covered with short metal points. This lower roll (porcupine roll) holds the lace taut as it is produced after it has passed over a flat metal surface called the facing bar. As the porcupine is turned by a toothed wheel at a regular and even pace, which does not alter until the wheel is changed, the speed at which the upper roller is turned in the opposite direction by frictional contact with the porcupine is invariable, regardless of the number of layers of lace which are wound around it.

Variations in quality are obtained by means of a series of toothed wheels, which turn the roller at a speed proportionate to the number of teeth in the circumference. Every alternate motion of the machine is recorded by a tooth and pinion wheel, which indicates the number of racks of lace on the roller at any given time.

The standard unit of measure of lace on the machine is called a "rack" and consists of 1,920 single motions of the machine; the number of inches of lace per rack is called the "quality." The smaller the number of the quality, the better in grade is the lace, because there are more machine motions in a shorter length; therefore, a lace of 12 quality, or "12 inch racks" is better in grade than a lace of the same style 18 quality or "18 inch racks." The common range of qualities is 12" to 36", although a range of 6" to 60" is possible.

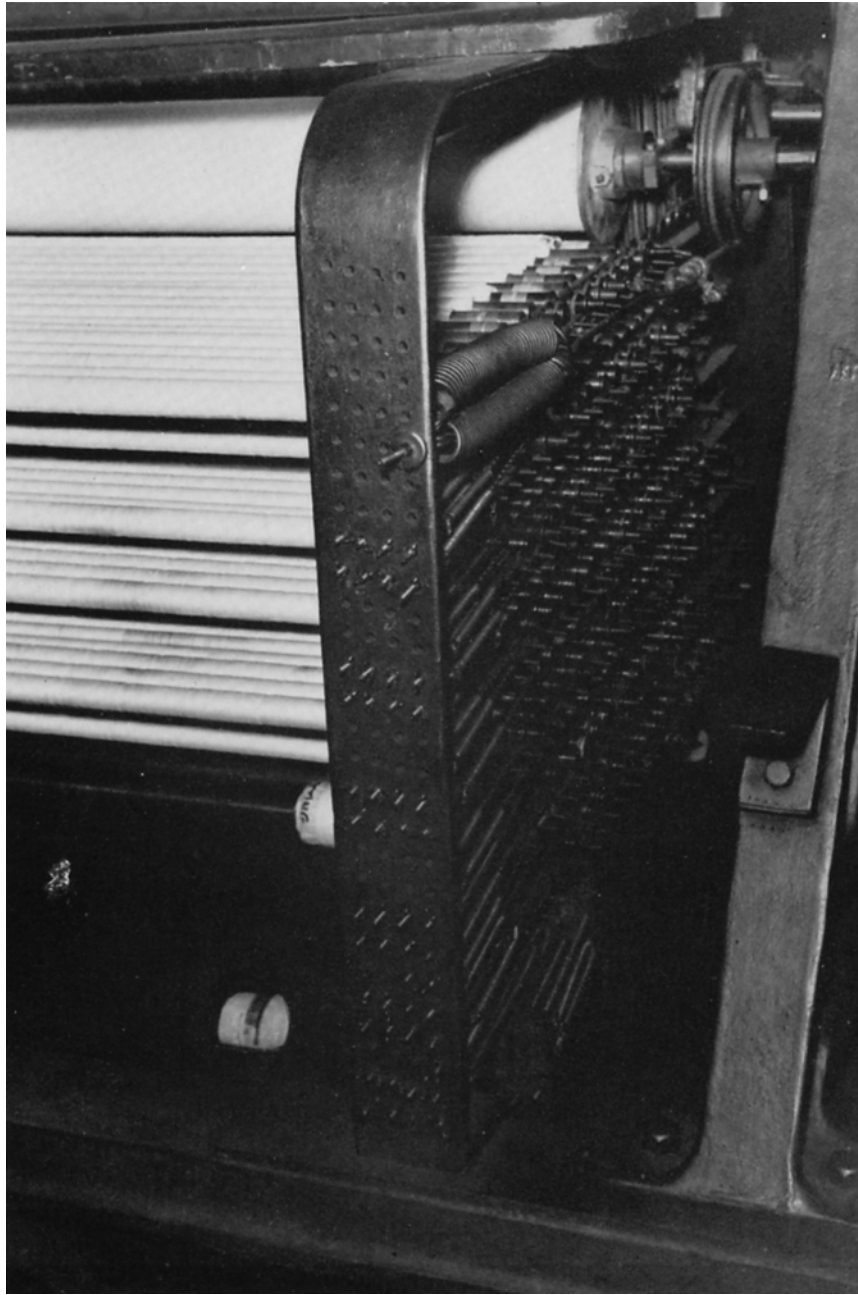

End of Lace Machine showing weighting tackle on warp and beams

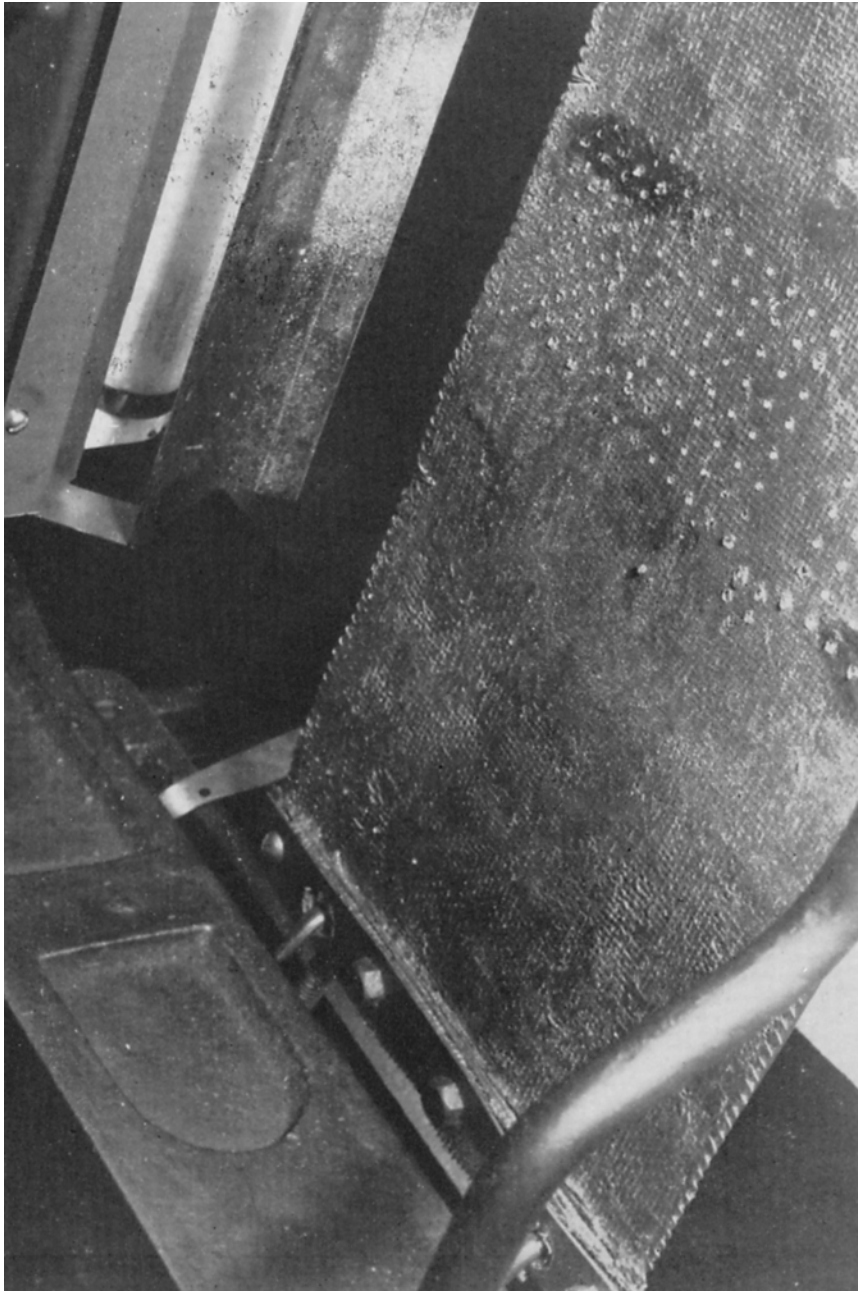

Sley, soaped, varnished and in process of being pricked for the set-out

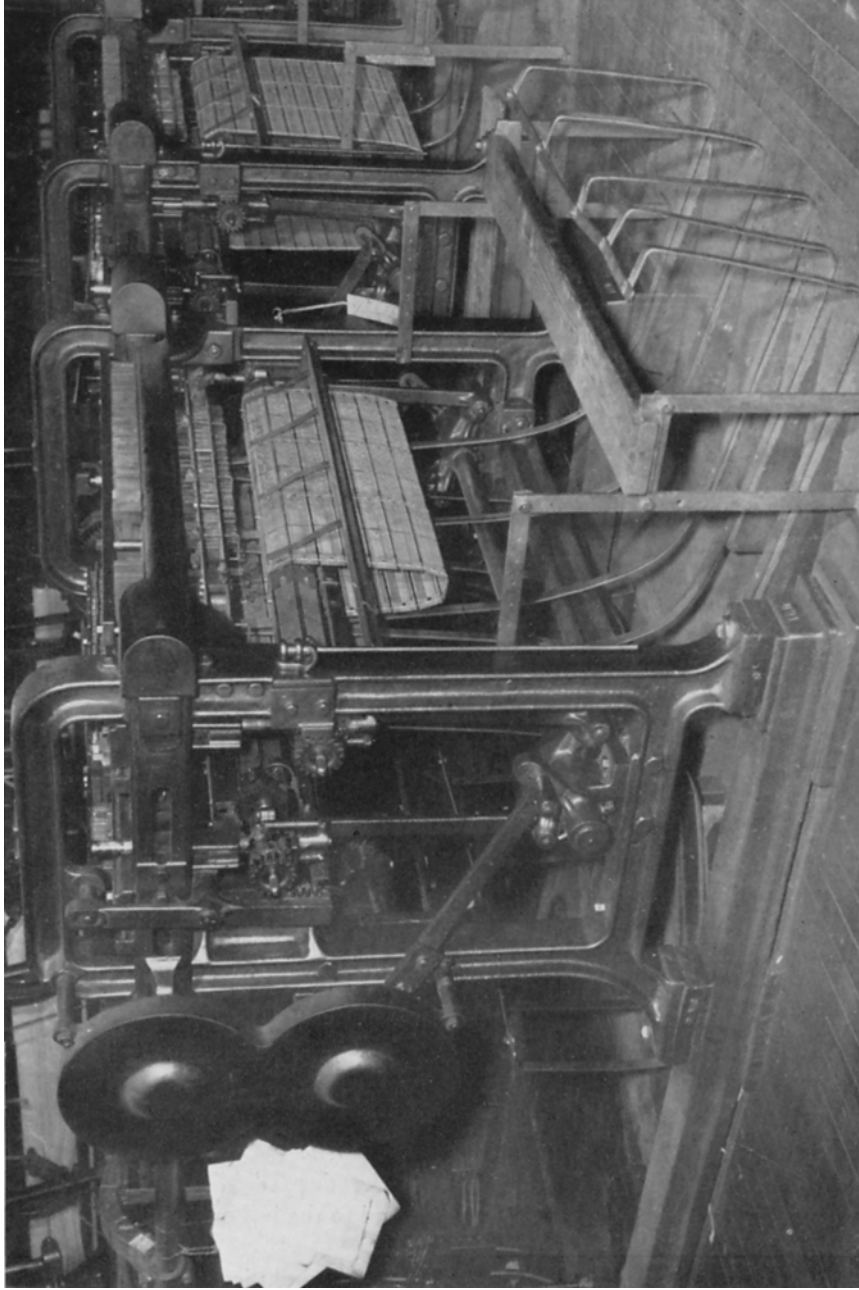

Complete Jacquard assembly in place

Principle of the Jacquard Mechanism on the Leavers Lace Machine

OBJECT —

To move steel bar (A), through which the warp threads are threaded, to the right or to the left.

FIG. I —

- A — Steel bar
- B — Lever
- C — Blade with a lateral reciprocating motion (Driving Blade)
- D — 6 sided, perforated cylinder carrying cards which may be punched so that the holes correspond to the perforations in the cylinder
- E — Warp sley
- F — Slots to hold lever "B" } Fixed and remain in one position.
- G — Dropper sley
- H — Dropper
- J — Spring

Cylinder "D" moves up with punched card 5 on top which allows dropper H to remain down because the end of the dropper enters the hole in the card and the perforation in the cylinder.

FIG. II —

Blade "C" moves to the right, just touching end piece of "B", then moves back to its original position. Lever "B" does not move, therefore steel bar "A" remains in same position.

FIG. III —

Cylinder "D" moves down, turns $\frac{1}{6}$ th of a revolution, and moves up with blank card 6 on top. The card forces dropper "H" up between blade "C" and end piece of lever "B".

FIG. IV —

Blade "C" moves to the right, pushes dropper "H" which in turn pushes lever "B" thus causing steel bar "A" to move to the right and deflect the warp threads threaded through it.

Blade "C" moves back to the left while cylinder "D" is lowered, thus causing dropper "H" to fall. Spring "J" attached to the left end of steel bar "A" pulls lever "B" back to its original position.

Cylinder "D" is now ready to turn $\frac{1}{6}$ th of a revolution and move up with card 7 to repeat the whole procedure.

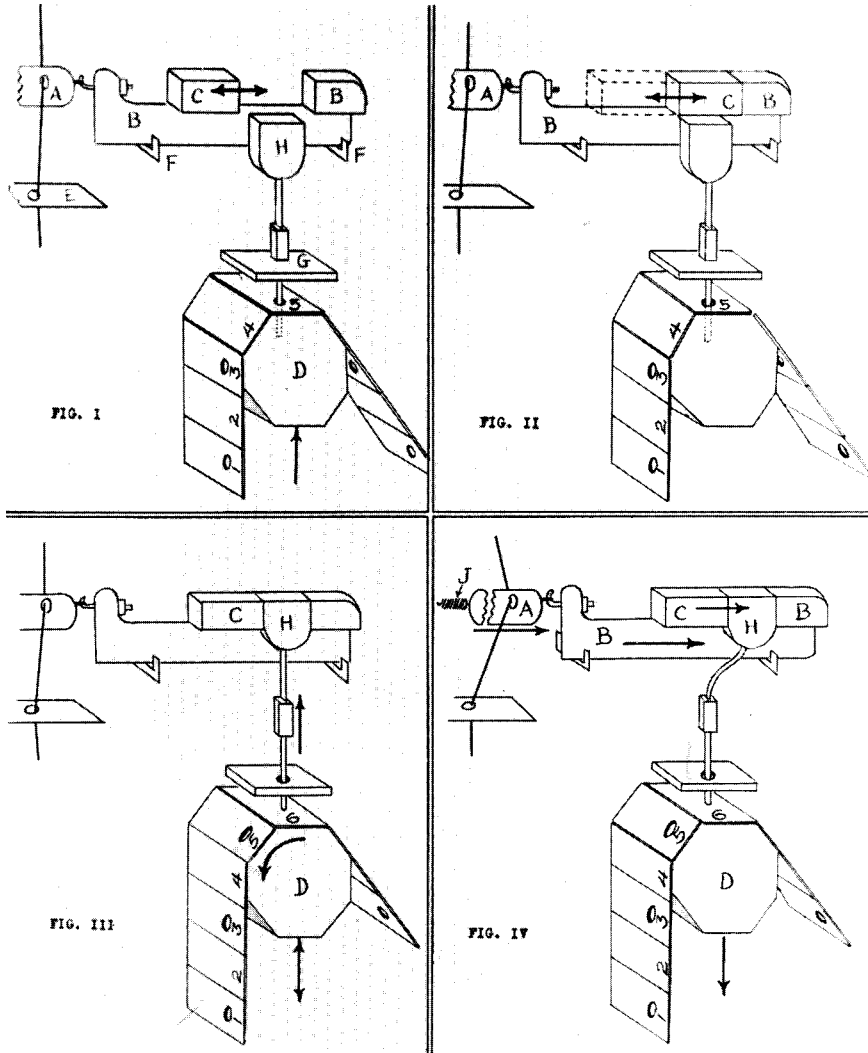

Principle of the Jacquard on the Leavers Machine

THE JACQUARD: The jacquard mechanism is connected to the lace machine by a steel shaft, fitted with two or three wheels in front of the machine by which the twisthand can obtain leverage to start and stop the machine. This center shaft runs the entire length of the machine and the steel bars at the right hand of the machine, until, at its point of contact with the jacquard, a cogwheel on the shaft engages with another cogwheel attached to the jacquard. These cogs are so adjusted that the motion of the machine synchronizes with the motion of the jacquard. Therefore, when the front motion of the jacquard has placed the threads in position, through its action on the bars, the carriages pass through on the front motion and the front point bar takes up the twists which have been made and vice versa.

The jacquard has two cylinders with seven droppers to a bar and is a much more complicated system than that applied to ordinary looms. In the ordinary loom the warp threads are moved up or down and always the same distance. The jacquard of the Leavers machine moves the warp threads to the right or to the left any number of gaits from one to thirty-nine. A gait is the distance between two adjoining carriages.

Two metal plates cross the top of the jacquard and are grooved with as many independent slots as there are available spaces for bars in the jacquard. In each of the grooves is placed a thin metal plate called a "bar box." These bar boxes are attached to and control the steel bars. When the driving blade moves forward it clamps the dropper between the bar box and the driving blade. Since the bar box is attached to the steel bars which contain threads, they will be moved forward for a distance equal to the thickness of the dropper. When the driving blade is moved backward it releases the dropper.

Underneath the boxes are two hexagonal cylinders, each cylinder being the width of the jacquard, one placed at the front and the other at the back. These are rotated alternately one sixth of a complete revolution, and so alternately control the two sets of droppers of the front and back motions. These cylinders are pierced from end to end, on each face, with seven rows of holes equally spaced. Above each cylinder are two brass plates. The upper one is perforated with square holes and the lower one with round holes which correspond exactly with those in the cylinder. Above these plates are the boxes containing droppers, which are held separately and in a definite order in the brass plates which support them vertically, each with its head below the level of the driving blade.

A dropper is a steel pin about ten inches long with an enlarged head; droppers are of six sizes, each head being equal in size to a specified number of gaits. The first, called the "dummy", is longer than the others and is always working, as it is upon its upper part that the other droppers are bedded when raised; the lower part carries an enlargement equal to half the distance between two carriages and is called the "half gait"; it is used in long throws to insure the thread being carried to its required level. The next dropper is

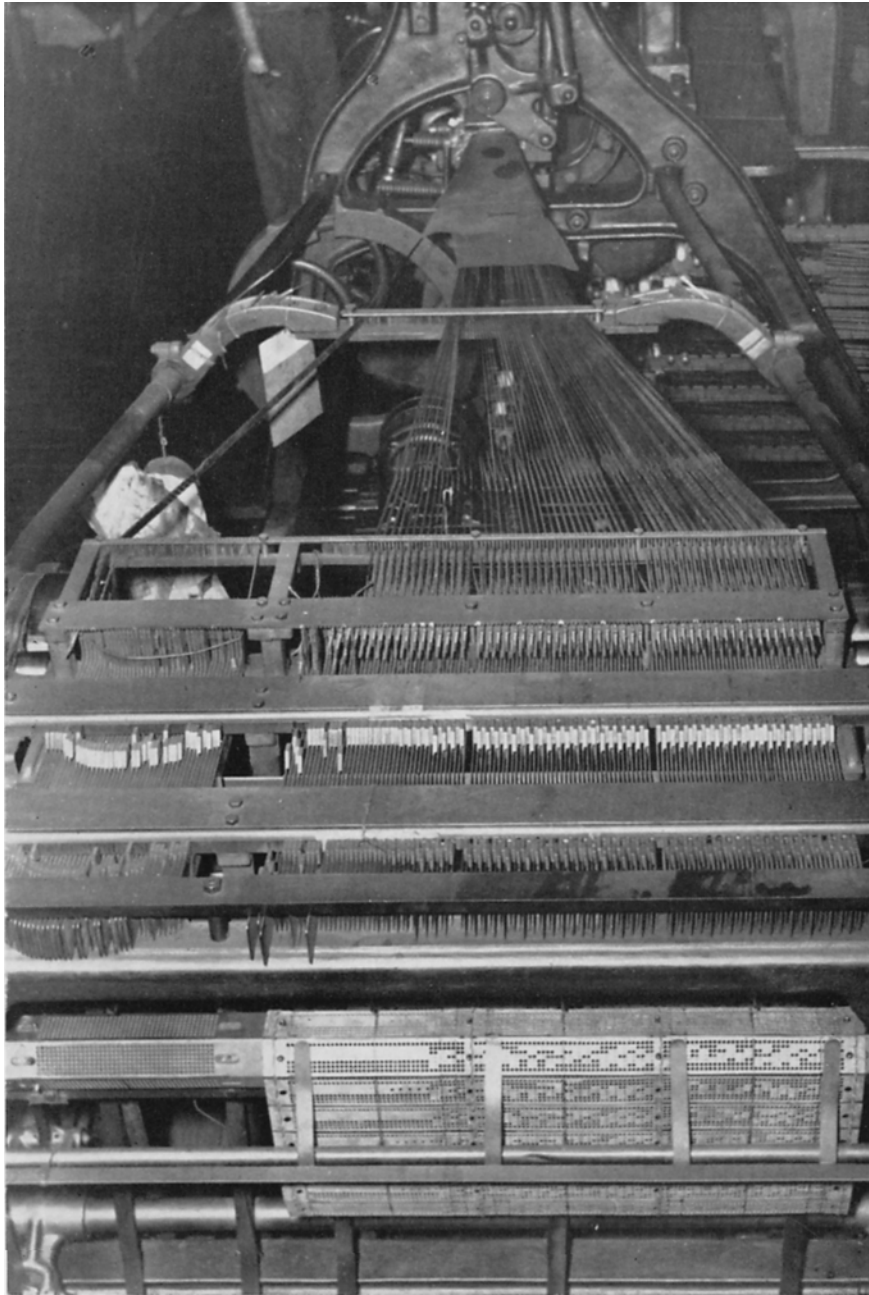

End view of Lace Machine showing Jacquard and Bars entering the machine

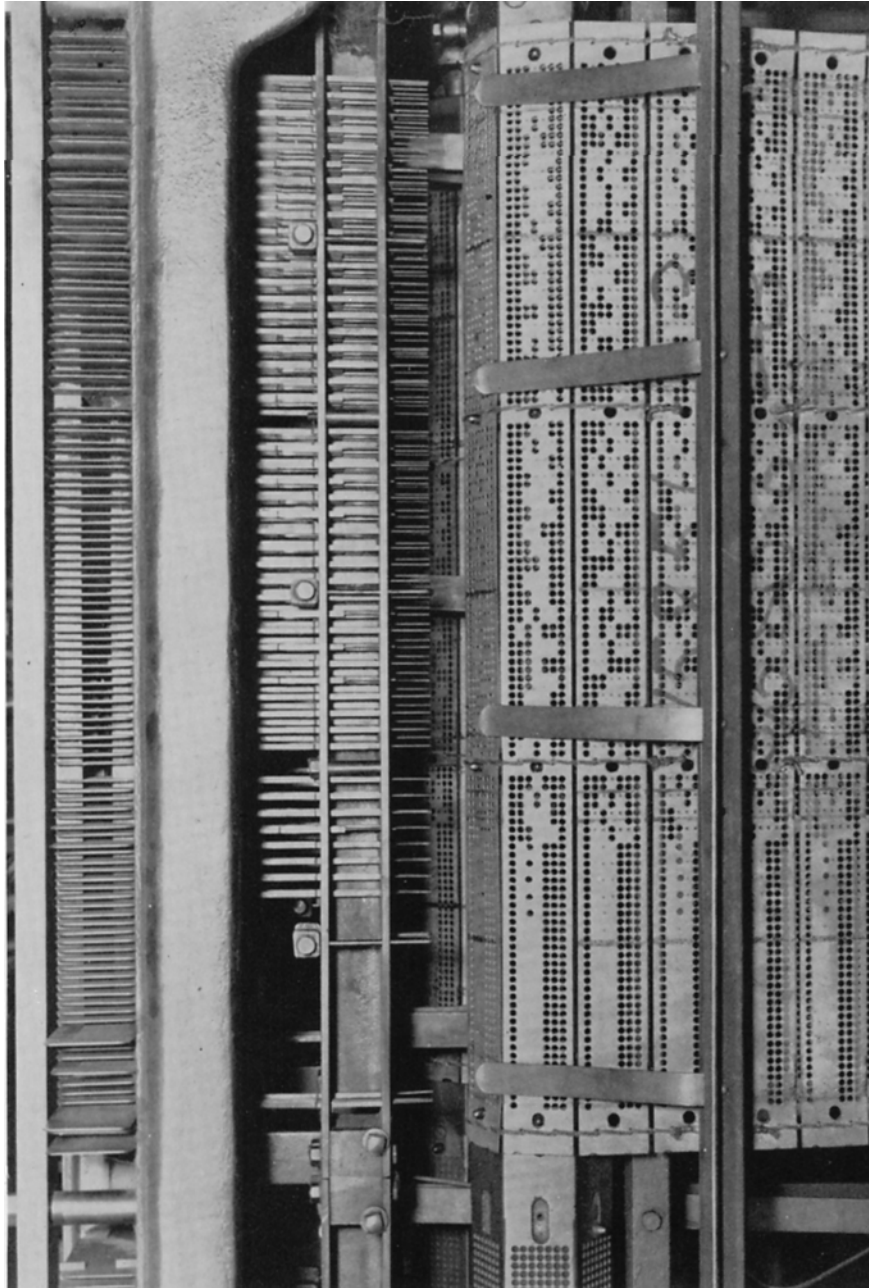

Close-up of the front of the Jacquard. Top, bar boxes; center, droppers; bottom, Jacquard cards resting on the cylinder

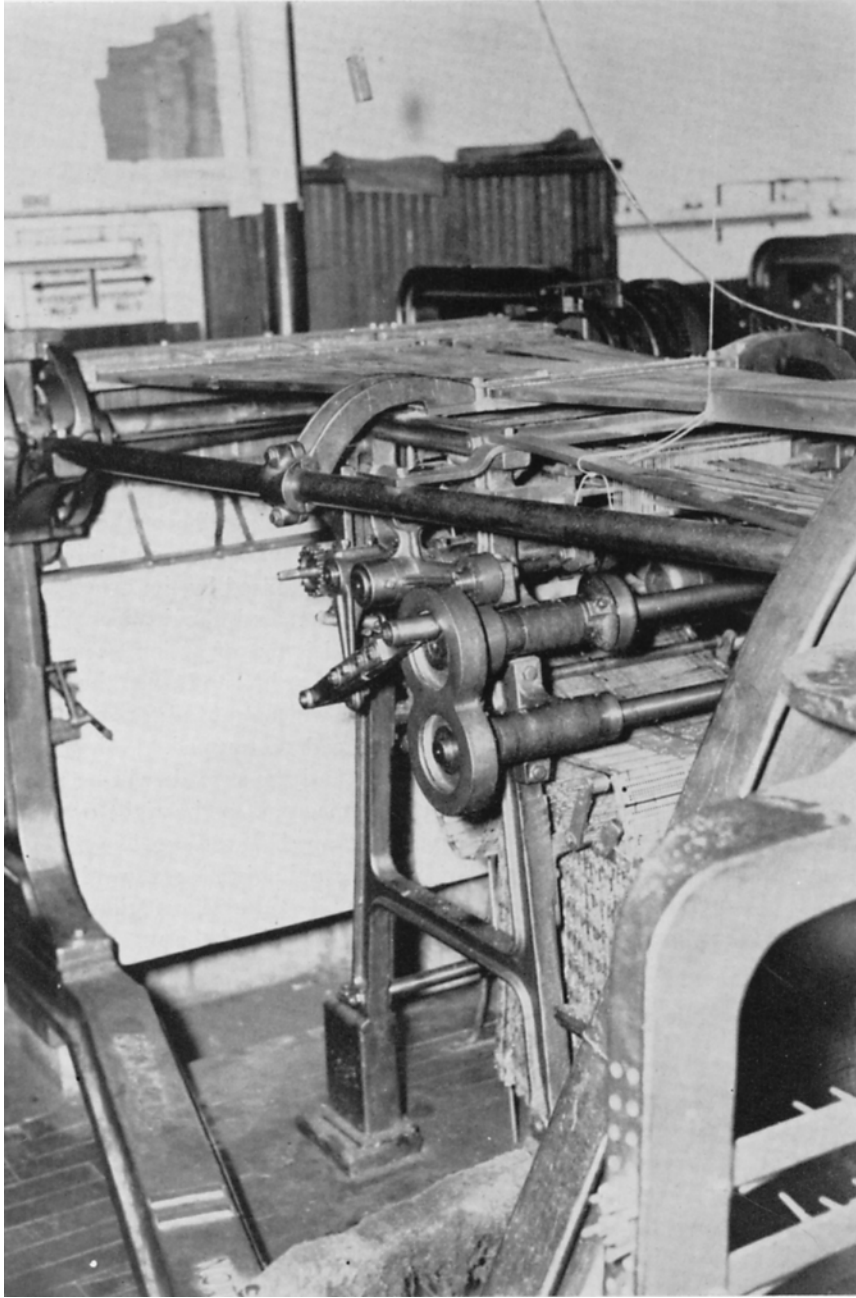

Bottom bar Jacquard in place

equal in thickness to one gait, and the next to two, the next to four, the next to eight, each, and the last, sometimes to eight, sometimes to sixteen gaits. Beginning with the two gait, each of these droppers is grooved at its lower edge in order to bury any of the droppers in front of it which may not be raised. The exception to this is the second eight gait dropper which is different in shape because it never has to bury another dropper and never works except in conjunction with the first eight immediately in front of it. The sixteen gait, when used, must bury the second eight only and such other droppers as are not raised in front of the first eight gait. The play of these droppers must be exceedingly free. They are lubricated with powdered graphite, as are the comb leads, carriages and steel bars.

The cards of the pattern are passed over the cylinder and work in an endless chain. Each cylinder has an up-and-down motion imparted to it, each card lies temporarily upon the upper flat side, and when the cylinder rises, its surface is replaced at each motion by the surface of a card presenting either holes or plain space, which is pressed against the lower brass plate, and the vertically placed droppers are raised by the portion of the card not punched out, which can be arranged so that they may present any combination of numbers to place the threads in the lace as required by the arrangement of the draft. If the space under the dropper is punched, the dropper pin falls through the hole into the hollow cylinder and is out of action. The heads of droppers which are raised, are raised into the bar box and when the driving blade moves forward, the front movable part will be moved forward to the extent of the sum of the size of the dropper heads so trapped.

Consequently, the bar will be deflected and the threads will be moved laterally throughout the length of the lace machine to the right or to the left, according to the number of droppers entrapped. If the one, two, and four gait droppers are raised, the bar will rise (move to the right), seven gaits above the dead-stop (the lowest position of the bar); if at the next motion the four gait dropper alone is required, the spring at the left of the machine draws the bar back again, so that the thread will stand four gaits above dead-stop, and when the droppers in one motion fall after carrying out their work, the bar has already been controlled by the droppers of the other motions. Therefore, the threads do not sink to dead-stop and are not required to return from that place to their new position. A bar rarely throws more than ten gaits at once. It is while the carriages are at the extreme limit of their motion that the jacquard moves the steel bars to the prearranged positions for each motion of the pattern. When the threads have reached the extremity of their movements, the carriages pass through to the opposite limit of their motion, the threads are tied in, and the point bars take up the lace which has been completed.

After each motion a point bar is lowered, the points pass through the threads as soon as they are crossed, compress the twists, and lift and fix them

firmly to the work which is already finished; the point bars withdraw clear as soon as they have completed the operation and resume positions to repeat the same operations. These movements are effected automatically and methodically. Thus, all the parts of the machine operate in perfect accord with, and in some instances, in obedience to the jacquard, which controls all the movements of the threads in the course of making the pattern. The threads in each bar move independently, but coordinating with the movements of other bars.

The cylinders repeat the operation alternately, of presenting a card to the surface of the dropper plate, so that the spaces between the driving blades and the front of the boxes are served alternately also, and the whole series of cards is brought successively in contact with the lower brass plate, time after time. Thus, the jacquard expresses the pattern by actuating the thread-controlling devices of the machine and it is by modification of the lateral movement of the threads that the varieties of patterns are produced. The threads in the bars are worked in a predetermined fashion and produce an enlacement of warp and bobbin threads by the impulse communicated to the warp threads by the jacquard. In a way, the draft is active and compels the threads to pass into such positions as are necessary to reproduce the original design with all the artistic touches which have been added to it.

SUPPLEMENTARY JACQUARDS: The capacity of the jacquard is sometimes extended by the use of a supplementary jacquard, operating what are known as "bottom bars". In the manipulation of bottom bars, all the warp threads are passed through 2 sets of bars, known as "bottom bars" and "stump bars". These are placed in two ranks, one above the other. The bottom bars are below the stump bars, and the stump bars are placed in the well of the machine, along with the other top bars. There are, as a rule, four stump bars, and they are of heavier caliber than the other steel bars. The function of the bottom bar is to place the thread at the top or bottom side of the hole in the stump bar as required and the action of the stump bar twists the thread with the bobbin thread at either the top or bottom side of the gait, according to the position of the thread in the hole on the stump bar, as provided by the action of the bottom bar. The bottom bars may throw as much as two inches, but the stump bars generally move only across one carriage, though it is possible to throw them over two or more carriages.

This work necessitates the use of two jacquards, the ordinary top-bar jacquard and the bottom-bar jacquard, which is much smaller and is placed underneath the bars of the top-bar jacquard. The bottom-bar jacquard has but one cylinder, and its rate of speed is, therefore, double that of the individual cylinders of the top-bar jacquard. Horizontal needles connect with other vertical needles and so actuate the bottom bars. The threads in the stump bars cannot function at the places where the stump bars are supported over the



Removing a set of carriages

brackets, and a few bars are used from the top-bar jacquard, as many as are necessary, equally divided between the back and front bars, and behind and in front of the stump bars. As a rule, the number of bottom bars does not exceed 600, but as many as 1,200 have been used; this large number necessitating an arrangement in tiers.

11. Brown Inspection and Mending

A web of lace is the full width of the machine and usually consists of many bands joined by lacer threads. A web may be any length but for convenience in handling and packaging in subsequent operations, it is usually about 36 yards long.

Lace suffers some damage in the process of making; threads break, bars misgait or are too high or too low in the gait. When the inspectors find a defect they tie a loose knot over the damaged place. These parts are mended on sewing machines. The mending is done very rapidly and the mended part is very difficult to detect.

Low quality narrow breadth laces are not mended.

12. Washing and Scouring

After mending, the lace is soaked overnight in a solution of soap and graphite remover in order to loosen all the dirt. The next day the material is scoured for twenty minutes in hot soapy water in a "dolly." This is a huge wooden tub in which six large wooden hammers or mallets pound the lace and knock out the dirt while the tub is rotating.

Another method of washing and scouring is to run the lace (7 or 8 webs) for 1½ hours in a scouring machine. This machine consists of a large tank above which are two large squeeze rolls, the bottom roll being wrapped with manila rope. The ends of each web are sewn together to form an endless chain which rotates through the squeeze rolls and into the tank which contains a hot solution of soap and soda ash.

13. Silk Degumming

Silk laces are made with raw silk yarns which means that the gum (sericin) has not been removed. The process of silk degumming is about the same as the squeeze roll method of washing and scouring. The silk material is run through a hot soapy solution for about 1½ hours. The silk loses about 25% of its weight due to the loss of the gum.

14. Bleaching

Since laces are made with yarns in the natural state they are bleached after washing and scouring. Bleaching is done in a solution of hyperchloride of lime followed by an acid bath. The lace is then washed and blueing is

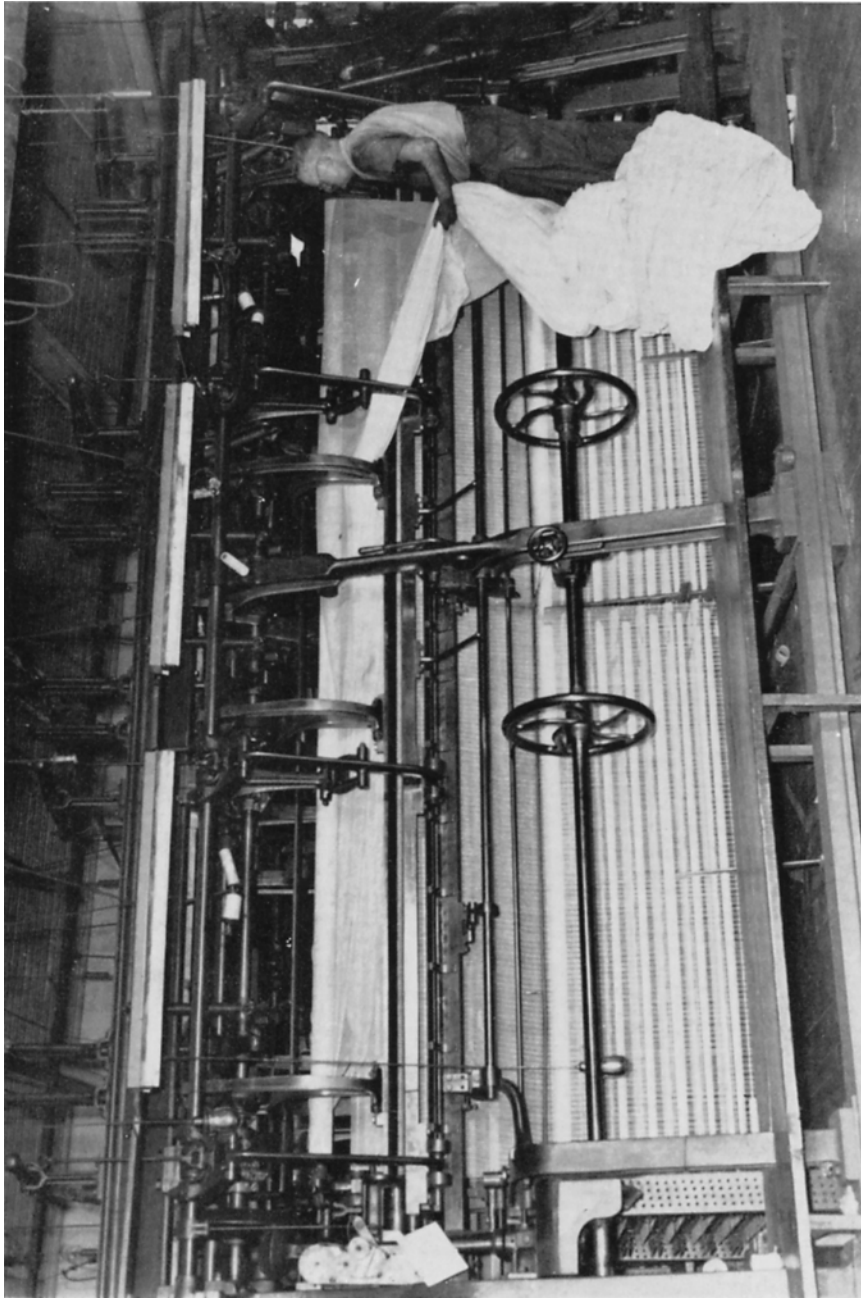

Removing a web from the machine



Brown inspecting



Brown mending

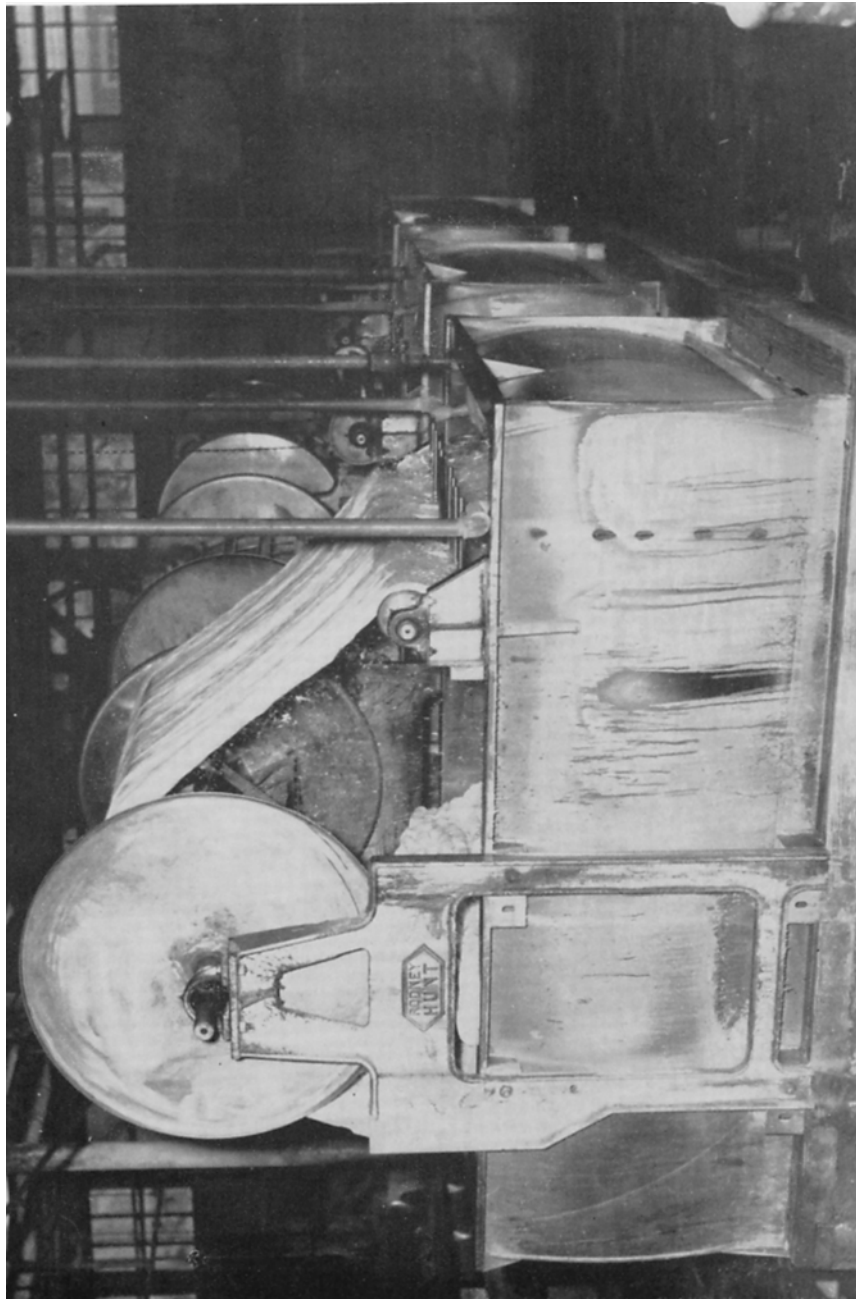

Washing and scouring

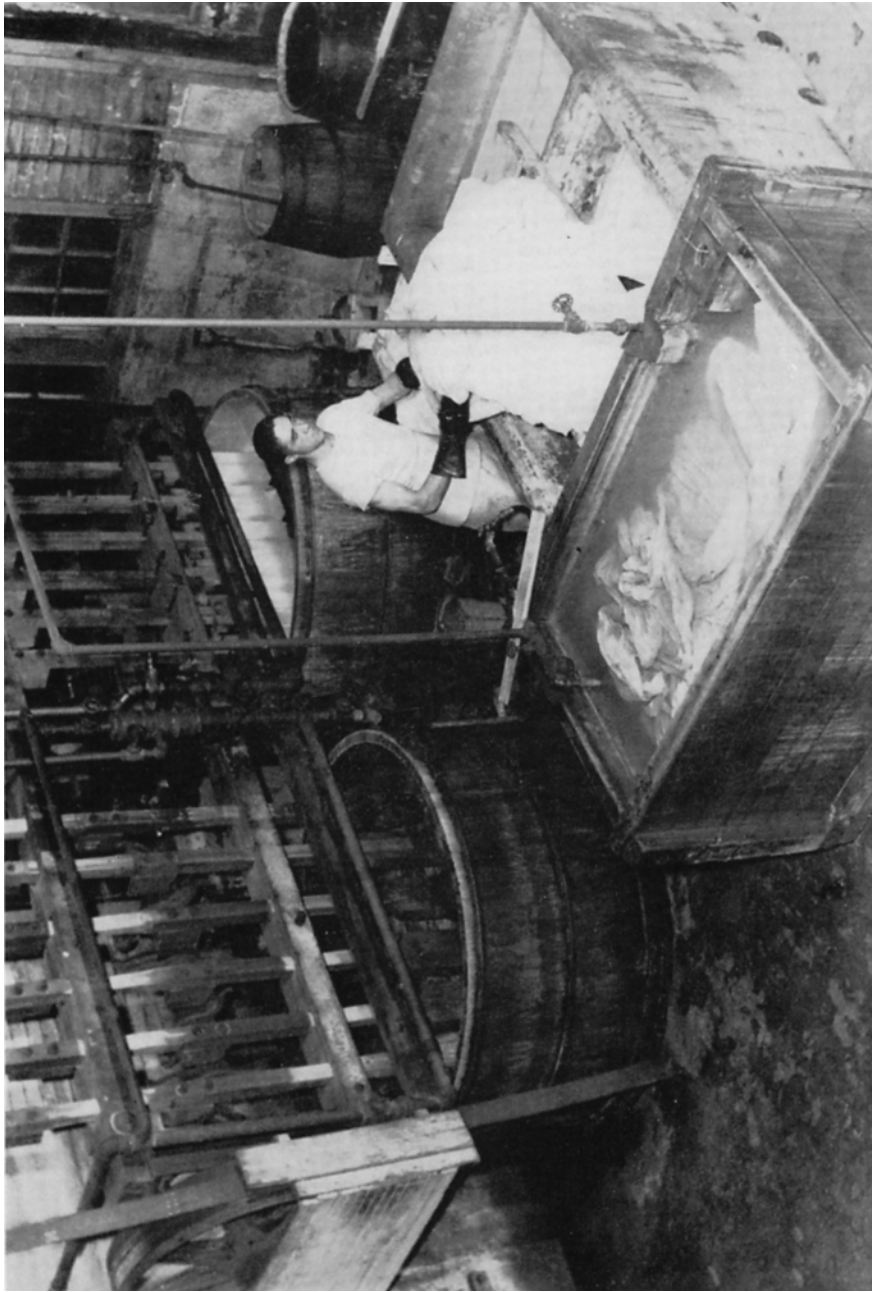

Bleaching tanks with dollies in the background

added if the lace is not to be dyed. The blueing neutralizes the yellow tinge which remains in the fabric even after the most careful bleaching.

15. Extracting

If the lace is not to be dyed, the next operation is extracting. This means that excess water is removed by the action of a whirling perforated tub and the fabric is left in a damp dry condition.

16. Dyeing

Only about 5% of the lace production is dyed, the remainder being sold in the white. The most common color is black, other colors are pink, pale blue, yellow and ecru. Practically all colors are used but the percentage of the total is negligible. After dyeing, the fabric is rinsed in clear water to remove all excess dyestuff.

17. Extracting

After rinsing, the excess water is extracted.

18. Starching

Bleaching or dyeing leaves the lace fabric limp. To overcome this condition, the material is run through a starch mangle where a thin starch paste is applied. Squeeze rolls remove the surplus starch solution. In the case of rice nets, or coarse nets used for hat shapes, the amount of starch is increased and is not run through the squeeze rolls.

19. Tenting or Dressing

The purpose of the dressing or tenting is to obtain the full extension of the meshes to the proper shape, the recovery of the width to the same size as on the machine, and the stiffening of the fabric to prevent collapse when the piece is taken from the frame, so that the design will be symmetrical and not distorted.

A dressing frame consists of two extended, parallel, horizontal bars, equipped with means of supporting and stretching the fabric. A frame is capable of handling one web of lace six yards wide and thirty-six yards long. The distance between the parallel bars is adjustable and the inside of the bars is lined with pins, upon which the selvage is fastened, without any damage to the lace. During drying the bars of the frame are gradually separated to keep the lace under constant tension. The whole process is similar to a giant curtain stretcher.

All pieces shrink when taken from the lace machine. Some laces are dressed to the same width as they are made, but pieces of filet or square-mesh lace cannot be dressed to their full width. Ensor net (six-sided mesh), on the other hand, can be dressed wider. The only type which is habitually dressed

wider is veiling, which is sometimes stretched to more than four times the width of the piece on the machine, losing in length in the process.

The dressing rooms are kept at a very high temperature but they are well ventilated, with numerous windows, and the air is being constantly changed and kept in motion. Large canvas fans revolving above the dressing frame circulate the hot air downward and dry the lace in about thirty minutes.

After the lace is dried, a wooden frame about seven yards long and 18 inches wide, called a "folder", is laid across one end of the web. Operators walk up each side of the dressing frame and keep turning the folder until the lace web is all wound on it. In some mills tenter frames have been installed, but this is only practical in mills having very large production, since the speed of the tenter frames is so great that they keep far ahead of the production of the lace machines themselves. Each horizontal bar of a tenter frame is equipped with an endless chain of pins. The whole frame is enclosed in a housing where a temperature of 110 degrees Fahrenheit is maintained. The lace is fed full width in one end of the frame and travels through its entire length by means of the endless chain of pins, and comes out the other end all dried and stretched.

20. White Inspection and Mending

After the lace has been dressed or tented, it is inspected for defects which may have occurred during washing and scouring, bleaching, extracting, starching or tenting. This step is similar to brown inspection and mending.

21. Hand Drawing

The processes which take place from this point on are known in the lace trade as "finishing" and should not be confused with the term "finishing" as applied to woven goods.

Hand drawing is the process where the lace web is separated into single lace breadths or bands by removing the lacer threads which join all the bands together to form the lace web. This work is done by women who remove the lacer threads by hand, thus allowing the breadths to fall apart. This hand drawing is gradually passing out of the picture as it is being replaced by the acetone process.

22. Acetone Separating

In lace webs separated by this method, acetate rayon lacer threads are used to join the individual breadths. The lace webs are sent to the acetone plant in bundles where they are opened and wound on rolls. From the rolls the lace is wound on iron cylinders or pipes about three inches in diameter and seven yards long. The reason for rewinding is to make as small and compact a roll as is possible. This roll is then wrapped in a net which protects the lace from scum in the acetone bath. The lace is then placed in tubes about



Centrifugal extractor

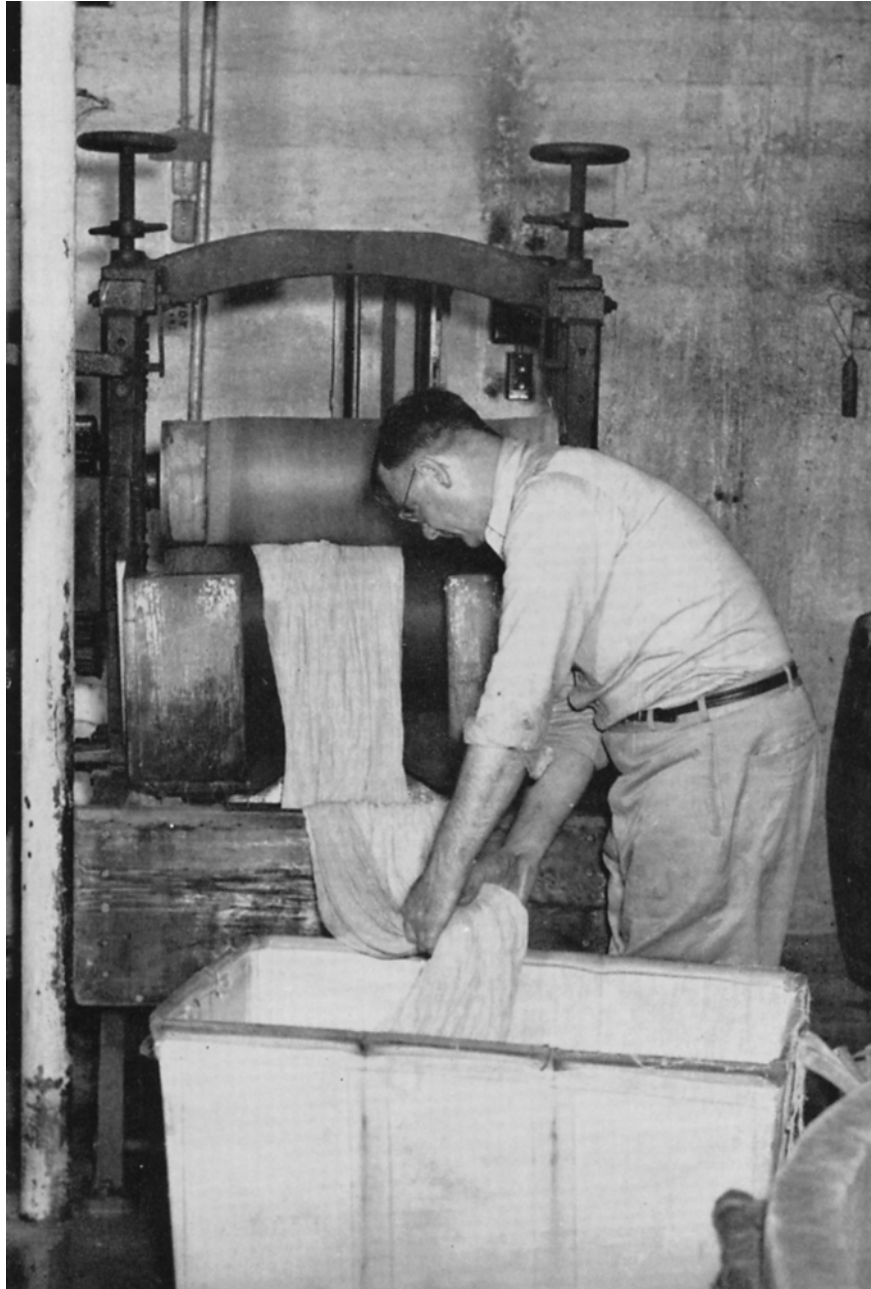

Starch mangle



White inspection

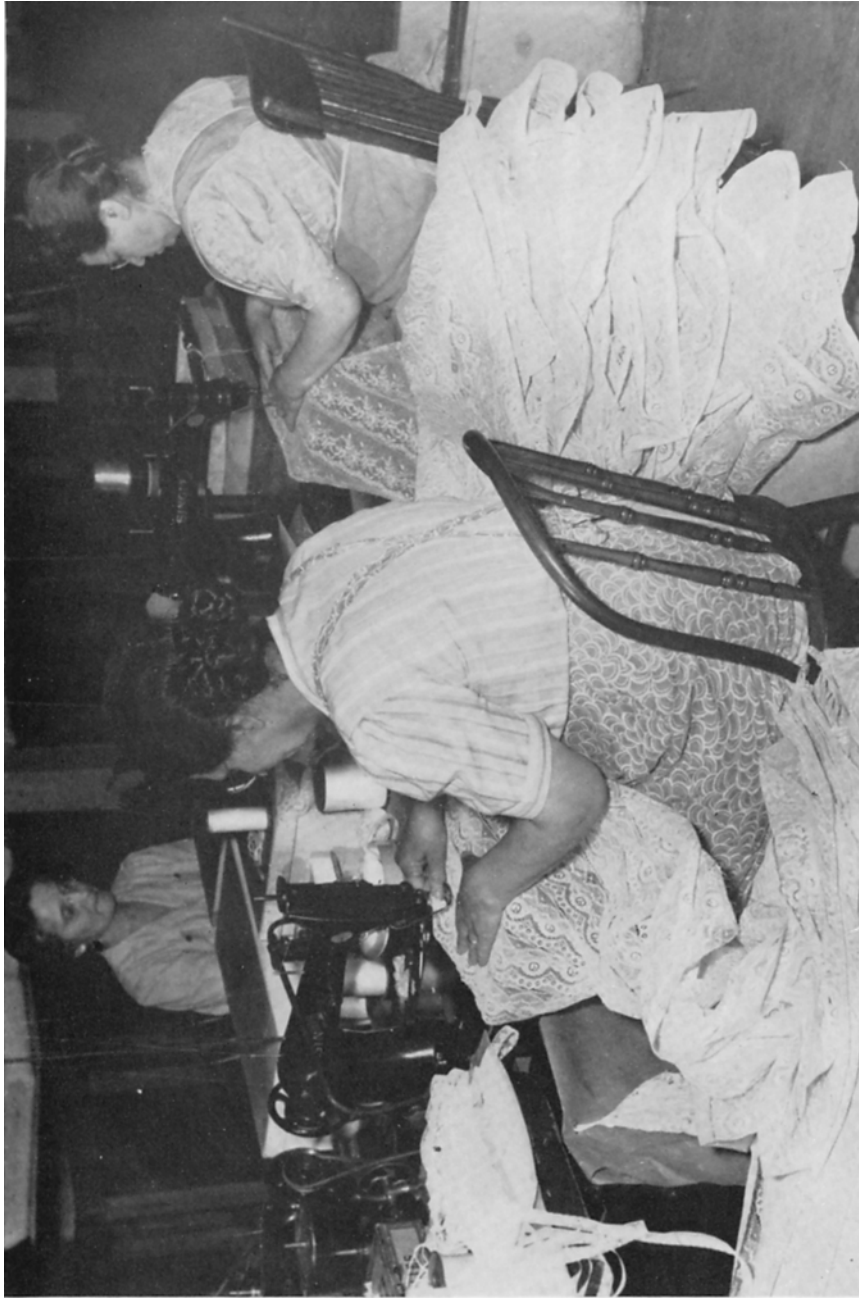

White mending

twenty-two feet long and one foot in diameter. These tubes are arranged in groups of nine so that nine webs may be treated at the same time. One plant may own many groups of nine. After the lace is in the tubes, they are made air-tight by screwing down covers over the openings. First, a vacuum is applied to remove traces of fumes and liquid of the previous bath. Acetone is then pumped into the tubes and is circulated around for about 1½ hours. During this time, three separate baths of acetone are sent through the tubes.

1. The first wash is dirty acetone from many preceding baths.
2. The second wash is known as “cleaner”. It is not pure acetone, but is cleaner than the first wash.
3. The third wash is pure acetone.

After the third wash, the acetone and the vapors are pumped out of the tubes. Next, steam is circulated through the tubes for about two hours. The steam is under five to six pounds pressure. A vacuum is again applied and the lace is removed from the tubes.

The net cover is removed from the roll and the cylinder is placed in a stand where the lace is rewound on six tubes, each about one yard long. The lace is sent back to the shipping room on these small tubes.

23. Clipping

Some lace patterns have heavy loose threads which pass from one detached motif to another and these are removed by clipping. Clips may be removed by machine or by hand.

In a clipping machine, the work is done automatically by the blades of revolving knives, similar to those of a lawn mower, while the lace, clip side up, is run beneath the knives. The cut threads are withdrawn by suction.

In hand clipping, two operators sit before two rollers about one yard apart. The operators unwind the lace from the back roll on to the front roll as each section of the web is clipped of loose threads with scissors. Although this process is slower than machine clipping, the work is neater and there is no possibility of damaging the lace.

Scalloping

Few laces have a straight front. Most of them are indented or curved, the surplus material being cut out by hand. To-day most of the mills omit this operation as the garment trade does its own scalloping and cut-outs. One reason for this is that many lace patterns may be cut in various ways so as to produce a number of different motifs.

24. Jennying

The first operation in packaging is to wind the lace by “jennys” on cardboards, the usual amount placed on one card is about thirty-six or seventy-two yards.

The breadths of hand-drawn laces are placed in large baskets. The operator takes out one breadth at a time and winds it on cardboards.

The cardboard tubes of acetone separated lace are placed on a rod at the end of a thirty-six yard table. The ends of the breadths are drawn down the length of the table which has an adjustable end to make the table fit the length of the lace, and at the same time gives the exact length of the breadths. Jennying is carried out at each end of the table.

25. Packaging and Ticketing

The lace is bound on the cards by a strip of blue paper inserted beneath the outer layer to show the pattern. Next the cards of lace are placed in a bale press and compressed for about ten minutes. This flattens the packages in order to use less shipping space. The packages are then ticketed and wrapped for shipping.