

WARP AND WEFT

*Reprinted from WOOL KNOWLEDGE
The Journal of Wool Education*

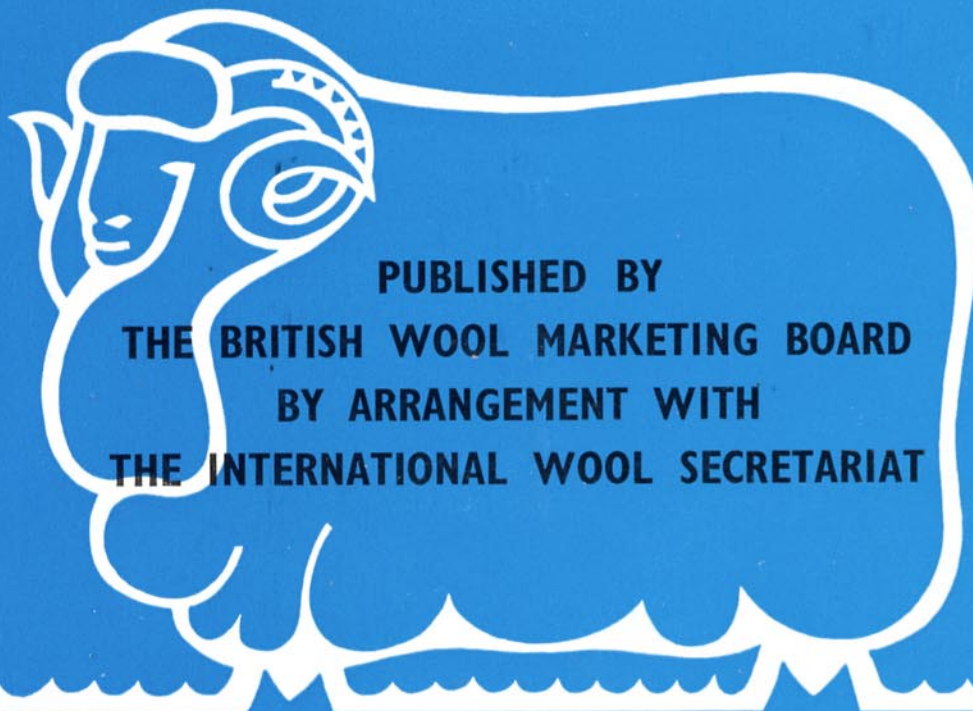

**PUBLISHED BY
THE BRITISH WOOL MARKETING BOARD
BY ARRANGEMENT WITH
THE INTERNATIONAL WOOL SECRETARIAT**

WARP AND WEFT

Reprinted from

WOOL KNOWLEDGE

The Journal of Wool Education

PUBLISHED BY THE BRITISH WOOL MARKETING BOARD,
KEW BRIDGE HOUSE, BRENTFORD, MIDDLESEX,
BY ARRANGEMENT WITH THE INTERNATIONAL WOOL SECRETARIAT.

CONTENTS

WOOL SCOURING	3
<i>W. L. THOMAS</i>	
CARDING WOOL FOR WOOLLEN YARNS	7
<i>P. P. TOWNEND, Ph.D., F.T.I.</i>	
THE SPINNING OF WOOLLEN YARNS	12
<i>J. G. MARTINDALE, B.Sc., Ph.D., A.Inst.P., F.T.I.</i>	
CARDING WOOL FOR WORSTED YARNS	18
<i>P. P. TOWNEND, Ph.D., F.T.I.</i>	
WOOL COMBING	22
<i>H. BEEVERS, F.T.I., C.G.I.A.</i>	
THE MANUFACTURE OF WORSTED YARNS	
<i>H. BEEVERS, F.T.I., C.G.I.A.</i>	
Part I—From Combed Top to Final Roving	28
Part II—From Final Roving to Worsted Yarn	36
POWER-LOOM WEAVING OF WOOLLEN AND WORSTED FABRICS	41
<i>D. C. SNOWDEN, M.Sc., F.T.I.</i>	
THE TEASELS OF SOMERSET	49
<i>DONALD MULLINS</i>	
COLOUR AND WOOL	51
<i>D. R. CHRISTIE</i>	
THE WELSH WOOLLEN TEXTILE INDUSTRY	55
<i>O. W. LIPTON, B.Com., M.Inst.M.S.M.</i>	
THE WOOL COTTAGE INDUSTRY OF INDIA	58



Raw wool. Note the greasy and dirty appearance.



Clean, scoured wool.

WOOL SCOURING

W. L. THOMAS,

Formerly Chief Chemist, Woolcombers Limited, Bradford

THE statistics for wool consumption in the United Kingdom for the past few years show the amount of raw merino and crossbred wools used for top making and woollen spinning to be well over 250,000 tons per annum, and this does not take into account various types of hair and waste materials.

The whole of this very considerable quantity of wool, whatever its ultimate form and destination, has to be cleansed in order to remove the natural grease, dirt and other impurities and leave the wool fibres in a clean, free and natural condition, ready for the subsequent processing. The percentage of these impurities varies very considerably in different classes of wool; for example, an average merino quality will contain from 45 to 55 per cent impurities, whereas a crossbred type may show 25 to 35 per cent "shrinkage", or decrease in weight after scouring. It is of vital importance that this cleansing process be carried out efficiently, and in the worsted industry, the processes of carding, combing, spinning and weaving depend on adequate initial scouring of the wool.

CLEANSING PROCESS

The cleansing of raw wool is now chiefly carried out by scouring with normal detergents in a special machine generally known as a "washing set", in some cases preceded by a water steeping process to remove, as far as possible, the heavy sand and water soluble impurities before the scouring proper.

The washing set consists of a series of tanks or "bowls", usually four in number, separated from each other by pairs of squeeze rollers. Water and steam

pipes are fitted to each bowl for filling and heating, and valves for emptying the bowls rapidly when required. The bowls, when filled with water, are heated by injected steam to the required temperature, usually about 120° to 130°F. and the detergents are added to the bowls generally in liquid form of specified strength.

The wool is automatically fed into the first bowl of the series from a hopper by means of a travelling "lattice". When it falls into the scouring liquor it is gently passed along by a mechanical arrangement of moving forks assisted by posers*, to ensure quick immersion and constant circulation of the scouring liquors. When it reaches the end of the first bowl the wool is conveyed to the squeeze rollers which squeeze out the liquor and pass the partially cleansed wool to the next bowl. In some cases, a special conveyor and automatic discharge valve is fitted to the bottom of the bowl to remove the settled sand and dirt at frequent intervals. This enables the bowl to be self cleansing and thus increases the time for which it can be run between full discharges.

Passing through the other three bowls, in a similar manner, the wool is finally discharged from the fourth bowl in clean condition, and conveyed by means of a travelling apron to a drier, then by truck or blown by a fan to the next process – that of carding.

SUPPLIES OF SOFT WATER

One of the first essentials for the efficient scouring of wool is a plentiful supply of soft water, a condition

*Special pushers.

which is generally met, in the West Riding of Yorkshire, by supplies from the various Corporations or from private boreholes. Where hard waters are encountered the usual Base-Exchange or Lime and Soda softening plants are employed.

It cannot be stressed too often that 1,000 gallons of water of 1° hardness will destroy approximately 1 lb. of soap, and the equivalent amount of sticky lime soap so formed is liable to re-deposit on the fibre and cause trouble in the after processing.

SCOURING AGENTS

The cheapest and most effective agent for wool scouring is sodium carbonate or soda-ash, which has no deleterious effect on the fibre if properly applied.

Stronger alkalis such as caustic soda are avoided as they cause the fibres to become harsh, discoloured

greater solubility and ease of removal.

The detergent solutions are generally made up to the requisite strengths in a separate room and piped to the various washbowls, the required volumes being checked by meter or other measuring devices.

Soap and soda ash for raw wool scouring have been the most efficient detergents over the years during which sulphated fatty alcohols and numerous synthetic detergents of various chemical types have been marketed for scouring purposes. Recently, synthetic detergents of the nonionic type based on ethylene oxide have become more attractive than formerly for raw wool scouring in place of soap.

The emulsions formed by the use of these synthetic products are stable in acid solutions and this characteristic makes the resultant effluents more difficult to treat by the normal "acid cracking" treatment as carried

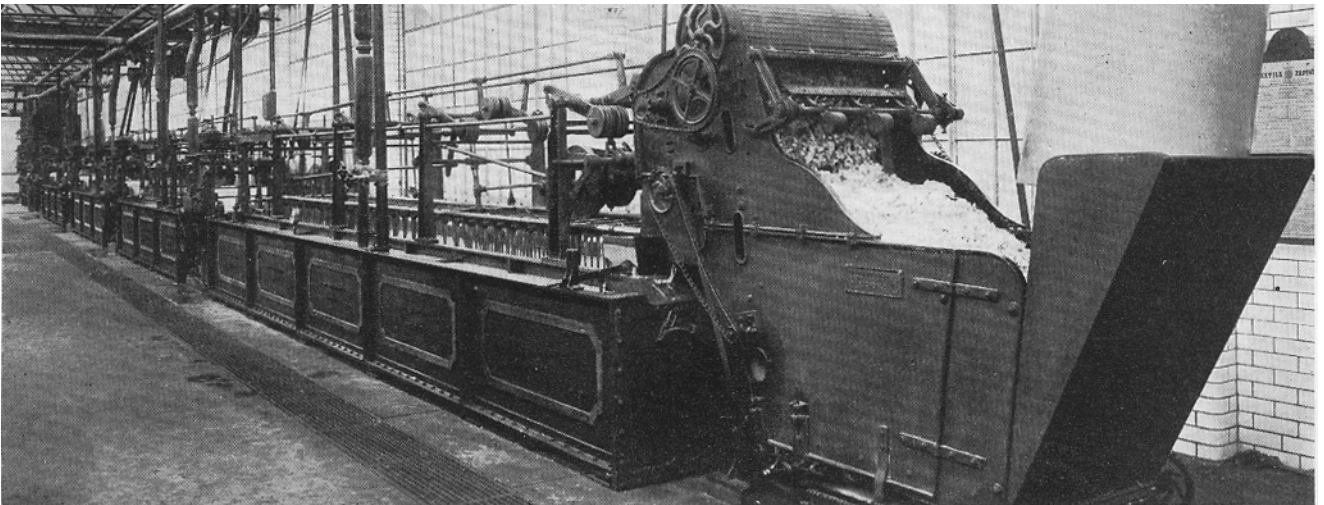

Four-bowl scouring machine with automatic feed.

(Courtesy: Petrie-McNaught)

and even tendered or damaged, particularly at high temperatures. Milder alkalis, such as ammonia, borax and potassium carbonate or bicarbonate, are occasionally used, but they are considerably more expensive, and practical trials show no advantage over soda-ash.

Alkali can be used to a considerable extent in the first (and in some cases the second) bowl, as up to this stage of the processing the actual fibre still has a protective coating of natural wool fat, in addition to which certain salts in the fleece have a limited neutralising action on the alkali. If alkali alone were used, however, the resultant wool would be in a harsh, unsatisfactory condition, and a considerable amount of soap is therefore required to form more stable emulsions and give the wool a lofty and lustrous appearance and handle.

The soaps used must be well made, of a specified strength in fatty acids, or real soap made from fats of good quality, free from rosin, drying oils, fish oils, or low quality bone fat and of low melting point to give

out at various works, so much so that many sewage works authorities are objecting to effluents containing synthetic detergents being discharged into the sewers. It would be a most unsatisfactory position if the development of a scientific discovery of such importance should be held up by a sewage treatment problem, and it is to be hoped that a satisfactory method of overcoming the difficulty will eventually be worked out by collaboration between the manufacturers, the users and the sewage works managements.

SCOURING PROCESSES

The actual scouring process is a matter of emulsion technique, and whilst very many theories have been put forward it is certain that in the particular problem of raw wool scouring there is no generally accepted solution to be found in text books, technical articles or similar sources. The formation of an emulsion may be better appreciated by considering the effect of placing



Scoured wool being conveyed to the dryer.

(Courtesy: Yfag, Norrköping, Sweden)

small droplets of oil on the surface of water. These droplets tend to coalesce, forming larger drops and ultimately a pool due to surface tension. This contracts the surfaces of the oil into as small an area as possible. It follows that the most efficient agent is one that lowers the surface tension, thereby producing more stable and finer emulsions, which can readily be run off from the wool fibres.

Owing to the varying qualities of wool processed, the differences in size and types of washing sets used, detergents employed, "through-put" and general working, it is impossible to lay down any fixed amount of soap and alkali which must be used generally, or to compare consumptions at different works.

At the same time, it is possible by careful trials at individual works to ascertain the most efficient and economical working conditions with regard to the quantity of detergents used (say in lb. per 100 lb. raw wool scoured), the method of additions, temperature, squeeze roller pressures, and so on. Once these standard or optimum conditions have been established, simple regular records ensure that the standard is being maintained, and, what is of equal importance, any falling off in efficiency is noted and the cause ascertained.

Measurements of the effective alkalinity (or pH) of the scouring liquors at various stages of the run, together with occasional chemical analyses of the scoured wool for cleanliness, fatty matters, soap residues, alkalinity are also of assistance in controlling the additions of soap and alkali and ensuring clean scoured wool throughout the run. In many instances simple analyses of the effluents discharged from the bowls for total solids, grease, soap and alkali contents will indicate if the suds are exhausted and whether a full change, a partial change or no change of the scouring liquors is desirable at any particular time. This may, incidentally, effect economies in water, steam, materials and labour, as well as producing the minimum volume of effluent for treatment in the effluent purification works.

There are two other methods which must be mentioned in any survey of wool scouring, namely Suint Washing and Solvent Cleansing.

Suint washing makes use of the well-known detergent properties of the natural organic potash salts

(known as suint) which are present in raw wool. A continuous purification process is incorporated to remove sand, dust and wool fat, and this, with a partial discharge to the sewers, enables a concentrated suint solution to be maintained and re-used. It is claimed that by this method a very considerable economy in soap and alkali is effected.

Many attempts have been made to cleanse wool by the use of organic solvents such as benzene, white spirit, trichlorethylene and so on, but solvent scouring has had limited commercial application. Drawbacks to this system are that the solvents used are either inflammable or toxic, possibly both, and labour difficulties might arise on this account.

Both these methods have been tried out on an extensive scale in this country, but have not met with favour on account of the inferior appearance and colour of the resultant wool, and because the increased cost and complicated nature of the plant might make the cost of processing prohibitive.

BACKWASHING

After the carding process the wool, in sliver form, is given an additional scour termed "backwashing", to remove surface dirt picked up during the mechanical operation of carding and finally to cleanse the fibres. This process is carried out in a two-bowl scouring machine, specially designed for the continuous treatment of slivers. A solution of soap is generally employed as the detergent in the first bowl, and the second bowl contains water only for the final rinsing. As in the original scouring, a drier is incorporated on the back-washing machine to discharge the wool in a suitable condition for the following processes of preparing and combing.

STANDARD OF CLEANLINESS

The standard of cleanliness required is generally recognisable in the trade and incorrectly scoured wool is readily detected, both by its appearance and by the manner in which it goes through the various mechanical processes. Any failure to reach the necessary standard would soon be noticed and corrected by the operatives and management concerned.



CARDING

WOOL

FOR

WOOLLEN

YARNS

*P. P. TOWNEND,
Ph.D., F.T.I., Senior Lecturer in
Yarn Manufacture, University of Leeds*

IF one takes a handful of greasy wool fibres and washes them in warm soapy water, then at least two things happen: first, the fibres lose their dingy appearance and become white; and second, what was previously a series of locks of fibres, each lock consisting of a series of parallel fibres, now takes on the form of a jumbled mass, the fibres being wound round each other. The tightness of the fibres depends on the degree of friction used in washing. This second point is extremely important because it is very difficult to spin fibres into

yarns when they are entangled with each other. But the washing process is necessary to cleanse greasy fibres, and so the carding process, which disentangles these fibres and arranges them in a much more orderly fashion, is just as necessary.

FUNCTIONS OF THE CARD

In the conversion of wool to yarns and cloth, it is the practice to blend together wools from different sources, each wool being more or less the same quality so far as

fibre diameter and length are concerned. This is done in order to maintain more easily a standard quality of yarn, for if wool from a certain source should not be procurable in any one year, then it is easier to substitute a part rather than the whole and yet maintain the same quality of cloth. Therefore, another function of the carding machine is to help mix fibres from the various constituents of the blend, so that they are uniformly distributed in the subsequent yarns. Before carding, the different wools are mixed in a teasing machine, but this operation only mixes locks of different wools, and one relies on the card to achieve the actual mixing of the fibres. This uniformity of fibre mixing in the yarn is important because it governs such properties as yarn diameter, strength, extensibility and shrinkage, for it will be realised that unless the yarn is uniform, one cannot expect it to possess uniform properties.

It is not only white wools that are blended together. Many cloths are produced by mixing together coloured fibres, a simple example being a grey woollen flannel consisting of black and white fibres. The carding machine is here again responsible for the intimate fibre-fibre mixture which is essential if the garment is to possess a uniform appearance.

So far, then, it has been shown that the card disentangles the fibres from the different locks of wool, and, at the same time, blends these disentangled fibres to produce a uniform mixture. This may apply to different types of fibre each of the same quality and also to different coloured fibres.

The third function of the card is to produce a uniform web of fibres and then to divide this thin web, which extends across the full width of the card, say sixty inches, into a number of narrow webs about half an inch wide. Each narrow web is then rolled into a circular sliver, known technically as a condensed sliver. Since the web is endless for as long as the card functions, it will be seen that a number of endless condensed slivers is produced. These are wound on to wooden barrels, and removed from the card at intervals to go forward to the mule or ring frame, which converts the condensed slivers into yarns.

HAND CARDS

Before 1748, carding was effected by the use of hand cards (Fig. 1). These consisted of two boards on which strips of leather were fastened, and in which wire teeth were inserted. The wire teeth were inclined, in order to bring about the carding action. Tufts of wool to be carded were laid on the one board and the one was pulled across the other in such a manner that the points of the two sets of teeth opposed one another (i). This "point to point" action was repeated several

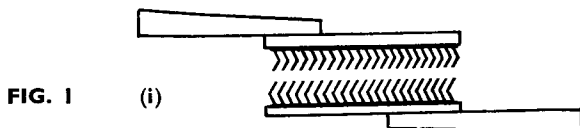

FIG. 1

(i)

times until the wool locks were sufficiently disentangled, after which the top card was turned through 180°, so that the points of the latter now stroked the backs of the bottom teeth and therefore effected a stripping action (ii). When the two cards were rubbed together in this fashion the carded wool eventually dropped out in the form of a roll which could then be drawn and spun. In early times this was achieved by the drop spindle and later by the spinning wheel.

CARDING MACHINES

In 1738 Paul, a London shroud maker, dissatisfied with the quality of hand-spun yarns, invented a spinning machine which he claimed would "spin yarns

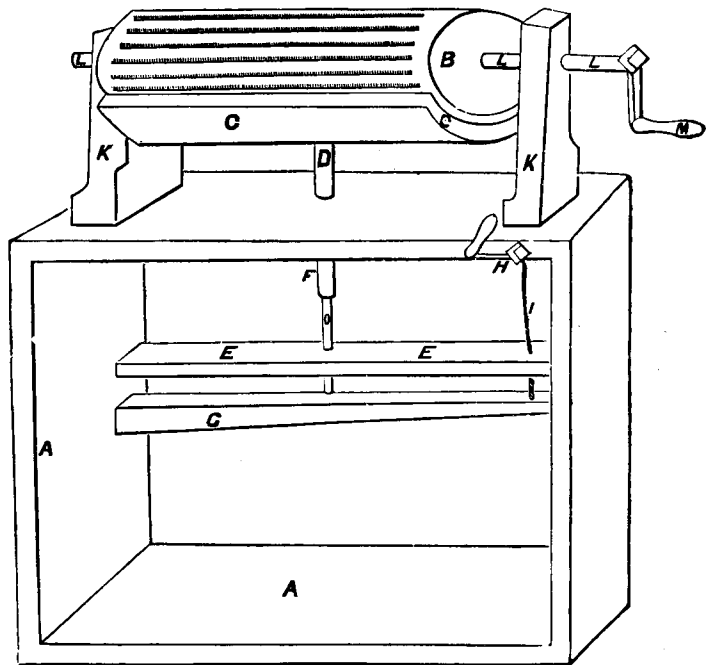
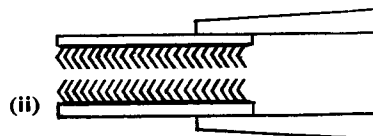

FIG. 2 Paul's Carding Engine.

(Courtesy: The Textile Institute)

of more uniform count and twist". This invention is important, because the increased production of the spinning machine emphasised the need for something better than the leisurely methods of hand carding. Thus the invention of the spinning machine led to the original patents for carding machines. In 1748 a certain Daniel Bourn, who had a cotton mill at Leominster, in Herefordshire, patented the first carding machine. The specification reads: "The properties by which this machine of carding differs from any other method hitherto invented are principally these; that the cards are put upon cylinders and that these act against each other by a circular motion and that they may be moved either by hand or by water-wheel." In the same year Paul invented two cards, one of which was probably the forerunner of the cotton card.



(ii)

The other was based on roller carding, and, like Bourn's, required far less manual labour than did the hand cards. In this machine (Fig. 2) the material had to be placed in the machine, carded and then taken off the machine; in other words the process was discontinuous. It is thought that Arkwright was responsible for converting the process to a continuous one, firstly, by the invention of a pair of fluted feed rollers which passed the material into the machine; secondly, by the introduction of a doffer to take the

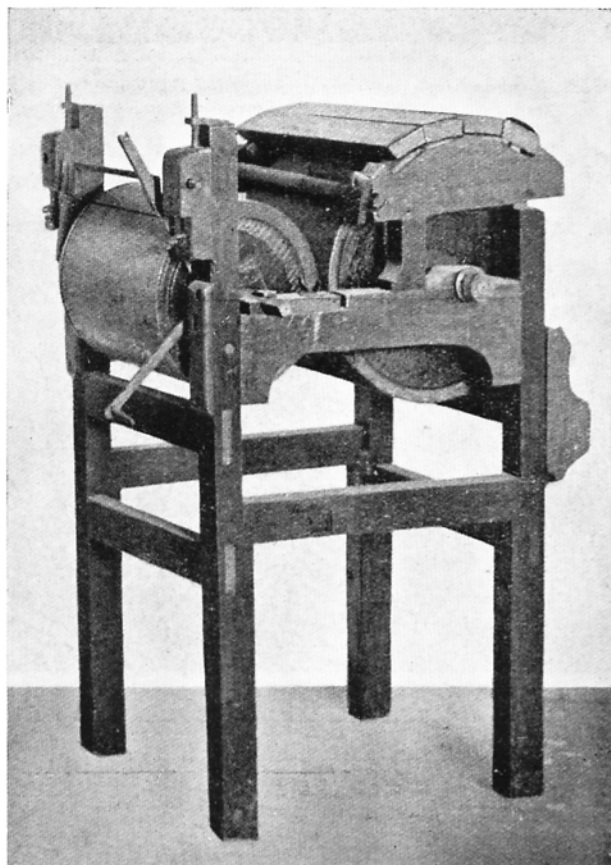

FIG. 3 *Arkwright's first carding machine.*
(Courtesy: The Textile Institute)

material from the carding cylinder; and finally, by an oscillating comb which removed the fibres from the teeth of the doffer in a continuous web-like form. Arkwright's first card is shown in Fig. 3, and a later model in Fig. 4. The latter was used at the end of the eighteenth century for carding cotton, but the similarity between this machine and the one used for carding wool in the Stroud district of Gloucestershire about 1815 indicates that the main principles of machine carding had by then been established.

METHODS OF CONDENSING

In those days, the web of fibres removed from the doffer of the machine consisted of strips some five inches

wide and the length of the machine. These slivers were joined together end to end by hand and reduced in diameter by the slubbing-billy, after which the rovings were spun to yarns by the mule, which in those days would be Hargreaves's Spinning Jenny. By 1821, however, this method of condensing was replaced by the invention of the single ring doffer. In this case the rings of card clothing, instead of extending across the roller, were wound round it. The rings were about an inch wide and separated from each other by a ring of plain leather, and as the doffer rotated it took from the swift a series of endless slivers, each being, of course, one inch wide. These were stripped from the doffer by a comb, and then made to pass between a pair of endless leather bands, which rubbed them into circular

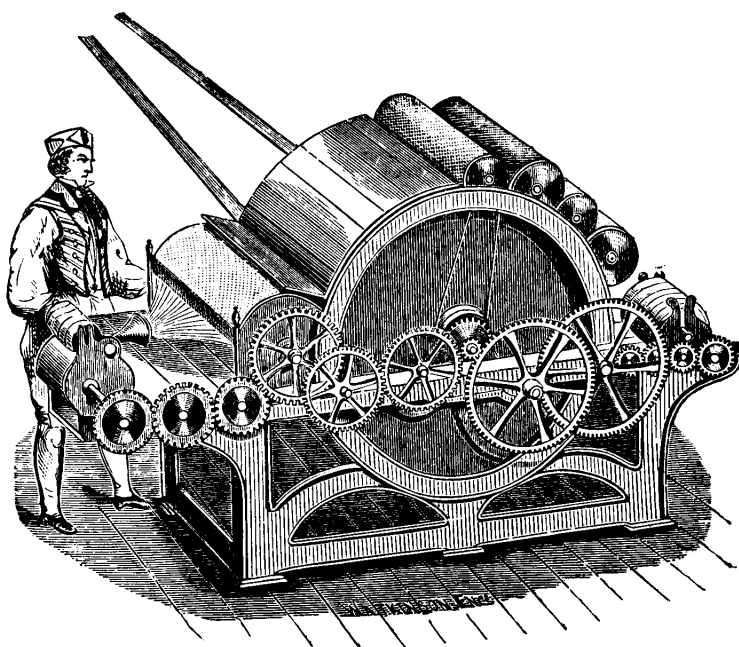

FIG. 4 *Arkwright's later carding machine.*
(Courtesy: The Textile Institute)

slivers preparatory to spinning. It will, of course, be realised that this doffing device only removed that material from the swift which happened to be opposite to the strips of card clothing; the remainder opposite the leather strips was not removed. This unproductive method was overcome by the introduction, in 1825, of the double doffer condenser, where the whole mass of fibres on the swift was removed by placing one doffer over the top of the other. Each doffer was clothed across by successive rings of card clothing and leather, but the strip of clothing on the top doffer was arranged to be immediately over the bottom doffer's strip of leather. Both these methods of condensing are still used, along with a third method, that of tape condensing, which was introduced about 1861. In this

system, the web of fibres is removed from the last swift in the card by a doffer covered entirely with card clothing, and this web, the full width of the card, is then passed forward between a series of narrow endless strips of leather, called tapes. These tapes split the web from the card into slivers the width of the tape, say half an inch, and these pass forward to the rubbing mechanism, where they are transformed into the circular sliver suitable for spinning.

AUTOMATIC FEEDS

Up to this time the wool had been fed to the card by hand, weighed amounts being spread evenly on the feed sheet of the machine between marked lathes equally spaced apart. But the introduction of the condenser systems, especially the tape condenser which produced much finer slivers, emphasised the need for some automatic feed. This device, patented in 1860, simply consisted of a hopper capable of holding a large quantity of wool, which was carried forward by a spiked lattice to a scale-pan from which weighed amounts were dropped at fixed intervals of time on to the feed sheet.

CARDING PROCESSES

In a modern carding machine the automatic feed passes a more or less uniform stream of wool forward to the feed rollers of the machine. From there it is carried forward by the main cylinder (Fig. 5, B) to undergo the disentangling action between this cylinder and the first worker (A). Some of the material goes forward, whilst the rest, caught by the worker, passes round the latter's circumference, from where it is removed by the stripper and again placed on to the main cylinder to go forward again (Fig. 6). It will be seen that the disentangling action also brings about a mixing of the various qualities or colours in the blend, for the wool, placed back on to the cylinder by the stripper, obviously joins up with other fibres which come on at a later stage. Each cylinder has some four to eight pairs of workers and strippers placed over it, so quite a lot of disentangling and mixing takes place over the one cylinder. But obviously there is a limit to the amount of carding which can be achieved by the one swift, for at each worker-cylinder action some of the fibres are pushed between the teeth of the swift and then are unable to take part in the subsequent carding actions. Consequently the material, after its passage past the four to eight workers, is raised by another roller called a fancy (Fig. 7). The teeth of this roller act like a brush and raise the fibres to the surface of the swift's teeth, from where they are removed by the doffer. This roller passes the fibres forward to a second swift, where further disentangling and mixing is accomplished by another set of workers and strippers. A

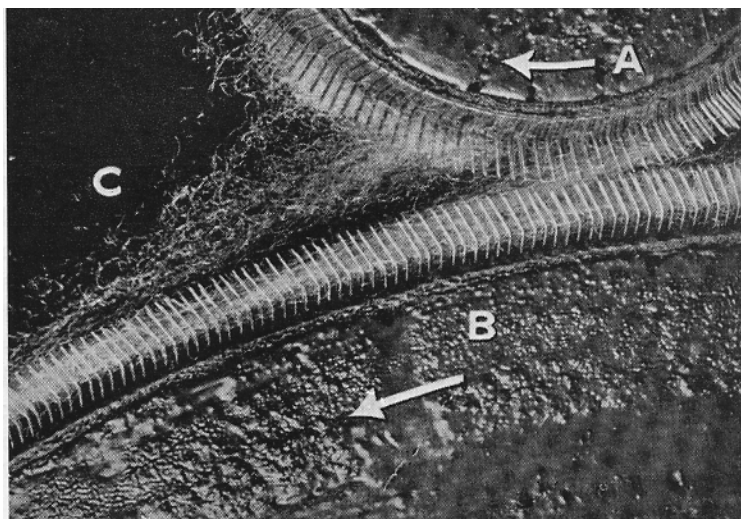
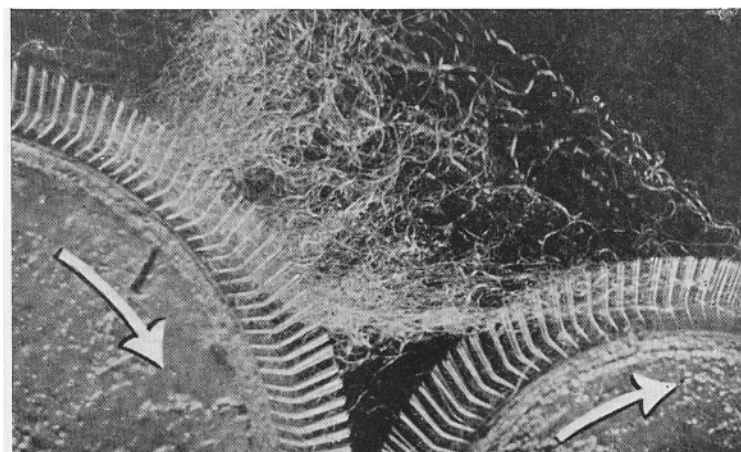

FIG. 5 *Carding Machine — the action of the Worker.*
(Courtesy: Wool Industries Research Association)

FIG. 6 *Stripping the Worker.*
(Courtesy: Wool Industries Research Association)



modern carding machine consists of some three to six swifts, each with its attendant workers, strippers, fancy and doffer (Fig.8).

In order to achieve a gradual disentangling of the fibres throughout the machine with a minimum amount of breakage, the density of pinning on the

FIG. 7 *The action of the Fancy.*
(Courtesy: Wool Industries Research Association)



various rollers is graduated throughout the machine. It is coarse at the commencement and fine at the end of the machine, and the spacing between the rollers is also graduated; for example, the distance between the wires of the swift and workers might be about 1/50 inch in the case of the first swift, and 1/100 inch in the case of the last swift.

After the fibres have passed through the first two or three swifts of the card, the web is stripped from the last doffer, and conveyed in a sliver form to another feed sheet, on to which it is laid at right angles to its forward motion into the second half of the carding machine. This break in the continuity of the card is known as the intermediate feed, and is designed to reduce any variations in uniformity of feed to the card. One cannot be sure that every weighing of material is exactly alike, and so this break in the machine with its consequent rearrangement and doubling of the slivers does compensate for this deficiency. At the same time the intermediate feed helps to mix the fibres.

PRODUCTION OF SLIVERS

The fibres then pass through the second half of the machine, which again consists of swifts with their attendant workers, strippers, fancy and doffer, until they reach the last doffer of the machine. From here the web of fibres is removed by a doffing-comb, or stripper, in a thin web extending the full width of the machine, say sixty inches, and passed to the condenser, whose function is to split up this web into a series of narrow webs, say half an inch wide. Each web is then converted into a circular sliver and wound on to a wooden bobbin ready for spinning (Fig. 9). The tape condenser, which is probably the most common type, consists of two series of endless leather bands arranged side by side. The top series of bands pass to the bottom of the machine whilst the bottom series pass to the top of the machine and at the same time the web of fibres from the back doffer is fed to the point of intersection of the tapes. Thus the web is divided up into a number of narrower webs, the width depending on the width of the tape and the number of ends corresponding with the number of tapes. In a modern machine a sixty-inch web can be split up into 240 ends, each being, of course, a quarter-inch wide. The web of fibres which lies on each tape is then removed from the tape and passes between a pair of oscillating leather aprons. These aprons have two motions; in the first place they pass the web forward, but at the same time they have a lateral movement which rubs the web into a circular sliver, and the web enters the rubbing aprons in a rectangular form and leaves them in the form of a circular sliver. There is no twist in the slivers. They hold together because of the fibrous nature of the material. Finally, the condensed slivers are wound on

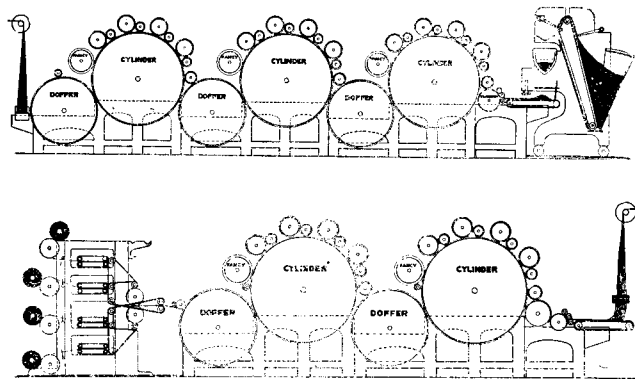
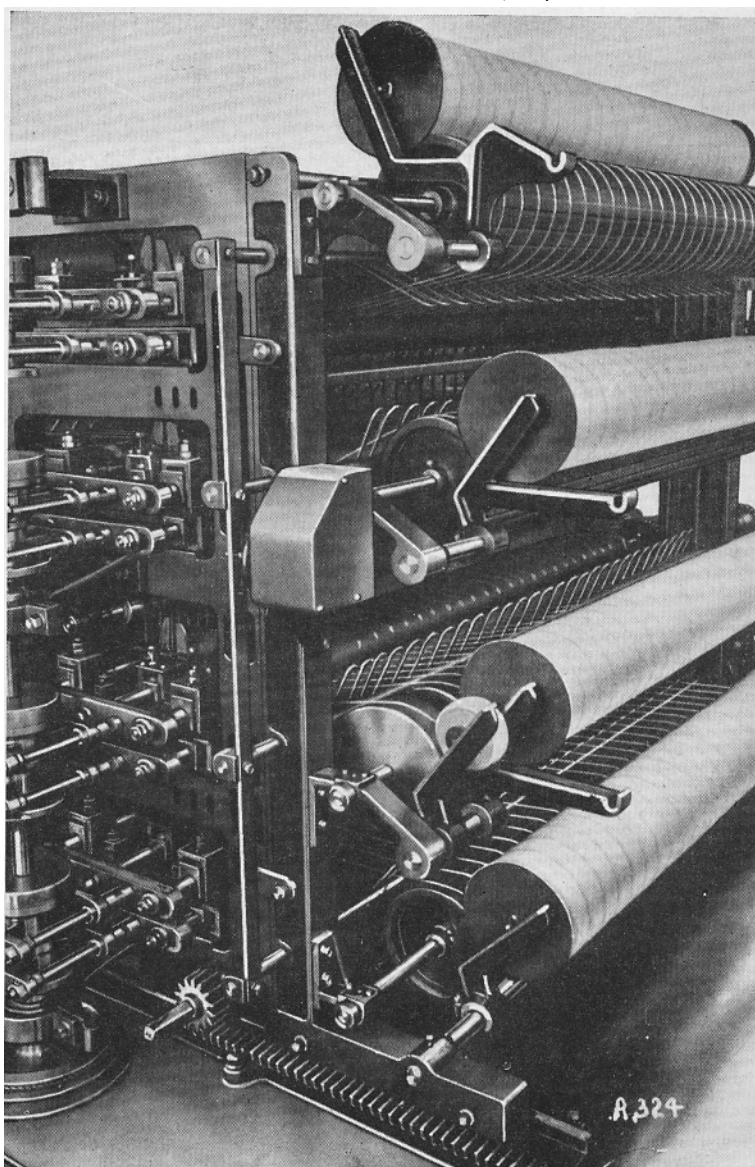

FIG. 8 *Modern Carding Machine.*
(Courtesy: Messrs. Platt Bros. (Sales) Ltd.)

to bobbins, side by side, perhaps twenty to thirty on a bobbin, and taken to the spinning machine for conversion to a yarn. In this process the condensed sliver is reduced in cross-sectional area, and at the same time is twisted to impart to the yarn sufficient strength for the subsequent operations of winding or warping and weaving.

FIG. 9 *Circular slivers wound on to bobbins.*
(Courtesy: Messrs. Platt Bros. (Sales) Ltd.)





Slivers from the condenser at the end of the carding machine are being wound on to the condenser bobbins. There is no twist in the slivers, and the fibres would part under tension.

THE SPINNING OF WOOLLEN YARNS

*J. G. MARTINDALE, B.Sc., Ph.D., A.Inst.P., F.T.I.,
Principal, The Scottish Woollen Technical College, Galashiels*

THE preceding article has described how wool is carded, how the thin veil-like web of carded wool is split up into narrow sections, each about half-an-inch wide, which are then rubbed with a lateral movement by rubbing aprons – in the same way that the pipe smoker rubs up his charge of tobacco and for the same reason – to give the short fibres some cohesion. In the case of wool this produces continuous, soft, spongy, untwisted strands called “slivers”. The process of carding and sliver formation is the immediate precursor to the spinning operation, in which these fragile slivers are converted into strong woollen yarns.

In principle at least, the conversion is quite simple; one end of the sliver is spun round, that is, it is twisted. This twist increases the inter-fibre cohesion by binding

the fibres together and so produces a strong yarn. For a reason to be given later the strand is drawn out and made thinner during this spinning process, its length usually being increased by about 50 per cent. The binding of the fibres by twist, as well as the drafting which occurs, changes a sliver of about $\frac{1}{6}$ or $\frac{1}{8}$ inch diameter to a yarn of about $\frac{1}{25}$ inch diameter or less. These dimensions, of course, vary according to the type of yarn being spun, but are typical of the change which takes place.

Stated in this way the operation sounds fairly simple, but, in fact, it is quite complicated to carry out in practice. The spinning mule which does it is one of the most complicated machines in the textile industry – it was developed from the spinning jenny patented by

Hargreaves in 1770. In addition, the behaviour of the fibres in the strand during the conversion from sliver to yarn is not at all clearly understood and the adjustment of the mule to the needs of different wools calls for a great deal of skill on the part of the spinner, whose ability can be acquired only by his long experience of mule spinning.

THE FORMATION OF A WOOLLEN YARN

The fibres in the sliver are entangled in a random kind of way as they were arranged by the carding machine in the card web. The rubbing which they then receive rolls them together more intimately and so they hold together more effectively. This gives the sliver a unity which enables it to withstand winding on to the condenser bobbin and which will next enable it to be unwound in order to be spun. It will not stand any tension, however; if submitted to tension it will break because the softly adhering fibres will just slip apart. In consequence it must first be twisted slightly before it can be drawn finer.

The first operation of conversion into yarn is there-

fore to take about four feet of sliver and to twist it slightly. Tension is then applied and the sliver is drawn out to a longer length. This "drafting" or stretching takes place by fibres at various places along the length of the strand slipping over one another. The twist inserted at this stage must therefore not be too great or the fibres will be bound so tightly together that instead of drafting the strand will snap. On the other hand, the twist must not be too small or there will not be sufficient cohesion at some points and the strand will again break by fibres parting company altogether at these points.

All slivers are irregular in thickness along their length and it is known that when twist is inserted it concentrates in the thin places. Thus the fibres in the thin places have more cohesion than those in the thick places, and when drafting takes place it is at the thick places that the slippage occurs and consequently the thick places become thinner. This explains why drafting is resorted to in making a yarn. A fairly strong yarn could be made simply by putting enough twist in a sliver, but it would be a comparatively irregular yarn and the thick places would have a tendency to be

Woollen Mule. On the right of the machine are the condenser bobbins, from which the slivers pass between two feed rollers to the spindles in a row beneath the hands of the spinner. The spindles are mounted on a movable carriage running on rails to and from the bobbins. The curved arms bearing the yarn guides can be seen above the spindles.

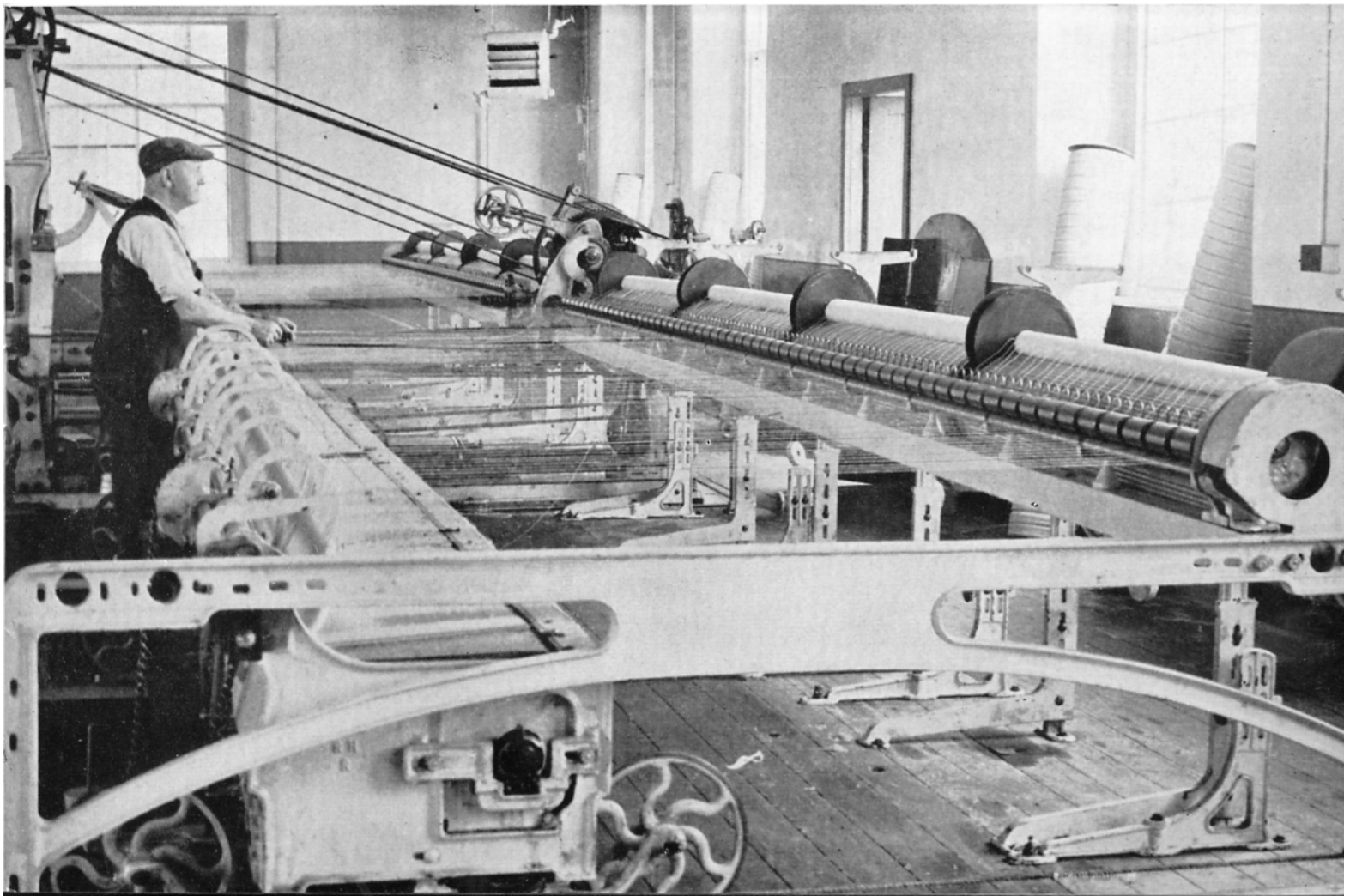

weak. As drafting works preferentially on these soft, thick places and draws them down, it produces a more uniform strand and, ultimately, a comparatively strong yarn is produced.

As drafting proceeds and these soft places become thinner, they would again slip apart if not further reinforced, so that twist must be added continually whilst drafting is going on to give sufficient fibre cohesion at all points. All the time, however, it must be graduated so as to avoid excessive fibre slippage on the one hand or excessive fibre grippage on the other, either of which would result in the breakdown of this embryo yarn.

Whilst drafting is taking place, therefore, one can picture the fibres continuously in motion. Cohesion here prevents slippage in this place; there softer places give way, slip and become thinner; extra twist is put in which reinforces these thinner places; other places then slip and so there is a continual state of flux, first one place than another responding to the draft, the result being a more uniform strand.

It will, therefore, be seen that draft is being applied against the controlling effect of twist, which produces

fibre cohesion, and although the exact conditions are not known, it appears that the best yarns are produced when the right balance is struck between fibre slippage and fibre grippage. It follows that the frictional properties of fibres and the way they may be affected by lubricants such as oil or other treatments which the wool has received before carding, must be very important.

There is, inevitably, from what has been said, a limit to the amount of drafting which can be done. If it is exceeded many yarn breakages will occur. In very favourable circumstances the sliver can sometimes be drawn out or drafted to double its original length, but an increase in length of 50 per cent is more usual; that is, the original four foot length of material becomes six feet long. At the conclusion of drafting we therefore have a six foot length of drafted, twisted sliver, but although it is much finer and more compact than the original and looks like a yarn, it is still not quite a yarn in the sense that the spinner uses the term. Up to this point fibre slippage must have been possible to permit of drafting and, if now submitted to a moderate tension, the fibres in the strand will slip somewhere and the

Close-up of the spindles. The yarn, directed by the two yarn guides, is being wound on to each spindle in a cylindrical layer to form the bottom of the cop. With succeeding layers this will become cone-shaped at the top.

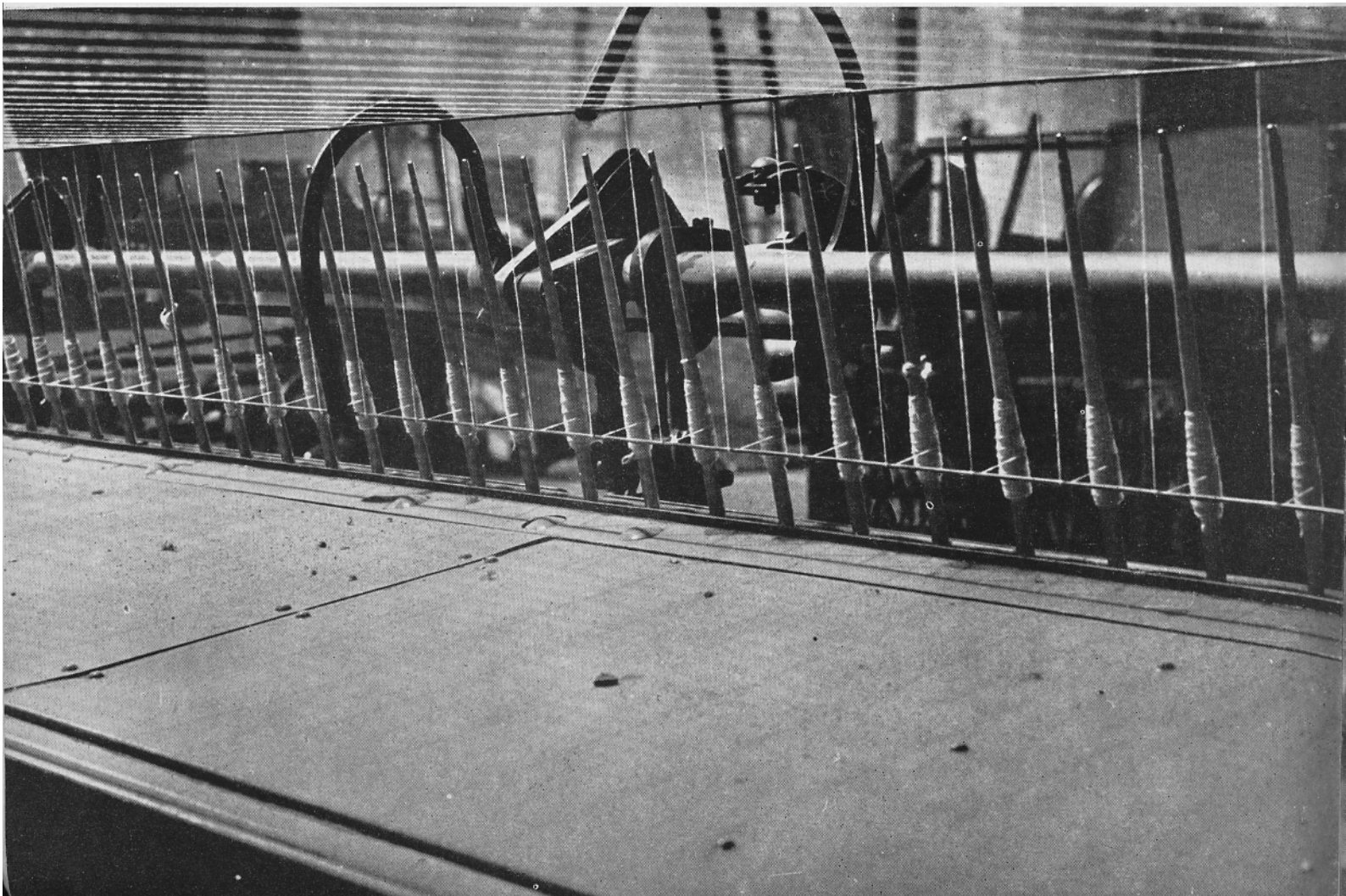

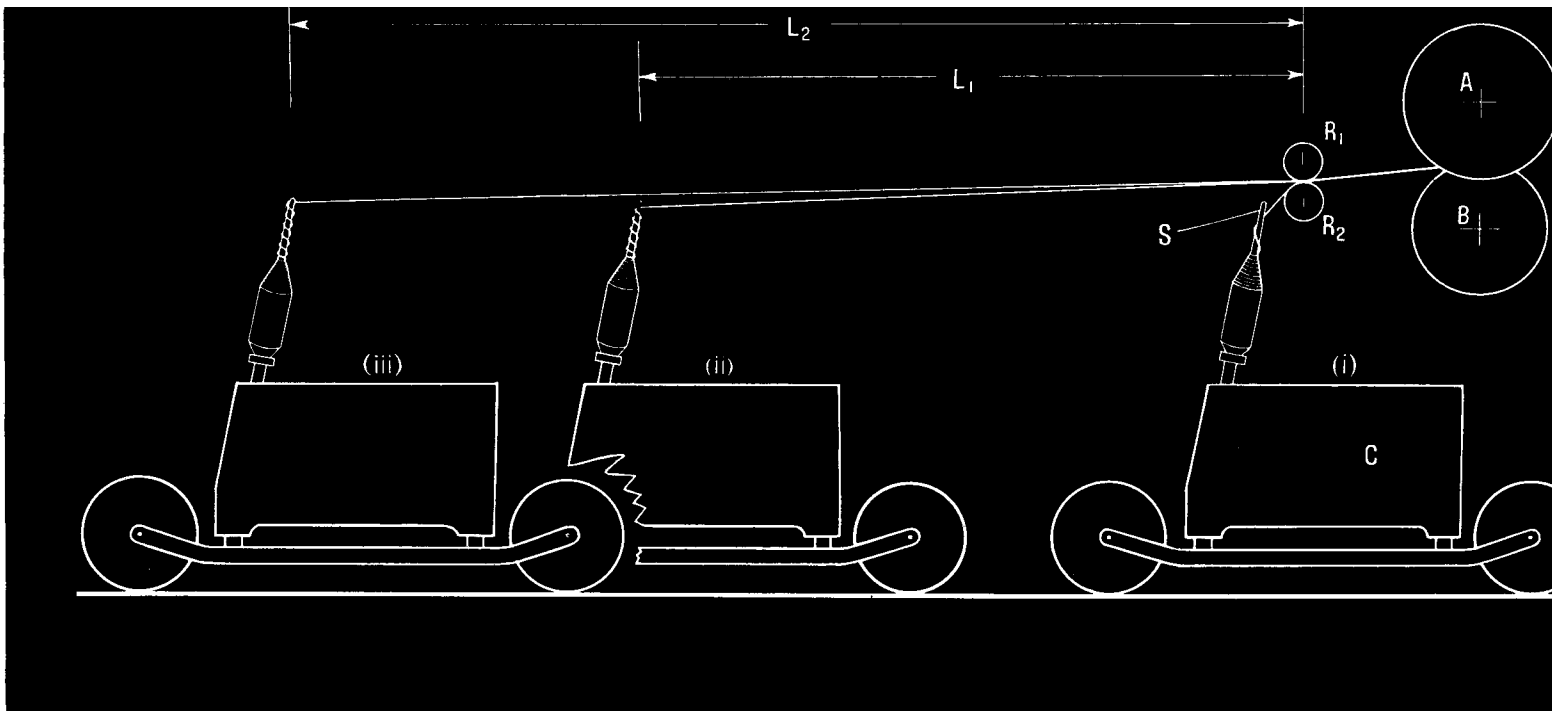

FIG. 1 Cross-section of Mule, showing the movable carriage in three positions.

strand will break. It is too soft to be a good yarn so additional twist is put in, without any further drafting, and the fibres are bound tightly together; fibre gripage will now predominate and before the yarn will break we must actually break some fibres. The yarn is therefore quite strong and when it does break it will break with a good snap.

Yarn spinners are interested in making the best possible yarn from a given sliver and the scientific observer would think that one would have the best chance of doing this if one knew exactly what the fibres were doing and how they were being rearranged whilst this twisting and drafting was taking place, as then conditions could perhaps be arranged to produce the best results. As we have remarked, very little is known about the exact behaviour of the fibres or how they react to changing circumstances so that, although the general principles of making a yarn are simple, consideration of how to produce the best possible yarn is much more obscure. Perhaps one ought to explain what is meant by the phrase "how the fibres react to changing circumstances". It should be remembered that oil is put on wool before carding and it is still present in the sliver to be spun; different oils can be used and various amounts can be applied; fibres may be undyed or they may have been dyed and this affects their physical properties; the sliver may be drafted to different extents up to about 100 per cent. These are all various circumstances, which may have an effect on how the fibres behave during spinning and so affect the quality of the yarn made. Add to this the fact that there are many different kinds of wool, which

react to the process in different ways, and one must realise that as yet spinning is very much more an art based on experience than a science.

THE OPERATION OF THE SPINNING MULE

We now know the procedure for making a yarn and, setting aside the debatable question of how the fibres react to the process, we can at least see how it is carried out on the mule. Look at Figure 1. Here the condenser bobbin A which has been brought from the card, and on which many slivers have been wound side by side, is mounted on brackets and rests on a circular drum B. The ends of the slivers are unwrapped, are passed between a pair of feed rollers R_1 and R_2 , and each is attached to the bottom of a spindle S, these spindles being mounted in a row on a movable carriage C in position (i).

If we consider one typical strand only, what happens is this. The drum B and the feed rollers R_1 and R_2 rotate at the same surface speed so that the sliver is paid out from the bobbin and is delivered by the rollers to the spindle. At the same time the spindle carriage moves out and away from the rollers at the same speed as the material is fed to it, and the spindles begin to revolve and twist the sliver. This brings the carriage to position (ii), the slightly twisted strand is coiled round the spindle from bottom to top in spiral form and extends from the spindle tip to the "nip" of the feed rollers where it is firmly held. At this point the drum B and the feed rollers stop, and the length L_1 of the strand is ready for drafting.

The strand is now being gripped at one end by the

feed rollers and at the other end is being spun round by the spindle, to which it is attached and which continues to revolve after the feed rollers have stopped. At the same time, although the carriage C slows down, it continues to move out to position (iii) where it stops. Thus between positions (ii) and (iii) the twisted sliver is drafted to a longer length L_2 . After the carriage has reached this furthestmost position no further drafting takes place, but the spindles increase to their full speed and put in the additional number of turns of twist required to form the yarn. The full extent L_2 is usually 72 inches so that if twenty turns of twist are required per inch of yarn the number of turns in L_2 will be built up to 1,440. Now as the strand is twisted to this extent it shortens, or, if both ends are securely held, the tension in it increases considerably. This would lead to the end breaking if the tension were not relieved, so the spindle carriage moves in an inch or two to accommodate this effect as the full twist is built up. This is called "jacking in".

The length of yarn having been fully spun the spindles stop. They then make a few revolutions in the reverse direction; this is known as "backing off" and serves to unwind the few coils of yarn wrapped round the spindle. The carriage then runs back to position (i) and whilst this is happening the spindles make a few turns in the original direction of rotation and wind the yarn on to themselves *en route*. At the same time yet another mechanism comes into operation to operate a pair of yarn guides on the carriage (not shown in Fig. 1) which lead the yarn on to the spindle in such a way that a nicely shaped cop is formed.

Some idea of the complex mechanical provisions which need to be made may be gained from the following summary:

- (i) The feed rollers and drum B must run at the same surface speed, intermittently and exactly in step.
- (ii) The carriage must start on its outward journey as the feed rollers start up; it must slow down when they stop; move to the full extent; stop; move in slightly as the yarn tightens; stop for backing off; and finally return at the right time.
- (iii) The spindles revolve at a constant speed whilst the sliver is being delivered and drafted; accelerate to full speed when the carriage is right out; stop when full twist has been provided; reverse for a few turns to unwind the yarn wrapped round them and rotate slowly at the right speed and in the original direction as the carriage runs in and stop when it is fully in.
- (iv) The yarn guides must operate mechanically up and down, guiding the yarn to build up in layers on the conically-shaped nose of the cop when winding on is taking place.

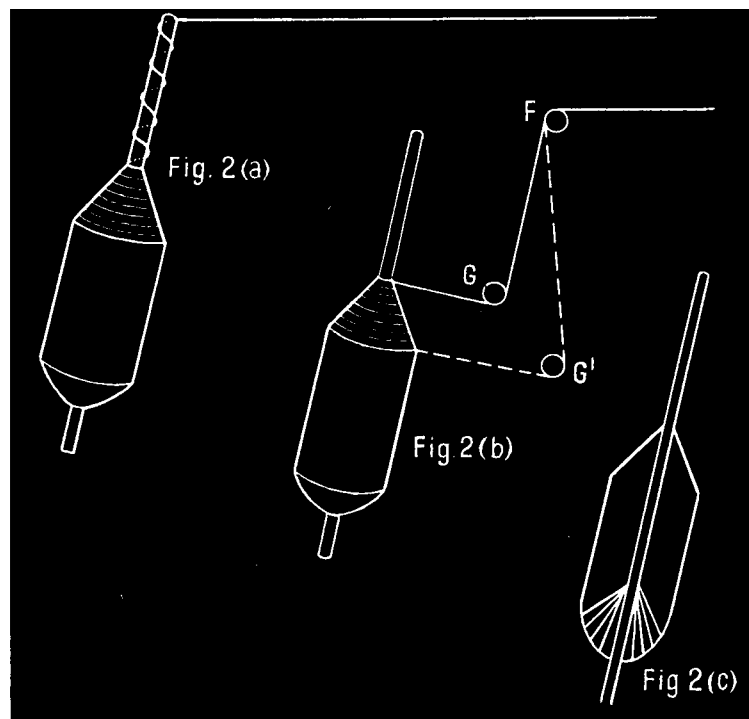

FIG. 2 Forming the cop of yarn on the spindle:

- (a) side view of spindle, with half-formed cop, before "backing off";
- (b) side view after "backing off";
- (c) cross-section showing the building-up of the cone shape of the cop.

In a short article like this it is impossible even to give a brief description of all the complicated mechanisms required to perform these many movements, and when it is realised that they must all take place in perfect harmony with each other it must be evident that the man in charge of spinning mules has to be an extremely knowledgeable and skilful person.

Perhaps one example will show the complexity of some of these operations.

Fig. 2(a) shows a spindle on which a cop of yarn has been partially built. The yarn is spiralling upwards towards the spindle tip from which it stretches to the rollers, the position being that at the end of spinning and before winding on. This six foot length of spun yarn has now to be wound on to the conical top of the partly-formed mule cop to make the next layer. As already explained the first step is to "back off", that is, remove the few coils of yarn round the spindle by rotating the spindle the requisite number of times. Note, however, that as spinning continues the cop gets larger and the length of bare spindle shorter so that fewer coils are present on it. Therefore the number of turns which the spindle has to make to back off grows continually smaller, which adds another complication to the mechanism controlling the spindle drive.

Fig. 2(b) shows the situation after this yarn has been uncoiled, but now for the first time the two yarn guides F and G have been introduced into the picture. As the carriage runs in, G first falls quickly to G^1 and so

wraps a steep spiral of yarn on the top of the cop. This spiral falls steeply from nose to shoulder and binds the previous layer tightly in position. Having done this the yarn guide at G^1 then rises slowly to its original position and builds up another spiral of yarn as the carriage runs in. It will be seen that if the carriage runs in at a constant speed – taking in yarn at a constant rate – then the spindles must revolve slowly at first when yarn is being wound on at the shoulder and must speed up gradually as coils of decreasing diameter are formed towards the nose. This would be a problem in itself, but the carriage cannot run in at a constant speed; it has to be accelerated to begin with to get it moving and has to slow down gently to a stop when coming towards the end of its inward run. Then consider that this is the situation only when the cop shape has already been established. To begin with one has to wind on to a bare spindle and start with a cylindrical layer, Fig 2(c). Succeeding layers produce flatter and flatter cones until the bottom of the cop has been made. Thus the spindle motion, which is complicated enough even when the required conical nose has been formed, is even more complicated when these ever-changing layers at the bottom of the cop are being built to give the required shape, and the mechanisms controlling the motion of the yarn guides and variation of spindle speed have to be regulated accordingly.

One cannot describe mule spinning without becoming more and more involved in complicated motions, and what is even more remarkable is that they are capable of being so delicately adjusted in relation to one another. They have to be, or else the yarn would either be so slackly wound on the one hand that the cop would fall to pieces, or so tightly wound on the other hand that the yarn would break. As one writer has said, “the more one understands the difficulties that are involved, the more wonderful does the action of the mule become”. And again, “the more one knows about a mule, the more one wonders that its inventors ever succeeded in making it work”.

There is another machine – the woollen ring-spinning frame – which can be used for making woollen yarn, but in spite of its simplicity by comparison with the mule it is doubtful whether five per cent of the woollen yarn production in Great Britain is made on this type of machine. In this country the mule is by far the more popular of the two for making woollen yarns, because it is more versatile and spinners believe that it makes the better yarn.

According to the Commonwealth Economic Committee there were over two million two hundred thousand mule spindles in operation in Great Britain in 1952 and according to the Board of Trade, 315 million lb. of woollen yarn were spun in 1953.

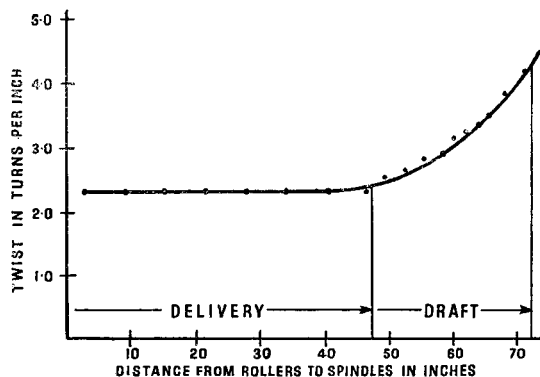

FIG. 3 During delivery the constant carriage speed and constant spindle speed maintain a constant twist of 2.3 turns per inch. During the drafting stage the spindle speed remains the same, but as the carriage slows down the twist increases to 4.2 turns per inch. Drafting then ceases.

(Courtesy: J. A. B. Mitchell)

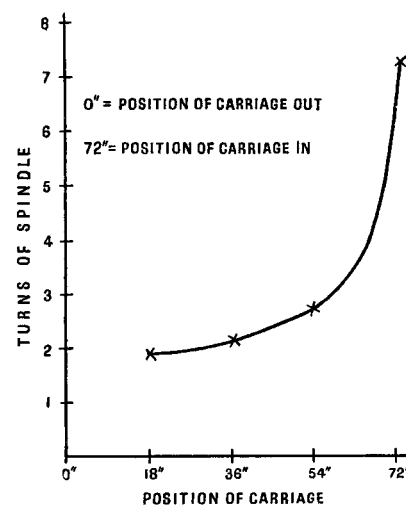
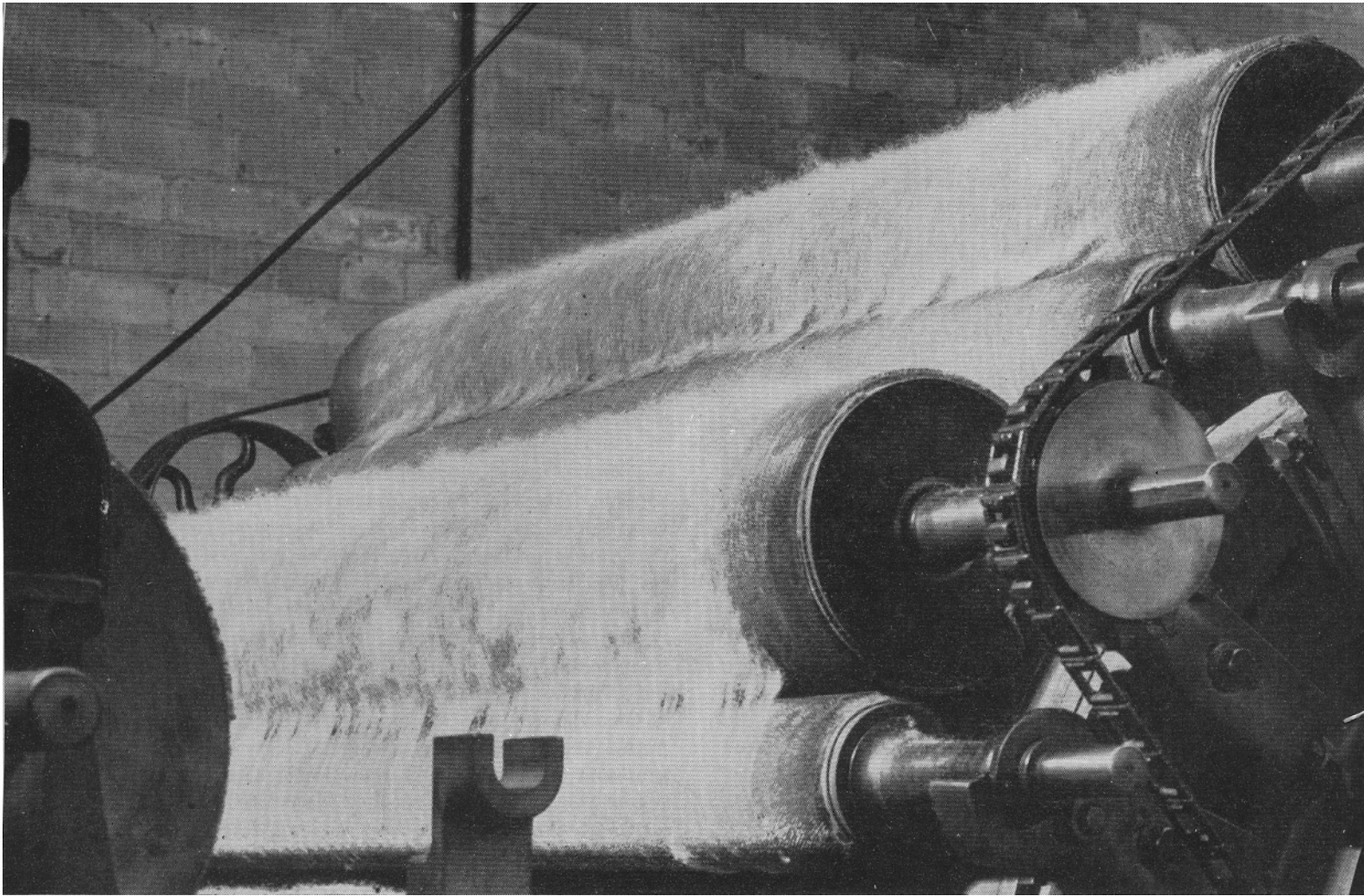

FIG. 4 Graph showing the number of turns of the spindles during four successive equal sections of the run-in of the carriage during winding on. As the carriage comes in the spindles must make increasingly more turns to wind on equal lengths of yarn.

(Courtesy: J. A. B. Mitchell)



CARDING WOOL FOR WORSTED YARNS

*P. P. TOWNEND, Ph.D., F.T.I.,
Senior Lecturer in Yarn Manufacture, University of Leeds*

WORSTED yarns are made from virgin wool fibres. The wool must first of all be sorted, and in this process the many fleeces which go to make the blend are each divided, and portions having the same fibre characteristics of fineness and length are assembled to form a pile. In practice, it would be impossible to get together a sufficient quantity of wool for the one pile from one type of wool, and wools of the same quality but different types are often blended together at this stage. The blending process is followed by scouring and drying, to rid the wool of its fat, suint and dirt. The clean, moist wool then passes through one of two processes; it is either "prepared" or "carded". The

choice is determined mainly by the fibre length; if this is longer than seven inches it is prepared, if shorter it is carded.

PREPARING PROCESS

In the preparing process the tangled clean wool is passed through a series of gilling machines, usually six, before it is combed. Each gill-box contains a pair of feed rollers which pass the wool forward to be partially straightened by a number of steel-pinned fallers, which rise up before the rollers and penetrate the material fed forward by the rollers. Having penetrated the fibres, the fallers move away from the rollers at a greater

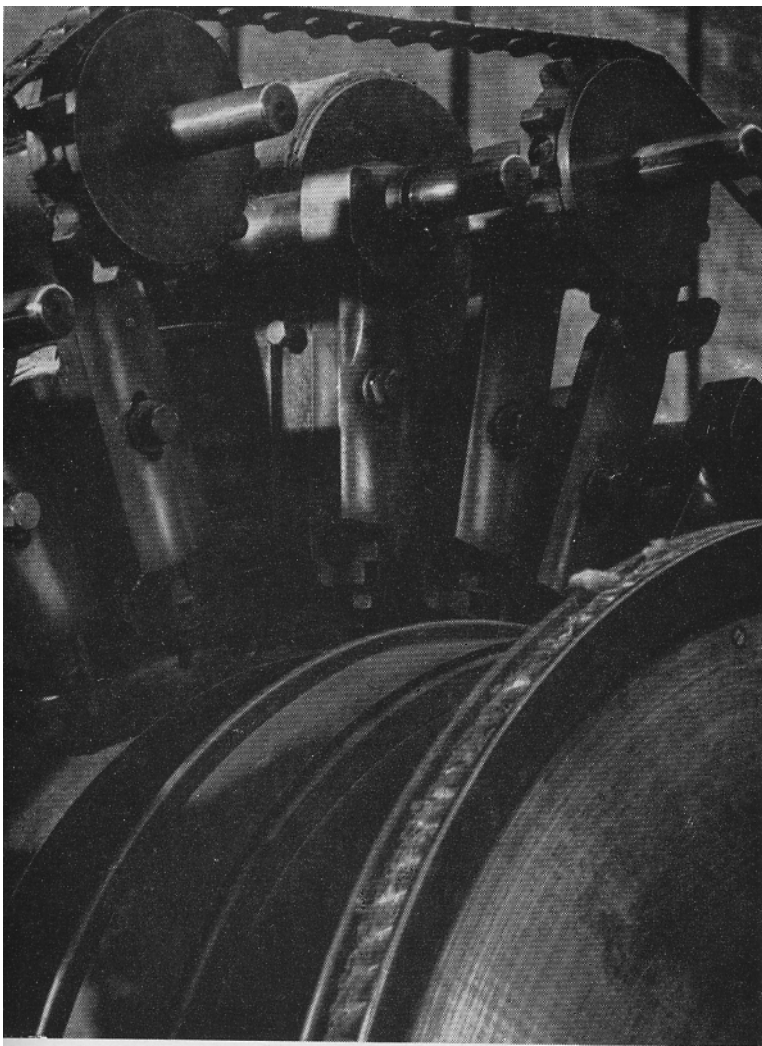

Carding engine showing the wool being carded as it passes over cylinders covered with fine metal teeth.

surface speed than the latter, and so bring about a partial straightening. Eventually, the fibres in the fallers are caught by a pair of delivery rollers which run at a still greater surface speed than the fallers, and so they in their turn pull the fibres through the faller pins and add to the straightening action. The wool, in a more parallel order, is then passed forward by the delivery rollers to form an endless sheet, or is coiled into a can. The fallers, having given up their material to the delivery rollers, drop into a lower screw and return to the feed rollers. After six separate gilling operations the wool fibres are sufficiently parallel for combing.

The preparing process is used only for the longer-stapled wools, which, if carded, would suffer undue fibre breakage. This in turn would lead to much shorter fibred tops, and since the longer-stapled wools are valued primarily because of their lustre it will be seen that the presence of short fibres would detract from their worth. The volume of material prepared contrasted with that carded is quite small, for whenever the fibre length permits one always cards, this process being cheaper in manpower and more productive.

WORSTED CARDING

The other and more common method of transforming the loose discontinuous locks of scoured, dry wool to an endless sliver is by the use of the carding machine.

In the worsted industry the wool is always carded in the white state. If it has to be dyed, this process is carried out after top-making, spinning, or weaving.

The aim in carding is (a) to disentangle the fibres one from the other, so that they exist as separate entities; (b) to mix the fibres together so that the different types which were blended together in the sorting process will be more intimately mixed fibre by fibre, which of course could not be achieved in the previous processes; and (c) to deliver these fibres from the machine in an endless sliver form. This is ensured by passing the web from the last roller of the machine through a narrow funnel so that the web, which was originally sixty inches wide, is condensed to some four or five inches, finally to be deposited into a can or wound on to a ball. At the same time the worsted card is also responsible for removing from the wool a large proportion of the vegetable matter associated with it.

REMOVING BURRS

Many types of vegetable matter may adhere to wool, but briefly they can be classified under three headings: burrs of the hard-head variety, those of the mestiza variety and the grasses. The former consist of seed cases and are either circular or elliptical in shape, and can be as large as $\frac{3}{8}$ inch in diameter. This class is relatively easy to remove. The wool is pushed in between the pins of one of the carding rollers, which are set so close together that the burrs ride on the top of the teeth and so can be flicked off by a high-speed flanged roller which rotates in close proximity to the card-covered roller. The mestiza burr is more difficult to remove. It consists of a long piece of vegetable matter wound to a compact ball, which during carding unfolds to resemble a centipede-like form about one or two inches in length. Being brittle, this impurity breaks into small pieces and attaches itself to the wool by reason of its ragged edges. The only way to remove this impurity and the grass-like varieties, is to crush them and then allow the dust to fall from the card or in the subsequent gilling process. To this end a Harmel crushing device is incorporated in the cards which have to process wools containing this form of impurity.

The presence of vegetable matter, which may amount to as much as twelve per cent of the weight of the wool, tends to restrict the production of the card, for it is clear that efficient de-burring can be accomplished only when the stream of material passing through the card is thinner than is normally the case.

It might be thought that steps should be taken in

rearing sheep to eliminate the bush on which the burrs grow and thus reduce the problem of removing them, but the farmers tell us that this bush is a source of sustenance to the sheep in times of drought and cannot, therefore, be destroyed. Failing this possibility of dealing with the problem, it might still be thought that the vegetable matter should be removed chemically by the carbonising process after scouring, which is often practised in the woollen industry. But again the disadvantages would outweigh the advantages. Briefly, the inclusion of the carbonising process, in which the scoured wool and vegetable matter are subjected to a bath of cold sulphuric acid and later heated to convert the cellulosic matter to a form of brittle hydrocellulose which can then be beaten from the wool, would so matt the fibres and lead to such excessive breakage in carding that the amount of noil made in combing would be too great to make it a practical proposition.

Furthermore it would be very difficult to introduce the carbonising process into the industry with its present structure. The top-makers are responsible for sorting, scouring, drying, carding, gilling, combing and making the tops which are then sold to the spinner, who draws and spins them. Very few spinners make a yarn from one type of top. It is more customary to blend together at the first drawing process tops from various combers, but the carbonising process materially alters the reaction of wool to chemical processes, especially dyeing, so it would therefore be necessary for the top-maker to supply the history of each top in order that the spinner might blend the carbonised and uncarbonised. And the complexity would still further be increased because the spinner sells his yarns to the weaver who again passes the cloth on to the dyer. Further, any differences in degree of carbonising would be reflected in variation of shade in the subsequent dyeing process; so it will be seen that the present mechanical means of removing vegetable matter gives rise to the least complications.

THE WORSTED CARD

The actual carding process is accomplished by a

machine similar to that shown in Figs. 1 and 2. The rollers are each sixty inches wide, but vary in diameter. Some idea of the relative sizes may be gained when it is realised that the two main cylinders of the machine, "N" and "a", are fifty inches in diameter, and the doffers "O" and "b" have a diameter of forty inches. Each roller is covered over its entire surface with card teeth. These are mounted in narrow strips of cotton cloth and wound in a spiral fashion round the rollers. It will be seen from Fig. 3 that the wire teeth are inclined; this assists in the various carding actions. In practice (Fig. 2) the card clothing is wound on the rollers so that the teeth incline with or against their direction of rotation, which depends on the action which the roller has to perform in the machine. The actual density or the number of teeth per square inch of roller surface increases from the first rollers in the machine to the last; thus the first lick, D, has 100 per square inch, the fourth lick, G, has 300, the first swift, N, 480 and the last doffer, b, 650.

The wool is fed to the card from a hopper which passes forward a uniform stream to a moving sheet, and this in turn presents it to the feed rollers A and B.

Briefly, the carding process is a repetition of three actions. First, a "working" action is brought about by the points of the one roller moving towards the points of another, (N and O) which disentangles the fibres. Second, a "stripping" action occurs when the points of one roller strip material from another by scraping the backs of the teeth of a second roller, (T and Q). And third, a "lifting" action takes place when the backs of the fancy teeth (rollers P and c) enter into the backs of the swift teeth (N and a) and raise the fibres to the surface of the latter rollers so that they can more easily be transferred from the swift to the doffers (O and b). Enlarged photographs of these actions have been shown in a previous article.¹

Reference to Fig. 2 will show that the rollers of the card rotate in various directions and incidentally at various speeds, as indicated by Table I. Furthermore the spacings between the rollers, which work in con-

1. See page 10.

FIG. 1 *Double worsted carding engine. The cans in the foreground collect the burrs after they have been removed by the burr beaters.*

(Courtesy: Platt Bros. (Sales) Ltd.)

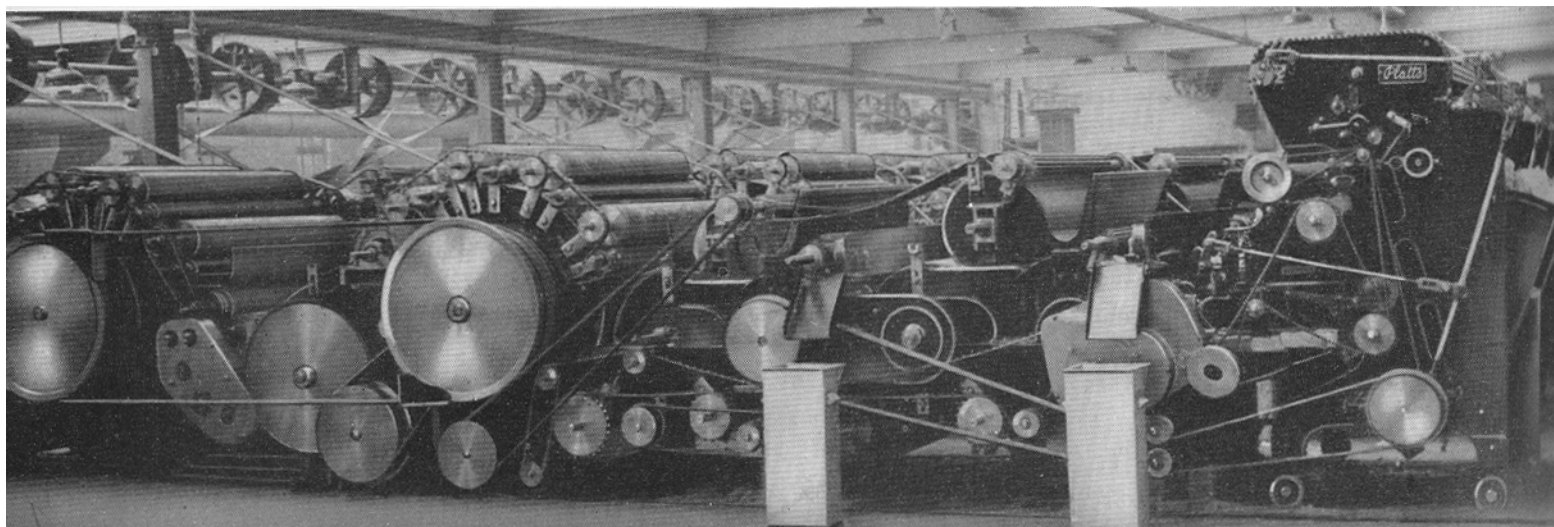

FIG. 2 Diagram of worsted card.
(Courtesy: Platt Bros. (Sales) Ltd.)

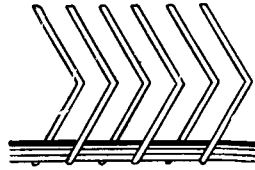
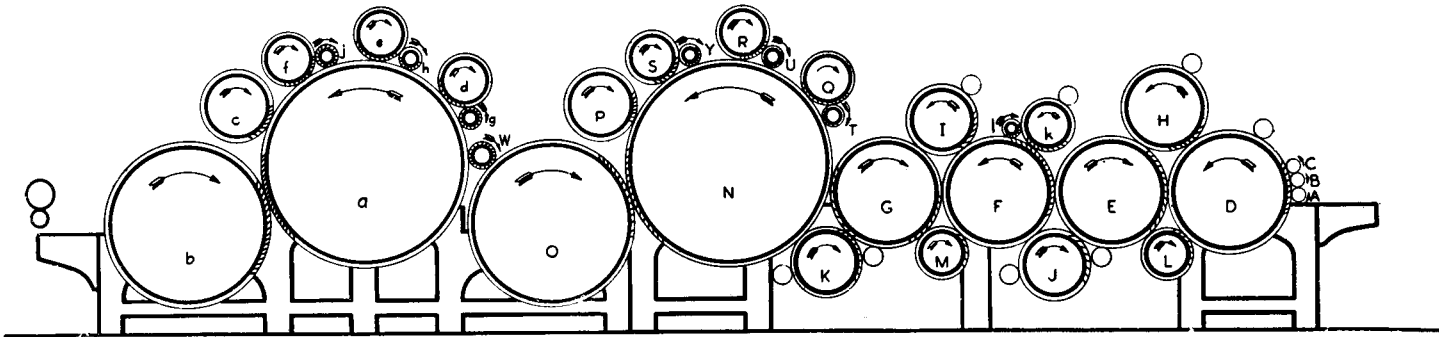

FIG. 3 Diagram showing arrangement of wire teeth.
(Courtesy: Longmans, Green & Co.)

junction with each other, gradually decrease from the first to the last rollers in the machine. Thus the wool is gradually disentangled as it passes through the machine, for it is first subjected to coarsely clothed rollers set at relatively open settings, and then, as the wool becomes more carded, the spacings between the rollers decrease and the pinning of the teeth increases. In this manner it is possible to reduce fibre breakage to a minimum, and yet disentangle the fibres to a fairly open state.

Finally the carded wool is removed from the last doffer, b, of the machine, by a swiftly oscillating comb

in a web which is gathered together, as shown in Fig. 4, to form a sliver. This is usually collected into cans, but it may be wound on to balls. The production per hour of a card varies again with the type of wool and the burr content, as the latter tends to reduce the output. Normally, merino wools can be carded at the rate of 40-50 lb. per hour, whilst the production in the case of crossbreds may be as high as 90 lb. per hour.

FIBRE BREAKAGE

The degree of fibre breakage varies considerably with the type of wool being carded and the amount of entanglement incurred in scouring and drying. The finer wool fibres are, of course, more easily broken than the crossbred varieties, and this tendency is further aggravated by the matting of the merino fibres in scouring. It is not easy to assess the degree of breakage which occurs in carding, because of sampling difficulties encountered in measuring the fibre length of the raw wool, but it is probable that, even under the best conditions, fifty per cent of the fibres entering the card are broken during their passage through the machine. This follows as a direct consequence of the entangled state of the fibres fed to the card and it is difficult to see how it can be avoided with our present technique of processing. It has a direct bearing on the relative weights of top and noil obtained from carded sliver, and since the noil content increases with the degree of breakage in carding this problem of fibre breakage is one of the carding engineer's chief worries.

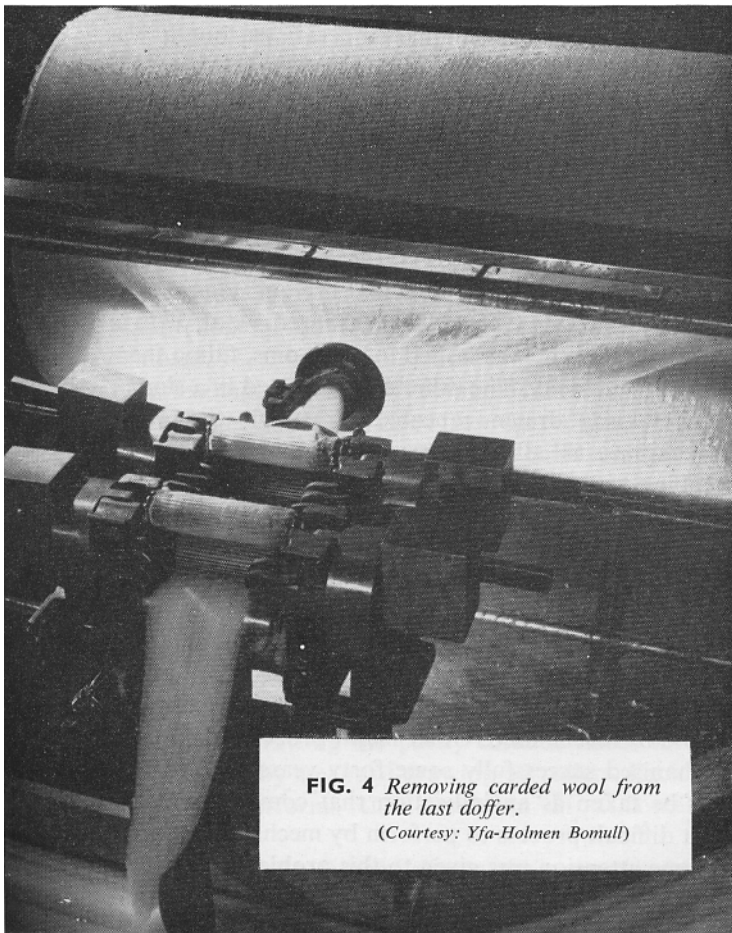

FIG. 4 Removing carded wool from the last doffer.
(Courtesy: Yfa-Holmen Bomull)

TABLE I

Ref. letter	Name of Roller	Diameter (inches)	Speed r.p.m.
A, B and C ..	Feed rollers ..	3	2
D	1st licker ..	30	12
G	4th " ..	26	120
N and a ..	Swifts ..	50	120
O, R and S ..	Workers ..	12	5
d, e and f ..	" ..	—	—
T, U and Y ..	Strippers ..	5	250
g, h and j ..	" ..	—	—
P and c ..	Fancies ..	16	450
O and b ..	Doffers ..	40	8