



Hand Combing.

WOOL COMBING

H. BEEVERS, F.T.I., C.G.I.A.,

*Head of Department of Textile Industries,
Keighley Technical College*

(Photos: Courtesy Wool (and Allied) Textile Employers' Council)

Mechanical Combing.

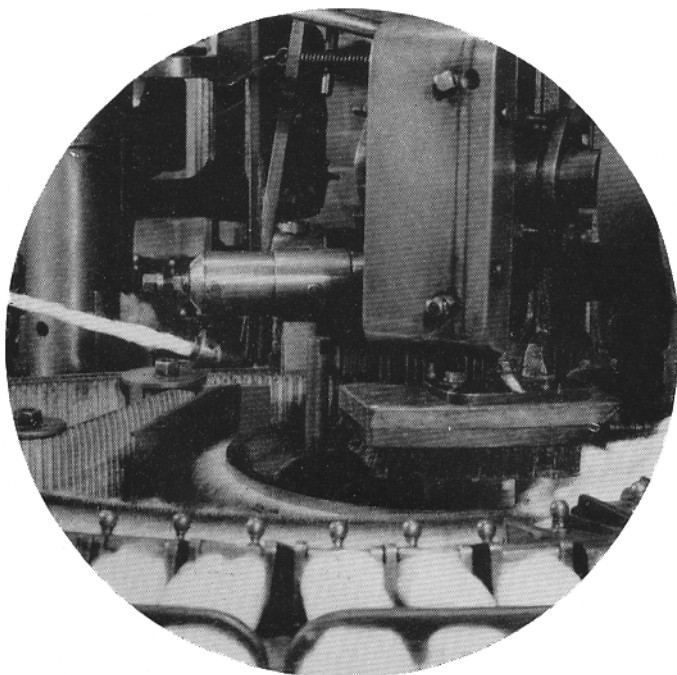

ALL wools designated for conversion into worsted fabrics must be combed through closely-set pins in their preliminary stages of manufacture in order to straighten out the fibres from a jumbled mass of scoured wool. In achieving this objective many fibres are broken and entangled. These must be separated as a by-product, known commercially as noil, which is used in the manufacture of felts, woollen yarns and woollen piece-goods. The long fibres which are retained are arranged parallel to each other in a continuous rope-like formation termed combed slivers. A number of these slivers put together for blending are gilled into tops.

The important feature of fibre alignment is the basic characteristic of worsted yarn manufacture. This parallel arrangement of the fibres is maintained during the drawing and spinning processes, thus producing smooth, clear, straight, strong and uniform yarns, capable of exhibiting clearness of design in the finished fabrics.

Moisture, heat and tension are essential in combing. These conditions facilitate the straightening of the fibres as they are drawn forcibly through hot pins.

HAND COMBING

In the early days of civilisation, hand spinning was done without any preliminary operations, but it was soon realised that if the wool were disentangled and the fibres made to lie parallel, spinning would be made easier. Even before the industrial era, it was a common practice to card the short and comb the long wools by using primitive tools.

In hand combing two large iron combs were used, each with two or three rows of long flexible pins. One comb was heated over a charcoal fire and temporarily fixed to a wooden post. Then scoured wool, with a touch of oil on it, was lashed into the pins, filling them almost to capacity. The other comb, heated in a similar manner, was drawn repeatedly through the dense fibrous mass till all the fibres were straightened. When combing was completed, the fringe of fibres projecting from the stationary comb was drawn off by hand in the form of a sliver. The short, broken, curly fibres remaining in the comb's pins were removed as noil.

EARLY MACHINES

Hand combing was universally practised until about 1840, and was the last operation in worsted manufacture to be mechanised. Other major processes had been mechanised successfully some forty years earlier. This may be taken as an indication that combing was the most difficult process to perform by mechanical means.

Some attention was given to this problem as early as 1790, when Dr. Edmund Cartwright, a clergyman and the inventor of the first power loom, made the first

attempt to comb wool by machinery. His efforts earned him the nickname "Bishop Blaize".¹ In his initial attempt he tried to imitate as closely as possible the hand process. He mounted a number of hand combs on a rotary drum, then, by means of a lashing device, the pins were charged with washed wool to be drawn off later by rollers. The machine was crudely designed and was driven by a horse. Cartwright's associates christened it "Big Ben". Unfortunately the noil left in the pins could not be removed during combing, so his invention did not succeed.

During the next twelve years, Cartwright constructed further models. His last machine, however, proved to be the most noteworthy because it contained five new ideas: a revolving circle with vertical pins, a steam-chest for heating the pins, a lashing motion for feeding the wool, strokers to turn the fibre ends towards the drawing-off rollers, and drawing-off rollers. All these features are used in combs today, but no machine uses them all. Although no modern combs bears Cartwright's name, it was his pioneer work that paved the way. From this point, the story of invention was crowded with achievement. Following Cartwright came Noble, Heilmann, Holden, Croft, Donisthorpe and others, who invented either new combs or modifications of the old models.

COMBING MACHINES

Three distinct types of combs have a wide commercial use in the worsted industry, and each is known by the name of its inventor – Noble, Lister and Heilmann. In each of these machines similar principles are employed, but different means have been adopted to put them into effect. In the combing procedure, five definite stages form the cycle of operations: feeding, initial combing, completion of combing, sliver formation, and noil removal.

In feeding, each type of comb has its own particular mechanism. The Noble is fed from specially made punch balls, the Lister is similar in construction to a gill box, while the Heilmann uses a reed motion.

Initial combing, which means combing out one end of the fibres, is performed by first creating a fringe, either by passing the slivers through rows of pins, or alternatively passing pins through the slivers. Each of the combs fulfils this requirement in a different way.

Completion of combing, as the name implies, is the combing of the remaining portion of the fringes. This is done by drawing the partly combed fibres through rows of pins by means of drawing-off rollers. Each type of comb performs this operation in a somewhat similar way.

When forming combed slivers, the successive fringes

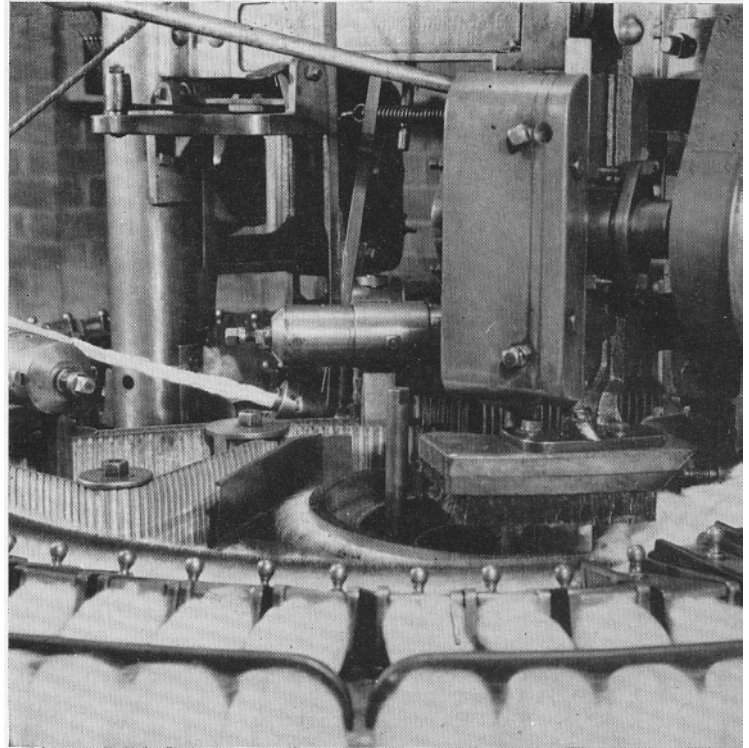

The Noble Comb. The long fibres are laid parallel and separated from the short fibres. The combed wool is shown coming off as a sliver.

The Lister Comb.

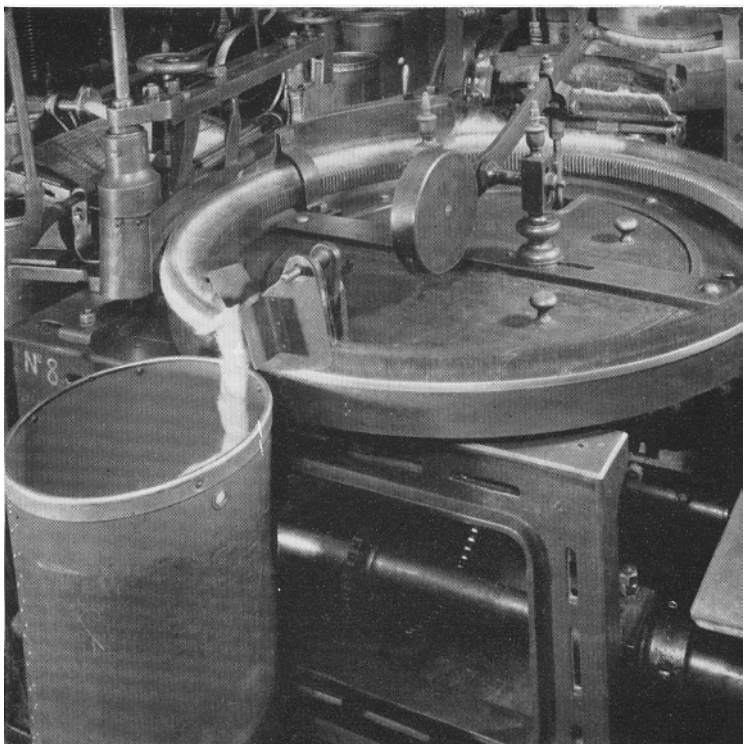

1. Bishop Blaize is the patron saint of wool combers.

Fig. 1 NOBLE'S COMB

(Section of Feed)

Showing the slivers passing through the guides, trap boxes, and under the stationary feed knife. As the trap boxes rise, a short length from each sliver is drawn through these boxes. Soon afterwards the slivers are lifted, by inclined plates, out of the large circle pins and re-laid across the pins of both large and small circles prior to dabbing.

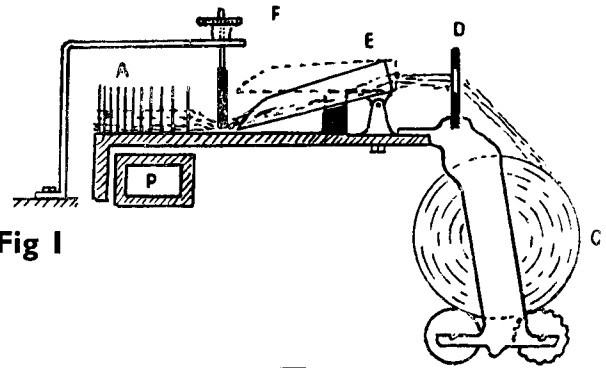

Fig 1

Fig. 2 PLAN OF NOBLE COMB

Showing the passage of the wool through the machine.

KEY TO PARTS OF COMB

- A — Large circle.
- B & B' — Small circles.
- C — Punch balls.
- D — Uncombed sliver guides.
- E — Trap boxes.
- F & F' — Feed knives.
- G & G' — Inclined plates.
- H & H' — Dabbing brushes.
- I & I' — Initial combing.
- J, J', J², J³ — Completed combing.
- K, K', K², K³ — Endless leather aprons.
- L — Revolving funnel.
- M — Combed sliver passing out of machine to coiler can. (Coiler can not shown.)
- N & N' — Noil knives, set between the rows of pins. (On small circles only.)
- O & O' — Noil cans.
- P — Steam chest.

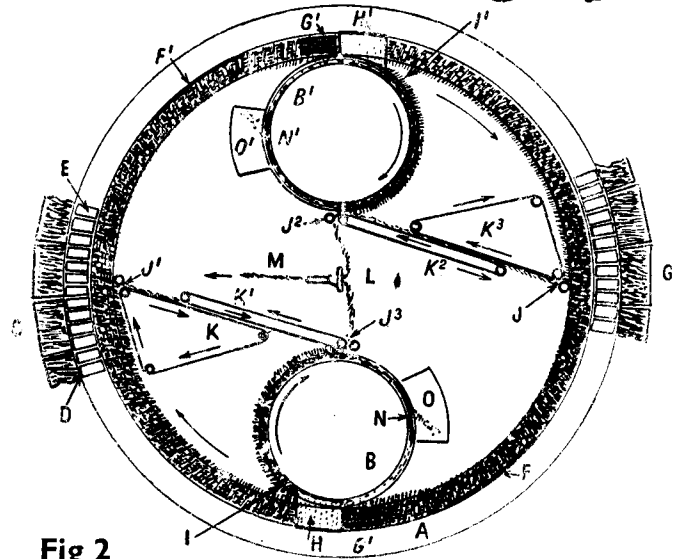

Fig 2

Fig. 3 PLAN VIEW OF LISTER'S COMB

Showing the transfer of the "initial" combed wool from the feed head to the circle, dabbing, and "completion" of combing by the drawing-off rollers.

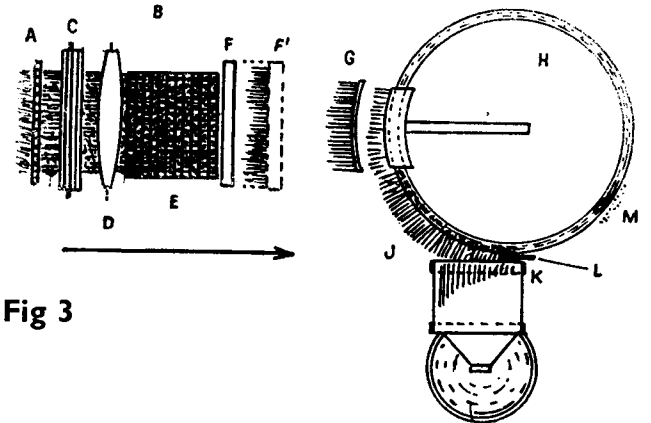

Fig 3

Fig. 4. SIDE ELEVATION OF LISTER'S COMB

To illustrate further the above procedure.

KEY TO PARTS OF COMB

- A — Uncombed sliver guides.
- B — Feed head.
- C — Feed rollers.
- D — Barrel shaped roller.
- E — Curved fallers.
- F & F' — Swing "nip" (two positions).
- F² — Fulcrum of swing nip framework.
- G, G', G² — "Carrier" comb (different positions).
- H — Comb circle.
- I — Dabbing brush.
- J — Successive wool fringes.
- K — Horizontal drawing-off rollers.
- L — "Cut-off" knife.
- M — Noil removal.

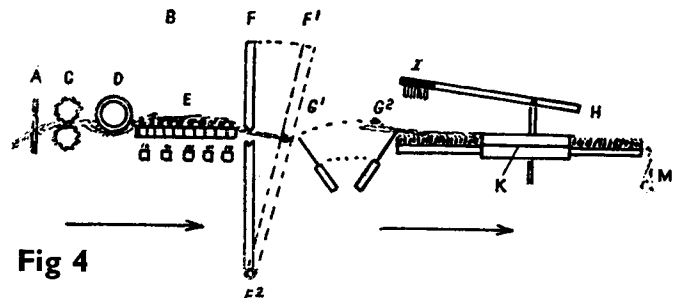

Fig 4

are placed together in an ingenious way, causing each one to overlap its predecessor. Some assistance, however, is obtained by endless leather aprons, operating round the drawing-off and ancillary rollers. These support the steady flow, promoting some regularity and strength before the united combed sliver passes out of the machine into the coiler can.

Noil removal is accomplished in Noble and Lister combs by drawing the long fibres away from the short ones. The Heilmann reverses this order by removing the short from the long fibres while the latter are held in a nip. In all instances, the noil is deposited in the pinned regions after combing has been completed, to be removed continuously by knives and brushes.

The choice of machine largely depends on the class or type of wool to be combed, as long or short fibre lengths require different treatment. Other considerations include style of top, ratio of top to noil, production of machine and cost of combing.

The main features may be summarised as follows. The Noble or Circular comb is the most popular type in the industry, because by interchanging the pinned circles it can be utilised to suit a wide range of qualities. This comb produces more than any other type, is automatic in action and requires little attention with the exception of feeding and removal of combed sliver cans.

The Lister, often referred to as the "nip" comb, has a good reputation for producing very smooth lustrous tops of excellent spinning properties. It is used exclusively for long wools and hairs.

The Heilmann or "French" comb deals successfully with short, tender and burry wools. A high ratio of top to noil is achieved, as it straightens out many fibres which would be rejected as noil on other machines. This type of comb is used particularly for the production of dry combed tops for processing on Continental drawing machinery. This comb occupies little floor space, but its productive capacity is comparatively low.

NOBLE COMB

James Noble of Leeds finally patented his comb in 1854 after some years of collaboration with Donisthorpe of Leicester. Working together, these two inventors had brought the machine to a state of perfection in principle. Since then, however, textile machine makers have modified the original construction to meet present-day needs for high-speed production.

The essential features of the Noble Comb (Figs. 1 and 2) consist primarily of three circles – two small circles B and B¹ of 16 inches diameter fitted inside a large circle A of approximately 43 inches diameter. All are geared to rotate in a clockwise direction. Each circle is covered with several rows of vertically-set pins, suitably mounted in brass foundations. On the large circle the pins graduate in fineness of setting towards the inner rows. In the case

of the small circles the position is reversed, the finer pins being set towards the outer rows. This arrangement is for the convenience of drawing off the long fibres at specific points.

The slivers are fed into the comb from eighteen punch balls C, previously prepared on an ancillary machine which assembles four slivers side by side under tension, for easy accommodation in the comb creel. The eighteen balls, each with four slivers, are required to fill the creel, making a total of seventy-two slivers which completely surround the large comb circle. The slivers arranged in this way are intermittently fed through guides D, trap boxes E, and pins forming a continuous fringe projecting inside the large circle. At two points, diametrically opposite, the slivers pass under feed knives F and F¹, to take in further supplies of sliver. Afterwards, the material is lifted from the large circle pins by inclined plates G and G¹, causing the extra length to spread over the pins of both large and small circles at the points of contact.

The dabbing brushes H and H¹, operating at about 1,000 dabs per minute, press the wool firmly into the pins. As the circles diverge by reason of their size and rotation, initial combing I and I¹ is achieved when two newly-formed fringes appear, one on the inside of the large circle and the other projecting outwards from the small circle, both fringes having passed through the other circle pins. The ends of these fibres still retained in the circle pins remain uncombed.

Completion of combing J, J¹, J² and J³ is carried out a few seconds later, as the circles rotate conveying their respective fringes towards vertical drawing-off rollers, where the long fibres are drawn continuously through the pins at four points, two at the large circle and one at each of the small circles. Endless leather drawing-off aprons K, K¹, K² and K³, running between the rollers, transmit the four slivers to a central funnel L, where they unite to pass out of the machine into a coiler can. Short fibres, "neps"² and vegetable matter remaining in the small circles are lifted out by stationary noil knives N and N¹ set between the rows of pins, and deposited into noil cans O and O¹ placed alongside.

LISTER "NIP" COMB

In 1849 Samuel Cunliffe Lister of Manningham, Bradford, patented his comb (Figs. 3 and 4) for long-fibred wool which had in most cases passed through a preparing set.

A number of slivers A, uniformly arranged in suitable guides, pass through the feed head B. This mechanism resembles an ordinary gill box, except that it contains curved fallers E carrying three rows of finely-set pins and that the front rollers are omitted. A barrel-shaped roller D receives the slivers from the fluted

2. Small knots of tangled fibres.

feed rollers C and guides them into the faller pins. A swing nip frame F and F¹, mounted in place of the front rollers, is constructed with two curved jaws which close upon each projecting tuft, after each faller has descended to the lower screws. This frame, which has its fulcrum F² at the lower end, swings away, drawing a broad fringe of straightened fibres, thus carrying out initial combing. As it reaches the extreme end of the traverse, the nip jaws open, permitting the long, slender pins of the carrier comb G, G¹ and G² to pierce the fringe. The duty of this carrier comb is to transfer the partly combed wool to the comb circle H. In doing so, it moves in an elliptical orbit, carefully placing the fringe over the pins, then steadily withdraws to return for further supplies. Accuracy of movement is essential for good combing, as faulty strokes at either end may cause defective work.

The dabbing brush I, operating in conjunction with the carrier comb, makes one dab for each fringe deposited. The comb circle, a little larger than in the Noble, revolves slowly at one revolution per minute, allowing each fringe to overlap its predecessor. Eventually a continuous fringe, projecting outwards, is formed. This meets the horizontal drawing-off rollers K, placed at a tangent to the circle, and completes the combing by withdrawing the fibres through the pins. The position of these rollers causes the longest fibres to be drawn away first, graduating by reduction to shorter fibre lengths across the roller face. This produces a "hen-wing" sliver. Before this sliver passes from the machine it is rolled with the aid of guide bars and air blasts in such an ingenious way that the shorter fibres occupy the core position with the longest fibres outside. The noil left behind in the circle pins is removed in a similar way to that of the Noble comb.

The ratio of top to noil is governed by the amount of throw-over of the fringe by the carrier comb and the position of a cut-off knife L situated between the drawing-off rollers and comb circle. Forward setting of the knife causes a greater proportion of longer fibres to be rejected as noil M, whereas a backward setting reduces the fibre length for noilage but provides an inferior top.

HEILMANN COMB

Although Heilmann of Alsace invented his comb for use in the cotton industry, it was soon modified for combing short wools which could not be treated satisfactorily on the English combing machines.

Twenty-four or thirty-two carded slivers are normally fed through a pair of fluted rollers into the reed motion. This contrivance is composed of three brass plates, working together in a four-fold movement. The lower and middle plates, grooved and slotted respectively, support the slivers as a series of pins projecting downwards from the upper plate pass through

the slots to penetrate the slivers and move them forward into the nipper jaws. As the lower and middle plates move back together to their former position, the pin-plate is withdrawn to continue the cycle. The nipper jaws hold the sliver ends in the form of a fringe, as it is initially combed by a revolving comb cylinder, whose eighteen rows of graduated pins, fixed at a tangent to an arc of the cylinder, pass through to clear away the short fibres not held in the nippers. When the last row of pins has passed through, the nipper jaws open to release the partly combed fibres, while a pair of horizontal, spirally-fluted drawing-off rollers move forward to seize the fringe. Precisely at the same moment, a finely-pinned intersector comb descends to pierce the fringe. This ensures the complete clearance of any



The Heilmann Comb.

remaining short entangled fibres and burrs during drawing off.

It will be observed that combing is achieved by treating successive fringes or tufts of fibres which are detached in rapid succession from the slivers fed in. These tufts are reunited later by an ingenious action of the drawing-off roller mechanism. A reciprocating motion causes the rollers to reverse their direction of rotary movement as they swing forward into the drawing-off position, in such a manner that each tuft overlaps its predecessor by about two-thirds of the fibre length and forms a continuous combed sliver. The sliver is conveyed by an endless leather apron to a brass funnel leading to a pair of synchronised calender rollers mounted above the coiler can.

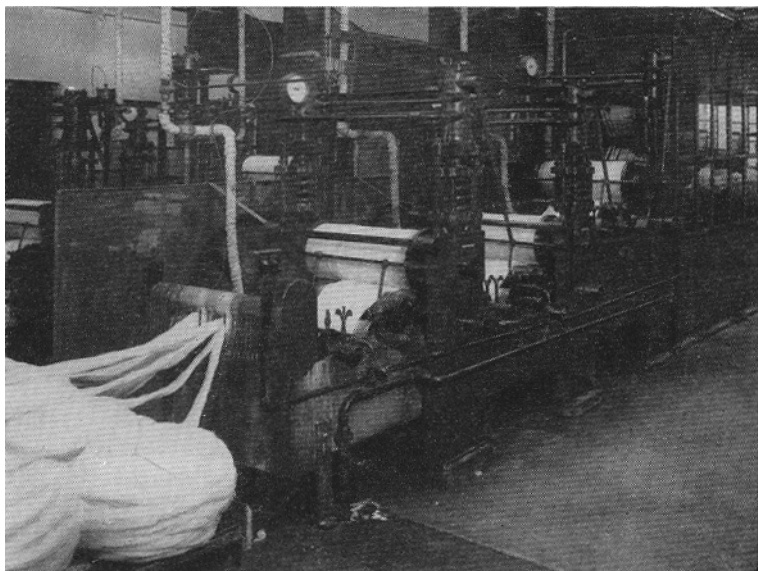

Backwashing, a secondary washing of the wool in sliver form to remove earthy substances left in the staples after the first cleansing.

The noil left behind in the comb cylinder pins is removed by a brush roller, whose long bristles penetrate deeply into the pinned sector and strip off the noil which falls into a box placed under the machine. Some assistance is given to the brush by a closely-set "garnett" wire covered roller and an oscillating picking knife.

Noil tearage can be altered within certain limits by adjusting the length of feed per cycle and the distance of the drawing-off rollers from the nipper jaws. An increased feed and/or increased setting distance of rollers from nippers will increase the amount of noil removed and vice versa.

Top finishing.

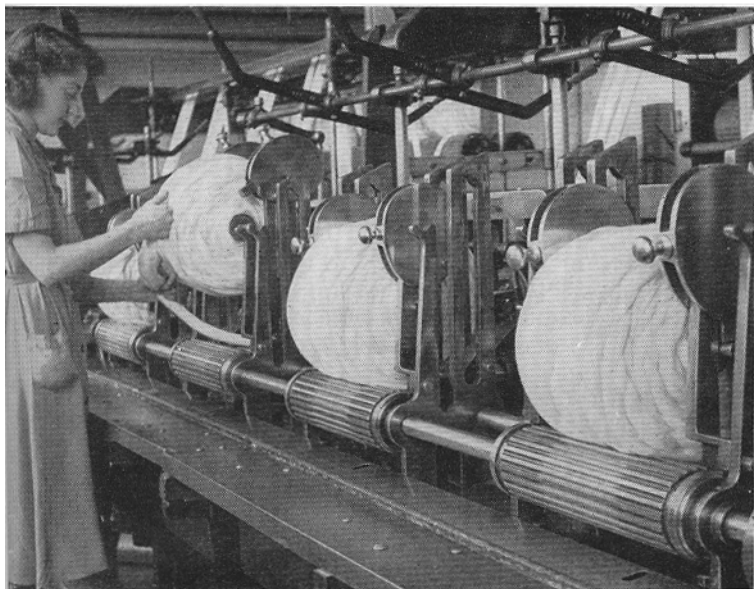

TOP FINISHING

The conversion of combed slivers into tops generally consists of two gilling operations performed by machines known as the Gill Finisher and the Gill Baller. The function of these machines is to blend the fibres thoroughly, to deliver a uniform weight per unit length of sliver, to add "condition" (moisture) according to standard trade allowances, and to deliver the material in ball form.

From all types of combs the slivers are irregular as a result of periodic fibre groupings peculiar to the methods of drawing off. If the best results are to be obtained in later drawing and spinning operations, it is imperative that fibres of various lengths should be blended evenly together throughout the resultant top slivers. This redistribution of fibres is accomplished by using adequate doublings together with suitable drafts on both machines.

Moisture is added to raise the regain of the wool to conform to trade standards for buying and selling. It is applied on the finisher box by passing the slivers over a conditioning roller revolving in a water trough. Adjustments to the roller speeds can be effected by change wheels to meet all requirements.

The final top sliver is assembled in ball form at the last box and made into a convenient size for easy handling. Two types of tops are built, ordinary and bumped. The former are firmly wound on a central spindle which is afterwards withdrawn and mounted on a pair of oscillating calender rollers. Tops made by this method are neat and compact, and are largely used for merino and fine, medium and strong crossbred wools. Bumped tops are first assembled in a can on the box, being coiled round a vertical spindle fixed to a detachable wooden base. When sufficient length has been run into the can, the spindle with the top sliver is lifted out, put into a small press and bumped. It is then secured with glazed string and the spindle is withdrawn. This method is restricted to slippery fibres such as long lustre wools and hairs.

The completed tops are now wrapped with soft paper and bagged ready for despatch to the worsted spinner for conversion into warp, weft or hosiery yarn. He may choose to process them as white to be yarn- or piece-dyed later, or he may arrange to have them dyed in order to blend several colours together to provide speciality-coloured mixture yarns according to manufacturers' requirements.



THE MANUFACTURE OF WORSTED YARNS

PART I — FROM COMBED TOP TO FINAL ROVING

H. BEEVERS, F.T.I., C.G.I.A.,

Head of Department of Textile Industries, Keighley Technical College

THE primary object in wool combing is to convert raw wools into worsted top slivers, after they have been scoured and carded, so that the basic materials shall be in a suitable state for manipulation into worsted yarns. As described in a previous article,* these top slivers resemble in appearance long, thick, untwisted ropes of fibres. However, a closer examination will reveal that the fibres are assembled in a parallel formation throughout the entire bulk. This predominant feature of fibre alignment must be retained throughout the subsequent processes necessary to create the fundamental structure of worsted yarns. In the later roller-drafting actions, the fibres move forward progressively until the slivers become much thinner, when a final twist is given by a revolving spindle to bind them together firmly into yarn.

The top sliver may contain approximately 35,000 fibres in each cross-sectional area, compared with, say, fifty fibres within a similar dimension of an average worsted yarn. It will be necessary, therefore, to achieve an effective sliver reduction of 500 to 1. If this major reduction were attempted at one stage only, on normal existing spinning machinery, marked irregularities would occur along the yarn. This is due to the inadequate means available of controlling the shorter fibres, which tend to move forward in groups during attenuation. In order to avoid this grouping of short fibres, the top

*"Wool Combing": See page 22.

slivers are gradually drawn out through a series of machines, commonly termed a "drawing set", to produce rovings† of a suitable weight per unit length, for spinning into the appropriate fineness of yarn. Although several systems of drawing and spinning machines are employed in the worsted industry, any one system may be selected by reason of its suitability for dealing with different classes of wools to produce specified types of yarns.

It will therefore readily be understood that from a wide variety of tops, each differing in fineness of fibres, length, strength, colour and handle, an unlimited range of yarns can be spun. The choice of drawing and spinning systems may seem to amplify the "leanness" or "loftiness" properties of the fibres, contained in the original tops. In many cases, however, the spun yarns may be utilised as singles, or further multiplied by twisting two or more together to achieve greater strength, balance and effect in the ultimate woven or knitted fabrics.

DRAWING

The popular systems of worsted drawing in commercial use throughout the world since the early part of this century and even in use today are generally known as Open, Cone and Porcupine. The first two systems are

†Final product of the drawing process; a strand of wool of the desired thickness for spinning into yarn.

also referred to collectively as Bradford systems while the "Porcupine" is usually known as Continental. These names have probably arisen from the respective places where early development and centralization were first established.

During the past 15 years new drawing sets have been designed, incorporating autoleveller mechanisms, with fewer operations involving less floorspace and power, and reducing the number of operatives required to manipulate the machines. These are known as the New Bradford and New Continental systems.

In these sets, the number of operations may vary from five to eleven, depending on the class of wool to be processed and the degree of roving thickness desired for spinning. Long fibred wools can be drafted to a greater extent than short wools, but thick rovings do not require drawing out as much as thin rovings.

In all cases drafting is accomplished by passing the slivers through at least two pairs of rollers. The front pair revolve at a relatively greater linear speed than the back pair, perhaps at ratios of 4 to 1 for short wools, or even 16 to 1 when the longest wool types are processed. This produces a decisive reduction in sliver thickness at each stage. Different mechanical devices, such as fallers, carriers or porcupines, are assembled within the drafting zones peculiar to the drawing set, to regulate the flow of fibres into the faster-moving rollers, and these mechanisms will be discussed more fully later.

Every drafting operation is accompanied by doublings which means that a number of slivers are fed together to produce uniformity in the resultant slivers. This ensures good blending of the fibres and also reduces any potential variations likely to occur from one roving to another on the last operation before spinning. For reasons of economy doublings are used to a greater extent in the early stages and are gradually reduced in number towards the roving stage.

As the materials progress from one operation to the next, the heads,* rollers, spindles and bobbins steadily increase in number and diminish in size to accommodate the different sliver weights at each stage. For the sake of reference and convenience in the mills, each operation in a normal sequence is given a particular name. Many of these examples are quoted in the table on page 33, together with typical layouts of doublings, drafts, sliver weights and total numbers of heads or spindles on the respective drawing sets.

OPEN DRAWING

This system is reminiscent of Arkwright's early work and is still perhaps the most popular method of drawing in use, because it is capable of dealing with a wide range of tops. These include British wools, Dominion strong, medium and fine crossbred, long Merino types and

*Containers or spindles from which slivers are drawn.



Sets of combed slivers from eight heads or cans are being fed together into each gill box.



Doubling, an operation which here consists of plying together three ends of spun yarn from three bobbins or cops on to one spindle.

First can gill box in open drawing.

(Courtesy: Wool (and Allied) Textile Employers' Council)

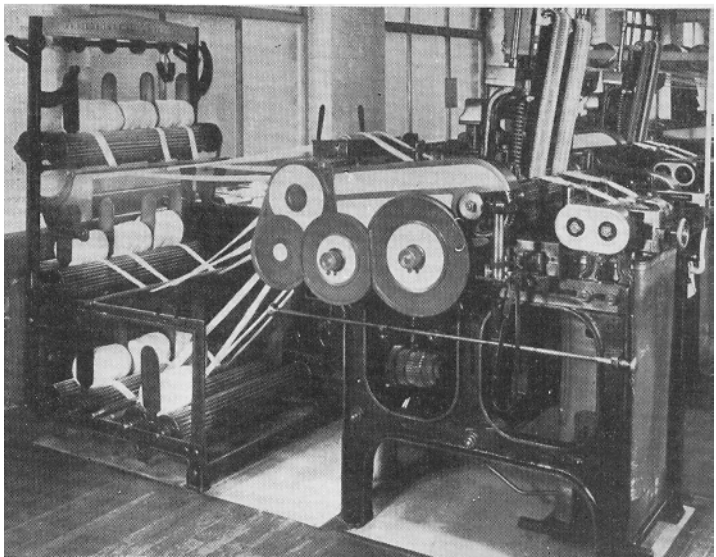

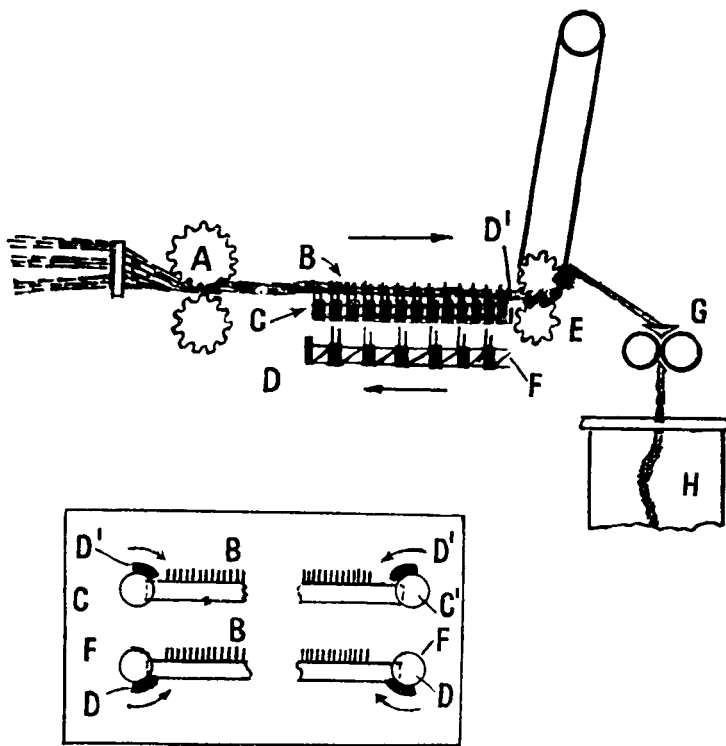

FIG. 1 OPEN DRAWING CAN GILL BOX.

An endless leather apron passes between the front rollers to give an "elastic nip" and thereby prevent damage to the wool during drafting.

(Inset) Showing the action of cams (fixed to the faller screws) causing the transfer of fallers into the lower and upper screws respectively.

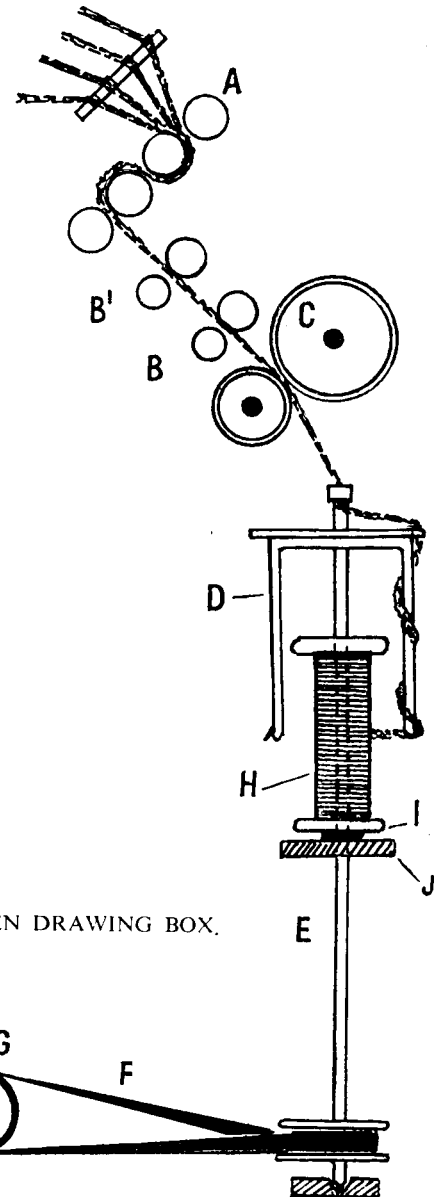

FIG. 2 OPEN DRAWING BOX.

hairs, which are converted into coatings, serges, dress goods, lustre cloths and carpets. The wools so treated should be of reasonable length, sound in fibre and processed with care, otherwise irregularities may result because of the mechanical strains imposed upon them during their passage through the machines.

The sequence of machines may be divided into two sections, (i) gill boxes and (ii) drawing and roving boxes. In the early gilling operations, the primary objective is to open out the slivers to facilitate easy fibre movement in the subsequent boxes, and also attenuate these slivers to a more uniform state.

At the first gill box, the tops are placed on end to rest on rotating creel rollers behind the machine, for convenience of unwinding before entering the back-feed rollers of the drafting zone. As they pass forward (Fig.

1) the fibres are held momentarily by a series of pinned-steel bars B, termed fallers, which are actuated by propelling screws C and cams D. These fallers rise in quick succession to pierce the slivers and move them towards the front delivery rollers E, where the fibres are drawn through the pins. At this point, each faller is depressed in turn, out of contact with the wool, by cams D¹, and returns by way of the lower screws F towards the back rollers A, and so continues its cyclic motion.

From the front rollers, the gilled slivers emerge in a lofty open condition and are then conducted through calender rollers G, into cans H for transfer to the spindle gill box. In this second operation, the wool slivers receive a similar drafting treatment, then pass through apertures in revolving flyers which impart a little twist to the slivers before they are wound on to large bobbins.

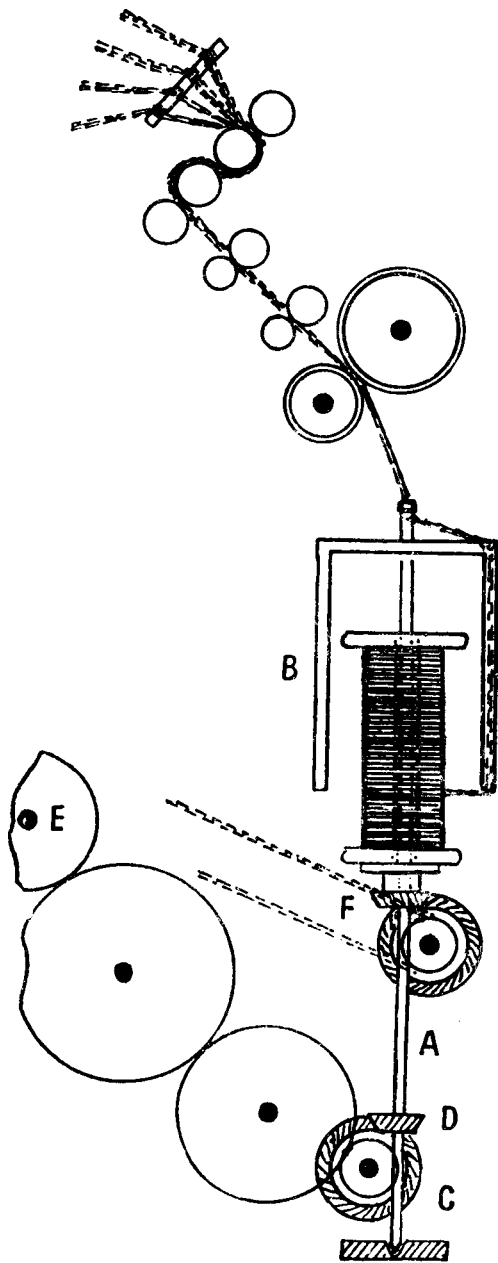

FIG. 3 CONE DRAWING BOX.

In the succeeding drawing boxes (Fig. 2), the technique of controlling the fibre movement during drafting is changed, because it is practically impossible to attenuate twisted slivers through dense masses of pins. So an alternative method is practised which utilises two lines of carrier rollers, B and B¹, instead of pinned fallers. The function of these carriers is to support the "slubbings" (twisted slivers) and retain the coherent twist until it reaches a crucial point near the front rollers C, where it is released to permit the shorter fibres to move forward in regular sequence. This principle of drafting is generally referred to as "drafting against twist".

To assist the uniform flow of the long fibres and also to avoid fibre breakage, the back tier of rollers A must be adjusted to the front pair at a distance exceeding the maximum fibre length in the bulk lot. On leaving the

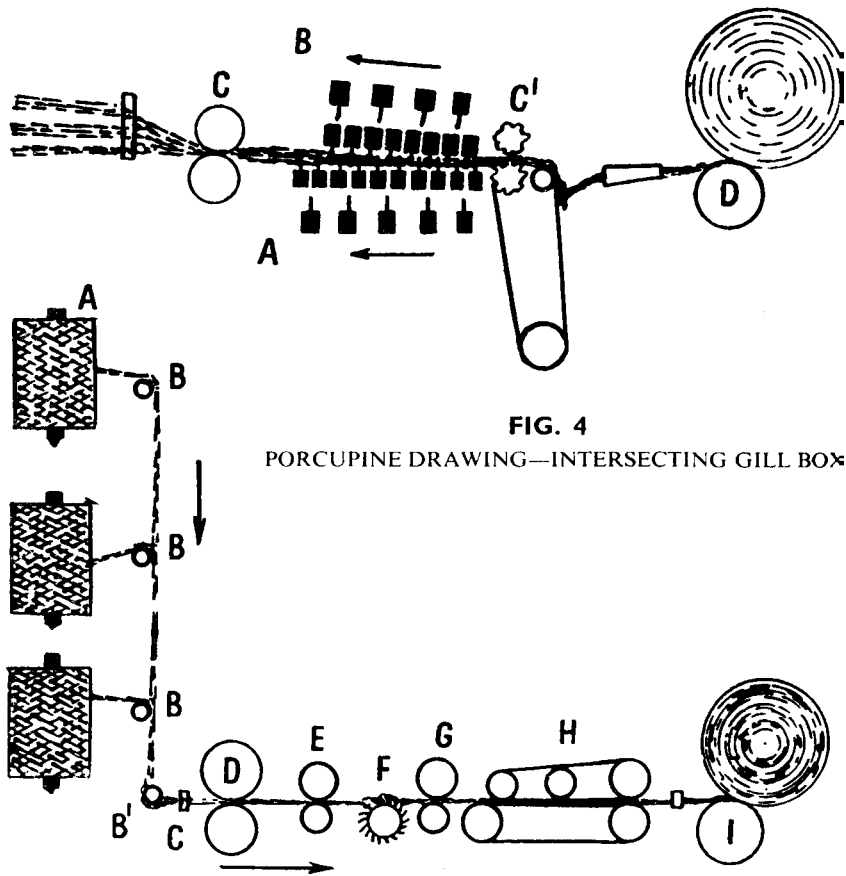

FIG. 4

PORCUPINE DRAWING—INTERSECTING GILL BOX

FIG. 5 PORCUPINE DRAWING BOX.

front rollers, the various doublings fed together emerge as one slubbing and pass to bobbins which insert a higher number of twists at each successive operation.

It may be of interest to note that each flyer D is loosely fitted to spindle E and is driven by means of a belt F from a rotary cylinder G. Such flyers perform the dual functions of imparting twist to the slubbings and winding the latter on to the bobbins. For each revolution of the flyer, one turn or twist is inserted and by its superior speed over that of the bobbin H, which fits loosely on the spindle, the slubbing is deposited on the bobbin, while the latter is being retarded by a felt washer I placed beneath it. A lifter plate J supports and traverses the bobbin inside the flyer to effect an even distribution.

The structure of the roving resulting from this system of drawing may be described as fairly soft, round, clear

and straight fibred, containing a fairly firm degree of twist for spinning into "lean" yarns to exhibit clearness of design in the ultimate fabrics.

CONE DRAWING

The introduction of cone drawing into the worsted industry in 1905 was primarily intended to deal with weaker types of wool incapable of withstanding the mechanical strains met with in open drawing. But today it is highly recommended for typical merinos and fine crossbred wools which are used for dress goods, fine coatings and high-class hosiery. This system may be described briefly as a modification of open drawing, as the layout of machines and the methods of drafting are almost identical. The major difference lies in the fact that positive drives to spindles, bobbin and lifter have superseded the negative frictional drives of the older system. This allows accurate changes to be made in relieving the strains imposed on the slubbings during their forward passage to the bobbins.

As illustrated in Fig. 3, the spindles A and flyers B are together rotated by gear wheels C and skew bevels D from the central shaft E. These ensure constant speeds and uniform twists in the slubbings. But the complexity of the bobbin drive mechanisms (partly shown at F) is to provide a series of retrogressive bobbin speeds throughout the full period of filling, in order to maintain a proper linear relationship between the front roller delivery and the increasing bobbin circumferences for each additional layer of slubbing.

This variable drive is obtained by a pair of cones (from which this form of drawing derives its name) working in conjunction with a differential gear. In the first place, constant rotation is given to the driving bevel in the differential motion which transmits its velocity to the bobbin wheel, through two intermediate bevels accommodated inside the crown wheel. An independent variable speed drive from the cones is geared to the periphery of this crown wheel, to rotate the intermediate bevels round the axis of the initial driving bevel and so produce an epicyclic effect which in turn is also transmitted to the bobbin wheel. Thus for every movement of the belt across the cones, the crown wheel will diminish in speed and consequently reduce the bobbin speeds pro rata at each traverse of the lifter plate.

In comparison with open drawing the main advantages gained are that large orders can be handled conveniently, as larger bobbins can be utilised, which enables the process to run for longer periods with fewer doffings, less waste of material and thus with greater efficiency. Less twist is permissible in the slubbings, which consequently increases the production of each drawing set, and the resultant rovings are similar in

character to those produced by open drawing, but are much softer and fairly lofty in appearance.

PORCUPINE DRAWING

In the years between 1846 and 1855, European continental wool workers established a system of drawing to produce rovings without twist, with the intention of converting very short types, normally classed as clothing wools, into worsted yarns, which had been impossible on the open system. These types of wool include lamb, short varieties of merinos, fine crossbreds and Downs, tender, heavily-conditioned wools and long noils. Since those earlier years, however, this system has had a universal application for all classes of wools up to seven inches in fibre length, as the method of treatment preserves the natural crimp fibre features so desirable in soft dress goods and hosiery garments.

Although top sliver reduction is accomplished by roller drafting and the regularity of product is achieved by incorporating doublings, fibre control within the drafting zones is carried out at every operation with the aid of pin treatment. Therefore, spindles, flyers and bobbins are eliminated entirely. Consolidation of the slivers is obtained by rubbing leathers. These leathers have a rotary and lateral motion which promotes some fibre cohesion and imparts strength to the slivers, which are wound on to wood barrels for easy transfer to the next operation.

In this drawing set the layout of machines may be divided into two sections, similar to the Bradford systems, namely gill boxes and drawing boxes, for in this case the gill boxes are constructed on the multi-head design, with intersecting fallers, as shown in Fig. 4. These consist of two sets of fallers, A in the lower plane and B mounted above with inverted pins. As the fallers operate, both sets of pins intersect as the slivers pass between them. It is claimed that with this greater uniformity of pin distribution, more effective control of the shorter fibres is obtained. In addition, small diameter rollers C and C¹ are fitted and calender rollers D are introduced to wind the drafted slivers on to balls E.

From this point, all the drawing boxes are alike in principle and construction. But, as shown in the Table on page 33, they steadily increase in number of heads and become shorter in pitch as they approach the final stage. As shown in Fig. 5, the balls of sliver being fed into the machine are arranged on vertical skewers in the creel A, to pass over the revolving creel rollers B and B¹, through the guides C to the back rollers D. In the drafting zone the carrier rollers E support the slivers as they pass through the porcupine F to front rollers G. The porcupine rollers are studded with rows of fine pins, set tangentially to the periphery. As these pins

rise and penetrate the slivers they move forward a short distance while the fibres are passing through, finally leaving the slivers with their pins in a vertical position. The ensuing slivers, much reduced in thickness, travel through the rubbing leathers H to be wound on to balls by the calender rollers I.

Thus it will be appreciated that in the absence of repeated fibre strains, the resultant rovings possess a fairly loose open structure but are in every sense truly worsted.

NEW BRADFORD DRAWING

This shortened system of drawing was evolved around 1950 and consists only of three or four operations. This new layout has been made possible by (i) the incorporation of the Raper Autolevelling device in the first two operations to improve the uniformity of the outgoing slivers and so enables the number of doublings to be reduced as compared with the older drawing systems and (ii) the production of heavier rovings suitable for high-draft and super-draft spinning frames.

The first operation is known as the Raper Autoleveller gill box which is similar in principle and construction to that used in Bradford drawing with a single head. This gill box is capable of higher faller speeds of 1,200 drops per minute and is fitted with an Autoleveller device. Twelve to eighteen top slivers are fed to the gill box in the normal way from a power creel to the measuring rollers on the Autoleveller unit. These rollers automatically measure the degree of irregularity of the composite ingoing slivers, a time-delaying mechanism and a pair of cone pulleys alter the speed of the back rollers and fallers to adjust the draft to compensate for the irregularities and ensure a constant weight per unit length of sliver being delivered by the front rollers into a delivery can.

A variation of 15 per cent in the sliver may be encountered – beyond this variation the machine is stopped and a signal light is illuminated to draw the attention of the operative.

The second operation is an Autoleveller draw box fitted with pressure drafting units. A single end sliver is fed to each Autoleveller unit of small design, with an input variation of 25 per cent. The sliver passes through the measuring back rollers into the pressure drafter unit fitted between the back and front rollers in place of the front carrier roller. The pressure drafter consists of a metal box with an adjustable lid to apply pressure to the sliver which is controlled by three micro-setting dials. By this means, the short “floating” fibres are under satisfactory control and drafting is carried out effectively by the front rollers. From this point the draft slivers pass to positively driven flyer spindles and bobbins to insert the necessary uniform soft twist for drafting at the next operation.

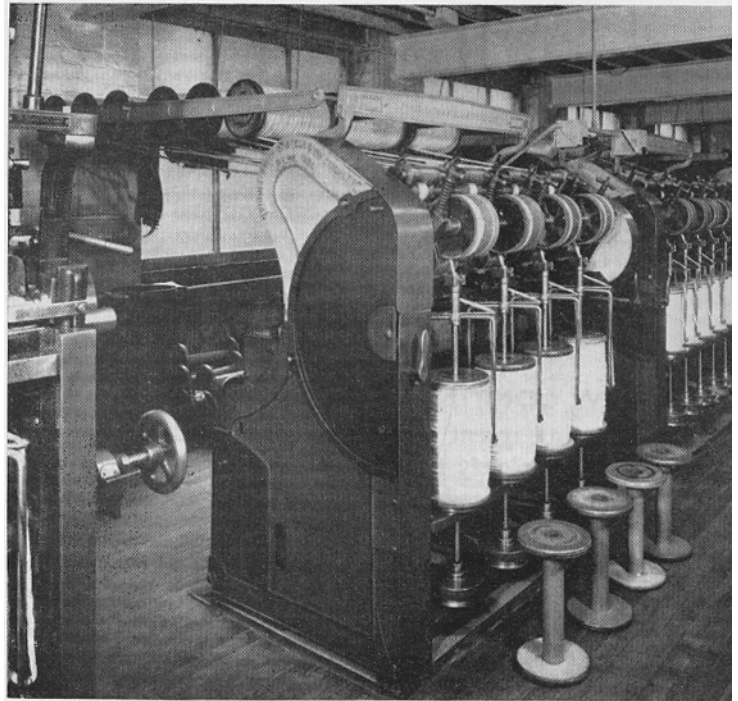

Open drawing boxes showing doubling and drawing operations. In this instance slivers from each set of six bobbins on the rack are being drawn between the front and back rollers and wound on to one of the four vertical bobbins.

(Courtesy: Wool (and Allied) Textile Employers' Council)

First gilling operation in French or Porcupine drawing. Each separate set of slivers shown at the back is mixed and blended together and then wound on to each of the three balls at the front of the machine.

(Courtesy: Wool (and Allied) Textile Employers' Council)

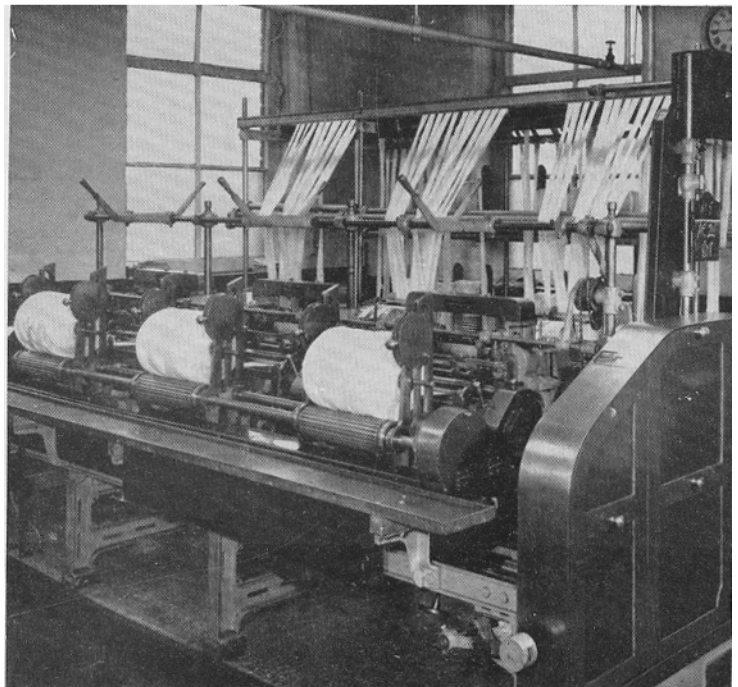

The third operation may consist of a conventional Bradford Open drawing box to produce a heavy weight twisted roving of 40 drams/40 yds from three doublings to make a round roving suitable for the Ambler Super draft (ASD) spinning frame producing fine to medium count yarns.

A further operation on a conventional cone reducer box is necessary to produce a 15 to 18 drams/40 yd. roving suitable for high-draft apron spinning covering a medium count range.

NEW CONTINENTAL DRAWING

During recent years Continental machine makers have completely re-designed the "Porcupine" drawing set and have reduced the series of between nine and eleven conventional operations to four by incorporating an Autoleveller unit in the first high-speed gill box and by omitting the low-draft "porcupine" drawing and roving boxes. As with former Continental processing, dry combed tops are used and twistless slivers are maintained to the final roving box. This new set consists of three operations of high-speed gill boxes followed by a high-draft double-apron Continental roving box.

Vertical firms produce autolevelled top slivers in large cans for feeding the drawing set. In addition, another stage of autolevelling is carried out at the first high-speed gill box in the drawing together with the use of a low number of doublings at each subsequent operation to produce a level roving.

The main difference between the new Continental machines and their counterparts in older sets lies in the fact that the high-speed gill boxes have no back rollers but use a pair of ancillary rollers for feeding the slivers together before they enter the intersecting faller bed. Forty eight fallers work the wool at each head and 1,500 faller drops per minute can be obtained. Triple front rollers, in place of leather aprons, enable closer settings to be made to the fallers, controlling the shorter fibres more effectively. The gilled slivers then pass into large coiler cans for feeding to the next operation.

The final operation is a high-draft roving box. This machine is similar in construction to a conventional Continental rover with the exception of the "porcupine" which is replaced by double aprons within the drafting zone. These double aprons have a linear speed slightly in excess of the back rollers to keep the fibres straight and sandwich the roving completely, thus controlling the movement of the fibres as they are conveyed into the front roller nip. In this way high drafts are obtained.

After leaving the front rollers, the roving passes through a pair of conventional rubbing leathers which have a lateral and rotary movement to consolidate the fibres into a round structure before it is finally wound onto a double meche ball, assisted by a calender roller.

The roving is similar in every respect to that produced on the "Porcupine" system for spinning into lofty open yarns for hosiery and soft spongy cloths.

Typical Layout of Drawing Sets

OPEN DRAWING

Long wool set producing 4,000 lb. per week of 8 drams/40 yds, for 1/20s counts. (44 tex.)

No.	Operation	Doublings	Drafts	Wt. in drams per 40 yds.	No. of Heads or Spindles
1	Can gill box -	6	6	420	2
2	Spindle gill box -	5	6	350	2
3	Drawing box -	5	7	250	4
4	Weigh box -	4	8	125	8
5	Finisher box -	3	9	42	16
6	Rover box -	2	10.5	8	96

CONE DRAWING

Merino wool set producing 6,000 lb. per week of 2.5 drams/40 yds. rovings for 1/48s counts. (18 tex.)

No.	Operation	Doublings	Drafts	Wt. in drams per 40 yds.	No. of Heads or Spindles
1	Can gill box -	6	6	288	4
2	Cone spindle gill box -	5	6	240	4
3	Cone Drawing box	5	6	200	6
4	Cone Weigh box -	4	6.2	129	8
5	Cone 1st Finisher box -	3	6.4	60	24
6	Cone 2nd Finisher box -	3	6.5	28	48
7	Cone Reducer box	2	6.6	8.5	192
8	Cone Rover box -	2	6.8	2.5	432

PORCUPINE DRAWING

Merino and fine crossbred wool set producing 7,000 lb. per week of 5 drams/40 yds. rovings for 1/30s counts. (29 tex.)

No.	Operation	Doublings	Drafts	Wt. in drams per 40 yds.	No. of Heads
1	1st Intersecting gill box -	6	6	256	3
2	2nd Inter. gill box	6	6	256	3
3	3rd Inter. gill box	4	6	170	4
4	Drawing box -	3	4.5	114	6
5	Reducer box -	2	4.5	51	12
6	Slubber box -	3	4.2	36	16
7	1st Intermediate box -	4	4.2	34	16
8	2nd Intermediate box -	3	4.5	23	24
9	Rover box -	2	4.4	10.4	40
10	Finisher Rover box	2	4.2	5.0	80

NEW BRADFORD DRAWING

Merino and fine crossbred wool set producing 6,000 lb. per week of 40 drams/40 yd. rovings for ASD spinning or 15 drams/40 yd. rovings for Apron-draft spinning.

No.	Operation	Doublings	Drafts	Wt. in drams per 40 yds.	No. of Heads or Spindles
1	Autoleveller Bradford gill box - -	12/16	6	810	1
2	Autoleveller Pressure Drafter Draw box - -	1	9	90	10
3	Bradford Open Finisher (for ASD Spinning)	3	6.75	40	30
4	Bradford Cone Reducer (for Apron draft spinning)- -	2	5.3	15	120

NEW CONTINENTAL DRAWING

Merino and fine crossbred wool set producing 6,000 lb. per week of 14 drams/40 yd. rovings for double apron spinning to 1/24s count (37 tex.)

No.	Operation	Doublings	Drafts	Wt. in drams per 40 yds.	No. of Heads
1	Autoleveller High-speed gill box -	8	8	300	1
2	High-speed gill box	4	8	150	2
3	High-speed gill box	3	8	56	4
4	High-draft double apron Continental rover -	2	8	14	40

Autoleveller Pressure Drafter Draw Box, showing the sliver passing from the back measuring rollers, through the pressure draft unit to the front rollers in the drafting zone.

(Courtesy of Prince-Smith & Stells, Ltd.)

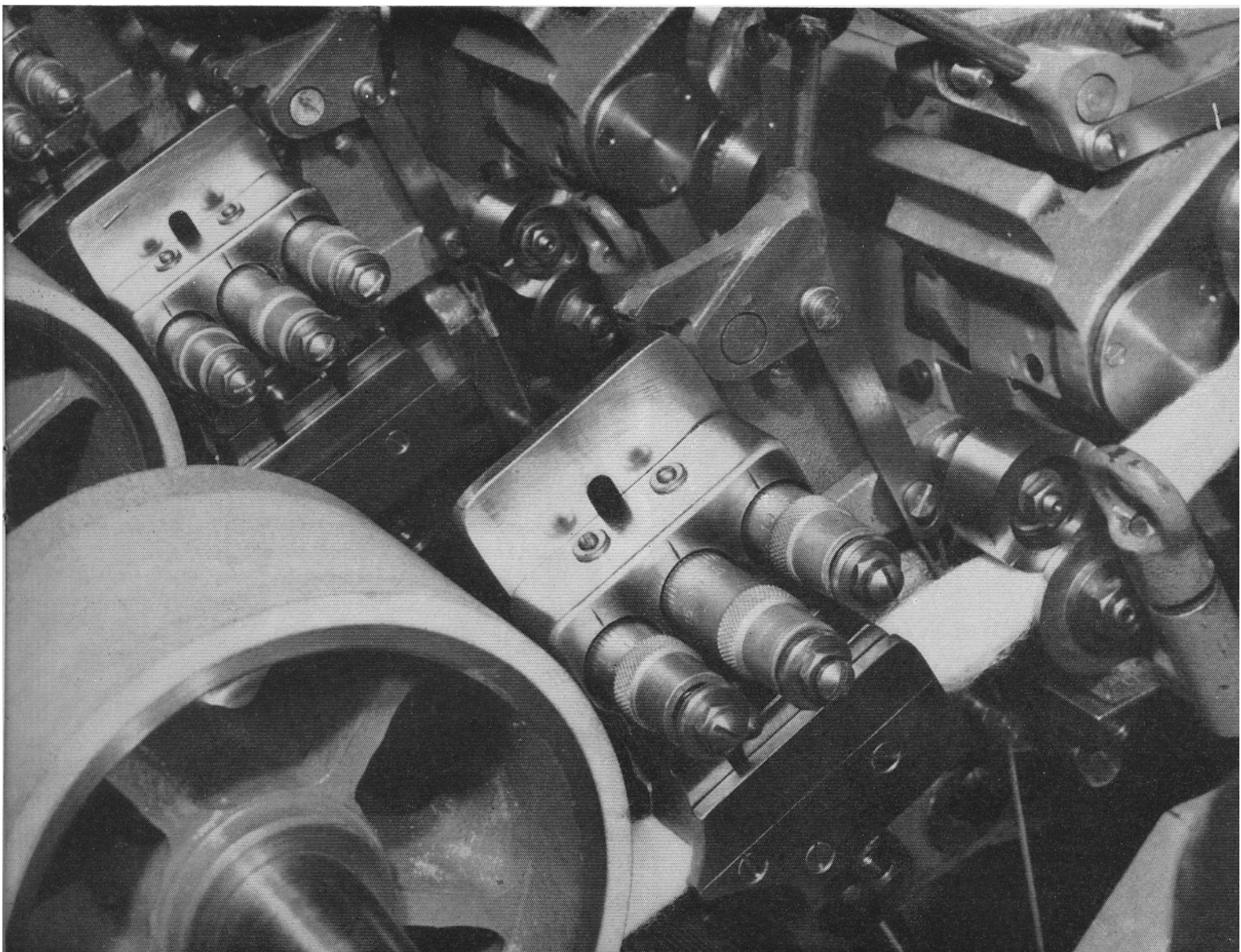

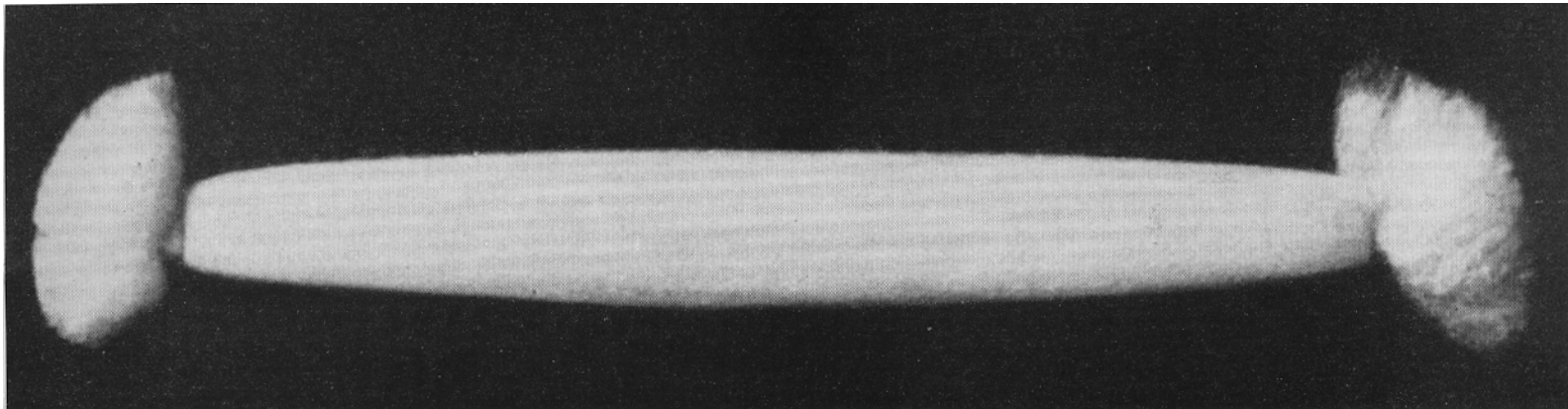

THE MANUFACTURE OF WORSTED YARNS

PART II — FROM FINAL ROVING TO WORSTED YARN

H. BEEVERS, F.T.I., C.G.I.A.,

Head of Department of Textile Industries, Keighley Technical College

MODERN spinning is essentially a single operation, having developed from the old hand methods in use before the industrial era. As spinning constitutes the last drafting operation, the machines are constructed to convert rovings into yarns of a specified degree of fineness, indicated by a count number,* while sufficient twist is inserted by a revolving spindle which twines the fibres together until they are strong enough to be wound on to bobbins, spools or paper tubes. Additional twists may be inserted to conform to the basic requirements of certain yarns, such as:

- (a) Soft twist – chiefly for lofty hosiery yarns.
- (b) Mid. soft twist – mainly for weft yarns to give a soft handle to fabrics.
- (c) Mid. twist – warp yarns, to achieve strength, rigidity and elasticity in the cloth.
- (d) Hard twist – chiefly for special structure or colour effects such as crêpes, colour twists, marls, etc.

In the worsted industry there are four well established types of spinning frame: flyer, cap, ring, and mule. The first three are known collectively as “throstle” frames, because of the peculiar whirling sound made by the spindles. On these types, drafting, twisting and winding the yarn on to the bobbins is done concurrently, and they normally follow the Bradford drawing system, whereas in the mule the functions are carried out consecutively in the same order. The mule is described as an intermittent spinning unit and is used solely for converting Porcupine drawn rovings into yarns. However, many years ago the Continental ring frame was introduced to take similar rovings, and is

*The count of a yarn is a measure of its fineness. On the Universal Tex count system it is defined as the weight in grammes of one kilometre (1,000) of yarn.

Thus: If one kilometre of yarn weighs 44 grammes, this yarn is 44 Tex count.

The higher the count, the coarser is the yarn.

now growing in popularity because it is more economical and much easier to operate than the mule.

In all these spinning machines the general principles underlying roller drafting are practically the same, with the exception of the means of controlling the shorter “floating” fibres within the drafting zones. There are three main systems:

1. Low draft system used since the Industrial era and in wide use today, where drafts are applied in relation to the maximum fibre lengths measured in inches, e.g. 5 to 12 draft. In this system, as shown at Fig. 1, two or three lines of carrier rollers and tumblers are situated between the major drafting rollers. The only difference being in the weight of the tumblers. Polished wood is used for twisted rovings, while metal is preferred for twistless rovings. Continental ring spinners and mules are fitted with small diameter rollers to achieve adequate fibre control in the absence of twist in the rovings.
2. High-draft systems introduced around 1950 enable drafts from 15 to 20 to be applied. These employ either single or double aprons arranged to control fibres close to the front roller nip, as shown at Fig. 3. Situated between the apron rollers and the back roller is a line of carrier rollers. The top roller is lightly loaded and covered with a soft barrel-shaped cot to encircle partially the roving and control the maximum number of longer fibres. The single apron system is generally used for soft twisted rovings and the double apron system for twistless rovings on large package ring spinners for the production of soft twisted yarns.
3. Ambler Super Drafter device was invented by Geoffrey Ambler of Bradford. The first prototype model was constructed in 1947 and since its development has completely revolutionized drafting principles. In this system, as shown at Fig. 2., a

wide range of drafts can be applied from a thick slubbing of 40 drams/40 yd. to produce a full range of commercial counts from 44 tex to 11 tex. The means of controlling the fibres within the ASD unit is by a small pair of intermediate rollers which feed the roving through a tapered flume situated close to the front roller nip. The intermediate rollers and flume are capable of simultaneous adjustment. As the draft is increased the flume moves towards the front rollers.

On delivery of the yarn from the respective drafting zones, the major distinctions lie in the methods of imparting the twist and winding the spun yarns onto the bobbins.

FLYER SPINNING

We have already considered briefly the flyer and bobbin actions under "Open Drawing"† and the flyer spinning spindle looks like a roving spindle box in miniature. Although this method represents the oldest system of modern spinning, it has certain limitations. It is best adapted for producing thick counts from coarse quality wools, as no other type of spinning is capable of making superior smooth yarns from these materials. This is due to the comparatively slow spindle speed of approximately 2,500 r.p.m. when wrapping the yarn round the flyer leg during its passage to the bobbin.

Cap Spinning with Ambler Super Drafting Zone. Top front rollers and upper parts of units have been removed to show the roving passing between them.
(By Courtesy of the Principal, Keighley Technical College.)

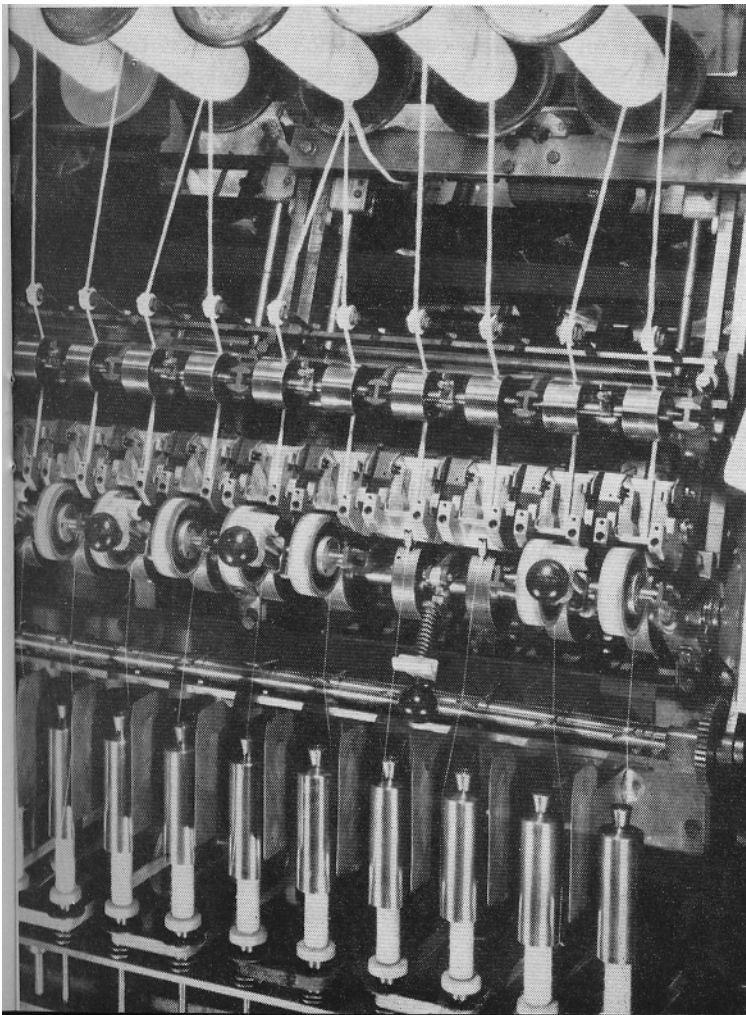

In recent years, however, the flyer frames have been reconstructed for automatic doffing (replacing the full bobbins with empty ones), work formerly done by juvenile labour which is no longer available to the industry. In one of these modified frames, as shown in Fig. 1, the flyer A and spindle B are detached, the former being accommodated in ball bearing C fixed below the yarn guide board D, and driven by means of tape E. While the "dead" spindle allows free rotation of the bobbin F, it is riveted to the lifter plate G. A duplicate lifter plate G₁ with spindle B₁ and empty bobbin F₁ is necessary to allow the bobbin "change-over" to be accomplished both effectively and speedily. Later the full bobbins are taken off the duplicate spindle plate and replaced with empty bobbins during spare periods while the frame is running.

CAP SPINNING

The introduction of the cap spindle in the nineteenth century completely revolutionised spinning at that time. because much higher speeds of 6,000-7,000 r.p.m. could be attained and finer yarns spun. However, this type is restricted to merino and fine crossbred wools, as a "wild" yarn results from lower grades which balloon in the air during the insertion of twist and winding on to the bobbin.

† See page 29.

Flyer Spinning with Low Drafting Zone. Top front rollers and tumblers have been removed to show the roving passing between them.
(By Courtesy of the Principal, Keighley Technical College.)

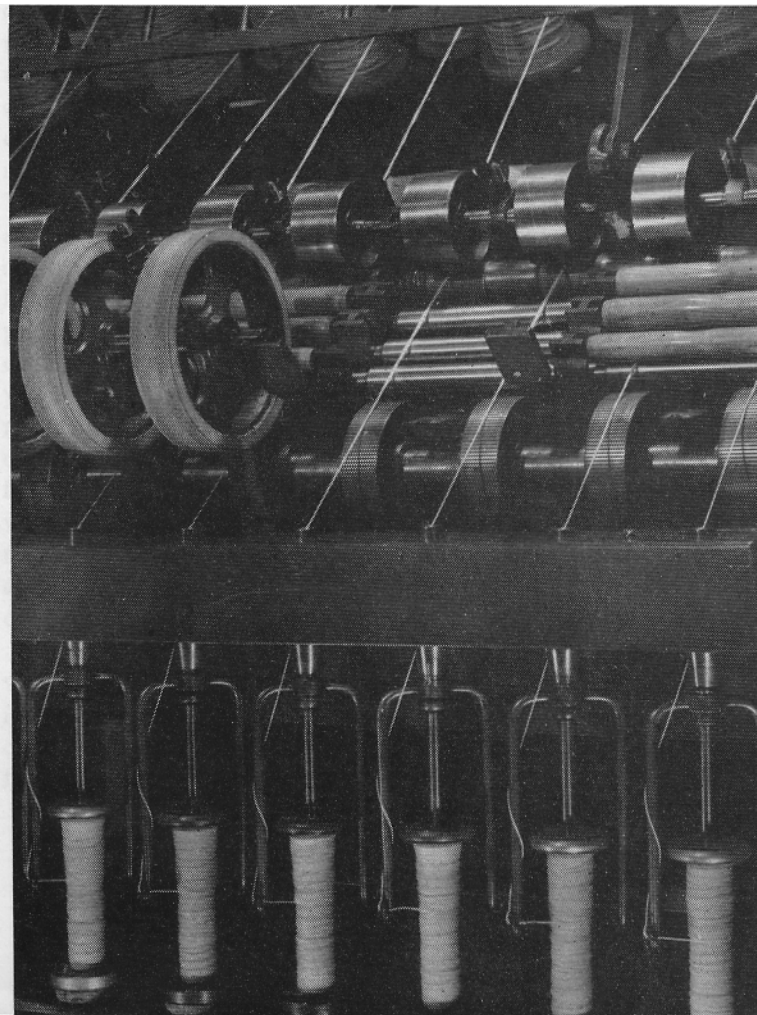

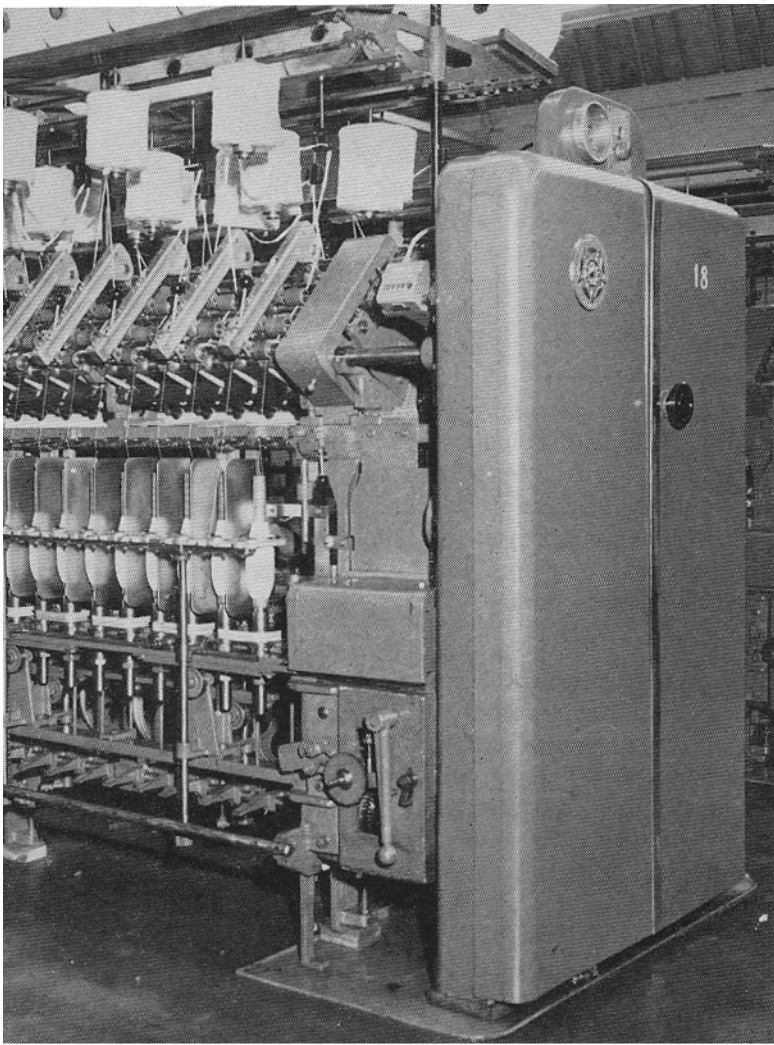

Ring Spinning with Single Apron High Drafting Zone.
(Courtesy: Prince-Smith & Stells, Ltd.)

the surrounding air which deflects and retards its movement.

This aerial drag can be regulated to spin a wide range of counts, simply by interchanging the sizes of cap and bobbin diameters, by adjusting the distances between the yarn guide H and cap edge, and by lowering the spindle rail. All these factors influence the ballooning capacity of the yarn. A small cap and bobbin, both raised to meet the guide above, will create a small balloon and produce minimum strain, so desirable in fine count spinning. On the other hand, thick, strong yarns capable of withstanding greater strains can be spun more economically with large caps and bobbins, as the latter will hold a greater weight of yarn.

RING SPINNING

Although the ring spindle was invented soon after the cap spindle, its early use was restricted to producing yarns from Porcupine drawn rovings. Since 1930, however, these frames have been redesigned with larger diameter rings and dual lifter plates, with a view to building larger packages to follow the Bradford drawing systems. For this reason the ring spindle is extremely useful for spinning lofty yarns ranging from medium to coarse counts, mainly from merinos and fine crossbred wools, for machine and hand-knitted goods. Since a number of machines are made to meet the requirements of both Bradford and Continental spinners, they all operate under the same principles of twist insertion and winding-on.

As shown in Fig. 3, the spindle A is supported by, and rotates in, a bolster cup B, which is screwed to lower rail C. The bobbin D is placed on the spindle and both revolve together to insert the twist. Each spindle occupies a central position in a ring E fastened to a ring plate F. On the upper flange of this ring a small steel-wire traveller G is free to rotate when directing the yarn on to the bobbin. Thus winding-on is accomplished by the traveller lagging behind to take up the yarn delivered by the rollers H.

It will be observed that tension is applied to the yarn from two sources, namely aerial drag plus the weight of the traveller. Since different sizes of rings are employed, relative spindle speeds can be expected, as the traveller must move at a higher linear speed on a large ring in comparison with a small one for each turn of twist put into the yarn. For practical purposes, rings measuring $1\frac{1}{2}$ inches diameter can be run successfully at 8,000 r.p.m., whereas three-inch rings are restricted to 6,000 r.p.m. Even then some variation in drag is apparent, owing to the rise and fall of the lifter ring plate, which naturally influences the yarn ballooning capacity. But this has been partly overcome on some frames by introducing variable speed motors to counterbalance the fluctuating conditions.

In construction, as shown on Fig. 2, the cap spindle consists chiefly of a "dead" spindle A screwed to a horizontal rail B below. On this spindle a long brass tube C revolves, driven by a tape D on the whorl at the lower end, to carry the bobbin E. Seated on the spindle top is a loose-fitting stationary cap F, whose purpose is merely to guide the yarn as it balloons round before passing to the bobbin. A lifter plate G traverses the tube inside the cap to distribute the yarn evenly on the bobbin. The twist is inserted by the bobbin rotating on its own axis, while one end of the yarn is held between the rollers. Simultaneously the action of winding-on is accomplished by the high speed at which the bobbin revolves, causing the yarn to swing outwards to meet

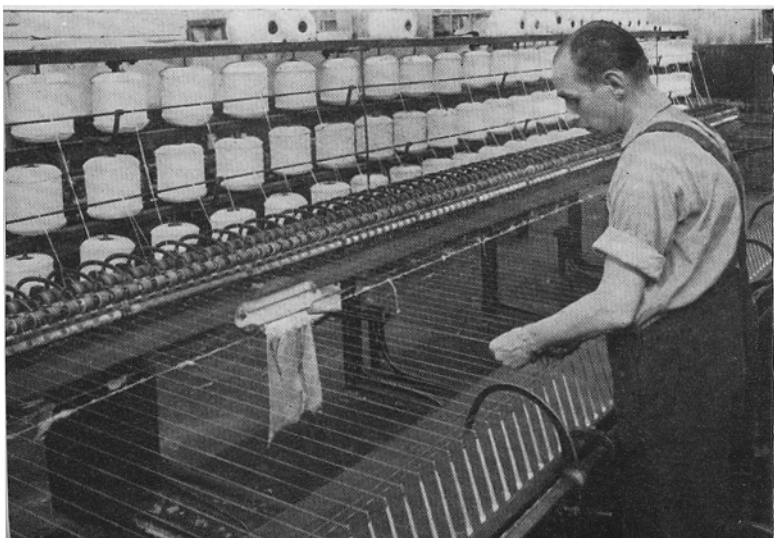

Worsted mule spinning.
(Courtesy: Wool (and Allied) Textile Employers' Council)

Stages in attenuation from top to spun yarn.

1st GILL BOX

2nd GILL BOX

SPINDLE GILL BOX

DRAWING BOX

REDUCER

ROVER

SPINNING FRAME

TWISTING FRAME

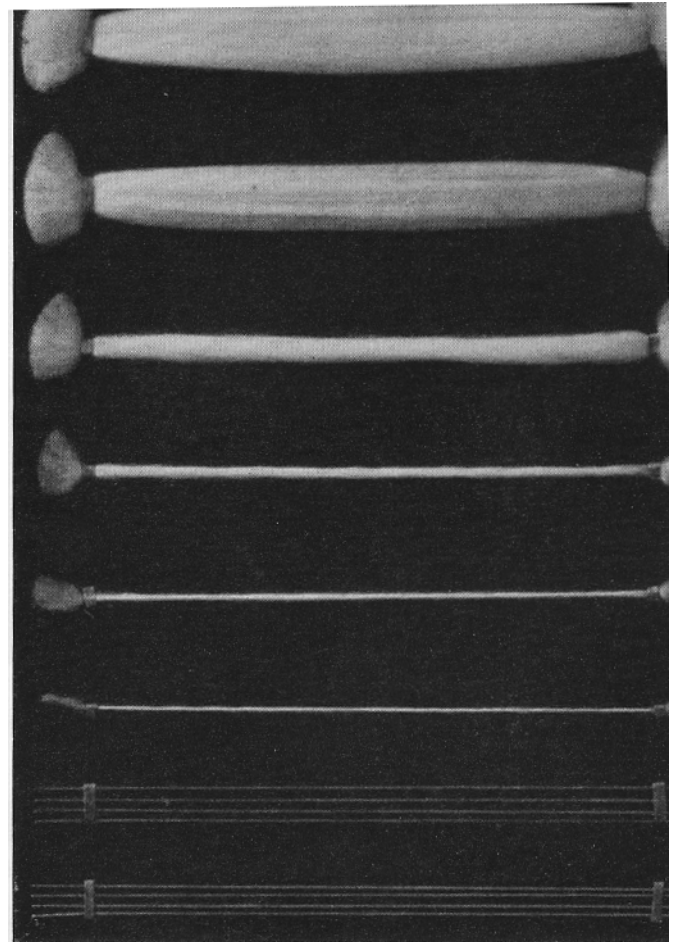

WORSTED MULE

There are two distinct types of mules in the wool textile industry, and the one used for spinning worsted yarns is totally different with regard to drafting the roving, from the woollen mule described by Dr. J. G. Martindale.† It will be remembered, perhaps, that the woollen mule draws out the condenser roving entirely by “spindle drafting”, while the carriage moves away from the single pair of rollers. In the worsted mule, however, ninety-five per cent is accomplished by the standard four-line drafting arrangement. The remaining five per cent, induced by the carriage lead in excess of the front roller delivery, is utilised to promote a further levelling of the yarn by drawing out any potential thick places. But in each type the method of inserting the twist and winding the spun yarns on to paper tubes is practically the same.

In comparison with throstle spinning frames, the mule mechanisms are very complex, and so cannot be explained within the scope of this article. But a brief account of the cycle of movements may suffice to explain the operational principles (Fig. 4).

The rovings from the stationary creel A pass between the lines of rollers B to be drafted to the appropriate fineness. On leaving these rollers the twistless ribbon of fibres proceeds to the revolving spindles C, which put in the twist. These spindles are supported and

driven at an acute angle on the moving carriage D, to permit the yarn to slip over the spindle tip and so distribute the twist along each drawn-out length, as the carriage moves away at the same linear speed as the rollers. Before the carriage reaches the limit of its traverse, say seventy inches, the rollers stop, but the carriage proceeds a further two or three inches to level out the yarn, while the spindles may continue to revolve until the full complement of twist is added. To wind this length of yarn on the cop E, the spindles are reversed, termed “backing-off”, to unwind the coils of yarn from the spindle. This action is assisted by the guiding faller wire F moving downwards to its position for guiding the yarn to the cop, while the counter faller wire G ascends to put tension into the yarn during the winding-on. The carriage now starts to run in, with the spindles rotating in their normal direction, at a variable speed relative to the cop circumference at the winding-on point, as the winding faller wire traverses to build the cop. When the carriage returns to the rollers, both faller wires move out of contact with the yarn and the cycle of movement continues.

Worsted mules are capable of spinning fine yarns as well as coarser ones, owing to their restricted motion in the air and the minimum strains imposed. The constant slipping over the spindle tip causes the shorter fibres to migrate towards the yarn surface to impart a

† “The Spinning of Woollen Yarns”, page 12.

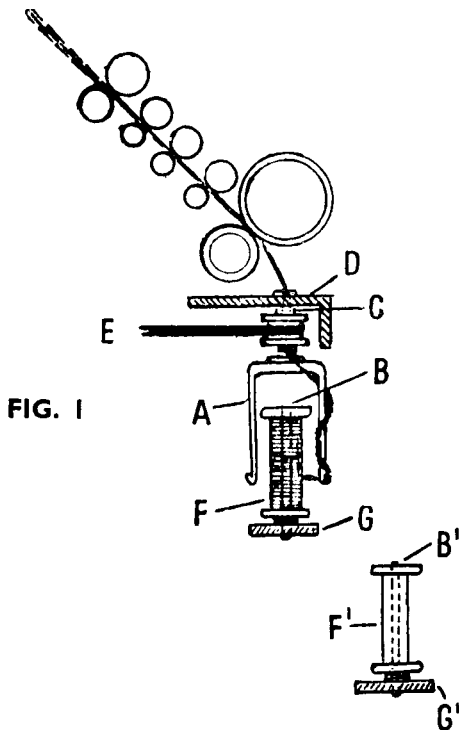

FIG. 1

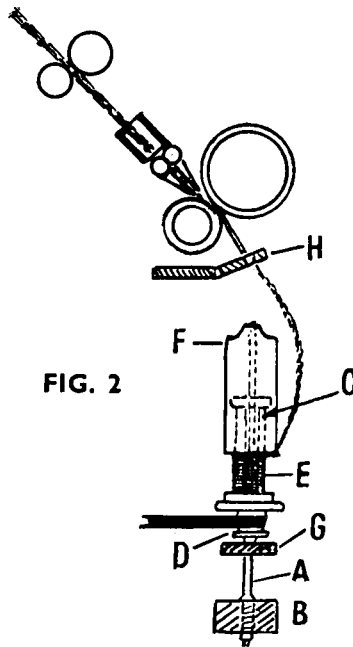

FIG. 2

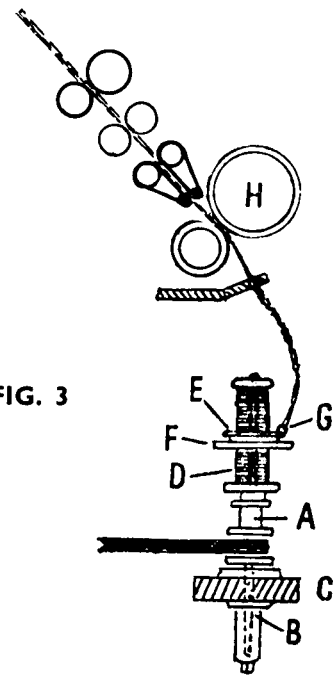

FIG. 3

TYPES OF "THROSTLE" SPINNING FRAMES

FIG. 1 *Flyer spinning.*

FIG. 2 *Cap spinning.*

FIG. 3 *Ring spinning.*

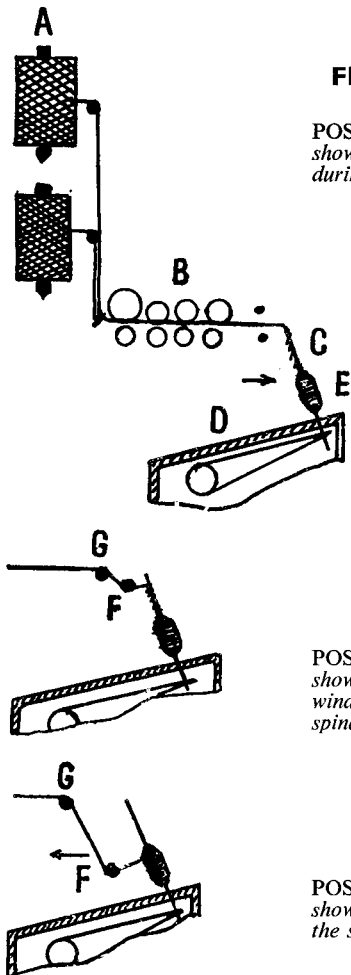

FIG. 4 **Worsted Mule.**

POSITION ONE
shows the carriage moving forward
during spinning.

POSITION TWO
shows the "backing-off", to
unwind the coils of yarn from the
spindles.

POSITION THREE
shows carriage running in to
wind the spun yarn on to the cop.

round, lofty appearance and soft handle. Many spinners claim that mule spun yarns are superior to other types, but the complexity of the machine, the extensive floor space required and the employment of male labour may offset any economic advantages gained. The Continental ring frames, being more accessible and productive, are gradually replacing mules in many of our worsted mills.

FOLDED YARNS

After spinning, a very large proportion of single yarns are twisted together in two or more plies, as they are much easier to manipulate than single yarns of similar thickness. This work is carried out on twisting frames, fitted either with cap, ring or flyer spindles. It is interesting to note, however, that folding is done in the reverse direction to spinning, in order to release an appropriate amount of singles twist and thus produce a more balanced structure in the composite yarn. Much use is made of variable folding twists in creating a wide range of yarns to meet the knitters' and cloth manufacturers' requirements.

Finally, the worsted spinner delivers the yarn to his customers on specified standard style packages. Yarn is directly spun or twisted on to spools for weft, wound on to "cheeses" to prepare warps for the loom, wound on to "cones" for machine knitting and reeled into hanks for hand knitting.