

will be moved outwards to carry the belt on to the fast pulley F, and the machine will then start. At the same time a small pin in the sliding bar 98 pushes the spiral spring 100 to the left and compresses it ready for it to exert its stored energy when required.

It is a usual plan to have a few old cards on the pegs T under and behind the needles to facilitate the starting, and to remove these cards subsequently. As the feed-wheels J and J¹ move slowly round, the attendant takes the cards, one by one, from the pile, and inserts them in successive order on the pins T. As long as she can feed the cards quick enough, and all the lacing twines 63 and 90 keep intact, the back part of the treadle K is kept down. If, however, a lacing twine breaks or runs off, or the pile of cards is used up, or any other condition should arise which demands the stoppage of the machine, she simply releases her foot pressure on the back part of treadle K, when the compressed spring 100 forces back its retaining pin and sliding bar 98, and thus places the belt fork in the off-position, as illustrated in Fig. 202.

In order that the operation of lacing may proceed almost continuously and with a maximum output, it is essential that all the lacing twines should be strong enough to withstand the stress, and that they should be free from knots and lumps to enable them to pass freely and easily through the eyes of the needles and the shuttles. Uneven twines are disastrous, for not only do they impede the work by breaking, but they also often cause the needles themselves to break. While strict economy should be practised in every department, and is absolutely essential to success, it is not always economical to use the cheapest twines for lacing, and particularly for machine lacing.

The lacing twine for the needles may come from balls such as the one shown on the floor in Fig. 197, but, preferably, the twine should be wound on to bobbins, and, during the winding process, should pass through a guide or an eye which will not allow a knot or a lump to pass. The lacing twine for the spools should be taken from the specially wound bobbins for the same reason.

The spools for the shuttles are $4\frac{1}{4}$ in. between the flanges, and the latter are about $1\frac{1}{2}$ in. diameter; the spools, therefore, hold a comparatively long length even of thick twine. The lacing twine is wound on to the spools by the unique mechanism illustrated generally in Figs. 200, 201, and 202, but more particularly in the detailed views of the chief parts in Figs. 211 to 214. Fig. 211 is an elevation from the front of the machine; Fig. 212 is a back elevation; Fig. 213 is a plan; while Fig. 214 is an enlarged view of part of the setting-on motion and part of the automatic stop motion. Referring to Figs. 200 to 202, it will be seen that on the periphery of the disc of cam B is a groove for the round driving belt 101.

This belt drives the outside and loose pulley 102 (see now also Figs. 211 to 214). Fig. 211 illustrates the belt 101 on the loose pulley, while Fig. 212 shows the same belt on the fast pulley 103. When the belt 101 is on the fast pulley 103, the inside pulley 104 is put in action, and the crossed belt 105 drives the lower pulley 106, together with its shaft and the worm 107. The worm-shaft is suitably supported by a projecting bracket from the main support of the winding apparatus. The worm 107 gears with and drives the worm-wheel 108 of about 120 teeth, while forming part of the wheel 108 is a heart cam 109, Fig. 212. A yarn guide 110, fulcrumed at 111, is provided with an anti-friction roller which runs freely in the

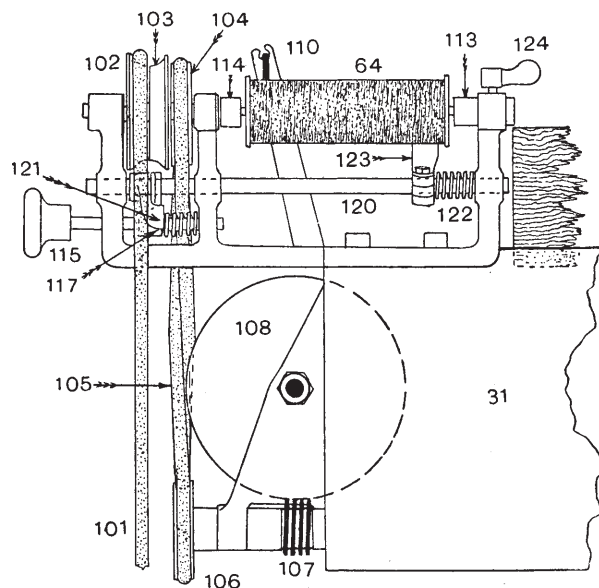

Fig. 211.

Thus, suppose it is required to fill a few spools for the shuttles, an empty spool is placed between the holder 113 and the driver 114, Fig. 202, also plan view, Fig. 213, the twine wrapped round the shank or else caught in a slit in the spool, and the knob 115 pushed in. This action carries inwards a horizontal belt fork 116, Fig. 213, which places the belt 101 on the fast pulley 103, Fig. 212. At the same time the boss 117, Fig. 214, to which the belt fork 116 is attached, compresses the spring 118. The belt fork 116 is kept horizontal by means of a second fork 119, also forming part of the boss 117, the prongs of which are perpendicular to those of 117, and they are kept in this position in virtue of their relation to the rod 120—a prong appearing on each side of the rod. Fixed to the rod 120 is the

heart cam 109, while on the opposite side of the yarn guide is a tension device 112, between the plates of which the lacing twine 63 passes before being carried to the guide itself in the upper part of 110. The direction followed by the lacing twine is clearly seen in the figures.

Since this apparatus is provided with an automatic stop-motion, the spools may be filled simultaneously with the lacing of the cards.

knock-off catch 121, and a projection on the inside of its lower arm slips behind the boss 117 in virtue of the action of the spring 122, Figs. 211 and 212, which always possesses the tendency to keep the knock-off catch in close contact with the boss 117, and also to keep the free end of the lever 123 hard in contact with the empty spool or with the yarn on the spool. It will be seen that the lever 123 is fixed to the rod 120, Fig. 211.

Now, with the various parts as illustrated, it follows that when the knob 115 is moved from the position illustrated in Figs. 211, 213, and 214, to that shown in Fig. 212, the belt 101 will, through the fast pulley 103, start all the spool-winding mechanism. As the heart cam 109 moves slowly round under the influence of the worm 107 and worm-wheel 108, the upper end of the yarn guide will carry the lacing twine from flange to flange of the spool and so distribute it gradually and evenly.

This process will continue from the $\frac{1}{4}$ in. barrel through the various stages, including that of the half-filled spool in Fig. 212, and the subsequent ones, until the spool is filled as illustrated in Figs. 211 and 213. During the gradual filling of the spool, it follows that since one end of lever 123 is fixed to the rod 120, the other and free end will be forced downwards very slowly and

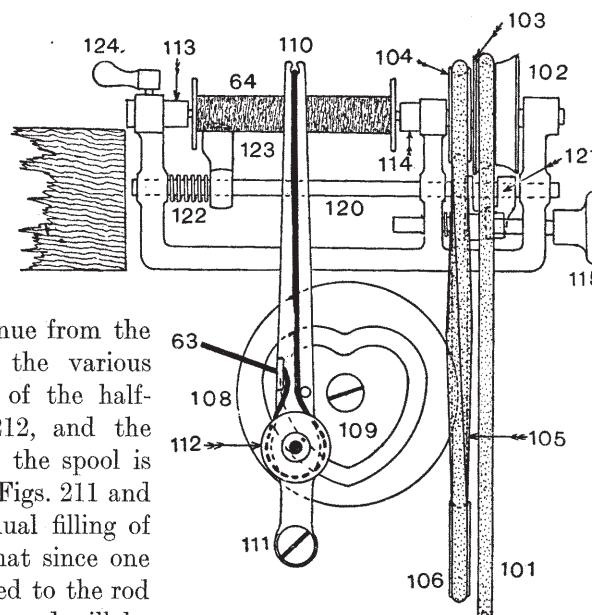

FIG. 212.

in proportion to the increasing diameter of the spool and twine. It also follows that this action will cause the rod 120 to rotate slightly and extremely slowly, but still to move, and in doing so it will impart a proportionate movement to the knock-off lever 121, Fig. 214. This exceedingly slow movement continues until the catch at the back of the lower arm of the knock-off lever clears the periphery or flattened part of the boss 117. This is naturally timed to happen when the spool is full, and it is clear that when the connection between the boss 117 and the knock-off catch is broken the former will be forced to the left, that shown in Figs. 211, 213, and 214, through the action of the spring 118, and thus the belt fork 116 will carry the belt 101 to the loose pulley 102, and the

spool will remain motionless until the operator can remove it from its grips. The holder 113 is held in position and loosened when required by the hand-screw 124. The mechanism requires delicate setting, but when once properly fitted, it performs the winding and the automatic stopping elegantly and accurately.

When the lacing twine becomes exhausted in any of the spools in the

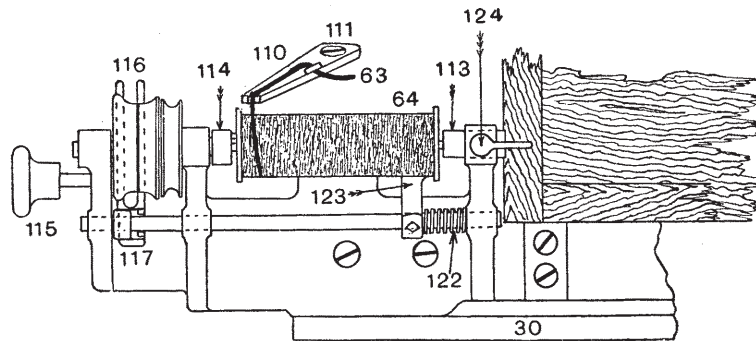

FIG. 213.

shuttles, the latter must be withdrawn from its carrier in order to introduce a full spool. The machine must obviously be stopped for this purpose, and turned by hand until the shuttle carriers are in the full forward position as indicated in Fig. 202. The longer arm of lever 125, fulcrumed at 126, is then depressed until the back and shorter arm is raised clear of the erections 127. The lever 125 as a whole, as well as the upper shuttle grip

128, can then be rotated about the stud 129 until the grip 128 is approximately vertical; when this has been done, the shuttle can be withdrawn from its carrier, and replaced again after it has been supplied with a full spool.

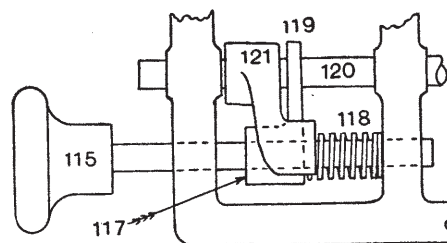

FIG. 214.

Another very successful card lacing machine is that known as Parkinson's "Rapid" machine,

and now made by Messrs. John T. Hardaker, Ltd., Bradford. All lacing machines are provided with mechanism which moves the cards intermittently according to the space between the lace holes in the card and the distance between the centre of the gap between successive cards and the outside hole on the card. In this particular machine these essential movements are made by cams and a ratchet-wheel in conjunction with the necessary intermediate lever and two card carriers.

Thus, Fig. 215 illustrates the cams which are employed for the lacing of cards for Brussels-carpet looms, and for other cards of the same size in

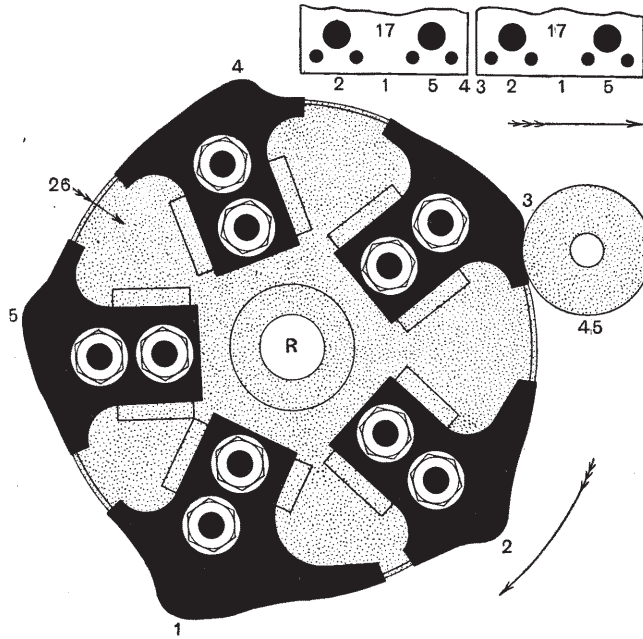

FIG. 215.

which four lace holes appear at each end of the card ; while Fig. 216 shows the ratchet-wheel which is used in conjunction with these cams.

The five cams are shown in solid black in Fig. 215 and bolted to the disc 26, and slight variations in the throw of each cam are possible by sliding the cam between the pair of guides so as to place it nearer to or farther from the centre R. The ends of two cards for Brussels-carpet cards appear in the upper part of the drawing ; both are numbered 17. During the lacing operation the cards move from left to right, as indicated by the straight arrow, while the disc 26 and the five cams move clockwise, as shown by the curved arrow. No. 3 cam is just going to act against the anti-friction bowl 45, and when the latter is forced outwards the intervening mechanism between it and the ratchet-wheel V, shown in Fig. 216, causes the ratchet to move clockwise from point 3

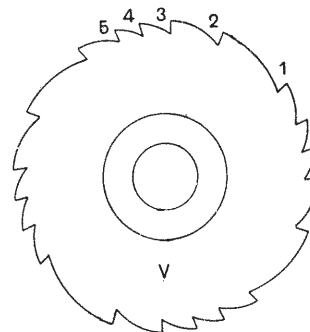

FIG. 216.

to point 4, and so on with each succeeding cam. Each cam in Fig. 215 is numbered to correspond with the similar numbers on the ratchet-wheel in Fig. 216, the cycle of movements, 1 to 5, causing the ratchet-wheel on the card chain shaft to move the card-carrier chains, and therefore the cards 17, through the distances indicated by the same numbers, 1 to 5, on the cards in Fig. 215. It will thus be seen that one complete revolution of the disc 26 and the cams is made for each card, but that the ratchet-wheel, Fig. 216, makes one revolution for four cards, since the group of five teeth for one card is repeated four times on the ratchet-wheel.

Different cams are used for moving the card-carrier chains when it is

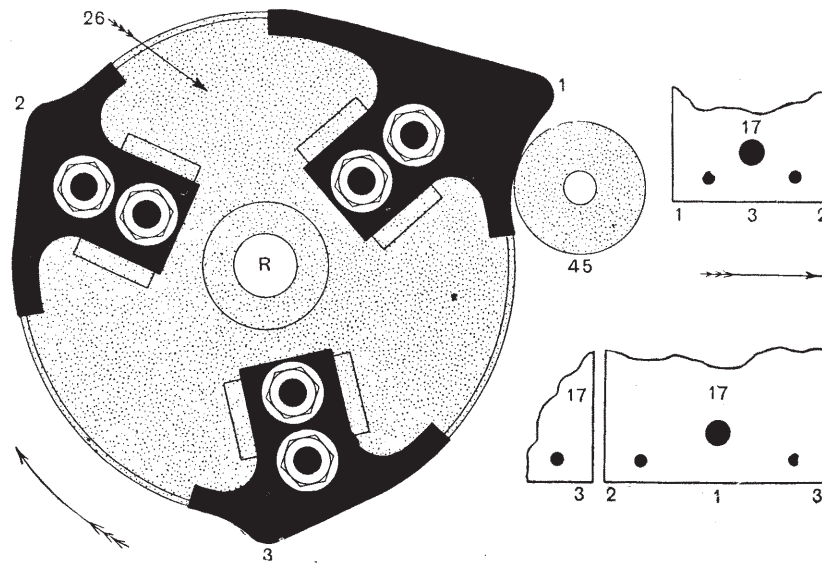

FIG. 217.

necessary to lace cards for 400's and 600's jacquard machines. Fig. 217 illustrates the three cams for 600's jacquard cards, part of two of which appear in the bottom right-hand corner. Cams 1, 2, and 3 cause the ratchet-wheel in Fig. 218 to move through the distances represented by the same numbers, and the card to move through one wide gap on the card, and two shorter gaps as exemplified. Cams 2 and 3, Fig. 217, are used for moving the 400's cards through the corresponding spaces, but a cam smaller than the one marked No. 1 must replace this one, because the distance between the holes in the 400's card at the top of the drawing is shorter than the corresponding distance between the holes in the 600's card at the bottom of the drawing.

In all cases it is found desirable to release a brake on the card chain

shaft when the cams and the ratchet-wheel are acting, and to apply the

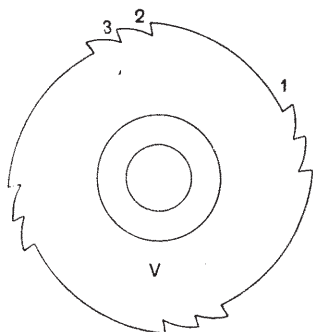

FIG. 218.

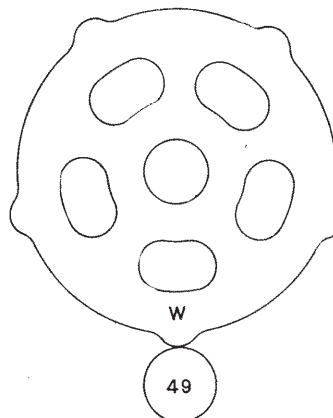

FIG. 219.

brake when the motion is completed. The cam W and bowl 49 for operating the lever to the brake are illustrated in Fig. 219; the position shown is that when the brake is off.

A general photographical view of the machine, taken from the back, is illustrated in Fig. 220.

The elevations of the feed and delivery sides of the "Rapid" machine appear first because the main driving shafts are most clearly exhibited in these views, which are reproduced in Figs. 221 and 222 respectively. In both views the driving belt A is on the loose pulley B, adjoining which is the usual fast pulley C, both pulleys being placed on the short driving shaft D. On the extreme end of this driving shaft is a balance and hand-wheel E, while on the inner end of the shaft is a small pinion F of 28 teeth; this pinion is shown best on the feed side in Fig. 221, but is shown in Fig. 222 a little wider than the actual width in order to emphasise its position in that view.

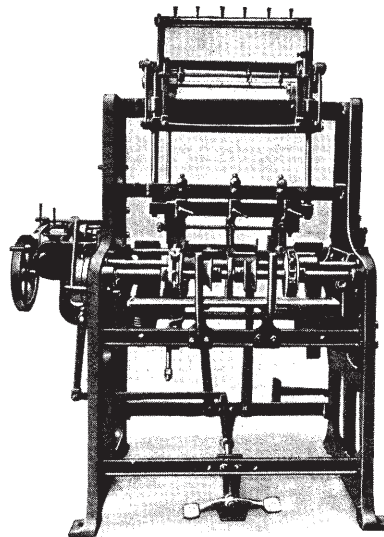

FIG. 220.

The driving shaft is supported by two brackets G and H fixed to the

frame J. The small pinion F drives the wheel K of 75 teeth on the main shaft L of the machine. Not far from the frame opposite to the driving end, and on the same shaft L, are two pinions M and N of 18 teeth and 28 teeth ;

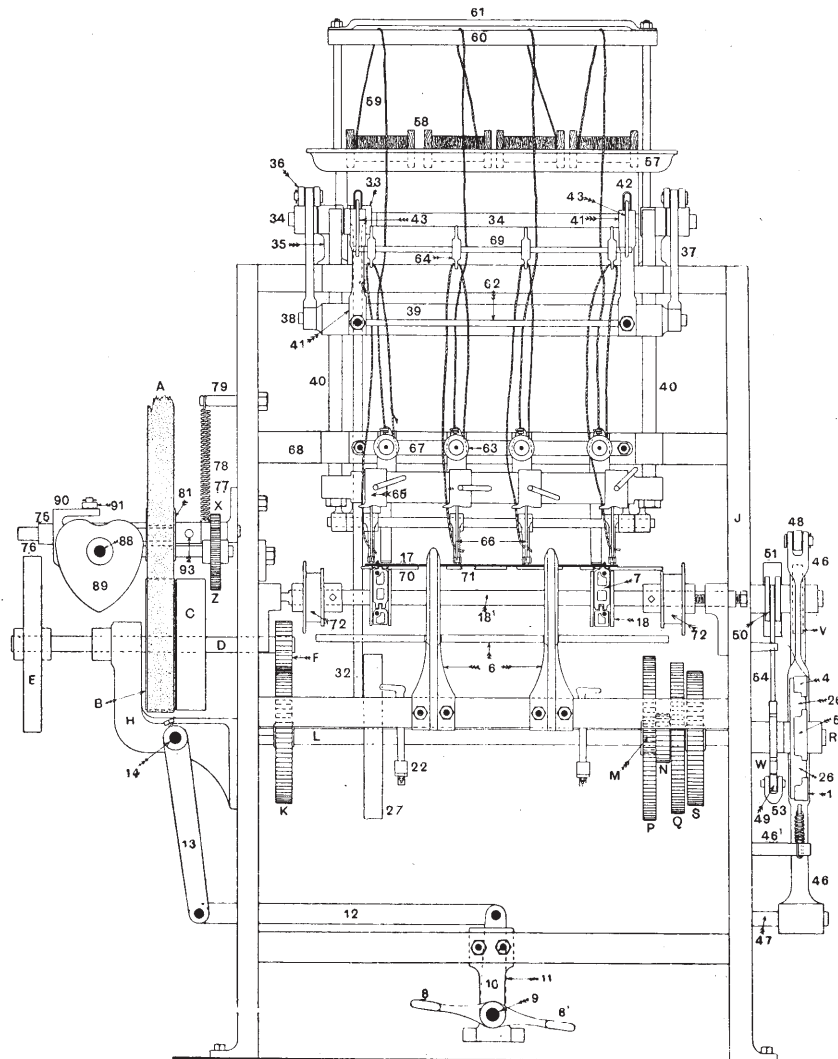

FIG. 221.

both pinions are fixed on the extended boss O. Pinion M is intended to drive, and is shown geared with, the wheel P of 90 teeth, while pinion N is intended to drive at other times the wheel Q of 84 teeth. When this change is necessary, the boss O is slid to the left in Fig. 222, a movement

which would withdraw the pinion M from gear with the wheel P, and

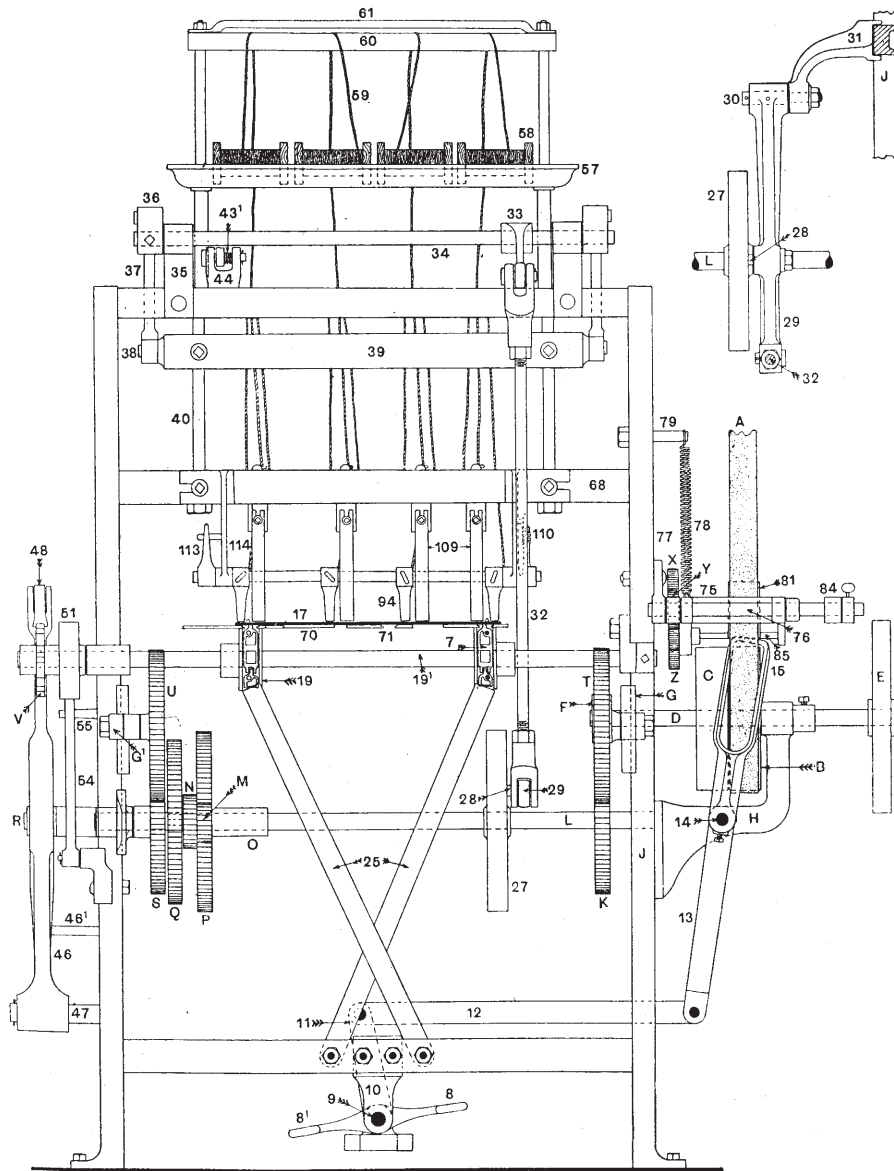

FIG. 222.

place the pinion N in gear with the wheel Q. Both wheels P and Q are on the camshaft R; this shaft is not shown clearly in Figs. 221 and

222, but it is the shaft which carries the cams illustrated in Figs. 215 and 217.

On the above-mentioned shaft L, and beyond the pinions M and N, is a wheel S of 75 teeth, and identical with the wheel K near the frame at the driving side. Wheel K gears with wheel T, Fig. 222, and wheel S with wheel U; the wheel T is supported by a stud near the end of the bracket G, while the wheel U is supported in a similar manner near the end of the corresponding bracket G¹. Both brackets G and G¹ project from, and are bolted to, the outer edges of the frame J.

The cards 17 to be laced are placed in the receptacle 6 (seen clearly in Fig. 223), near which the attendant stands in order to feed the cards on to the pins or pegs of the chains 7, and to be able to control quickly and easily the treadles 8 and 8¹. The combined treadles are fulcrumed on a shaft 9, which extends to the delivery side of the machine, and is supported at the two places by brackets 10. Near the cross-rail of the delivery side, and inside the framework J, is a lever 11 secured to and rising from the shaft 9. A connecting-rod 12, Figs. 221 and 222, connects the upper end of the lever 11 with the lower end of lever 13 fulcrumed on the stud 14. The belt-fork 15 is also fulcrumed at 14, and hence, when the left-hand treadle 8, Fig. 221 (the right treadle in Fig. 222), is depressed, it follows that the levers and rods shown will cause the belt A to be placed on the fast pulley C by the belt-fork 15. Two cards 17 are in position in Fig. 223, and are supposed to have been taken from the pile illustrated on bracket 6. A longitudinal view of a single card is shown in each of Figs. 221 and 222.

The two endless card chains 7 bridge the gap between the adjustable chain carriers 18 and 19 on the shafts 18¹ and 19¹, pass partially round them, and under an adjustable tension roller 20, Figs. 223 and 224. The tension roller 20 is supported on a pin near the end of lever 21, and the rear end of the latter is loose on a pin in the bracket 22. The bracket 22 is supported as shown on the long flat bar 23, which is fixed to and near the cross-rail of the machine. A spring 24 connects the pendant arm of lever 22 with the adjustable part in the bracket 22, thus providing a flexible connection. When the laced cards reach the delivery side of the machine their edges pass on to the inner discs of the chain carriers 19, and the cards are thus lifted from the pegs of the chains 7 to be finally guided to the floor or into some suitable receptacle clear of all obstructions by the two guides 25, Fig. 222.

A rectangle 27, Figs. 221 and 222, is shown on the main shaft L. This rectangle is simply the side elevation of a box or positive cam, an enlarged view of which appears in Fig. 225. Running in the groove of the cam is an anti-friction roller, which rotates on a pin 28, Fig. 222, supported by a

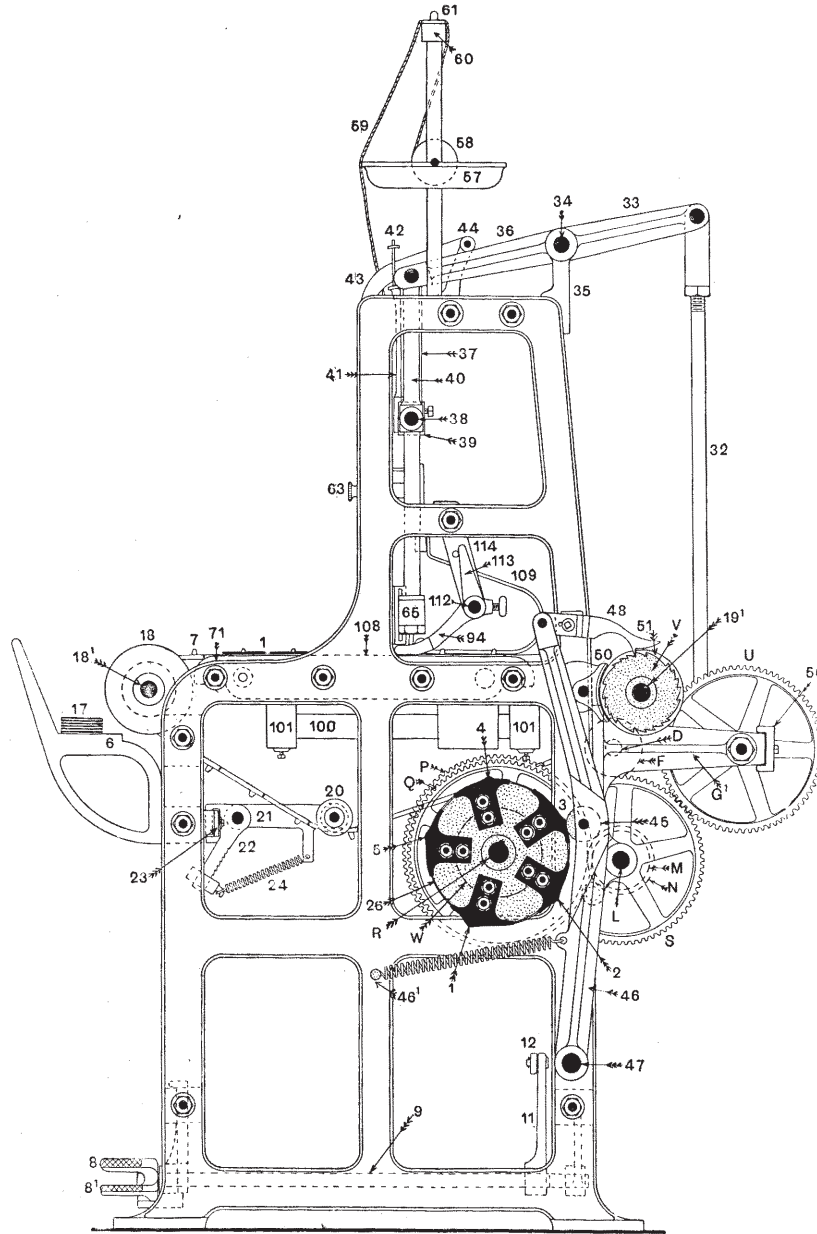

FIG. 223.

lever 29. A plan view of this lever and cam appears in the right-hand upper corner of this figure. Here it will be observed that the pin 28 is

placed about two-thirds of the length of the lever from the fulcrum 30,

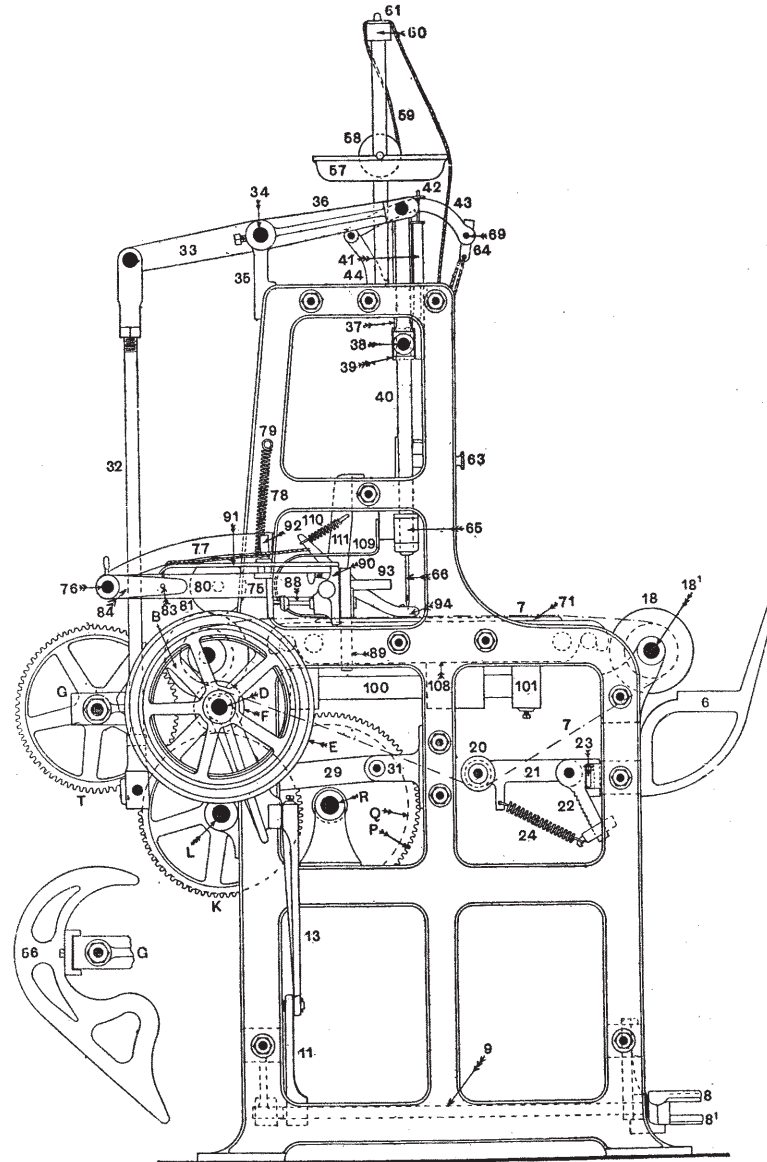

FIG. 224.

the fulcrum pin being fixed in a bracket 31 which is bolted to the middle upright web of the frame J.

Attached to the end of the lever 29 is a connecting-rod 32, the upper

part of which is coupled to a lever 33 fulcrumed on the rod 34. This rod stretches across the machine, is supported by two brackets 35, and carries two levers 36, one near each end. The free ends of the two levers 36 are connected with the pendent arms 37, Figs. 223 and 224; and holes in the lower end of the latter enable them to encircle the studs 38 at the extreme ends of the horizontal rail 39, Fig. 222. A circular hole near each end of the rail 39 allows it to be raised and lowered in a true vertical plane by sliding on the two upright guide rods 40.

Fixed to the front of the rail 40, Fig. 221, are two arms 41, while at the top of each arm is an inverted U-shaped wire 42, and between the two legs of each wire the thread take-up lever 43 can move freely. Each thread take-up lever 43 is fulcrumed on a pin in the bracket 44. It will thus be seen that as the shaft L rotates, the box-cam 27 will cause the rod 32 to operate the levers and arms 33, 36, 39, and 41, and will thus convey the desired movements to the thread take-up levers.

One complete cycle of movements of the thread take-up mechanism takes place every revolution of the box-cam 27 on the main shaft L, and a similar cycle takes place with the needles and shuttles. The mechanism

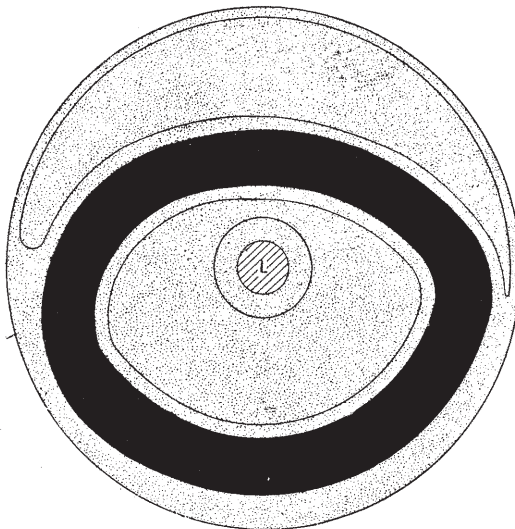

FIG. 225.

for the latter will be described and illustrated later. And for each cycle of movements of the needles and the shuttles the jacquard card must be moved a distance between successive holes on the card, or the distance between the last hole in one card and the centre of the gap between it and the next card. It therefore follows that the speed of the chain-carrier shaft 19¹ will depend upon the number of lacing holes in the width of the card.

The disc 26 is provided with five cams for the cards used in the Brussels-carpet jacquard, and hence there must be one revolution of the shaft L for each of the cams 1, 2, 3, 4, and 5, or five revolutions of the shaft L for one complete revolution of the camshaft R. It has already been pointed out that pinion M, Fig. 222, has 18 teeth and wheel P has 90 teeth; hence,

since the speeds of the shafts are inversely proportional to the numbers of teeth in the wheels on the shaft, it follows that

$$\frac{\text{Revolutions of shaft R}}{\text{Revolutions of shaft L}} = \frac{1}{5}; \text{ or}$$

$$\frac{M}{P} = \frac{18}{90} = \frac{1}{5}, \text{ the ratio required.}$$

When the disc 26 has three cams, as exemplified in Figs. 218 and 220, the pinion N, Fig. 222, must be in gear with the wheel Q, when the ratio of the shafts R and L will be

$$\frac{N}{Q} = \frac{28}{84} = \frac{1}{3},$$

because the shaft L must in this case make three revolutions for each revolution of the cam-shaft R.

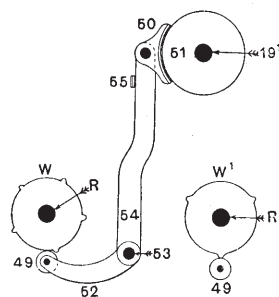

FIG. 226.

As the camshaft R revolves (see Fig. 223) the five cams, 1, 2, 3, 4, and 5, working clockwise, come successively against the anti-friction roller 45 in the lever 46, fulcrumed at 47; and, since the upper end of the lever 46 controls the adjustable pawl 48, it follows that the latter will cause the ratchet-wheel V to move the varying distances necessary for correct lacing. The adjustment of the end of the pawl 48 is so that the extreme end can be set to make sure of moving to the next tooth each time; the distance through which the pawl actually moves depends obviously upon the strokes of the various cams on the disc 26. After the lever 46 has been released by the cam, it is returned into close contact with the disc 26 by means of a spiral spring attached to the lever 46 and to a stud 46' projecting from and fixed to the end frame.

The brake-cam, together with the remaining mechanism, is illustrated in Fig. 226. The cam W, with five projections (the same cam illustrated in Fig. 219), is for use in connection with the five cams on the shaft R, while the cam W' to the right in the detached view is used in conjunction with the three cams illustrated in Figs. 217 and 220, and with the ratchet-wheel shown in Fig. 218. The mechanism shown in Fig. 226 occupies a position between the frame J, Fig. 223, and the disc 26; hence the method of illustrating this part in Fig. 226.

As the cam-shaft R rotates, the projections on the brake-cam W operate on the anti-friction bowl 49 in unison with the action of the five cams on the anti-friction roller 45 in lever 46. In Fig. 226 the brake 50 is on, the

leather face gripping the brake-wheel 51. One of the projections on the cam W is just about to act, and when this occurs it is evident that the anti-friction roller 49 will cause the lever 52, fulcrumed at 53, to move slightly counter-clockwise, and simultaneously the brake lever 54, on the same fulcrum, will make a corresponding angular movement in the same direction, and will thus create a gap between the brake 50 and the brake-wheel 51 just when one of the five cams on the disc 26 commences to move the anti-friction roller 45. When the projecting point of the cam W leaves the anti-friction roller 49, a double flat spring 55 forces the brake 50 again into close contact with the brake-wheel 51.

The wheels T and U, Figs. 223 and 224, stand well out from the frame J because of the function which they have to perform, and which will be described and illustrated shortly; the operative is protected from these wheels by suitable guards when she has occasion to perform any duty at the delivery side. One of these guards is shown detached at 56 in Fig. 224; part only of the corresponding one is shown bolted, or, rather, set-screwed to the bracket G¹ in Fig. 223. In some machines the shaft R extends across the frame, and in these cases a bracket is placed on the frame as indicated in Fig. 224.

The upper lacing twine, if on cheeses or bobbins, may be placed on a rod in a suitable position. When the lacing twine is in balls, each ball may have a separate bowl, or all may be placed in a long dish 57, Figs. 221 to 224, in similar positions to the bobbins 58; hence a dish is suitable for balls of all kinds.

The upper lacing twine 59 in these figures first passes upwards and between the rods 60 and 61, then downwards behind the rod 62, Fig. 221, through a guide curl, and round the tension apparatus 63. It is then carried upwards in front of rod 62, through an eye in the thread take-up bracket 64 (see also Fig. 224), then behind rod 62, through an eye in the needle-holder 65, and finally through the eye of the needle 66 as exemplified.

In Fig. 221 there are four needle-holders 65 for the four rows of lacing, but any desirable number may be accommodated and placed at any position, since each needle-holder 65 is adjustable on the flat rod 67, Fig. 221. This flat rod is fixed to the cross-rail 68 as shown. Similar provision is made for the adjustment of the thread take-up brackets 64, for all are carried on the rod 69, and the two ends of the latter are operated by the thread take-up levers 43.

The cam 27, Figs. 221 and 222, through rods and levers 32 to 41, causes the thread take-up levers to operate somewhat similarly to that already described in connection with the foregoing lacing machine. The springs 43¹, Fig. 222, acting on the underside of the thread take-up levers 43 help to secure the necessary movements of the latter.

Fig. 227 illustrates a plan of the machine with the upper lacing mechanism and all parts above the needles omitted; it also shows the best view of the cop winding mechanism.

One full-width card is illustrated in each of Figs. 221 and 222, and three

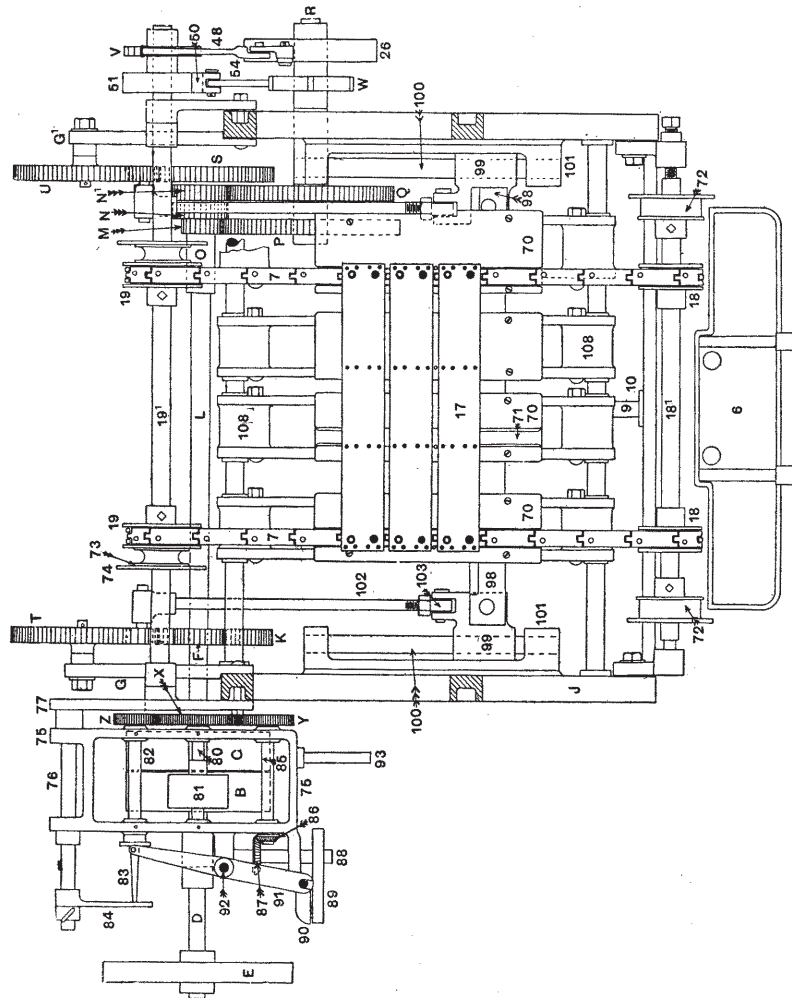

FIG. 227.

full-width cards are shown in Fig. 227, but no lacing twine is exhibited, since the method of lacing has already been demonstrated.

Provision is made for the lacing of shorter cards than those illustrated. In Fig. 227 the two chains 7 are shown in their respective chain races in the plates 70, and in position for conveying wide cards. An extra chain race is, however, shown at 71, and opposite this race either of the chain

guides 18 may be fixed. Enlarged views of a pair of links from each chain appear in Fig. 228. If a chain with larger links is required, say, for wide cards such as those used on a 600's jacquard machine, each link for one chain is similar to that illustrated in the extreme right-hand bottom corner of Fig. 228, and the larger chain guides 72, Fig. 227, placed in position. In addition, the chain conveyers 19 are moved inwards, so that the wide flat surfaces 73 may draw the cards forward, and the larger discs 74 lift the cards from the pegs of the chain 7.

The whole of the mechanism for winding the lower lacing twine is outside the main frame, and supported by a supplementary frame immediately above the pulleys B and C. This supplementary frame 75 is fulcrumed on a shaft 76 in the bracket 77, while a spiral spring 78 from a stud 79 is attached to a hook in the supplementary frame 75, and thus keeps the whole frame and mechanism in the highest position.

A shaft 80 near the middle of the frame carries a leather-faced pulley 81, while on the same shaft and near the main frame is a wheel X of 60 teeth. Wheel X drives two wheels Y and Z of 60 and 28 teeth respectively. Wheel Z is on the shaft 82, and at the other end of the shaft is the spindle 83 upon which the lacing twine is wound in the form of a small-diameter cheese.

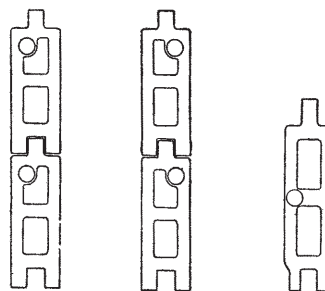

FIG. 228.

The bracket 84 is in the position shown when the winding is in process, but it can be withdrawn from the end of the spindle when it is desired to remove the cheese or cop. Wheel Y drives a further shaft 85, on the end of which is a bevel pinion 86; the latter drives a larger bevel-wheel 87 on the short shaft 88, and on the extreme outer end of the shaft 88 is the box-cam 89. An enlarged view of the cam appears in Fig. 229. An anti-friction roller, supported by the bracket 90, Fig. 227, runs in the groove of the cam 89, and since the bracket is attached to the lever 91 fulcrumed at 92, it follows that the free end of lever 91 will oscillate above the spindle 83. A hole in the free end of lever 91 forms the thread guide.

The lacing twine is first wound round the projecting part of the fulcrum, and then through the eye of the lever 91. The operator allows the twine to run through a tallowed cloth held in one of her hands, and with the other she presses down the handle 93 in the frame 75 until the rotating loose pulley B imparts its circumferential speed to the winding pulley 81. She is thus able to grease the twine and to detect knots at the same time as she is winding the cheeses. It will be understood that no knots are allowed to

pass on to the cheese. When the cheese, which is about $3\frac{3}{4}$ in. long, has reached a diameter of about $1\frac{1}{2}$ in., the handle 93 is released, the mechanism stops, and the cop or cheese is withdrawn from the spindle 83 in the usual way after the bracket 84 has been removed as already explained.

An enlarged view of part of a card for a Brussels-carpet jacquard is shown in Fig. 230 with the presser foot 94 and the needle 95 in position. A grooved wheel 96 is supported by the forked ends of the presser foot. This wheel serves a double purpose: it facilitates the movements of the cards 17, Fig. 227, over the plates 70, and acts as a guide for the up-and-down movements of the needle 95, Fig. 230.

In the plan view, Fig. 227, the wheels M and N are shown in three positions. It will be understood that the letters M and N represent the positions occupied when five cams are used; but when three cams are

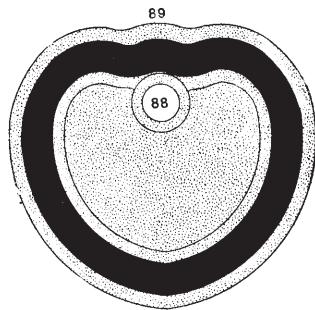

FIG. 229.

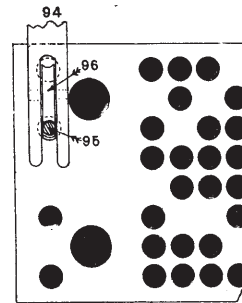

FIG. 230.

used, the wheel N goes to the position marked N¹, and wheel M occupies the position thus vacated by wheel N.

A sectional view of the chief parts of the machine is shown in Fig. 231, and this view, considered along with the part plan view in Fig. 232, illustrates the mechanism for the lower lacing twine. An enlarged view of a needle 95, which, naturally, works in conjunction with the lower lacing mechanism, is shown in Fig. 233. The sectional view, Fig. 231, shows that the needle 95 is approximately in its lowest position, with the thread take-up lever 43 in its lowest position, and the upper lacing twine 59 quite slack. These are the positions of the parts when the tip of the shuttle is just about to enter between the needle 95 and the loop formed by the twine 59 a little above the eye of the needle. It will thus be seen that the shuttle, although not shown in Fig. 231, is supposed to be on the right of the needle, and is, in fact, in the actual apparatus in the shuttle carrier immediately behind the plate 96, to which the shuttle carrier is fixed by two screws as indicated.

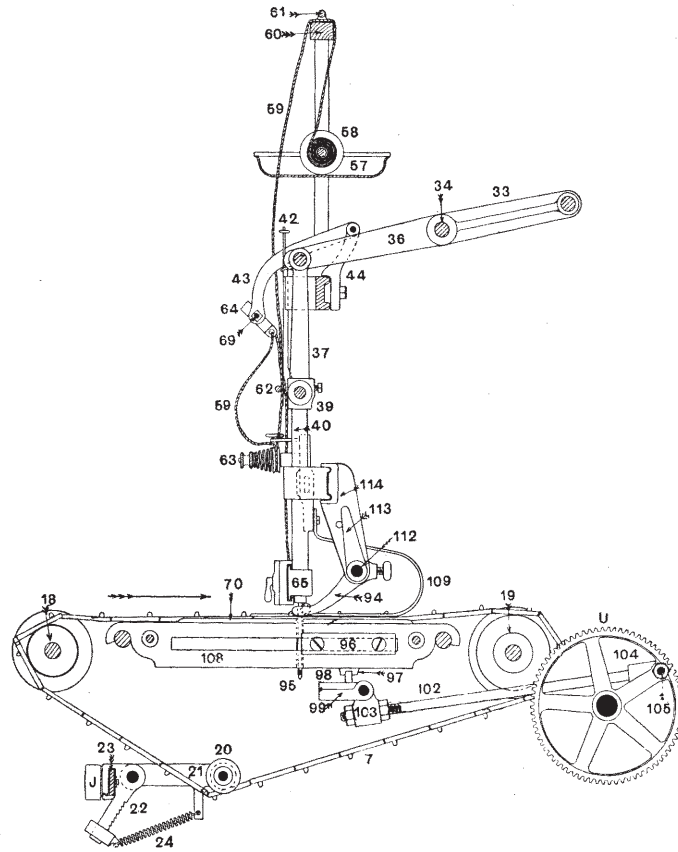

FIG. 231.

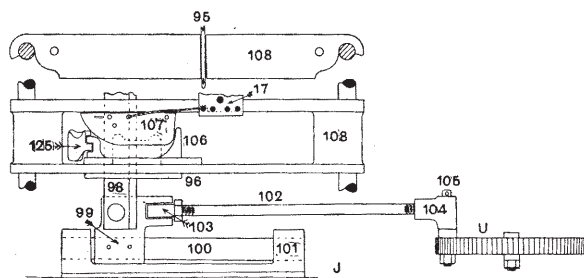

FIG. 232.



FIG. 233.

All four shuttle carriers are obviously in the same plane, and all are connected separately by pendent arms 97 to the flat bar 98 which stretches

T

across the machine (see Fig. 227). Near the ends of the flat bar 98 are bolted two brackets 99, the outer ends of which encircle two shafts 100. These two shafts 100, one at each side of the machine, are secured to brackets 101 on the side frames J, and on these shafts the brackets 99 can slide. The forked part of each bracket 99 is attached as shown in Figs. 231 and 232 to a rod 102 by the swinging bracket 103. The other end of the rod 102 is attached to the bracket 104, and this bracket encircles a stud 105 near the periphery of the wheel U. A similar connection is made at the other side of the machine. It will thus be seen that, since wheels K, S, T, and U, Fig. 222, are equal in size, the wheel U, Figs. 231 and 232, will make the same number of revolutions as the main shaft L. This

is necessary, because the movements of the shuttles must synchronise with those of the needles and the thread take-up levers.

The shuttle carrier 106, Fig. 232, holds the shuttle 107 in the manner indicated. A planed projection of the shuttle carrier passes through the slot in the plate 108, Fig. 231, and this projection is attached to the outside plate 96 by the two screws. As the wheel U rotates, the planed projection slides backwards and forwards in the slot of 108, and thus the desired movements of the shuttle carriers and the shuttles are made.

While the lacing is in progress, springs 109, Fig. 231, in conjunction

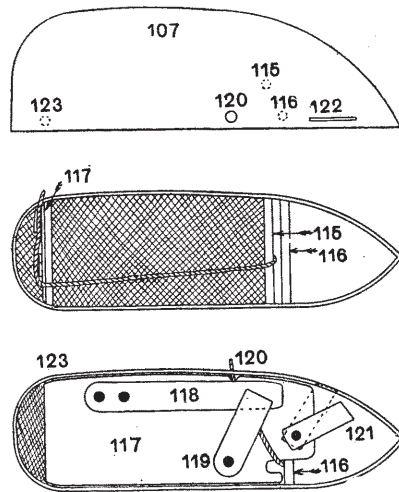

FIG. 234.

with the presser feet 94, keep the cards 17 on the pins of the chains 7, and yield slightly if any obstruction occurs. The presser feet are sometimes held down separately by springs as shown in Fig. 220; but in the line drawing (see Fig. 224) a small spiral spring 110, attached to the bracket 111 and to a projecting arm on the shaft 112, Figs. 223 and 231, serves the same purpose. The lowest position of the presser feet is determined by a similar arm 113 abutting against a projecting pin in the bracket 114.

Three views of the shuttle 107 appear in Fig. 234. The criss-cross marks in the central view represent the cop, and in this view the lid of the shuttle is open. In the lower view, however, the lid is closed, but not fastened down. The thread—or, rather, the lacing twine from the inside of the cop—is first passed between the pins 115 and 116 as shown, and then the lid is closed down. The lacing twine is then passed between the

pin 116 and the slot in the lid 117, under the spring 118, which is kept down by another spring 119, and finally through the hole 120 in the side of the shuttle. The locking plate 121 is now rotated to the dotted position, when its end will have entered the slot 122 in the side of the shuttle. The lid 117 is hinged at 123.

Figs. 235 and 236 are further views of the shuttle and shuttle carrier, with provision for the entrance and withdrawal of the shuttle. The face of the shuttle 107 slides against the part 108¹, just clearing the needle which moves up and down in the slot 124, and through a hole in the plate 70. The card chain moves in the slot.

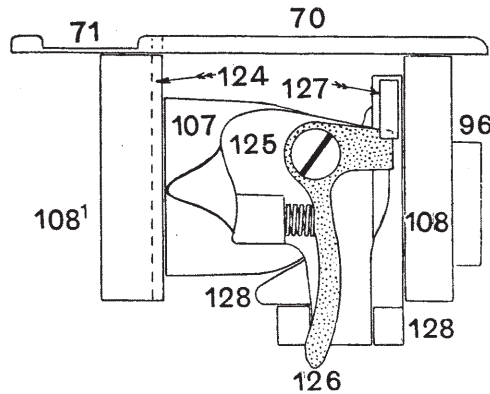

FIG. 235.

In Fig. 232 the shuttle carrier 106 and the shuttle 107 are shown on the extreme left, and at this time the needle would be in the highest position. The hinged end or door 125 of the shuttle carrier is open in this view, and also in Fig. 236.

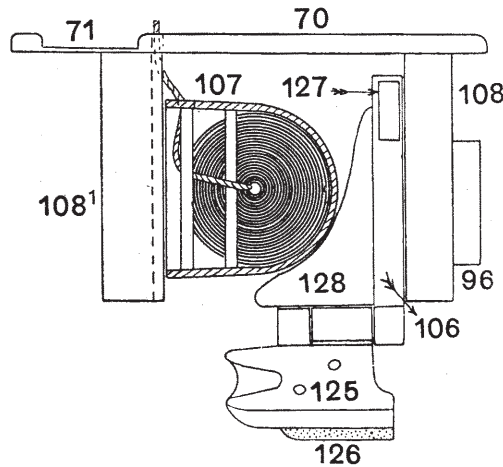

FIG. 236.

Both views show the necessary position of the door when the attendant is putting in a shuttle or taking one out. When the machine is in work, however, the door must be up or closed, as indicated in Fig. 235. It is kept secure in this closed position by a spiral spring which exerts its pressure against the pendent arm of lever 126, shown stippled, such pressure causing the upper arm of the lever 126 to pass behind the fixed retaining part 127. The door is hinged at 128 to the shuttle carrier. To open the door it is only necessary to pull the long arm of lever 126 to the left, when the upper horizontal arm will clearly leave the retaining part 127, and allow the door to rotate to the lowest position as exemplified in Fig. 236.

The shuttle 107, shown in section in Fig. 236, rests as indicated upon two projecting parts 128 of the shuttle carrier 106; one only is shown in this figure, but both are dotted in Fig. 232. When this door 125 is down, the shuttle can be withdrawn to replace a new cop, after which the shuttle is again entered, the door 125 raised, and all is ready for continuing the lacing operation.

The relative positions of the needle and shuttle in Figs. 231 and 232 are indicated in Table IX. :

TABLE IX.

Needle down when the shuttle is on the extreme right.
Needle commences to move slightly when shuttle commences to move to the left.
Needle stops, and remains stationary, while shuttle tip is entering the loop, and also for a time during which the upper lacing twine is drawn through the needle eye to accommodate the increasing bulk of the shuttle.
Needle commences to rise when the shuttle is about one inch from the extreme left.
Needle reaches the top, or nearly so, at the same time that the shuttle reaches the extreme left.
Needle commences to move down when the shuttle has moved about one inch towards the right.
Needle just entering a hole in the card, or the gap between two cards, when the shuttle is opposite the needle or midway in its travel.

The speed of the machine depends naturally upon several considerations. In an illustrated handbook by the makers it is stated that "1000 cards or more per hour" can be laced. Under suitable conditions this number could probably be exceeded with three stitches per card, for the machine from which the foregoing drawings were made was running splendidly at 84 stitches per minute. This means a non-stop production of

$$\frac{84 \times 60}{3 \text{ stitches}} = 1680 \text{ cards per hour ; or}$$

$$\frac{84 \times 60}{5 \text{ stitches}} = 1008 \text{ cards per hour.}$$

Even if 25 per cent be deducted for stoppages, the production is highly satisfactory.

CHAPTER XIV

MECHANICAL METHODS OF STITCHING CARDS

THE card-stitching machine made by the Singer Manufacturing Company, Limited, is very similar in build to that of the card-lacing machine described in the foregoing chapter; it differs from it entirely, however, in the way of forming the cards into a continuous length; the materials which are used to effect the chain-like form of the cards also differ essentially in the two systems of attachment. As already seen, the lacing machine is provided with two balls or two cheeses—as the case may be—of comparatively thick and level twine for each head; this twine may be of some multiple ply twisted in the ordinary way, or it may be made from about eight separate threads braided on the box-cord principle.

On the other hand, each head of the stitching machine combines two narrow tapes—often the braided circular cord flattened—one above the cards and the other below the cards, by means of two fine sewing threads. Such being the case, the mechanism for the stitcher, although similar in some respects to that of the lacer, is of a lighter build.

Fig. 237 is a general photographic view of the machine; it is nearly a full front view of a 4-head machine, but it also shows most of the mechanism on the right hand—the driving side—and a half-full view of the spool-winding mechanism.

The line drawing illustrating a front elevation of the machine is shown in Fig. 238, but in this case only three heads are illustrated. The corresponding line drawing of the driving end of the machine is illustrated in Fig. 239. The machine may, of course, be driven either from above or below, and in both cases the belt from a drum on the driving shaft communicates motion to the stitching machine belt pulley A on the main shaft B, which is made to revolve counter-clockwise when viewed from the driving end as indicated in Fig. 239.

Near to the belt pulley A, Fig. 238, and between it and the frame of the machine, is a hand-wheel C and the cone D. The latter enters a corresponding recess in the driving pulley A, and these two, together with

the treadle E and the intermediate mechanism, enable the operator to start and stop the machine at will. The treadle E is fulcrumed on the rod F, and on the same rod is fixed the lever G, the free end of which is connected to the lower and horizontal arm H¹ of the driving shaft friction

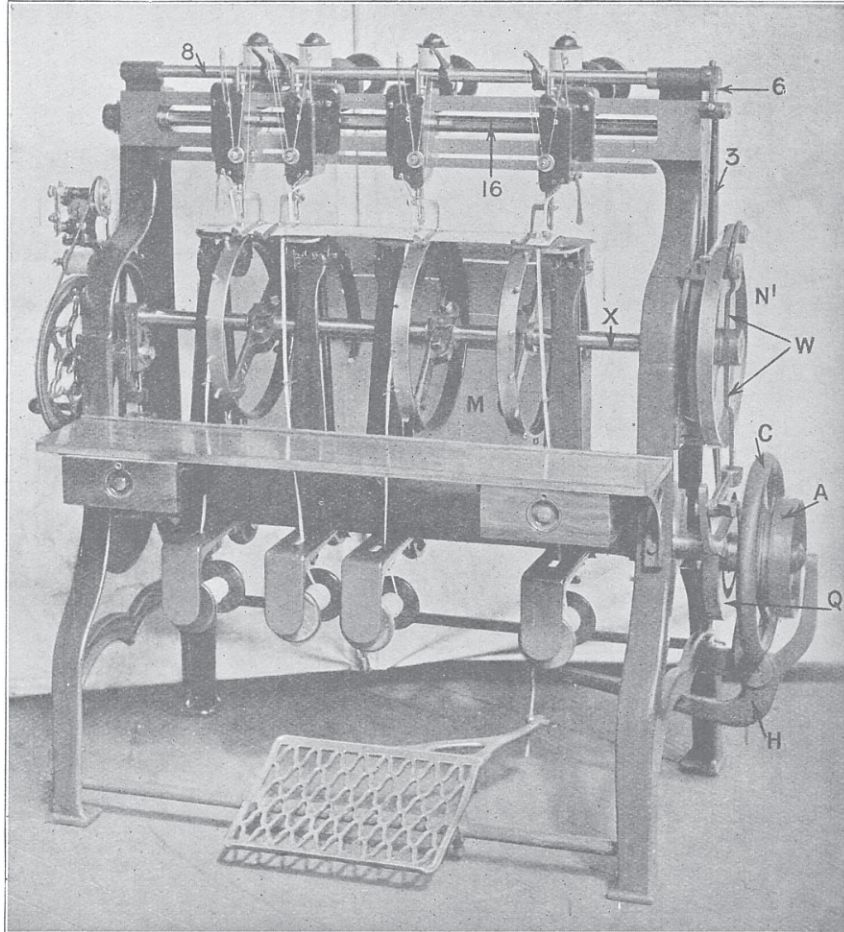

FIG. 237.

lever H by means of the link J. In some cases, as shown clearly in Fig. 237, a projection from the back of the treadle E serves the same purpose as the lever G in Figs. 238 and 239.

The friction lever H, Fig. 238, is fulcrumed at K, and, in addition to its horizontal arm H¹, is provided with two vertical arms H¹¹ and H¹¹¹; the

arm H^{11} is in close contact with the pointed end of the small bush L on the belt pulley A , while the side of the upper end of the arm H^{111} is provided with a leather face to form a brake when it comes into hard contact with the face C^1 on the side of the hand-wheel C . In the absence of any pressure on the inner half of the treadle E —that farthest from the operator—the weighted outer half keeps the treadle in the low position as indicated in all the figures. When the treadle is in this normal position, the leather face of the arm H^{111} is in contact with the face C^1 , but there is a gap between the outer surface of the cone D and the inner surface of the belt pulley A . If, however, the inner half of the treadle E be pressed downwards, it is evident that the lever G will move in unison, and will cause the lever H to make a slight movement counter-clockwise, Fig. 238, while simultaneously with these actions the brake lever H^{111} will be withdrawn from contact with the face C^1 , and the upper end of the long vertical arm H^{11} will push the belt pulley A , and therefore the inner surface of the cone, into close contact with the outer surface of the cone D . The friction thus introduced will start the machine.

It was shown in connection with the lacing machine that it was necessary for the feed-wheels to move varying distances, such distances depending upon the space between adjacent lace-holes on the card, and the space from the last lace-hole on the card to the centre of the gap between adjoining cards. In the machine under notice the peg-wheels cover the same distance each movement, and this distance is much less than that required for the feed-wheels in the lacing machine. In some of the stitching machines—not those of the latest design—the peg-wheels are moved through the necessary distance by means of a feed friction-wheel and friction blocks (see N^1 , Fig. 237), but in the latest type the corresponding movement of the peg-wheels M is obtained by means of a ratchet-wheel N , Figs. 238 and 239, and the usual pawl O , the latter of which is operated as follows: On the main or driving shaft B and near the frame, Fig. 238, is a disc P . A positive or box cam Q , Fig. 240, is cut into the right-hand face of the disc P , and a different box cam 2, Fig. 241, is cut into the left-hand face of the disc. An anti-friction bowl R , Fig. 239, enters the grooved cam Q , while the bowl itself rotates on a pin which projects from the side of the long arm of the lever S fulcrumed at T . The curved and shorter arm of the lever S , Fig. 239, is provided with a concentric slot S^1 , through the medium of which one end of the link U can be adjustably fixed to the curved arm S by the wing-nut V ; the other end of the link U is attached to the lower arm of the feed lever W fulcrumed on the feed-wheel shaft X . The latter is supported by the brackets Y , Fig. 238, which may be raised or lowered slightly for the adjustment of the peg-wheels M by reason of the milled-headed screws Z . The feed-wheels in Figs. 238 and 239 are

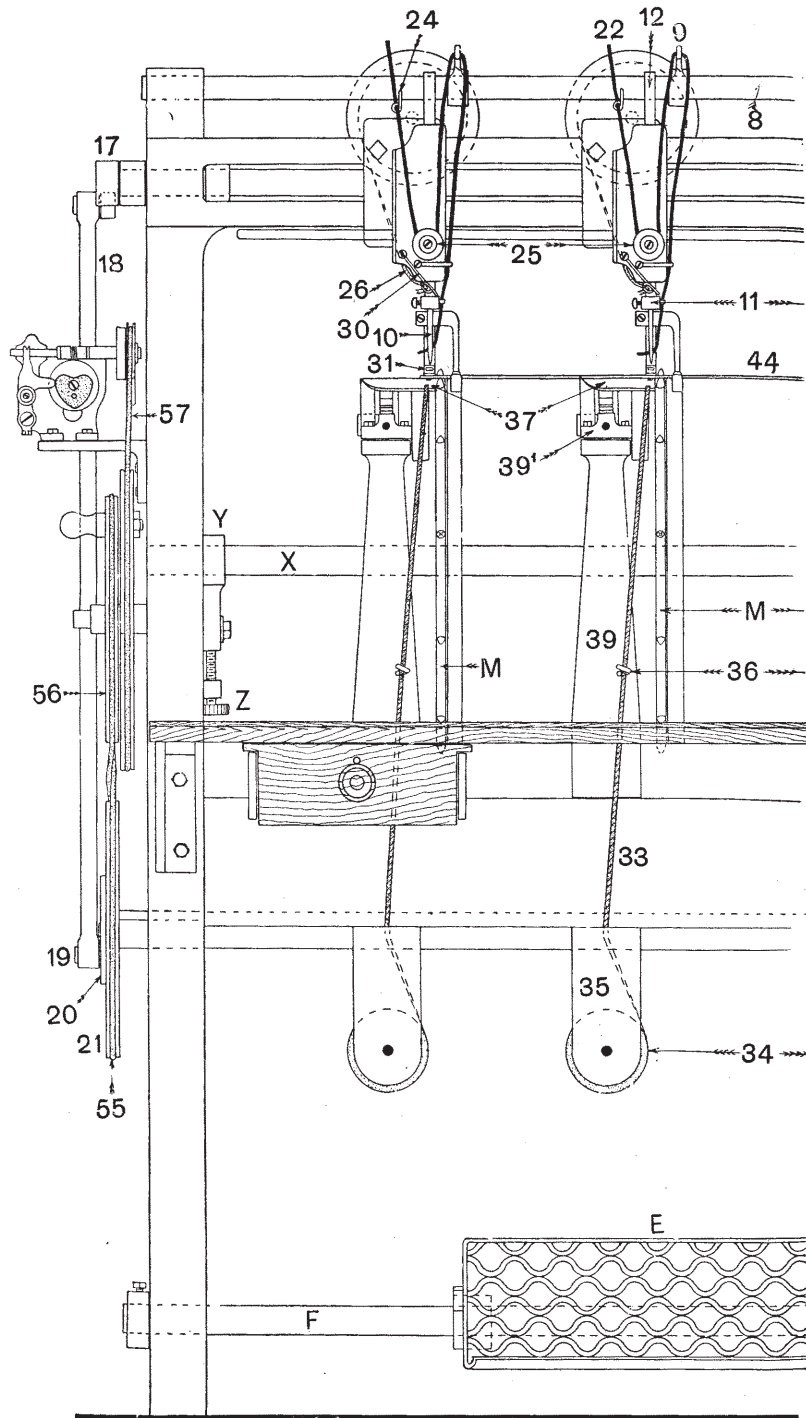

FIG. 238.

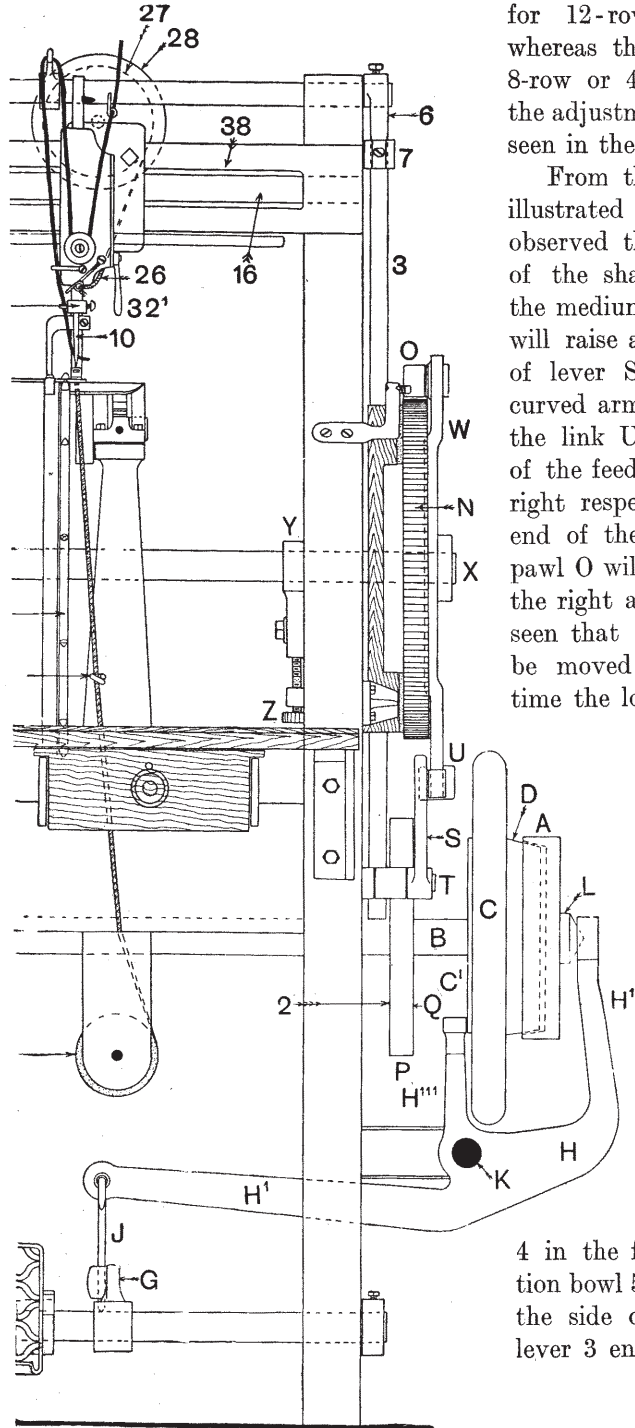

FIG. 238.

for 12-row or 600's jacquards; whereas those in Fig. 237 are for 8-row or 400's jacquards. One of the adjustment brackets Y is clearly seen in the latter view.

From the position of the parts illustrated in Fig. 239 it will be observed that for every revolution of the shaft the cam Q, through the medium of the friction bowl R, will raise and lower the long arm of lever S, and hence the short curved arm of the latter will cause the link U to move the lower end of the feed lever W to left and to right respectively, while the upper end of the feed lever W and the pawl O will move in unison, but to the right and left. It will thus be seen that the ratchet-wheel N will be moved by the pawl O every time the long end of the lever S is raised by the thick part of the cam Q, and that the correct length of movement of the pawl O can be obtained by the proper adjustment of the link U in the curved arm of the lever S.

The cam 2 on the left-hand face of the disc P, Figs. 237 to 241, is for the thread take-up mechanism. The long lever 3, Fig. 239, is fulcrumed on a stud 4 in the framework. An anti-friction bowl 5 on a pin projecting from the side of the lower end of the lever 3 enters the cam 2, while the

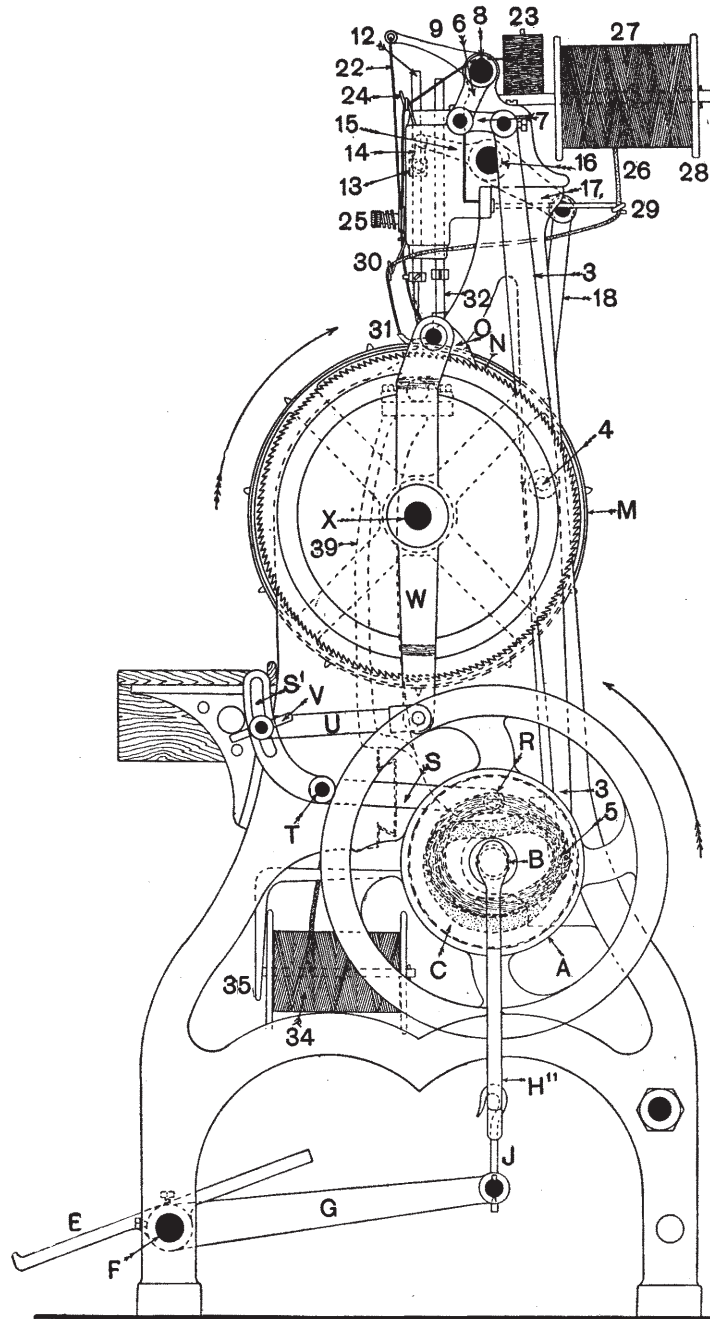

FIG. 239.

upper end of the lever 3 is attached to the thread take-up rock-shaft lever 6 by the link 7. The lever 6 is fixed to the thread take-up rock-shaft 8 by means of set-screws, while a thread take-up lever 9 of the usual kind for each head is also fixed to the rock-shaft 8.

The nature of the movements of the thread take-up levers is similar to that already described in connection with the lacing machine, and need not be recapitulated; it is sufficient to say that as the cam 2 rotates, the lower end of the lever 3 will be moved at the proper times alternately to right and to left, while the upper end of the lever 3 will reciprocate oppositely, and through the link 7 and the lever 6 will cause the rock-shaft 8 to rotate clockwise and anti-clockwise through the necessary angle for the various essential movements of the thread take-up levers 9.

The needle 10, Fig. 238, is connected in the usual way to a needle clamp 11 near the bottom of the needle bar 12. A line drawing of the end opposite the driving pulley is shown in Fig. 242.

On the needle bar 12, and inside the head, is fixed a collar 13, from the side of which a pin projects to provide means of completing

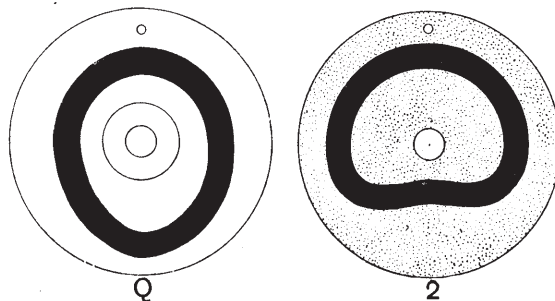

FIG. 240.

FIG. 241.

the connection, through the link 14 and the lever 15, to the needle bar rock-shaft 16. On the end of this shaft—outside the frame—is fixed the needle bar rock shaft crank 17, and from a pin projecting from the side and near the end of the crank 17 is placed the connecting-rod 18. Finally the lower end of the rod 18 is placed on a similar pin 19 projecting from the face of the disc 20 on the grooved wheel 21; the latter is on the reduced end B¹ of the main shaft B. Consequently, as the main shaft B revolves, the needle 10 will be raised and lowered in the well-known manner.

The upper sewing thread 22 for the needle 10 comes from a bobbin or cheese 23, seen best in Figs. 239 and 242; it is passed first through a wire guide 24, then between the discs of the tensioning device 25, up and through an eye near the end of the thread take-up lever 9, and then down to and through a guide on the clamp 11, and finally through the eye of the needle 10. The lower sewing thread will be referred to later.

The tape 26 for the upper side of the card is led from the larger bobbin or cheese 27 (sometimes the cheese is inserted between discs 28), through

the wire guide 29, then through a similar wire guide 30 near the front of the machine, and finally down the guide of the presser foot 31, which is fixed to the presser rod 32. The latter is raised when required by the

handle 32¹, Fig. 238. The tape 33, Figs. 239 and 242, for the underside of the cards comes from a similar cheese or bobbin 34, supported by a pin in the bracket 35, then through a wire guide 36, Fig. 238, and afterwards direct to the needle plate 37.

The heads which support the needles and presser feet are of course capable of being adjusted to any position on the rail 38, Fig. 238, while similar provision is made for the shuttle race supporting arms 39; the latter means of adjustment is shown clearly in Fig. 243, where the lower part of one of the shuttle race supporting arms 39 is shown dovetailed on the rail 40.

Figs. 243, 244, and 247 illustrate the method of rotating the shuttle race pinion 41 by the eccentric 42 on the main shaft B, and the rack 43¹ at the upper end of the eccentric rod 43. Fig. 243 also emphasises the method of lifting the cards 44 from the feed wheels M; this is done by the small bracket 45 secured to the side of the shuttle race 39¹, Fig. 243.

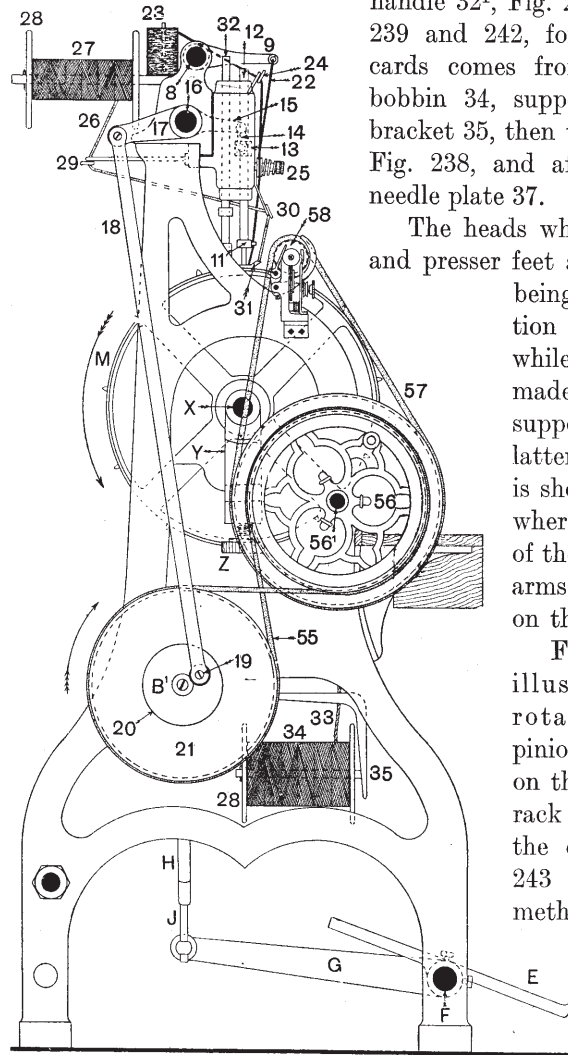

FIG. 242.

Special details of the shuttle race, shuttle carrier, and shuttle are illustrated in Figs. 246 to 258. Two end elevations are shown in Figs. 246 and 247; in the former view the shuttle 45 is in its working position, but in Fig. 247 its position is shown when it is necessary to remove an empty

spool 46, or to insert a full one. In Fig. 247 the empty spool is indicated as leaving the shuttle. The teeth of the rack 43¹ on the end of the eccentric rod 43, and the small pinion 41, are shown in Fig. 246.

A front view of the shuttle race 39¹ appears in Fig. 248, and when the shuttle frame and shuttle are placed in the race, the cap, Fig. 249, is placed in front, and secured by means of the spring 50, Fig. 250, and the screw shown detached. The short shaft 47, Figs. 246 and 251, which carries the pinion 41, passes through the central hole in the shuttle race 39¹, Fig. 248, and is naturally free to rotate in the said race. Fixed to this short shaft 47 is the shuttle driver, Fig. 251, and this driver is provided with two blunt projecting ends 48 and 49 which rest against the corresponding recesses 48¹ and 49¹ in the shuttle frame 51, illustrated in the upper view in Fig. 252. The position of the shuttle 45 is shown dotted in the shuttle frame 51. It will be evident that as the shaft B, Figs. 244 and 245, rotates, the eccentric rod 42 will cause the rack 43¹, at the upper end of the eccentric rod 43, to rotate the pinion 41 and the short shaft 47, and also the shuttle driver, Fig. 251, alternately clockwise and counter-clockwise; hence it follows that the drivers 48 and 49 will cause the shuttle frame 51, Fig. 252, to make similar oscillatory movements inside the shuttle race 39¹, Fig. 243. Two views of a spool 46 are shown in Fig. 252, and this spool carries the lower stitching thread 52.

The lower sewing mechanism is illustrated completely in Figs. 253 to 256 inclusive. Fig. 253 shows the needle 10 through the tapes and card 44. The upper sewing thread 22 passes down the long groove side of the needle—the side nearest the thread take-up lever—out at the short groove side, and then to the stitched portion of the tapes and card. When the

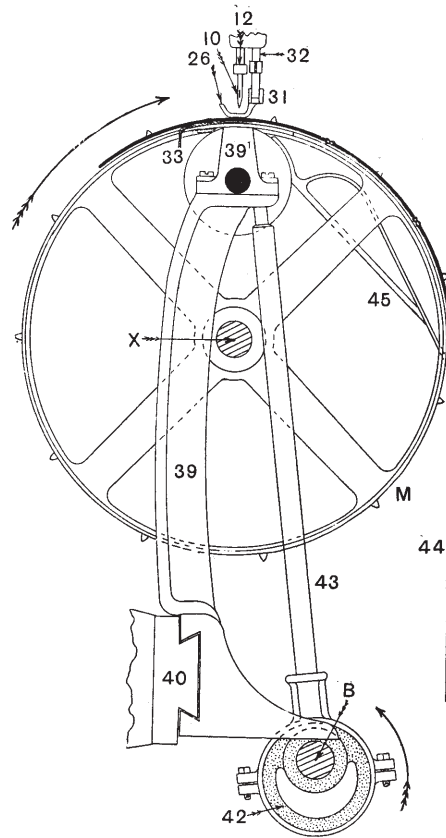
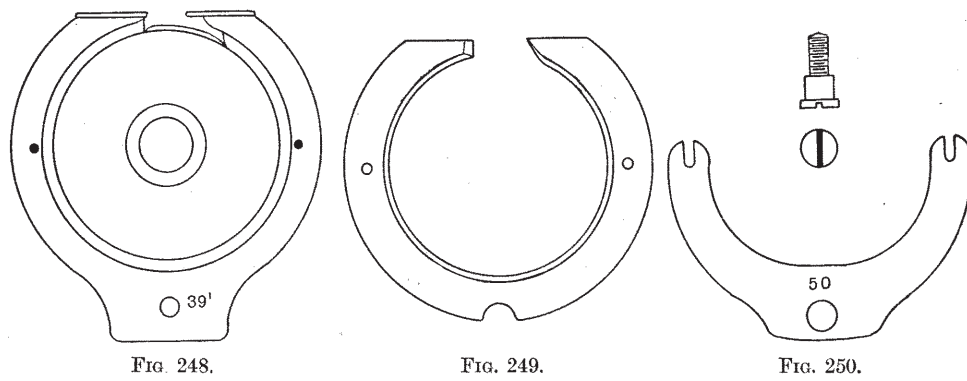
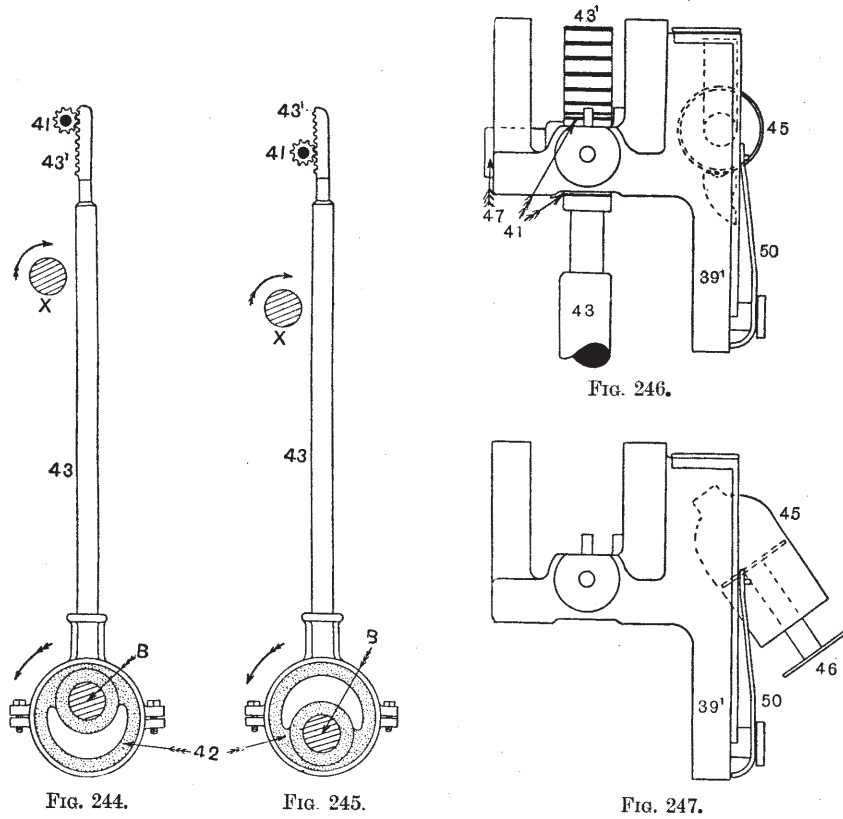

Fig. 243.

needle reaches the lowest position it is caused to rise about $\frac{3}{32}$ in. in order



to form a loop for the point 54 of the shuttle frame to enter. The point 54 is shown entering the loop in Fig. 253, although the needle eye is

illustrated in a lower position than what actually obtains in practice, so that the loop might be seen more clearly. The needle eye is only about $\frac{1}{8}$ in. below the point 54 when the latter enters the loop. The point 48 of the shuttle driver will at this moment be pushing the shuttle frame round

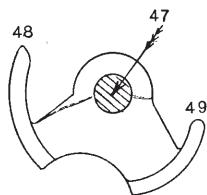

FIG. 251.

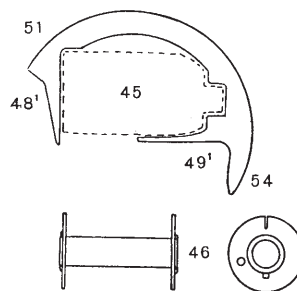

FIG. 252.

clockwise, Fig. 253, and simultaneously with this movement the needle rises. In Fig. 254, which is a plan of Fig. 253 minus the shuttle 45, the point 54 is shown behind the needle 10 and in the loop formed by the thread 22 and the needle.

In Fig. 255 the needle is nearly at its highest point, and the shuttle 45

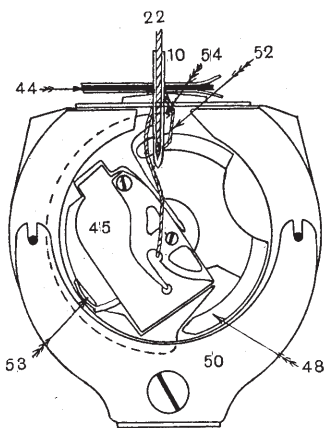

FIG. 253.

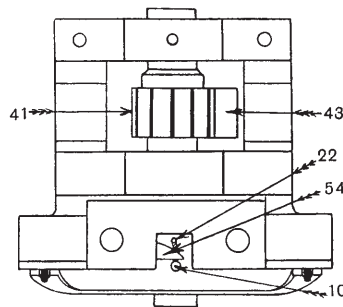

FIG. 254.

is approaching the extent of its travel clockwise. In this view the needle thread 22 is shown with the loop much enlarged—the thread take-up lever having let off sufficient to allow the body of the shuttle to pass through and to carry its own thread 52 with it.

In Fig. 256 the shuttle has arrived at the end of its journey, the needle is full up, and the thread take-up lever is drawing the slack of thread 22

with it ; this operation causes the large loop to slip over the back of the

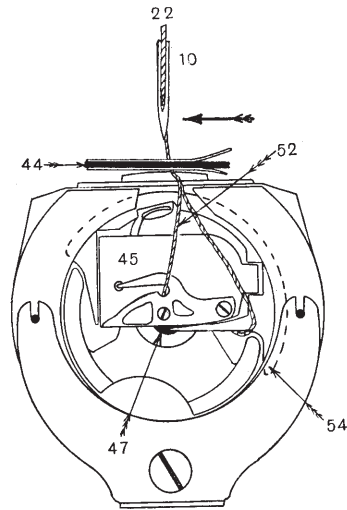

FIG. 255.

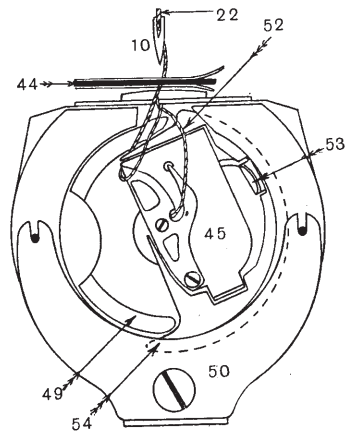

FIG. 256.

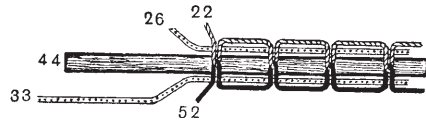

FIG. 257.

shuttle somewhat as indicated. The thread 22 has to be drawn sufficiently tight to enable it to occupy a position near the middle of the card—that is, midway between the top and bottom tapes.

The feed dog starts and completes its motion just before the needle enters the cloth to repeat the cycle of operations.

Fig. 257 is an enlarged view of the tapes, card, and sewing threads, with a more or less diagrammatic view of how the two threads should appear when the stitching is completed. The upper view in Fig. 258 shows the presser foot 31 and the needle plate 37, together with an enlarged view of the needle 10, the card 44, and the two tapes 26 and 33. The lower view is a plan of part of the needle plate 37, and this shows clearly how the lower tape 33 is threaded in the slots of the needle plate.

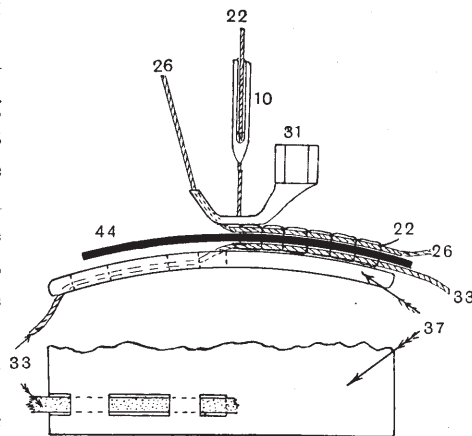
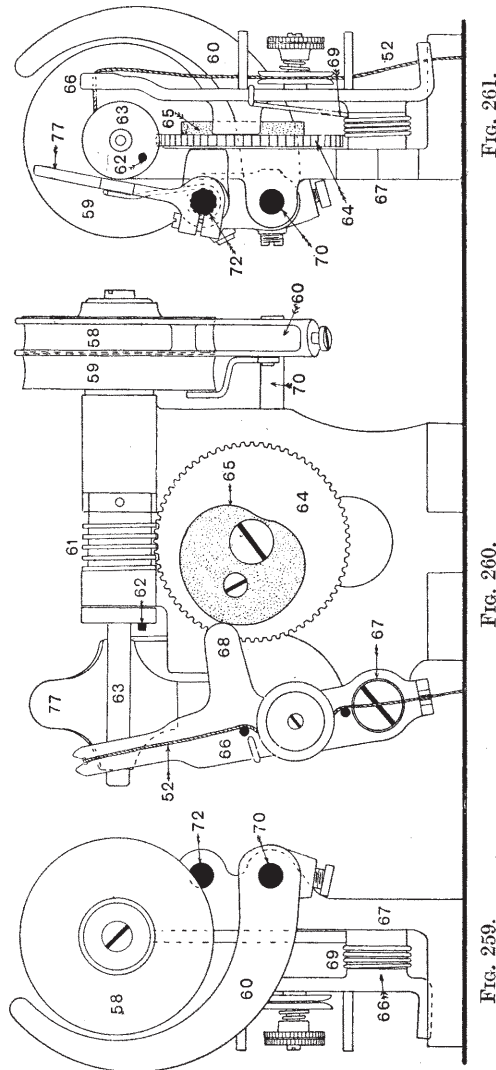

FIG. 258.

Returning now to Figs. 238 and 242, it will be seen that a crossed round belt 55, on the grooved wheel 21, communicates the rotary motion to the double-grooved pulley 56 on the stud 56¹, while a similar round belt 57 passes from the larger groove of wheel 56 to the pulley 58 of the spool, and through this to the spool-winding mechanism.

Several views of the spool-winding mechanism, which are shown about $\frac{3}{8}$ ths of their actual size, are illustrated in Figs. 259 to 266. Fig. 259 is an elevation of the driving end; Fig. 260 is an elevation of the front of the winder; Fig. 261 is an elevation of the opposite end to the driving end; Figs. 262, 263, and 264 are elevations to illustrate the automatic knock-off motion; Figs. 265 and 266 are plans.

The round belt 37, Fig. 242, when inoperative, is naturally on the loose pulley 58, Figs. 259 to 266, but may be pushed on to the fast pulley 59, when desired, by means of the belt fork 60, and this may be done while the stitching machine is in operation. The belt fork is opposite the loose pulley in Figs. 260, 263, and 266, and opposite the fast pulley in Figs. 262 and 265. The shaft of the two pulleys is provided with a worm 61, a pin 62 for rotating the spool, and a spool spindle 63. Hence, when the belt is pushed on to the fast pulley as shown in Figs. 262 and 265, the spindle 63 and the spool 51 will be rotated. At the same time the worm 61, Fig. 260, will move the worm-wheel 64 slowly round, and also the heart-shaped cam 65, which is secured to the wheel 64, as shown.



The yarn guide 66 is fulcrumed at 67, while the projecting arm 68 is kept in contact with the heart-shaped cam 65 by a spiral spring 69, Fig. 260. The sewing thread 52, exaggerated in thickness, will thus be carried

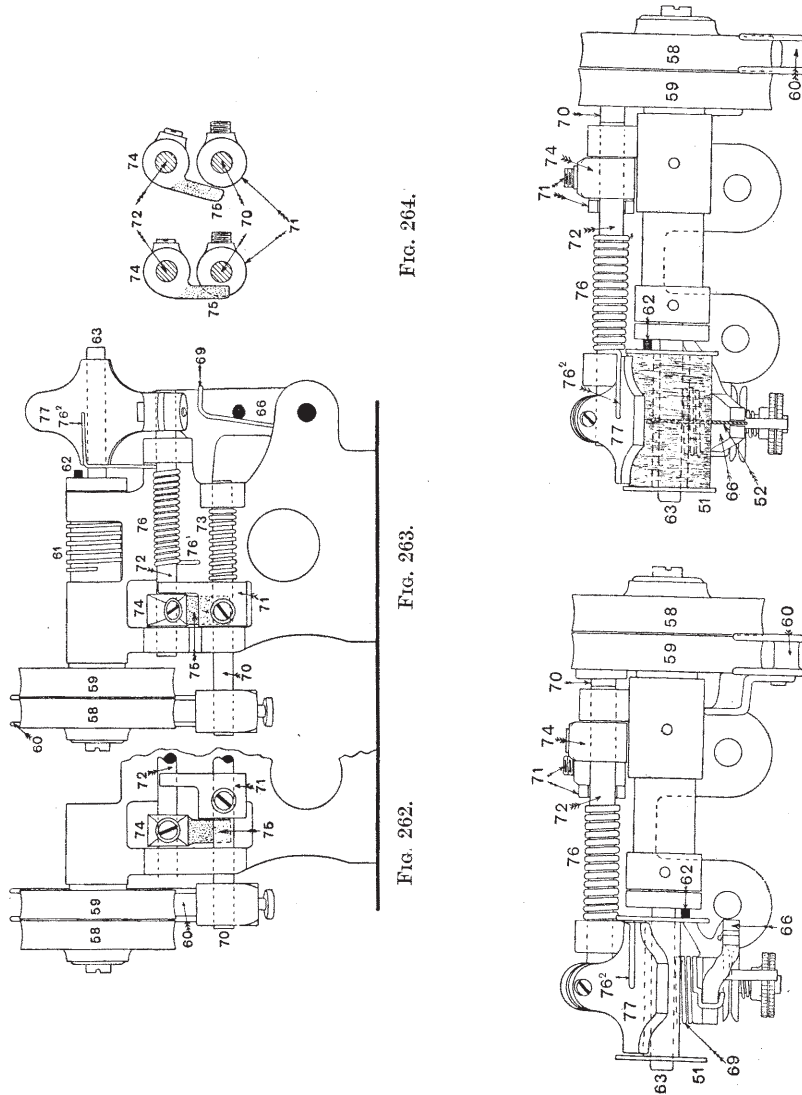

slowly and at a uniform speed backwards and forwards, between the two flanges of the spool 51, Figs. 265 and 266. This work is done, as already mentioned, during the time that the cards are being stitched by the machine proper. All the attendant has to do is to see that there are cards on the

pegs of the wheel M, Fig. 242, place an empty spool on the spindle 63, Figs. 259 to 266, and start the winding apparatus by pushing the belt fork 60 in the proper direction; the apparatus is stopped automatically when the spool is filled. This will be understood by consulting Figs. 262 to 266. Fixed to the belt fork rod 70 is a bracket 71, the projecting arm of which is forked, as shown in Figs. 265 and 266, to receive the stop-rod 72—the forked end of bracket 71 is omitted in Fig. 264. A spiral spring 73 encircles the rod 70, and this spring will clearly be compressed when the belt fork 60 and its rod 70 are pushed to the right in Fig. 262, or to the left in Fig. 265; the spring is of course not visible in the latter view, since it occupies a position under the spring 76.

A further bracket 74 is secured to the rod 72, and this bracket has an arm 75, stippled in Figs. 262 and 264, which depends as shown. Around the rod 72 is the above-mentioned spring 76, but this spring is arranged not to be compressed, but to cause a partial rotation of the rod 72 when the spool is full.

It will be seen in Fig. 263 that one end of the spring is against the framework at 76¹, while the other end 76² is behind the feeler 77, and the force of the spring tends to keep the feeler 77 in close contact with the empty

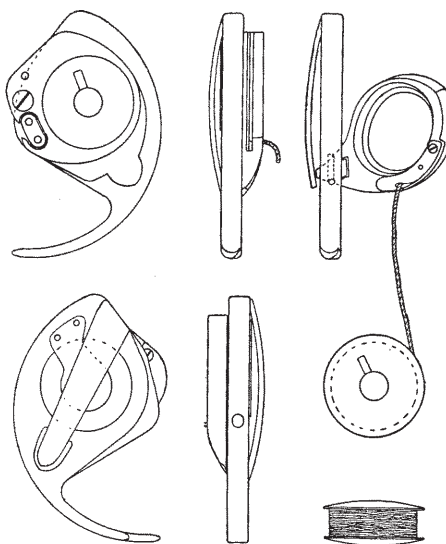

FIG. 267.

spool 51, Fig. 265, and also with the partially filled spool. When the belt fork 60 and its rod 70 are pushed to the right in Fig. 262, or to the left in Fig. 265, the projecting arm 75 slips, or is, rather, forced, in front of the boss 71 (see Figs. 262 and 264), and thus keeps the belt fork in the on position. As layer upon layer of sewing thread 52 is wound upon the spool 51, the feeler 77 is forced outwards gradually, but very slowly. Ultimately, when the spool is full, as in Fig. 266, the feeler 77 is full out, and the rod 72 will thus have been partially rotated until the arm 75 (see the right-hand view in Fig. 264) is clear of the bracket 71. When this happens it is obvious that the spring 73 will exert its potential energy on the bracket 71, and will force it, and also the belt fork 60, to the off position, as exemplified in Figs. 263 and 266. Again, the mechanism

being very small—see the complete apparatus in Figs. 238 and 242 as compared with the machine—it is necessary to set the automatic motion carefully, and when thus set it performs its work in an elegant manner.

Fig. 267 illustrates several views of a different kind of shuttle frame, shuttle, and spool—a type which although not modern is still in use in a number of jacquard card-stitching machines.

A few of the desirable conditions in connection with cards and card lacing are enumerated in Table X.

TABLE X.

1. A quick method of lacing.
2. Level, strong, and comparatively inelastic lacing material, and for machine lacing, freedom from knots or thick places.
3. Substantial cards capable of withstanding the drag, and the usual wear and tear which obtains while the cards are in operation on the loom.
4. Cards which are capable of resisting changes of shape and size under various atmospheric conditions.
5. Facilities for introducing new cards into the chain to replace broken ones from any cause.
6. Conditions which tend to prolong the life of the cards.
7. Lacing or stitching material which will allow each card to lie very close to the face of the cylinder when the selection of needles and hooks is taking place.
8. The prevention of card sliding near to the place where a card is removed, or where the lacing twine breaks.
9. Rapid methods of making the necessary changes for different sizes of cards, and for different numbers of stitches per card.
10. The simplest possible type of mechanism, taking into consideration the work which has to be performed.
11. Mechanism which does not easily get out of order, and in which those parts subjected to excessive work are accurately made and have wear-resisting qualities.

Some of these conditions have already been discussed ; others do not come within the scope of this work. With careful work and lacing machines in good working order a set of cards may last for a considerable time, and may be in a moderately good condition when the lacing twine is worn out or ready for renewing. Some sets of cards may remain in good order for two or three renewals of lacing. In other cases the cards quickly begin to wear out, breaking near the edge, and thus causing a considerable amount of loom stoppages, with a consequent loss of production.

Fig. 268 has been prepared partly to illustrate different kinds of lacing and stitching, and partly to enable us to refer to conditions which might prove useful in cases where breaking of cards is common. The particulars referring to Fig. 268 are in Table XI.

TABLE XI.

No. 1.	Face of cards for Brussels jacquard.
„ 2.	Back „ „ „ (Laced on Singer's lacing machine.)
„ 3.	Face of cards for 600's jacquard.
„ 4.	Back „ „ „ (Laced on Parkinson's "Rapid" machine.)
„ 5.	400's cards laced on hand frame.
„ 6.	600's cards with double twist between cards and no lace holes. Woodhouse and Scott's improved method.
„ 7.	400's cards tape stitching. Singer's stitching machine.

Nos. 1 to 5 are laced with one black twine and one white twine, but a lens is necessary to distinguish them.

The lace holes in Nos. 3, 4, and 5—that is, in the cards for 600's and 400's jacquards—are at reasonable distances from the edges of the card, and hence these distances afford a moderate resistance to card rupture. In some cases the holes for the 600's cards, instead of being in the 2nd and 11th rows as indicated in Nos. 3 and 4, are in the 3rd and 10th rows, thus increasing the distance from the two edges, and proportionately strengthening the outer sections. In Nos. 1 and 2, however, where four lace holes are used, the outer holes are very near the edges of the card, and it is a very common occurrence for the card to break at these parts.

In Nos. 6 and 7 no lacing holes are required. No. 7 is, as stated, the stitched card, where the ordinary sewing cotton is passed through the card, and through narrow tapes, one on each side of the card, approximately every $\frac{1}{4}$ in. When the cards require to be re-sewn, and the needles pass through the same holes during the re-sewing, the cards are practically as strong as they were when sewn for the first time. If, however, through any defect, the needles enter fresh parts of the card and near the old holes, it is not unusual for the sewn portion to break off, in which case the card is useless. This defect, which was more or less pronounced when the peg wheel was under the influence of a brake, is now practically eliminated in the modern machine, where the peg-wheel, as already illustrated, is driven by a pawl and a ratchet-wheel. In No. 6 type semi-circular holes are cut out of the edge of the card, and two pairs of thin lacing twine are rotated in opposite directions to make a crossing more secure than that obtained by a single pair of lacing twines.

Each method of lacing has its own particular advantages, and also its drawbacks. It is evident, however, that there can be no sliding in the stitched cards illustrated at No. 7, and that each card can get very close to the face of the cylinder. Moreover, if a card break, it can easily be replaced by removing the stitching, making a half-twist of the two lengths

of tape, and inserting the new card between ; this may be done without removing any of the undamaged cards from the loom. In some cases it may be necessary to insert a few stitches by hand. A somewhat similar method of repairing is possible when cards are laced as illustrated in No. 6,

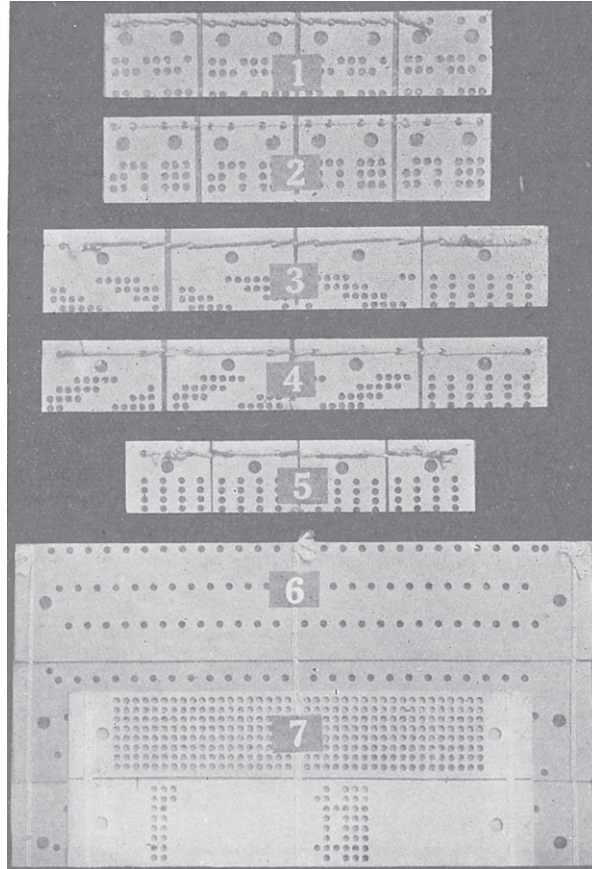

FIG. 268.

but in this, as well as in the case of all other systems of lacing, there is a tendency for the cards to slide.

The foregoing equipment of card-cutting, card-lacing, and card-stitching machinery is quite sufficient for small factories, or for those factories in which there is little concurrent duplication of the same patterns, for it is quite clear that whether the jacquard machines are of the ordinary-pitch, medium-pitch, or fine-pitch type, all the essential operations for

the preparation of the jacquard cards ready for the loom can be efficiently performed by one or other group of machines already described.

When, however, conditions arise which necessitate the employment of two or more looms on the same design, a condition which is very common in some industries, it is desirable that a further group of machines should be introduced in order that duplicate sets of cards may be prepared more quickly than is possible by the ordinary card-cutting machine. The operation of lacing or stitching the cards will still be performed at precisely the same speed as if the cards had been cut in the ordinary way on the piano card-cutting machine.

This auxiliary mechanism usually consists of two essentially different machines, termed respectively "peg-and-lace-hole machines" and "repeating machines." The former, as its name suggests, punches the holes for the pegs and for the lacing twine only, and in otherwise perfectly plain or uncut cards, in order that these cards may be laced or stitched by one or other of the methods already described preparatory to being introduced into the repeating machine where the actual holes for the pattern are punched. The girl in the foreground in Fig. 127 is lacing (stitching) a set of cards which have been prepared in a peg-and lace-hole machine ready for duplication in a repeating machine. The process of repeating may be, and is, performed by a method entirely different from that which we purpose describing at present; the method to be described first is, however, the more efficient, although the other machine possesses its own particular advantages, which will be discussed at the proper time and place.

CHAPTER XV

PEG- AND LACE-HOLE MACHINES

A LITHOGRAPHIC view of the peg- and lace-hole machine made by Messrs. Devoge and Co., Manchester, appears in Fig. 269. The machine is small,

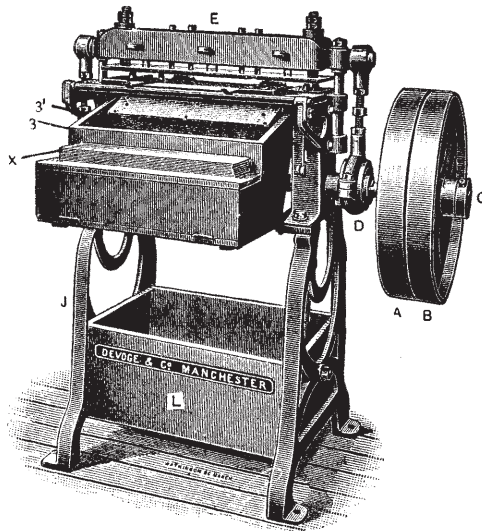

FIG. 269.

and in the illustration looks very simple, but, nevertheless, it performs the work admirably, and is an essential adjunct to the more elaborate machine by means of which the actual holes in the cards for the pattern are punched.

The illustration in Fig. 269 shows quite clearly the fast and loose pulleys A and B on the main shaft C, the strap of the eccentrics D, and the rod which connects the strap of the eccentric with the end of the punching block E at the top of the machine. It also shows a

pile of uncut cards X on the shelf of the upper wooden box 3, a card immediately under the punches of the upper punching block E, and a punched card emerging from the machine and about to drop into the open part 3' of the upper wooden box. The three rows of lacing holes and the two peg holes are distinctly visible in the latter card, and the punching of these holes, as already stated, constitutes the sole function of the machine. The large box L near the floor is placed there to catch all the small circular bits which are punched out of the cards, and which drop from the corresponding punch holes in the bottom punching plate.

Fig. 270 is an elevation of the driving end of the machine, but for clearness the fast and loose pulleys have been omitted ; their positions and

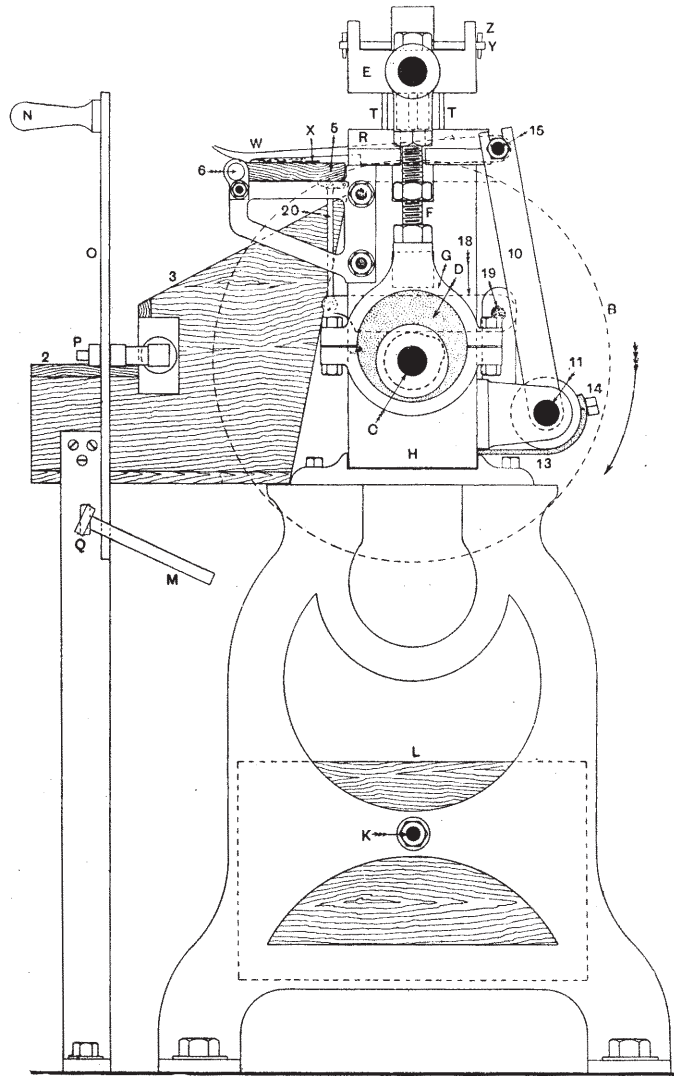

FIG. 270.

size are represented by the dotted circle marked B. A front elevation is shown in Fig. 271, while a plan view is displayed in Fig. 272. The main shaft C carries the eccentrics D, Fig. 270, one near each end, and the adjustable rods F connect the straps G of the eccentrics D to the ends of

the rising and falling block E. The upper framework H is supported by the side frames J, and the latter are joined by a rod K which passes through the box L into which the punched-out discs of the cards drop.

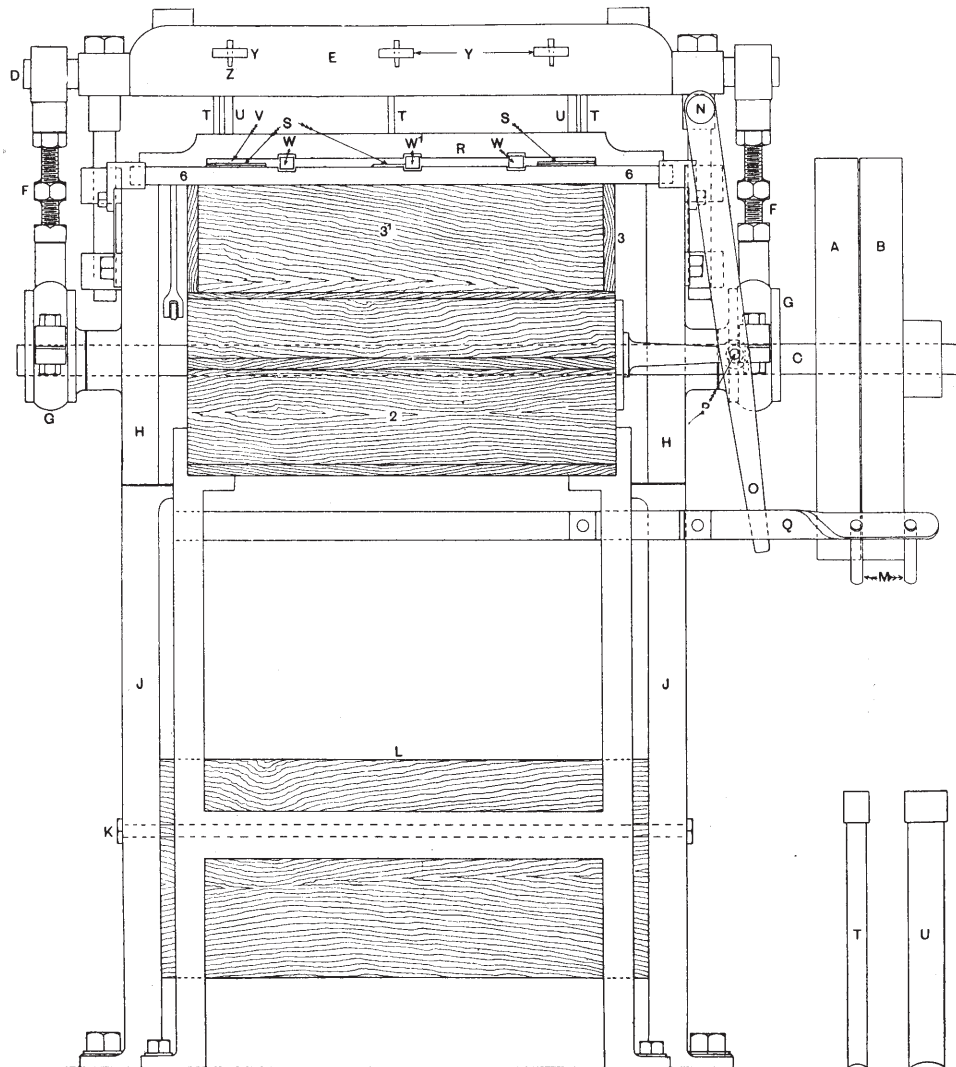

FIG. 271.

The machine illustrated in Figs. 270 to 272 is arranged to be driven from a drum on a shaft below the floor, and the belt fork M shows that the direction of movement is clockwise as indicated by the arrow in

Fig. 270. The belt fork M is operated by the handle N near the top of the lever O fulcrumed at P, the lower end of the lever passing through a slot in the sliding bracket Q to which the belt fork M is fixed as depicted in Fig. 271. The machine can, of course, be driven from above if desired, and necessary parts for this purpose are provided.

It is obvious from Figs. 270 and 271 that as the main shaft C rotates, the eccentrics D with their straps G and rods F will cause the punching block E to rise and fall every revolution; the throw or stroke of the eccentric D, and therefore of the punching block E, is $1\frac{1}{4}$ in. The actual punching plate or guide plate is composed of two fixed plates R and S; the former

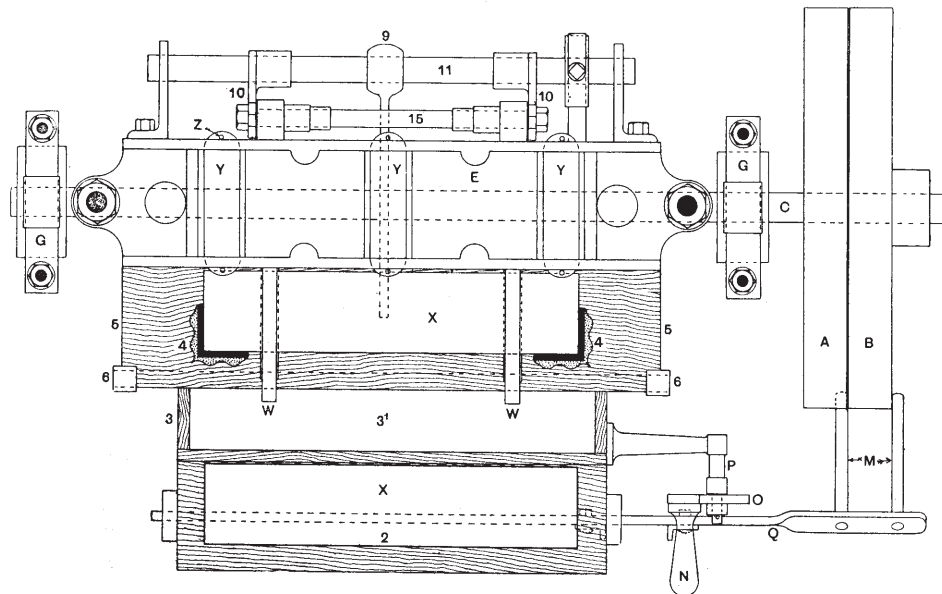

FIG. 272.

in conjunction with the block E keeps the punches vertical and guides them to the holes of the actual cutting plate S; whereas the upper punching block E supports the punches and imparts the pressure which causes the said punches to pass through the card.

When the block E is in the highest position as indicated in Figs. 270 and 271, the lower and cutting parts of the punches T for the lace holes and U for the peg holes are raised into the guide plate R and above the slot V by means of shoulders near the upper ends of the punches. This will be understood from the much-enlarged detached view of the punches in Fig. 271, and from the sectional views to follow. It is at this time that the recently punched card is ejected, and a new card inserted. The hook

W, Fig. 270, is ready to draw the card X between the two fixed guide and cutting plates R and S, and this must obviously be accomplished before the ends of the punches T and U reach the card as the block E is descending. The cross-plates Y, Figs. 271 and 272, are secured to the block E by passing their ends through slots in the block and inserting pins Z as shown, so that when the block E descends, the cross-plates Y force down all punches T and U, and effect the cutting of the eight holes as exemplified in Fig. 269. The arrangement also offers facilities for the quick removal or entry of punches before and after repairs, or to place the punches in different positions with regard to the size of card which is in work.

The stock of cards X, Figs. 269 and 272, rests upon the ledge 2 of the

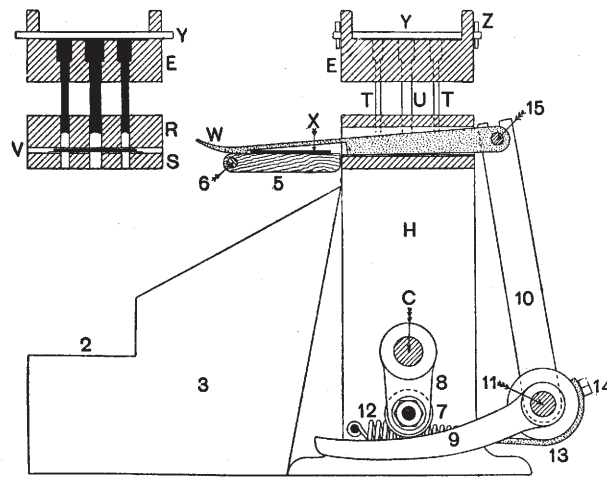

FIG. 273.

upper box 3, the opening 3¹ of the latter being left white in Fig. 272. As soon as the hooks W have drawn forward the card X, Fig. 270, under the punches T and U, the attendant takes another card from the pile and places it in position between the angular guide plates 4, Fig. 272, of the lifting board 5, fulcrumed at 6, so that the card will be as illustrated before the hooks W come forward. In Fig. 272 the hooks are forward—that is, full out, and their drawing edges overlap the outer edge of the card.

The various operations will be better understood by reference to the sectional views in Figs. 273, 274 and 275. In Fig. 273 the hook W is full out, and has been forced to this position by the action of the anti-friction bowl 7 on the end of the lever 8 fulcrumed near the middle of shaft C, and the two levers 9 and 10 fulcrumed on the shaft 11. A spring 12, one end of which is fixed to a pin projecting from a convenient part of the frame,

and the other end to a strap 13 attached by a set-screw 14 to the boss of the lever 9, serves to draw the levers 9 and 10, and therefore the hooks W, to their other extreme positions. Thus, as the shaft C and the crank 8 move clockwise in Fig. 273, the anti-friction bowl 7 gradually allows the lever 9 to be drawn upwards by the spring 12 and the connections mentioned, and therefore the catch on the hook W will draw the card X to the position indicated in Fig. 274. Small angular stop-pieces, not shown in the illustrations, are inserted at the back to arrest the card X when it has reached its proper position with regard to the punches T and U; one set of stop-pieces are used for 600's cards, and a different set for 400's cards. The front punches remain for all sizes of cards, but the peg-hole punches and

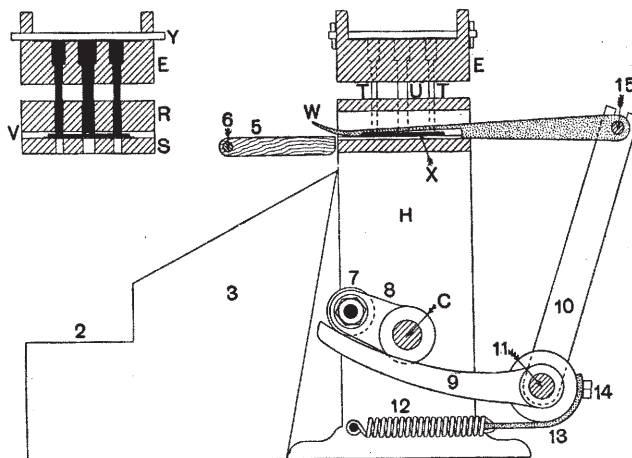

FIG. 274.

the back row of lace-hole punches are moved to suit the different widths of cards.

When it is required to punch the necessary lace and peg holes for shorter cards, say those for 8-row 200's jacquard machines, one only of the two hooks W is required, but an additional hook W¹, Fig. 271, is brought into use. The boss end of this hook is made in halves so that it may be quickly clamped on to the rod 15, Figs. 270 and 272, to which the hooks W are attached, and as quickly removed when longer cards of the 400's and 600's kinds are to be treated.

The punches T and U enter the card X immediately after the latter has been placed in position as indicated in Fig. 274 and by the sectional view on the left. It should be mentioned that the slot V into which the card is drawn is about $\frac{1}{8}$ in. deep, but the entrance is curved to about $\frac{3}{8}$ in. in order to admit of an easy and sure entrance of the card. When the

eccentric D, and therefore the block E, are full down, the punches T and U have passed through the card and have penetrated about $\frac{1}{8}$ in. into the holes in the cutting plate S. A clearing plate—that is, a plate operated by springs when the block E is rising—to remove the card from the ends of the punches T and U is illustrated in Fig. 269, but in the more modern machine this plate is unnecessary.

As the shaft C rotates, the block E is raised and the punches T and U are withdrawn from the card enclosed in the $\frac{1}{8}$ in. gap V, and when all the punches are clear, and the anti-friction bowl 7 has been rotated to the

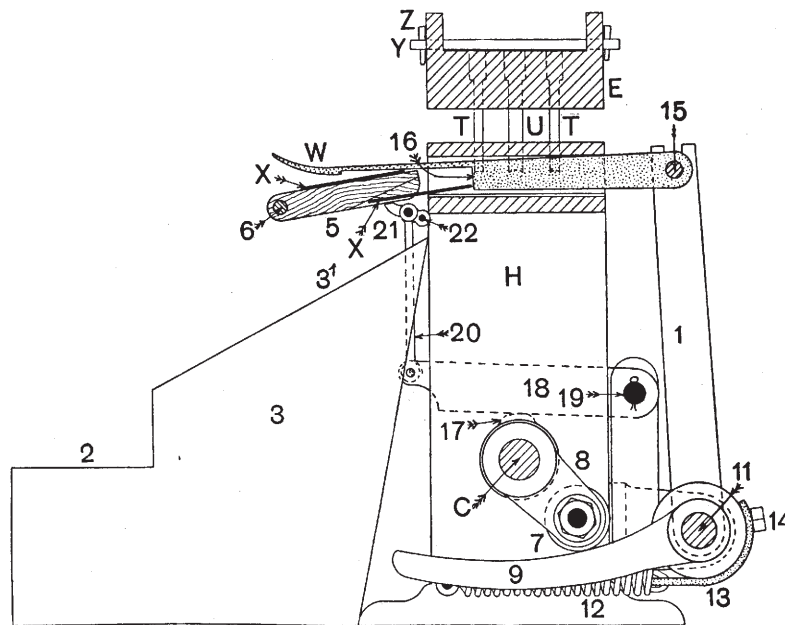

FIG. 275.

point indicated in Fig. 275, the hook W will have been forced outwards to the position shown. During this outward movement it is necessary that the newly punched card shall be ejected in order to leave room for the entrance of a new card as the hook W returns. A deep shoulder 16 on each of the two hooks W forces the card X from the gap V, and at the same time a small cam 17 on the shaft C raises the lever 18 fulcrumed at 19. The outer end of this lever is attached to the lower end of the rod 20, while the upper end of the rod is attached to the short lever 21 fulcrumed at 22. It will thus be seen that the outer end of the lever 21 will act upon the underside of the lifting board 5 fulcrumed at 6, and will raise the free end sufficiently high to form a gap through which the card X may pass and

then drop into the opening 3¹ of the box 3. The underside of the lifting board 5 is cut away to facilitate this action.

Without stating the actual times when the various actions take place, we may indicate them generally as follows: Just before the eccentric D reaches the top centre, the hooks W have slipped over the card on the top of the lifting board 5. Then the lifting board drops to its lowest position, and the hooks W commence to move in, drawing the card X with them. The eccentric causes the block E to move down when the card has travelled about $1\frac{1}{2}$ in. When the card is full in—*i.e.* under the punches T and U with the hooks W full in—the upper block E is about $\frac{1}{4}$ in. from the lowest position. The eccentric is on the front centre when the lifting board 5 commences to rise, and shortly after the edge of the lifting board raises the hooks, and the latter commence to move outwards and to eject the newly punched card as described.

Another efficient peg- and lace-hole machine is that illustrated in Figs. 276 to 283. This machine was made originally by Messrs. William Ayrton and Co., Gorebrook Iron-works, Manchester, but it

is now made by some other firm. A lithographic reproduction which illustrates the general appearance of the machine appears in Fig. 276. This view represents the feed side and the balance-wheel end of the machine; the cards which are ready to be fed are shown on the wooden tray at the top of the framework and the upper plate, while those which have been punched and delivered from the machine are at the delivery side. The opening between two of the upper arms of the balance-wheel enables one to see the ends of the cards.

This general view might be consulted with the description of the line

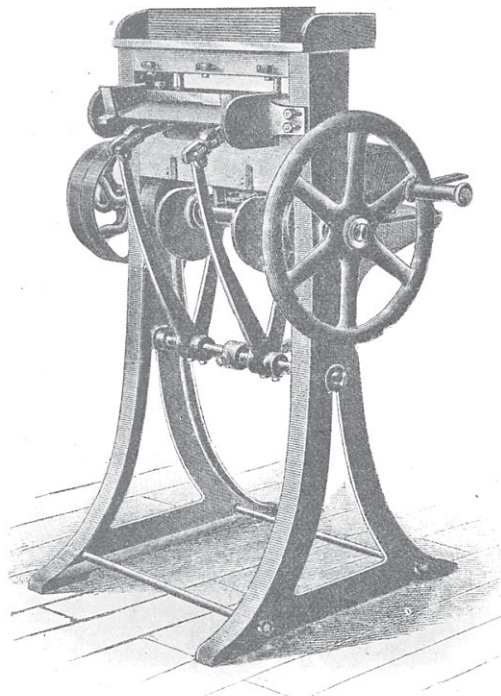

FIG. 276.

drawings, of which Fig. 277 is an elevation of the driving end, Fig. 278 is a front elevation of the feed side, and Fig. 279 is a plan. The machine may be driven either by hand or by power; the illustrations show the power-driven one, in which the fast and loose pulleys A and B are on the

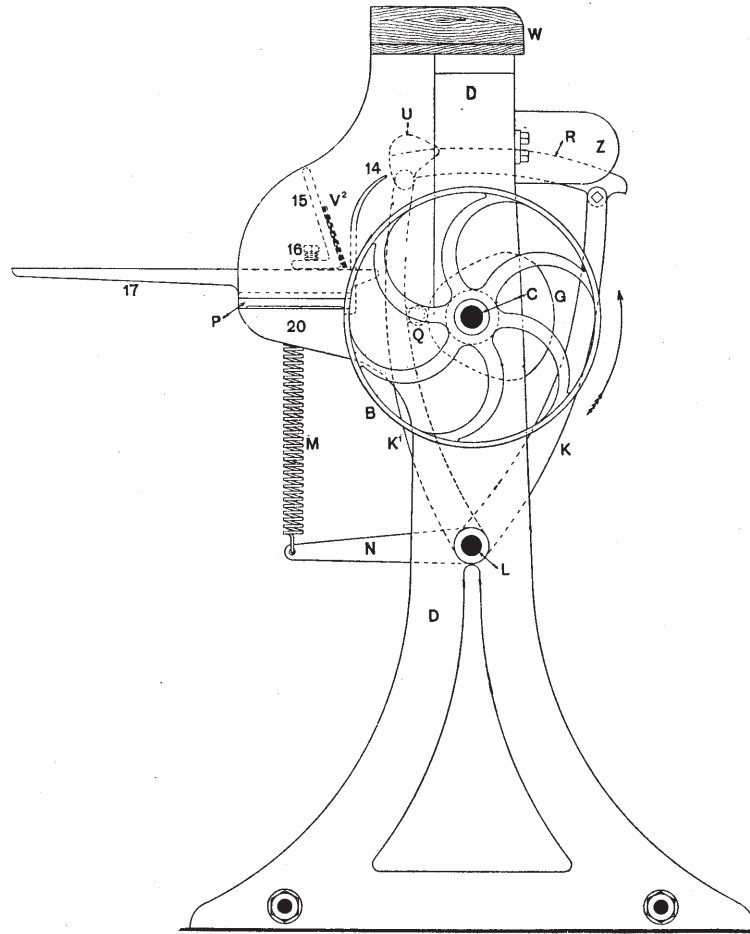

FIG. 277.

main shaft C. The latter extends through the machine, is supported in the usual manner by the two side frames D, and carries a balance- or hand-wheel E at the end opposite to the driving end. Between the two side frames D, and fixed to the main shaft C, are two eccentrics F, Fig. 278, and two cams G. The two eccentrics F, Figs. 278 and 282, raise the punching block H through the medium of two anti-friction wheels J,

and restrain its downward movement, while the two cams G operate in one direction the card-carrier arms K and K¹, both of which are fulcrumed on the low shaft L. A spring M, one end attached to the free extremity of rod N, fulcrumed on L, and the other end to a web O (also shown in Fig. 282) in the bracket P, serves to return the arms K and K¹ to the

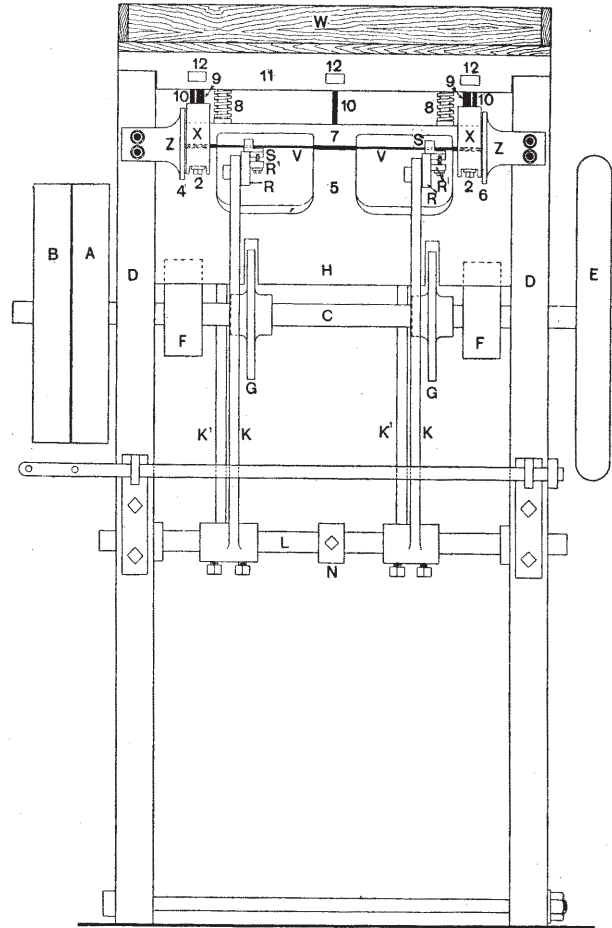

FIG. 278.

position illustrated in Fig. 277. The arm K¹ carries a wing upon the pin of which is placed an anti-friction roller Q, and it will be seen that as the shaft C rotates, the cams G will gradually force the anti-friction rollers Q—one on each arm K¹—and the two pairs of arms K and K¹ to the left in Fig. 277, and in Figs. 280 to 282. The three latter views illustrate sections of parts of the machine.

The gaps between the upper ends of the two pairs of arms K and K¹ (see also Fig. 276) are bridged by the actual card carriers R, provision being made in the latter for two cards, and somewhat as exemplified in Figs. 280 to 282. Two adjustable brackets are placed on each card carrier R, the object of these being to provide accommodation for cards of different widths, say the usual 400's, 500's and 600's jacquard cards. These adjustable guides S are shown diagrammatically in Figs. 280 to 282, but the method of adjustment is shown only in one of each pair in the plan view, Fig. 279. The lock-nuts and screw T, in conjunction with the lug R¹ on the card carrier R, and similar parts a little farther on the latter, but not illustrated in the figure, enable the attendant to move the guides S on the same card carrier R nearer to or farther from each other, and thus accommodate cards of various widths. On the upper end of each arm K¹ is a plate U, Fig. 277, the upper end of which projects above the surface of the card carrier R as shown.

The cards V, as already mentioned, are placed in the wooden tray W, Fig. 278, on the top of the machine with the numbers of the cards on the left-hand side of the card. In many cases the numbering is left until the lacing operation, or at least until the peg- and lace-holes have been cut; when this is adopted—and it is probably the best way for many reasons—it is a common practice to apply a strip of paint on the long edges of the cards and near to the end which will ultimately receive the numbers, so that the correct position of the cards will be maintained during the operation of lacing. An extra punch in the machine to cut a recess near the end of each card, or a small bit removed when the cards are being made, will answer the same purpose.

As the operation of punching proceeds, the cards are taken singly and successively from the pile and placed with the ends of the card resting on the bases of the two fixed guides X, and the middle of the card resting on the support Y, Figs. 278 and 279. The two guides Z, which are fixed to the two side frames D as shown, fix the lateral position of the card. The fixed guides X are provided with adjustable parts for different widths of cards, and when these parts are placed in their proper positions they are secured there by the set-screws 2, Fig. 278.

The card may be placed in the fixed guides X and Z, Fig. 278, at any convenient time, but it is usually placed there when the arms K and K¹ are in or nearing the extreme right-hand position, Figs. 277, 278, 279, 281 and 282. If the card is entered when the arms K and K¹ are on the extreme right, it will drop into both the fixed guides X, and into the guide 3 of the card carrier R; but if it is entered before this time it will drop only into the fixed guides X, and as the arms K approach the extreme outward position, the inclined portion of the guides S will slip under the

card, and ultimately allow the latter to drop over the inner edge of the guide S and into its correct position in the guide 3.

During the time that the shaft C and the cam G move from the position illustrated in Fig. 281 to that in Fig. 280, the arms K and K¹ and the card carrier R will move from the extreme right-hand position to the extreme left-hand position. And just before this movement is completed the eccentrics F, Figs. 278, will commence to raise the punching block H,

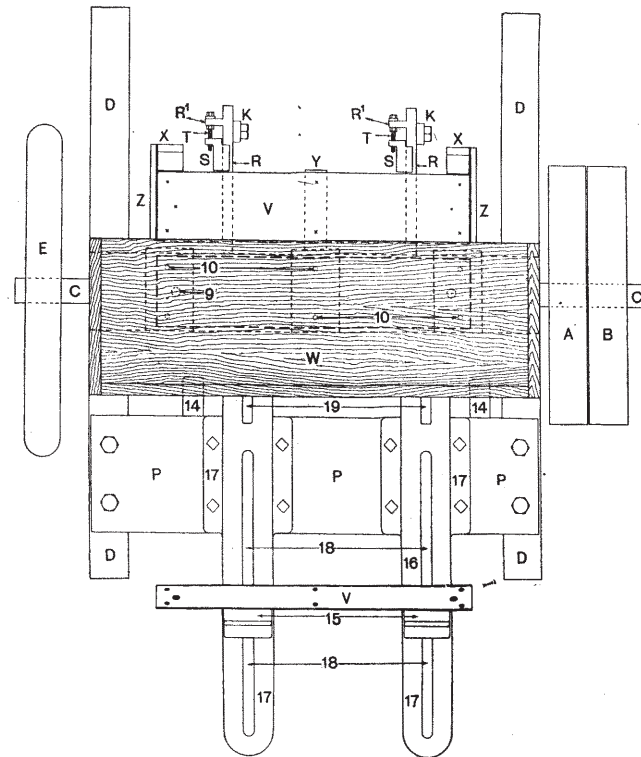

FIG. 279.

and the card in the guide 3 will then, of course, be in the position for being punched as shown in Fig. 280.

The three sections 4, 5, and 6 of the block H, Fig. 278, raise the card until the latter comes into contact with the clearing plate 7, the lower surfaces of which coincide with the upper surfaces of the three sections 4, 5, and 6 of the block H; the further upward movement of the block H carries the clearing plate 7 with it, and the latter therefore compresses the two springs 8 which encircle the pins attached to the clearing plate. The card carriers R move to and fro in the gaps between 4 and 5 and

between 5 and 6. The peg-hole punches 9 and the lace-hole punches 10 have the usual-shaped heads as shown in Fig. 282, and are supported by the upper plate 11, while three bars 12 pass through slots in the plate 11 and cover the heads of the three rows of punches 9 and 10.

Now, when the block H is in the highest position all the peg- and lace-holes punches will have passed through the card V as indicated in Figs. 281 and 282, and when the block commences to descend, the card carriers R will have moved back to the original position indicated also in Fig. 281, with the card V immediately over the inner guide 13. At a certain time—indicated in a table to follow—the punching block H shows

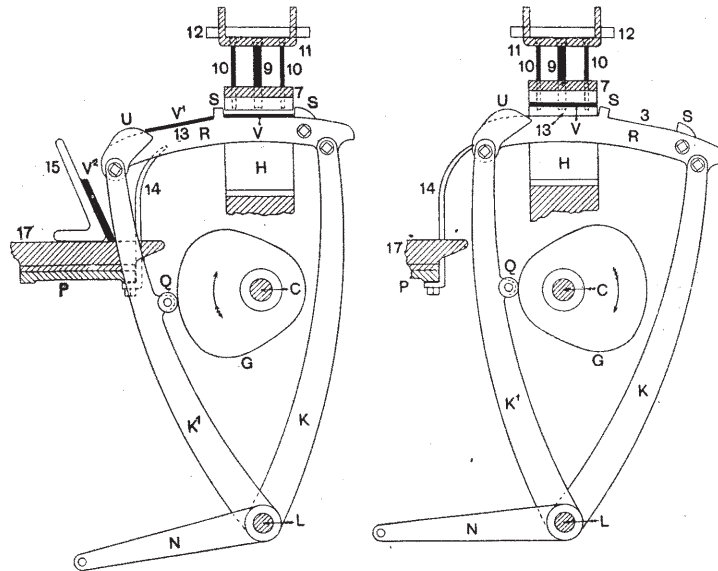

FIG. 280.

FIG. 281.

a tendency to leave the clearing plate 7; at this time, or immediately after, the compressed springs 8 force the clearing plate 7 downwards, and thus the latter pushes the card from the ends of the punches 9 and 10 into the inner guide 13. It is about this time that another card will be placed in the outer guide 3, after which the card carrier R will move forward again to the position indicated in Fig. 280, and there will then evidently be a card in each guide 3 and 13.

The punched card in guide 13 is removed from the guide and the carrier R in a unique yet simple manner. The operation is illustrated in Fig. 282. From what has been said it will be gathered that after the block H rises and the two cards are in the positions indicated in Fig. 280, the right-hand card will be carried upwards by the block H, and will remain on the ends

of the punches 9 and 10 until the card carrier R moves to the position shown in Fig. 281. But meanwhile it is necessary to dispose of the card marked V^1 in the inner guide 13, Fig. 280. As the arms K and K^1 and the card carrier R move to the right, the card V^1 will be taken in the same direction until the right-hand long edge of the card comes into contact with the left-hand side of the frame D. The card V^1 is then arrested, but the card carriers R, with their guides, continue their journey to the right; while this latter part of the movement is taking place, the left-hand long edge of the card ascends the slopes of the plates U, Fig. 282, until the centre of gravity of the card passes to the left of the ridge of U, when the

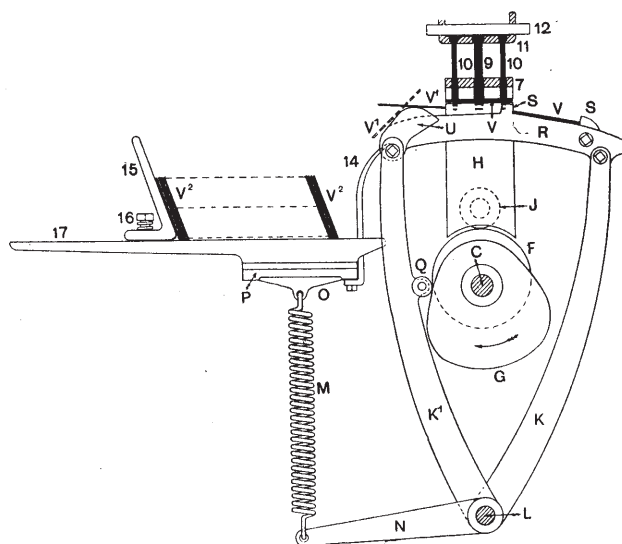

Fig. 282.

card V^1 tilts as indicated by the dotted position, and finally drops on to the curved guide 14 and against the sliding brackets 15, if this is the first card, or else joins those cards which have already been punched, as indicated by V^2 . These brackets 15 are held lightly in position by weak springs and bolts 16, Figs. 277 and 282, while the two plates 17 have slots 18, Fig. 279, in which the bolts 16 slide, along with the guides 15, as the cards accumulate. Each time the arms K^1 reach the extreme left-hand position they enter the slots 19, Figs. 279 and 280, lettered only in the former, and push the cards V^2 and the brackets 15 to the left and through a distance equal to the thickness of the card; the arm K^1 is shown in contact with the last card in Fig. 280. Fig. 277 shows two cards on the plates 17, Fig. 280 shows three cards, while several cards are indicated

to be in position in Fig. 282, although the first four and the last four only are drawn. The plates 17 are fixed to the plates P, Fig. 279, and the latter are in turn fixed to the projecting arms 20 of the frame D, Fig. 277.

The three plates 12 which cover the heads of the peg- and lace-hole punches 9 and 10, and the upper block 11, are reproduced in position in the plan view, Fig. 283, while detached views of the plates on a much larger scale appear in Fig. 284. Each plate has three recesses as shown, so that it is possible to cut cards for 400's, 500's, and 600's jacquards without

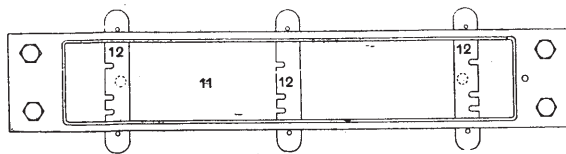

FIG. 283.

removing the punches. Thus, with four lace-hole punches in each row in the plates, and one peg-hole punch at each end, the plates would be placed so that the 2nd and 3rd lace-hole punches would be operated for 400's or 8-row cards, and while the operation of punching was proceeding, the 1st and 4th punches in each row would rise in two of the three slots and have no effect on the cards. The punches indicated by the dotted circles in the left-hand enlarged plate 12, Fig. 284, would therefore punch

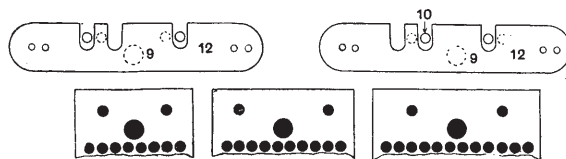

FIG. 284.

the required holes, as indicated by part of a 400's card immediately below the plate 12.

With the plate 12 in the other position on the right—that is, with lace-hole punches Nos. 2 and 3 under the slots—the punches Nos. 1 and 4, shown by dotted circles, would act on the card; this arrangement would do for 10-row or 12-row machines—500's or 600's jacquards—as exemplified by the 10-row and 12-row cards respectively.

It will be evident that the lace-holes for the 12-row card are in the 3rd position from each end, but, as already stated, this position of the holes has a tendency to increase the life of the jacquard card. In some card-cutting rooms the plates 12 are turned through 180°, and the same lace-hole punches used for all cards; in this case it is obvious that the

position of the lace-holes, being constant with regard to the peg-hole, would be as follows :

For 400's or 8-row cards :	the 2nd hole from each side.
„ 500's or 10-row	„ „ 3rd „ „
„ 600's or 12-row	„ „ 4th „ „

The positions of the holes for the 600's cards are, if anything, then too far from the long edges of the card.

In order to supply the approximate times when the various operations take place, we might take as our starting-point in the cycle of operations that moment when the arms K and K¹ commence to move to the left in the line drawings, and to the right when viewed from the balance-wheel end illustrated in Fig. 276. We have chosen the latter view because the direction of motion is clockwise when observed from this end of the machine. The particulars appear in Table XII.

TABLE XII

At 360° or 0° : the arm K is full out at the feed side, and is just commencing to move forward with the card.

At 110° : the arm K is full in with the guide 3 of the card carrier R and the card V under the punches.

At 180° : the arm K begins to move out again.

At 270° : the arm K is full out, and remains out until 360°.

At 90° : the block H commences to rise.

At 120° : the block H reaches the clearing plate 7.

At 220° : the block H and the clearing plate 7 are in their highest positions.

At 270° : the block H and the clearing plate 7 commence to move downwards.

At 320° : the block H leaves the clearing plate 7.

At 360° : the block H is in its lowest position.

About 0° : a card V is fed into the guide 3 of the card carrier R.

At 110° : the card V is under the punches.

At 115° : the card V, moving upward with the block H, reaches the clearing plate 7.

At 200° : the holes are cut in the card V.

At 345° : the card V is forced off the end of the punches by the clearing plate 7, and drops into the guide 13 of the card carrier R.

At 345° to 360° : another card is fed into the guide 3.

At 110° : the newly inserted card has been carried under the punches in guide 3, and the first card is now in guide 13 with the long edge of the card close to the plates U.

At 200° : while the arms of K and K¹ are moving outwards, the rear edge of the card in guide 13 comes into contact with the frame or block, and the continued movement of the arms causes the front edge of the card to mount to the ridges of the plates U.

At 225° : the card is on the top of the ridge of U, and ready for tilting.

At 240° : the card drops on to the curves of the arms 15, and immediately joins those which preceded it to form the group as illustrated in Fig. 282.

It will thus be seen that in each cycle there are three cards in the machine if the cards are fed in as illustrated in Fig. 282; if they are fed in later, the back card will, of course, have joined the group on the plates 17.

A third type of peg- and lace-hole machine, also provided with a clearing plate somewhat similar to that illustrated in Fig 269, and in the machine illustrated in Figs. 276 to 284, and embodying the general type of actual punching blocks and punches, is fitted with a cylinder at the feed side and a similar cylinder at the delivery side. A series of metal cards formed into an endless chain passes over these two cylinders, and thus bridges the gap between them. The ordinary cards to be cut are fed by hand on to these metal cards at the first cylinder, and the metal cards carry the blank cards forward successively between the punching plates and under the punches where the peg- and lace-holes are cut; finally the cards are dropped from the delivery cylinder into a conveniently placed box immediately under the cylinder.

CHAPTER XVI

AUTOMATIC PEG- AND LACE-HOLE MACHINES SEPARATE AND COMBINED WITH LACING MECHANISM

FIG. 285 illustrates an automatic peg- and lace-hole machine in which the cards are stacked in a pile inside a magazine, as clearly shown. The method of driving the punching block is by means of eccentrics, and the cards are fed into the machine by suitable carriers, which select the cards singly and successively from the bottom of the pile and place them under the punches. After they are punched the cards are withdrawn from the punching blocks and deposited into another pile at the delivery side as indicated immediately behind the right-hand eccentric.

Although there may be some advantages in the automatic machine over that of the hand-fed machine, the chief advantage of an automatic peg- and lace-hole machine results when such a machine can be used successfully in conjunction with a card-lacing machine. A photographic reproduction of a combined peg- and lace-hole cutter

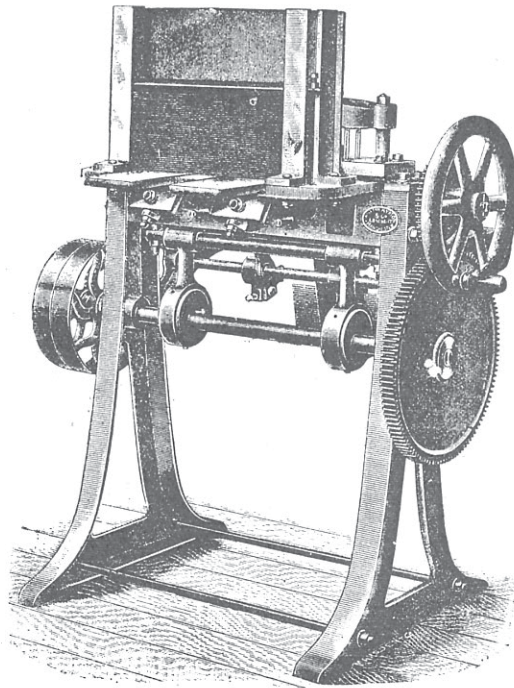

FIG. 285.

and lacing machine appears in Fig. 286. It is made by Messrs. John T. Hardaker, Ltd., Bowling Ironworks, Bradford, and consists of the two

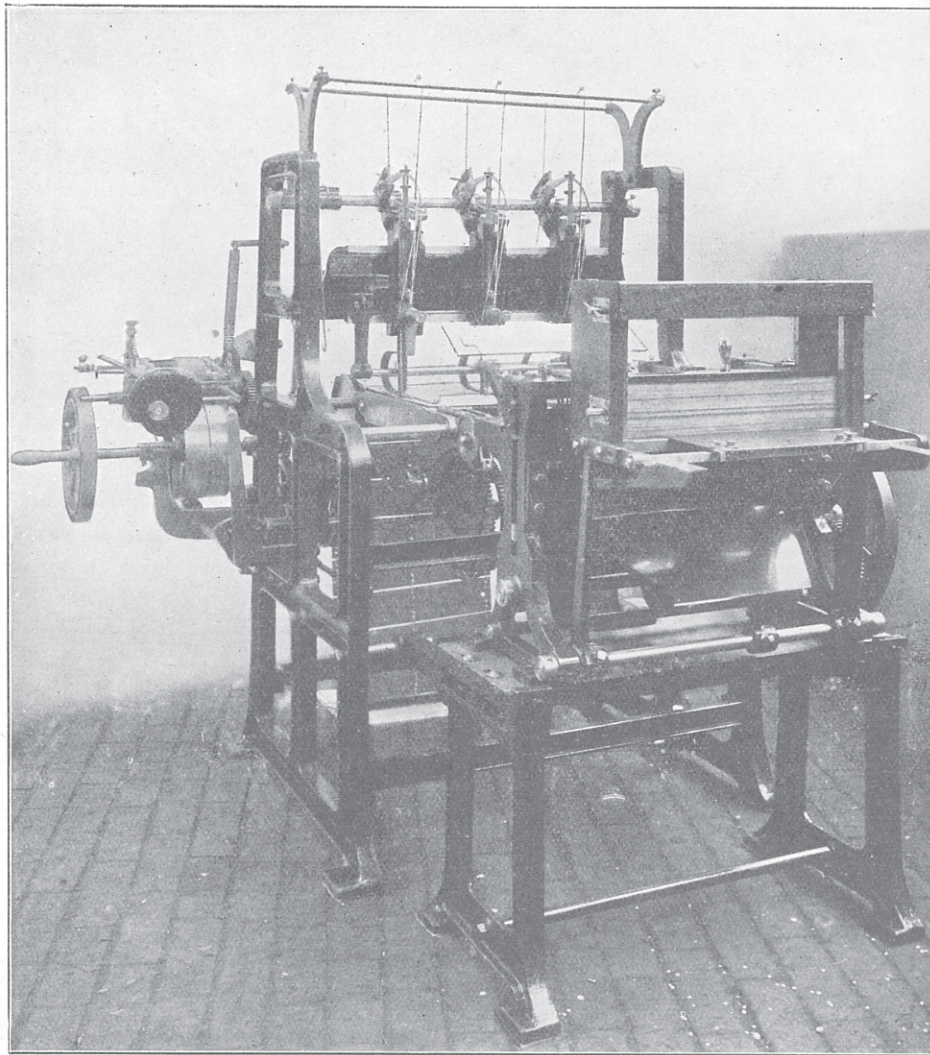

FIG. 286.

machines arranged in tandem. The peg- and lace-hole cutter is in the foreground, while the lacer, which is identical with the one already fully illustrated and described in Chapter XIII., is at the back. The view is taken from the pulley side of the lacing machine, and

hence the spool-winding apparatus for the spools of the shuttle is in view.

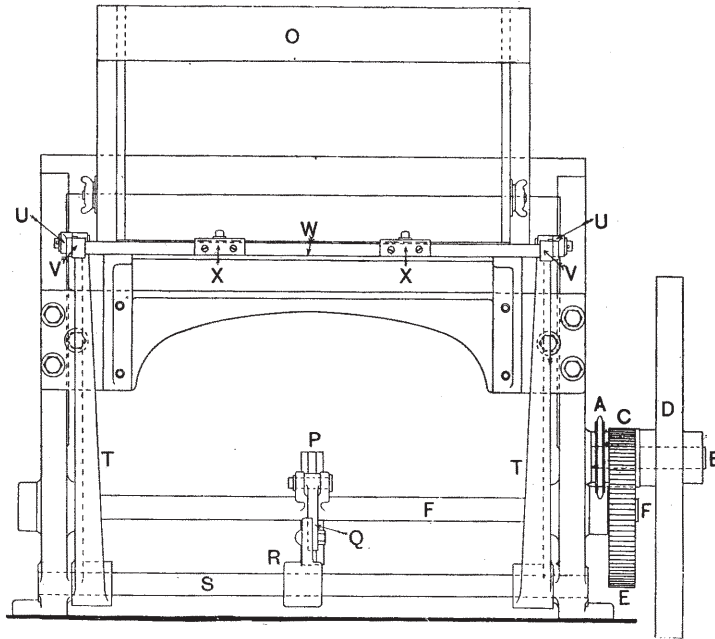

FIG. 287.

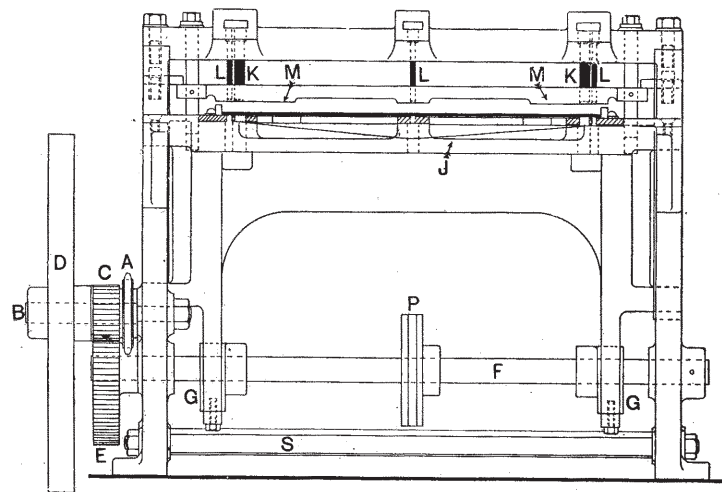

FIG. 288.

A suitable receptacle or magazine is provided for storing the cards, and a pile of cards is shown in position, the magazine being about half full.

The mechanism of the automatic peg- and lace-hole machine, and the method by means of which it is driven from the lacing machine, are displayed in the line drawings, Figs. 287 to 295.

On the cam-shaft R of the lacing machine illustrated in Figs. 215 to 236 is placed a sprocket-wheel of 60 teeth, and this wheel drives by means of a chain a sprocket-wheel of 20 teeth on a stud bolted to the framework of the automatic peg- and lace-hole cutter. This latter sprocket-wheel is

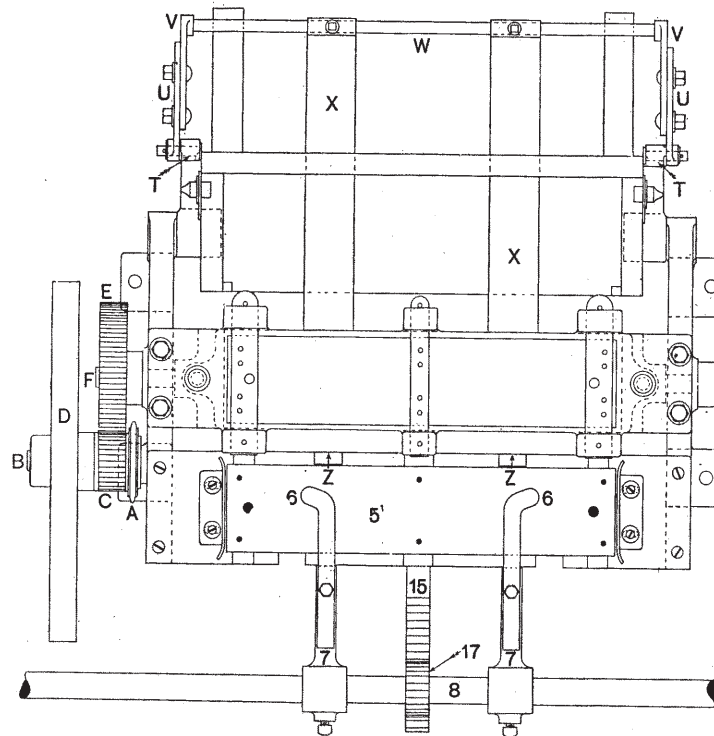

FIG. 289.

shown at A in Figs. 287, 288, and 289. The first of these three illustrations is an elevation of the feed side, the second is an elevation of the delivery side, and the third is a plan. On the same stud B which carries the sprocket-wheel A is a pinion C of 30 teeth, and a balance-wheel D. The pinion C drives a wheel E of 90 teeth on the main shaft F of the machine. In this way the automatic peg- and lace-hole cutter is driven from, and in unison with, the lacing machine.

The elevation of the balance-wheel end of the peg- and lace-hole machine is illustrated in Figs. 290 and 291, while Fig. 292 illustrates part of the

elevation of the delivery side. The method by means of which the actual punching takes place is similar to that of the machines already described; the unique feature of this machine is that of working in conjunction with the lacing machines.

On the main shaft F are two eccentrics G—one near each side frame as shown in Fig. 288. These operate on the underside and in the recessed part of forks H, Fig. 291, and through these on the lower punching block J, Fig. 288, which extends between the two forks H. The upper part of this punching block J contains three sections, as shown in the latter figure,

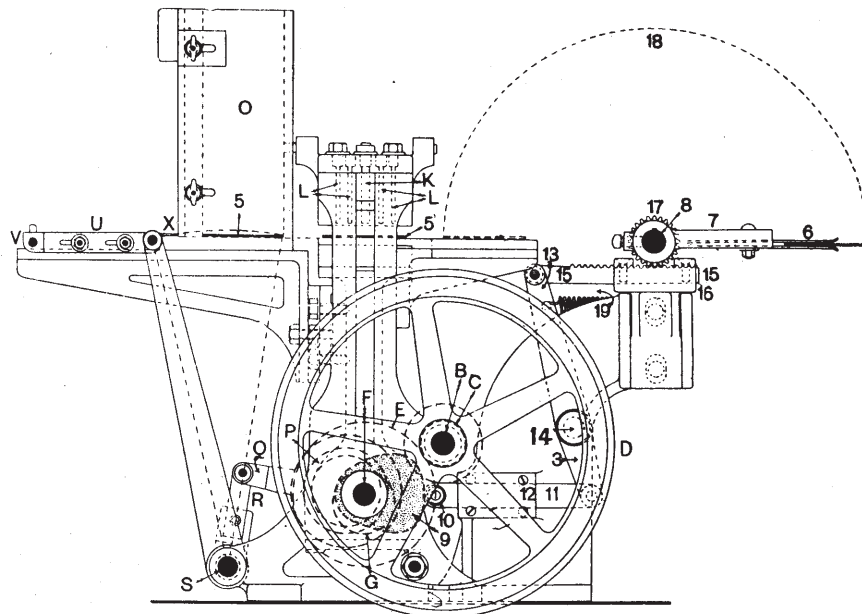

FIG. 290.

the two end sections being immediately under the peg-hole punches K and the end lace-hole punches L; while the centre section is under the central lacing punches L. The underside of the clearing plate M is shaped to correspond, and is provided with the usual springs N, Fig. 292, to force it down and to force the cards off the ends of the punches at the proper time. In Fig. 290 four lace-hole punches are shown, and their positions are also indicated in the plan view in Fig. 289. These may be arranged to operate on the cards in a method somewhat similar to that already illustrated in Figs. 283 and 284, and described in connection with the "Ayrton" machine.

The stack of cards is situated in the box O, Figs. 287 and 290, and the cards are pushed out singly and successively, and under the punches L

and K by the action of a box-cam P on the main shaft F, Fig. 290, anti-friction bowl lever Q attached to the short lever R on the shaft S, the two arms T (see Fig. 287), and subsequent connections to be described and illustrated shortly.

It will be understood that as the shaft F and box-cam P rotate, the arm Q will, through lever R, cause the shaft S to oscillate, and thus cause the two long arms T to move between the limits indicated by the dotted lines, Figs. 290 and 291. The upper ends of the levers T are connected to the brackets U—shown best in Figs. 289 and 290—and to the latter are bolted two adjustable brackets V, the ends of which support the rod W.

In connection with the further description, the sheet of details illus-

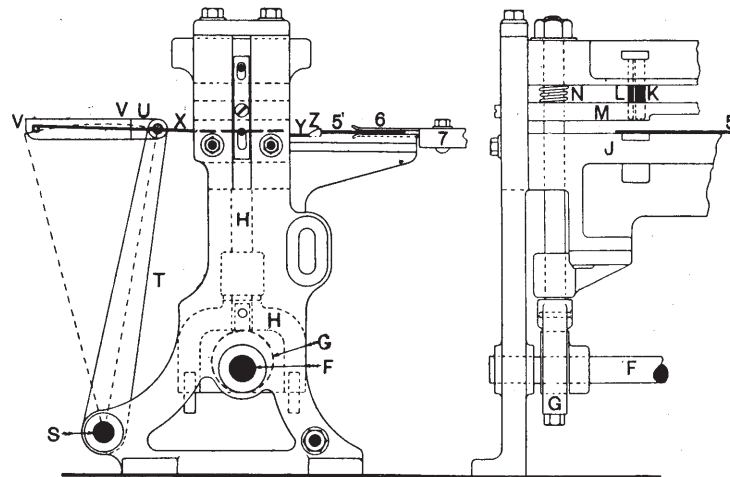

FIG. 291.

FIG. 292.

trated in Fig. 293 should be consulted along with Figs. 289, 290, 291, and 292. Set-screwed to the rod W are two plates X, the shape of each of which is indicated in the lower detached figure in Fig. 293. To the underside of each plate X is riveted a shorter spring plate Y, the end of which is fixed to a pushing plate Z, while attached to the underside of the spring plate Y is a short rod 2 so arranged that its ends 3, shown in solid black, can pass under the plates 4 in a way to be explained immediately. (A wide plate is sometimes used as suggested in the upper view in Fig. 293 and in Fig. 286.).

Let the cycle of operations start with the lever T, Fig. 290, in the full back position as indicated; then the rod W and the plate X will be in the positions shown in the lower drawing in Fig. 293, where a number of cards 5 are shown in the magazine O. For the sake of clearness we may assume

that there is a card 5¹ under the punches as depicted in the latter drawing and in Fig. 290.

When the levers T move clockwise from the balance-wheel end, it is

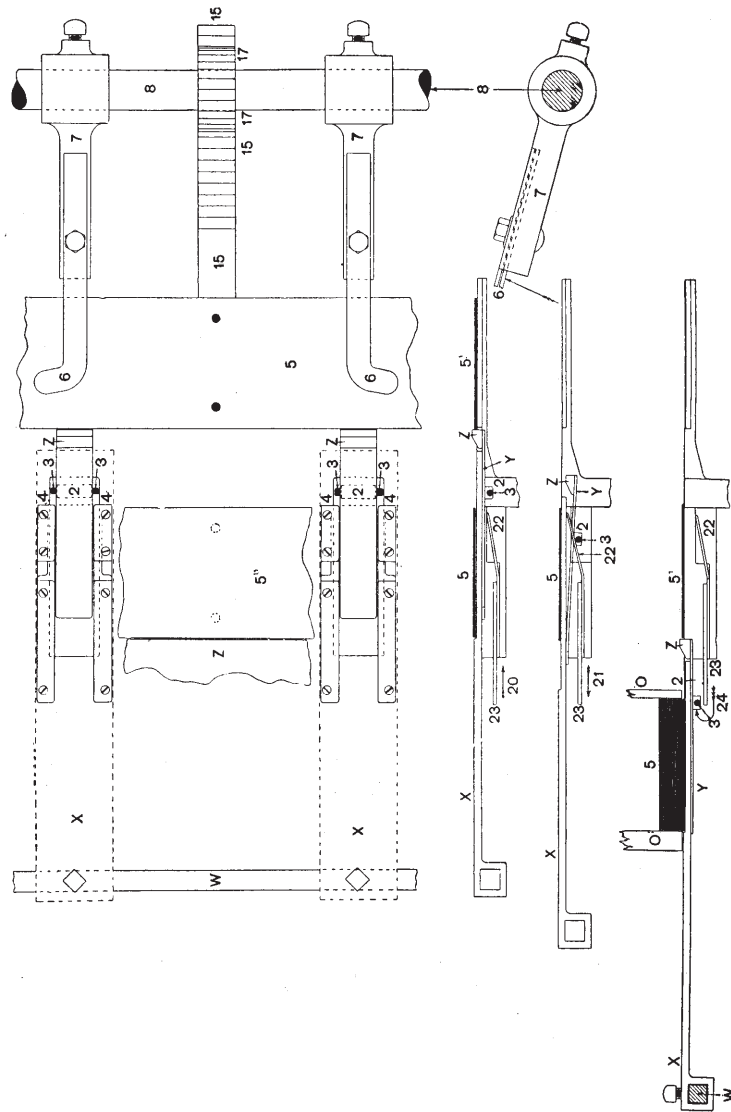

clear that the two plates X will move to the right, and in doing so, one of the cards 5 in Fig. 293 will be carried from under the pile in the magazine by the notch on plate X; at the same time, the part Z, attached to the

spring Y, will push the card 5¹ in the same direction until the two cards occupy the positions represented in the upper elevation. Then the levers T will be in the full forward position as shown in Fig. 291, the rear card will be under the punches K and L, and the front card will have been forced between the grips 6 of the card feeder 7, fulcrumed at 8, and into the dotted position in Fig. 290.

While the machine is punching the holes in the card, and the levers T and the plates X are returning to their original position, the card 5¹, Fig. 291, has to be transferred from this place to the pegs of the chains of the card-lacing machine. This operation is performed by the mechanism illustrated in Fig. 290. A cam 9, shown stippled, operates on an anti-friction roller 10, and moves the rod 11 in slide 12. The lower end of the lever 13, fulcrumed at 14, is attached to the end of rod 11, while its upper end is attached to the rack rod 15, which is capable of being moved in slide 16. The teeth of the wheel 17 on the shaft 8, and midway between the card feeders 7, are in gear with the teeth of the rack 15; hence, as the main shaft F rotates, the cam 9 and subsequent mechanism will cause the ends of the card feeders 7 to move in a semi-circular path 18, from the inner position—that indicated by the dotted lines of a card—to the outer position, as shown by the card feeder, while the spring 19 will cause the card feeder to return in proportion as the cam 9 presents its decreasing thickness to the anti-friction bowl 10.

It will, of course, be understood that the cam 9 must be set so that the grips 6 of the card feeder 7 will be in the position indicated in Fig. 291 just before the card 5¹ reaches the mouth of the grips 6, and that the action of the rack 15 will cause the card feeders to complete their semi-circular movement at the proper time in order that the card may be deposited safely on the pegs of the chains of the card lacer, and then be withdrawn from the grips 6 by the movement of the said chains before the return journey of the card feeders is commenced. The dwell on the thick portion of the cam is for the latter purpose.

After each card has, in succession, been pushed from under the punches K and L into the grips 6 of the card feeders 7 by the parts Z, Figs. 291 and 293, it is necessary that in the return journey of the part Z, the latter shall pass under the new card 5 which has just been placed under the punches. The method by means of which this is accomplished will be seen from the three lower figures in Fig. 293. The arrow 20 in the upper figure shows that the parts have been moving, or at present are being moved, to the right; as a matter of fact, the plan view immediately above shows that the forward movement is complete because the card 5¹ is in the grips 6. In the middle figure of the three elevations the grips 6, cut short, and the card feeder are moving clockwise, and the plate X with its complement is

moving backwards, as indicated by the arrow 21. Soon after these parts commence to move backwards, the ends 3 of parts 2 are compelled to follow the path on the underside of the flat springs 22 until the ends 3 reach and pass the end of the plate 23, when the spring Y carries the pushing part Z into the active position; the arrow 24 in the lower illustration in Fig. 293

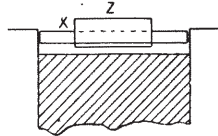

FIG. 294.

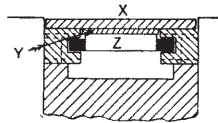

FIG. 295.

shows that this action has just been completed, and that the part Z is again in position for pushing a card from under the punches K and L into the grips 6 of the card feeders 7. Each time the parts move forward the ends 3 extend the spring 22 from the upper side in order to enable them to reach the full forward position.

Figs. 294 and 295 are sections of the parts near the active end of plate X. The former shows the end of plate X and the pusher Z when viewed from the right-hand side in Fig. 293; while Fig. 295 shows the ends 3 (Fig. 293) of the rod 2 in the race which guides them when the parts are moving to the left and underneath the new card which has just been placed under the punches of the machine.

It should be mentioned that parts are made to meet the necessary requirement involved with cards of different widths.

Although it is rather difficult to obtain any particular information regarding the actual structure of machines made in other countries, and used for similar purposes, it is interesting and instructive to note the difference in appearance between foreign and home machines. The

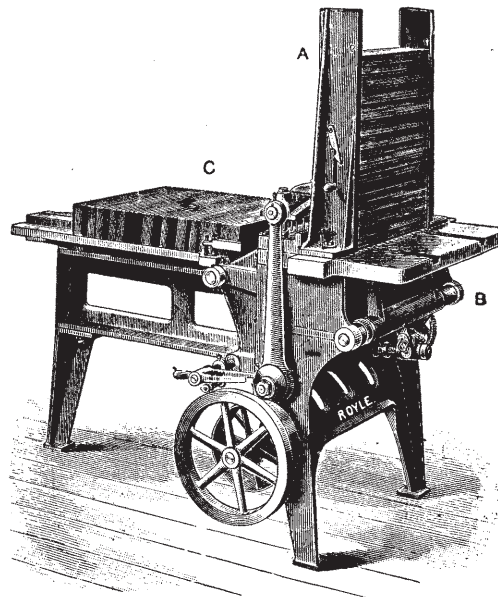

FIG. 296.

reader, however, will know by this time the general characteristics and requirements of peg- and lace-hole machines, as well as of lacing machines, from the foregoing fully illustrated examples, and will therefore be able to form a good idea of the other less fully illustrated types which we now introduce.

An American automatic peg- and lace-hole machine is illustrated in Fig. 296. It is obviously of substantial construction, and the lower part or table support is on three legs. The cards are fed as usual between the

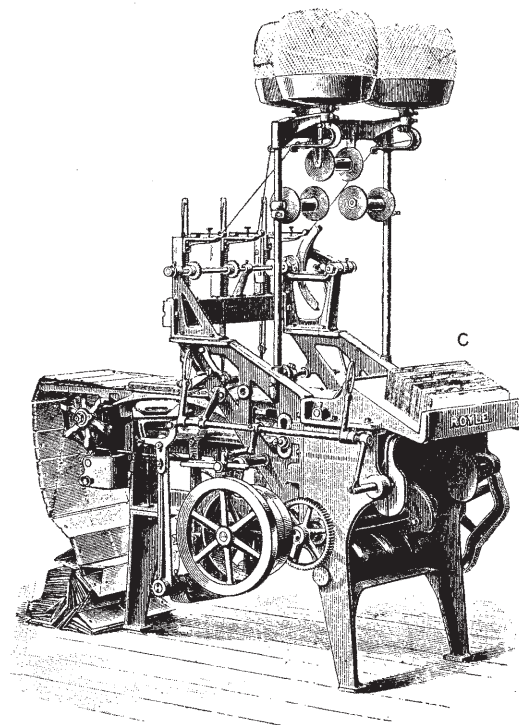

FIG. 297.

vertical guides of the magazine A, which holds from 500 to 600 cards. A reciprocating feeder, fulcrumed on the shaft B, withdraws the bottom card from the pile and carries it to the punching blocks, where the peg- and lace-holes are cut in a very similar manner to that already illustrated and described. The card is then ejected from between the punching blocks to join those at C, which have been treated previously in precisely the same way. As in other machines for the same class of work, provision is made for both 400's and 600's cards.

The cards C may then be taken to the inclined stand of the hand-feed lock-stitch lacer illustrated in Fig. 297,

or be laced by hand. The lacing mechanism of the machine in Fig. 297 is identical with that of the automatic lock-stitch lacer illustrated in Fig. 298. The cards in the card-guide or magazine A are operated as in Fig. 296, and the peg- and lace-holes cut by very similar mechanism; but, as the title of the machine indicates, the cut cards are fed automatically, and direct connection between the cutting and lacing mechanism obtains, so that the cards may be placed mechanically on the pegs of the sprocket-chains of the lacing section. The type of lacing, and the manner in which it is performed, are of the same nature as those of the "Singer"

and "Rapid" machines, where a series of vertical needles above the cards work in conjunction with a corresponding number of reciprocating shuttles below the cards. The lacing twine comes from the balls D or from spools or bobbins, and the cards are delivered as exemplified at E.

Fig. 299 illustrates an automatic peg- and lace-hole machine and a lacing machine working together, with a handy form of card truck F upon which the laced cards may be arranged as shown, and by which they may be taken to the loom. The same type of magazine A is used, but the stitching mechanism differs from the others in that the lacing is not of

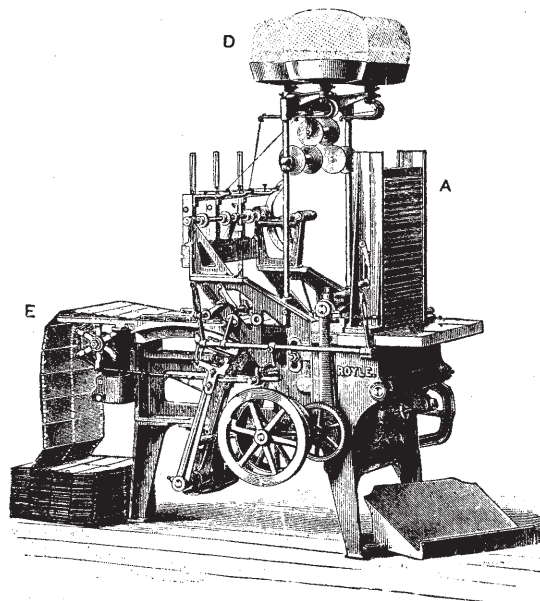

FIG. 298.

the lock-stitch type, but of the loop-stitch type.

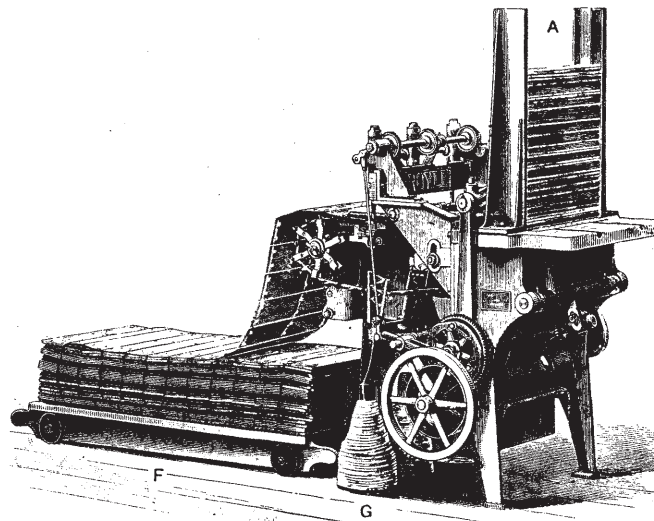

FIG. 299.

the lock-stitch type, but of the loop-stitch type. This type of stitch,

although having a tendency to ravel or run back, enables the machine to run at a higher speed than the lock-stitch type. No shuttles are required in machines with a loop-stitch, and the lacing twine in this case is supplied from the bottle-shaped bobbins G placed on the floor. It is claimed that 40 to 50 cards per minute can be fed into and laced by this machine.

The function of the peg- and lace-hole machine, as already stated, and as indicated by the name, is, first, to cut the required number of lace-holes in each card so that the necessary number of cards can be formed into a chain ; and, second, to cut the peg-holes so that these may drop over the pegs of the card-repeating machine, and finally on to the pegs of the jacquard cylinder on the loom. The introduction of the peg- and lace-hole machine and the companion machine—the card repeater—is for the sake of production when two or more sets of identical cards are to be prepared for a similar number of looms engaged in weaving the same design concurrently.

CHAPTER XVII

ORDINARY-PITCH AND MEDIUM-PITCH REPEATING MACHINES

In connection with nearly all schemes of repeating mechanism for jacquard cards, it is the practice to prepare the cards with the peg-holes and lace-holes by means of some type of peg- and lace-hole machine as already demonstrated in Chapters XV and XVI. The peg-holes are utilised as guides during the cutting of the pattern holes in the repeating machine, and also serve the purpose of guiding and holding the cards in position on the cylinder of the jacquard during the operation of weaving.

There are two peg-holes near each end of the cards used for Brussels and Wilton carpet weaving, but in nearly all other British systems there is only one peg-hole near each end of the card. In an American system, as practised by Messrs. John Royle & Sons, Paterson, N.J., two peg-holes are cut at each end of the card in the peg- and lace-hole machine; these four holes serve only as guides for the cards during

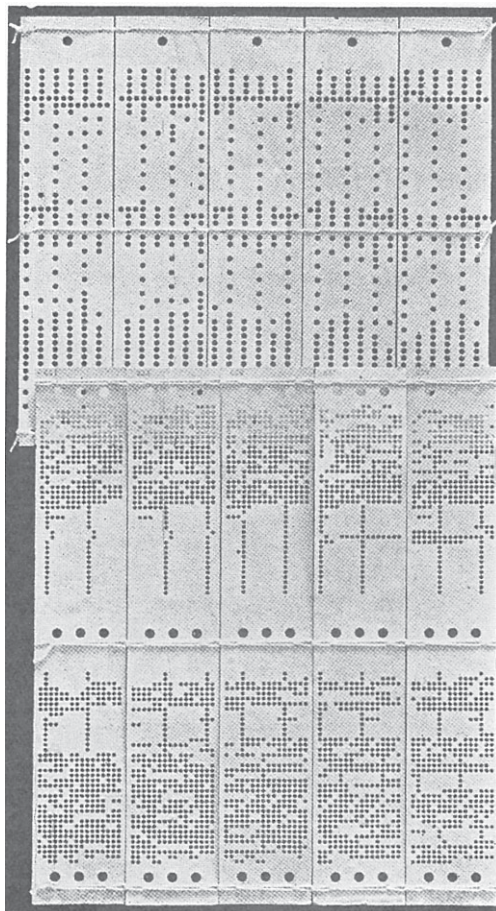

FIG. 300.

their passage through the repeating machine; a third peg-hole, however, is cut between the above-mentioned two holes, in the repeating machine, at the same time that the holes for the pattern are being cut. This middle hole is intended for use with the pegs on the jacquard card cylinder. In this way, the peg and pattern holes are made with absolute accuracy, and there is less danger of the peg-hole being damaged in the repeating machine than there is by the usual method. The ordinary arrangement of cards with a single peg-hole is shown in the upper part of Fig. 300, while the cards with the three peg-holes are shown in the lower part of the same illustration. The figure also illustrates two distinct types of lacing.

Whatever method of preparation is adopted, it will be understood that the cards must be numbered consecutively—if all the cards are in one set—for the guidance of the weaver and others during the operation of weaving. There are different methods adopted for inserting the numbers on the card. The numbers are often written in ink on the ends of the cards prior to the operation of lacing. At other times they are printed on the cards by a hand-operated numbering machine. A series of movable or rotatable rings of numbers are accommodated in a swivelling frame situated

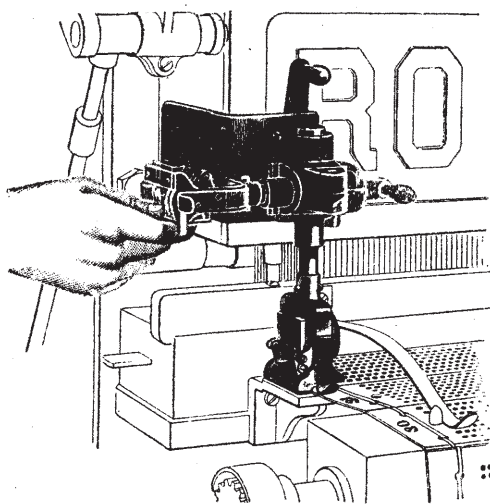

FIG. 301.

in the outside frame, and attached to and operated by a sliding block. The downward pressure of the block causes the swivelling frame to move downwards and make half a revolution in order to bring the numbers in contact with the card. As the block moves upwards under spring pressure, the swivelling frame rotates back through half a revolution to place the numbers upwards and to bring them into contact with the inking pad. In the upward movement, the type for the number just impressed upon a card is replaced by the next higher number, so that the impressions may appear consecutively on the cards. The unit ring of numbers moves one division each time, while the tens and hundreds rings move proportionately.

In the American system just mentioned, a similar numbering machine is fitted to the framework of the repeating machine, as illustrated in Fig. 301. The block of the numbering machine moves automatically in unison

with the rising and falling of the repeater, and in unison with the cards as they leave the cutting blocks of the repeater. The illustration in Fig. 301 shows that cards for No. 30 and No. 31 have already been printed, and that card No. 32 will be printed next. The whole apparatus is made to swivel so that it may be moved by hand through 90 degrees with

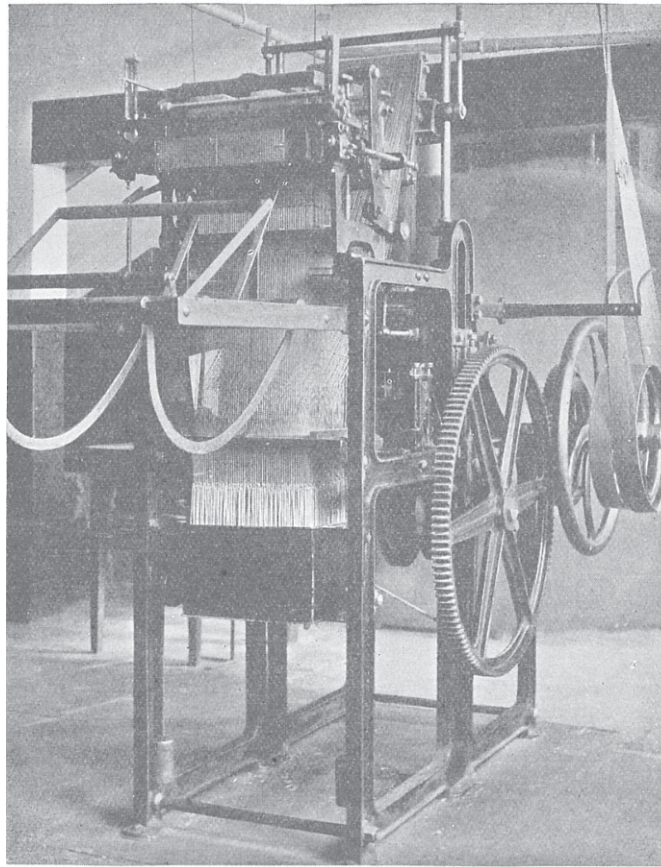

FIG. 302.

respect to the actual parts of the repeater (the faint part of the illustration); this provision is essential or desirable to enable the attendant to set it to zero when starting to repeat a new set of cards, or to adjust it to any other number if any irregularity occurs in connection with the repeating machine and the numbering apparatus. Repeating machines are made to suit the various pitches.

COARSE-PITCH REPEATING MACHINES.—As in other types of machines, there are different makes of repeaters, each one of which possesses its own advantages, and probably its own peculiarities. The first machine which we shall illustrate is the card repeater made by Messrs. Devoge & Co., Limited, Manchester. A general view of this machine, as seen from the feed end and driving side, appears in Fig. 302. A line drawing of the pulley or driving side of the machine is illustrated in Fig. 303; Fig. 304 is a lithographic reproduction of the opposite side of the machine and the delivery end; while details of some of the mechanism appear in Fig. 305.

The machine illustrated in Fig. 302 is shown to be driven from a line shaft near the roof, and the balance- or hand-wheel C is immediately behind the fast and loose pulleys A and B. In the machine illustrated by the line drawings the drive is from an underground shaft, and the balance- or hand-wheel C is behind the spur-wheel D, but both are carried by the shaft E. The latter extends across the machine, is supported by bearings in the main side frames F, while the overhanging end at the driving side is supported by the auxiliary frame H. The spur-wheel D communicates the motion to the larger spur-wheel J, the direction of rotation of both wheels being indicated by the arrows.

The large wheel J is on the heavy main shaft K of the machine; this shaft also extends to the opposite frame, and indeed projects a little outside the frame in order that it may carry the box-cam L for the jacquard.

The cards which have been cut in the piano machine from the actual design, and subsequently laced by any of the methods enumerated, are first brought to the repeating machine and suspended on the card cradle M, Fig. 303. This cradle is supported by two rails N fixed to the main frames F of the repeater. Adjustable bars O serve to hold the rollers P,

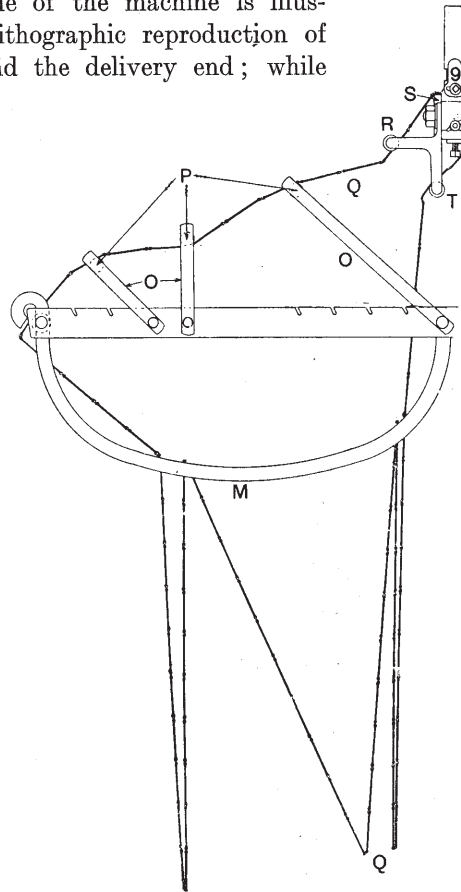

FIG. 303.

and to place them in the most suitable position for guiding and tensioning the pilot chain of cards Q as they pass from the cradle M to the roller R, and thence to the cylinder S of the jacquard. As the cards leave the cylinder S in the usual manner, they pass behind the roller T, and thence direct to the card cradle M.

The action of the jacquard in general need only be described briefly, but it may be observed that the box-cam L on the shaft K,

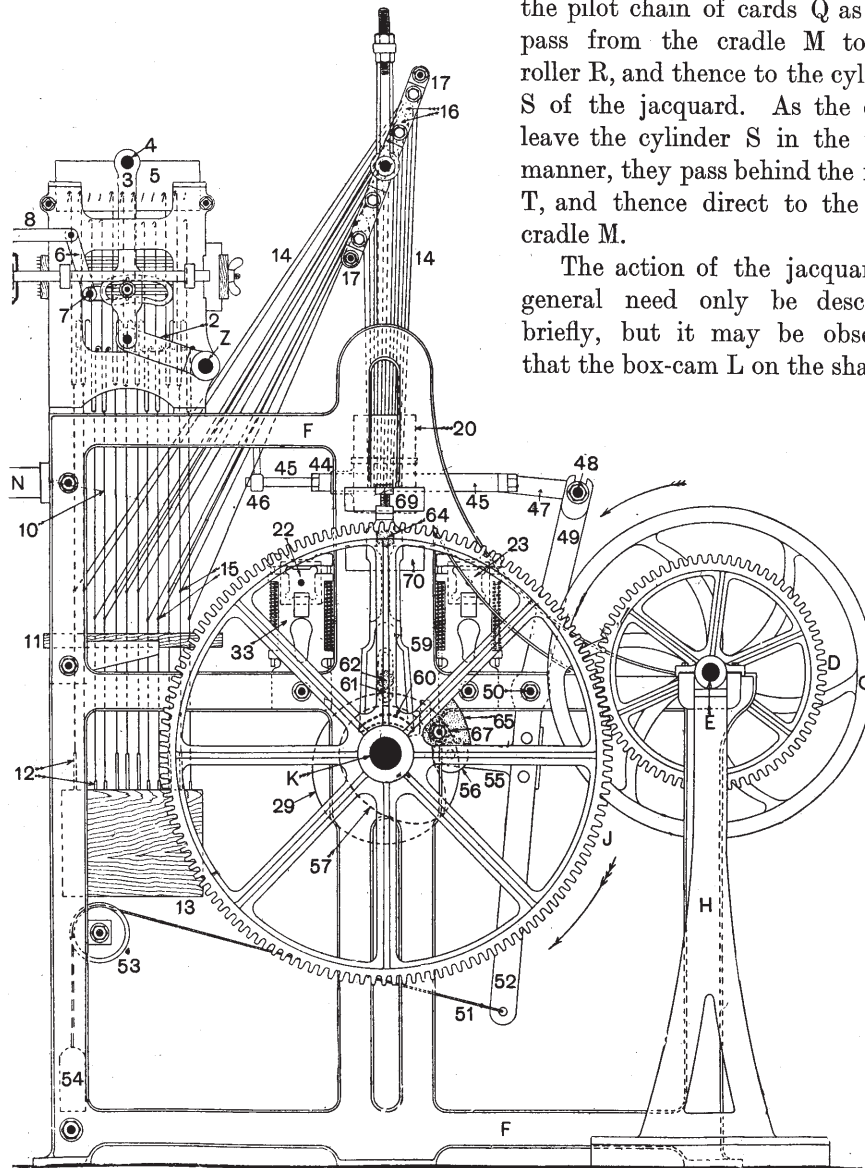

FIG. 303.

Figs. 306 and 307, operates the anti-friction bowl on the bracket U, and therefore the lever V fulcrumed at W. The connecting-rod X joins the end of the lever V to the lifting lever Y fulcrumed on the rod Z

of the jacquard. (Parts U to Y are omitted in Fig. 303 in order not to complicate the view from the driving side.) Two shorter levers 2, also fixed to rod Z, serve to raise and lower the griffe 5 as required through the medium of the pendent arm 3 and the projecting stud 4. The concentric slot in the pendent arm 3 operates the bell-crank lever 6 fulcrumed at 7; and since the upper end of this lever is attached to the bar 8, and the bar attached to the batten 9 of the cylinder S, it follows

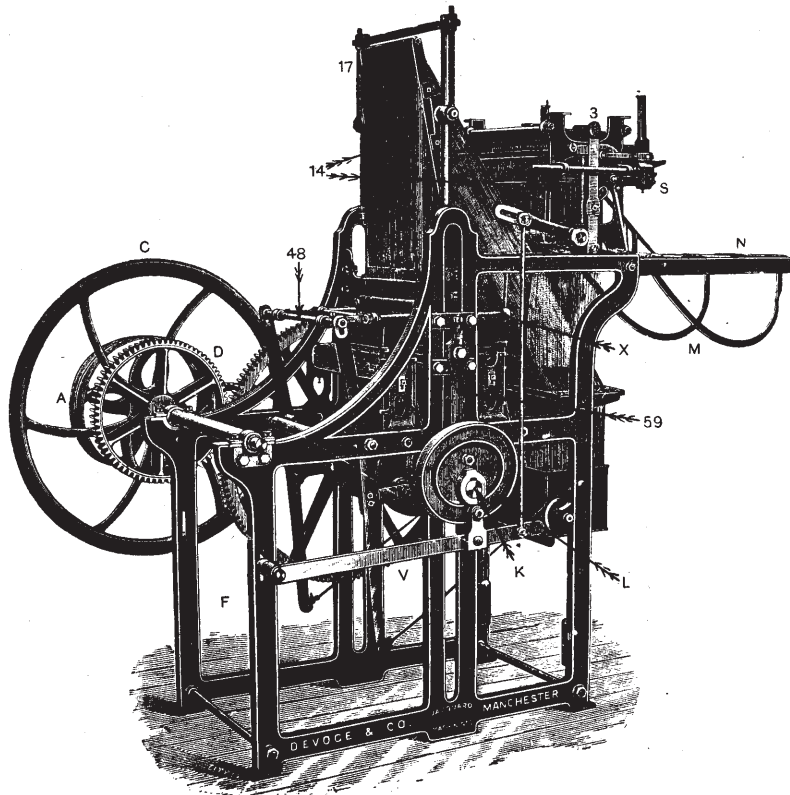

FIG. 304.

that the desired to-and-fro motion of the cylinder S will result as the box-cam L rotates.

The usual complement of 612 needles and 612 hooks is provided, and they are arranged as indicated in Figs. 303 and 306. There are 612 harness cords 10 attached to the bottom bends of the hooks, and the cords pass through a suitably drilled board 11, while their lower ends are tied to 612 lingoes 12, all of which are kept within the prescribed area by the box 13.

A further set of 612 harness cords 14, twelve only of which are shown in Figs. 303 and 306, are attached at 15 to the vertical harness cords 10. The cords 14 pass obliquely upwards to the rollers 16 of the frame 17. The rollers 16 are kept apart by the grid 18, Fig. 307, and the cords 14 pass over the top of the rollers and downwards to the punches 19; each cord has its own roller 16. All the 612 rollers are displayed in Fig. 307, but the bottom row only of 51 shows the cords passing over them and then down to the corresponding 51 punches.

Figs. 308, 309, and 310 should now be consulted in conjunction with Figs. 303 to 307. Fig. 308 is partly a sectional view of the central part of the repeater, while Figs. 309 and 310 also represent sections of the same mechanism, but the parts in these two illustrations are drawn twice the size of the corresponding parts in the remainder of the illustrations.

It is not difficult to see that when the box-cam L, Fig. 306, is in the position shown, the griffe 5 will be in its highest position, and the cylinder S full out as indicated there, and also in Figs. 303 and 308. It is also clear that when the box-cam L has moved half-way round, to the position indicated in Fig. 304, the griffe will be down, and the cylinder S with its card in close contact with the needle board of the jacquard. The latter position is, naturally, that in which the selection of the needles takes place according to the positions of the holes and blanks of the card. In Figs. 303, 306, and 308 it is assumed that the selection has just been made, and that subsequently half a revolution of the shaft K has been made to place the parts in the positions illustrated.

Now it is obvious that those hooks of the jacquard which are lifted will in turn have lifted the corresponding harness cords 10 and lingoes 12. This upward movement of certain cords 10 would slacken correspondingly the attached oblique cords 14; and if the weighted punches 19 were free to descend, it follows that the slackened cords 14 would permit of the downward movement of certain punches 19. The harness cords 10 in

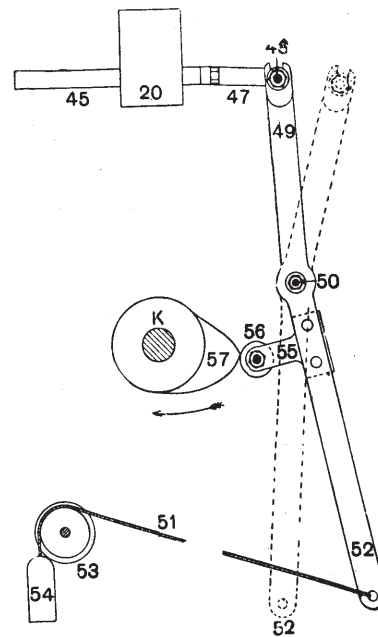

FIG. 305.

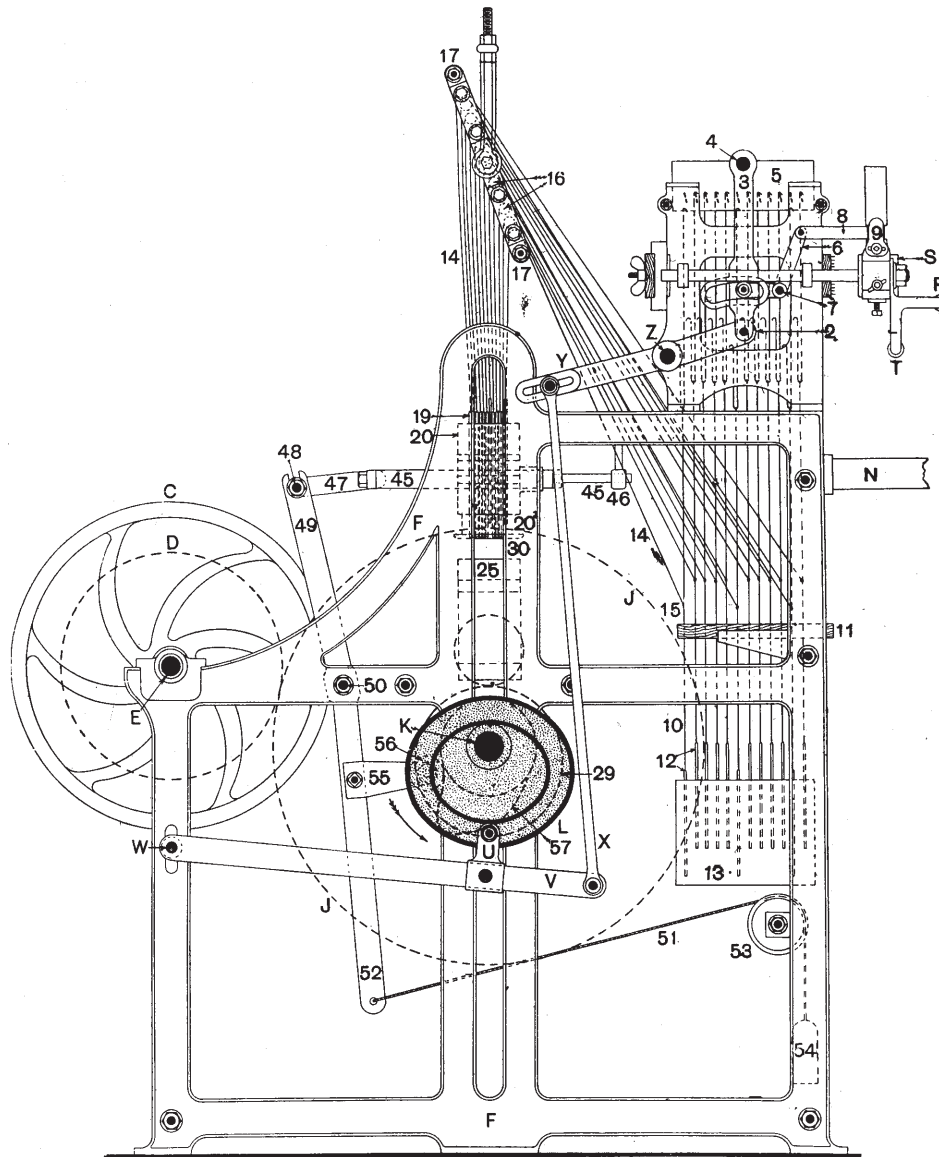

Fig. 306.

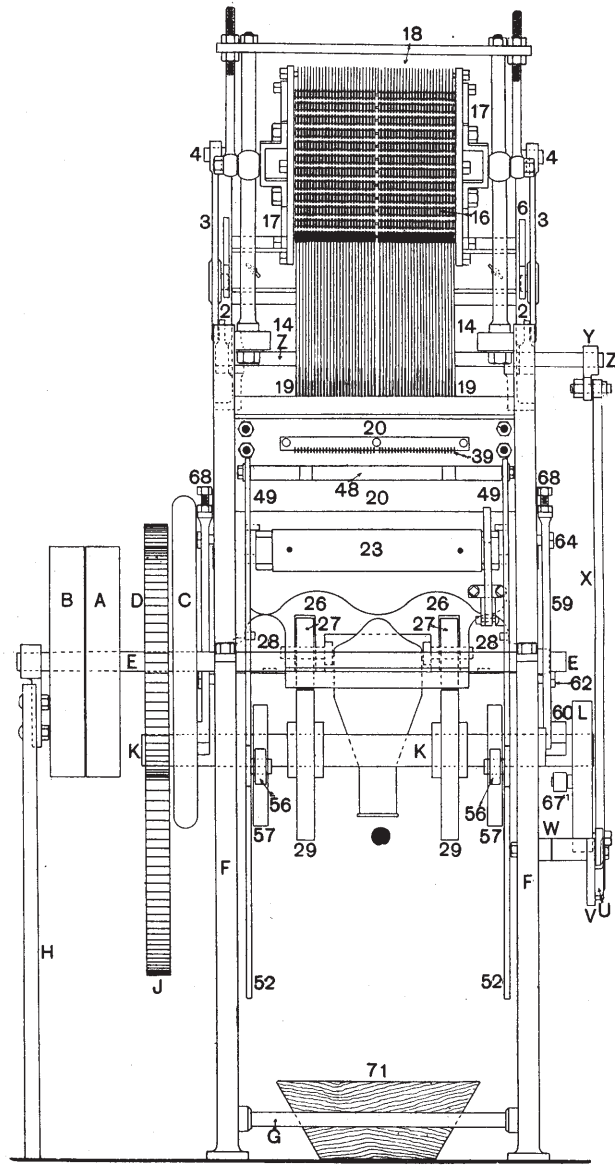

FIG. 307.

Figs. 303, 306, and 308 may be taken to represent three distinct rows of 12, and an examination of the knots 15 will show that the orders are as shown in Table XIII.

The movements of the punches 19 will, of course, be in the opposite direction—*i.e.* downward—to those of the oblique harness cords to which they are attached: the reason for this will be explained shortly. The resulting positions of the punches 19 are shown only in Figs. 306 and 308, and in the enlarged illustration in Fig. 310.

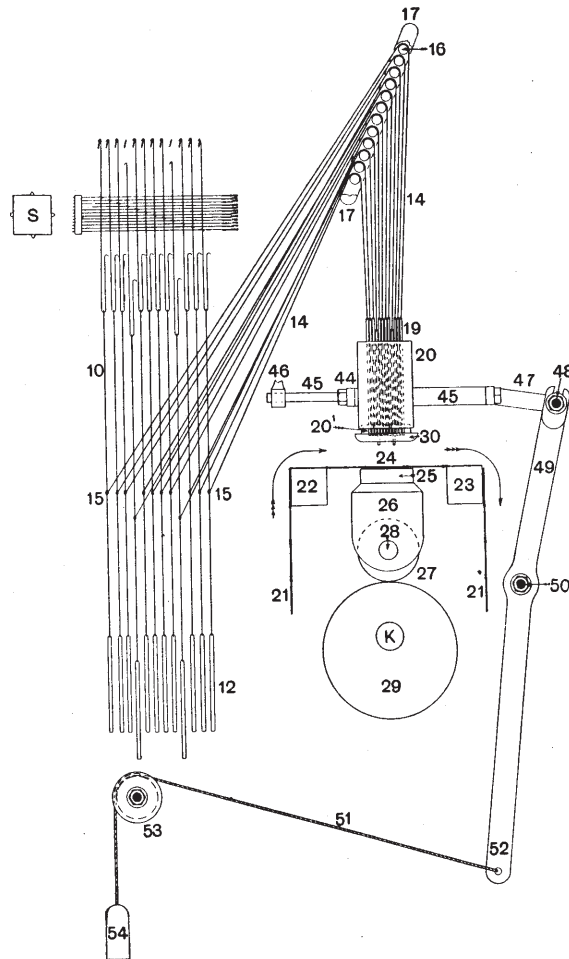

FIG. 308.

There are two conditions necessary with regard to the manipulation of the punches 19 in the punch box 20: First, there must be provision for a free vertical movement on the part of every punch 19, so that when any of the jacquard hooks are raised the corresponding punches 19 may descend with ease to their lowest position; and, second, each punch which has descended, in virtue of a rising jacquard hook, must be held securely in the new position until the operation of punching the card is completed. The method by means of which these two essential conditions are fulfilled will be described and illustrated shortly; in the meantime, we are at liberty to assume that such conditions are satisfactorily achieved by the nature and movement of the mechanism involved.

TABLE XIII.

	Hooks.	Fig. 303.	Fig. 306.	Fig. 308.
Numbers of hooks in short rows. No. 1 hook nearest the cylinder.	1	up	up	up
	2	"	down	"
	3	down	up	"
	4	"	"	down
	5	up	"	up
	6	"	"	"
	7	"	down	"
	8	down	up	"
	9	"	"	down
	10	up	"	up
	11	"	"	"
	12	down	down	"

The cards containing the peg- and lace-holes only, and in a chain form, have to be punched exactly as are those marked Q in Fig. 303, which, as already stated, have been punched from the design. The cards to be duplicated, of which thirteen from the chain are shown at 21 in Fig. 308,

are arranged as shown; five of the cards bridge the gap between the two repeating cylinders 22 and 23, while four are hanging down at each side, and the arrows indicate the direction which the cards follow during the operation. The middle card 24 is shown on the lower punching block 25, which is secured to the block carrier 26. Two recesses in the block carrier 26, Fig. 307, serve to accommodate two anti-friction bowls 27 which rotate on the shaft 28, Figs. 307 to 310. Two large discs 29, set eccentrically on the heavy main shaft K, impart the necessary upward movement to the anti-friction bowls 27, and therefore to the block carrier 26 and lower punching block 25; the blocks descend by gravitation.

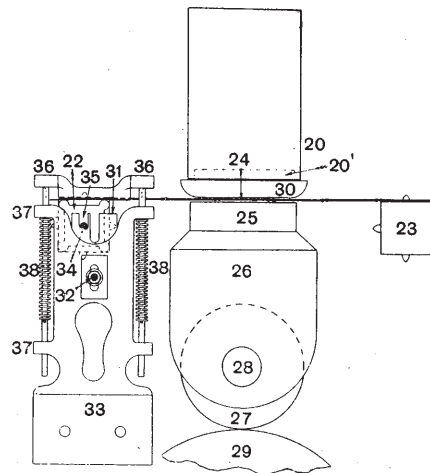

FIG. 309.

In Fig. 308 the eccentrics 29 are in the lowest position; half a revolution will enable them to raise the block carrier 26, block 25, and card 24 to the highest position. An upward movement of about $1\frac{3}{4}$ in. to 2 in. carries the card into close contact with the clearing plate 30, while a further

upward movement of $\frac{1}{2}$ in. will carry the clearing plate 30 to its highest position, and at the same time will cause the brass sliding punch box 20¹ to slide $\frac{1}{2}$ in. into the punch block 20 (punch box 20¹ shown more clearly later). When this movement is complete, the blocks 20¹, 26, card 24, and clearing plate 30 will be in their highest positions, as indicated in Figs. 309 and 310; and if the dropped punches 19 have remained stationary, the card 24 will have been raised above the plane of these punches, and hence holes will appear in the card opposite the ends of the depressed punches. The holes in the card 24, through which the ends of the punches 19 have entered by punching, will correspond exactly with the holes in the card which

operated the needles and hooks of the jacquard.

It will thus be seen that when a card from the chain Q in Fig. 303 is presented to the needles of the jacquard, all needles opposite the holes will remain undisturbed, the corresponding hooks will be raised, and simultaneously the same number and order of punches 19 will be free to descend to the lowest position; then when the block 25 is raised, all the depressed punches will pass through the cards—or, rather, the card will be forced past the ends of the punches—and

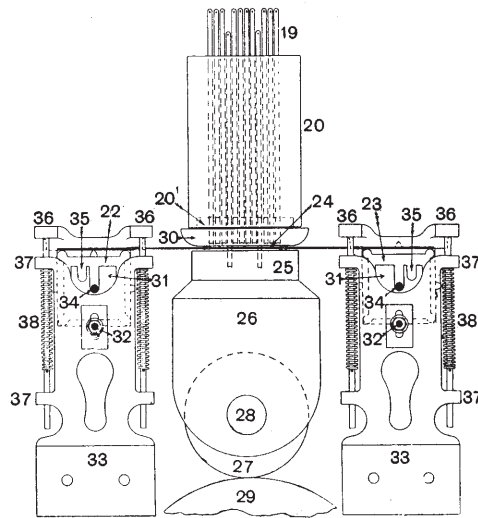

FIG. 310.

hence a complete card is punched with every revolution of the main shaft K.

Before leaving Figs. 308 to 310 we might show what provision is made for repeating the two distinct widths of cards, 8-row and 12-row. In Fig. 308 there are five cards in the stretch between and including the cylinders 22 and 23; there are also five cards in the corresponding positions in Fig. 310. In both figures the cards are 12-row or 600's. In Fig. 309 there are seven cards on the stretch, and these are 8-row or 400's cards. Two cylinder supports 31, Fig. 310, are provided for each repeater cylinder 22 and 23. These supports or blocks 31 can be adjusted vertically by means of the studs 32 in the supporting brackets 33 which are fixed to the central rail of the side frame, as shown clearly in Figs. 302 and 303. When the 600's cylinders and cards are in use, the pins or studs 34 of the cylinders

are entered into the deep slots of the supports 31, as illustrated in Fig. 310 ; but when 400's cards have to be repeated, the studs of the cylinders are entered into the shallow slots 35, as depicted in the single cylinder support in Fig. 309 ; the support for the right in this figure has not been drawn.

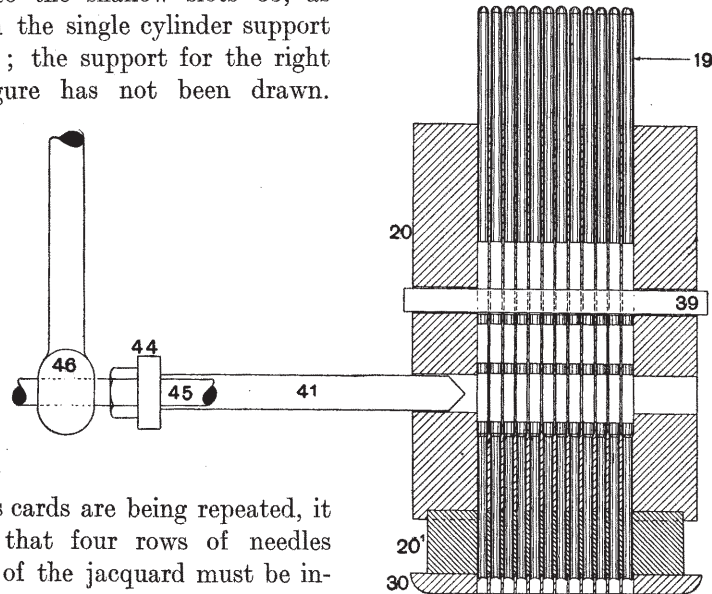

FIG. 311.

When 400's cards are being repeated, it is evident that four rows of needles and hooks of the jacquard must be inoperative. Two long rows of needles at the top of the needle board in the jacquard, and two rows at the bottom, are pressed back and held there by plates, so that the corresponding hooks will remain down and the middle eight rows be operated.

After each card has been cut, and as the block is descending, the hooks of the upright jacquard catches are caused to come into contact with the lanterns on the ends of the repeating cylinders 22 and 23, and thus the two cylinders are simultaneously turned one-quarter of a revolution so as to bring the cards successively into position under the punches 19. The repeating cylinders are not perforated on each face like the jacquard cylinders, but otherwise the structure of the two kinds is the same. The shafts of the hammers 36 of the repeating cylinders 22 and 23, Figs. 309 and 310, pass through holes in the projecting parts 37 of the

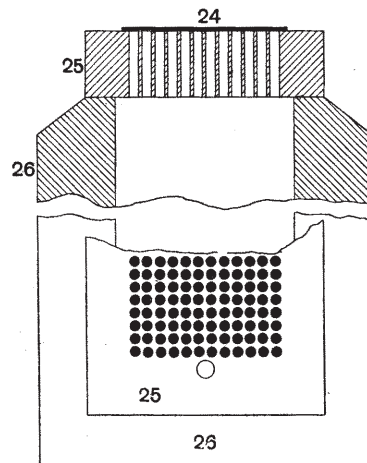

FIG. 312.

bracket 33, and spiral springs 38, with a pin through the hammer shaft, act in the usual way to prevent undue vibration on the part of the cylinders.

Figs. 311 to 316 illustrate the movements of the punches 19 and the method by which they are kept in their positions during the operation of punching. Fig. 311 is a sectional elevation of the punch blocks 20 and 20¹ and the clearing plate 30, with one short row of 12 punches in the inoperative position—that is, in the highest position when the card

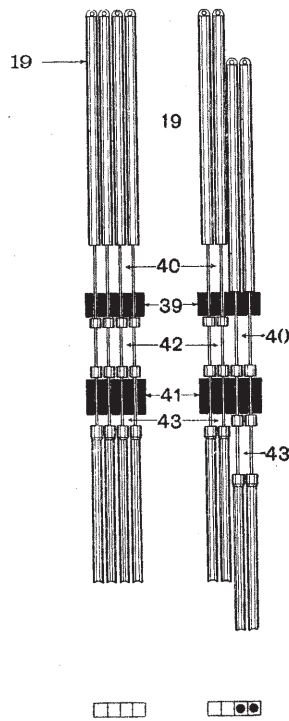

FIG. 313. FIG. 314.

on the cylinder S of the jacquard is making its selection. The upper part of Fig. 312 is a sectional view of the cutting plate 25 and the two sides of the block 26; while the lower part of Fig. 312 shows a plan view of part of the cutting block 25 and part of the block 26. Fig. 313 illustrates four punches 19 out of the long row of 51 (there are really 53 punches in a long row), while Fig. 314 shows that two out of the same four punches have been lowered as already explained. (See the small squares under Figs. 313 and 314.)

It will be seen that each punch (except the extreme end ones, which are not shown) is cut away at three points and at both sides, so that the punches may be the proper pitch for cutting and still leave room between each pair of punches for the insertion of thin rectangular bars or knives. There are two sets of knives; in the upper set the 53 knives marked 39 are fixed in the block, and they pass between the punches 19 in the upper long rectangular gaps 40. The second or lower set also contains 53 knives; these are marked 41, and they are movable in order that they

may enter into the rectangular gaps 43 or 42 between the punches, according as the corresponding punch is up or down.

In Fig. 311 the sliding knives 41 are full out, and quite clear of all the punches 19. This, as already indicated, is a little after the time when the selection of needles and hooks takes place, and the sliding knives 41 remain out until the jacquard griffe is raised, and, of course, until certain of the punches 19 have descended to correspond with those hooks which have been raised in virtue of holes in the jacquard card. The four small squares under the punches in Fig. 314 indicate that Nos. 1 and 2 correspond

to two blanks, while Nos. 3 and 4 correspond to two holes in the card, because the corresponding hooks in the jacquard have been lifted.

The 53 knives 41 are fixed to the rectangular bar 44, and the ends of the bar are attached to the sliding rods 45. The outer end of each rod 45 passes through a guide 46, while the inner or longer part passes through a hole in the block 20. The opposite end of each rod 45 is attached to the connecting links 47, Figs. 303, 305, and 308. A horizontal bar 48 (see Fig. 304 and Fig. 307) connects the two links 47, while the bar 48 is connected as shown to the upper arm 49 of a lever fulcrumed at 50; a cord 51 is attached to the lower arm 52 and passed over a grooved pulley 53, while a weight 54 is fixed to the cord as shown.

Fixed to the lower arm 52, Fig. 303, and a little below the fulcrum 50, is a bracket 55 carrying an anti-friction roller 56. The weight 54 keeps the roller 56 in close contact with the contour of the cam 57 fulcrumed on the main shaft K. It will thus be seen that as the main shaft K rotates, the cam 57 will, through the roller 56, cause the lower arm 52 to move out positively from the dotted to the solid position in Fig. 305, while the weight 54 will pull it back negatively as the face of the cam 57 in contact approaches the thinnest part, until ultimately the arm 52 assumes the dotted position in Fig. 305 and the solid position indicated in Fig. 303.

During these movements the upper arm 49 will reciprocate with the lower arm 52; hence, when the cam 57 has forced the arm 52 outwards to the solid position in Fig. 305, the upper arm 49 will be full in, and the sliding rods, with all connected parts, will be on the extreme left-hand position when viewed from the driving side of the machine. This is the position shown in Fig. 311, with all the knives 41 clear of the slots 42 and 43 in the punches 19, and the jacquard griffe in its highest position. But when the point of the cam 57, Fig. 305, passes the roller 56, the latter moves quickly down the steep face of the cam under the influence of the weight 54 (an action which is just completed in Fig. 303), and hence this action causes the subsequent parts to draw the knives 41, Fig. 311, to the right, in which case they would clearly enter the bottom slots 43, provided that all the punches were in similar positions to that represented by the 12 punches. In the figure none of the 12 punches would project below the face of the clearing plate 30, because the corresponding hooks of the jacquard are all down in response to the blank portion of the pilot card in the set Q, Fig. 303. The blank row in the card which has just operated the needles in the jacquard in Fig. 303 would thus have its counterpart in the corresponding row of the card 24 in Fig. 312. If, however, any of the punches happened to be down—and some would be down in other short rows of the punches—they would appear as shown by the third and fourth punches in Fig. 314, and the knives 41 would then have entered

the middle slot 42 of these punches. The knives 41 would thus prevent the punches 19 from rising when the card 24 on the punch block 25 came

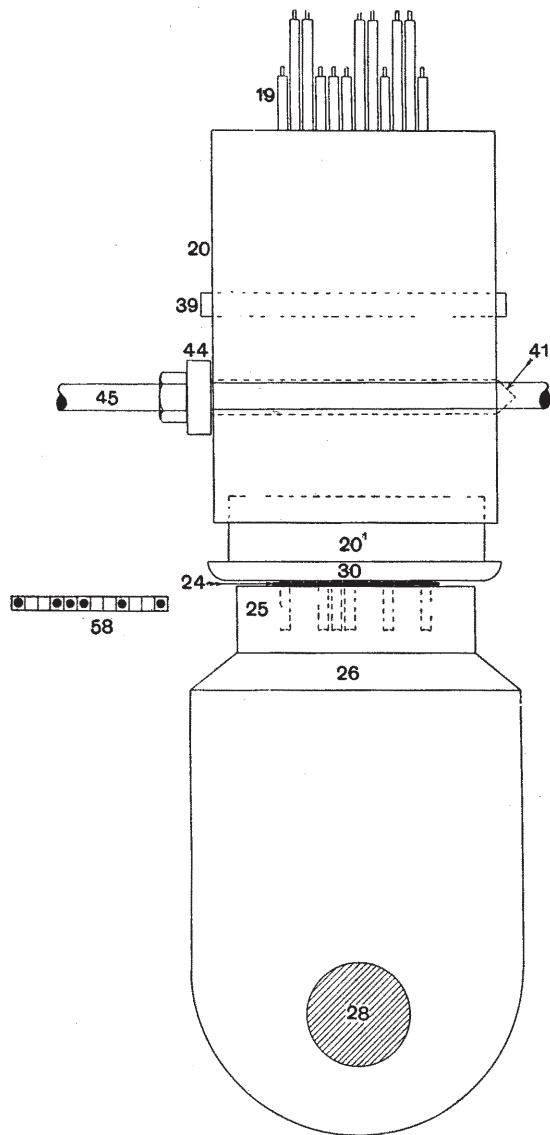

FIG. 315.

into contact with the ends of the dropped punches; hence, the card would be forced upwards beyond the ends of these dropped punches, and the latter would therefore pass through the card as exemplified in Fig. 315.

The single line 58 of 12 marked and unmarked squares on the left of Fig. 315 indicate the positions of the 12 punches in this view; those punches which correspond to the marked squares are shown with their ends through the card 24. In order that the work of punching a complete card may be done with a reasonable consumption of power, it is usual to vary slightly the lengths of the cutting part of the punches; thus, three different lengths of punches may be made, so that the medium-length punches commence to enter the card a little after the longer punches and a little before the shorter punches.

Much enlarged views of the punches, or, rather, the upper part of them, appear in Fig. 316, with the methods of tying the

ords 14 to the punches. In one case, the cord is threaded through a hole in the flat part of the punch, and tied in the usual way; in the other

case, the cord is passed downwards through a vertical hole, then through one of the holes at the side, and a big knot tied on the end ; when this knot is pulled inside the punch as illustrated, it offers no obstruction to the vertical movement of adjacent punches. The upper part of the drawing of the right-hand punch is a section through the hole.

It now remains to show how the card 24 is removed from the ends of the punches 19 when the blocks 25 and 26 descend to the position indicated in Fig. 312. The parts which perform this function are illustrated in

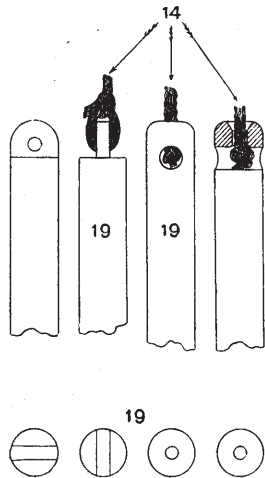

FIG. 316.

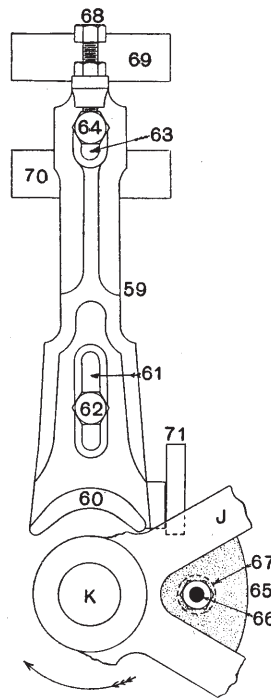

FIG. 317.

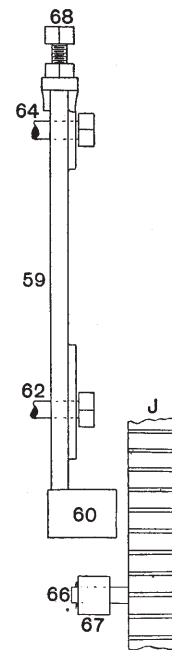

FIG. 318.

Fig. 303, but more particularly in Figs. 317 and 318. On each side of the machine, although not shown in Fig. 306, is a vertical plate 59, to the lower end of which is cast a projecting cam 60. A longitudinal slot 61 is made near the lower end of the plate 59, and through this slot the shaft of a stud 62 passes and is attached to the ends of the bottom block 26, Figs. 307, 308, and 312. A second but shorter slot 63, Figs. 317, 318, and 307, is made near the upper end of the plate 59, through which the shaft of a stud 64 is passed to make a connection with the clearing plate 30, Figs. 308, 310, 311, and 315. The plate 59 is between the frame F and the large wheel J ; part only of the latter appears in Figs. 317 and 318.

In the junction between two of the spokes of the large wheel J is a web 65. A hole through this web serves to carry a stud 66, Fig. 318, upon which rotates an anti-friction roller 67.

When the eccentrics 29, Figs. 307 and 308, commence to raise the block 26, and therefore the stud 62, Figs. 317 and 318, the stud simply moves upwards in the slot 61 until the shaft of the stud 62 reaches the top of the slot; the further upward movement of the block 26 results in the vertical plate 59 being raised along with the similar plate at the other side of the machine. And shortly after the vertical plate 59 commences to rise, the lower surface of the upper slot 63 comes into contact with the shaft of the stud 64, and thus the clearing plate 30 is raised, and ultimately the card is punched.

The further rotation of the shaft K causes the lifting cams or eccentrics 29, Fig. 307, to present their thin surfaces to the block 26, and thus the latter is free to descend. The cutting plate 25 and the clearing plate 30 descend simultaneously with the block 26; the clearing plate, however, sticks, so to speak, because of the tightly fitting punches in the holes of the card, but the cutting plate 25 and the block 26 descend to their lowest positions. Meanwhile, the anti-friction bowl 67, Figs. 317 and 318, rotating with the large wheel J in the direction indicated in the former figure, approaches and finally reaches the left-hand side of the projecting cam 60. As the bowl 60 is approaching the vertical position—*i.e.* above the crest of the upper surface of the cam 60—it is gradually forcing down the cam, so that when the latter, and therefore the plate 59 of which it forms a part, has been forced to its lowest position, the lower end of the stud 68 (see top of Fig. 317) has similarly forced the clearing plate 30 off the ends of the punches, and the ends of the clearing plate then rest on the lower plate 70 until the next upward movement of the plate 59. On the opposite side of the machine, Fig. 307, an anti-friction roller 67¹ on the back of the cam L operates in a similar manner on the cam 60 of the vertical plate 59.

The clearing plate 30 is adjusted and timed by means of the above-mentioned stud 68 and its lock-nut. The two plates 69 and 70 are bolted to the main frame of the machine (see Fig. 303), and a vertical spindle, extending from the upper plate 69 to a point below the lower plate 70, serves as a guide for the up-and-down motion of the cutting and clearing plates, while the lug 71, cast on the side of the frame, serves also as a guide for the plate 59.

If we assume as a starting point the rotation of the large wheel J, Fig. 303, when the jacquard griffe is full up and the cylinder S for the pilot cards Q full out, then the following Tables XIV. and XV. will give the approximate rotation in degrees of the marked point in the wheel J

from the highest position of the point, for the time of the chief actions of the machine :

TABLE XIV
JACQUARD MACHINE

Angle of Rotation of Large Wheel J.	Positions of Various Parts.
360° or 0°	Griffe up, cylinder out.
45°	Griffe commencing to descend, and cylinder starts to move in.
120°	Griffe nearly down, and cylinder in.
150°	Griffe full down.
180°	Griffe begins to move up.
210°	Cylinder begins to move out.
260°	Cylinder just about to turn on to the flat side.
270°	Cylinder on the flat side.
310°	Cylinder full out and griffe nearly full up.
310° to 360°	Very slight movement of griffe.

TABLE XV
REPEATING MACHINE

Angle of Rotation of Large Wheel J.	Positions of Various Parts.
360° and 0°	Feed and delivery cylinders 22 and 23 stationary ; sliding knives 41 full in ; punching blocks 25 and 26 commence to rise.
60°	Punching plate and card 24 reach the clearing plate 30.
100°	Punches 19 ready for cutting holes in the card.
150°	Card punched with both plates full up ; both plates commence to descend.
160°	Punching plate 25 moving away from punched card and clearing plate.
175°	Small anti-friction roller 67 commences to act on the cam 60 of the vertical plate 59.
180°	Cam 57 operating on levers and arms to force sliding knives from slots in the punches.
200°	Clearing plate forces punched card off the ends of the punches.
270°	Sliding knives commence to move inwards into the slots.
300°	Sliding knives full in ; punching plate and block reach lowest position, and commence to rise again.

It might just be stated that the laced cards which are to receive the impressions or holes identical with those on the pilot chain Q, Fig. 303,

are placed under the lingoe box 13 and on the floor. The end of the chain is then passed behind a roller and led up to the feed cylinder 22, under the punches 19 and clearing plate 30, over the delivery cylinder 23, and finally over rollers to be delivered on to the floor after each card has been cut according to pattern. The discs of card which are punched ultimately leave the cutting plate 25 and drop into the wooden box 71.

Fig. 319 illustrates the delivery and balance-wheel sides of a machine made originally by Messrs. William Ayrton & Co., Manchester. The cards

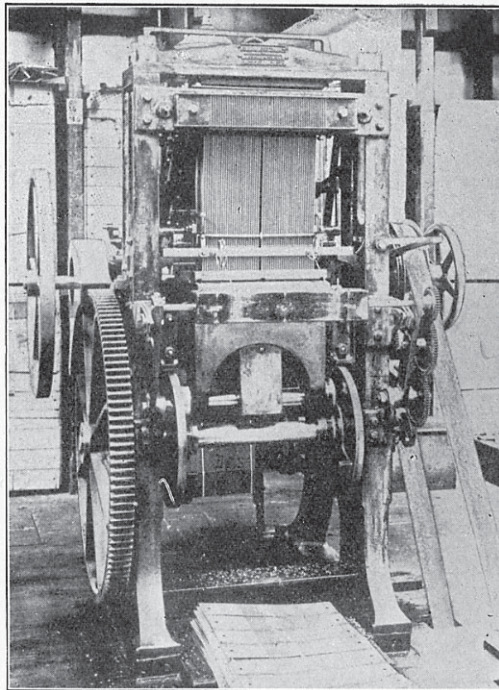

FIG. 319.

from the delivery cylinder were removed in order that the cylinder might be seen quite clearly; the box for catching the punched-out discs of cardboard which drop through the converging conductor 58, Fig. 321, was also removed from its position, so that the main shaft M and the large plate cams 32 could be exposed to view. In Fig. 320, however, which is exhibited mainly to show the pulley side of the machine and the train of wheels for conveying motion to the two cylinders over which the cards to be repeated are passed, the set of repeated cards is in position, and so is the above-mentioned box. This view

also shows the pilot set of cards on the right or feed side of the machine.

One distinctive feature about this machine is that there are no cords required for operating the punches, since the needles of the pilot jacquard control directly the upper part of the punches, or rather the rods which act upon the actual punches. The drive is by means of cones, and in this case an underground shaft supplies the power to the machine, illustrated in Fig. 320, as is clearly shown by the belt. In Fig. 321, which is a line drawing of the delivery side of the machine, the flanged belt pulley A is recessed as indicated to fit the cone B on the driving shaft C. On

the same shaft C, and outside of the belt pulley A, is fixed the hand-wheel D. The cone B is placed in and out of contact with the recessed part of the pulley A by means of a clutch E operated by a hand lever F. The hand lever F is kept in the inoperative position—that shown in Fig. 321—by means of the latch G, so that the latch must be lifted before the handle F can be moved to place the cone B in contact with the inner inclined surface of the driving pulley A.

The pulley shaft C extends to the other side of the machine, where at the extreme end of the shaft is a heavy balance-wheel H, whilst between this balance-wheel and the substantial frame J is a pinion K which drives the large wheel L on the main or cam-shaft M.

Returning to the delivery side in Fig. 321, the two lifting cams 2 are shown in their proper positions on the heavy main or cam-shaft M, with the thin parts of the cams 2 in contact with the anti-friction rollers 3, and hence the latter are in their lowest position. The anti-friction rollers 3 are carried by the shaft 4, and the latter controls the up-and-down movements of the lifting and punching block 5. The cards are “repeated” or punched, one full card at a time, between the lower punching block 5 and the upper plate 6, one card 7 being in position in Fig. 321.

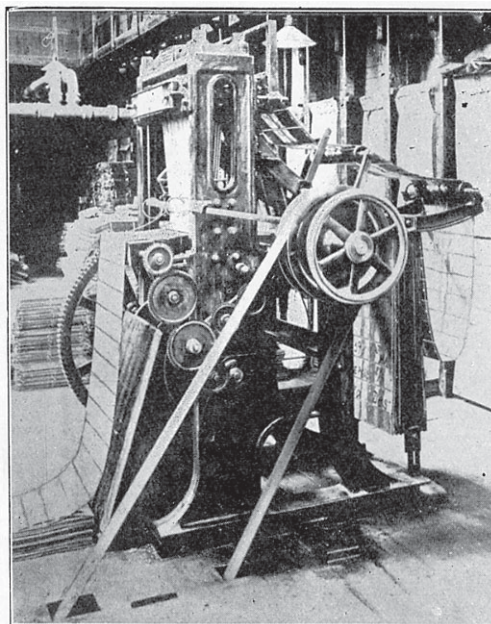

FIG. 320.

The shaft M is also seen in Fig. 322, which illustrates an end elevation of the balance-wheel end, and the method of feeding the pilot set of cards N. This set of cards, which will have been punched in an ordinary piano machine, laced in one or other of the usual ways, and then wired, is placed in the card cradle O, Fig. 322. The inner ends of the card cradle are secured to two projecting brackets P on the main upright frames J.

One end of the laced set of cards N is led around roller Q, over and under rollers R and S supported by suitable brackets, over the cylinder T, and finally back to the card cradle O, where it is joined to the other end

if necessary to form a closed chain. The card wires U enable the cards to depend to the desired depth; in the case illustrated the wires are attached at intervals of 12 cards, which represent 12-row cards for a 600's jacquard.

The action of the jacquard needles and supplementary parts will be

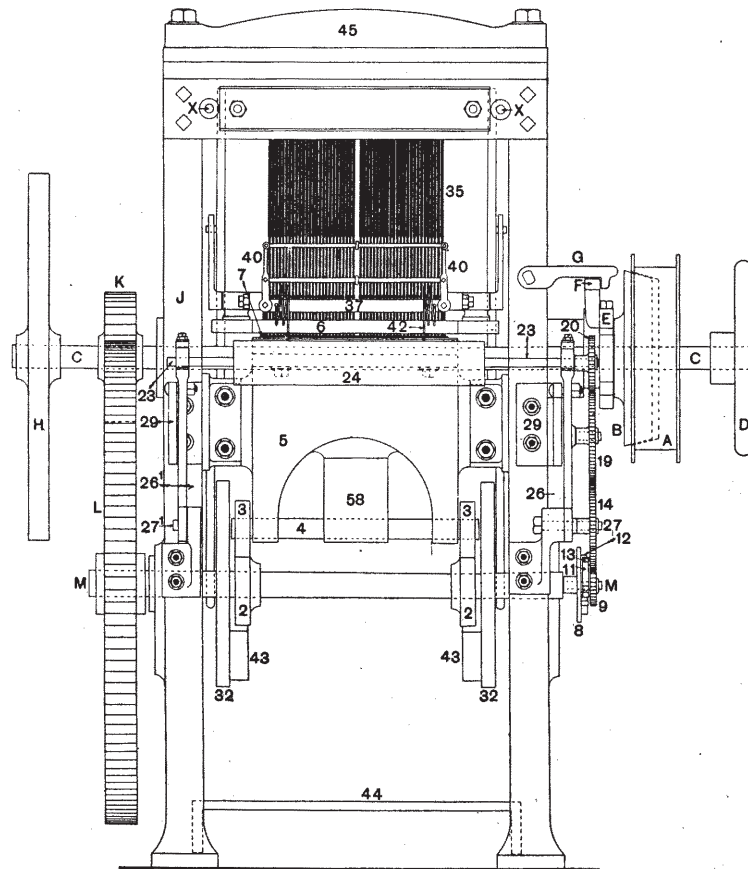

FIG. 321.

described in a sectional view; in the meantime it will be observed from Fig. 322 that there is the usual form of catch V to act on the lantern W of the cylinder T, and so turn the latter one-quarter clockwise as the slide rods X move out under the influence of the collar Y and other mechanism which will appear in the sectional views. A second catch Z may be raised in contact with the underside of the lantern W, and held there by means of a spring attached to any convenient part of the cylinder frame, when it

is desired to rotate the pilot cards N and the cylinder T counter-clockwise, as in symmetrical patterns; in such cases the upper catch V is obviously raised clear of the cylinder lantern.

The shaft M, Fig. 321, extends across the machine, and at the end which projects outside the frame on the pulley side is reduced to take

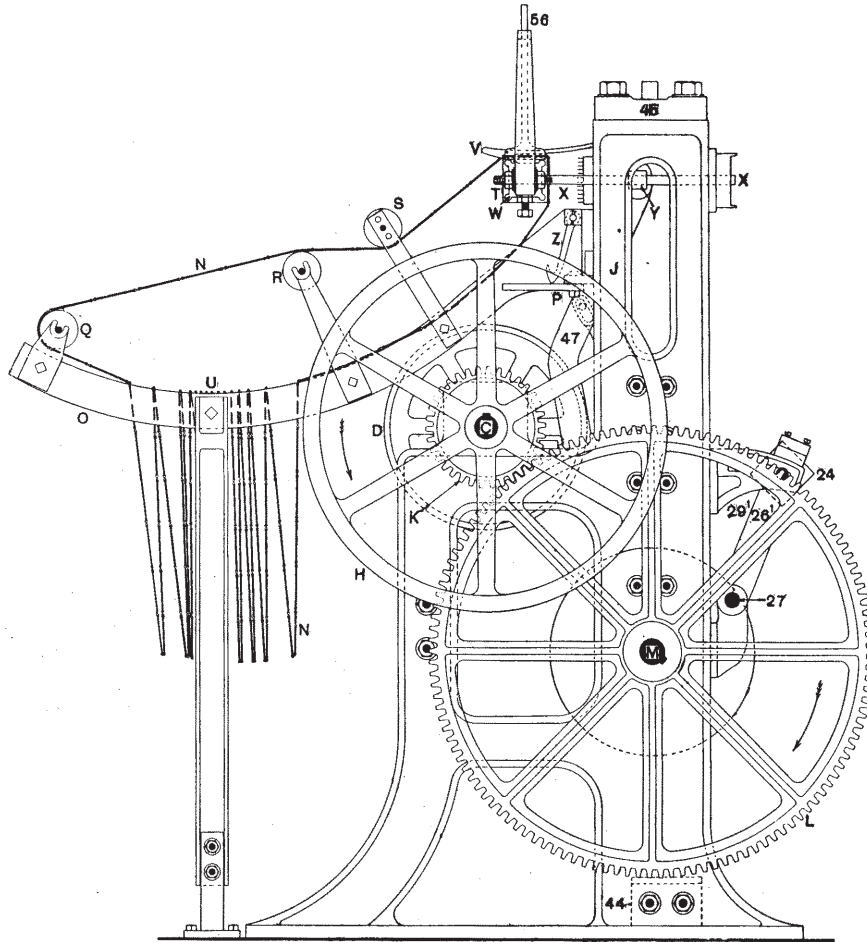

FIG. 322.

the bead and peg disc 8. (See also the elevation of the pulley side in Fig. 323.) The bead and peg disc works in conjunction with the star-wheel 9. As the shaft M rotates, Fig. 323, the bead 10 of the disc 8 runs on one of the curved parts 11 of the star-wheel 9; but when the end of the bead 10 passes the edge of the curved part 11, the peg 12 of the disc 8 enters the

slot 13 of the star-wheel 9 and turns the latter one-quarter of a revolution. The star-wheel 9 thus rotates intermittently the two trains of wheels 14, 15, 16, 17, and 18, and 14, 19, and 20. The bead and peg disc rotates counter-clockwise in Fig. 323, and since there are odd numbers of wheels between it and the two wheels 18 and 20—*i.e.* 5 wheels in the first train and 3 wheels in the second train—the wheels 18 and 20 will also rotate counter-clockwise. Wheel 18 is on the shaft 21 of the feed cylinder 22, while wheel 20 is on the shaft 23 of the delivery cylinder 24.

The two trains of wheels for driving the feed and delivery cylinders counter-clockwise, when viewed from the pulley side in Fig. 323, are supported by arms 25 and 26, both fulcrumed in the stud 27, which carries the wheel 14 common to both trains of wheels. Suitable brackets from the arms 25 and 26 form supports for the wheels; some of these are shown distinctly in Fig. 321, and so is the companion arm 26¹ on stud 27¹ supporting the other end of the shaft 23 of the delivery cylinder. The slot 28 in bracket 25, Fig. 323, provides means for altering the position of the shaft 21 of the feed cylinder 22, while the slots in the two brackets 29 provide similar means for the adjustment of the shaft 23 of cylinder 24. An adjustable bracket, with the two holes in different planes for the shafts of the feed cylinder 22, supports the latter at the balance-wheel side of the machine, while a somewhat similar provision is made for the shaft immediately behind wheel 18, Fig. 323. Since no compound-wheels appear in the trains of wheels to the cylinders 22 and 24, and since wheels 9, 18, and 20 contain each 40 teeth, it follows that, each time the star-wheel 9 is moved by the peg 12 of the disc 8, each of the above-mentioned three wheels will be moved 10 teeth, or one-quarter of a revolution.

The cards 30, Fig. 323, which are being punched, move in the direction of the arrow, and are guided by roller 31 to the feed cylinder 22 as demonstrated in Figs. 324 and 326, which, with Figs. 325 and 327, illustrate sectional views of some of the chief parts of the machine.

In Fig. 324 the lifting cam 2 on the main shaft M is in its lowest position, and so is the anti-friction bowl 3 and the lifting-block 5. The large plate cam 32 (see Fig. 321 for the position of this and its companion disc) is described later, or at least the opposite side of the disc to that shown in Figs. 324 and 326. In Fig. 326 the cam 2 and the connecting parts are in their highest positions. Both blocks 5 and 6 are raised at the same time to the position indicated in Fig. 326.

All the needles 33, Fig. 324, are full out (one short row only is shown), and they would still remain in their present positions if a full row of holes—say 12, as indicated above the cylinder T at 34—came opposite them with the next inward movement of the cylinder. Consequently all the rods 35, which are the equivalent of hooks in the ordinary jacquard

machines, would remain as illustrated. And if the block 5 were to rise, all the punches 36 in the upper block 37 would be raised ; and since their upper parts are cup-shaped as illustrated on a very large scale in Fig. 327, the rods 35 would be raised, and their upper ends would be arrested by

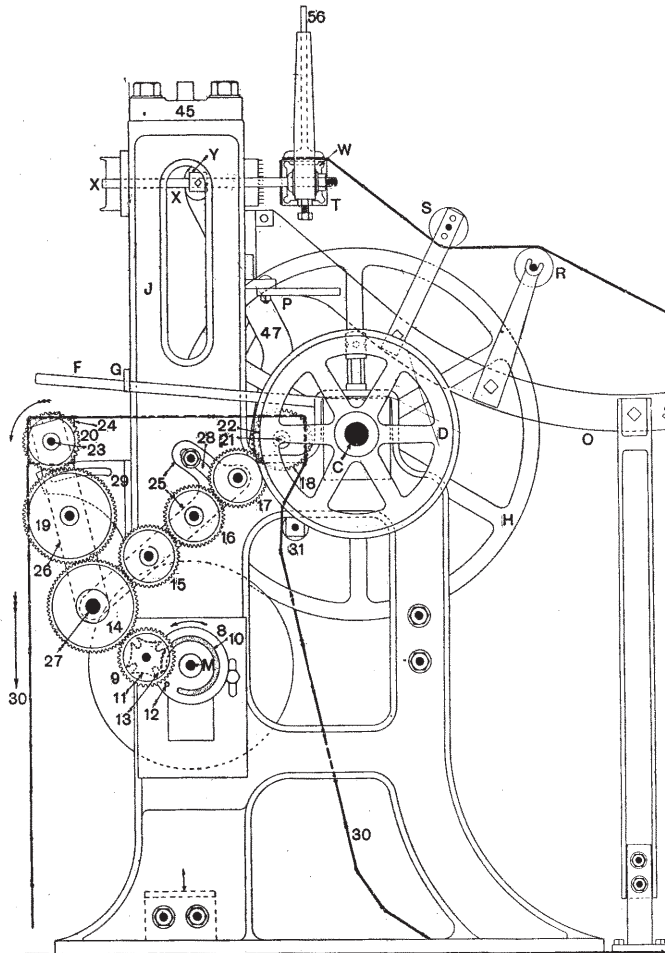

FIG. 323.

the stationary griffe or brander 38, Fig. 324, before the lifting block 5 reached its highest position ; hence, the cutting surfaces at the lower end of the punches 36 would pass through the card which at the moment happened to be between the plates 5 and 6.

If, on the other hand, a card with holes and blanks on the same line as

at 39. Fig. 326, should be presented to the needles 33 as depicted in that figure, those needles opposite the places corresponding to the blank squares in 39 would be pressed back as indicated, and, when the block 5 lifted the punches 36 and the rods 35, those rods which had been pressed back by

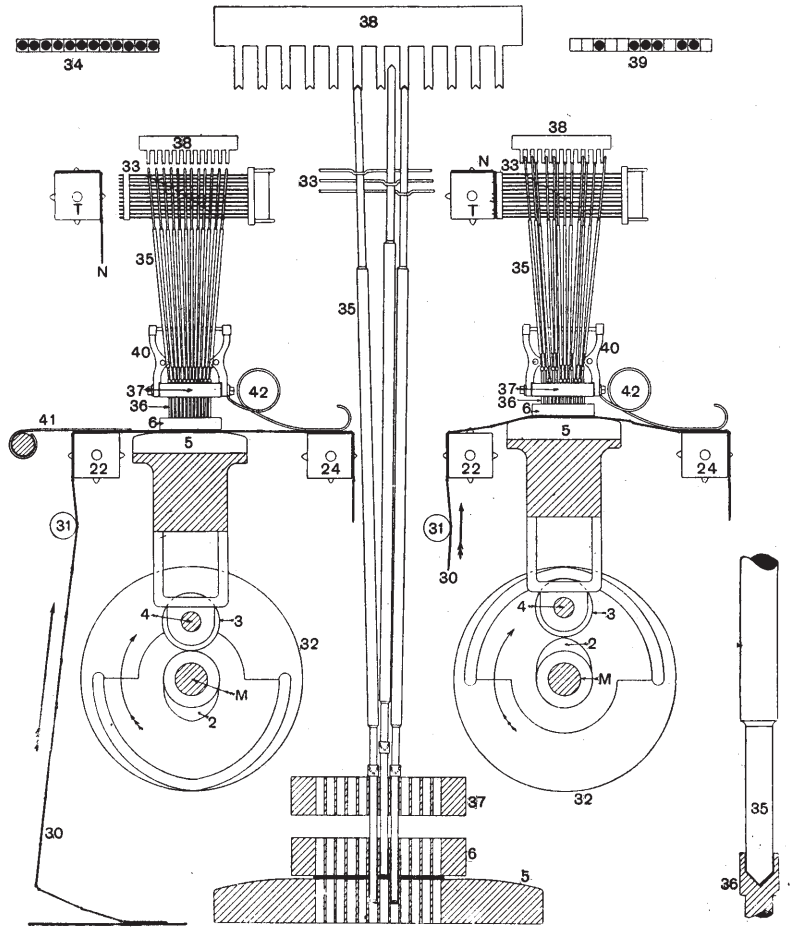

FIG. 324.

FIG. 325.

FIG. 326.

FIG. 327.

the needles would enter the gaps between the depending arms of the stationary griffe 38, while the remainder would come in contact with the Λ -shaped ends as explained, and thus the line on the card between the plates 5 and 6 would correspond to the line 39.

An enlarged view of three needles, three rods, and three punches appears in Fig. 325. The two outside rods are in contact with the depending arms of the griffe, and their punches are through the card, whereas the middle