

rod is free—having been pressed back—and its upper end is in one of the gaps of the griffe, because its punch has simply raised it, as demonstrated, due to the blank or uncut part of the card between the plates 5 and 6. All the punches are guided in a true vertical movement by the holes in the upper fixed block 37; the middle block 6 rises with the lower one.

The rods 35 are contained in a skeleton frame 40 composed of suitably shaped vertical bars and round horizontal rods, while springs 41 and 42, the former a straight one for the feed cylinder 22 and the latter coiled for the delivery cylinder 24, serve to keep the cards in their proper positions. The bead 43, Fig. 321, on the disc 32 would force the bowls 3, and therefore the block 5, downwards if the latter showed any tendency to stick.

The reverse side of plate cam 32, as compared with Figs. 324 and 326, is exhibited in Fig. 328. The outer and narrower box cam is not now used, but the function of the inner and broader box cam (both are in solid black) is demonstrated in Figs. 329 and 330. Both views are partly diagrammatic, and yet the parts are very similar to the actual parts in the machine; and both views are of the inside of the frame in the lower parts. The broad rail which bridges the gap between the two upright frames J is shown at 44; the heavy upper cross rail 45 is fixed to the same uprights as shown. The inner and broader cam only in Fig. 328 is reproduced in solid black in Figs. 329 and 330, and 180 degrees separate the two positions.

An anti-friction roller 46 rotates freely in the box cam of disc 32, and thus imparts a to-and-fro movement to the lever 47, fulcrumed at 48. The upper part of the lever is bent, as shown, and at the extreme upper end carries a pin or stud 49 which enters a vertical slot in the bush Y of the slide rod X for the cylinder T. As the shaft M rotates from the position indicated by the parts in Fig. 329 to that shown in Fig. 330, the lower arm of lever 47 is moved to the left and the upper arm to the right, and hence the cylinder T and the card are brought into contact with the needles

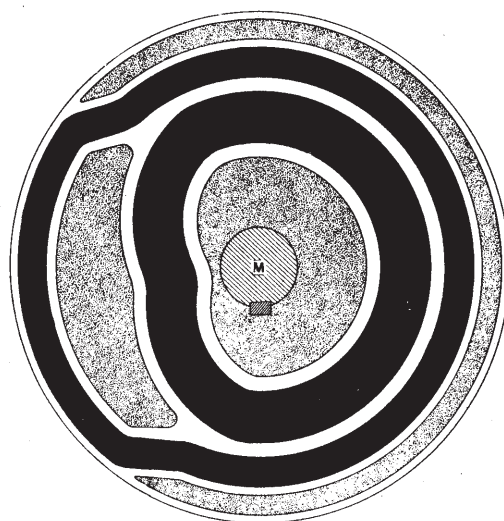

FIG. 328.

projecting through the needle-board 50. Conversely, during the following half-revolution of shaft M and disc 32 the cylinder is moved outwards to the position shown in Fig. 329.

As the cylinder T and card are approaching the needle-board, and the punching or lifting block 5 is moving upwards to punch the card between the blocks 5 and 6, it is desirable and essential that the card should occupy its exact position with regard to the blocks 5 and 6. A pin 51 is situated in the slot of the longer arm of the bell-crank lever 52, while the shorter arm of the lever controls a part 53 with a vertical pin 54. This pin 54 enters the peg-holes of the card 55 during the above movement, so that the card is held securely in position during the operation, as exemplified in Fig. 330.

The catch Z, Fig. 330, is shown in position for reversing the direction of the cards, and the usual spring hammer 56, with the spiral spring around its upper shank, is clearly seen. A 600's or 12-row cylinder is in position in Fig. 330, but a 400's or 8-row cylinder T is shown in Fig. 329. An 8-row card 55 is also in the cutting position. When it is necessary to repeat an 8-row set of cards, the two upper long rows and the two lower long rows of needles are covered with the angular plates 57, Fig. 329. It is also necessary to introduce similarly sized cylinders instead of the 12-row ones illustrated at 22 and 24 in Figs. 323, 324, and 326, and to make adjustments on the arms 25, 26, and 29 in the former figure. Six 12-row cards bridge the gap between the cylinders 22 and 24 in the above illustrations, but eight 400's or 8-row cards are required.

The feed side and driving end of the jacquard card repeating machine, made by Messrs. James M'Murdo, Miles Platting, Manchester, are illustrated in Fig. 331. This machine, as well as those which have already been illustrated and described, is for repeating ordinary pitch jacquard cards. An illustration of the delivery side and the opposite end to the driving of a very similar machine, made by the same machine-maker, appears in Fig. 332. It will be noticed that the upper parts of the two machines are almost identical, but the lower part of the framework of the machine shown in Fig. 332 is of a heavier build than the corresponding part of the frame in Fig. 331.

As in the other machines, that illustrated in Fig. 331 is adapted for cutting 8-row and 12-row cards of the usual 400's and 600's types. On the other hand, the machine illustrated in Fig. 332 is of more modern type, having just been introduced by Messrs. James M'Murdo, and has been designed for the repeating of cards of a much finer pitch. Otherwise, the illustrations are typical of the two ends, feed and delivery sides of the ordinary pitch repeater made by the above firm.

The difference between the actual cutting parts and the adjacent

mechanism will be understood by reference to Figs. 333 and 336, which illustrate details of the punch, and complete views of punches, hooks and connections, and locking knives. Fig. 333 shows the fixed and moving blocks A and B, the fixed knife C, the moving, sliding, or locking knife

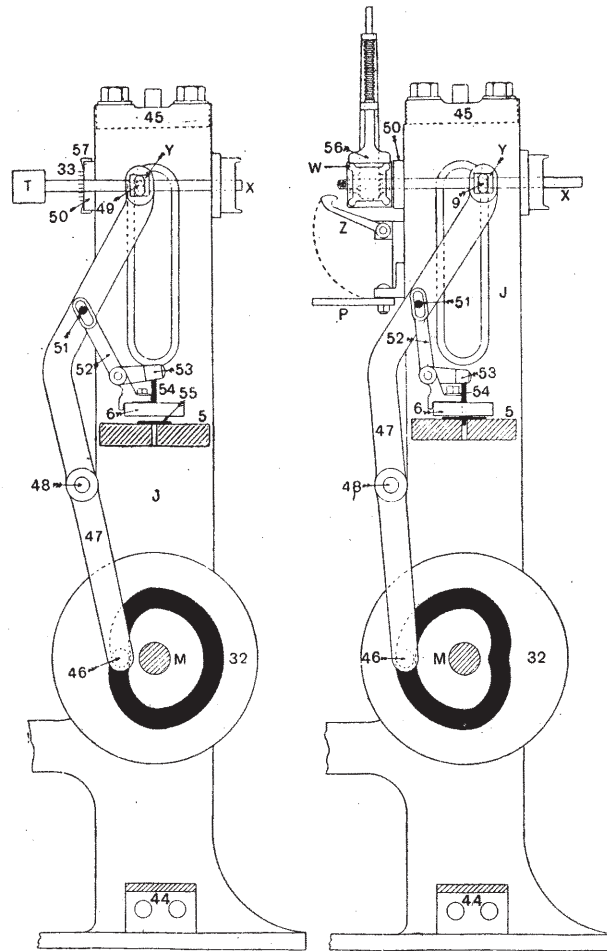

FIG. 329.

FIG. 330.

D, with the bell-crank lever E which operates the knife D. The bell-crank lever E is fulcrumed at F. The short arm of the lever E is raised by the cam G, which rotates with the main shaft H. As the latter rotates in the direction indicated by the arrow, the short arm of lever E will rise, and the long arm will move to the right and withdraw the locking knife D.

In the present view, the locking knife D is full in, and in the position essential when the actual operation of punching a card is taking place.

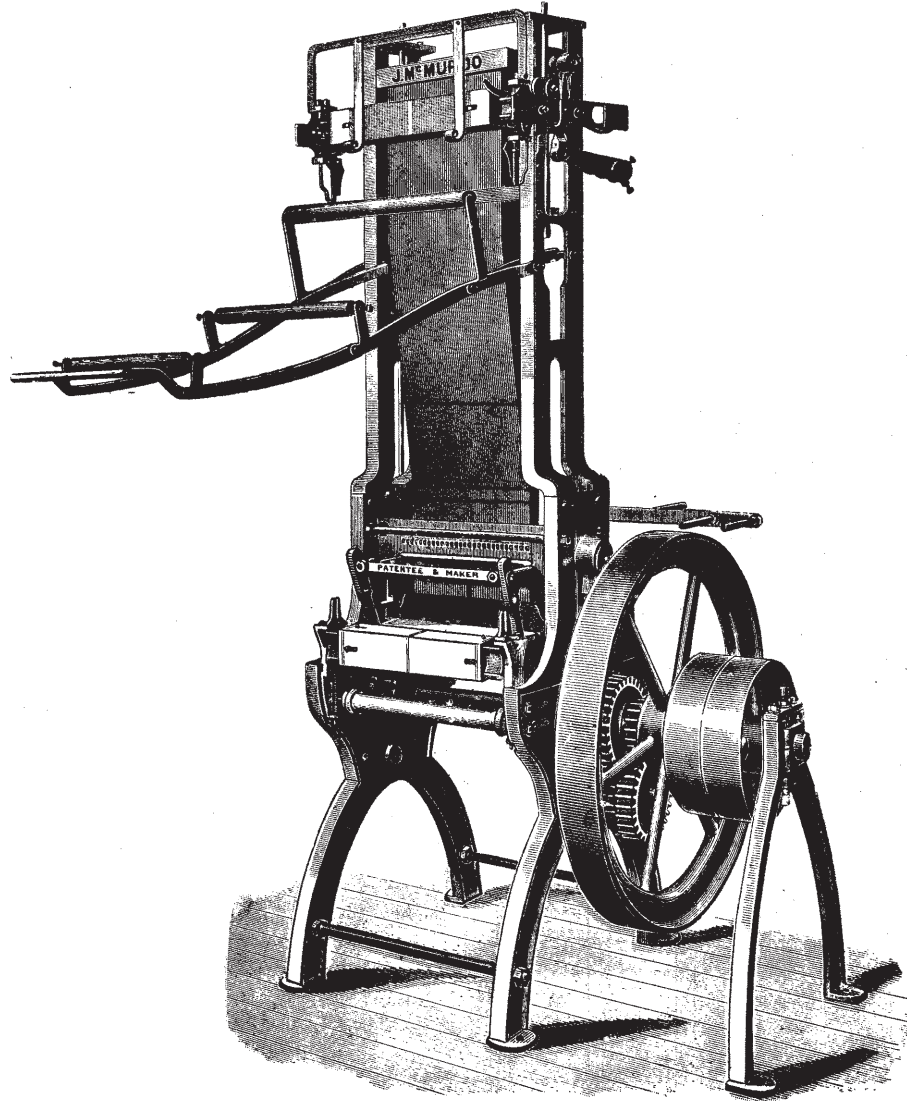

FIG. 331.

The view in Fig. 333 shows that there are twelve punches J, and therefore the illustration shows one short row of the ordinary card repeater for 600's cards; it can, of course, be made suitable for punching 500's and

400's cards, and for any other with fewer punches than 600's, provided the length of the card is the same as those for the ordinary 600's cards.

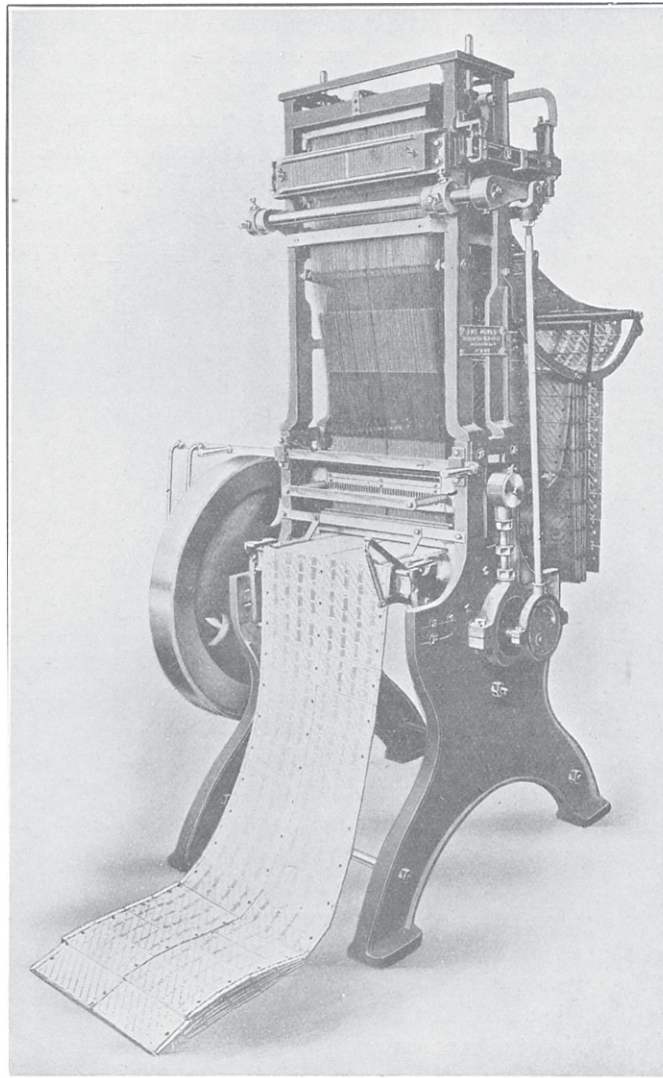

FIG. 332.

The five punches J in Fig. 334 are also representative of the punches for the ordinary pitch repeater, but they are drawn to a larger scale than the parts in Fig. 333; they are drawn one-tenth the actual size, and so

is the single punch J^1 in Fig. 334. All the connections for this punch are also shown up to the knife, but the punch itself has been drawn 90° round, instead of in its actual position, in order that the shape might be more clearly shown. It will be seen that the punch J^1 , Fig. 335, is much smaller than, although exactly the same length and shape as, the punches J , Fig. 334, also marked 1, 2, 3, and 4 on the right. The punch J^1 and the attached parts in Fig. 334 are for the medium pitch repeater.

The difference between the two pitches is perhaps better illustrated in the two parts of cards at the bottom of Fig. 336. Both cards are the same in width, so that 16 holes in the medium pitch card occupy the same width as 12 holes in the ordinary pitch card, and the same proportions obtain in the length. In the 600's ordinary pitch card, $16\frac{1}{4}$ in. \times $3\frac{1}{2}$ in., there are

$$\left. \begin{array}{l} 26 \text{ rows} \times 12 \text{ holes} = 312 \\ 25 \text{ ,,} \times 12 \text{ ,,} = 300 \end{array} \right\} = 612 \text{ holes ;}$$

while in the above-mentioned medium pitch card, termed a 1350's, $19\frac{1}{8}$ in. \times $3\frac{1}{2}$ in., there are

$$\left. \begin{array}{l} 1 \text{ part row} \times 12 \text{ holes} = 12 \\ 41 \text{ rows} \times 16 \text{ ,,} = 656 \\ 2 \text{ part rows} \times 12 \text{ ,,} = 24 \\ 42 \text{ rows} \times 16 \text{ ,,} = 672 \\ 1 \text{ part row} \times 12 \text{ ,,} = 12 \end{array} \right\} = 1376 \text{ holes.}$$

And since the same kind of cardboard can be used in both machines, it follows that with any constant sett or porter about half the weight of cards will be used for the medium pitch repeater and jacquards as compared with the weight used for the ordinary machines.

A sectional view of the punching plates and blocks is introduced in Fig. 337. This view shows provision only for 8 punches J of the ordinary pitch—a sufficiently large number for descriptive purposes. It will be understood, however, that in this repeater there are 12 punches in each short row, as indicated in Fig. 333 and by the upper card in Fig. 336; in the medium pitch repeater there are obviously 16 punches per short row, and of the size indicated by that marked J^1 , Fig. 335. The punches in Fig. 337 are drawn one-fifth the full size, and are therefore twice the dimensions of the hooks J , Fig. 333.

Before describing the manipulation of the punches, it might be advisable to consider the full complement of parts up to the jacquard machine which carries the pilot set of cards to be duplicated. In principle, as already stated, the medium pitch punch J^1 is the same as those of the ordinary pitch; indeed, it differs from them only in the diameter of the steel. Hence, any description having reference to the ordinary pitch punches is applicable to the medium pitch punches.

The jacquard machine, the position of which will be indicated later, contains 12 ordinary lifting knives, one of which is shown at K in con-

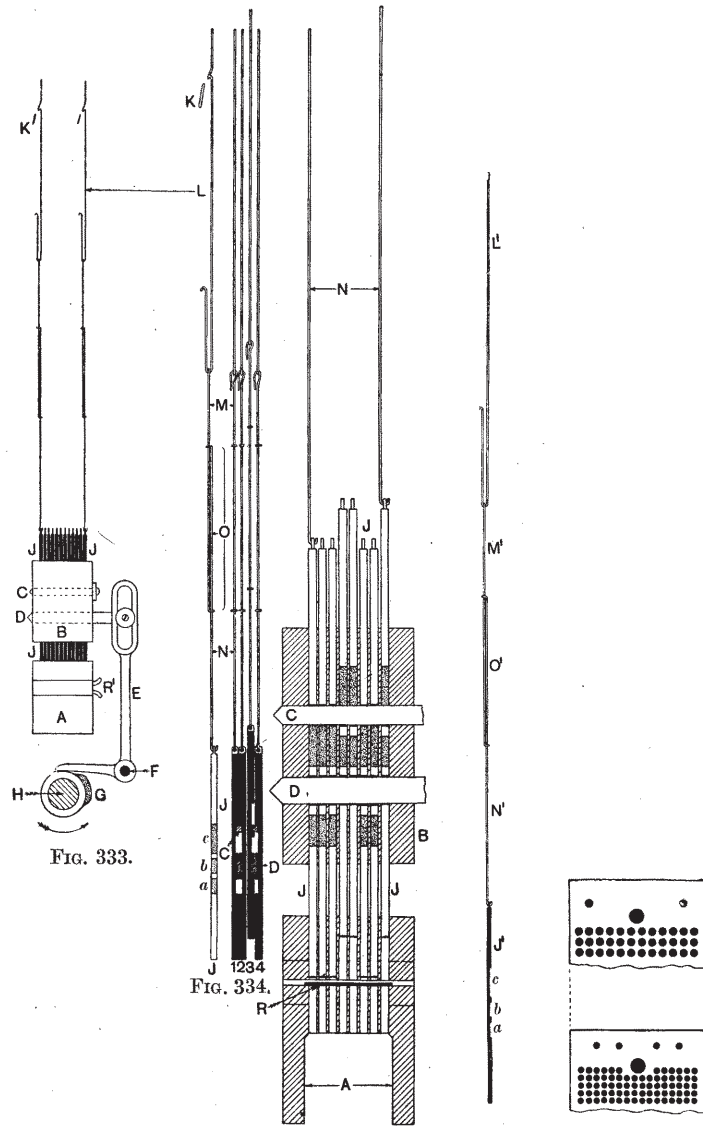

nection with the first punch of the 5 in Fig. 334. The upper part of the hook or upright L for the ordinary pitch machine differs slightly from the medium pitch upright L, Fig. 333. Narrow knives K are used for the

ordinary pitch jacquard, but deep knives are used for the medium pitch machine.

To the bottom bent part of the hook L is attached a wire M, as indicated in Fig. 334; the bent lower end of the wire M is provided with a hole through which the lower wire N passes, and the latter in turn has a similar bend at the top through which the wire M passes.

Encircling the upper part of wire N, and extending the distance marked O, is a fine-wire spiral spring. The hooked end of the wire N is finally attached to the punch J, and this completes the equipment. The normal position of the hook L is off the knife K, and not on, as is usual with ordinary jacquards.

Each punch has three sections cut away to form recesses, as shown in Fig. 334, on the punches J—also marked 1, 2, 3, and 4—and the corresponding parts *a*, *b*, and *c* are shown stippled on the adjoining punch J, which is set 90° further round than the four punches. The cut-away portions are also shown clearly in Fig. 335. The two lower recesses in Fig. 334 are $\frac{3}{4}$ in. deep, while the upper section is $1\frac{1}{2}$ in. deep, all cut half-way through the diameter of the punches.

Along the full 52-row width of the machine these punches are arranged in pairs, the cut-out recesses of each facing each other as clearly indicated. When the jacquard griffe is down, and the selection of needles is taking place, all the punches are in their lowest positions, as shown in Fig. 333. Holes on the pilot cards have no effect on the needles nor on their corresponding hooks L; hence the hooks and all attached parts will remain in their lowest positions, and as indicated by punches 1, 2, and 4, Fig. 334. On the other hand, a blank at any point on the pilot card would act on the corresponding needle, and the latter would push its hook over the knife K, in which case all attached parts would be lifted, and the punch would take up the position shown by punch 3.

It has already been stated that there are two knives in the punching block—a fixed one C and a locking one D. The ends of the 26 fixed knives C—each knife controls two punches—are shown in the elevation of the feed side in Fig. 338; the ends of the locking knives D are not shown, but they are immediately behind the plate D¹, and the latter is attached as exemplified to the upper arms of the bell-crank levers E.

When the selection of needles is taking place—*i.e.* when the jacquard cylinder P and the pilot card are in close contact with the needle board Q (see Fig. 339)—the levers E and the locking knives D will be full out, as indicated by the positions marked E¹ and D¹, Fig. 339, so that all selected punches are free to rise. Those hooks L which have been pushed by their needles over the knives K will be lifted, and the corresponding punches raised to the height represented by punch 3, Fig. 334. This action will

place the recess *a* of punch 3 to the same level as recess *b* of the unaffected punches 1, 2, and 4; the long recess *c* enables this to be done in spite of the position occupied by the fixed knife C, which serves to keep all recesses

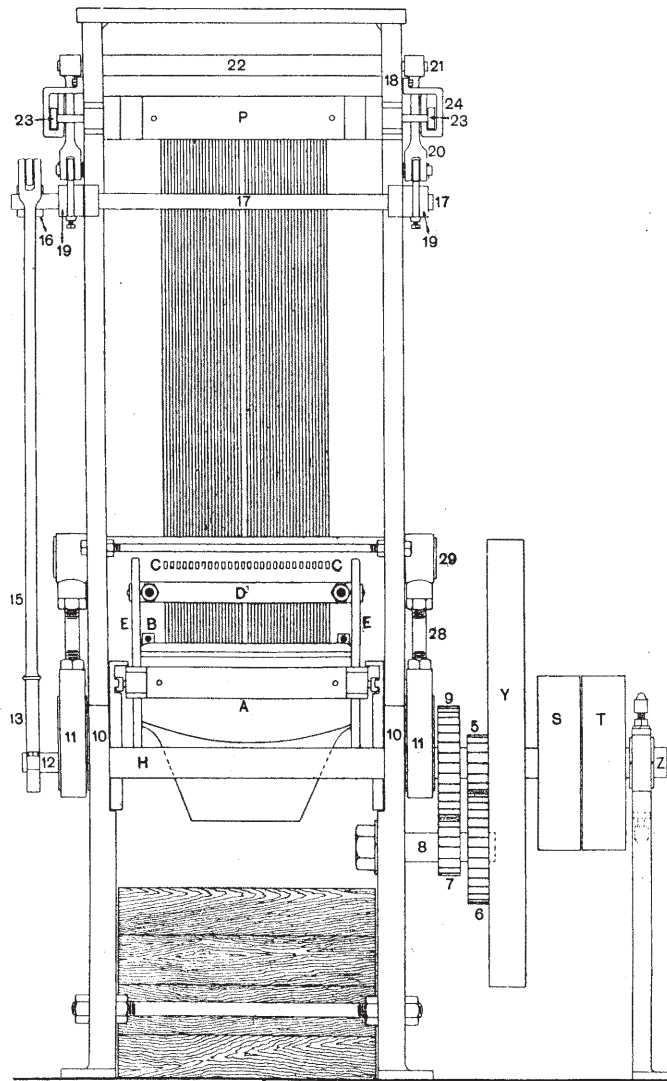

FIG. 338.

a, *b*, and *c* clear for the knives to enter and leave. It will thus be seen that when the jacquard griffe carries up the knives, and the cylinder P is moved by the swan-neck (not shown) to the outer position as shown in Fig. 340,

the recesses *a* of all lifted punches *J* and the recesses *b* of all unaffected punches *J* will be in the same horizontal plane, and ready to receive the

26 locking knives *D* as the latter are moved forward under the influence of the parts illustrated in Fig. 333. When these movements have been effected, the parts will be placed as are illustrated in the sectional view in Fig. 337, and the card *R* to be punched will be in position over the holes in the bottom punch block *A*.

All the punches *J* are thus clear of the card—an essential condition when the latter is being drawn forward under the punches—but it will be observed that punches 4, 5, and 8, Fig. 337, are pretty high up in the upper block *B*, whereas punches 1, 2, 3, 6, and 7 are just sufficiently raised to allow freedom of movement as the cards are entered between the blocks at *R*¹, Fig. 333, and when they are being withdrawn after the punching operation is completed.

The machine is usually placed in and out of action by means of fast and loose pulleys *S* and *T*, and a belt guided by the belt fork *U*, Figs. 339 and 340,

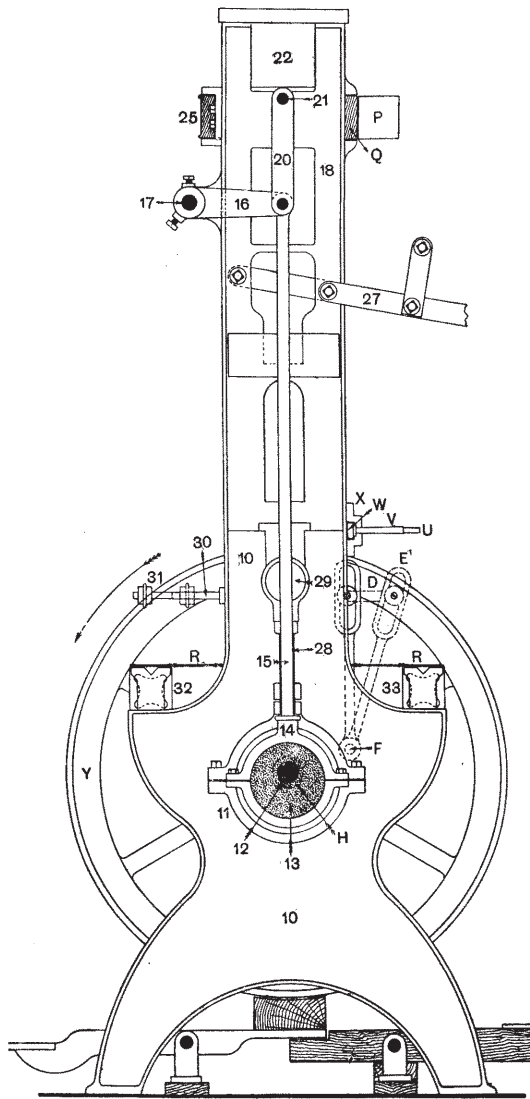

FIG. 339.

and operated by the handle *V* on the bar *W*, which can be slid in the brackets *X*.

The pulleys *S* and *T*, and the balance-wheel *Y*, Fig. 338, are on the

shaft Z, and so is the driving pinion 5 of 30 teeth. The pinion drives the wheel 6 of 60 teeth compounded with pinion 7 of 30 teeth on stud 8, and pinion 7 drives wheel 9 of 60 teeth on the main shaft H. This shaft, as shown in Fig. 338, extends through the machine, and near each end and immediately outside of the substantial frame 10 is placed an eccentric and strap 11, Fig. 339. Finally, the end of the shaft H is turned down to the diameter at 12, as shown in Fig. 338, and a smaller eccentric 13 secured to it.

The strap 14 of the small eccentric 13 is connected with the rod 15, and the latter in turn to the lever 16 fulcrumed on shaft 17, which extends to the other side of the jacquard 18. Near the outside frames of the jacquard, and fixed on the shaft 17, are two other levers 19, the ends of which are connected to links 20, and these links to studs 21 on the ends of the lifting griffe 22. The slide rods or bars 23, Fig. 338, support the pivots of the pilot cylinder P, and the rods 23 slide in the brackets 24 under the usual influence of the griffe 22 and a swan-

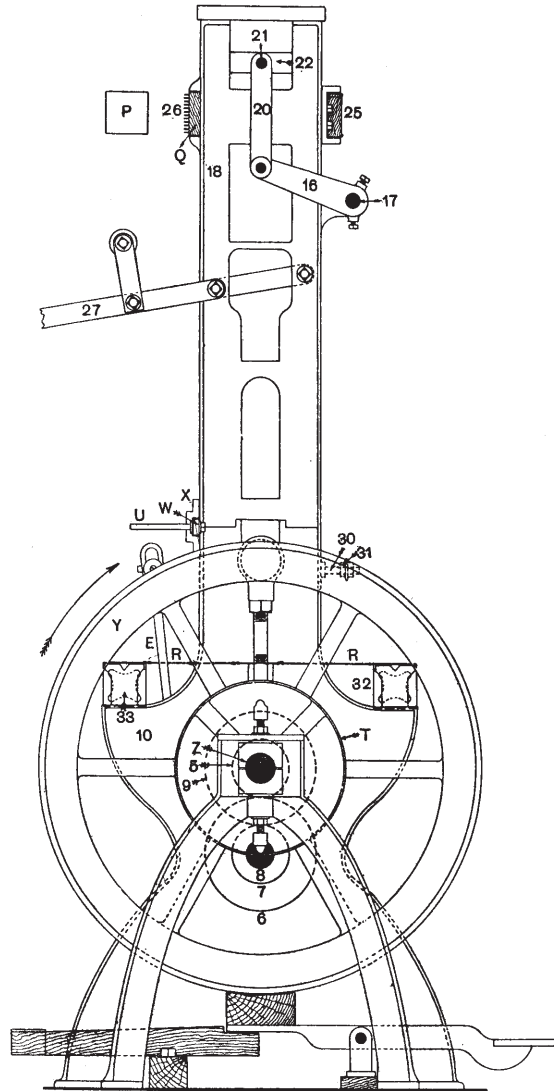

FIG. 340.

neck. These parts are not shown in the end elevations in Figs. 339 and 340, since these parts are subsidiary in this case to the punching and selecting mechanism; and in Fig. 340 the cards R

are shown full for clearness, although they are obviously inside the frame 10.

The customary spring-box 25 is provided, and the needles 26, Fig. 340, are acted upon in the usual way by cards which pass over the cylinder P from the card cradle 27; part only of the latter is shown in the line drawings, but two types of cradles are shown quite distinctly in Figs. 331 and 332. The two eccentrics are also prominent in the latter figure.

The straps of the large eccentrics 11, Figs. 338 and 339, are connected by the rods 28 to studs 29 projecting from the sides of the upper block B, Figs. 338 and 339. Hence, as the eccentrics 11 rotate with the main shaft H, the rod 28, studs 29, and block B will rise and fall alternately for each revolution.

Two positions of the lever E are shown in Fig. 339; the oblique position marked E¹ represents the full-out position when all the locking knives D

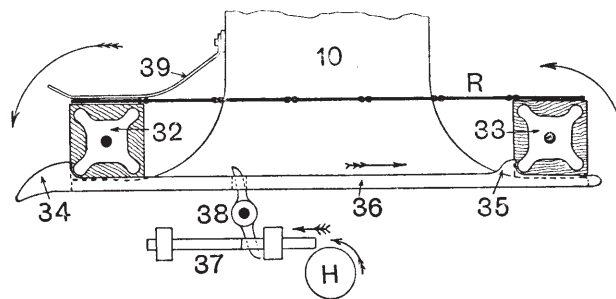

FIG. 341.

are clear of the punches J. The vertical position of the lever E represents the full-in position of the locking knives J. It has already been stated that the locking knives are pulled out positively by the action of the cam G, Fig. 333, on the short arm of lever E. This results in the compression of a spiral spring (not shown) on the rod 30, Fig. 339, and situated between the collar 31 and the block B. The energy thus stored in the spring enables the latter to draw in the locking knives D when the action of cam G, Fig. 333, is removed. At this time the griffe 22 will be up, and all parts ready for the block B descending to perform the cutting of the holes. As the block B descends, the fine spiral spring at O, Fig. 334, is compressed a little, and continues to be so until the block B reaches the lowest position, and the otherwise unaffected punches J have passed through the card R.

When the punches J have been withdrawn from the punched card, the latter is carried from between the cutting blocks, and another blank card of the chain placed in position by the partial rotation of the cylinders 32 and 33, Fig. 341. These cylinders are moved by means of the two

catches 34 and 35 on rod 36. The latter is moved positively by means of a cam on the shaft H which pushes the short rod 37 to the left, and the latter moves the lower arm of lever 38 in the same direction, so that the upper arm of the latter pushes the rod 36 to the right, and thus turns the two cylinders one-quarter round and in the direction indicated by the arrows. The rod 36 and other parts are returned to their present positions by means of a spiral spring.

The spring 39, attached to the frame 10, and a similar spring on the other side, serve to position the cards on the cylinders 32 and 33.

There are other repeaters on the market for the duplication of the ordinary and medium British pitch types of cards, but those illustrated and described probably represent the best known kinds. Whenever a certain pitch jacquard machine becomes permanently established in an industry, a corresponding repeater is almost sure to follow in due course, because of the saving which is effected by such machines.

Some duplicating or repeating machines are most suitable for repeating single cards of particular picks of simple weaves, or of all the picks in succession. Thus, in connection with the weaving of figured fabrics which require cross borders, there are usually large quantities of cards, cut for some simple weave, required to be used between each pair of cloths. In such cases, and also in the case of preparing stock cards of a similar nature, these machines are very useful. They are not intended or adapted to cut cards which have been previously laced.

The cards cut from such a machine can then be stored on suitable pegs so that one or more can be taken and used when desired for any particular purpose.

These particular kinds of repeating machines may also be used for the duplication of full sets of cards which have not been laced, but which have just come from a piano-card cutting machine, say from any of those illustrated in Chapter IV.

The American repeating machines appear very compact, as evidenced

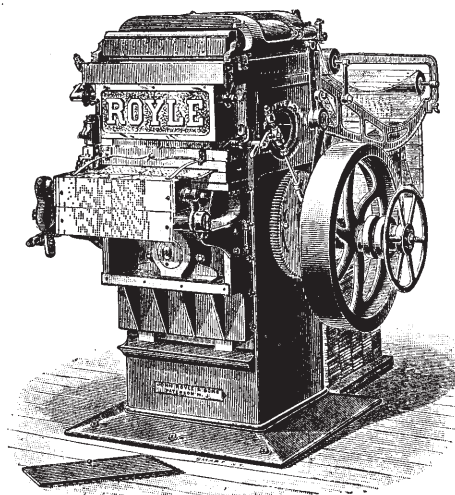

FIG. 342.

by Figs. 342 and 343 ; these illustrate respectively a French index repeater and a fine-scale repeater. It is impossible at present to show any of the actual cutting mechanism or the parts which operate it, but it might be stated that all parts, such as cords, chains, and springs, have been replaced by shafts, levers, gears, and similar appliances, so that the various movements may not, when set, be subject to variations which invariably accompany the use of the former group. Finally, the jacquard card cylinder is made of brass, and hence it is not affected by atmospheric changes.

It will be seen that in both the machines illustrated in Figs. 342 and 343 cards of the usual kind are used and laced, but it should be noted that the so-called fine-scale repeater is really what we have called a medium-

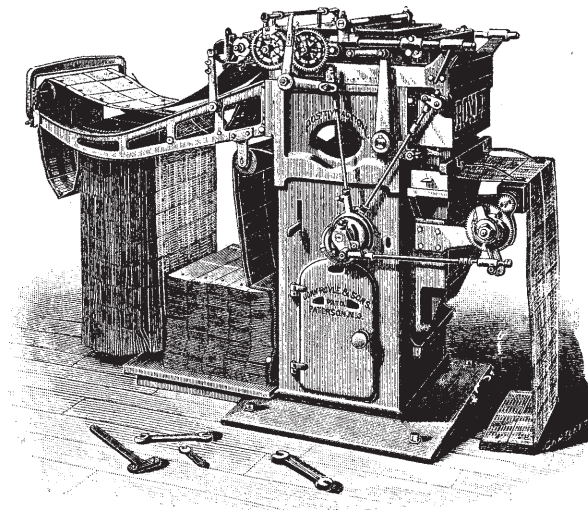

FIG. 343.

scale machine (see Fig. 332), as the actual pitch is identical with the McMurdo medium pitch repeater illustrated there.

The lacing for the cards may be accomplished on any suitable type of lacing or stitching machine.

We have already mentioned the fact that some repeating machines are constructed specially to duplicate unlaced cards which have

been damaged while in use, as well as for punching stocks of cards of the same simple weave throughout. Thus, in the manufacture of linen, cotton, and union damask tablecloths and serviettes or napkins, and, in general, in the weaving of all kinds of figured textures other than piece-goods—*e.g.* cloths, covers, and the like—it is almost invariably necessary or desirable to introduce a number of cards, punched for simple weave throughout, for the purpose of weaving the length required for the plain part of the cross borders as well as for that part which is to be utilised for hemming the ends of the cloths.

Such cards are seldom cut from the actual figured design ; in the first case, the actual number required is not always known when the design is being painted, and even if it were, it is not essential to have the correspond-

ing weft lines painted or the weave inserted. A much simpler plan is to have all such cards made independently of the design. They may be made on any of the repeating machines already illustrated; but they are often made individually by a pair of machines such as those illustrated in the foreground in Fig. 344, and when punched, it is a good plan to hang each set on a pin, as indicated in the upper part of the figure, so that one or more of each kind can be taken off quickly, either for replacing a similar broken one, or for forming the required number to add to those representing the actual figured portion of the design when the latter set is ready for lacing.

The view in Fig. 344 illustrates part of a card-cutting, repeating, and lacing room. The two machines involved are often termed respectively a "repeating machine" and a "railway press." The so-called repeating machine—which is, however, actually a punch selecting machine—is shown on the right, while the railway press, or actual punching machine, is shown on the left. There is another railway press in the background. It will be noticed that the arms of the large hand-wheel in the far machine are clearly seen, whereas those belonging to the hand-wheel of the nearer machine are invisible; the pulley, shaft, and wheel were running when the photograph was taken, and this accounts for the obliteration of the arms in the illustration. We shall have occasion to refer to this figure again when the line drawings of the two machines appear.

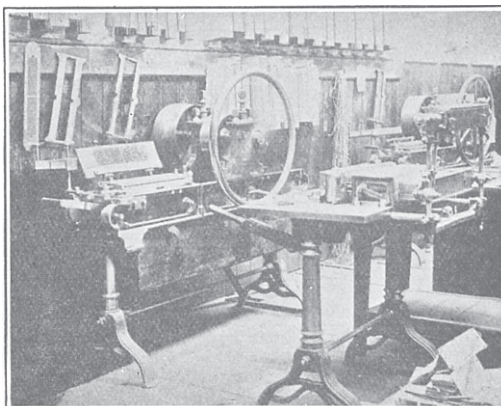

FIG. 344.

The first machine of the pair used for duplicating cards in the case of damages, or for a very slow method of repeating a set of cards, is illustrated in Fig. 345. We use the term "very slow" in reference only to the duplication of one set; if several sets of the same design were wanted, the machine would then be much more valuable, as will be explained later. As a matter of fact, the illustration Fig. 345 shows that the machine is arranged for the latter function, because there is a set of cards A on the cylinder B of the machine, and the cylinder is in the same plane as the needles. In this case it is seen that the machine is operated by means of a treadle C. After each downward movement of the treadle, the latter is returned

to its present position by the weight D. But since at its best such a machine, when working in conjunction with the "railway press," is but a poor substitute for the modern card repeater, we shall describe the two companion machines for the purposes already mentioned in connection with Fig. 344. We shall, however, letter the illustration in Fig. 345 in keeping with the line drawings of the same machine as at present adapted for the duplication of single cards.

An elevation of the same end of the machine as that shown in Fig. 345

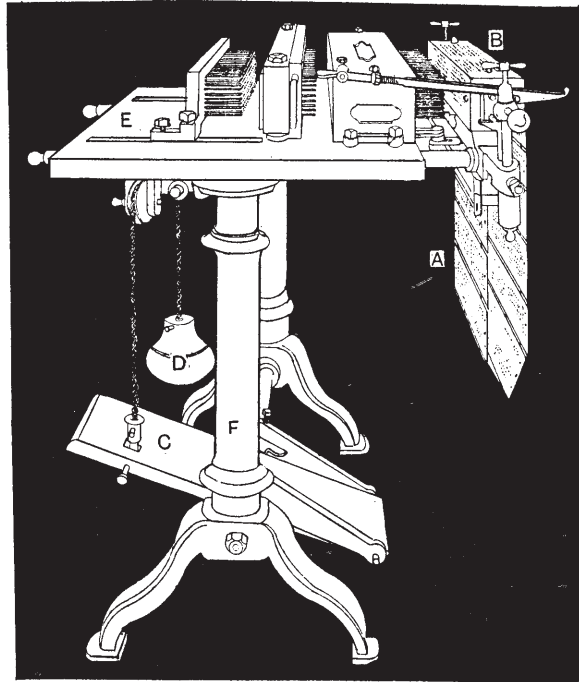

FIG. 345.

is reproduced in Fig. 346, but in this case the card cylinder B is shown in a much higher plane with respect to the other parts of the machine, and the cylinder B is without pegs—they are not required with this arrangement. A very similar disposition of the various parts is exemplified in Fig. 347, which represents a different type of machine made by another firm of machine makers, but adapted for the same kind of work; in this case, a treadle C is used, but it is returned by means of springs D, and the treadle and springs are connected by metal stirrups and flat leather bands which are supported by rollers, as shown.

The table E of the machine, Fig. 346, is firmly mounted on the end

frames F, and the table in turn supports all the parts which are essential for the selection of the proper punches. There are two sets of needles G and H, and one set of punches J, each set numbering 600. The needles G and H are much smaller than the punches J; the latter must, obviously, be the same size as those of the ordinary pitch piano

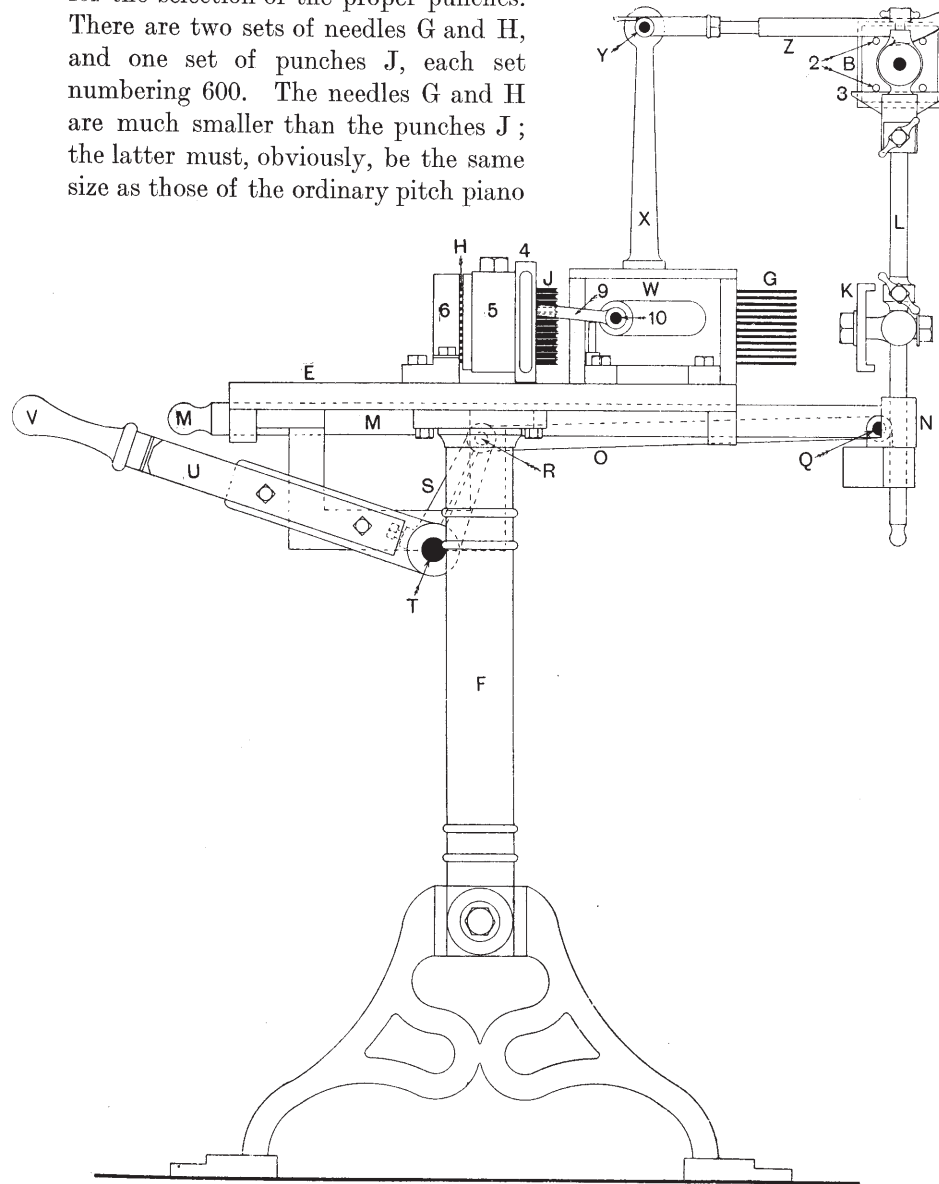

FIG. 346.

card-cutting machine, because they are to duplicate holes to correspond to those which have been cut originally on the ordinary pitch piano machine.

The parts are in their normal position in Fig. 346, and also in Fig. 348, which is a plan view of the table and its furnishings. The card to be duplicated, whether as a single card or as one of a set hanging over the cylinder B as illustrated in Fig. 347, is guided on to a pair of pegs on the card plate K, seen best in Fig. 346. This card plate K is secured to the two rods L which support the cylinder B, while the ends of the slide rods M, which are connected by the bar N, as shown in Fig. 348, encircle the upright rods L, as shown.

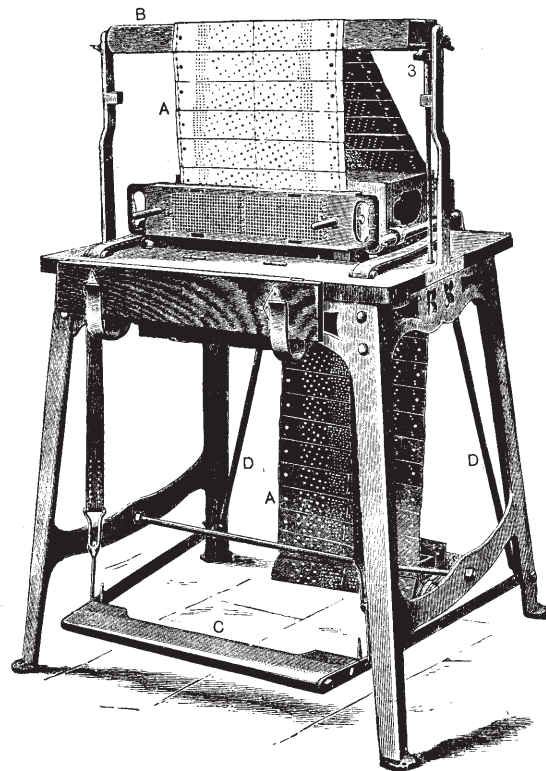

FIG. 347.

A rod O, Figs. 346 and 348, is attached to the bar N by means of a pin Q, while the other and forked end of the rod O is similarly attached by the pin R to the lever S fulcrumed on the shaft T, Fig. 346. Finally, a lever U, with handle V, is secured to the shaft T.

The needles G are those which are acted upon directly by the pilot card—*i.e.* the card which serves as the selecting medium for the duplication. These needles G are housed in the case W, and a pedestal X, secured to the upper surface of case W, supports an arm Y, upon which the turning catch Z is loosely fulcrumed.

The length of the catch Z can be varied slightly, so that its hooked end will operate satisfactorily on the pegs 2 of the cylinder B when the cards are arranged somewhat as demonstrated in Fig. 347. The pegs 2, when in their normal position, rest upon the head of the spring hammer 3, as indicated both in Figs. 346 and 347.

The punches J, or rather those which are not held for the time being by the punch-carrying block 4 when the latter has been removed from the machine—that is, from the position it occupies in the figure—are located in the stationary punch block 5; while the needles

H, with their carrier 6, are clear of the block 5, as will be indicated shortly.

The method of operating the repeater or punch-selecting machine is as follows: Suppose that the card shown in the upper part of Fig. 349, and numbered 567, to represent the corresponding pick of the design, had to be duplicated because of some damaged part. The two arrows 7 and 8 indicate the directions for reading the holes and blanks with respect to

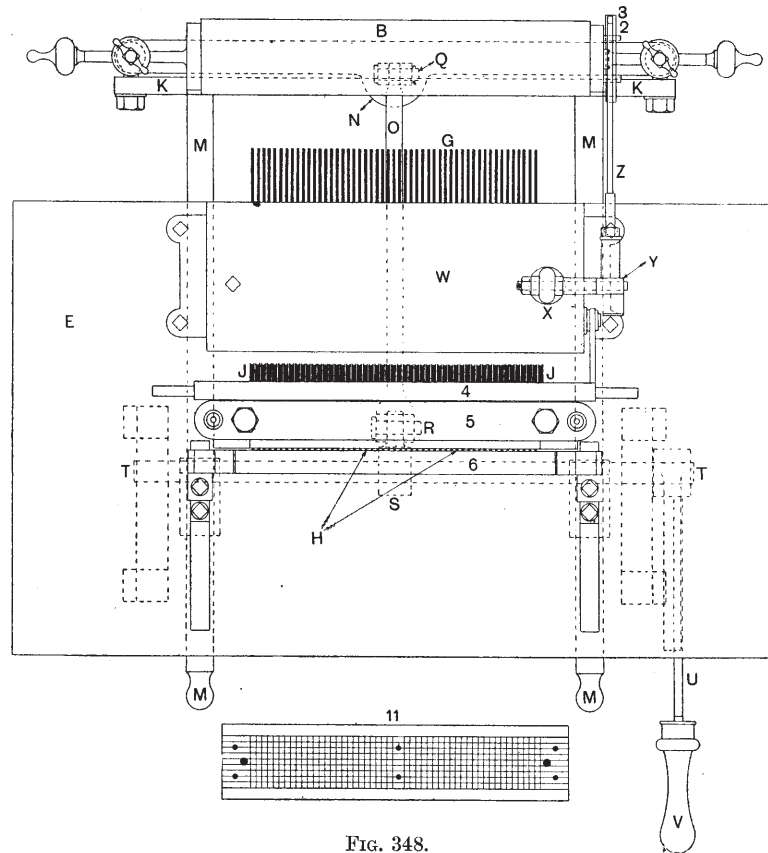

FIG. 348.

the needles 1 to 600 of the machine. The 26-row is on the left and the 25-row on the right when viewed as in Fig. 349. The punches for the peg and lace holes are not required in the case W, because these punches are always in position in the punch-carrying block 4, alongside the ordinary punches J.

The card, say, No. 567, as illustrated in Fig. 349, is placed on the pegs and against the face of the plate K, Fig. 346, so that its 12 long rows of

holes and blanks will face the corresponding 12 long rows of the selecting needles G. The handle V is then pressed down, an action which causes the lever S to move slightly counter-clockwise, and hence pulls the rod O, bar N, plate K, cylinder B, and all adjoining parts to the left, Fig. 346, until the plate K, or rather the card 567, Fig. 349, is in close proximity to the face of the case W.

Since the plate N, Fig. 346, is attached to the lever S, and since a further rod is attached to the short needle carrier 6, it follows that both move simultaneously and in the same direction, but the short needles H, in their carrier 6, are clear of the box 5 before the card on the plate K operates on the selecting needles G.

As soon as the card on plate K reaches the points of the selecting needles G, the blanks will force the corresponding needles against the same number of punches J, and will ultimately force these punches J into the box 5. Those selecting needles G which were opposite holes in the card would pass through these holes and through the corresponding holes in the plate K.

When the moving parts 6, N, etc., Fig. 346, have reached their full outward position to the left, the punches J and the needles G and H will have assumed the positions indicated in the plan view, Fig. 349. In this view all the selecting needles corresponding to the blanks in the top long row of card No. 567 are shown to have pushed their corresponding punches J into the box 5, whereas the remaining punches J, corresponding to the holes in the top row of the card, remain undisturbed, because their needles G have not been acted upon.

It will thus be seen that all those punches J which have not been pushed back, remain in the punch-carrying block 4, and when the needles G and H have been removed to the right, Fig. 346, until the needles G are clear of the punches J, and before the needles H have reached the remainder of the punches J in the box 5, the parts are in suitable positions for the removal of the punch-carrying block 4, with its complement of punches corresponding to the holes in the card No. 567, Fig. 349.

The small arm 9, fulcrumed at 10, Fig. 346, on a stud projecting from the side of the case W, holds the punch-carrying block 4 erect, but can be withdrawn so that the punch-carrying block 4 may be lifted out in order to be transferred to the next machine, the railway press, where the actual punching of the new card takes place. Only one row of needles G and punches J—the top one—has been introduced in Fig. 349, since more would simply have resulted in the illustration being made less effective. The foregoing description has reference to the duplication of 600's or 12-row jacquard cards. Provision must be made to duplicate 8-row and 10-row cards if necessary, and this provision takes the form of plates

drilled for the corresponding 8-row and 10-row machines. Thus the diagrammatic view 11 at the bottom of Fig. 348 illustrates a plate equal in size to a 600's or 12-row card, but 10 long rows only are shown; the places on the plate corresponding to the 1st and 12th rows of a 600's card are solid metal, and hence only 10 rows of selecting needles G, Fig. 346, would be in work, and the two outside long rows of needles would be

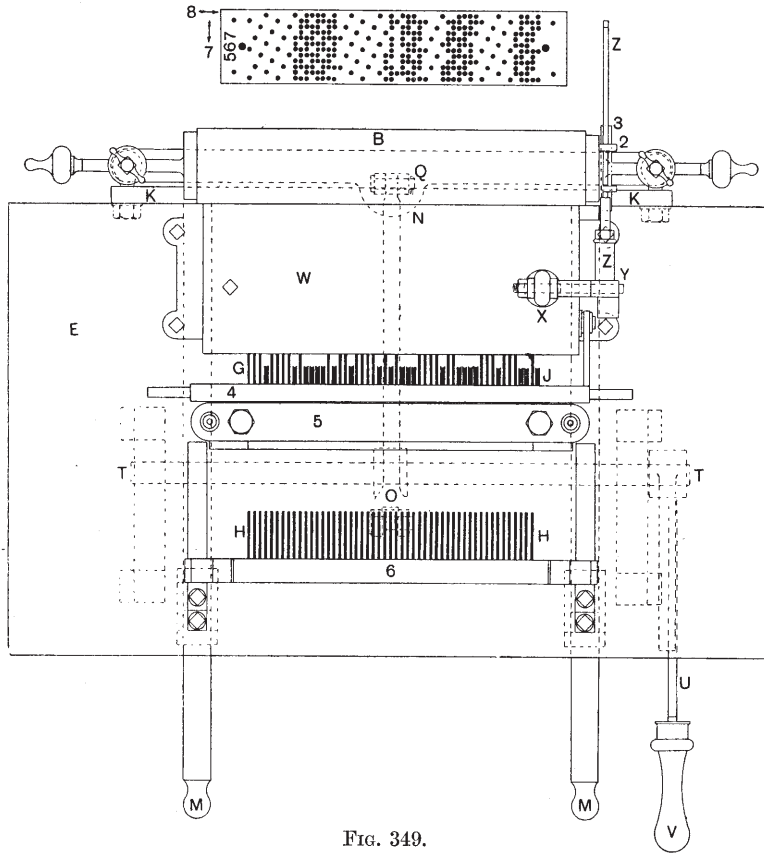

FIG. 349.

pushed to the left and their corresponding punches J pushed into the box 5 at each stroke of the plate. For 8-row or 400's cards the plate would have holes only in the eight middle rows, and it need hardly be said that the plate is placed in front of the plate K, Fig. 346, so that the rows of blanks would cover the holes in the corresponding rows in plate K.

The companion machine to that illustrated in Figs. 345 to 349, and the one which actually performs the punching of the cards, may be hand-driven or power-driven. One type of hand-driven machines is illustrated

in Fig. 350, the drum or roller A being operated by means of the projecting handles on the hand-wheel C. The punch-carrying plate 4 is shown on the top of the framework, and this plate has to be pushed under the roller A, the point where the card is cut. The small discs of cardboard, punched from the card, drop into the box near the floor.

A power-driven machine is illustrated in Fig. 351, in which case the roller A, on the shaft B, is placed in and out of action by the fast and loose pulleys D and E, while the hand-wheel C, on the same shaft B, is without the projecting handles shown in the machine in Fig. 350. The whole is supported by the substantial framework F.

The so-called "railway press" shown

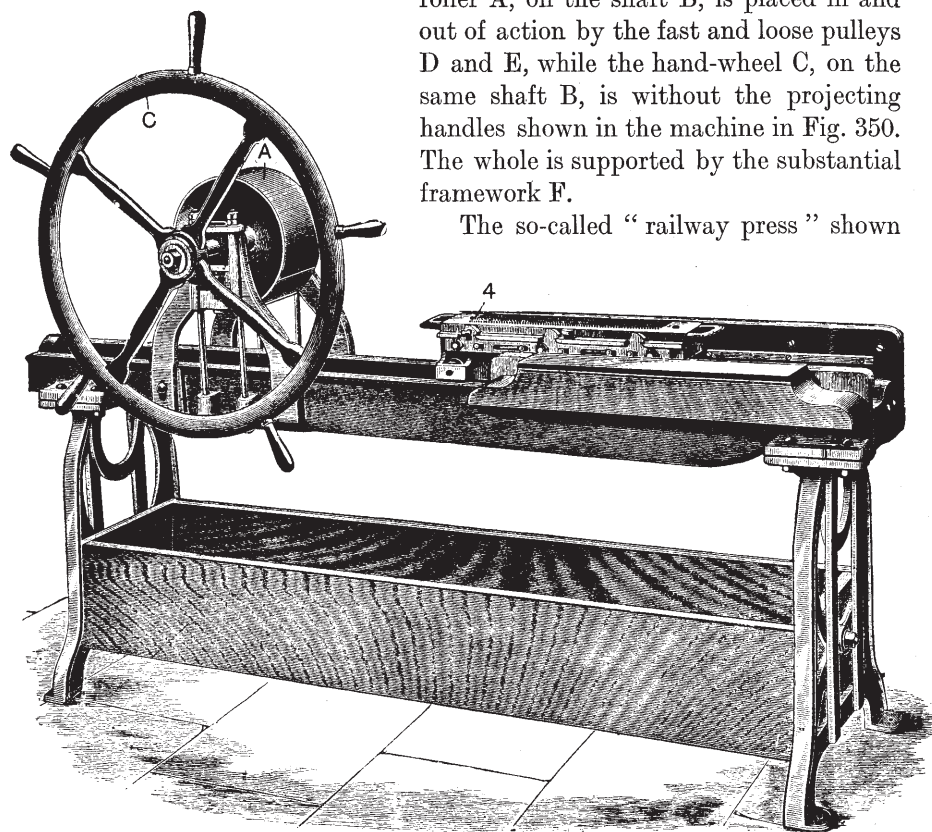

FIG. 350.

in Fig. 351 is of the same type as those shown near the wall in Fig. 344. It will be observed that in these two machines in Fig. 344, one pulley only is used, the main shaft being kept running while the engine or main shaft is in motion; in this respect the machines differ from that illustrated in Fig. 351.

Figs. 352 to 356 are line drawings of the machine exhibited in Fig. 351. Fig. 352 is a front elevation, Fig. 353 is an end elevation of the feed

side, Fig. 354 is a plan, while Figs. 355 and 356 are enlarged views of the punch-carrying plate 4.

After the selection of punches has been made by the machine illustrated in Figs. 345 to 349, and as already described, the punch-carrying plate 4 is removed from the pins or pegs, Figs. 346, 348, and 349, and the plate with its complement of punches taken to the railway press illustrated in Fig. 350, or to the one shown in Figs. 351 to 356. The plate 4 is placed in the position indicated in Figs. 355 and 356.

We shall assume at present that the blank card which has to be punched is under the punch-carrying plate 4 and between it and a correspondingly drilled plate, near the base of the plate-carrier G; the method of placing the card in this position will be described after the actual operation of punching has been explained.

The plate-carriage G is, naturally, in its position on the rails H, Fig. 354, although shown detached in Figs. 355 and 356. In Fig. 354 only a small portion of the plate-carrier G is shown, but its handle J indicates its relation to the whole carriage shown in Figs. 355 and 356.

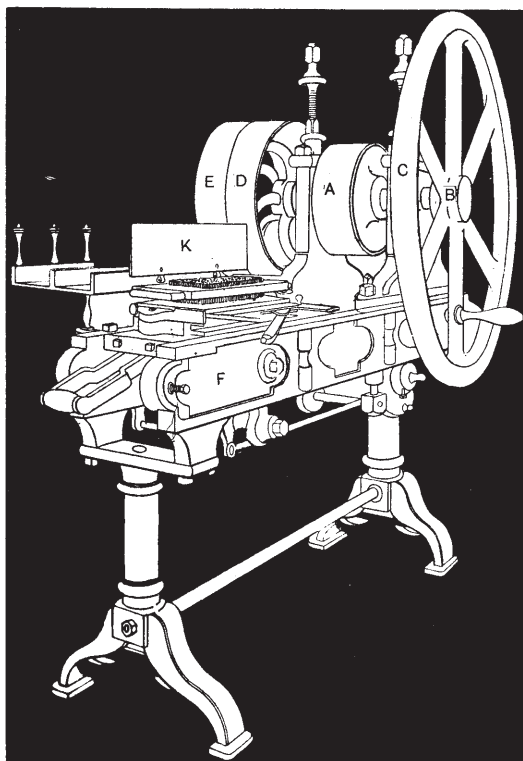

FIG. 351.

The two rails H, Fig. 354, extend, as shown, to the far end of the machine, and it is necessary, when the card is in position under the plate 4 and its punches, to cover the latter with the leather shield K, Fig. 353 (shown also clearly in Fig. 351). Then the plate-carrier G, with its charge, is pushed under the rotating roller A, with the leather shield K in direct contact with the roller. This results in the punches being forced downwards, and their ends pushed through the card and into the correspondingly drilled plate in the base of the carriage G. The full cutting of the card is thus

accomplished, but it is necessary to withdraw the plate-carriage G in order that the punched card may be removed, and another blank card placed in

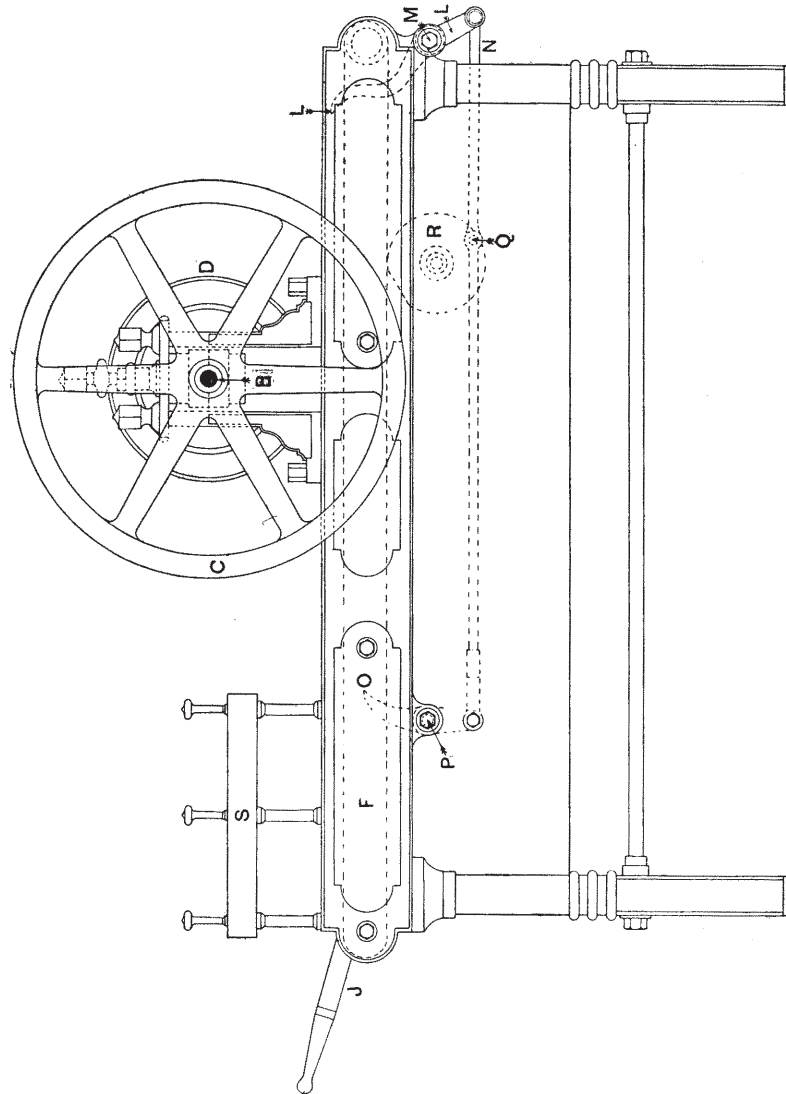

FIG. 352.

the same position for the duplication of another card by the same punches, or by another arrangement of punches selected by a different card in the machine illustrated in Figs. 345 to 349.

Near the right-hand side of the machine is a lever L, Fig. 352, fulcrumed

at M. The upper and longer arm of the lever L is free, whereas the lower and shorter arm of the same lever is attached to the end of the rod N. The rod N extends to a point near the front of the machine, where it is attached to the lower arm of lever O, fulcrumed at P. A pin Q, projecting from the rod N, is in contact with the flat-sided, nearly circular part R; it has a flat part at one point of its periphery, and this disc R is in touch with the rails H.

When the plate-carrier G is on the left, the circular part of the disc R is supporting the rail H; but when the carrier G has passed beyond the roller A, Fig. 352 (that is, when the card has been punched), the end of the carrier G comes in contact with the end of the upper arm of lever L. The end of the lever L is forced to the right, and this causes the lower and shorter arm to move to the left, and hence the pin Q, through the movement of the rod N, rotates slightly the almost perfect disc R and until the flat part is horizontal.

The operation of placing the flat part of the disc R horizontal allows the rails H to descend slightly, and this enables the operative to withdraw the plate-carriage G freely and without the leather shield K coming into contact with the rotating roller A. When the carriage G is nearing the left-hand side, the opposite end of the carriage comes in contact with the free end of the lever O, and hence the lower end of this lever causes the rod N to move to the right and to place the disc R in the position shown in Fig. 352 ready for the next forward movement of the plate-carriage G.

As the punched cards are removed from the carriage they are placed in the receptacle S; one compartment may be utilised for the punched cards, as stated, and the other compartment for a stock of blank cards.

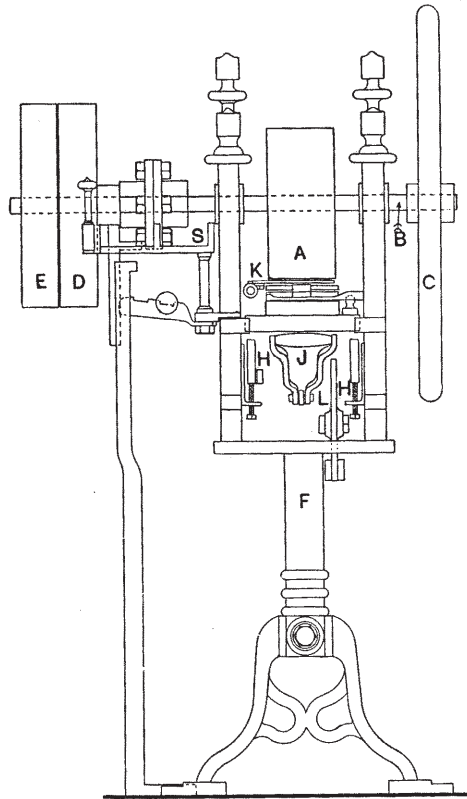

FIG. 353.

It is obvious that the punched card must be removed from the plate-carriage G before another blank card can be introduced ; the card is removed in the following manner : The handle J, Figs. 355 and 356, is

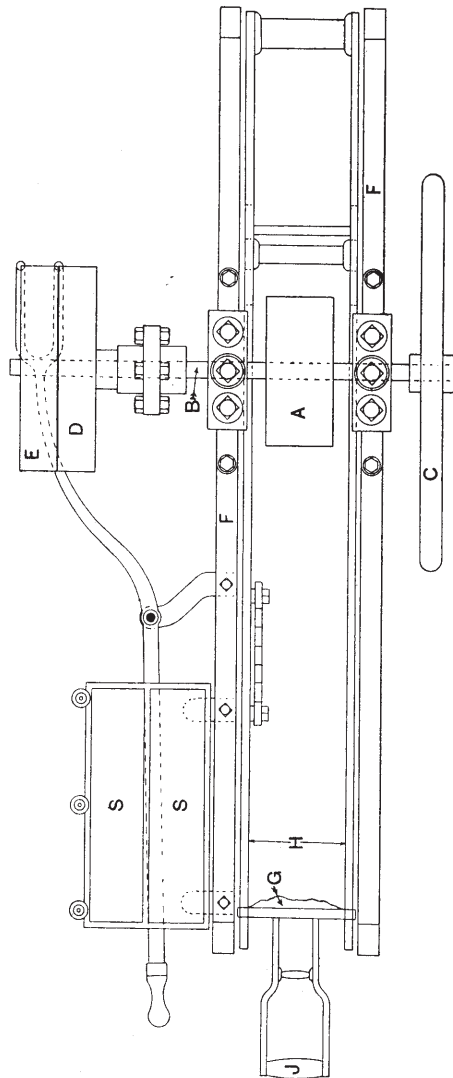

FIG. 354.

pressed downwards to lift the plate 4 until the ends of the punches are withdrawn from the lower plate and clear of the punched card. Then a catch is moved to release the handle or lever T, and a pin projecting from the upper surface of the lever T, and about midway between its ends, enters a slot in the card-slide U, and so enables the card-slide, with the punched card thereon, to be withdrawn when the handle T is moved slightly counter-clockwise about its fulcrum. The punched card is then removed from the card-slide U, another blank card inserted in its place, and the handle T returned to its present position to carry the newly inserted blank card immediately under the punches in the punch-carrying plate 4.

It will be understood that 8-row, 10-row, and 12-row jacquard cards will require different kinds of card-slides U. Each card-slide is made so that it will fit the plate-

carrier G, and place the card centrally with regard to the peg-holes of the plate.

Two special card-slides are shown distinctly in Fig. 344, hanging against the wall. This illustration also shows clearly the leather shield K which,

as already stated, is turned down to cover the punches in the plate 4 just before the plate-carrier G is pushed under the rotating roller A.

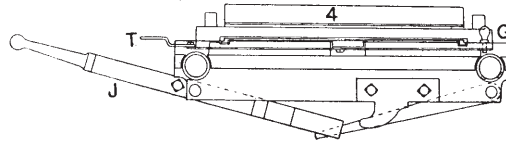

FIG. 355.

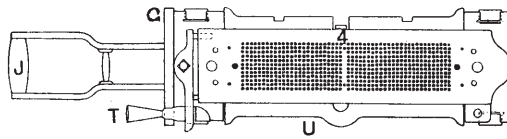

FIG. 356.

This leather shield is open in Fig. 344, and is seen immediately under the above-mentioned two card-slides U ; it is also open in Fig. 351.

CHAPTER XVIII

FINE-PITCH REPEATING MACHINES

THE piano machine used for punching the holes in endless paper cards for the fine-pitch Verdol machine is illustrated and described in Chapter VIII. We propose now to discuss the machine by means of which the pilot set of cards punched on the above piano machine is utilised for duplication purposes in the fine-pitch repeating machine.

A photographic reproduction of a fine-pitch repeater for endless paper cards is illustrated in Fig. 357, this particular view being taken from the back of the machine. This general view of the back, and the side opposite to the drive, illustrates quite well what might be termed the back harness with its heck, lingoos, and other parts, as well as the sliding part of the punch box. It also shows a great part of the arrangement provided for enabling the attendant to mount to the top of the main frame in order to place the pilot cards in position.

The front harness is shown distinctly in Fig. 358, which illustrates the front of the machine, the front of the punch box, card reels or cages, and the driving arrangement. It will be observed that the front harness in this figure, as well as the back harness in Fig. 357, occupies only two-thirds of the full capacity of the machine; this is because, in the particular machine photographed, 880 needles and hooks were in use out of a total of 1320. The width is divided into three sections, as shown by the divisions in the punch box in Fig. 358, each section of which contains 440 needles and hooks.

The above two views will be referred to again later; meanwhile we need only notice that in Fig. 358 there is a long vertical rod between the driving belt and the end of the main frame, and practically parallel to both, which, with other parts, provides means for conveying through the rotary movement of the main shaft and the up-and-down movement of a cam bowl, the usual movements of the lifting griffe of the jacquard at the top of the structure.

The continuation of this lifting rod, or rather the lever to which it is

attached, is shown in the bottom right-hand corner of Fig. 359. The last-mentioned lever is fulcrumed as shown on the heavy horizontal rod or shaft in the front of the jacquard. Two other levers, one at each side of the jacquard, are fulcrumed on the same rod or shaft, and these serve to complete the connection to the two vertical rods which operate the griffe of the jacquard.

As indicated, the illustration in Fig. 359 shows the driving side of the jacquard; the other side, which is slightly different, appears in Fig. 363.

The side shown in Fig. 359 illustrates the mechanism which causes the card cylinder to rotate intermittently, and which keeps it free from vibration after each movement is completed—that is, when the part of the endless paper corresponding to a card has been placed in position under the short vertical selector needles of the Verdol jacquard.

It is not intended to describe the jacquard fully at this stage, but we might mention the fact that the short vertical selector needles are housed in the box in the upper part of the jacquard and immediately above the cylinder. The circular end of the cylinder is clearly seen with the roller of the spring-actuated lever (hammer) in contact to keep the cylinder motionless while the selection is being made. A hole in the paper card below a selector

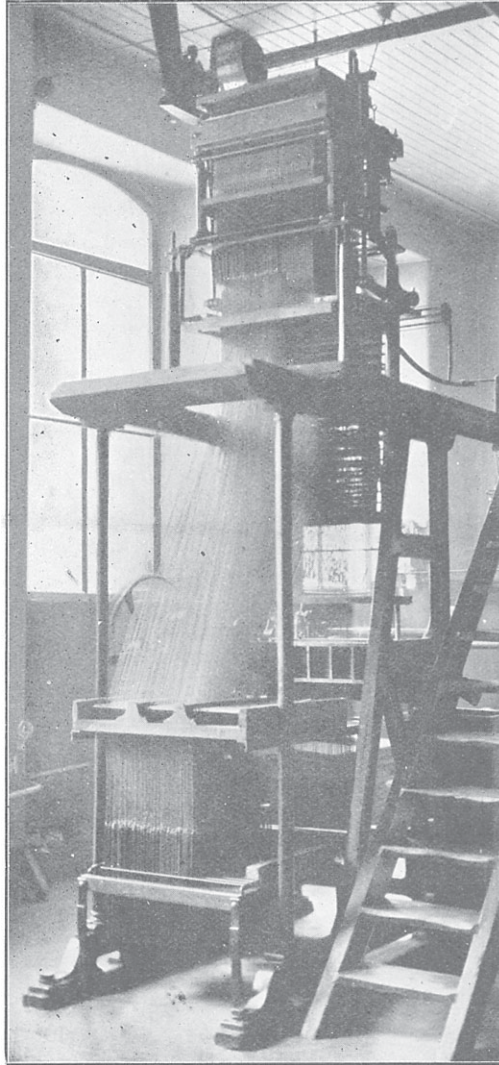

FIG. 357.

needle enables the end of the latter to enter, while, on the other hand, a blank keeps the corresponding selector needle in the high position. These selector needles simply place each row of horizontal needles in

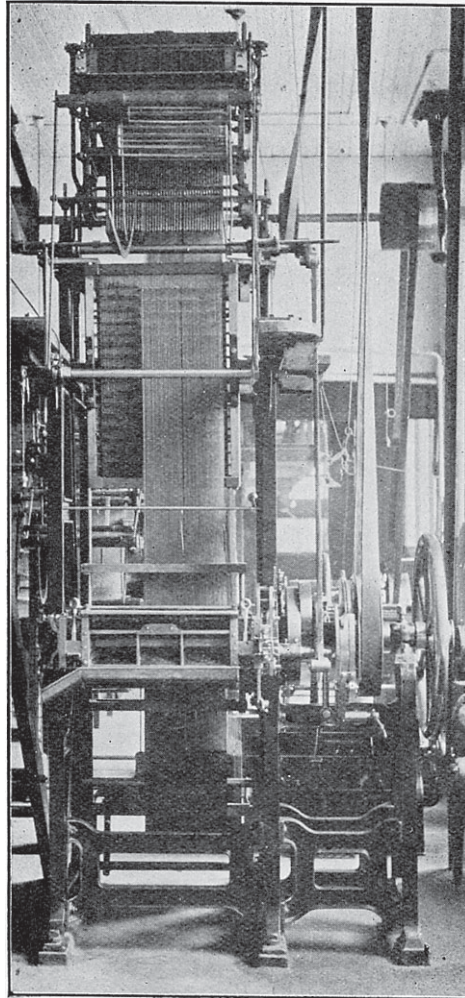

FIG. 358.

two distinct horizontal planes, so that some of the latter may be pressed back and others missed in order to place the hooks or uprights of the jacquard in the desired positions. The particular way in which the two sets of cards in Figs. 357 and 358 are actuated will be fully explained later.

It will be understood that the endless paper cards, or rather the wide strip of paper with strengthening strips for the peg-holes, which has been prepared in the fine-pitch card-cutting machines, is passed over the cylinder of the jacquard, while the blank endless strip to be punched or repeated for the same pattern is passed over a corresponding cylinder in the punch box in Fig. 358. On neither cylinder is the paper in position, because it would have covered part of the machine. In Fig. 359, however, the paper strip is shown over one of the guides and between the two bars of the card or paper cradle.

The front of the fine-pitch repeater, corresponding to Fig. 358, is illustrated in the line drawing in Fig. 361, while the method of driving the griffe of the jacquard is shown in Fig. 360. The framework of the machine is in two parts, the high or main frame A, Fig. 361, and the supplementary or low outside frame B; these two parts are kept in their vertical positions by the compound rails C and D. The actual driving parts of the machine

are supported in suitable bearings, and, as shown, between the two frames, while the drive is obtained by a type of friction clutch. On the end of the main shaft E, and outside the supplementary frame B, is the balance

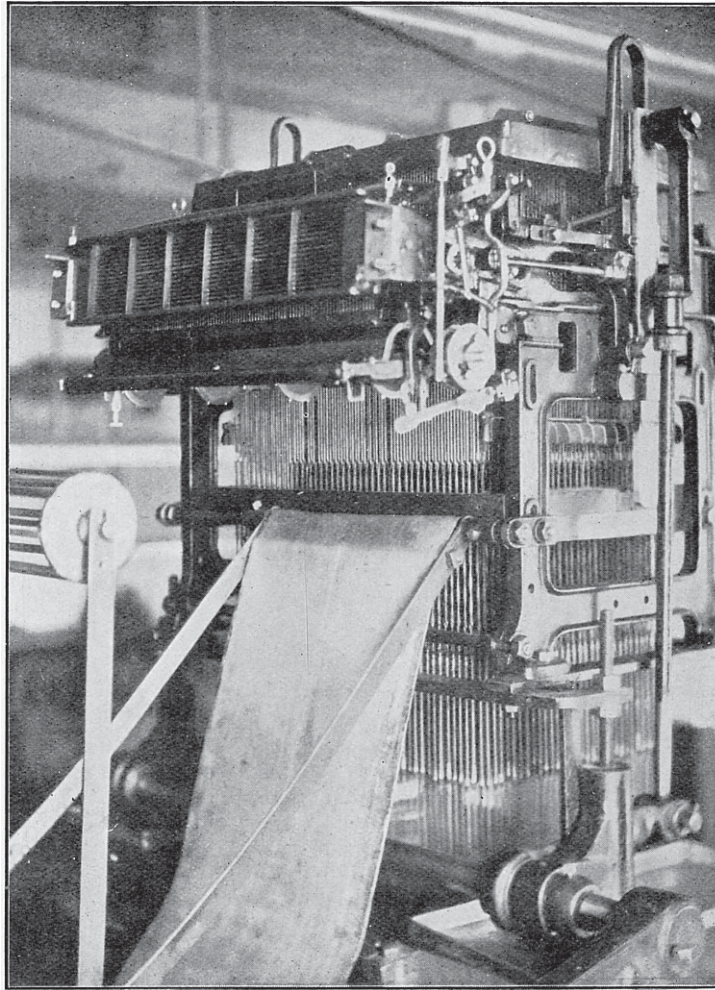

FIG. 359.

and hand-wheel F, while a belt coming from the line-shaft shown in Figs. 357 and 358 communicates the power to the flanged pulley G, Fig. 361. The horizontal arm H, seen best in the end elevation in Fig. 362, and the vertical arm J, Fig. 361, are compounded and fulcrumed at K, and the machine is inoperative when these parts are in the above-mentioned

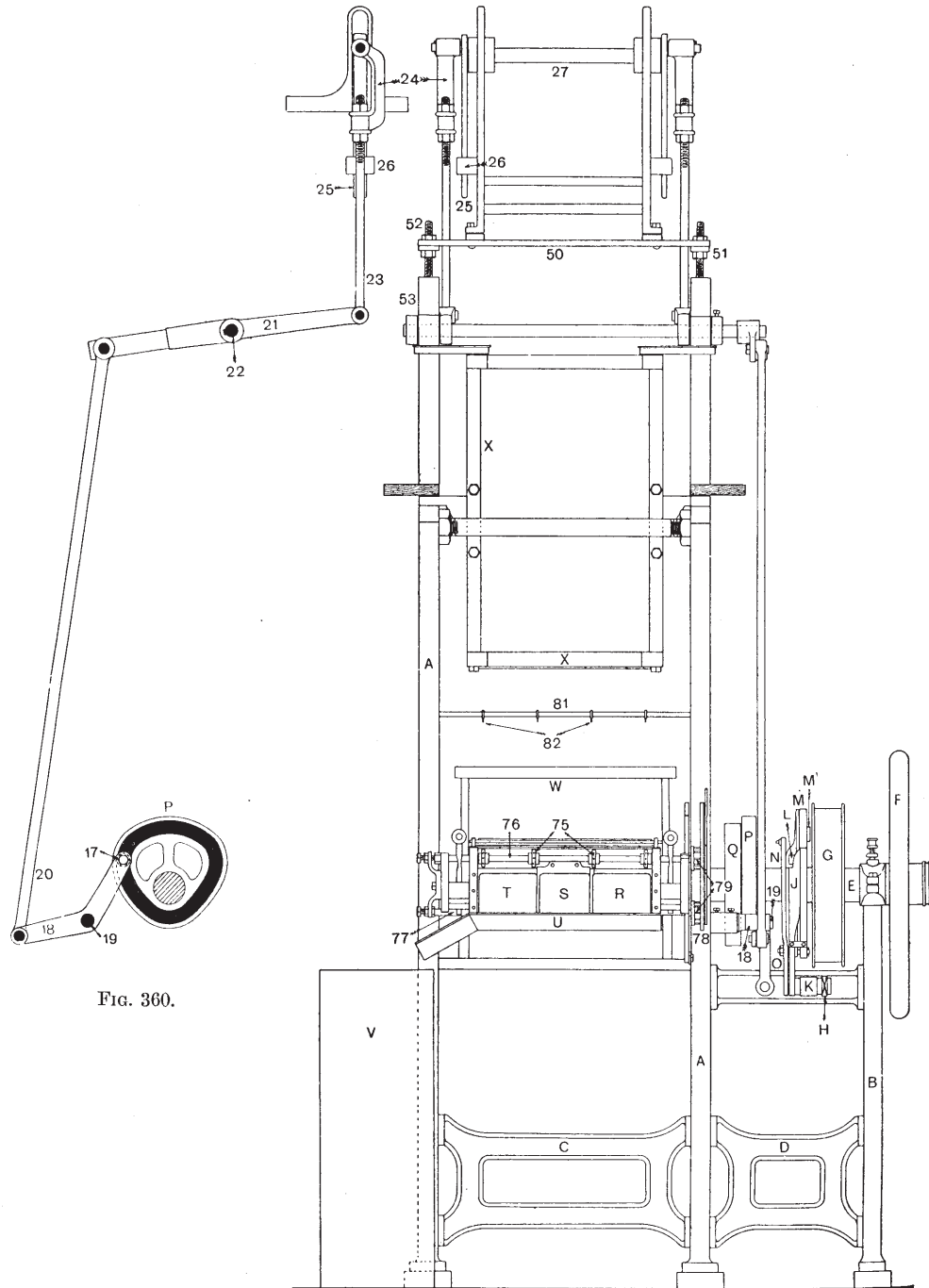

FIG. 360.

FIG. 361.

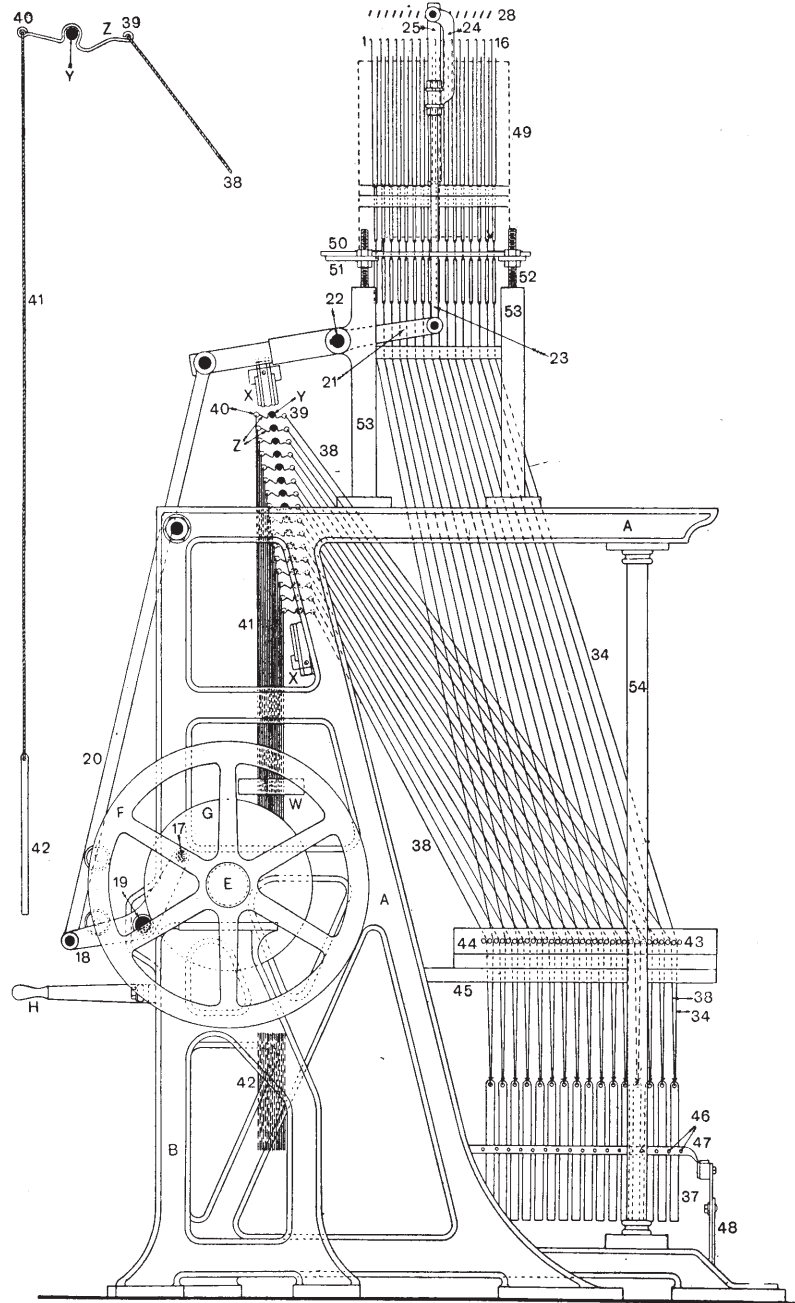

FIG. 362.

positions. When, however, the end of the handle H, Fig. 362, is pressed downwards, the upper end of the arm J, Fig. 361, moves slightly towards the operator or reader, and is thus withdrawn from contact with a projecting piece L cast on, or preferably fixed to, the side of the clutch plate M. On the other face of the clutch plate M is a projecting piece M¹ adapted to be withdrawn from, or to enter in, a recess in the inner face of the flanged pulley G. This arrangement enables the upper part of the powerful flat spring N, fixed at O, to slide the clutch plate M on the shaft, and to press the part M¹ sufficiently far into the recess in the inner face of the flanged pulley G to enable the latter to drive the clutch plate M and the shaft E. Conversely, when the handle H is raised to the present position, Fig. 362, the curved part of the upper end of arm J, Fig. 361, is placed in the path of the projecting piece L of the rotating friction plate M, and the piece L is thus caused to slide down the curved part of the arm J and to withdraw the clutch plate M and the part M¹ from contact with the inner face of the driving pulley G. Provision is made to stop the belt from rotating if for any reason such a condition is desired.

On the same shaft E, Fig. 361, are two cams P and Q; the cam P with its connections drives the jacquard at the top of the frame, while the cam Q communicates motion to the sliding part of the punch box. The front part of the punch box is situated immediately behind the three openings R, S, and T, while the gutter U serves to catch and guide the cuttings or small discs punched from the paper strip into the large box V. The front comberboard is shown at W, while the framework X supports all the rods Y, Fig. 362, and the latter serve as fulcra for all the wire levers Z. An enlarged view of one wire Z and its fulcrum rod Y is shown in the detached view on the left of Fig. 362. All these parts shall receive consideration shortly.

In the grooved path of the cam P, Fig. 360, shown 90° farther round, with respect to Fig. 361, is an anti-friction roller 17 running loosely on a stud near the upper end of the bent lever 18 fulcrumed at 19; see also Fig. 362. The long connecting-rod 20 is attached to the outer end of lever 18 and to the long and outer arm of lever 21 fulcrumed on the shaft 22. This is the shaft shown clearly in the foreground in Fig. 359. The shorter and inner arm of lever 21, Figs. 360 and 362, is attached to the vertical rod 23, and the latter is adjustably attached to the lower end of the bent part 24. The upper end of the bent part is attached to a pin projecting from the side of the slide 25, which is guided in its up-and-down movements by the bracket 26, Figs. 360 and 361; see also Fig. 359. It will be understood that the inner part of 21 and parts 23 to 26 inclusive are duplicated at the other side of the jacquard, and that the two sliding bars 25 are attached directly to the griffe frame 27, within which are the sixteen knives 28, Fig. 362.

The above-mentioned duplicated parts are illustrated in Fig. 363, which is an enlarged view of the jacquard at the opposite side to the driving. The hooks or uprights shown are really those belonging to the last row of the machine, but they correspond to the positions of Nos. 1 to 16 at the other side of the machine, and have been marked as such. These hooks are operated in the usual way by horizontal needles, and need not be discussed here. They are placed in position, however, by a series of short vertical selector needles housed in the box 29.

An enlarged view of one of the hooks, say No. 1, appears in Fig. 364. A lath 30 passes between the two wires of each hook in a long row, and thus serves to keep the upper bends of all the hooks in that particular row facing the knives 28 and the cylinder. A twisted cord 31 is attached to the bottom bend of the hook or upright, and then a cord 32 (often a wire) joins the cord 31 to the weighted piece 33. Lastly, the cord 34 attached to the bottom of the weighted piece 33 is the usual harness cord, which stretches in this case direct to the lingoe 37, Fig. 362.

Each lingoe 37, Fig. 362, is connected to two cords: one cord, 34, passes, as stated, direct to the bottom bend of the hook in the jacquard; while the other cord, 38, is connected to the bend 39 of the wire Z fulcrumed at Y. (See the large detached view on the left of Fig. 362.) To the other end 40 of the wire Z is attached a cord 41, and this cord is under the influence of one of the front lingoos 42. There are intermediate parts between the end 40 of the wire Z and the lingoe 42, but these will be discussed in connection with further illustrations. In the meantime, it will be seen that all the back harness cords 34 pass between alternate pairs of glass rods 43, while the cords 38 from the end 39 of wire Z pass between the other alternate glass rods 43. All these glass rods are housed in the upper back heck 44, and the latter is supported by the brackets 45. The lingoos 37 pass between the iron rods 46 of the bottom back heck 47, which is held in position by the brackets 48.

From the parts illustrated in Fig. 362 it will be observed that when any hook 1 to 16, in the row illustrated, or in any other row in the jacquard, is lifted by the knife 28 to the high position indicated by the upper knife 28 in Fig. 364, the corresponding harness cord 34 and lingoe 37, Fig. 362, will be raised. Simultaneously, the cord 38 exhibits a tendency to become slack, and this slack is immediately taken up by the gravitational action of the front lingoe 42. This obviously causes the wire Z to rotate slightly counter-clockwise as the cord 41 and the lingoe 42 descend.

The jacquard itself, which is of the Verdol type, is represented in Fig. 362 by the dotted rectangle 49, and is supported as shown by two pairs of plates 50 and 51, at right angles to each other, and adjustably mounted for height on the screws 52 rising from four substantial brackets 53. Two

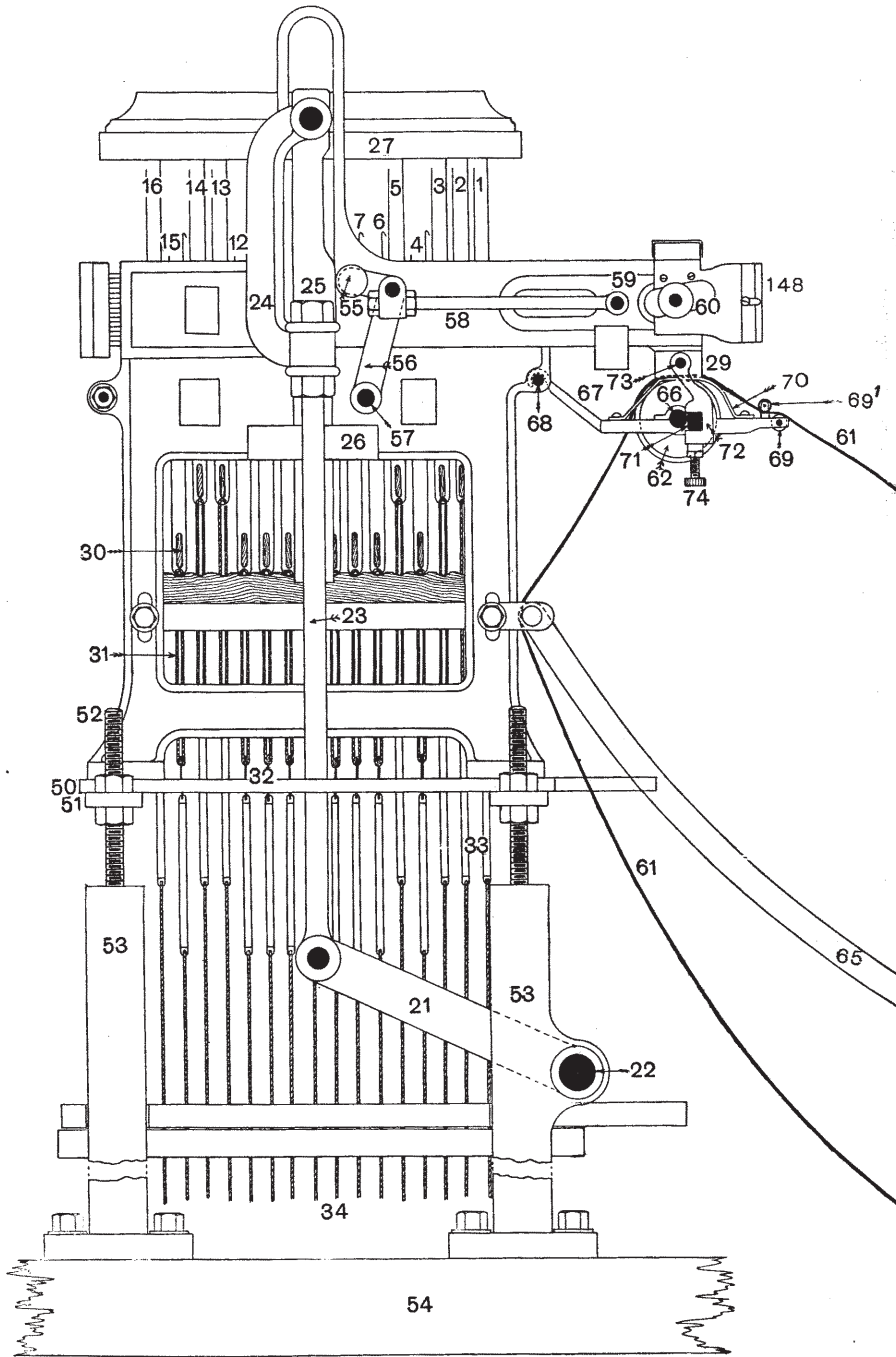

FIG. 363.

of the brackets 53 are provided with bearings for the heavy shaft 22. The whole is supported by the long back rails of the frame A and by the columns 54. Most of these parts appear on a larger scale in Fig. 363, and this view also shows that when the griffe 27 is raised the bulged portion of the slide 25 forces out the anti-friction bowl 55 of the lever 56 fulcrumed at 57. This action causes the rod 58 to push outwards the slide 59, which, in virtue of the oblique slot 60, causes the short vertical indicator needles in box 29 to be raised slightly in order, as well as in time, to allow clearance between the bottom ends of the vertical needles and the card or paper 61, when the latter is carried partially round by the movement of the cylinder 62.

The strip of paper 61, which has been punched in the fine-pitch piano machine according to the required design, and which therefore acts as the pilot set on the repeater, passes, as shown,

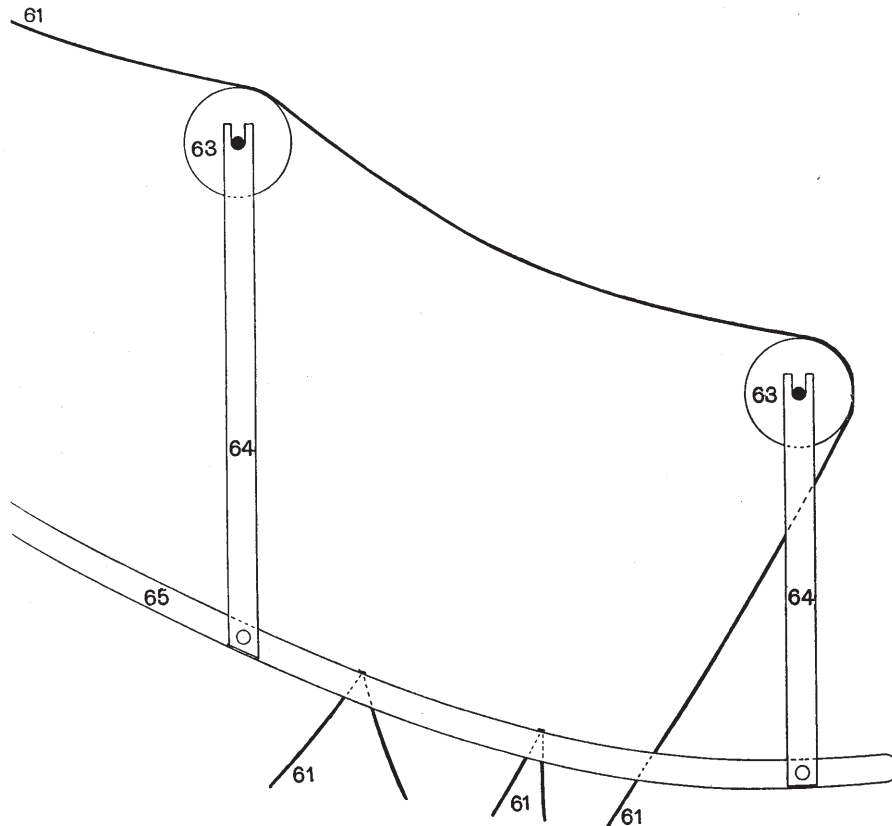

FIG. 363.

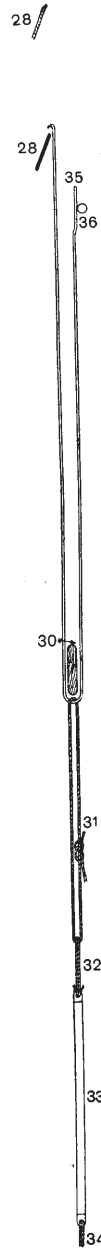

FIG. 364.

over the guide pulleys 63 supported in the slots in the upper ends of brackets 64. The lower ends of these brackets 64 are secured to the cradle 65.

In the general and enlarged view in Fig. 363 the cylinder 62 is in position with the vertical needles clear of the paper 61, but ready to pass through the holes or to be held up by the blanks or uncut portions immediately the griffe 27 descends.

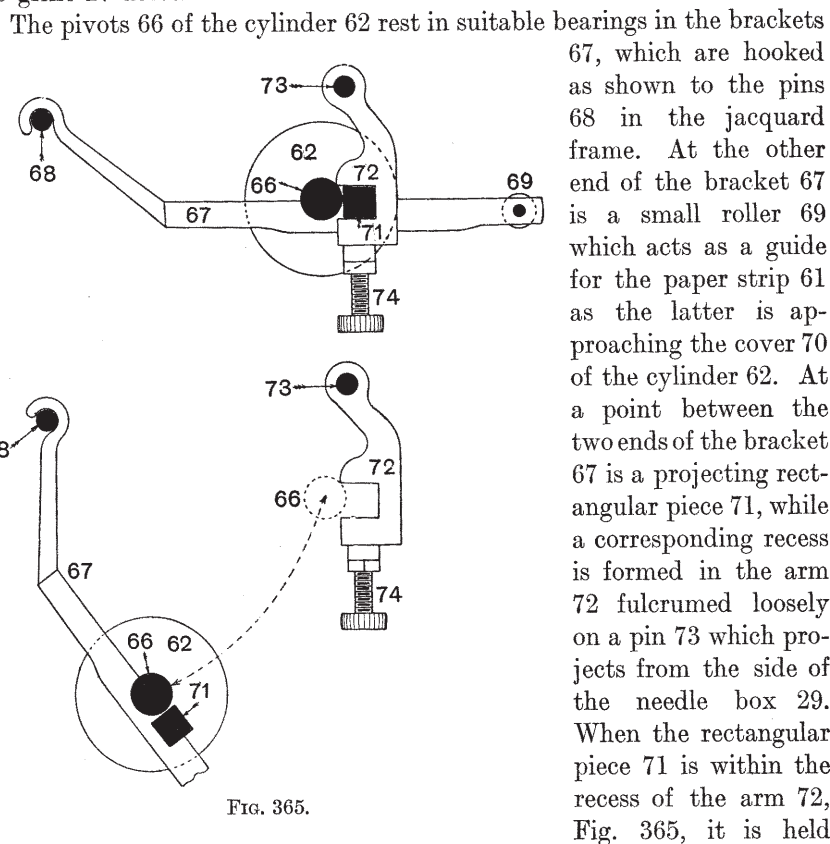

FIG. 365.

The pivots 66 of the cylinder 62 rest in suitable bearings in the brackets 67, which are hooked as shown to the pins 68 in the jacquard frame. At the other end of the bracket 67 is a small roller 69 which acts as a guide for the paper strip 61 as the latter is approaching the cover 70 of the cylinder 62. At a point between the two ends of the bracket 67 is a projecting rectangular piece 71, while a corresponding recess is formed in the arm 72 fulcrumed loosely on a pin 73 which projects from the side of the needle box 29. When the rectangular piece 71 is within the recess of the arm 72, Fig. 365, it is held securely in that position by tightening the screw 74. After the repeating has been completed and it is desired to remove the pilot strip of paper 61 from the cylinder 62, the screw 74 is slackened and the arm 72 pulled to the right to sever the connection between the rectangular part 71 and the recess in the arm 72. When this is done, the bracket 67, with all its parts, may be placed in the position indicated in the lower part of Fig. 365, in virtue of the bracket 67 being free to rotate partially on the pin 68.

The paper strip to be cut, or repeated, as it is termed, is drawn forward

by the pins or pegs in the discs 75, Fig. 361. These discs 75 are spaced on the shaft 76, the shaft itself, as well as its companion 77, being rotated intermittently by the action of the sliding catches 78 on the wires of the squirrel cages 79.

The wires of the squirrel cages 79 are fixed in the discs 80 (see Fig. 367), and these, together with the driving discs 75 and the shafts 76 and 77, constitute the two cylinders which move, forwards or backwards, the strip of paper to be duplicated.

The shaft 81, Fig. 361, carries four short-hooked levers 82. To one end of each lever is a spiral spring (not shown), and cords pass from these

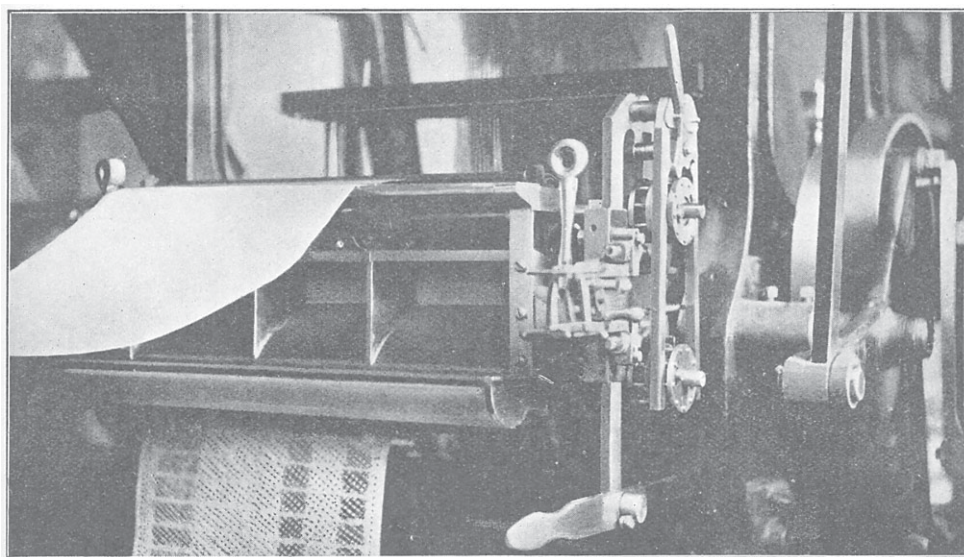

FIG. 366.

levers to place the punches for the peg-holes in or out of action. A lever fixed on the end of the shaft or rod 81 can be turned through approximately 90 degrees to rotate the rod into either the on or the off position.

The reproduction in Fig. 366 is a specially prepared photographic view, on a large scale, of the mechanism which operates the paper to be cut or repeated. The pilot set of cards—or, rather, the length of paper—cut on the fine-pitch piano machine, passes to the jacquard of the fine-pitch repeater, as indicated by the numbers 61 in Fig. 363. This fine-pitch jacquard of the repeater, as already pointed out, lifts the cords 34, Fig. 362, as well as the cords 38; this dual operation results in the lingoës 42 descending and placing in position the cords so that the repeating or copying

of the design on the pilot cards, or paper 61, Fig. 363, may be transferred, or, rather, repeated, on a new set of cards or paper. The exact way in which this latter operation is performed has not yet been explained, but the actual cutting or punching is performed immediately behind the mechanism illustrated in Fig. 366, or, rather, in the space behind and

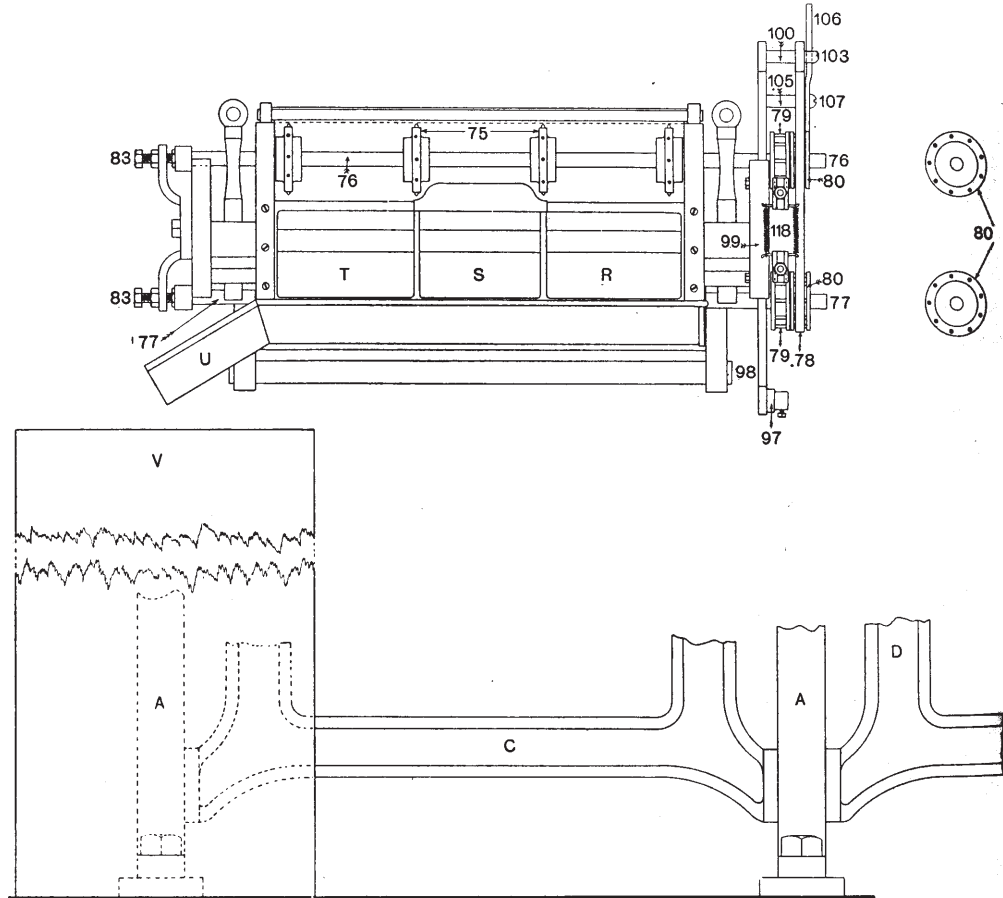

FIG. 367.

between the two rods 76 and 77, Fig. 367, and while the paper is in the vertical position.

It will be seen on referring to Fig. 366 that the horizontal or upper part of the paper is uncut, whereas that part which is descending from the lower part of the mechanism is perforated, and will be in the same order as the cutting on the paper which happens to be in work on the cylinder of the jacquard.

As previously mentioned, the small paper discs which are punched out of the paper sheet slide down the inclined planes R, S, and T, Fig. 367, and into the horizontal gutter or spout. (See Fig. 366 also for these parts.) The discs are periodically drawn forward by hand, and ultimately pass down the inclined gutter U into the box V. The box V is shown broken in Fig. 367 for the sake of space. The position of the rods 76 and 77, Fig. 367, can be adjusted laterally by means of the set-screws 83 and their lock-nuts.

At the other end of the rods 76 and 77 are the two squirrel cages (with their pins) 79; these have to be operated simultaneously by means of sliding catches, the back part of one of which is shown at 78. The method of operating these squirrel cages will be explained shortly; meanwhile, it will be seen that part of the cams P and Q, Fig. 361, is shown in Fig. 366. In addition, the bell-crank lever 18 and the rod 20, Fig. 361, are clearly visible in Fig. 366, and so is the spring N, Fig. 361. It will be remembered that it is this spring which acts on the clutch mechanism to stop the machine always at the same point of its angle or rotation.

Special and enlarged views of these two cams P and Q are shown in Figs. 368 and 369, where the solid black parts represent the recessed cams which operate the anti-friction bowls and their levers. Although both cams revolve in the same direction, the cam P is viewed from the belt side of the

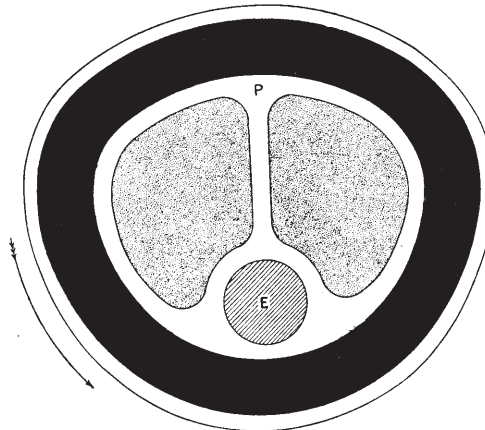

FIG. 368.

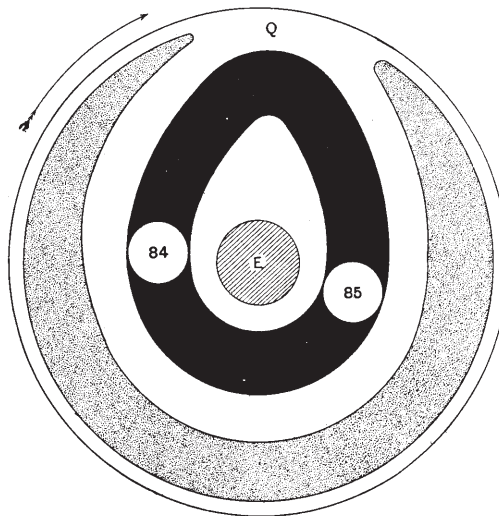

FIG. 369.

machine, whereas the cam Q is viewed from the other side of the machine. Hence, in Figs. 368 and 369 the directions of motion are counter-clockwise and clockwise respectively, as indicated by the arrows.

The position of the anti-friction bowl, which is operated by the cam P, is not shown in Fig. 368, but its position is plainly indicated by the number 17 in Fig. 360. Two anti-friction bowls are operated by the cam Q, Fig. 369, and the positions for these two anti-friction bowls are represented by numbers 84 and 85. The cam Q thus operates two different levers, one for moving the lever for the slide catches, and the other for moving the knife block or back heck, the part which operates the punches and so causes the

latter to perforate the sheet of paper at the proper places.

The mechanism by which the punches are operated to perforate the paper is illustrated in Figs. 370 to 373. When the cam Q rotates clockwise, as indicated in Fig. 369,

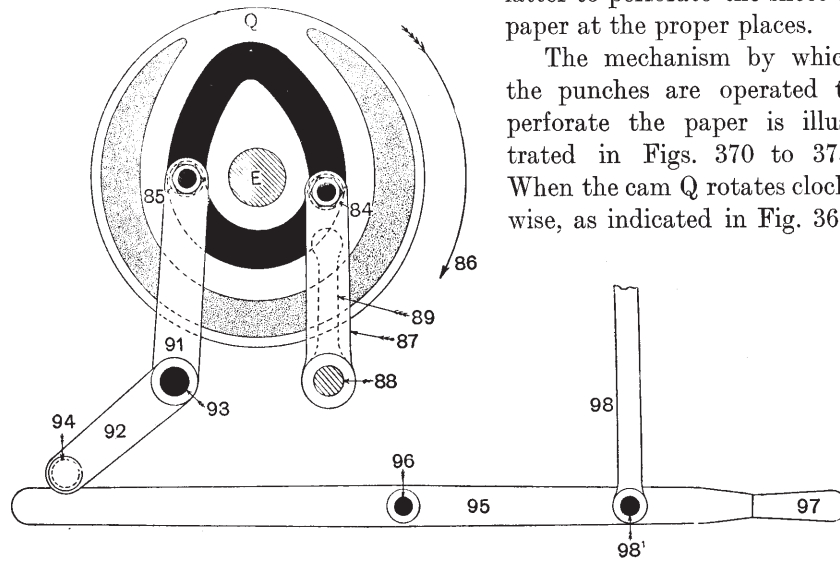

FIG. 370.

and when viewed from the frame side opposite the driving in Fig. 361, the box cam, shown in solid black, will force the anti-friction roller 84 to the right, Fig. 370, or towards the front of the machine, and will, in consequence, force the lever 87, fulcrumed on the rod 88, to the right. The rod 88 (see also Fig. 371) extends across the machine and carries two shorter levers, one only being shown at 89. The upper ends of these two levers 89 enter recesses in the knife block or back heck 90. The knife block is thus caused to move forward in its slides a short distance for each revolution of the cam Q. This movement effects the cutting of the paper—an operation which will be explained fully in connection with another drawing. Before describing this, however, it is advisable to explain that the same cam Q will, at a later moment of its rotation, also move

the anti-friction roller 85, Fig. 370, to the left. Hence, the levers 91 and 92, fulcrumed at 93, will cause the anti-friction roller 94 (see also plan view, Fig. 372) to act upon the left-hand end of lever 95, fulcrumed at 96. This lever is provided with a handle 97, which is clearly visible in the foreground of Fig. 366.

Referring now to Fig. 373, which is a detailed view of the corresponding parts in the foreground of Fig. 366, and viewed from the pulley side of the machine, it will be observed that the handle 97 of the lever 95 is placed similarly to the same part in Fig. 366, but at the opposite end to what obtains in Fig. 370. The lever 95 in Fig. 373 is shown only to a point a little beyond its fulcrum 96, but a full view is exhibited in Figs. 370 and 372. When the cam Q, Fig. 370, has made approximately half a revolution from its present position, it will impart movement to the levers 91 and 92, through the anti-friction bowl 85, and hence the left-hand end of lever 95 will be forced downwards and its right-hand part raised. Consequently, the flat rod 98, attached at 98¹ to lever 95, will be raised through a certain distance, and then brought back to the position indicated in the figure. Part only of the flat rod 98 is illustrated in Fig. 370; the function performed by it will be understood by reference to Figs. 366 and 373.

The flat rod 98, Fig. 373, moves vertically under the influence of the above-mentioned parts in the slides 99. At the upper end of the flat rod 98 (see Figs. 366 and 367) is fixed a stud 100, and upon its reduced end supports, swingingly, the two catches 78 and 78¹ (see Fig. 373). A brass plate 101 is fixed by screws 102 to the upper part or bridge-piece of the two catches 78 and 78¹, and from this brass plate 101 project two pins 103 and 104. A centre projection depends from the bridge-piece of the two flat rods 98, this depending piece being visible only in Fig. 366. A second stud 105, Fig. 367, is fixed to this depending piece, as shown in Fig. 366, and projects between the upper parts of the two arms of the catches 78 and 78¹. Upon the end of this stud 105 is placed the handle 106, Fig. 373, and held in position by the screw 107. This handle 106 is used to determine which of the two catches 78 or 78¹ shall act upon the pins 79, Fig. 367, of the squirrel cages or cylinders, the end-plates or discs 80 of which are adjustable, as shown in Fig. 373, by means of the slots 108

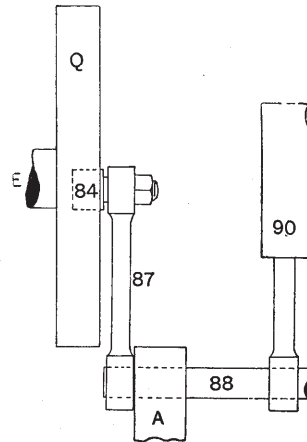

FIG. 371.

and the screws 109. A small flat spring 110 is secured by its upper part to the handle 106, while the inner side of the flat spring 110 is provided with a small dome-shaped projection adapted to enter into any one of the three small recesses 111, and so hold the handle 106 for the time being securely in any of the three positions.

The dome-shaped projection of the flat spring 110 is at present in the left-hand recess, with the handle 106 resting against the stop-pin 103. When the handle 106 is in this position, the right-hand lobe at the bottom and broad part of the handle keeps the right-hand catch 78¹ clear of the pins 79 of the cylinder in virtue of the hump 112, and at the same time the

left-hand lobe of the broad part of handle 106 allows the left-hand catch 78 to come into play against the pins 79. It will thus be seen that when the flat rod 98 is raised as explained, the two projecting parts of the catch 78 will simultaneously take hold of two pins 79, one in each cylinder, and rotate the cylinders one-ninth of a revolution

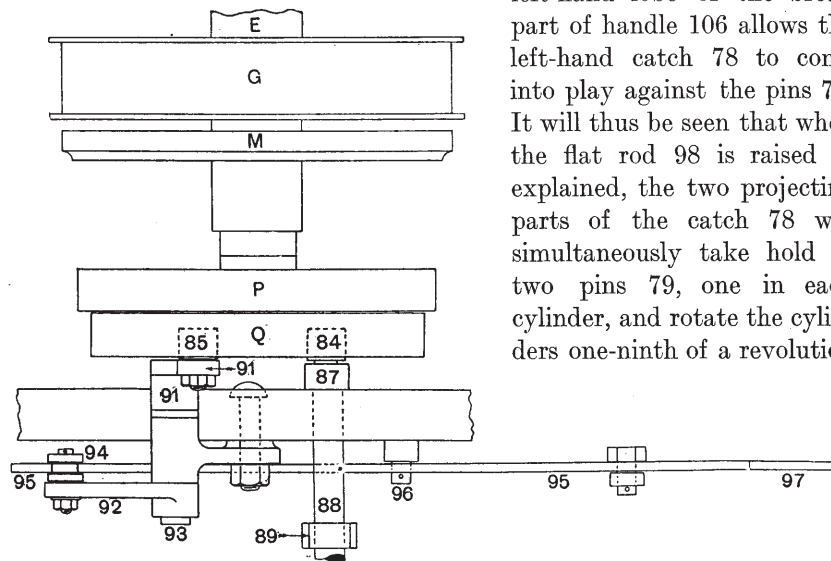

FIG. 372.

clockwise. This movement on the part of the two cylinders will draw forward the paper sheet, Fig. 366, a distance equal to the pitch of the cards, or, rather, the paper-strip equivalent of a card.

When the handle 106 is in the vertical position, as indicated by the dotted outline of the handle in Fig. 373, both catches are out of action. If, for any purpose, it is desired to reverse the direction of the paper, this may be done by placing the handle 106 in the right-hand position and against the stop-pin 104. The two catches 78 and 78¹ are joined by a spiral spring 113, which brings the active catch for the time being into position after it has been forced outwards during its downward movement by the pins 79.

Two bell-crank levers 114 and 115 (see also Fig. 366), fulcrumed respectively at 116 and 117, have the ends of their long arms joined by a

spiral spring 118. Rods 119 and 120 are attached by nuts to the bell-crank levers 114 and 115, and their forked ends 121 and 122 support, by means of pins, the bowls 123 and 124. These bowls rest between two of the pins 79, and serve as spring hammers to keep the two cylinders per-

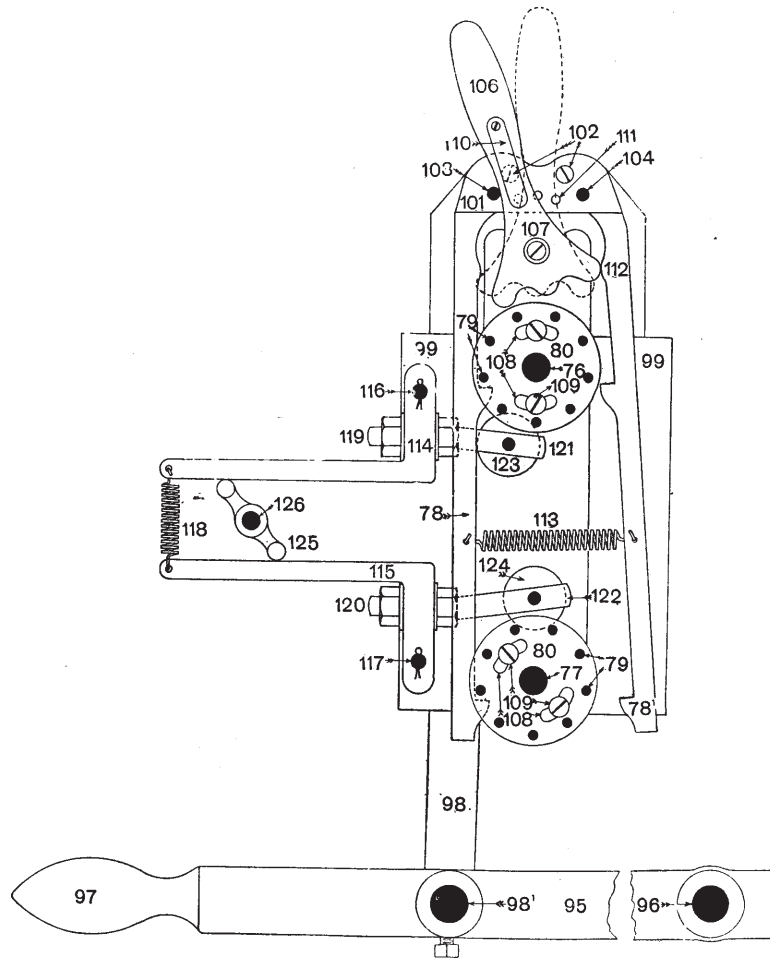

FIG. 373.

fectly stationary after they have been partially rotated as described. If, however, the short lever 125, fulcrumed at 126, be placed vertically, the long arms of the bell-crank levers 114 and 115 will be moved up and down respectively, extending the spring 118, while the short arms of levers 114 and 115 will be moved towards each other so as to withdraw the bowls 123

and 124 from contact with the pins 79, in which case the two cylinders may be rotated quite easily and thus enable the operator to withdraw the paper or move it forward quickly. Slight adjustments of the paper strip on the cylinders, in either direction, may be effected by means of the handle 97, Figs. 366, 370, and 373, provided that the proper catch 78 or 78¹ be placed into the active position.

The squirrel cages or cylinders are in duplicate, as illustrated in Figs. 366 and 367; the pins 79 of the outside pair are acted upon by the catches

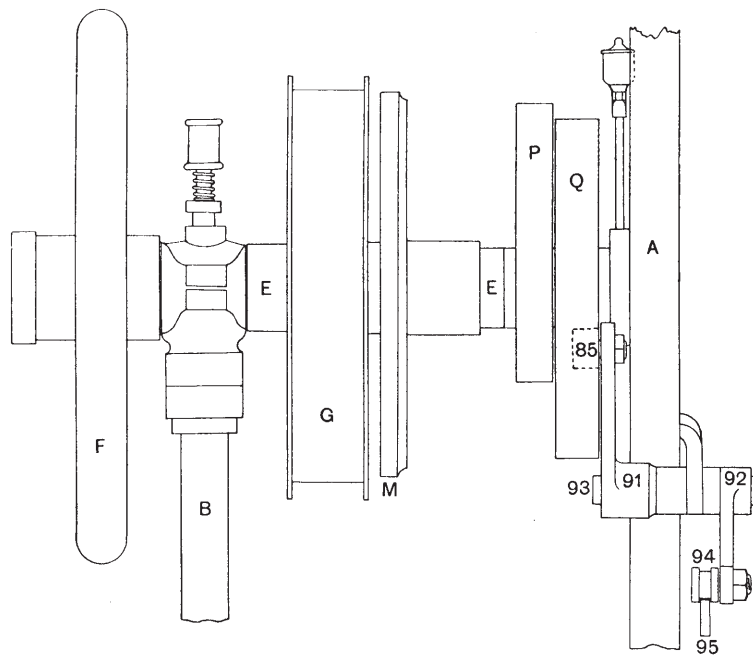

FIG. 374.

78 and 78¹, while the pins of the inside pair work in conjunction with the rollers 123 and 124, Fig. 373, of the spring hammers.

Fig. 374 illustrates the chief parts of the driving mechanism as viewed from the back of the machine; it also shows the positions of the two main cams P and Q, Figs. 368 and 369, and the back levers from the latter which operate the lever 95 fully illustrated in Figs. 370, 372, and 373.

Further details of the cams P and Q and their connections to the various levers appear in the plan view in Fig. 375. This view also shows the plan view of the peg wheels 75 with their covers, the front comberboard W, and a part of the back comberboard 44. The three large numbers 448 in the three divisions of the comberboard W show that the total capacity

of the machine is $448 \times 3 = 1344$ cords ; while the disposition of the holes in the comberboard is exhibited partly by two front and two back short rows of eight, and the complete front and back long rows.

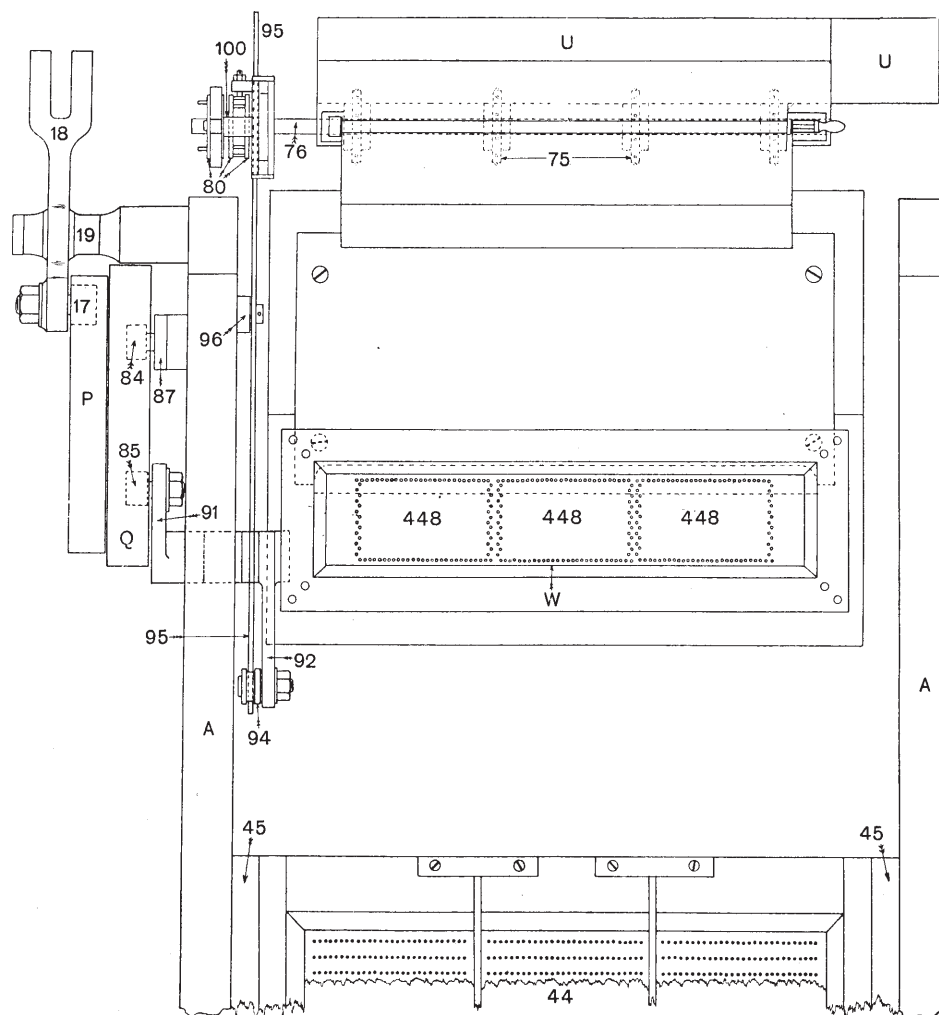

FIG. 375.

The holes in the front comberboard W are staggered as shown, whereas the holes in the back comberboard 44 are in straight rows in both directions. Between each pair of long rows in the back comberboard 44 is a glass rod (see 43, Fig. 376 and Fig. 362). In Fig. 376 a small part only of the comberboard 44 is shown, while immediately above this plan view is an elevation

of the back of the comberboard 44 with the parts 127 and 128 which serve as supports for the series of glass rods 43. This view also exhibits the arrangement for supporting the bottom heck 46 and 47, the latter heck being used as a guide for the flat lingoës (see Fig. 362).

We shall now illustrate the method of operating the punches which pierce the paper strip illustrated on the left of Fig. 366. It has already been shown in Fig. 362 that the cords 41 pass through the front comber-

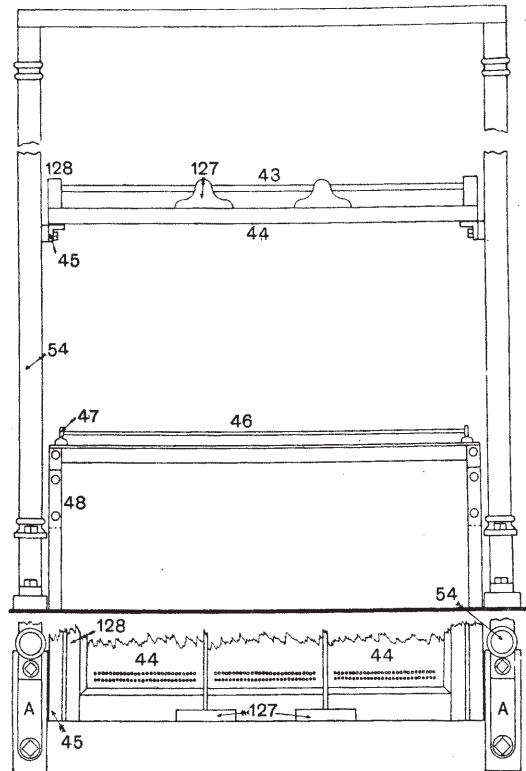

FIG. 376.

board W, and that the lingoës 42 are attached to their lower ends. The comberboard W is reproduced on a larger scale in Fig. 377, and sixteen cords 41 descend to the lingoës 42, part of the length only of which is illustrated.

Eight of the cords 41, Fig. 377, are shown in rope form, and eight are in line work; this distinction is to show that the cords form two of the staggered rows (see plan view, Fig. 375); they are also drawn much thicker than they actually are. The harness cords 41 pass between two brass plates 129 and 130. Each of these plates contains as many holes as there are harness cords 41 in the comberboard W—*i.e.* 1344

—and the disposition of the holes in the plates 129 and 130 is exemplified by four complete rows in each case in Fig. 378. The two plates are secured to the block 131 (see Fig. 379), and this block, in conjunction with a similar block at the opposite side of the machine, provides the slides for the sliding blocks 132.

The back parts of the sliding blocks 132 are held by the knife block or back heck 90, Fig. 377, and may be adjusted to position, horizontally and vertically, by the screws and lock-nuts. At the front of the sliding blocks

132 is the needle plate 133, the function of which will be explained shortly. Part of the rear of the back heck 90 is shown in Fig. 380.

The two sliding blocks 132 and the back heck 90, Fig. 377, are moved

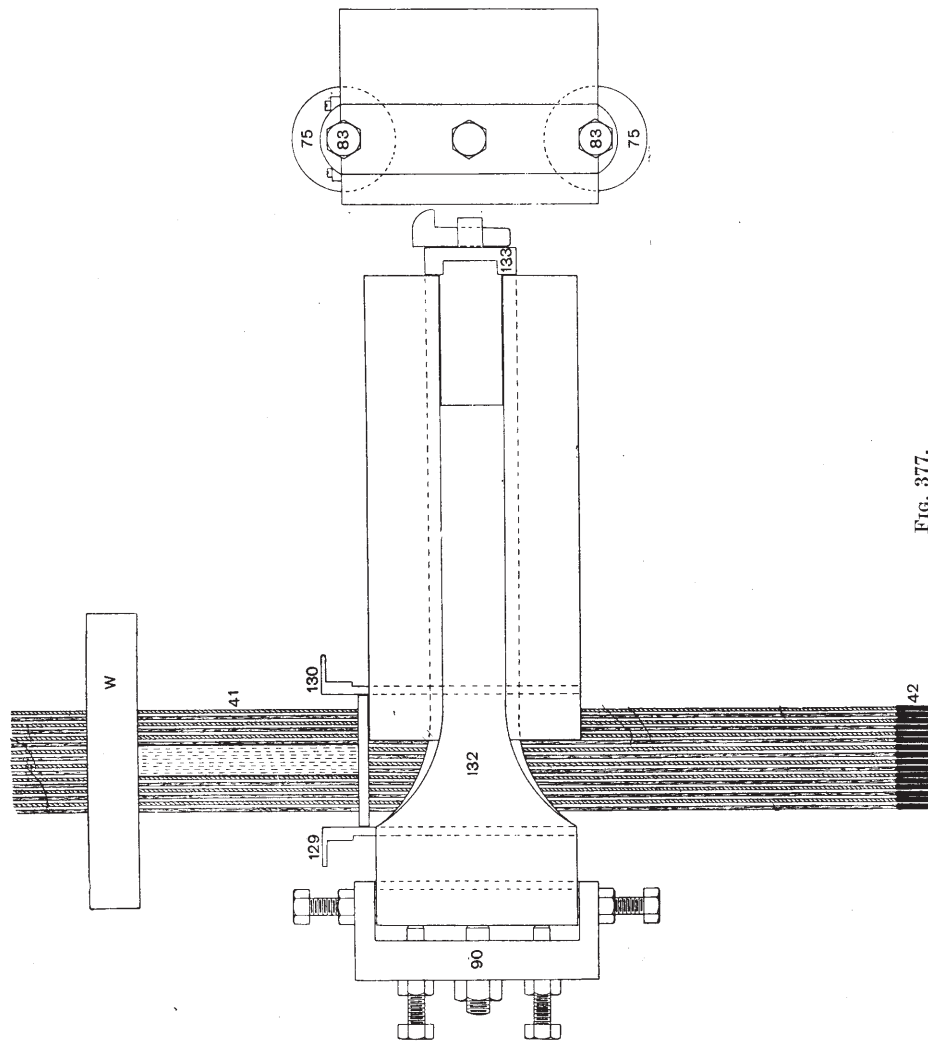

Fig. 377.

through a short distance by means of the mechanism illustrated in Figs. 370, 371, and 372. The upper part of the short lever 89 enters a recess in the knife block or back heck 90, so that as the cam Q rotates as indicated by the arrow the back heck 90, Fig. 377, is first moved to the right and then back again. These two motions obviously take place every revolu-

tion of the cam Q, Fig. 370. The knife block or back heck 90, Fig. 377, is shown in section in Figs. 381 and 382, but the adjusting screws are omitted. It will be seen that there are 16 short knives 134, the outer end of each of which has a <-shaped recess. Sixteen punch needles 135 are bent as shown, and their extreme left-hand ends are <-shaped. The extreme right-hand ends of the punch needles 135 are supported by the

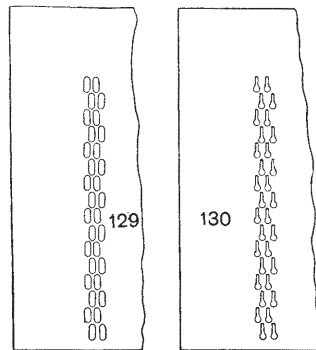

FIG. 378.

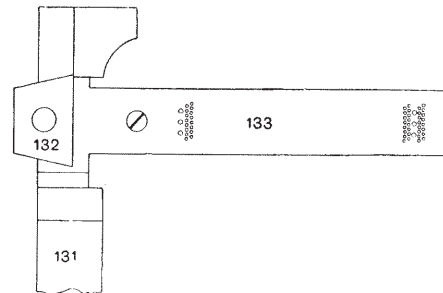

FIG. 379.

needle plate 133, while the left-hand ends are supported by the brass plates 129 and 130. The punch needles 135 are kept in their proper positions by the slots above the holes in plate 130, Fig. 378.

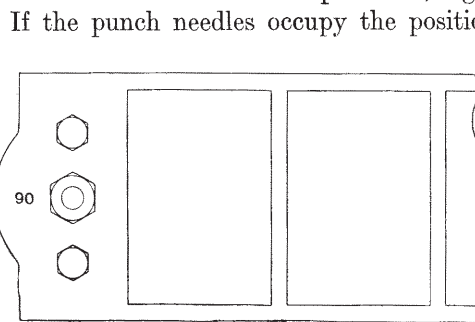

FIG. 380.

If the punch needles occupy the positions indicated in Fig. 381, the short knives 134, when carried forward by the back heck 90, will push the punch needles 135 to the right. Eight of the punch needles 135 are shown complete in this figure, but the remaining eight are cut off because of the difficulty of illustrating all the sixteen in the needle plate 133.

The actual punches 136 are located in the plates 137, and the small ends of the punch needles 135 are exactly opposite the heads of the actual punches 136, while the paper strip 138 to be cut passes between the right-hand plate 137 and the punch plate 139.

In Fig. 382 the <-shaped ends of two punch needles 135 occupy positions opposite the spaces between the knives 134, while the three lower punch needles are opposite the <-shaped ends of the knives 134. The

knife block 90 is supposed to have moved to the right until the knives 134 and the punch needles 135 are almost in contact. Any further movement of the knife block and knives to the right will cause the lower three punch

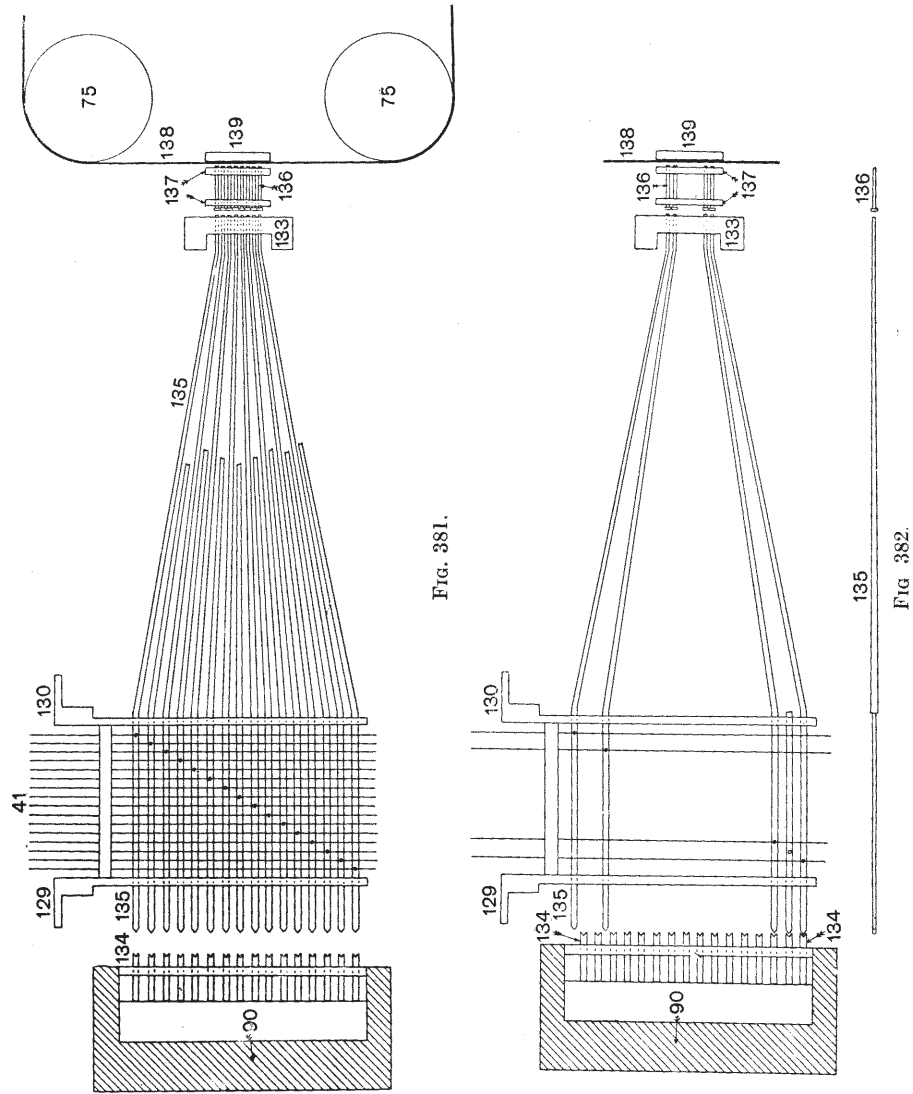

needles to be pushed to the right, and their small right-hand ends would, consequently, push forward the actual punches 136, the cutting ends of which would pass through the paper strip 133 and into the fixed punch plate 139.

The left-hand ends of the two upper punch needles 135 would, simultaneously, enter between the knives 134, and these two punch needles would remain undisturbed, and so would their respective actual punches 136. It will thus be clear that the paper strip 138 would be cut at those points represented by the sliding movement of the punch needles 135, whereas blank or uncut portions of the paper strip would appear opposite those punch needles which are not actuated by the knives 134. A plan view of one of the punch needles 135 is shown detached at the bottom of Fig. 382.

The action of the selecting mechanism is as follows: The pilot paper 61, Fig. 363, effects the selection of the vertical needles of the Verdol jacquard, so that all hooks actuated by the horizontal needles of the jacquard, due to the selective agency of the short vertical needles, will be raised or left down according to whether holes or blanks appear on the pilot paper 61. Those hooks which are raised, due to holes in the pilot

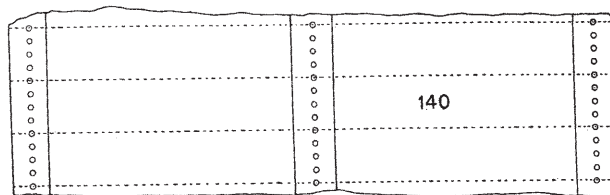

FIG. 383.

paper, raise the corresponding harness cords 34 (see Fig. 362), together with their lingoes 37. The upward movement of a lingoe 34 enables the corresponding lingoe 42 to descend and to take up the slack harness 38 as demonstrated. Hence, the harness cord 41, Figs. 377 and 381, would descend.

In Fig. 381 it is assumed that all the cords 41 illustrated have descended to their lowest position, and that this action was due to the fact that two rows of eight, or sixteen holes in all, appeared in the pilot paper 61, Fig. 363, and that consequently, when the corresponding 16 harness cords 34 were raised, the 16 harness cords 41, Figs. 362 and 381, would descend, because the upper and lower stretches of harness cord are attached to the punch needles 135, a hole being left in the needle purposely to enable the harness cords to be attached to the punch needle. When the 16 harness cords 41 descend, the <-shaped ends of all the 16 punch needles 135 will descend and occupy the position as illustrated immediately opposite the <-shaped ends of the knives 134. Under such conditions, all the 16 punches would be pushed to the right, and 16 actual punches 136 would

be forced through the paper strip 138, so that the repeated paper would be identical with the pilot paper 61 in these two rows, and, of course, in all the other rows according to the blanks and holes in the pilot set.

When the paper strip is placed on the pegs of the cylinders 75 it contains peg-holes which correspond to those which the dotted lines cross in the paper strip 140, Fig. 383. These holes are necessary to enable the uncut paper strip to be carried intermittently forwards or backwards, as the case may be, by the catches 78, Fig. 373.

Special punches, similar to that shown at 141, Fig. 384, have three punches which are utilised to punch three successive holes in each of the three reinforced strips of each card equivalent. These three holes, or nine altogether in each card section, are cut simultaneously with the holes for the design. It will be understood that three of these triple punches 141 are always in position for two of the knives 134, Fig. 381, to push the punches forward for every card. If for any reason the triple punches are required to be out of action, they may be raised so that the two <-shaped prongs on the left of 141, Fig. 384, may enter between the

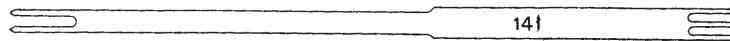

FIG. 384.

knives 134, Fig. 381. This withdrawal of the triple punches is accomplished by the parts 81 and 82, Fig. 361.

One of the latest fine-pitch repeating machines for endless paper cards is that illustrated in Fig. 385. It occupies much less space than the machine just described, and has the distinct advantage of being without harness cords of any kind.

The pilot set of cards, or, rather, endless paper, is cut as usual on the fine-pitch piano machine. The paper strip upon which the duplication has to be made is shown at 138, Fig. 386. This part of the machine is practically identical with the corresponding part in the foregoing machine, and the method by means of which the operation is performed is demonstrated in the sectional view of the chief parts in Fig. 386.

The pilot endless strip of paper 61, instead of being placed over the cylinder 62 and the cover 70 of a fine-pitch jacquard, as in Fig. 363, is passed over a similar cylinder 62, Fig. 386. In the latter case, however, the cylinder not only rotates, but is raised and lowered for each card equivalent. The paper strip is held in position by the usual pegs on the cylinder 62, and passes over the cover plate 70 so as to clear the ends of the vertical needles 142. Two vertical needles only are shown, but it will be understood that there are 16 in two staggered rows to correspond with

the cards, etc. Each vertical needle 142 controls a horizontal presser rod 143, the right-hand end of which is provided with a head to come, when required, into contact with the left-hand end of its corresponding punch needle 135. The right-hand ends of the punch needles are adapted, when moved, to strike the heads of the actual punches 136, and to force

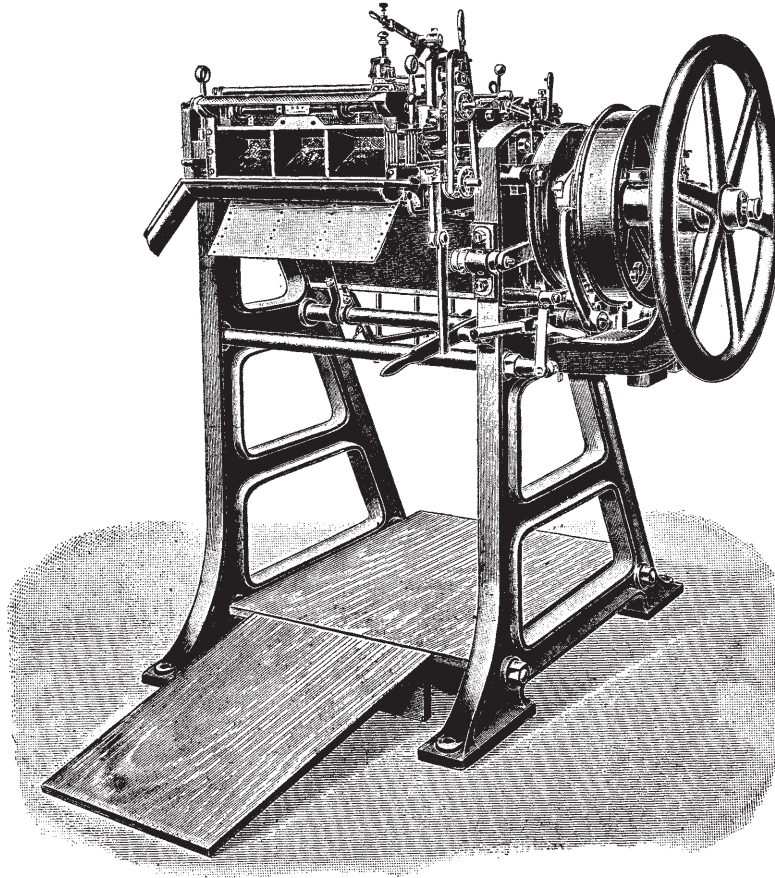

FIG. 385.

them through the paper strip 138 which is in process of being duplicated according to the holes and blanks in the pilot paper strip 61.

As illustrated in Fig. 386, the vertical needles 142 are in their lowest positions, being supported in that position for the time being by the hooks at their upper ends and the hook-rest 144. When the cylinder 62 has been turned to place a new card equivalent under the lower ends of the vertical

needles 142, the cylinder 62 and paper 61 are raised until the card equivalent of the paper is gripped between the cover 70 and the grid 145.

If two holes in the pilot card happened to be opposite the two vertical needles 142, illustrated in Fig. 386, the ends of the vertical needles would pass through the holes in the card 61, and the vertical needles would remain undisturbed. Then, when the back heck 90 with its knives 134 was forced to the right, the knives 134 would push forward the presser rods 143, and the heads of the latter would, in turn, push forward the punch needles 135, and ultimately the actual punches 136 would be forced through the paper strip 138 and into the holes of the punch-plate 139.

If, on the other hand, blanks in the paper strip 61 appeared under the lower ends of the vertical needles 142, the latter would be raised, and their

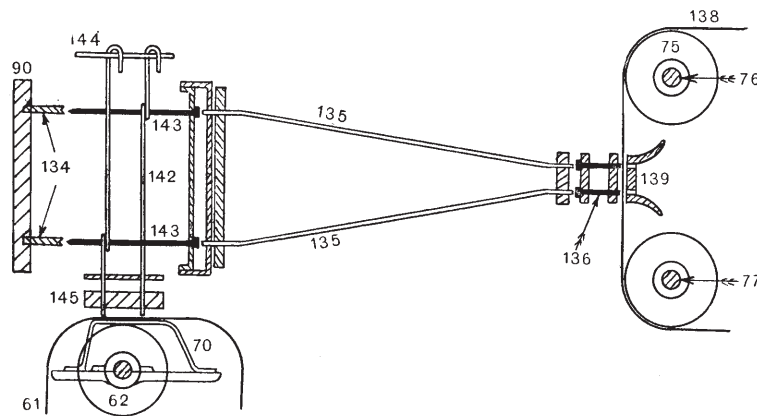

FIG. 386.

loops or bends would raise the left-hand ends of the presser rods 143 and thus would take them out of the path of the knives 134 as the latter were advancing.

A considerable number of designs which are prepared for the fine-pitch repeating machines, and also by the fine-pitch piano card-cutting machine, are intended for the twilling jacquard looms. As a matter of fact, fine-pitch jacquard machines are rarely used unless the unit pattern contains a very high number of threads. It need hardly be said, however, that the use of these fine-pitch machines always means economy at least in the weight of paper used. But, speaking generally, the designs on 200 to 600 hooks and needles are produced most largely in these islands by means of the ordinary-pitch, *i.e.* British-pitch, jacquards. The development of patterns on, say, 1800 to 2400 needles by British-pitch machines means a considerable outlay in paper cards; and if the twilling jacquards were not used for such patterns, the outlay would be enormous,

and probably prohibitive for the bulk of these high-class figured textile fabrics.

For the flat treatment of designs, say damasks woven in twilling jacquard looms, there need not be any weave inserted on the design paper ; hence, the cutting is comparatively simple, and so is the repeating. On the other hand, the weaves which can be used, and inserted mechanically by the twilling jacquard, are limited, and really restricted to two, unless some slight mechanical alteration is made in the machine itself.

In the silk trade it might be advisable to use a certain fixed type of ornamentation on a number of different fabrics, and in each case to alter the weave in the figure as well as the weave in the ground. Where such treatment is anticipated or desired, a machine similar to that illustrated in Fig. 387 would probably be useful. In general appearance this machine appears very similar to that illustrated in Figs. 357 and 358 ; while the jacquard on the right of the machine in Fig. 387 is identical with that in Figs. 357 and 358, and shown independently in Figs. 359 and 363.

There is only one jacquard in the machine illustrated in Figs. 357 to 363, but in Fig. 387 there are two jacquards mounted on the framework and connected by harness cords, as shown, to the lower parts of the repeater. The left-hand machine is a 600's coarse-pitch jacquard.

The two jacquards in Fig. 387 may work in unison, as will be explained shortly, or they may work separately. Thus, if an endless set of paper cards, which has been punched on the fine-pitch piano machine, required to be copied or repeated, the endless set would be placed over the cylinder of the fine-pitch jacquard on the right. The machine would then be started and the repeating process would be identical with that described in connection with Fig. 362. If, however, it is desired to make a fine-pitch endless paper duplication of a set of ordinary 600's jacquard cards, the latter are placed over the 4-sided cylinder of the coarse-pitch jacquard on the left of Fig. 387. The harness cords from this machine are attached to the lingoos in the large frame, and hence, when they are lifted, the oblique cords would be lifted as well, or rather slackened, and the front punches would take up this slack and thus place the cutting or punching apparatus into the desired position for duplication on the endless-paper cards.

The machine in Fig. 387 is thus capable of repeating fine-pitch sets of paper either from a similar fine-pitch set or from an ordinary coarse-pitch set. And, if necessary, a third machine, say a medium-pitch machine of the Vincenzi type, could be placed alongside the two in Fig. 387, and then fine-pitch duplications could be made from any of the three distinct sets mentioned, or from any other pitches, provided that the corresponding jacquards were mounted on the frame of the repeater.

But to return to our first consideration of endless-paper cards cut from designs on which no weaves occur, but which are composed of solid-painted masses and unpainted areas. This endless-paper set of cards could, naturally, be used as a pilot set for duplication by placing it, as already mentioned, on the cylinder of the right-hand jacquard in Fig. 387.

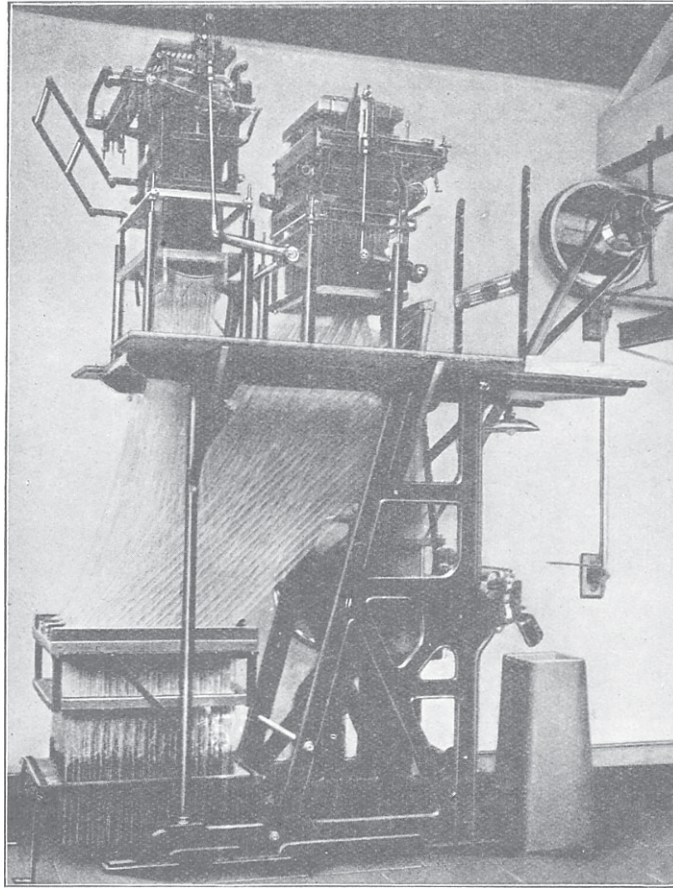

FIG. 387.

The resulting set would be suitable for a twilling jacquard loom weaving common harness damasks, for certain kinds of quilts if a fine-pitch machine could be adapted for such work, and for similar fabrics where the weaves are inserted into the cloth by special mechanism or apparatus independently of the jacquard cards.

In addition to its faculty for the above work, the repeating machine

illustrated in Fig. 387 is adapted for producing full-harness designs on an endless sheet from a similar endless sheet which has been punched from a weaveless point-paper design.

Fig. 388 is a sectional and partly diagrammatic view of the essential cords, lingoos, etc., in the machine illustrated in Fig. 387. In the former figure several of the parts are practically identical with the corresponding parts of the Verdol fine-pitch repeater, and particularly with reference to Fig. 362 and Figs. 377 to 384. The extra parts which appear in Fig. 388 are the diagrammatic indication of a coarse-pitch jacquard on the upper left-hand side of the illustration, and the looped cords below the back heck 44. The back lingoos in Fig. 388 are marked 37^1 , instead of 37 as in Fig. 362; but this is because the former fulfil a more extended function than the latter. The dotted area between the top and bottom front comberboards W and W^1 represents the right-hand ends of the punch needles 135, which in reality taper, as shown in Fig. 381, but in the opposite direction, towards the needle plate 133, in order to occupy the narrow limits at the points where the latter pierce the paper strip 138.

The object desired in the machine and diagram illustrated in Figs. 387 and 388 is to cause the vertical harness cords 41 to fall a short distance only when both cords 146 and 34 are raised by the two jacquards. This is accomplished by the method of connecting the cords to the bottom lingoos 37^1 . In the somewhat similar arrangement for the Verdol fine-pitch repeater (see Fig. 362) it will be found that there are only 16 back lingoos in a short row; in Fig. 388, however, there are 32 back lingoos. For each group of three cords, 38, 146, and 34, Fig. 388, there are two back lingoos 37^1 .

The arrangement of all the cords to the necessary parts is shown in full in Fig. 388; but in virtue of the necessary photographic reduction it will be difficult to follow all the parts distinctly, and especially those below the back heck 44. Hence a much-enlarged view of one group of cords, with the diagrammatic attachments, is introduced in Fig. 389. These three cords, 38, 146, and 34, are distinguished in the latter view by different kinds of markings, and part only of the length of each lingoo 37^1 is shown.

It will be seen that the central cord 38, Fig. 389, is attached to a ring 147, and passes upwards through the back heck 44, between the glass rods 43, and then direct to the end 39, Fig. 388, of the wire link Z in the frame X. The two cords 146 and 34 are shown as passing through holes in the upper parts of the back lingoos 37^1 , Fig. 389. In reality the cords will be tied to the lingoos. A second and shorter cord from each, and distinguished by the same markings, is also tied or hooked to the back lingoos 37^1 and to the ring 147.

If either cord 34 or 146, Figs. 388 and 389, be raised alone, it has no effect upon the vertical movement of the ring 147; but if both cords 34

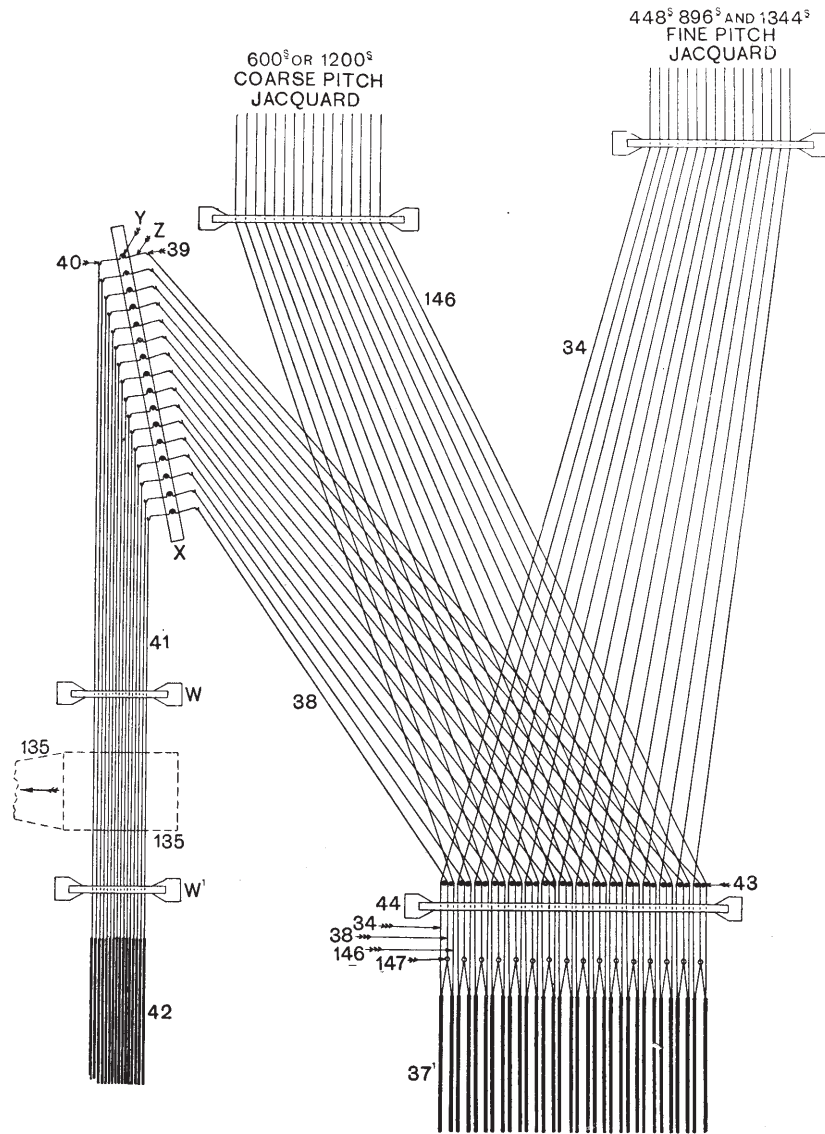

FIG. 388.

and 146 be raised simultaneously, the cord 38 and the ring 147 will be slackened, due to the raising of two adjoining back lingoos 37', and hence

the corresponding front lingoe 42, Fig. 388, will descend to take up the slack in cord 38, and will thus lower slightly the corresponding punch needle 135, so that its >-shaped end (<-shaped in Fig. 381) will be placed in the path of the moving grid 134.

It will be understood that arrangements must be made for the same number of cords in the group 146 as in the group 34, otherwise the two machines could not work satisfactorily. It does not follow that the two jacquards should have the same number of hooks, but it is clear that, whatever kind of repeating is done, it must be accomplished without break of pattern or break of weave.

Suppose, then, that a design, to all appearances a common-harness design, has been punched on the fine-pitch repeating machine, the endless-paper cards cut from this design can be used for the purpose of duplication. If, however, a full-harness design of precisely the same ornamentation and number of needles (not hooks) were required, the endless-paper cards for this full-harness design could be punched on the repeating machine illustrated in Figs. 387 and 388 by the aid of the common-harness endless-paper cards.

The common-harness endless-paper cards would be placed on the circular cylinder of the fine-pitch jacquard on the right in Figs. 387 and 388, and this endless set would control the actual ornamentation according to the design; the weaves, however, which are necessary for the full-harness design would be introduced on to the full-harness endless-paper cards by means of the coarse-pitch jacquard on the left in Figs. 388 and 387.

Suppose, for example, that in the full-harness set it were desired to have the 5-thread sateen weave in the ground of the design, and the 8-thread sateen for the figure of the design. A set of cards punched with the $\frac{7}{1}$ sateen weave is placed on the four-sided cylinder of the

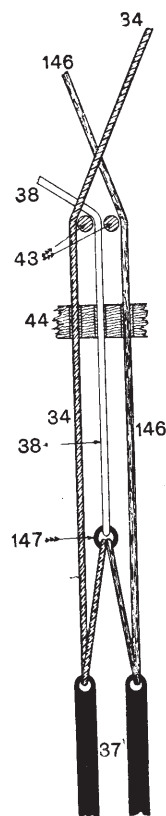

FIG. 389.

coarse-pitch jacquard. Since the figured portion on the common-harness endless-paper cards is in more or less large areas, it follows that every hook in the figure portion in the fine-pitch jacquard will be lifted; simultaneously, seven hooks out of every eight of those in the coarse-pitch jacquard will be lifted; hence, every eighth cord 146, Figs. 388 and 389, will be left down. And, although the corresponding cord 34 is raised by the fine-pitch jacquard, the corresponding cord 38 will not be raised. Consequently, seven holes will be cut and the next place uncut on the endless paper

which is being repeated. The full length of the paper will be treated until the last card of the common-harness design has been repeated as a full-harness design, so far as the figure portion is concerned.

It now remains to introduce the 5-thread sateen, $\frac{1}{4}$, into the ground or unpainted area. The common-harness endless-paper cards which have been used as a pilot set on the fine-pitch jacquard in Fig. 388, and the repeated endless-paper cards, are now reeled back until each is placed with No. 1 pick opposite the needles and punches respectively. Then a set of coarse-pitch cards punched with the $\frac{1}{4}$ sateen weave is placed on the cylinder of the coarse-pitch jacquard; but before the operation can be completed it is necessary to cause the ordinary needles of the fine-pitch jacquard to work negatively instead of positively.

When the jacquard is working positively—*i.e.* normally—the hooks 1, 2, Fig. 390, are under the control of the ordinary jacquard needles 146. The latter, however, are not acted on directly by the cards as in the ordinary jacquard, but by a corresponding number of supplementary needles 147. Each of the latter is provided with a disc at the left-hand end, whilst its right-hand end is supported by the horizontal arm of a steel presser blade 148. And each supplementary needle 147 is encircled by a vertical needle or feeler 149. The upper ends of the feelers 149 are bent to enable them to be supported by a specially formed grate 150 (see plan view and also an enlarged view to the left of the latter in Fig. 390). The grate 150 limits the downward movement of the feelers 149. The lower ends of the feelers 149 pass through holes in the double grate 29.

It will be seen that there are seventeen of the steel presser blades 148, the outer end of each of which is bent downwards as shown, and the whole group arranged to form a grate. The position occupied by this grate of blades is indicated at 148 in Fig. 363 at the end of the slide 59. As the slide 59, Fig. 363, moves outwards, due to the action of the parts 25, 55, 56, and 58, the grate 148 at the end of 59 is raised slightly because of the action of the oblique slot 60 on the fixed pin. This upward movement of the part 59 raises the feelers 149, Fig. 390, clear of the endless paper 61. As the griffe 27, Fig. 363, descends, the grate of blades 148 moves inwards, and the bottom ends of the feelers 149, Fig. 390, pass through the double guideplate 29; those feelers which are arrested by blank parts in the endless pilot set remain in the high position, thus placing the right-hand ends of the corresponding supplementary needles 147 in the line of the downward-bent portion of the steel presser blades 148 (see dotted position of one supplementary needle 147 in Fig. 391). On the other hand, those feelers 149, Fig. 390, which pass through holes in the pilot endless paper place the right-hand end of the corresponding supplementary needles 147 opposite the gaps between the steel presser blades 148, Fig. 391. As the

presser blades 148 move nearer to the feelers 149, Fig. 390, some of the supplementary needles 147 will be pushed to the left, and the discs on their ends will move the ordinary needles 146 to the left, and thus take hooks 1, 2, etc., off the knife 27¹ of the griffe, while other supplementary

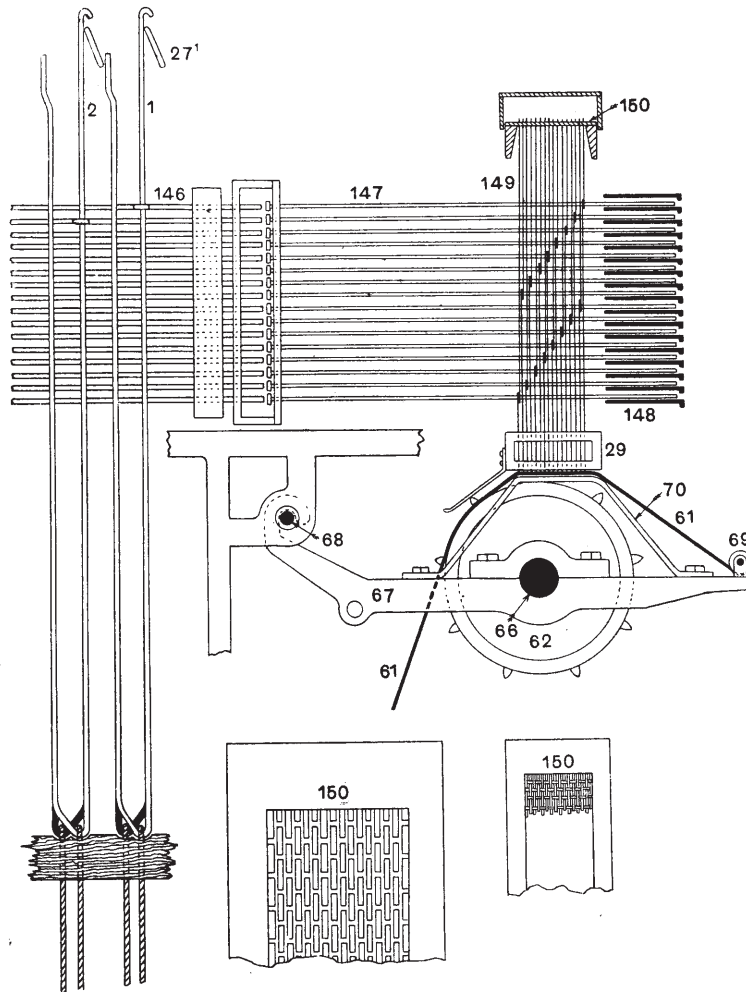

FIG. 390.

needles 147 will pass undisturbed through the gaps near the right-hand ends of the steel presser blades 148, Fig. 391, as the latter are moving inwards; the corresponding hooks 1, 2, etc., Fig. 390, will therefore be raised by the knives 27¹. All the feelers 149 are arranged in a constant pitch; in Fig. 392, however, the circular bends in the

feelers 149 are enlarged slightly in order to show the arrangement better.

Such is the action which takes place when the figure of the design is being cut and while the $\frac{1}{4}$ sateen is being inserted in the figure portion of the repeated endless paper. But to make the fine-pitch jacquard, Fig. 388, work negatively, the steel presser blades 148, Fig. 390, must be inverted as indicated in Fig. 393. Then the holes in the pilot set of endless paper would result in the feelers 149

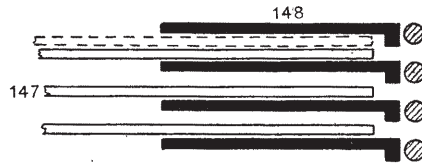

FIG. 391.

occupying the low position as usual, but the upward-bent parts of the steel presser blades 148 would push the supplementary needles 147 to the left, and hence leave blanks in the repeated full-harness sets of paper.

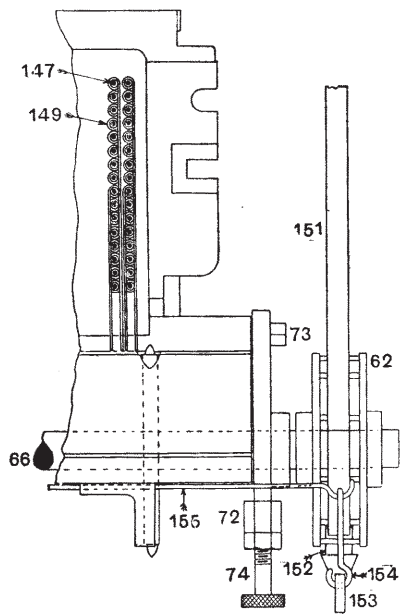

FIG. 392.

Simultaneously, the blanks in the pilot sets of endless cards would cause the ends of all the corresponding supplementary needles 147 to be placed opposite the gaps of the steel presser blades 148, as shown by the dotted supplementary needle in Fig. 393, and therefore all the corresponding hooks, Fig. 390, and cords 34, Fig. 388, would be raised. Now the $\frac{1}{4}$ sateen cards on the cylinder of the coarse-pitch jacquard in Fig. 388 would act in the ordinary way, and would leave down four hooks out of every five. Hence, although every cord 34, Fig. 388, in the ground portion is raised, there is only one cord 146 out of five raised by the coarse-pitch jacquard, so that only one out of five is cut, seeing that two cords (one 34 and one

146) must be raised to cause the corresponding cord 38 to yield.

Apart from the intricacies of the machine illustrated in Figs. 387 to 393, it will be observed that a defect obtains in that both the ground and the figure weaves are introduced mechanically on to the paper, and thus modifications on the contour of the figure and the adjacent parts of the

ground receive no special treatment. In connection with certain decorative fabrics it is well known that when the weaves are introduced by hand on to the design-paper, the edges of the ornament can be treated so as to yield much more satisfactory results in the cloth than it is possible to obtain by any direct mechanical, electrical, or photographic treatment. On the other hand, there are fabrics in which the above-mentioned treatment is not essential, in which case the machine illustrated in Figs. 387 to 393 appears to be quite suitable.

When the above machine is utilised for repeating purposes pure and simple, the operation can be performed, as already stated, from either long lengths of thin paper (fine Verdol pitch) or from thick cardboard cards of the ordinary type and, of course, of the pitch corresponding to the coarse-pitch jacquard, Fig. 388. If thick cardboard cards are used they would naturally be placed on the square cylinder of the coarse-pitch jacquard on the left-hand side in Fig. 388, and all the hooks of the fine-pitch jacquard

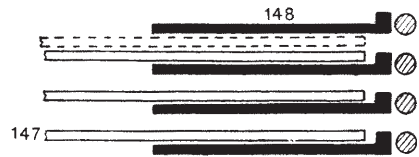

FIG. 393.

on the right of the same figure would be held up while the cutting operation was being performed on the long length of thin paper. Conversely, if the repeating process is from a long length of thin paper as in the fine-pitch jacquard on the right of Fig. 388,

all the hooks of the coarse-pitch jacquard on the left would be held up during the repeating process.

The reading-in frames, or "simples," as they are termed, are used in connection with certain machines similar to that illustrated in Figs. 357 to 393, with the object of performing the work, as already stated, without employing a piano card-cutting machine. In this case, however, the simple consists of a number of rows of cords to correspond exactly with the disposition of the rows of the cords in the jacquard—*e.g.* 16 per short row. Before commencing with the selections for the cross cords similar to C and D, Fig. 159, it is usual to pick a thread-and-thread lease of all the vertical cords in the 16 rows, and this operation, as well as that of inserting the cross cords, is not usually performed at the actual cutting machine, but at some more convenient place. When the lease is picked, and two lease rods are inserted, the arrangement is very similar to that illustrated on the extreme right of Fig. 394, where the two lease rods are numbered 156; eight cords only are shown at 157. Provision is made, however, at the upper end of cords 157 to prevent them from becoming displaced; thus the upper end of each cord is made in the form of a loop, and the loop is held by short bars in the reading-in frame. The lower ends

of the vertical cords 157 are attached in a suitable manner to the beam 158, which is held securely by means of a ratchet wheel on the end and a retaining pawl, not shown, but loosely pivoted on a stud in the frame A.

When the simple has been provided with the cross cords as explained

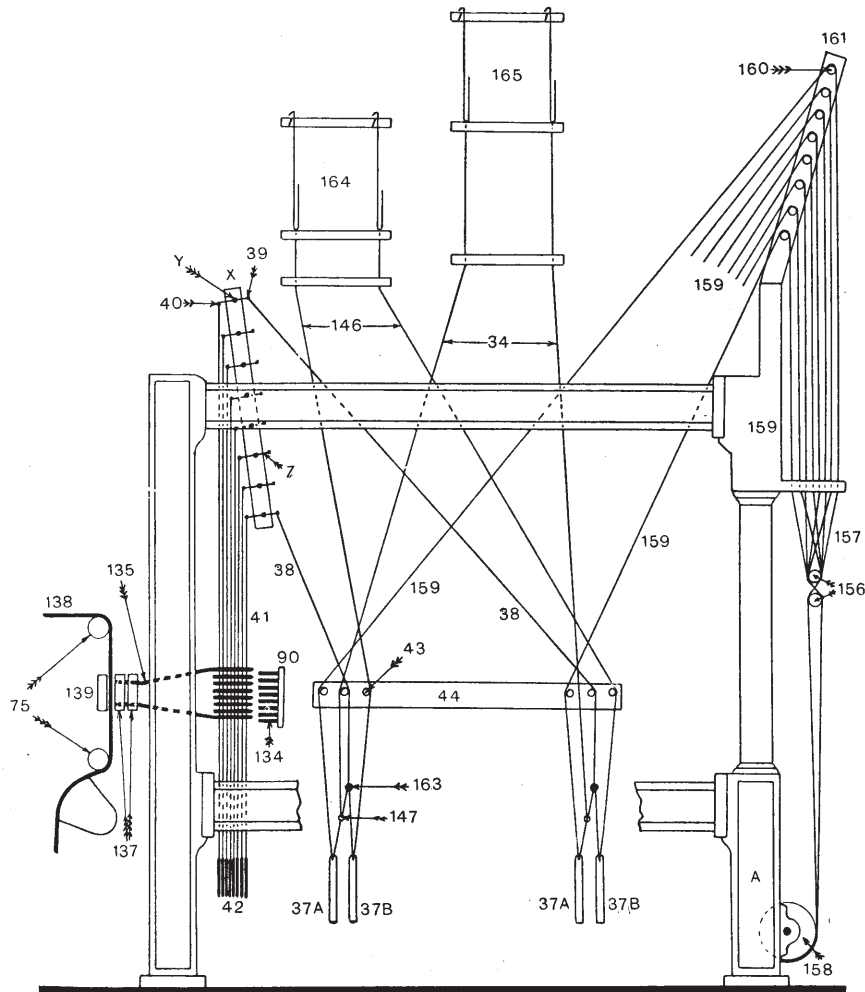

FIG. 394.

in connection with Fig. 159, the simple is taken to the machine illustrated in Fig. 394 and attached as indicated therein. The cords 38, 146, and 34 are attached to the same parts as the similarly numbered cords in Figs. 388 and 389. In Fig. 394, however, there is an extra series of cords 159 which pass over the pulleys 160 housed in the oblique pulley box or frame

161. These cords, the number of which also corresponds with the number of needles in the jacquard, descend as indicated towards the upper ends or loops of the simple cords 157 ; indeed, the loops of the latter are suspended on hooks at the ends of the cords 159. The lease rods 156 would be removed, and then the cords 157 made taut by rotating the beam 158 clockwise.

Of each short row, or rather half-row, only the first and last cords, 38, 146, 34, and 159, are illustrated in Fig. 394, but all the 16 cards in each complete short row are shown in Fig. 395, in addition to the uniform tensioning cords and lingoes 162. This figure also shows a considerable part of the mechanism, while Fig. 396 is a front view of

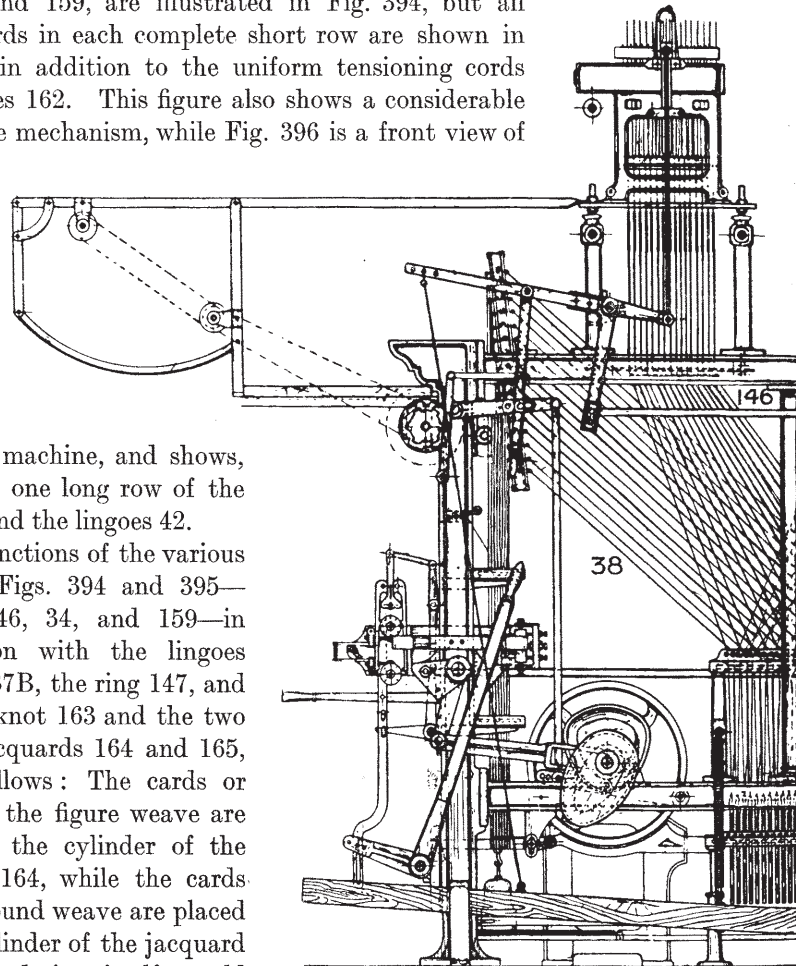

FIG. 395.

the same machine, and shows, *inter alia*, one long row of the cords 41 and the lingoes 42.

The functions of the various cords in Figs. 394 and 395—*i.e.* 38, 146, 34, and 159—in conjunction with the lingoes 37A and 37B, the ring 147, and the large knot 163 and the two 16-row jacquards 164 and 165, are as follows: The cards or paper for the figure weave are placed on the cylinder of the jacquard 164, while the cards for the ground weave are placed on the cylinder of the jacquard 165. The design itself would appear in solid painted masses and solid unpainted areas as represented by the design in Fig. 159, but, of course, on a much larger size of paper. As already mentioned in connection with Fig. 159, the horizontal or cross cords pass under and over the

vertical cords in orders which depend upon the lengths of the unbroken floats of figure and ground, or *vice versa*, according to circumstances.

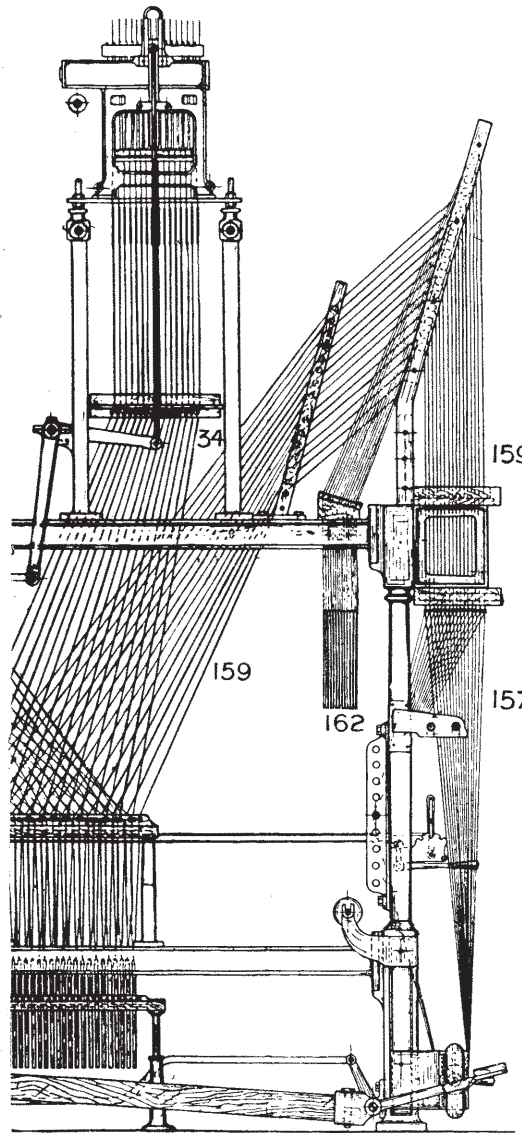

FIG. 395.

39 of the wire Z, Fig. 394. The other end 40 of wire Z is attached to a cord 41, and the wire Z is fulcrumed at Y.

It will be understood that all the cross cords, C and D, etc., in Fig. 159

The positions of the equal-weighted lingoes 37 A and 37 B affect the position of the punch needles 135, which are similar to those numbered 135 in Fig. 381.

It will be remembered that these punch needles 135 must descend a short distance under the influence of the lingoes 42, Fig. 394, when holes are required in the cards or paper, so that their >-shaped ends may appear in the path of the >-shaped knives 134 of the knife-block 90. If the cord 38 is slackened, a punch needle 135 is lowered; but if the cord 38 remains as illustrated in Fig. 394, the corresponding grid knife 134 would pass between two adjacent punch needles 135, and a blank would appear in the paper strip 138.

In Fig. 394, and in the much enlarged view of the cords and lingoes in Fig. 397, it will be seen that a comparatively large knot 163 is tied on the cord 38 and on the two short cords 166 and 167, the two latter marked only in Fig. 397. The short cord 166 passes from the knot 163 through the ring 147, and is then attached to the lingo 37 A. The short cord 167 passes direct from the knot 163 to the second lingo 37 B. Finally, the cord 38 passes, as before, to one end

are supposed to be interwoven with the vertical cords 157, Fig. 394. If, therefore, an iron rod is inserted between these vertical cords 157 so as to replace the first or upper cross cord, and then this iron rod is made, either mechanically or manually, to pull the vertical cords apart so as to make, so to speak, a shed, as partially indicated in Fig. 395, the cords 157 thus pulled out of their direct line would obviously raise the corresponding lingoos 37 A, through the medium of the cords 159. This movement, although representing all cords pulled for the figure on the first pick, would have no effect upon the knots 163, and hence no effect upon the cords 38 or the cords 41. But if the corresponding hooks in the jacquard 164 be lifted at the same time, through cords 146, then both companion lingoos 37 A and 37 B would be raised simultaneously, and the corresponding cords 38 and 41 slackened, thus lowering the punch needles 135 to be pushed to the left and through the paper 138 by the moving grid knives 134. It is not difficult to see, however, that under such circumstances the cutting on the paper 138 would coincide with the long painted floats of the design paper. On the other hand, if certain hooks in these groups in the jacquard 164 are prevented from rising, their corresponding lingoos 37 B would remain down, and hence blanks would appear at these points on the paper 138, because one lingoo 37 A is unable alone to slacken cord 38. Consequently, if the figure on the paper 138 requires to be punched so as to develop the 8-thread sateen, $\frac{2}{-1}$, it would be necessary to place a set of cards or paper cut for this weave on the cylinder of jacquard 164. Any other weave for the figure could be obtained by a suitably punched set of cards for the jacquard 164.

It is desirable to cut the weave for the ground simultaneously with the cutting of the weave for the figure, and this is effected by means of the 16-row jacquard 165, the cords 34, the knot 163, and the ring 147. The knot 163 is made large enough to prevent it from passing through the hole of the ring 147; hence if a cord 34 is raised by a hook of the jacquard 165, the ring 147, on being raised, would just slide upwards a short distance on the cord 166, Fig. 397, and then raise cord 38 by coming into contact with the knot 163. The lingoos 37 A for the ground part have, of course, not been affected by the lifting of the lingoos 37 A for the figure part, and hence the cords 166 belonging to these low-positioned lingoos 37 A would be taut; but both lingoos 37 A and 37 B would be raised by means of the ring 147 and the knot 163, and consequently the corresponding cords 38 and 41 would be slackened to enable a hole to be punched for the ground. If cards for the ground weave, say $\frac{1}{-4}$, be placed in the cylinder of the jacquard 165, this weave would be punched on the ground parts of the paper 138 simultaneously with the punching of the $\frac{2}{-1}$ sateen weave for the figure.

Any two weaves, one for the figure and one for the ground, can be punched at the same time on the thin paper 138 ; the making of the point-paper design would be of the simplest possible nature ; while the selection of the marks for the insertion of the cross cords or picks in the simple would also be easily performed.

Although, say, every fifth cord 34 (Fig. 394) is raised by the jacquard 165, it does not follow that all such cords are capable of lifting the corresponding knots 163 and lingoes 37 B, for some of the latter may be required down for the figure binding. For those cords that are required down, the lingoes 37 B would be in the low position, but the companion lingoes 37 A would, of course, be up, because of the pulling of the cords 156 ; hence the cords 166, Fig. 397, belonging to this group would be slack, and the effect of lifting the rings 147 by means of the cords 34 would simply cause the rings to slide on, and take up, the slack cords 166.

Another arrangement of the bottom cords and lingoes is illustrated in Fig. 398. In this case, each punch needle 135, Fig. 394, is connected, through the necessary cords, to three weights, 37 A, 37 B, and 37 C, Fig. 398, the weight 37 A being about twice as heavy as either weight 37 B or weight 37 C.

The heavy weights 37 A are lifted by the cords 159, Figs. 394 and 395, when the cords 157 of the simple are deflected by the operative ; and

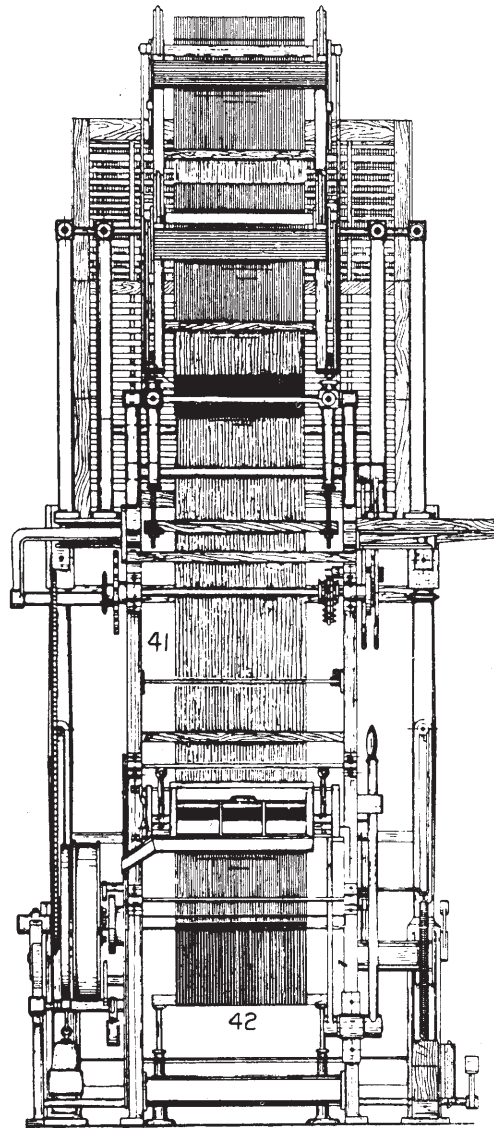

FIG. 396.

when the lighter weights 37 B are lifted by the cords 146 from the jacquard 164, the needle punches 135, Fig. 394, are lowered by the cords 41.

In Fig. 398, mails 163 replace the knots 163 and rings 147 in Figs. 394 and 397. The weight 37 A is connected to the cords 157 of the simple by the cords 159, and a shorter cord 167 passes from the weight 37 A, over the glass rod 169, and then to the light weight 37 B. A third cord 168 passes from the weight 37 A through the mail 163 and to the third weight 37 C. The weights 37 B are connected directly by cords 146 to

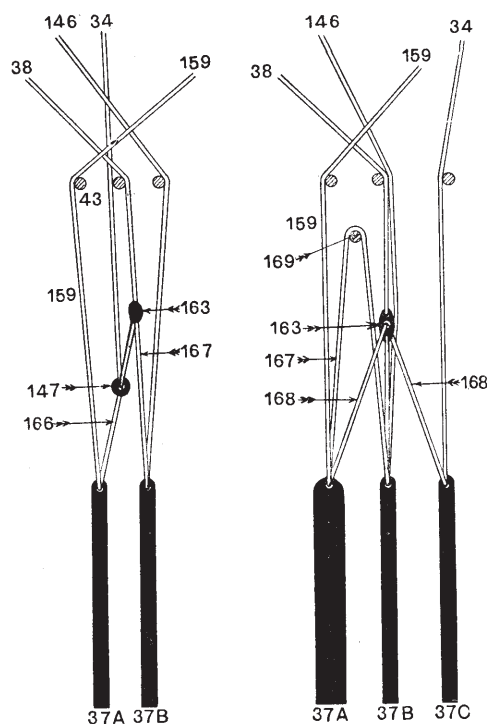

FIG. 397.

FIG. 398.

the hooks of the jacquard 164 for the figure, and the weights 37 B are also connected through the mails 163 and the cords 38 to the needle punches 135, Fig. 394. Finally, the third weights 37 C are connected directly to the hooks of the jacquard 165 by means of cords 34.

When the simple cords 157, Figs. 394 and 395, are pulled, the cords 159 and the heavy lingoes 37 A, Fig. 398, are lifted. The upward movement of a lingoe 37 A causes a slackening of cords 167 and 168 without affecting the corresponding needle punch 135, Fig. 394, as this is held in the inoperative position by the weight 37 B. Hence, to obtain the necessary weave in the figure portion, it is essential to lift simultaneously the

cords 159 and all the cords 146 and lingoes 37 B which are not required to be down for the figure weave. The remaining needle punches are for the ground, and are left in their normal positions because the corresponding heavy weights 37 A are not disturbed by unpulled cords 159.

In order to cut the ground weave in the parts corresponding to the unpainted portions of the point-paper design, the cylinder of the jacquard 165 is provided with a set of cards, say, 1 up and 4 down, or any other order, and hence the hooks of the jacquard 165 would lift every fifth cord 34 and every fifth weight 37 C. The lifting alone of these cords 34

and weights 37 C does not affect the needle punches 135, but when this lifting action takes place, the corresponding short cords 168 are slackened, and the heavy weights 37 A draw up the slack and simultaneously draw

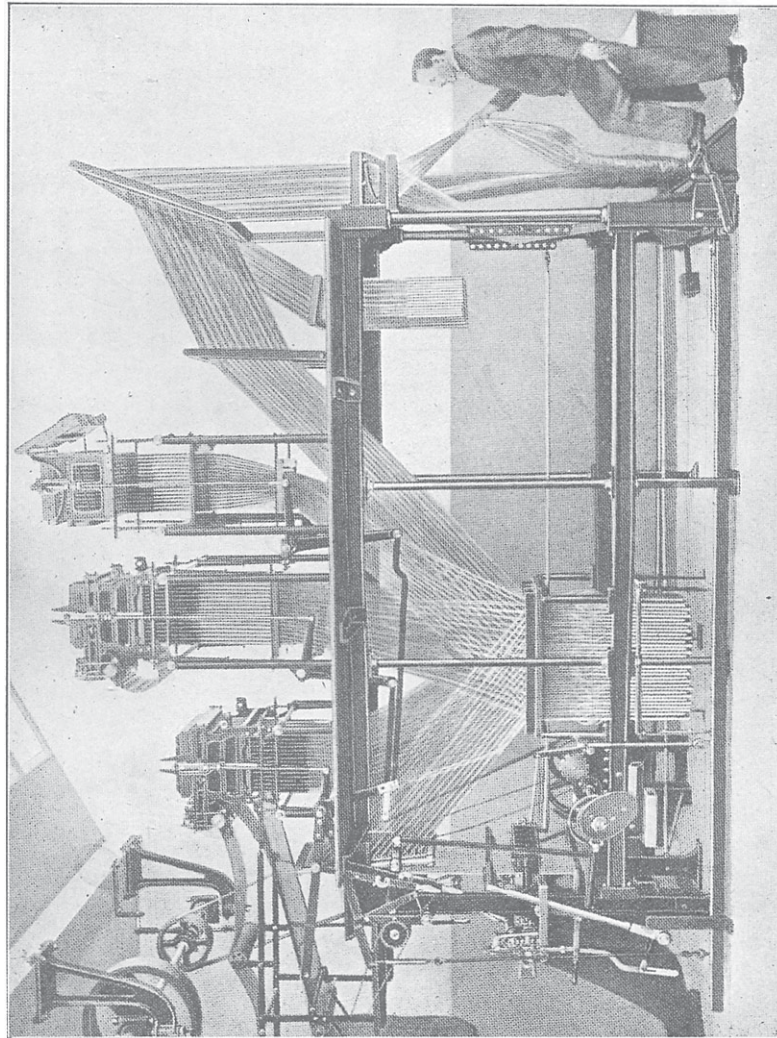

FIG. 399.

up the lighter weights 37 B. Hence, cords 38 are slackened, and these allow the needle punches 135, Fig. 394, to fall into the path of the moving grid knives 134 to effect the cutting of the holes for the ground weave.

Fig. 399 illustrates the operative at work. He is at present holding

out a certain number of simple cords—corresponding to the painted portions on one horizontal line or pick of the point-paper design—for the first pick. All the other cross cords, interwoven with the vertical cords of the simple, are shown in a body nearer the floor. The foot treadle actuates, by levers and rods, the lifting and punching mechanism (see also Fig. 395); after the paper has been punched by the mechanism on the left for one pick, the mechanism is disengaged automatically so that the attendant may pull the next cross cord for the second pick, and so on. Two or more simples may be provided, in order that one or more may be in preparation while others are in use at the machines. If actual

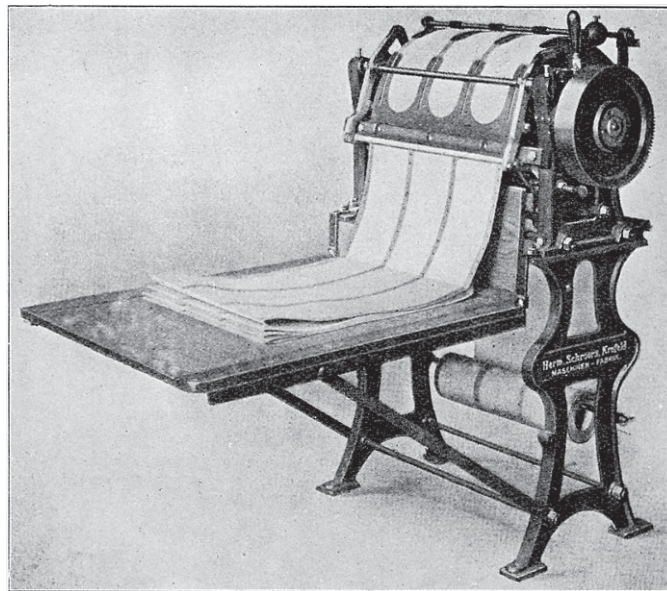

FIG. 400

repeating is to be performed, the pilot paper strip is placed on the left of Fig. 399, and the hooks of this machine operate the needle punches as before.

After the long paper strip has been punched, it is usually supported on a light card cradle by means of small projections on light metal clips, a doubled part of which grips the paper. In order that the paper may be prepared correctly for the machines, especially when long lengths are used, it may be creased by a machine as indicated in Fig. 400 before it is taken to the card-cutting or repeating machine.

A somewhat similar method of reading-in is employed in connection with the cutting of pasteboard cards on the Vincenzi pitch. Fig. 401

illustrates one type of machine for the purpose, and it will be seen that there are two simples connected by suitable cords to the repeater or puncher on the right. We have seen cards (strawboard cards) cut with this pitch on a piano card-cutting machine, and then the loom cards repeated from the common strawboard cards on the repeater on the right.

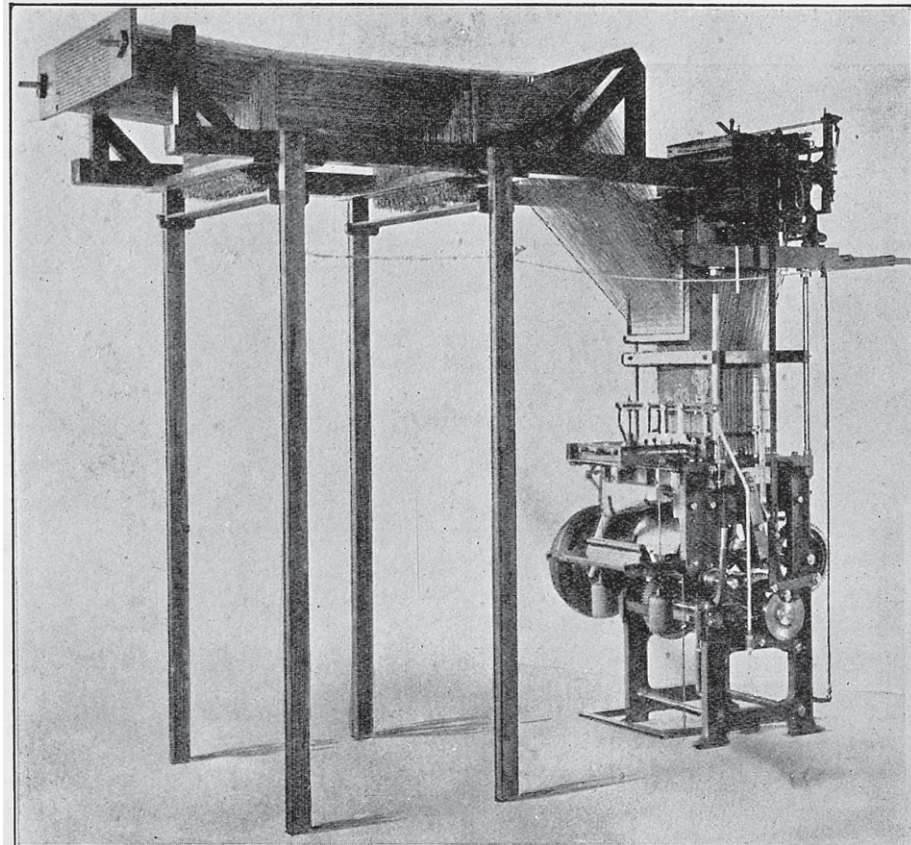

FIG. 401.

The usual French machine for the Vincenzi pitch is shown in Fig. 402, and, so far as the general arrangement of the cords is concerned from the jacquards and simple, is very similar to the machine illustrated in Figs. 394 and 395. The simple is omitted in Fig. 402, but its position is on the extreme right. This machine is usually arranged for 1320 needles, and requires two operatives. One operative draws the cords of the simple on the right, and, as already described, while the other operative performs

the actual punching operations on the left. The actual cutting apparatus differs, however, from that illustrated in Figs. 394 and 395, although it

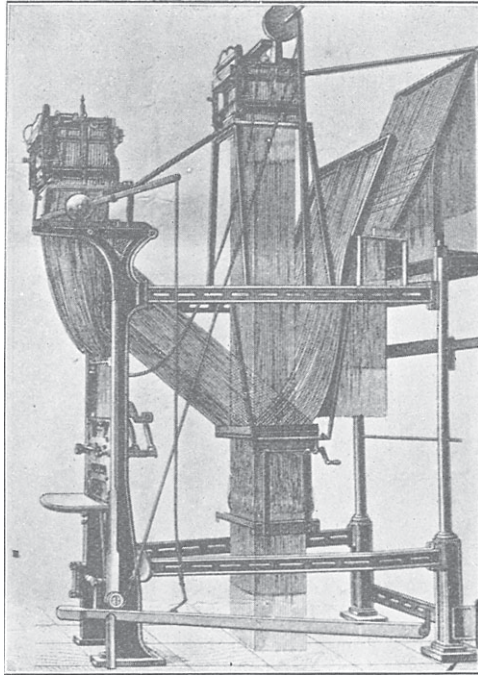

FIG. 402.

is very similar to, but finer than, the punching parts illustrated in Figs. 302 to 305 in connection with the Devoge repeater.

ADVERTISEMENTS

**PATENTEES, DESIGNERS,
AND BUILDERS
OF THE
MOST IMPROVED
MACHINERY
FOR
CUTTING JACQUARD CARDS**

See Figs. 160 to 167, and pages 197 to 206.

**PRODUCTION DOUBLED
OPERATING COSTS HALVED**

**WILLIAM BENSON, Limited.
ROBIN HOOD WORKS,
NOTTINGHAM, ENGLAND.**

ESTABLISHED 1855.

Telegrams:
"Wilben, Nottingham."

Telephone:
1736.

Codes:
Bentley's, Liebers, A.B.C.

INDEX

- Accessories, 144
 Accuracy of holes in cutting plates, 99
 Adjustment of card guides, 113, 114
 All-over repeating tie. *See* Repeating ties
 All-single tie. *See* Straight-through tie
 Alteration in sketch, 59, 60, 79, 84, 85
 Arrangement of jacquards on looms, 51, 52, 53
 Automatic (American) lock-stitch lacing machine, 322
 peg- and lace-hole machine combined with lacing machine, 323
 Automatic (Benson's) card-cutting machine, 197-203
 Automatic peg- and lace-hole machine, 313, 322, 325
 Automatic peg- and lace-hole machine combined with lacing machine (Hardaker's), 313
 description of, 314-321
 Bessbrook jacquards. *See* Twilling jacquards
 Bordered designs, 53
 British (ordinary) pitch jacquards, 51
 British pitch of card and jacquard, 114
 Brussels carpet, 54, 121, 123, 127, 129, 130
 Brussels carpet card-cutting machine, description of, 120-132
 Brussels carpet designs, 130
 Brussels carpet jacquard, capacity of, 130
 Brussels carpet loom, 55, 130, 132, 244, 259, 267, 325
 Card-cutting (cord) machine, 118, 119
 Card-cutting, definition of, 96
 for cast-out harnesses, 25
 for Lever's lace machine, 192, 193
 for the lace trade, 182, 185
 instructions for, 225, 227, 229, 230, 231, 233
 lacing and wiring department, 157, 158, 159
 Card-cutting machines, 96-180
 Card-cutting machines (*contd.*)—
 machines for the lace trade (Benson's automatic), 197-203
 do. (Benson's non-automatic), 197, 198
 do. for Brussels and Wilton carpets, 120
 rate or speed of, 137, 184, 185, 186, 203
 Card cylinders, hammers for, 160
 Card guides and adjustment of same, 113, 114, 249, 250
 Cards affected by climate, 145, 146
 Cards and card lacing, desirable conditions for, 292
 Cards at back of loom, 4, 15, 18, 68, 219, 221, 223, 227, 229, 230
 Cards at end of loom, 223, 224
 Cards at front of loom, 4, 15, 18, 67, 220-223, 227, 229, 230
 Cards, comparing the value of, 146
 cost of, 67, 72, 90, 145, 146, 148
 cut and weave inserted without piano machine, 415-421
 dimensions of, 96, 136, 152, 176, 203, 356
 laced backwards, 221, 222, 226, 227, 228, 230, 231
 laced forwards, 221, 228, 230
 large numbers of, 11, 12, 66, 67
 method of cutting, 107, 108, 110, 111, 137, 139-142, 177-181, 219
 numbered end of, 218, 306
 of different sizes and pitches, 134, 135, 138, 356
 order of cutting, 98, 220
 pilot set for repeating machine, 232, 329, 387-390, 402, 403, 404, 407, 411, 413, 422
 pitches of, 136, 137
 semicircular holes in edges of, 116, 293
 sliding on lacing twines, 214, 293, 294
 truck for, 323
 working forwards and backwards, 60, 61, 226
 Casting-out or fileying, 19, 22-26, 30

- Centre-ties, 7, 37-40, 43, 44, 53, 54, 63, 72, 90, 94, 226
 advantage of, 37
 defective part in, 40
- Clearing plates, 302, 307, 308, 311, 312, 317, 335, 336, 341, 342
- Cloths for table decoration, 80
 woven face downwards, 222, 231
 upwards, 220, 225, 227, 231
- Comberboards for extra warp fabrics, 35, 36, 37
 relative positions of jacquards to, 5, 6, 8, 223, 224
 sectional strip, 15, 18
 solid, 15, 18
- Common harness jacquard. *See* Twilling jacquard
- Compound ties. *See* Mixed ties
- Cords (reference to design, point or draught paper), 66
- Cramming of harness reed, 87
- Creasing paper for fine-pitch machines, 422
- Cutting cards on Brussels and Wilton carpet machine, 123-132
 holes in cards for selvages and similar work, 212
 plate (hand), 96
 two cards simultaneously, 121, 132, 143, 185
- Cylinders coupled to work as one, 36, 48, 120
- Damaged cards, 145, 292, 293
- Design, cost incurred in making a, 146, 147, 149
- Design paper, 25, 26, 35, 36, 40, 45, 48, 58, 59, 60, 66, 87, 90, 98, 100, 106, 122, 123, 126, 130, 132, 136, 147, 148, 155, 167, 174, 199, 206, 222, 225, 229, 406
 difficulty of cutting from two sheets of, 182
 in two portions, 182
 position of, on reading board, 98, 219, 226
 re-ruling, 48
 significance of painted parts on, 98, 111, 222, 225, 227, 229
 unequally ruled, 59
- Dobbies and dobby shedding, 1, 8, 30, 98
- Double tie, 44, 46, 48, 49, 50, 57, 65, 66, 77, 80, 89
- Draw-boy jacquard, cords in, 195
- Duplicating cards. *See* Repeating
- Electrical card-cutting, 193, 194, 414
- Electrically driven looms, 15
- English type of jacquard, 8
- Equipment of card-cutting department, 294, 295
- Experimental weaving, sizes of jacquards for, 20
- Extra warp figuring, 33, 34, 35, 36
- Fileying. *See* Casting-out
- Fine-pitch jacquards, 42
- First harness cord, needle, hook and thread, 8, 15, 18, 38, 123, 218, 219, 220, 221, 222, 223, 225, 227, 234
- Float, length of, 71, 83, 84, 85
- Griffe, times of movement of, 343
- Hand punches for inserting holes missed during the operation of cutting, 144, 145
- Hand-punching plates, 96, 97, 120
 method of putting cards on, 98
 punches for, 98, 99
- Harness and shaft combination, 30, 31, 33, 35
 cords, 7, 8, 12, 13, 28, 51, 53, 202
 angle of, 51, 52
 friction amongst, 18
 mounting, 6, 7, 18, 21, 36, 40, 46, 48, 53, 64, 72
 order of drawing the threads in, 3, 4, 8, 47
 reed. *See* Comberboard
 tie for maximum and minimum widths of cloth, 49
 ties, 6, 7, 8, 10, 12, 13, 26, 28, 47, 49, 50, 57, 90, 202
 ties for striped designs, 26, 33
 numerical, 27, 32, 48, 50, 65, 73, 74, 75, 77, 82, 85, 89, 110
- Heck, 9
- Imperfect lacing of cards, 207
- Individual cloths, 61
- Inferior cards, 145
- Jacquard working negatively and positively, 411
- Jacquards, arrangement of parts in, 4
 arrangement on looms, 51, 52, 53, 67
 bottom needle in, 3
 English type of, 8
 fine-pitch, 42
 first row of needles and hooks in, 7, 98
 needles per row in, 1, 2, 38, 47, 48, 49
 number of, required for four distinct methods of weaving a given design, 67
 relative positions of comberboards and, 5, 6, 8
 Scottish type of, 13
 sizes of, 1, 12, 20, 26, 27, 31, 33, 35, 36, 38, 40, 47, 50, 51, 64, 77, 88, 91, 97
 top needle in, 3
 Twilling. *See* Twilling jacquards

- Joining of weaves and designs, 71, 72, 75, 78, 79, 83, 84, 88
- Knots, detection of, on lacing twine, 271
on lacing twine, 208, 216, 255
- Lace curtain, 53, 195
trade, 192
- Lace trade, 185, 191, 196, 197
- Lacing, 147, 148, 150, 181, 203, 207, 293
- Lacing and peg-hole machines combined
(American), 323
speed of, 324
(Parkinson's or Hardaker's), automatic, 313
- Lacing and wiring frames, 209, 210, 211, 217, 220
methods of placing cards on, 211
methods of spacing cards on, 209, 210
- Lacing cards by hand, 207, 208, 213, 214, 215, 216
by machine, 207, 235-276
description of, 213, 214
- Lacing cards mechanically, 235-276
reasons for, 213
with two needles, 215
- Lacing holes, 97, 98, 108, 123, 126, 129, 210, 245, 293, 296, 299, 310
- Lacing machine, American automatic lock-stitch, 322
American hand-feed lock-stitch, 322
American loop-stitch, 323
- Lacing machine, Parkinson's rapid (Hardaker's), 258
brake of, 260, 261, 268, 269
cams for, 258, 259, 260, 267, 268, 269, 271
chain for cards, 270, 271, 275
cop winding mechanism, 270, 271, 272, 315
description of, 261-276
lacing mechanism, 272
needles, 267, 272, 274, 276
presser foot, 272, 274
ratchet wheels, 259, 260, 261
shuttles and shuttle carriers, 267, 273, 274, 275, 276
speed of, 276
- Lacing machine, Singer's, 235
cams for, 236
description of, 236-258
feed ratchet wheel of, 242-247, 254
feed wheels of, 239, 242-247
adjustment of, 251, 252
number of pegs in, 242
method of operating, 254, 255
movements of needle of, 245, 246, 253, 254
needle and thread take-up mechanism of, 247, 248, 249, 254
presser foot, 249, 251
- Lacing machine, Singer's (*contd.*)—
shuttles for, 250, 251, 252, 253, 254, 255
speed of, 238
spool winding mechanism of, 255-258
- Lacing twine, 207, 208, 211, 213-217, 235, 239, 246, 248, 250, 252-255, 258, 269, 271, 272, 274, 275, 277, 292, 293, 295
- Lacing without holes, 117, 293
- Lashing frame, 196
- Lay-over tie. *See* Centre-ties
- Lever's lace machine, 192
- Lift-in designs, 80, 87
- Lingoes, 7, 408, 409, 410, 414
- London tie, 618, 223, 232, 234
advantage of, 18, 35, 36
- Mails or mail-eyes, 7, 26
- Mirrors, 62
- Mistakes in card-cutting, 144
- Mixed ties, 7, 27, 34, 43, 44, 46, 90
- Multi-coloured fabrics, 91
- Neckband, 7, 8, 13, 75
- Norwich tie, 6, 14, 15, 223, 232
- Numbering cards automatically and otherwise, 326, 327
- Objections to certain types of ornament, 61, 62
- Overshotted fabrics, 59, 60
- Paisley plaid, 39
- Paisley shawl, 39
- Paper, strengthening strips for, 175, 179
- Peg- and lace-hole machines, 295, 324, 325
American, 313, 322, 325
automatic, 313
Ayrton's, adjustments for cards and punches, 306
adjustments of punch plates, 310
description of, 303-309
method of working, 306-309
- Peg- and lace-hole machine and Parkinson's (Hardaker's) rapid lacing machine combined, 314
- Peg- and lace-hole machine, Devoge's, adjustments of punches and hooks, 301
description of, 296-303
method of working, 302, 303
- Peg-hole cutting machine, fine-pitch, 151
- Peg holes cut in long lengths, fine-pitch, 152
- Peg holes damaged, 177, 293
- Piano card-cutting machine (American), 143
- Piano card-cutting machine (British, coarse or ordinary pitch), 100, 202
carriage, movement of, 100, 104, 106, 107, 108, 110, 112-116

ADVERTISEMENTS

George Hattersley & Sons,
ESTABLISHED 1789 **Limited.**

KEIGHLEY

**MAKERS OF THE FIRST POWER LOOMS
FOR WORSTED INDUSTRY 1834**

Makers of every Description of

WINDING

WARPING

BEAMING

AND

WEAVING

MACHINERY

Original Inventors and Makers of the

DOBBY OR HEALD MACHINE

SPECIALITIES

Automatic Re-Shuttling Looms

Weft Winding Machinery

Telegrams—
"Hattersley, Keighley."
Telephone—
Keighley 175 and 176 (Private Exchange).

Codes—
5th Edition, A.B.C.,
Liebers, Marconi,
and Private.

ADVERTISEMENTS

WARD BROTHERS, LTD.
BLACKBURN

PATENT DOBBIES

for all purposes and widths of loom.

Dobson's Patent Drawing-in Frame
and
Patent Mechanical Reacher-in.

Telegraphic Address :
WARD, BLACKBURN, 5260.

Codes :
MARCONI, BENTLEY'S, ABC 5th.

**An Essential Invention in Jacquards
and Harnesses.**

IMPORTANT TO ALL USERS.

FRICITION and CHAFING of Harness and Neck Cords and Stitching in Weaving reduced to a minimum by another valued invention by CHAS. H. DRACUP, of the firm of SAMUEL DRACUP, which users declare greatly extends the life of Harnesses, etc.

The improvement is effected by simply reversing the bend (without cranking) at the lower part of every alternate lifting wire, and thus causing a diversion, and allowing double the space for upper part of harness, neck cords, hoops and links, and so granting perfect freedom for operation, with no enlargement of Jacquard and harness and no alteration to cards, whilst it is applicable to all types of single and double lift Jacquards.

The machine is on the market and in commercial use, and is found to be of great utility by the invention; a double lift machine with Vincenzi fine pitch is now attained and constructed as a commercial success. Further particulars may be had from

SAMUEL DRACUP

(CHAS. H. DRACUP, THORNTON DRACUP),

Lane Close Mills, GT. HORTON,

Makers and Improvers of Jacquards and Harnesses since 1825.

Telephone 1510.

Telegraphic Address : "Harness, Bradford."

The above can be inspected at the Bradford Technical College.

ADVERTISEMENTS

JACQUARD MACHINES

AND

HARNESSES

FOR

FANCY WEAVING

CARD PUNCHING MACHINES

COPYING and REPEATING MACHINES

WIRE WORK and all JACQUARD SUNDRIES

LATEST IMPROVED TWILLING JACQUARDS

FINE PITCH JACQUARDS

Catalogues and Prices on Application

JAMES M^cMURDO, LTD.

NEW STREET,

MILES PLATTING,

MANCHESTER

Telephone Number—2649 Central.

ADVERTISEMENTS

WILLIAM ALLEN & CO.
LIMITED.

JACQUARD
CARD MANUFACTURERS
FOR ALL TEXTILE TRADES

BUTCHER STREET WORKS,
NOTTINGHAM,
ENGLAND.

ESTABLISHED OVER 50 YEARS.

ATHERTON BROS. L^{TD.}
HANOVER STREET FOUNDRY, PRESTON

ESTABLISHED OVER THREE-
QUARTERS OF A CENTURY

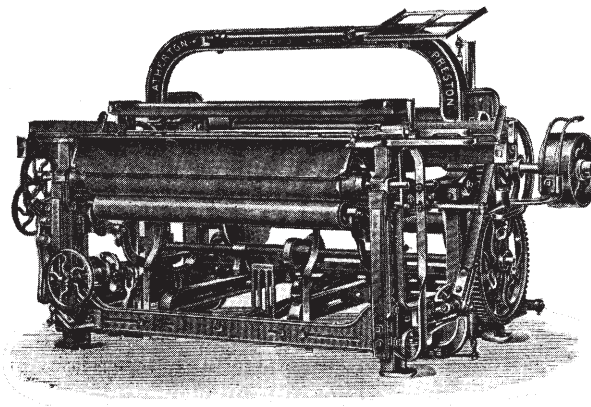

COMPLETE MILLS FURNISHED
AND EQUIPPED THROUGHOUT

MAKERS OF ALL CLASSES OF **LINEN** AND **COTTON** WEAVING
AND PREPARING MACHINERY. LOOMS UP TO 170" WIDE.
SIZING, DRESSING, WARPING : WINDING, etc.

ADVERTISEMENTS

“English Electric”
MOTOR
driving
heavy Jacquard Tapstery Loom

This is part of an installation including 75 motors at the mills of W. Ewart & Co., Belfast.
The English Electric Company have a large staff of Engineers who specialise in the application of electricity to the Textile Industry; their advice is at your disposal for any scheme you may have under consideration.

The
ENGLISH ELECTRIC
Company Limited
WORKS:—BRADFORD, COVENTRY, PRESTON, RUGBY, STAFFORD.
HEAD OFFICE:—
Queen's House, Kingsway, London, W.C.2.

ADVERTISEMENTS

**PICKERS, BUFFERS,
AND
LOOM SUNDRIES**

Fifty years' experience in the Manufacture of Loom
Sundries.

SOUND QUALITY. ATTRACTIVE PRICES.

Write for Samples and Quotation.

JAMES KERSHAW & CO. (ROCHDALE) LTD.
HEYBROOK LEATHER WORKS, ROCHDALE.

DAVID KEAY & LESLIE, LTD.

HILLBANK IRONWORKS, DUNDEE
ENGINEERS AND MILLWRIGHTS

SOLE MAKERS OF THE

LESLIE SPINNING SPINDLE

WITH FRICTION DRIVE FOR SPINNING FRAMES

AND THE

DUNDEE PATENT WATER COOLER
FOR CONDENSING ENGINES

Gearing and Shafting with Ball Bearings, if required.

Textile Machinery, Cloth Measuring Machines, etc.

Loom Forgings, Crank Shafts, forged and finished.

Telegrams: "Power, Dundee."

Telephone: 1934.

ADVERTISEMENTS

NORTHROP AUTOMATIC LOOMS

are successfully weaving all kinds of
LINEN GOODS UP TO 8 LOOMS PER WEAVER.

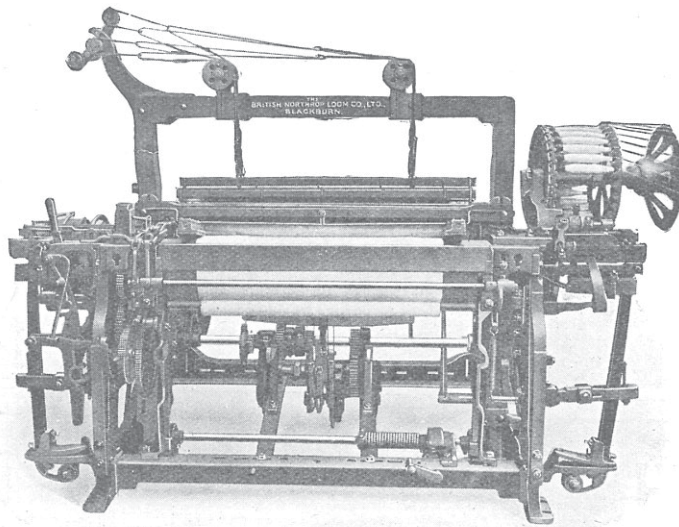

PERFECT CLOTH AND INCREASED PRODUCTION.

K model medium heavy weight in sizes up to 70'', for plain, twill Huck-a-back and DAMASK.

F model extra heavy weight in sizes up to 120'' for all above weaves in Linen.

Also Canvas and Jute.

**THE BRITISH NORTHROP LOOM CO., LTD.,
BLACKBURN.**

ADVERTISEMENTS

TELEGRAMS—"ADAMANT," GLASGOW.

TELE. No. 609, BRIDGETON.

J. M. ADAM & CO.

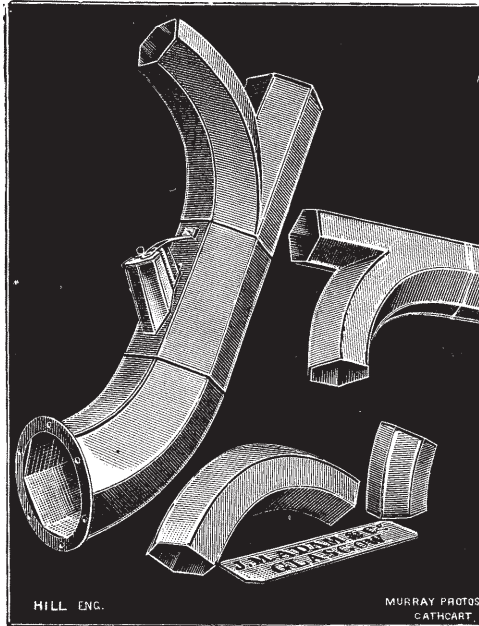

HILL ENG.

MURRAY PROTOS
CATHCART

PNEUMATIC ENGINEERS,*

**GREENFIELD IRON WORKS,
DALMARNOCK, GLASGOW.**

CONTRACTORS
AND MANUFACTURERS

OF

AIR CURRENT CONVEYERS

FOR ALL

GRANULAR, FIBROUS, OR SEMI-
PLASTIC MATERIALS.

INDUSTRIAL DUST CONTROL.

HIGH ECONOMY IN POWER OF FANS.

Efficiency of Collection and
Air Purification.

WILSON & LONGBOTTOM, Ltd.

NELSON FOUNDRY, BARNSELY, YORKS.

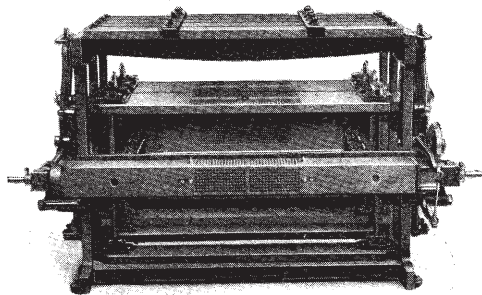

SPECIAL JACQUARDS FOR HEAVY GOODS.
MAKERS AND PATENTEES OF ALL CLASSES OF
LOOMS AND PREPARING MACHINES.

ADVERTISEMENTS

ESTABLISHED 1860.

TELEPHONE No. 47 OPENSHAW.

WADSWORTH & Co. Ltd.
PERSEVERANCE WORKS
DROYLSDEN, Nr. MANCHESTER.
Also at **THRELFALL ROAD, BLACKPOOL.**

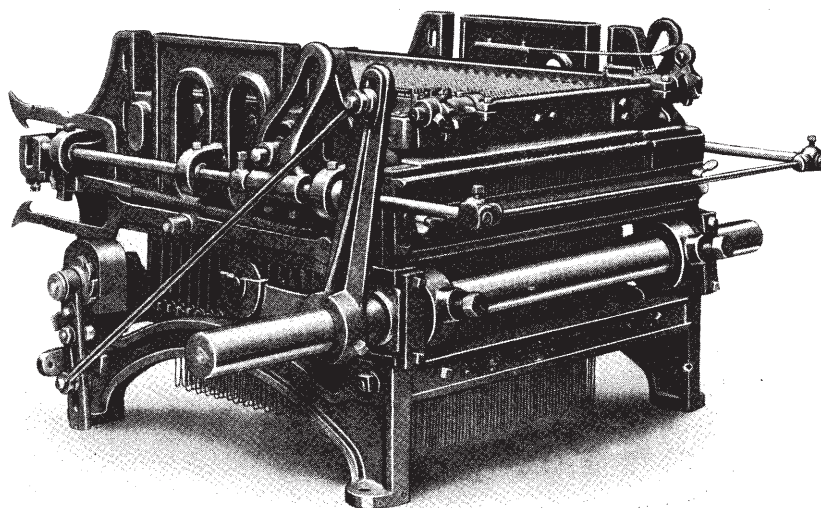

IMPROVED JACQUARD TWILLING MACHINE.

MAKERS OF
JACQUARD MACHINES OF ALL TYPES.
TWILLING MACHINES FROM 24 TO 36 ROW.
CROSS BORDER MACHINES AND
JACQUARD HARNESES.
PIANO CARD CUTTING MACHINE & PATENT
SINGLE CARD REPEATING MACHINE.
HOOKS, NEEDLES & SPRINGS, LINGOES.
COUPLINGS, DOBBY HARNESS, ETC.
PRICES & CATALOGUES ON APPLICATION.

BY THOMAS WOODHOUSE AND THOMAS MILNE.

Second Edition. Illustrated. Crown 8vo. 15s. net.

JUTE AND LINEN WEAVING

NATURE.—“This book must be ranked among the classics in technical literature. There is a thoroughness and completeness about it that appeals equally to the elementary student of weaving, to the experienced textile engineer, and to all those occupying responsible positions in the weaving departments of the textile industry. Whilst the book is written around the title and deals with the subject of jute and linen weaving, a very considerable portion is equally valuable to the cotton and other sections of the trade; in fact, it may be looked upon as a very comprehensive exposition of the subject of weaving in general, for most of the problems and mechanism connected with weaving are fully treated.”

TEXTILE MANUFACTURER.—“The book is very well written, and the diagrams are well drawn and carefully lettered to facilitate reference and make the operation of the mechanism clear to the reader. The new matter embodied in the present volume includes 108 new illustrations, with the corresponding text of the most modern machinery, and in its present form it is a highly meritorious description of jute and linen weaving mechanism. In justice to the authors we should add that the great bulk of the machinery described is used in one or all of the other three great branches of the weaving industry—namely cotton, woollen and worsted, and silk weaving—and to persons engaged in those industries the book should be equally useful.”

TEXTILE MERCURY.—“The work can be recommended unhesitatingly.”

LONDON: MACMILLAN AND CO., LTD.

ADVERTISEMENTS

Jacquard Card Machines

For ACCURACY
ECONOMY
EFFICIENCY
LONG-TERM SERVICE

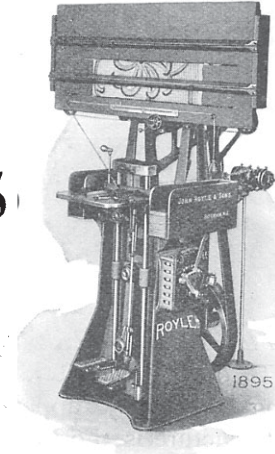

Power Piano Machine (Motor Drive).

Use **ROYLE LOCK-STITCH LACERS**—hand or automatic stack feed.

PIANO MACHINES—foot power or power.

AUTOMATIC REPEATERS—hand or power.

Machines arranged for French, Fine or any other Scale required.

Detailed information submitted on request.

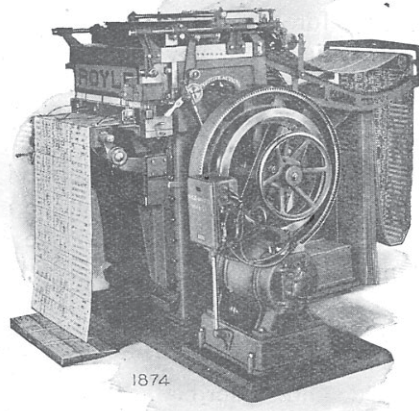

Automatic Repeater (Motor Drive).

John Royle & Sons,
Paterson, -New Jersey,
U.S.A.

See our machines as under—

Fig. 118 119 120 172 295 297 298-299 301 342 343
Page 143 144 145 212 321 322 323 326 363 364

BY THOMAS WOODHOUSE AND THOMAS MILNE.

Illustrated. Crown 8vo. 12s. 6d. net.

TEXTILE DESIGN

PURE AND APPLIED

TEXTILE MERCURY.—"This volume is an important addition to our textile literature, no book of so comprehensive a nature having previously appeared on the subject. . . . The subject of cloth structure is thoroughly dealt with, no important fabric has been neglected, and no section seems to have received more than its rational share. A feature of the book is the careful and methodical manner in which the matter has been arranged; and in previous works by the joint authors the same characteristic has been evident. They appear to have the knack of terse description, which is helped greatly by carefully prepared groupings and diagrams: no words are wasted, yet nothing essential is neglected. . . . All the structures are very well described, and the sections are perfect, giving in every case a clear idea of the fabric. The treatise is one which should be in the hands of students and manufacturers concerned with woven design, and the authors deserve the thanks of the trade for the labour and care—it must have been a labour of love—with which they have prepared the matter for so useful a book."

TEXTILE MANUFACTURER.—"The work should be of great value to all who are concerned in the designing of textile fabrics. . . . The book is of such general excellence that we confidently recommend it to our readers as a valuable contribution to the increasingly important subject of design as applied to textile fabrics."

TEXTILE RECORDER.—"The present work is undoubtedly excellent in construction, and in it the weave of almost every type of textile fabric will be found illustrated and described. We do not know another book that treats the subject so completely, and are certain that it will be welcomed by students and practical men alike."

LONDON: MACMILLAN AND CO., LTD.

ADVERTISEMENTS

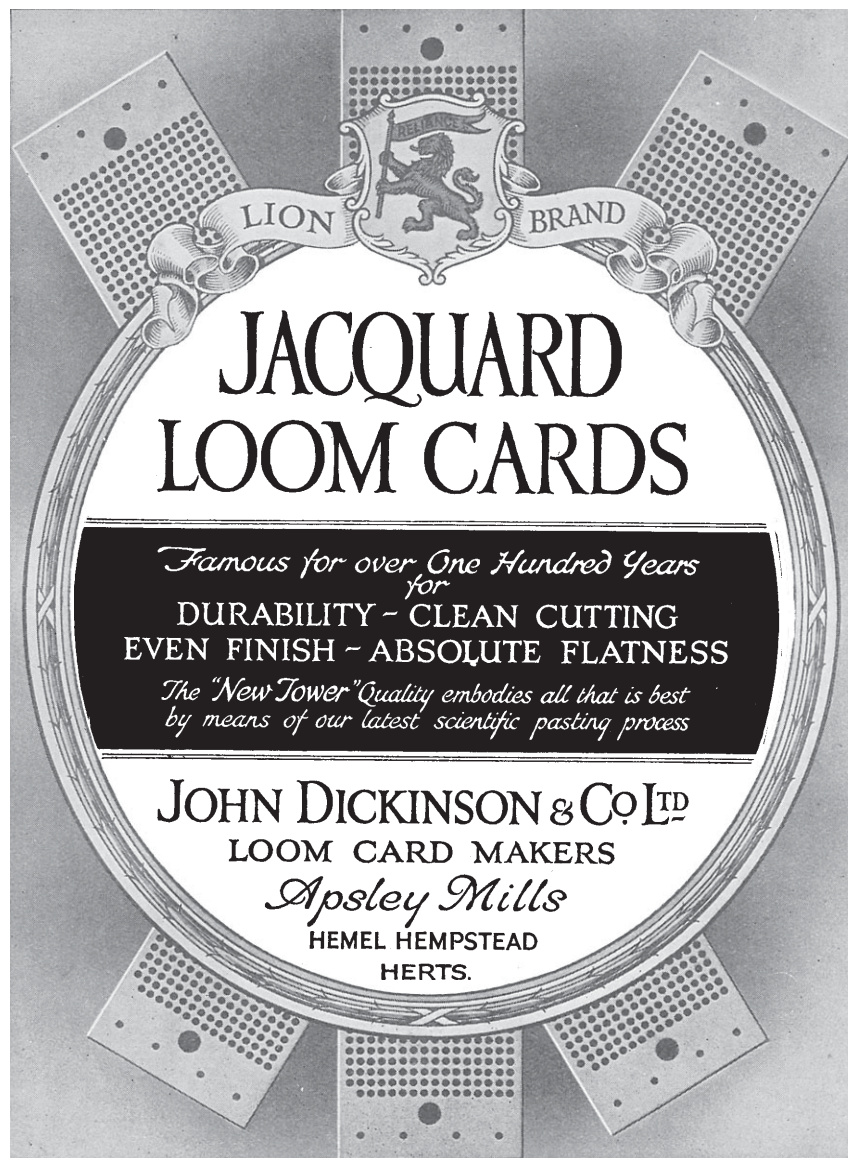

LION BRAND

JACQUARD LOOM CARDS

*Famous for over One Hundred Years
for*
DURABILITY - CLEAN CUTTING
EVEN FINISH - ABSOLUTE FLATNESS

*The "New Tower" Quality embodies all that is best
by means of our latest scientific pasting process*

JOHN DICKINSON & CO. LTD
LOOM CARD MAKERS
Apsley Mills
HEMEL HEMPSTEAD
HERTS.

ADVERTISEMENTS

Telegraphic Address:
"Engineers, Dundee."

"A.B.C." (5th Edition), Bentley,
and Marconi Codes.

**URQUHART LINDSAY
& ROBERTSON ORCHAR, Ltd.,**
Blackness and Wallace Foundries,
DUNDEE.

ASSOCIATED WITH
FAIRBAIRN LAWSON COMBE BARBOUR, Ltd.,
LEEDS.

LARGEST MAKERS IN THE WORLD

OF

Softening, Winding, Weaving, and Finishing Machinery

FOR ALL CLASSES OF

Linen, Hemp, Tow, and Jute Fabrics.

JUTE OPENERS.	COP WINDERS.	MEASURING MACHINES.
JUTE SOFTENERS.	DRESSING MACHINES.	CRISPING MACHINES.
YARN SQUEEZERS.	POWER LOOMS.	LAPPING MACHINES.
YARN SOFTENERS.	SACK SEWING MACHINES.	CLOTH STARCHING
SACK CUTTING MACHINES.	HYDRAULIC PRESSES AND	MACHINES.
CROPPING MACHINES.	PUMPS.	WATERPROOFING MACHINES.
ROLL WINDERS.	CLOTH DAMPING MACHINES.	

Special Looms for Canvas and Linoleum Cloths.

Calenders and Hydraulic Mangles.

Extensively used and recognised as the Standard Machines for the Finishing
of Jute and Linen Fabrics.

Patent Overhead Hand-Stitch Sack Sewing Machines.

Patent Power Sack Cutting Machines.

Complete Plans and Estimates supplied for Mills and Factories,
including Buildings, Shafting, and Machinery.

OUR MANY YEARS' EXPERIENCE IS AT YOUR SERVICE.

ADVERTISEMENTS

HACKING & Co. LTD.
CALIFORNIA IRON WORKS,
BURY, LANCS.

PICK
AND
PICK
LOOMS

Up to 6 Shuttles
each side.

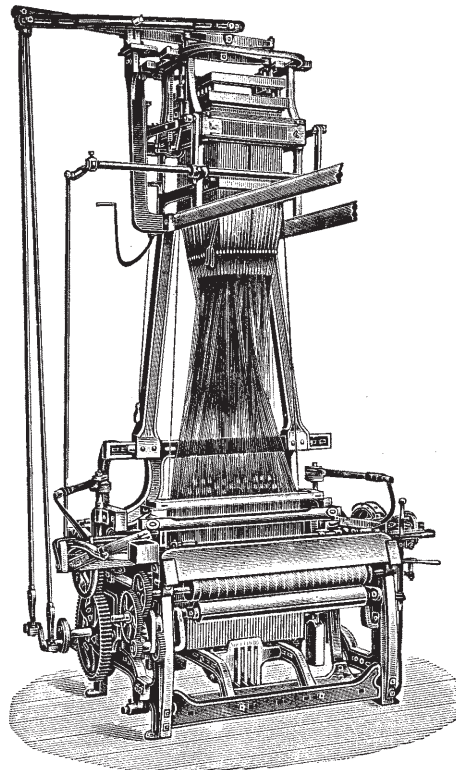

JACQUARD LOOM,

For weaving Figured Cotton, Linen, Woollen,
Union, or other Goods.

Makers of LOOMS (plain and fancy) and PREPARATORY
MACHINERY for COTTON, LINEN, SILK, WOOL,
JUTE, etc., also WAREHOUSE MACHINERY.

Telegrams: "HACKING, BURY."
Telephone: "BURY 436."

A.B.C. Code, 5th and 6th Editions.
Manchester, Royal Exchange,
Tuesdays and Fridays.