

always given in where a crossed shed is made. The easing harness lingoes require to be very heavy, about 8 to the pound being the usual size, as compared with about 25 to the pound of the douping and figuring harness lingoes.

Construction of Gauze Ground Weaves.—Typical examples of gauze ground weaves, as produced in bottom douping, 2-crossing-2, are represented at A, B, C, D, and E in Fig. 295. In the corresponding plans given alongside, the figuring

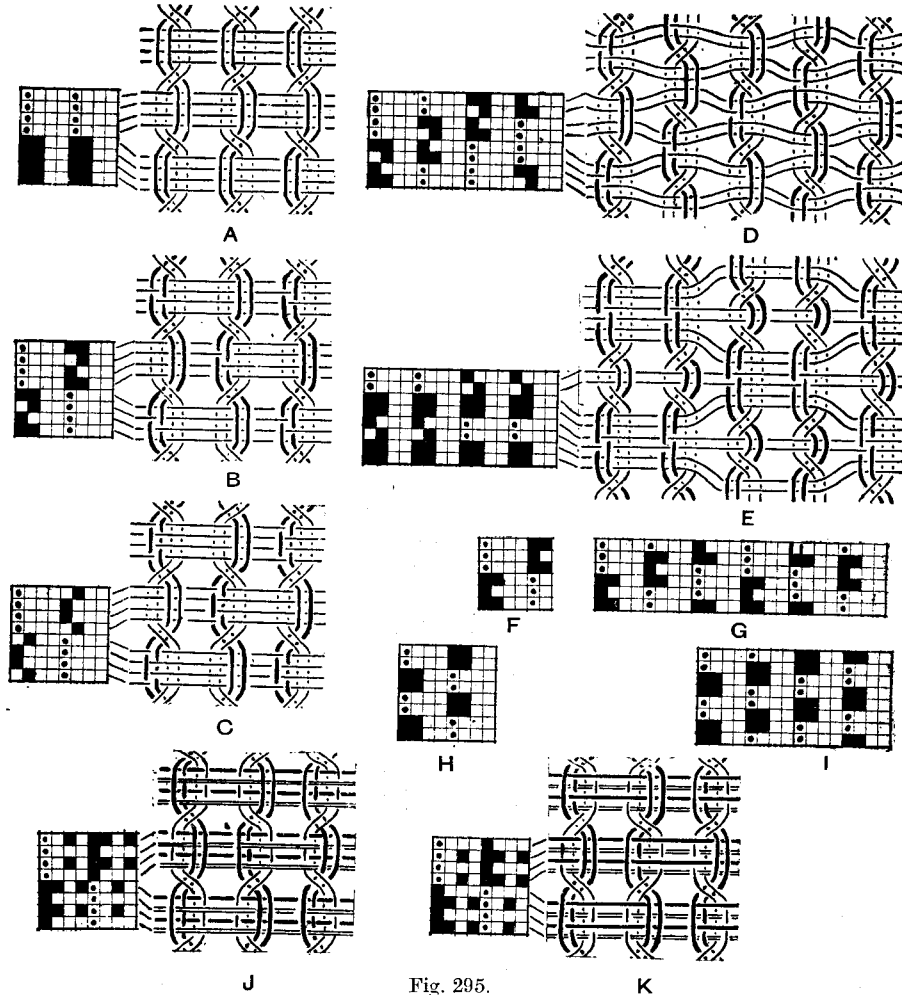

Fig. 295.

harness lifts are indicated by the full squares, and the douping harness lifts by the dots. The crossing ends, which are shown in thicker lines in the drawings, are raised by the figuring harness on the left of the standard ends, and by the douping harness on the right. When raised by the douping harness the crossing ends must be lifted in pairs; in the drawing A these ends are also shown raised in pairs by the figuring harness. If this order of lifting is continued for a considerable space

the crossing ends (which are passed in pairs through the doup mails) tend to roll round each other, and it is then difficult to form a clear shed in the ordinary weave portions of the cloth where the ends require to be raised separately. For this reason it is better to operate the crossing ends individually on one or more of the figuring harness sheds, which may be accomplished in the manner shown at B and C in Fig. 295. Another point to note is that in forming the gauze shown at

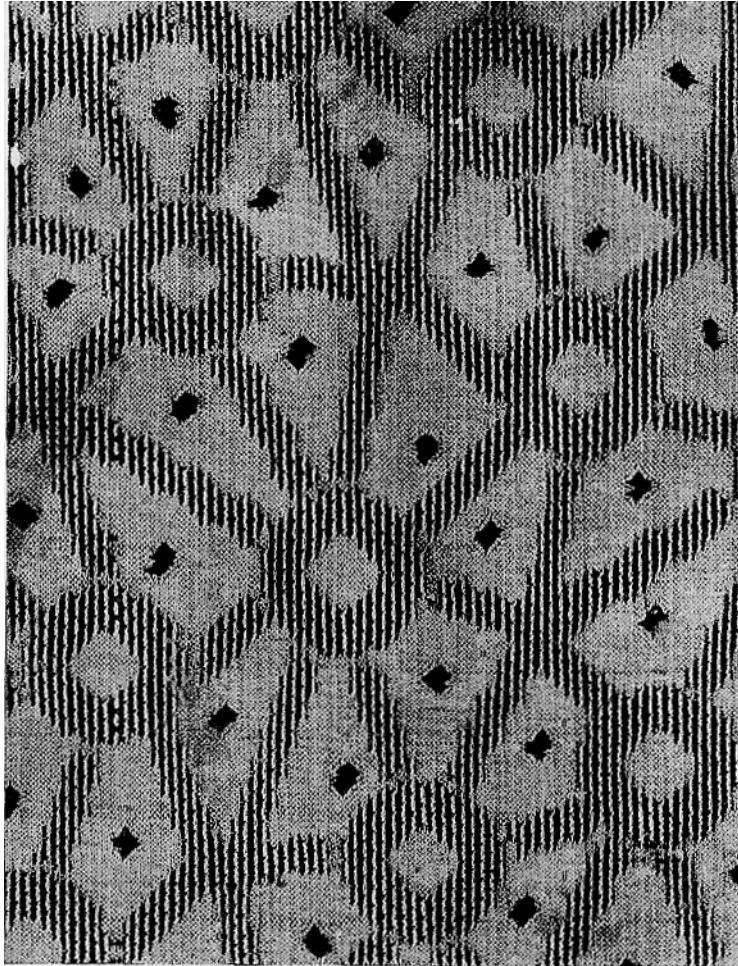

Fig. 296.

A the sheds are either all crossed or all open, whereas in B and C one half the sheds are crossed and the other half open, the strain on the warp and the harness being better distributed in the latter. D and E illustrate different methods of varying the gauze structure by distorting the picks, while the plans F, G, H, and I show other useful examples of gauze weaves. With the plan F the picks

are grouped in threes, and with H in pairs ; G and I produce modifications of these in which the picks are distorted.

The examples J and K in Fig. 295, and the corresponding plans alongside,

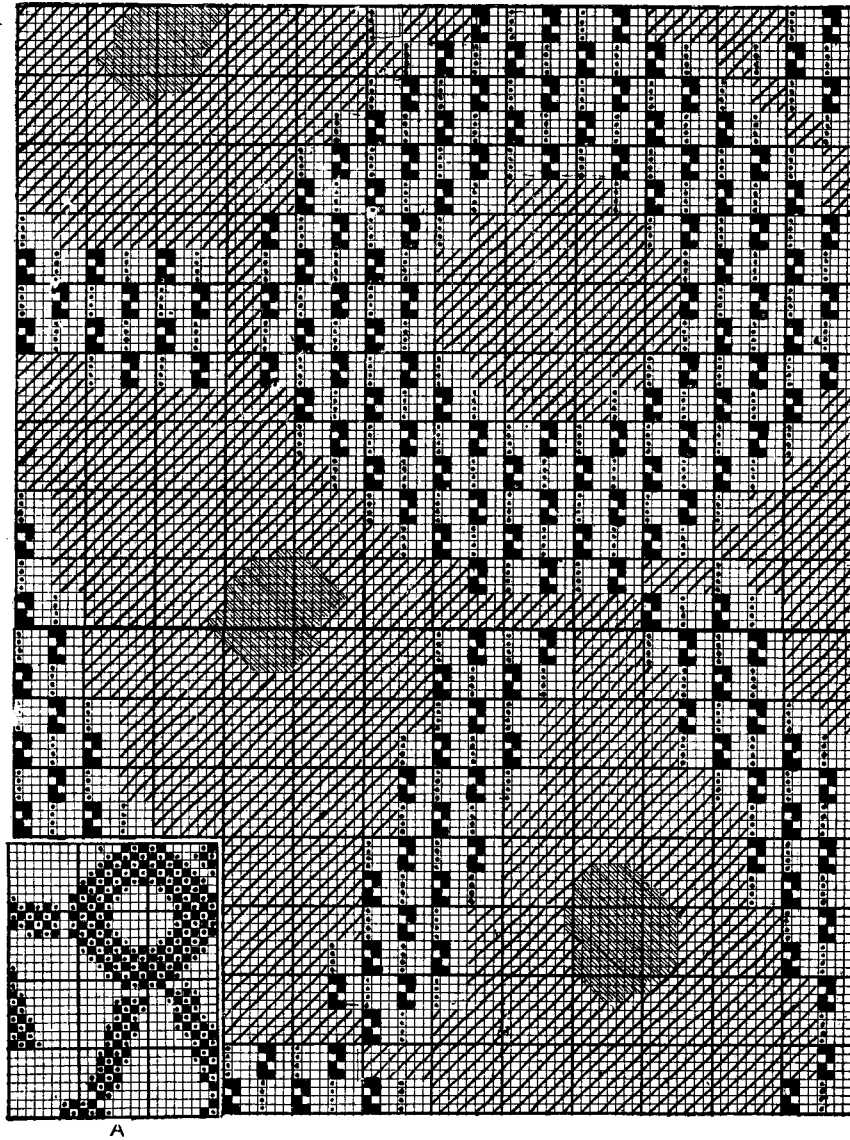

Fig. 297.

show how the gauze structure may be modified to suit a pick-and-pick order of weaving. The crossing and standard ends are interwoven in such a manner that in J the odd picks are shown prominently on the surface, and in K the even picks.

The two effects may be combined in the same design and be used in conjunction with a figure woven in two colours of weft.

Designing of Figures.—In the ordinary weave sections of a cloth, either warp or weft or both warp and weft figure may be formed, but in order that the ends will spread it is customary to surround the floats with plain or other firm weave. An illustration of a cloth, in which a figure in gauze is formed on plain ground with weft spots on the latter, is given in Fig. 296, while Fig. 297 shows a portion of the design indicated on design paper. In order that the design may be more readily followed, a reduced plan of the gauze figure is inset at A, each small square in which represents four ends and four picks of the enlarged design, the full squares indicating the open gauze sheds, and the dots the crossed sheds.

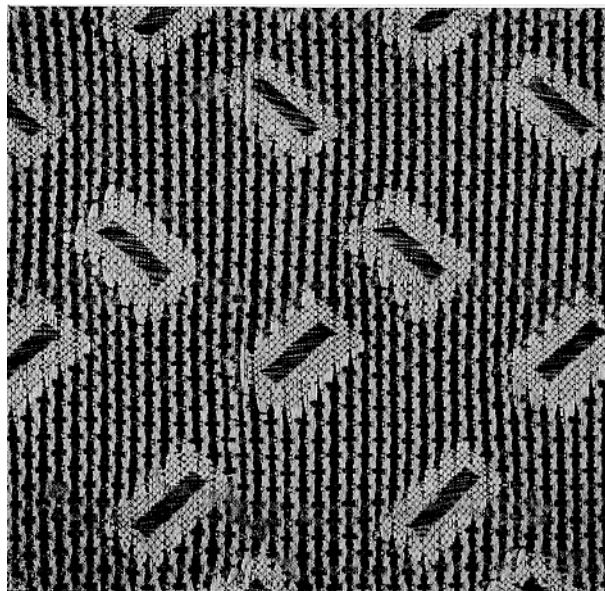

Fig. 298.

The gauze interlacing is similar to that shown at B in Fig. 295, and in the enlarged design the full squares show where the crossing ends are raised by the figuring harness on the open gauze sheds, and the dots where the same threads are raised by the doup harness. The plain weave is represented by diagonal strokes, in order that it will show in contrast with the marking of the gauze, while the weft figure is indicated by the shaded squares. The edge of the gauze figure is in steps of four-by-four, in order that it will fit with the four-by-four grouping of the warp and weft threads. This is quite right when, as in the example, the gauze forms the figure, but in the case of the gauze forming the ground the steppiness, where the gauze and the ordinary weave join, should be reduced as much as possible. In the two-crossing-two arrangement the ordinary weave must step four ends at each place, but in the weft the gauze weave may be modified at the junctions, so as to make the outline of the figure more regular.

Fig. 298 shows an effect in which a weft figure, surrounded by plain weave, is formed on a gauze ground, the interlacing in which is similar to the style represented at C in Fig. 295. In drafting a design the figure and plain weave may be painted in in the ordinary manner, and either warp or weft may be indicated. Both methods are illustrated in Fig. 299, which shows a sectional plan of the design given in Fig. 298, as produced in bottom douping. If the warp is painted, as shown at B, a weft figure may be indicated by leaving the squares blank, or be represented by a different colour to that used for the warp lifts. In the latter case the plain weave is inserted right against the figure, as shown in B, and also in Fig. 297. In the gauze ground the lifts of the crossing ends by the figuring harness are indicated on the first and second of each group of four ends, as shown by the full squares

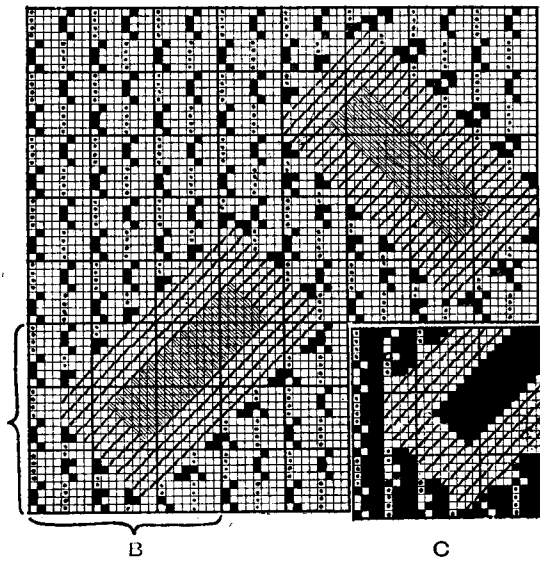

Fig. 299.

in B, while the doup harness lifts are indicated in a different colour on the first of each group, as shown by the dots. Where the gauze and plain weave join it is necessary to consider the ends in groups of four, as it is impossible to have, say, two ends working plain and two ends forming gauze. It is necessary, also, to keep in mind that the gauze and the ordinary weave are clearly separated from each other only where a doup harness lift (a crossed shed) precedes or follows the ordinary weave. It is a good system to insert doup harness lifts along the outline as near to the ordinary weave as possible where the corresponding stan-

dard ends are left down; the ordinary weave and the gauze may then be modified to fit with these lifts.

If the weft is painted, as indicated at C in Fig. 299 (this plan corresponds with the bracketed portion of B), the standard ends are all marked down in the gauze ground, and marks are inserted where the crossing ends are left down by the figuring harness. The doup harness lifts are indicated in the same manner as in painting for warp, and except for these lifts C is exactly the opposite of B. A comparison of B and C will show that in bottom douping painting for warp is more convenient than painting for weft, because fewer marks are required in the former method, and to the designer who is accustomed to other forms of gauze designing, the lifts are more readily reasoned out.

System of Card-cutting.—It has been previously noted that in each row of the machine there are 10 needles and 8 ends; in the card-cutting, therefore, a 10-rowed card has to be cut from a design which is ruled in eights. With the system of designing, shown in Figs. 297 and 299, this presents no difficulty, as the ordinary marks

of the design, which indicate the lifts of the figuring harness, are cut on the middle eight rows of the card, while the special marks, represented by dots, which show the lifts of the doup harness, are cut on the first and tenth rows. That is, dots

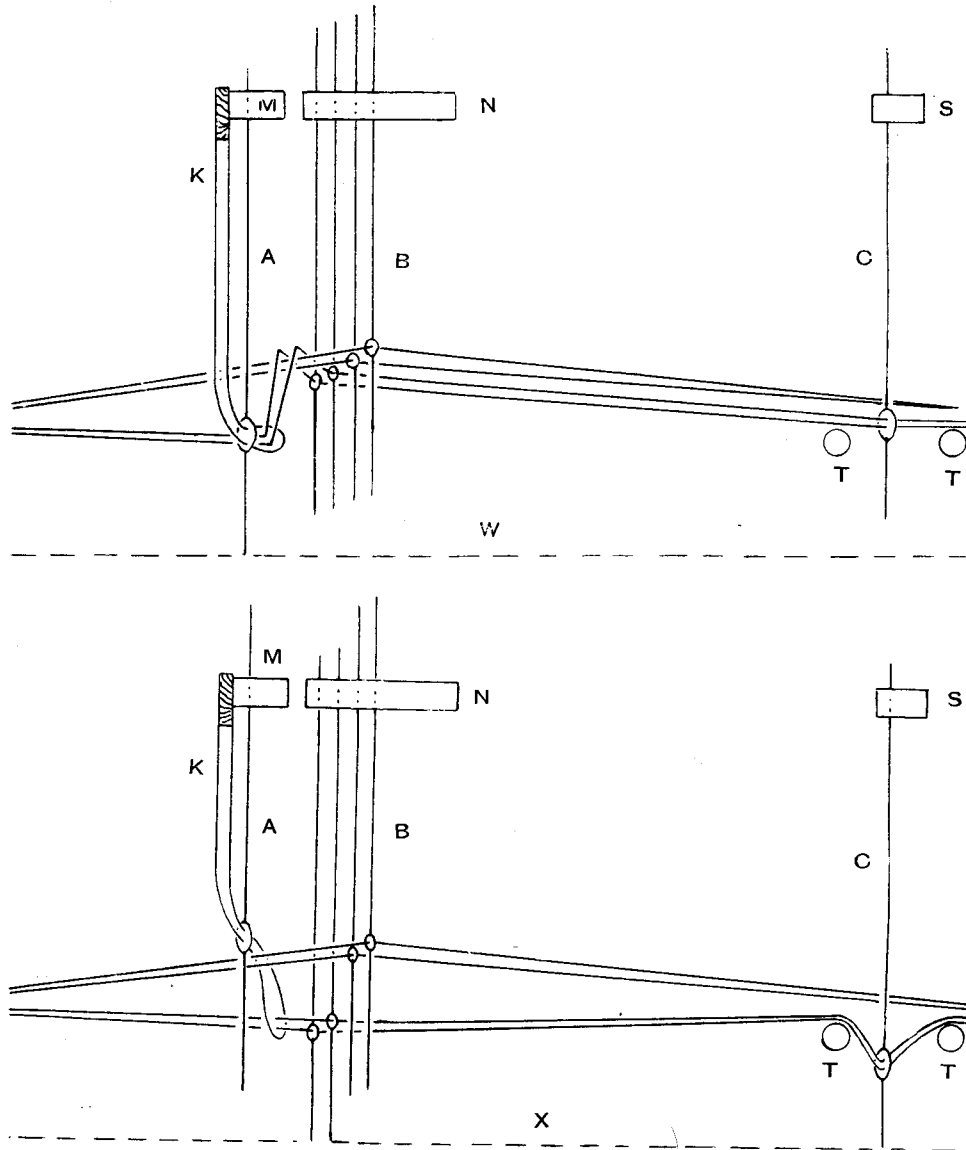

Fig. 300.

on the first vertical space are cut on the first row and on the fifth vertical space on the tenth row. If the weft is painted, as shown at C in Fig. 299, the only difference is that the blanks are cut on the middle eight rows of the card.

Top Douping in the Gauze Harness.—This system is only employed to a limited extent as compared with bottom douping. It has the advantage that the doup

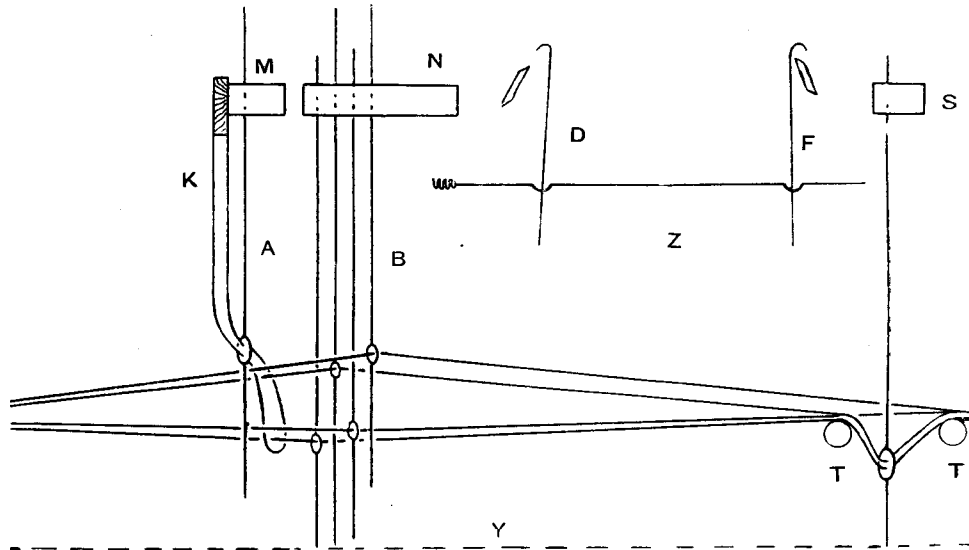

Fig. 301.

leashes cannot fall out of reach of the operative, and are in a convenient position for repairs to be effected; the jacquard and harness lift, however, is much heavier

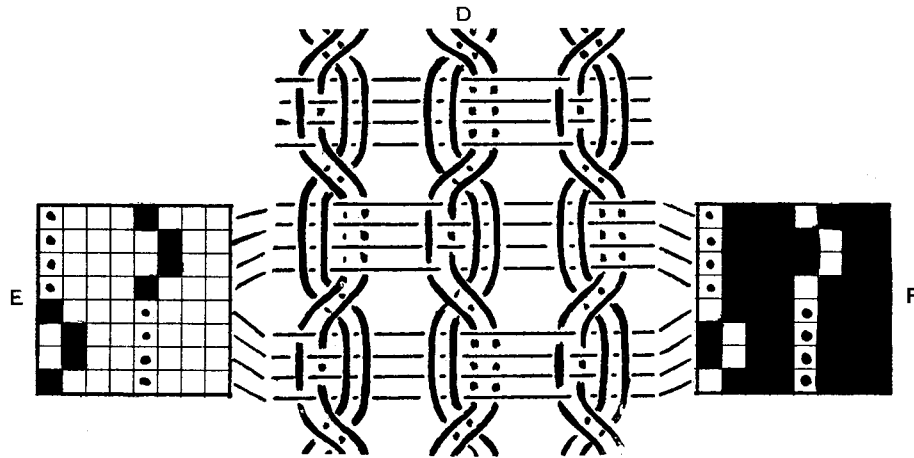
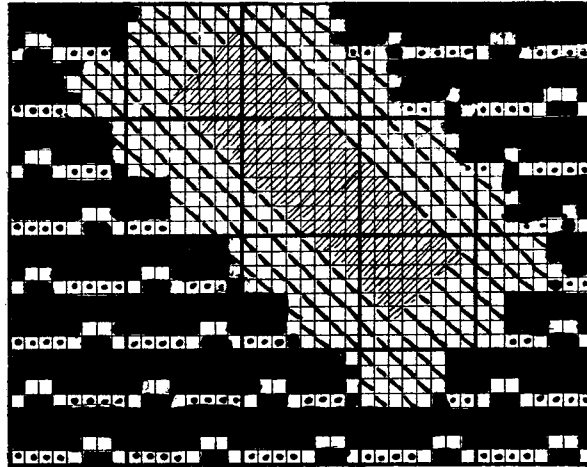

Fig. 302.

than in bottom douping. The lath of the half-heald in this case is usually fixed to the front of the doup harness comber-board. The doup harness mails are tied up about $\frac{1}{4}$ inch higher than the figuring harness mails, while specially heavy doup

harness lingoes are employed. The draft is the same as in bottom douping, except that the crossing ends are drawn over the standard ends.

The different sheds, as formed by a group of four ends, are illustrated in Figs. 300 and 301, from which an idea of the various lifts will be obtained ; the parts are lettered to coincide with Figs. 293 and 294. The drawing W in Fig. 300 represents



H

Fig. 302A.

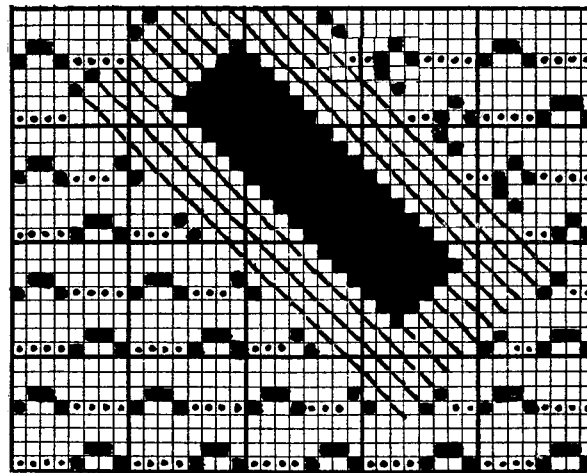

G

the formation of a crossed shed, in which both the crossing and the standard ends are raised by the figuring harness B. The easing harness C is also raised, but the douping harness A is left down. As the shed is being formed the crossing ends are retained by the douping harness on the crossed side of the standard ends.

The drawing X in Fig. 300 represents the formation of an open gauze shed, in which only the standard ends are raised by the figuring harness B ; the douping

harness A is also raised, but the easing harness C is left down. The crossing ends are retained by the figuring harness on the open side of the standard ends, while the mails of the doup harness are slipped up the half-heald leashes; each pair of standard ends is raised between a leash of the doup and a doup harness cord.

At Y in Fig. 301 the formation of a figure or plain shed is represented, which is very similar to an open gauze shed. The figuring harness mails are lifted where required (as in ordinary figuring), the doup harness A is raised, and the easing harness C left down. Lifting the doup harness enables the crossing ends to be raised by the figuring harness without obstruction. If one crossing end of a pair is required down and the other up, the latter slides within a loop of the half-heald, as shown in Y, but if both crossing ends are raised the loop is carried to the upper line of the shed.

It will be noted in top douping that when the doup harness is raised the easing harness is left down, and *vice versa*. The same needle controls both a douping and an easing hook, and it is therefore necessary for one series of hooks and lifting knives to be turned the opposite way to the other series. Either series may be inverted, but for convenience in the designing and card-cutting it is better to reverse the doup needles and knives, in the manner represented at Z in Fig. 301. The card-cutting particulars are then the same as in bottom douping, holes being cut for the cross sheds, and blanks left for the open sheds on the first and tenth rows of the card. The gauze styles illustrated in Fig. 295 will be produced the other way up in top douping by cutting the blanks and dots on the middle eight rows of the card, and the dots on the first and tenth row.

D in Fig. 302 represents a top doup gauze effect, which corresponds with the structure given at C in Fig. 295. The plan E shows how the weave is indicated if weft is painted, and F if warp is painted. G and H in Fig. 302A respectively show the weft and warp methods of designing a figure, from which it will be seen that in this case fewer marks are required in painting for weft, which is, therefore, the more convenient method. The example is similar to that given in Fig. 299, with which comparisons may be made. The figure is in weft float, and the card-cutting particulars for G are cut blanks and dots, and for H cut marks (except the shaded squares) on the middle eight rows of the card; the dots are cut on the first and tenth rows in both cases.

The special gauze harness is not limited to effects in which two cross two. Other arrangements can be woven by casting out the harness in long rows. For example, one-crossing-one styles can be produced by casting out one-half, and one-crossing-two effects by casting out one-quarter of the figuring harness rows, while by casting out one-half of the doup harness and easing mails two-crossing-six effects can be woven.

MADRAS GAUZE FABRICS

Structure of the Cloth.—In the Madras muslin texture a gauze foundation, which is formed continuously throughout the cloth, is ornamented with extra weft. Fig. 303 shows the appearance of a typical fabric, as viewed from opposite sides, while the diagram No. 1 in Fig. 304 illustrates the interlacing of the threads. The warp consists of crossing ends and standard ends arranged one-crossing-one, and in the gauze structure, which is very light and open, there is one ground pick in each shed. The extra weft is softer spun and usually much thicker than the

ground weft; it is interwoven with the warp where required, and floats loosely in the remaining parts of the design. The loose floats are afterwards cut away, and a texture with an opaque figure on a transparent gauze ground, or *vice versa*,

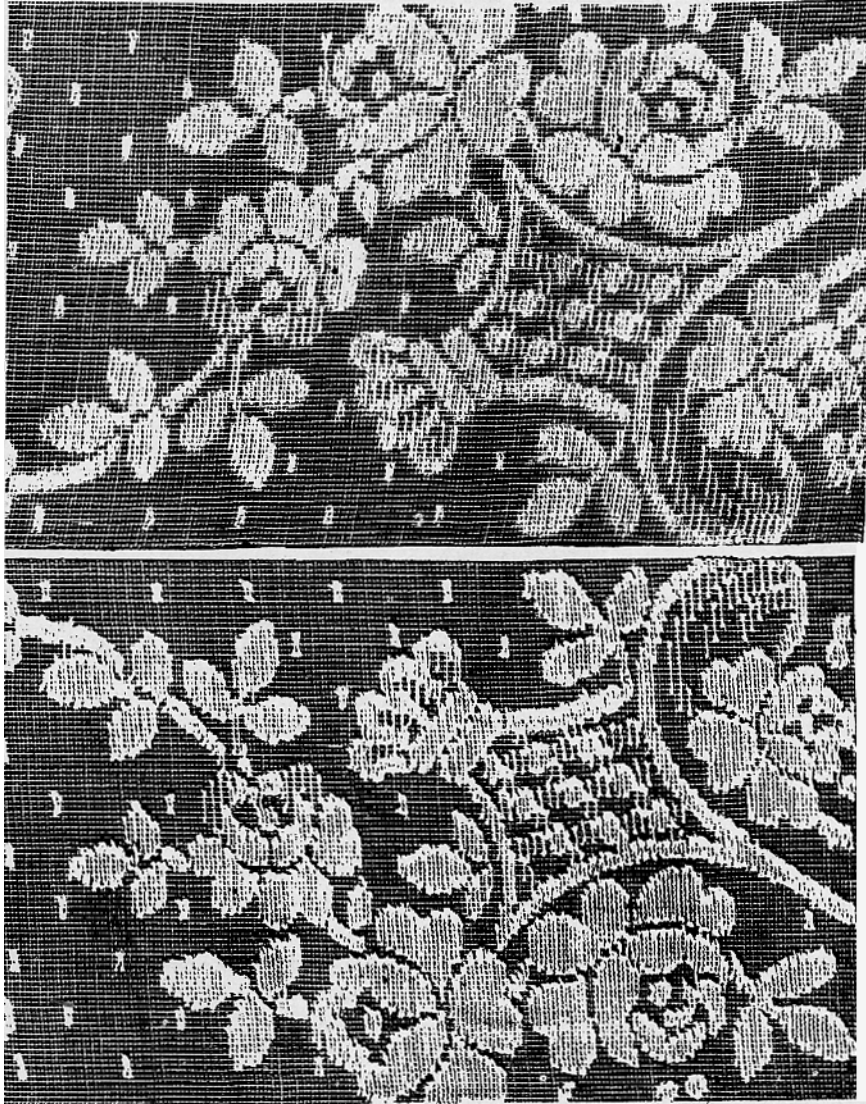

Fig. 303.

results, which is particularly serviceable for use as window curtains. The appearance of the cloth after the cutting operation is represented in Fig. 303, which shows, on the left, the fabric as viewed from the cut side—that is, the side on which the extra picks float loosely during the weaving of the cloth, and on the right, as viewed

from the uncut side. Most frequently the cloths are woven with the cut side uppermost, but they are produced to a considerable extent in the reverse way. The latter method, however, causes the jacquard lift to be very heavy. When used as window curtains, either side of the cloth may be taken as the right side, but, as shown in Fig. 303, the ornament has a bolder outline on the cut than on the uncut surface, hence for certain purposes the cut side is taken as the right side. The uncut surface, however, is neater, and for such cloths as dress fabrics, for which the structure is to some extent adapted, this is mostly taken as the right side.

The Madras Loom.—Special types of looms have been built for weaving the cloth. The following illustrations and description correspond with one of the

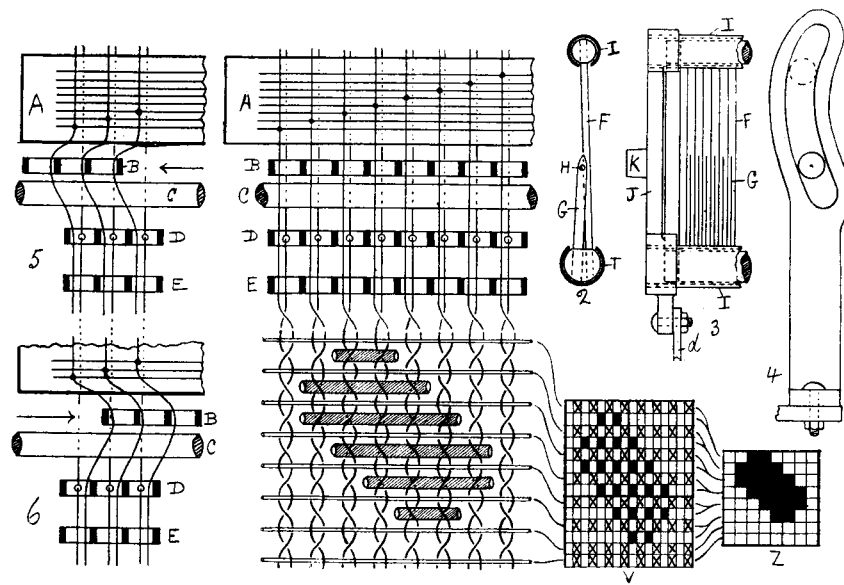

Fig. 304.

most recent systems, and, although the motion dealt with may differ in details from others that are in regular use, the principles are the same in every case. In the diagram No. 1 in Fig. 304 the structure is represented from the same side as the cloth on the left of Fig. 303, *i.e.*, as viewed from the cut side. When the texture is woven with this side uppermost the crossing ends are raised and the standard ends are left down on every ground pick. On the figuring picks all the crossing ends are left down, but the standard ends are raised where the extra weft has to be interwoven, and the latter is, therefore, firmly bound in between the standard and crossing ends. The plan given at Y corresponds with the effect shown in the diagram No. 1; the full squares indicate the lifts of the standard ends and the crosses of the crossing ends. The crossing ends, however, are operated independently of the jacquard harness, while no standard ends are raised on the ground picks; therefore in constructing a card-cutting plan it is only necessary to indicate the lifts of the standard ends on the figuring picks, as shown at Z, which illustrates the usual method of designing a figure.

System of Drafting.—An ordinary form of double-lift jacquard and harness is generally employed, but in front of the harness A there are, in the following order, a tug reed B, an easing bar C, a gauze reed D, and an ordinary weaving reed E. These are represented in the diagrams given in Figs. 304 and 305, while the draft of the ends is indicated in the upper portion of No. 1 in Fig. 304. The standard ends are drawn through the harness mails, and then are passed through the reed B, above the bar C, and through the reeds D and E. The crossing ends are passed between the harness cords, under the tug reed B and the bar C, then through eyes in short wires in the gauze reed D, and afterwards each end is passed along with its accompanying standard end through a split in the weaving reed E.

Method of Crossing the Ends.—The crossing of the ends is effected by means of the tug reed B and the gauze reed D. The tug reed is about 5 inches deep on the wires and is of ordinary form, except that each end piece is about 1 inch wide and is provided with a hole to which a chain connection is made, as shown in Fig. 306. This reed is suspended by wires in front of the harness, and by means of the chain connections it is moved about $\frac{3}{4}$ inch to left and to right on succeeding ground picks. The form of the gauze reed is shown separately in the diagrams 2 and 3 in Fig. 304. Between each pair of long wires F there is a short, pointed wire G which is slightly inclined, and is provided near the top with an eye H through which a crossing end is drawn. The baulks of the reed are slid within close-fitting metal cases I, and at each side the latter are secured by pins inside holes bored in a metal end piece J. The arrangement of the parts makes the reed very strong and rigid. Each end piece J is provided with a stud K, which fits within a curved slot formed in a guide, as shown in diagram 4 in Fig. 304. The gauze reed is raised and lowered on each ground pick, during which the studs K slide within the curved slots so that the movement is slightly circular. When the reed is down the points of the short wires G are below the lower line of the shed, as shown in diagram No. 7 in Fig. 305. When it is raised all the crossing ends are lifted sufficiently high to form a shed for the shuttle to pass through in front of the weaving reed E, as shown in No. 8. Each time the gauze reed is lowered the tug reed is moved laterally, and the standard ends, which pass through the latter reed, are pressed by the wires and traversed to left or to right. This is illustrated in the diagrams 5 and 6 in Fig. 304, in which small circles represent where the crossing ends pass through eyes in the short wires of the gauze reed. Diagram 5 shows the tug reed moved to the left and diagram 6 to the right, so that each standard end is moved above the point of a short wire of the gauze reed from one side to the other. Hence on succeeding ground picks, as the gauze reed rises it lifts the crossing ends first on the right and then on the left of the standard ends, in which positions they are bound in by the ground weft. The movement illustrated in the diagram 5, will take place previous to the insertion of the odd ground picks of the structure represented in diagram 1, and in the diagram 6, previous to the insertion of the even ground picks.

Method of Easing.—The easing bar C, to which the term dipping tube is applied, has an important function, as will be seen from a comparison of its position in the diagrams 7 and 8 in Fig. 305. The bar rises and falls on each ground pick in coincidence with the movement of the gauze reed, and maintains a uniform tension on the crossing ends.

Arrangement of Shuttle Boxes.—The Madras loom is made with four boxes at each side (sometimes only two are employed), but the two series of boxes are

connected so that they rise and fall together. Not more than three figuring shuttles, as well as the ground shuttle, can, therefore, be employed at the same time, but in different parts of a design it is possible to employ the ground shuttle only or to insert one, two, or three extra picks to each ground pick according to requirements. The box motion is governed by the jacquard cards through four needles and hooks that are set aside for the purpose. The position of each box is directly controlled by the allotted needle and hook, but the lift for a given box is cut on the card for the pick preceding that for which the box is required. Thus, assuming that three figuring wefts are inserted to each ground pick, and the boxes are operated in the order of 2, 1, 3, 4, a hole will be cut to operate No. 1 box on the first of each four

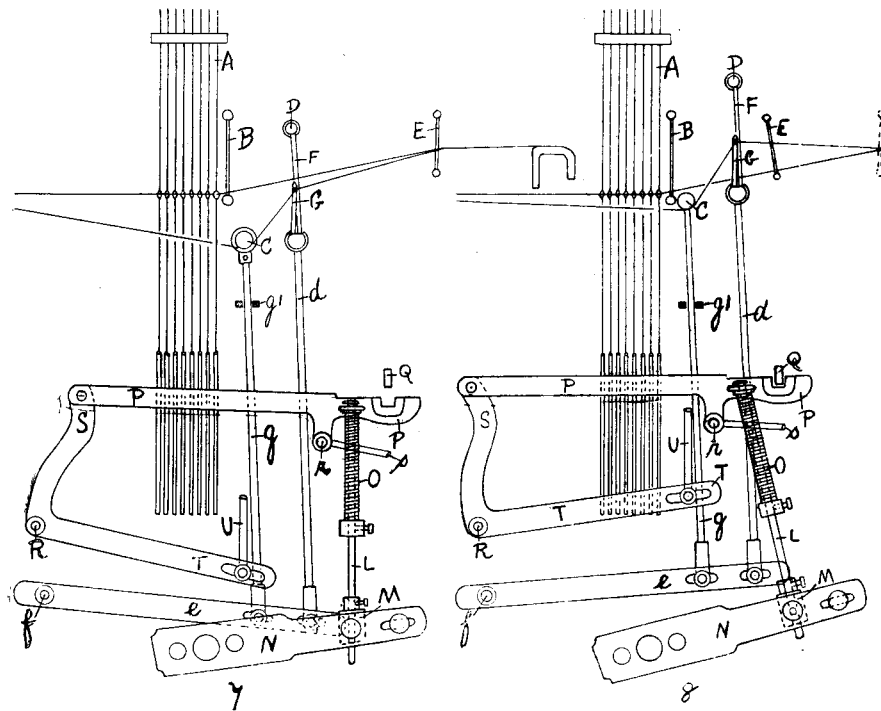

Fig. 305.

cards, No. 3 box on the second, No. 4 box on the third, and No. 2 box on the fourth. The ground weft shuttle is placed in the fourth or bottom box. The figuring wefts may be inserted in almost any sequence, but one figuring colour—usually that which is inserted most frequently and most regularly throughout the design—is taken as the leading colour, and is placed in the third box (the next box to the ground shuttle). An important feature is that when the gauze ground shuttle (the bottom box) is brought into operation the special motions of the loom are automatically put into action.

Operation of the Gauge Reed.—The rising and falling motion of the gauze reed on each ground pick is imparted by the backward and forward movement of the slay. The position of the parts, at the extremities of the movement, is repre-

sented in the diagrams 7 and 8 in Fig. 305. The lower end of a rod L passes loosely through a slot in a bracket M which is bolted to the inner side of the box lever N, while the upper end passes loosely through the slot of a projection that is connected to a horizontal lever P. Two collars are set-screwed on the rod L, the lower one of which, according to the position of the box lever N, is either just above or rests on the bracket M, while the higher one retains a spring O with its upper end against the underside of the projection on the lever P. The parts are also shown

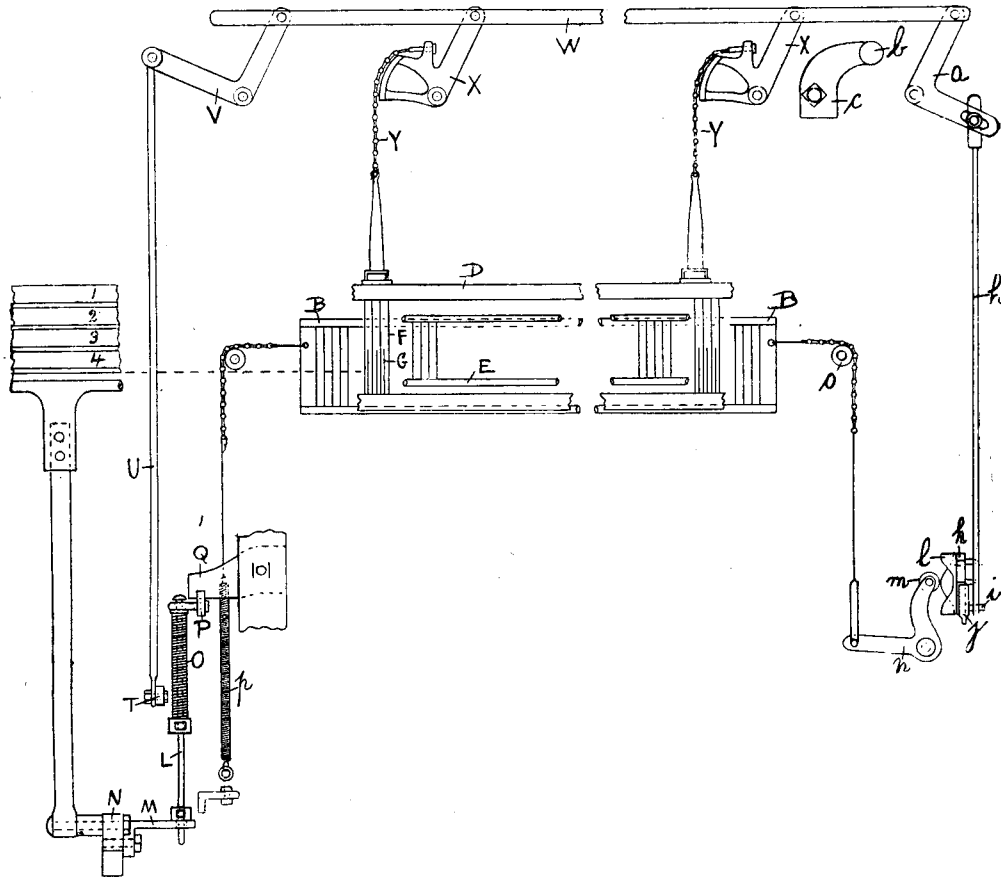

Fig. 306.

in the front elevation given in Fig. 306. When the boxes are raised to their highest position (as shown on the left of Fig. 306) so that the bottom box—which contains the ground weft shuttle—is brought into line with the race board, the upward movement of the box lever N lifts the rod L just high enough to cause the pressure of the spring O to raise the lever P at its forward extremity. This takes place at the time of beating up, when a bar Q, which is bolted to the back of a sword, is immediately above a recess formed in the upper side of the lever P, as shown in diagram 7, Fig. 305. The lever P, when raised, is brought into engagement

with the bar Q, as shown in diagram 8, and as the latter moves backward and forward with the sword, a similar movement is imparted to the lever P. A bell-crank lever, which is fulcrumed on a stud R, has its upper arm S pivotally connected to the rear of the lever P, hence the movement of the latter causes the forward end of the lower arm T to rise and fall. This movement, by means of a rod U, is imparted to the lower arm of a bell-crank lever V (shown in Fig. 306), the upper arm of which transmits a motion—to right and to left alternately—to a horizontal bar W. The lateral movement of the bar W, through the segment levers X, and the chain connections Y, causes the gauze reed to rise and fall; and this takes place with each backward and forward movement of the sword so long as the gauze ground weft only is inserted. On the insertion of a figuring pick, however, the lowering of the box lever N releases the pressure of the spring O against the projection on the lever P, the forward end of which then falls out of engagement with the bar Q, as shown in the diagram 7. The gauze reed then remains in its lowered position while the required number of figuring picks is inserted. The distance that the gauze reed rises and falls can be adjusted by altering the leverage; it is prevented from falling too far by the upper arm of a bell-crank lever *a*, Fig. 306, coming in contact with a stud *b* carried by an adjustable bracket *c*. The latter is set so as to allow the horizontal bar *w* to move the necessary distance before it is checked.

Operation of the Easing Bar.—A connection is made from each end piece of the gauze reed by means of a rod *d* to a lever *e* which is fulcrumed on a stud *f*, as shown in the diagrams 7 and 8 in Fig. 305. A rod *g*, which passes between the forks of a guide *g*¹, connects each lever *e* with an end of the easing bar C. The latter, therefore, through the levers *e*, receives a rising and falling motion which coincide with the movement of the gauze reed. Slots are provided in the levers *e* in order that the extent of the movement may be regulated.

Operation of the Tug Reed.—The lateral movement of the tug reed is obtained from the same source as the vertical movement of the gauze reed. The lower arm of the bell-crank lever *a* (shown on the right of Fig. 306) is connected by means of a rod *h*, with a stud *i*, on which a catch *j* is fulcrumed. The catch *j* engages the teeth of a six-sided star wheel *k* on the face of which there is a cam *l* that has three projections and three recesses arranged alternately. The cam *l* engages an anti-friction bowl *m* which is carried by the upper arm of a lever *n*, the lower arm of which, through a chain passing over a guide pulley *o*, is connected with one end of the tug reed B. At the opposite side of the tug reed a similar connection is made to a spiral spring *p*, the tension of which retains the bowl *m* in constant contact with the face of the cam *l*. At each downward movement of the gauze reed (which follows the insertion of a ground pick) the lower arm of the lever *a* is raised and the catch *j* turns the star wheel *k* one-sixth of a revolution. At one movement the anti-friction bowl *m* is engaged by a projection on the cam *l* so that it is pressed back, as shown in Fig. 306, the tug reed being thus drawn to the right against the tension of the spring *p*. At the next movement the bowl *m* enters a recess in the cam *l* when the tension of the spring *p* causes the tug reed to move to the left. The direction of the movement is the same as that of the preceding ground pick. (In an older motion, in place of the tug reed, a horizontal reed or ravel is employed, and between each pair of wires a short row of harness cords is passed. The comber-board is placed well above the ravel, and the latter is given a latitudinal

movement which moves the harness cords and causes the standard ends to be traversed from one side to the other, above the points of the wires of the gauze reed.)

The Picking Motion.—The direction of the pick is governed from the same source as the movement of the gauze reed. The cam *l*, Fig. 306, acts upon a second anti-friction bowl—similar to the bowl *m*—which is carried by a lever that is fulcrumed on the same stud as the lever *n*. The two bowls are on opposite sides of the cam *l*, so that when one bowl is engaged by a projection the other is within a recess. A change in the direction of the pick is, therefore, made at the same time as the tug reed is moved, and this always takes place after the insertion of a ground pick, and while the gauze reed is being lowered. When the anti-friction bowl, which governs the direction of the pick, is within a recess of the cam *l*, the picking mechanism on the right is brought into position for being operated, while that on the left is put out of action. As many figuring picks as are required, and the following ground pick, are then inserted from the right, after which the cam *l* is turned, which causes the picking mechanism on the left to be put into action and that on the right to be made inoperative. The order of picking is limited to a certain extent by the arrangement because a figuring pick from one side of the loom must be followed by a ground pick from the same side before the direction of the pick can be changed. The limitation, however, is not of great importance in weaving the fabrics for which the loom is intended. In indicating a design in which a figuring weft is introduced intermittently, it is only necessary to leave an even number of horizontal spaces between two succeeding portions of the figure produced by that weft in order to ensure that the direction of the pick will coincide with the position of the shuttle. (In a very recent device the direction of the pick is governed by the action of the shuttle box swell, and the limitation, mentioned in the foregoing, is done away with. At the side of the loom on which a shuttle is in line with the race, the pressing back of the swell, by suitable connections, causes the picking mechanism at the opposite side to be made inoperative, while the absence of a shuttle at one side brings into action the picking mechanism at the other side. In the event of anything occurring to bring a shuttle at each side in line with the race, the picking mechanism at both sides of the loom is put out of action.)

The Up-take Motion.—In different parts of a design the number of extra picks to each ground pick may vary from none to three, but it is very necessary for the foundation texture to be uniform. For this reason the up-take motion is operated from the lever *P* so that the cloth is drawn forward only when a ground pick is inserted. A projection on the lower side of the lever *P* (see Fig. 305) carries a stud *r* which is connected by a rod *s* to the lever that operates the take-up pawl. Each time the lever *P* is drawn forward the ratchet wheel of the up-take motion is turned one tooth. The arrangement ensures that the same number of ground picks per inch will be put in however irregularly the figuring weft is inserted.

Madras Designing.—Very little variation can be made in the Madras structure on account of the special means employed in weaving the cloth, and because the shearing operation makes it necessary to avoid the formation of long figuring floats on the cut side of the texture. As viewed from the uncut side, all the crossing ends (which are operated simultaneously by the gauze reed) are above the figuring picks, so that on this side the floats cannot be longer than the space between two

consecutive crossing ends. On the cut side the standard ends are above the figuring picks where the latter are interwoven, and so far as the weaving of the cloth is concerned these ends may be operated by the harness as desired. It is, however, generally recognised that in the figure the weft should pass over not more than one standard end at a place, otherwise the floats are liable to be cut away in the shearing process. Only the very simplest weave development is, therefore, possible, and the ornamentation of the texture is chiefly dependent upon the formation of different degrees of density, and upon colour. The cloth is largely made all white or cream, only one extra weft being employed; but a considerable trade is also done in fabrics in which two or three different figuring wefts are introduced on a white or coloured foundation. A large number of ends per inch cannot be employed because the fineness of the gauze reed is limited, and the setts usually vary from 32 to 50 ends per inch, the latter number being seldom exceeded. The ground picks range from 24 to 36 per inch, but the total picks vary according to the proportion of extra picks to each ground pick, and whether the extra weft is introduced regularly or intermittently. The ground yarns are mostly of very good quality and fine in counts—ranging from 60's to 90's cotton—while the soft spun figuring weft varies from 10's to 18's cotton. The following are typical weaving particulars:—Warp, 80's cotton, 44 ends per inch; figuring weft, 12's cotton; ground weft, 70's cotton; 30 ground picks per inch.

Modifications of the Madras Structure.—The most common modifications of the Madras structure, as viewed from the cut side of the cloth, are illustrated at A, E, H, L, O, and R in Figs. 307 and 308, in which the crossing ends are those which are over all the ground picks. The corresponding condensed plans on the right of the examples show how the effects are indicated on design paper for the card-cutting, while on the left the complete plans are given, the crosses in which represent the lifts of the crossing ends by the gauze reed, and the full squares and dots the lifts of the standard ends by the harness. A in Fig. 307 shows the ordinary opaque structure, and a modification in which only the alternate figuring picks are interwoven. The latter produces a semi-opaque effect which forms a pleasing contrast between the transparent ground and the opaque portions of a design, and may be used effectively in shading a figure. The marks in the plan B indicate where the standard ends are raised on the figuring picks when the cloth is woven with the cut side up. The appearance of A when turned over from left to right is represented at D; the texture is the same on both sides, except that the free ends of the figuring picks show more prominently on the cut side. In D the crossing ends are under all the ground picks.

E in Fig. 307 illustrates another method of producing different degrees of density. In this case two figuring picks of different thicknesses are inserted to each ground pick; both wefts are interwoven in forming the opaque structure but in the semi-opaque effect only the finer weft is interwoven. Two figuring cards are cut from each horizontal space of the condensed plan F, the full squares and dots being cut on the first card, and the full squares only on the second.

In the modification shown at H in Fig. 307 the density is the same as in the ordinary structure, but the figuring weft is brought more prominently to the surface on the cut side of the cloth. The standard ends are raised alternately on the figuring picks, as shown by the plain order of marks in the plan I. On the uncut side, a view

of which is given at K, the figuring weft shows less prominently than in the ordinary structure.

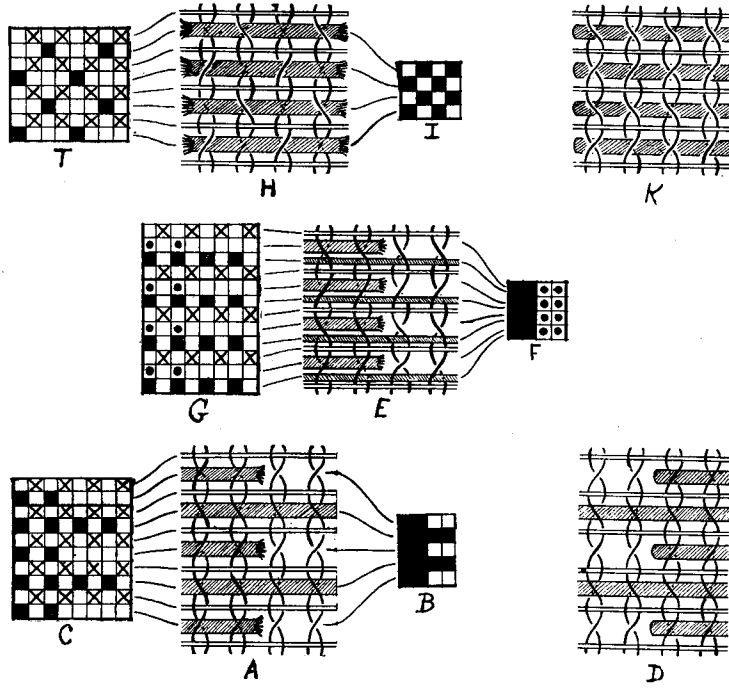

Fig. 307.

The alternate system of operating the standard ends can be effectively employed in mixing two different colours of weft in the manner represented at L in Fig. 308.

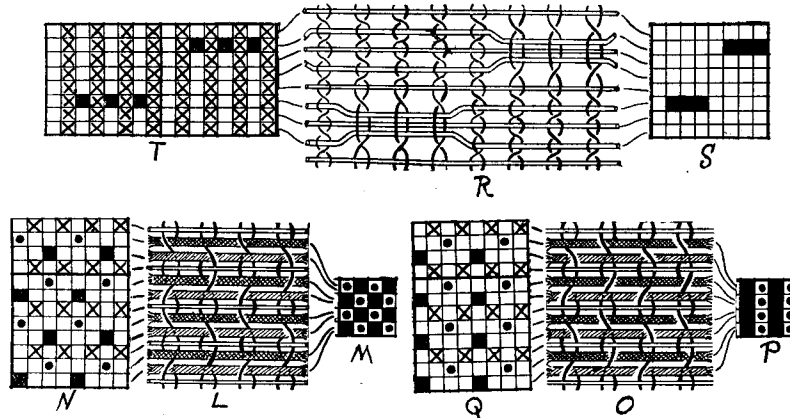

Fig. 308.

Each horizontal space of the plan M represents two figuring cards, in one of which the full squares are cut, and in the other the dots. The mixed colour

effect may be used as a subsidiary to the patterns formed separately by the two colours of weft, from which it also differs in density.

O in Fig. 308 shows another method of mixing two colours, in which each weft is bound in a straight line by the alternate ends, so that vertical lines of colour are formed. The card-cutting particulars for the plan P are the same as for M.



Fig. 309.

It will be understood that the small floats, shown in H, L, and O, remain in the cloth as they are too short to be cut away by the shears; the latter are set close enough to engage any floats that are longer than those shown in the examples.

The diagram given at R in Fig. 308 shows how the gauze ground structure may be modified by lifting certain standard ends at the same time as the crossing ends are raised by the gauze reed. This prevents a crossing taking place so that

at these places the ends lie straight for three picks which are grouped together. The marks in the plan S, which show where the standard ends are raised on the ground picks, will be cut on the ground cards, and in this respect the example is different from the foregoing styles. In weaving the ordinary gauze foundation, all the ends required up are raised by the gauze reed, so that the cards for the ground picks are blank except where holes are cut for the purpose of operating the boxes and the selvages. As regards the figuring picks, sometimes these are not interwoven with the selvages, catch ends being provided for them at each side, so that on the figuring cards, in addition to cutting the marks of the design, it is necessary to cut holes to correspond with the lifts of the selvages or the catch ends, as well as holes for operating the boxes.

Single Cover Chintzed Design.—An illustration is given in Fig. 309 of a Madras muslin texture which is termed a “single cover,” that is, there is only one figuring pick to each ground pick. Three different figuring wefts—white, green, and pink—are, however, employed, but these are chintzed, one following another in succeeding sections of the design. The ground is transparent, and in the figure, in addition to the ordinary opaque structure, effects are formed which correspond with those represented at A and H in Fig. 307. Also, for the purpose of illustration, in the lower portion of Fig. 309 a sample of a gauze ground texture is inset which is similar to the example given at R in Fig. 308. A section of the design, which corresponds with the lower central portion of Fig. 309, is indicated on design paper in

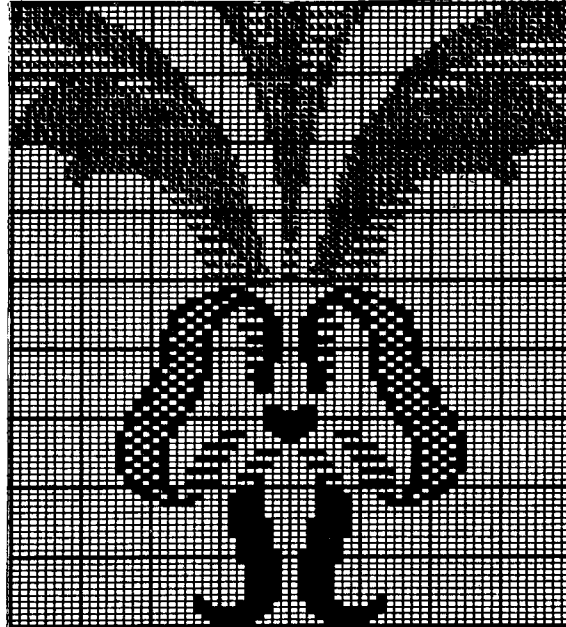

Fig. 310.

Fig. 310, the different marks representing different colours of weft. Where the ordinary opaque structure is formed the figure is simply painted in solid, but in producing the semi-opaque effect the alternate horizontal spaces only are filled, in while in bringing the weft more prominently on to the cut side a plain order of marking is employed. It is important to note that if the transparent gauze ground is required to show distinctly between two detached portions of figure formed by the same weft, the two portions must be separated horizontally by at least two blank spaces of the design paper. Otherwise the weft floats between the parts of the figure will not be long enough to be engaged by the shears, and the two portions of figure will appear to join up.

Gauze Figure on Opaque Ground.—Fig. 311 shows a Madras style in which a transparent and semi-transparent figure is formed on an opaque ground. A corresponding portion of the design is given in Fig. 312, the method of designing being the same as in the last example except that the form of the figure is represented by the blanks. A special feature in this case is the formation of a geometrical pattern on the opaque texture by floating the figuring weft over one standard end at a place on the cut side of the cloth. These floats are too small to be affected by the shearing operation, and although the pattern is almost invisible on the uncut

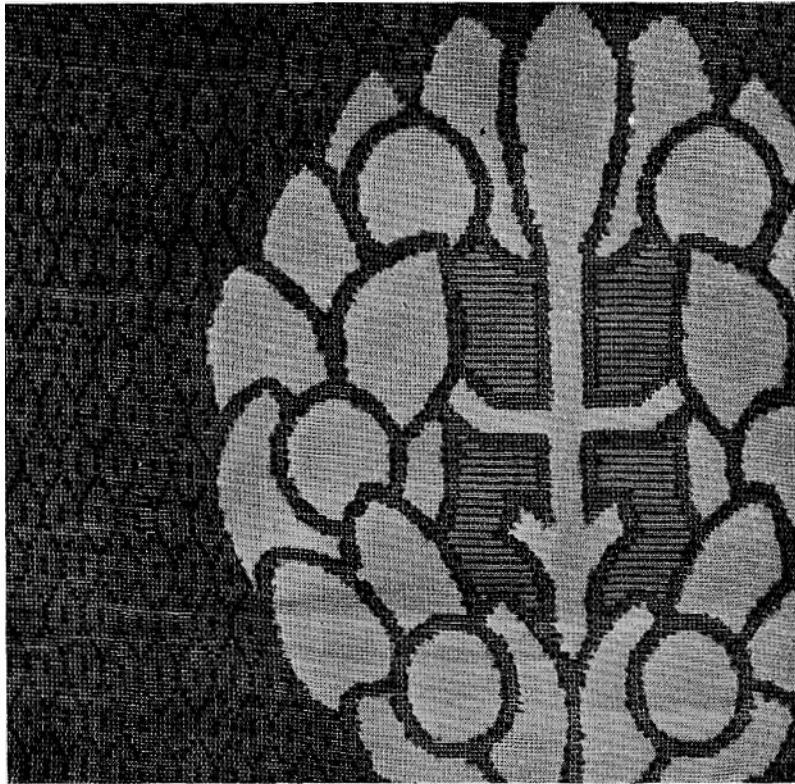

Fig. 311.

side of the texture, on the reverse side it is sufficiently prominent to relieve the stiffness of the opaque ground.

Complex Three-colour Fabric.—A more complex structure is illustrated in Fig. 313, and in the corresponding sectional plan given in Fig. 314. In this case three different kinds of figuring weft are employed, but not more than two are introduced at the same time, and in some places only one. Seven different effects, which are represented by the different marks in Fig. 314, are, however, formed. In Section A the weft is white and blue, in Section B white only, and in Section C white and heliotrope. The white weft is introduced continuously and is, therefore,

taken as the leading colour, and placed in the box next to the ground shuttle. The full squares, dots, and crosses in Fig. 314 respectively represent the white, blue, and heliotrope, where each forms a separate effect. The white and blue wefts are mixed (in the manner illustrated at L in Fig. 308) where the full squares and dots alternate in plain order, and the white and heliotrope are similarly mixed where the full squares and crosses alternate. A dividing line is formed round each mixed effect by interweaving two wefts together, the circles showing where the white and blue are interwoven together, and the vertical strokes the white and heliotrope.

System of Card-cutting.—Each horizontal space of the design represents as many figuring cards as there are colours of weft inserted to each ground pick, and

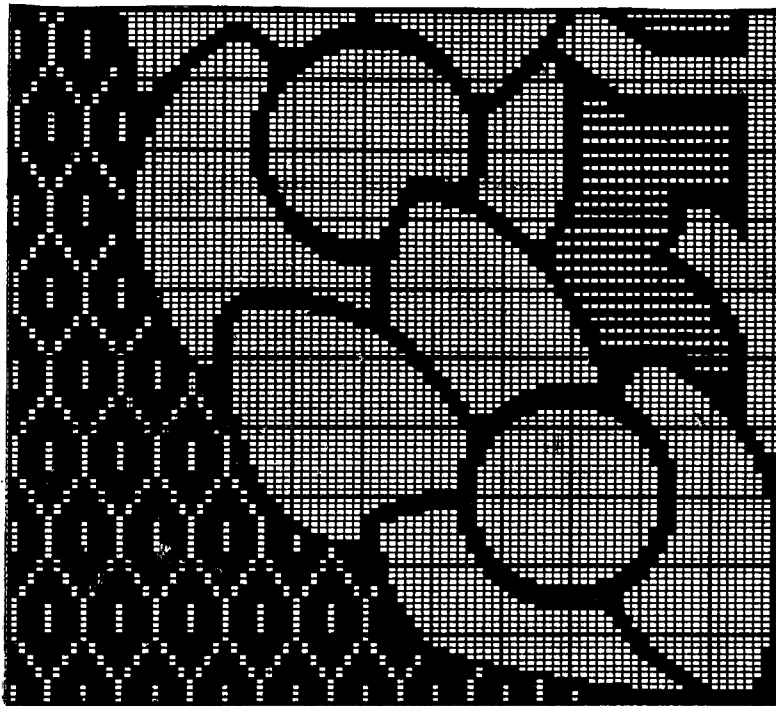

Fig. 312.

the following ground card. The pattern formed by the leading colour of weft is cut on the card which precedes the card for the ground pick. The full card-cutting particulars for the design given in Fig. 314, are indicated in the accompanying list (except that the lifts for the selvages are omitted), assuming that the ground, white, blue, and heliotrope wefts are respectively placed in the boxes Nos. 4, 3, 2, and 1.

Section A.—First card (blue weft in No. 2 box), cut the dots and circles and the lift for No. 3 box ; second card (white weft in No. 3 box), cut the full squares and circles and the lift for No. 4 box ; third card (ground weft in No. 4 box), cut the lift for No. 2 box.

Section B.—First card (white weft in No. 3 box), cut the full squares and the lift for No. 4 box ; second card (ground weft in No. 4 box), cut the lift for No. 3 box.

Section C.—First card (heliotrope weft in No. 1 box), cut the crosses and vertical strokes and the lift for No. 3 box ; second card (white weft in No. 3 box), cut the full squares and vertical strokes and the lift for No. 4 box ; third card (ground weft in No. 4 box), cut the lift for No. 1 box.

In each section the cutting is repeated for the required number of times, but



Fig. 313.

on the last ground card in Section A the lift for No. 3 box is cut, and in the last card in Section B the lift for No. 1 box, etc.

As only half the ends are operated by the jacquard harness a large repeat can be obtained from a comparatively small tie. Thus, in a cloth with 44 ends per inch, a 400 tie will give a repeat in width of $400 \div \frac{44}{2} = 18$ inches. The counts of the design paper is in the proportion of the harness ends per inch to the ground picks per inch. For example, if there are 44 ends and 30 ground picks per inch, the proportion is— $(44 \div 2) : 30$, or 8×11 design paper.

The proportion of the "cover" is found in the same manner as in book-harness muslins (see p. 174), but in a Madras design in which more than one colour is inserted to a ground pick, it is necessary to count the colours separately on each horizontal space. Thus the last example is a "double-cover" except in the parts (lettered B in Fig. 314) where only one figuring weft is inserted.

In a recent development of the Madras structure the cloth is made perfectly reversible with the figure in different colours on opposite sides. Two figuring picks in different colours are inserted to each ground pick, on one of which alternate

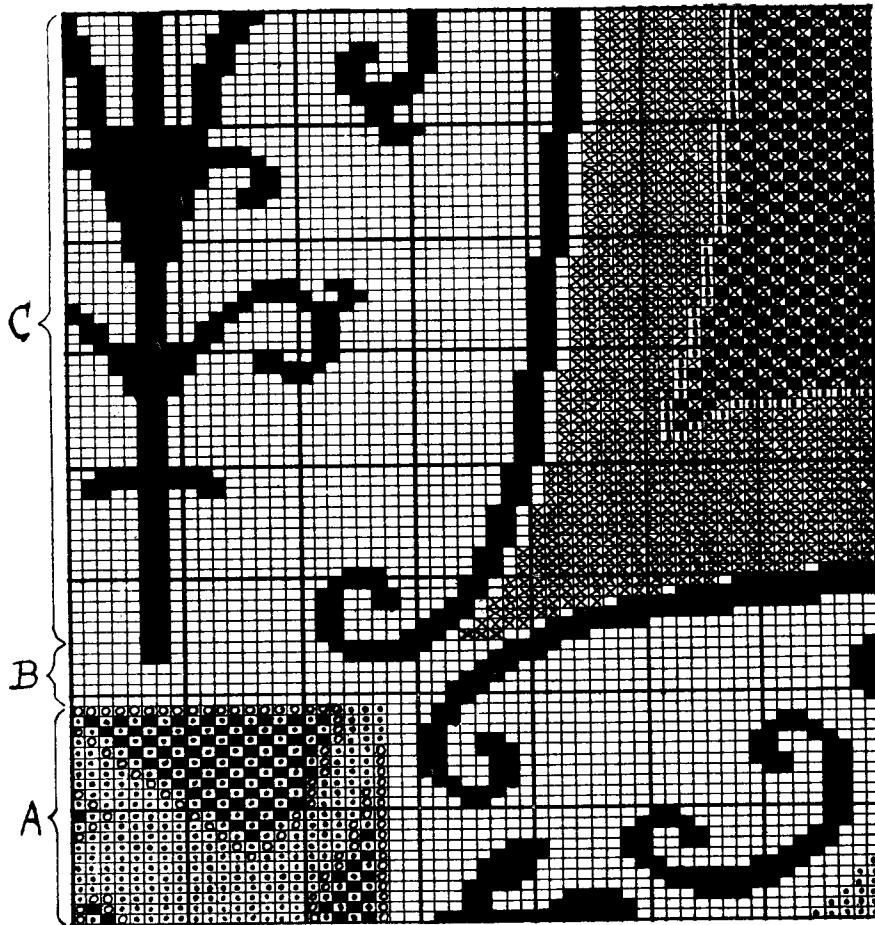

Fig. 314.

standard ends are raised by the harness in the ordinary manner where the figure is required to be formed. On the other pick all the ends are raised except alternate standard ends in the figure, which is accomplished by lifting the gauze reed, all the standard ends in the ground, and alternate standard ends in the figure. Loose

floats of weft extend between the parts of the figure on both sides of the cloth, so that a double cropping operation is required. One figuring weft shows prominently on one side, and the other on the other side, because each passes over the alternate standard ends and all the gauze ends on the side on which it forms the figure.

CHAPTER XIV

LAPPET WEAVING AND DESIGNING

Features of Lappet Figuring—Scotch Lappet Wheel Loom. *Common Wheel Lappet System*—Rotation of the Pattern Wheel—Vertical Movement of the Pin and Needle Bars—Method of making the Needle Bars Inoperative—Lateral Movement of the Needle Bars—Relation of Movement of Shifter Frames to Rotation of Pattern Wheel—Construction of a “Common” Lappet Wheel—Methods of Indicating Lappet Designs—Method of Indicating a Pattern Groove. Continuous Two-frame Lappet Design—Relative Positions of the Needle Bars and Pecks. Intermittent Three-frame Lappet Style—Continuous All-over Three-frame Lappet Design. Crossing the Needle Bars. To find the Diameter of a Wheel—The Length of Repeat. Methods of Diversifying Lappet Designs—Spacing the Needles in the Bars. *Presser Wheel System*—Construction of a Presser Wheel—To find the Length of Whip Warp—Lappet Styles in Imitation of Net Leno—Waved Russian Cords. Imitation Lace. Patterns produced by varying the Order of Lifting the Needle Bars.

Features of Lappet Figuring.—In this system of weaving, the special features of which are illustrated in Fig. 315, figuring or “whip” threads are introduced as extra warp on a foundation fabric. In forming the figure these longitudinal threads are traversed in a horizontal direction on the face side of the cloth, and are bound

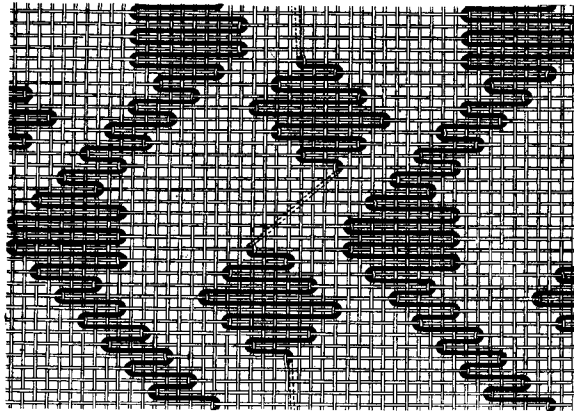
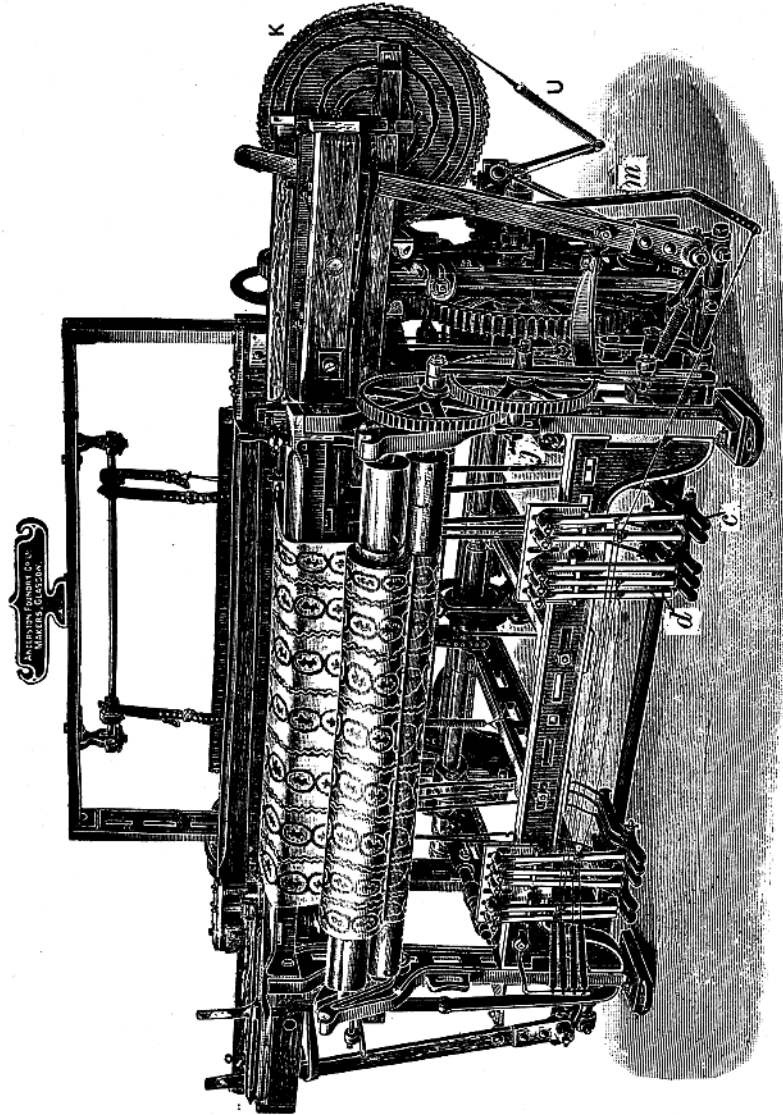

Fig. 315.

to the latter by a weft pick at the extremity of each traverse. On account of the manner in which the horizontal movement is imparted to the whip threads, it is impossible for the floats to be stitched to the ground texture except at each extremity; therefore a figure, or a part of a figure, formed by one thread cannot be submitted to any form of interlacing. Any kind of ground weave may be employed but as the foundation requires to be very

firm, in order that the ground ends will not be unduly disturbed by the side pull of the whip threads, plain or gauze ground is usually employed. One repeat of the pattern is limited to from one to usually not more than four different orders of working, while compared with jacquard figuring the number of picks in the

repeat is also restricted. The mechanisms employed, and their adjustment, are of a nature that renders it almost impossible for such accuracy to be obtained as will ensure that succeeding repeats of a design are exactly the same, and the outline of a figure has a somewhat steppy appearance. In spite, however, of the



many limitations thus imposed upon lappet ornamentation, by skilful arrangement great diversity of design can be produced.

In order that the principles of designing for the styles may be thoroughly understood, some knowledge of the means by which the whip threads are operated is necessary. The features which have to be regarded by the designer, however,

vary somewhat according to the class of lappet mechanism which is employed. The Scotch lappet wheel system is most commonly used, and this type of loom, and the styles produced upon it are, therefore, described and illustrated. Many of the parts of this motion are common to all lappet mechanisms, the differences between which are chiefly due to the method in which the horizontal movements are imparted to the whip threads.

Scotch Lappet Wheel Loom.—Fig. 316 gives a general view of a four-frame left-hand lappet wheel loom (as constructed by the Anderston Foundry Company, Limited, Glasgow), in which some of the parts are lettered to correspond with the drawings in Figs. 317 and 318 in order that their position and method of operation may be compared. Various parts of the mechanism are represented in side elevation in Fig. 317; also in front elevation in the upper portion of Fig. 317, and in plan in the lower portion. The parts are to scale, except that certain features are accentuated, and while the description is of a four-frame loom the duplication of the mechanism, in all cases, is not shown.

The lappet wheel system has obtained its name from the use of a wheel K as the means of governing the horizontal movements of the whip threads in forming the pattern. There are two kinds of these pattern wheels—viz., (1) A “common” wheel used for styles in which the whip threads are moved alternately to the left and to the right on succeeding picks, and produce figures which are more or less massive. (2) A “presser” wheel which is employed when in some part of a design a whip thread is required to move in the same direction on succeeding picks—as, for example, in forming a fine line of figure running more or less in a diagonal direction across the cloth. The latter is less extensively employed than the former, and as its use necessitates certain modifications of the loom to be made, the ordinary or “common” wheel lappet system will be considered first.

“COMMON” WHEEL LAPPET SYSTEM

Fig. 315 illustrates the style of lappet design produced by a common wheel. The figure, which is represented as being formed upon a plain foundation, results from the combination of two orders of working, one of which produces a continuous waved line effect, and the other a spot effect. The manner in which the whip threads are stitched in by the picks, and exert a side pull on the ground ends, is indicated, and it will be noted that in plain ground the effective distance traversed by a whip thread is always equal to the space occupied by an even number of ground ends. A traverse of an odd number, in plain ground, is impossible, as in such a case the interlacing of the ground ends will permit the whip thread to slip over one end; and for this reason, on a plain foundation, the moves at the edge of a figure are always in even numbers.

The whip threads are carried by eyed needles A (Figs. 317 and 318) fixed in the needle bars B, each of which is separately supported by a shifter frame C. Although a loom is usually fitted with four needle bars and shifter frames, only as many are employed as are necessary in forming a design, the remainder being left out of action. The distance that the needles project varies with the position of a bar, and may be 3 inches in the first bar, and project $\frac{1}{8}$ inch farther at each succeeding bar, in order that they will conform with the line of the shed. The needle bars are below the ground warp threads—the cloth being woven wrong side up, and each bar, when in action, has a sequence of the following movements:—

(1) A rising movement to bring the needle eyes about level with the top line of ground threads, in which position they are retained while a weft pick is inserted to stitch the whip threads into the ground fabric. During this movement the reed is moving back from the edge of the cloth. (2) A falling movement, during which the reed is moving forward, which brings the needles below the lower line of warp. (3) A horizontal movement to the left, by which the whip threads are traversed for the required distance in forming the pattern. The rising movement is then repeated, and the whip threads are stitched in by the second pick in their new position; the needles fall again, and this is followed by a fourth movement in which the bar is traversed to the right.

As the needle bars B are required to raise the needles into the shed opening in front of the reed, it is necessary for the latter to be placed back from the race-board. The lower part of the reed is, therefore, carried in a semi-circular trough D, Fig. 317, which is supported by brackets, one at each side of the reed space. The brackets are secured by bolts to the slay, while the slay cap E, which holds the upper part of the reed, is also fixed behind the slay by means of bolts. The position of the reed necessitates the provision of a bar F, Fig. 317, termed a pin bar, that carries a number of vertical pointed pins placed about $1\frac{1}{4}$ inches apart, which, at every pick of weft, are projected into the shed opening in close touch with the back edge of the race-board. The pin bar simply rises and falls, and has no part in the formation of the pattern. The function of the pins is to serve as a false reed, in place of the ordinary reed, in guiding the shuttle in its passage across. The pin and needle bars move to and fro with the slay; and in Fig. 317 they and their supports are represented in their most backward position by the solid lines. The dotted lines show their position when the reed is in contact with the cloth. On account of the reed being placed back, a much longer sweep of the slay—about 8 inches—is necessary than in ordinary looms. Instead of the ordinary cranks, the fast pulley and the gear-wheel to the bottom shaft are placed at opposite extremities of the driving shaft, and are provided with bolt holes, the bolts in which form the fulcra of the connecting arms.

The threads for each needle bar are wound on a separate small beam, and in mounting the loom the rolls are placed in suitable supports G, Fig. 317, bolted to the loom framing. The whip threads from each roll are passed in front of the lower and behind the upper cord of a tensioning arrangement H, between the heald cords, then under the reed casing, and finally are drawn through the eyes of the corresponding needles. A separate tension device H is required for each needle bar, because the length of the whip thread, from the cloth to the roll, varies with the rise and fall of the bar. Delicate adjustment of the tension is necessary in keeping the whip threads sufficiently tight to prevent them from curling on the face of the cloth, while at the same time the ground texture is disturbed as little as possible. The parallel cords of H, which extend across the warp, are attached to wooden end pieces, and are given the necessary spring as follows:—The ends of a strong cord are passed inward through two holes equidistant from the centre of each end piece, and are secured. The looped end of each cord is then passed through a hole in a bracket, and a small piece of wood is inserted in the loop. By turning the pieces of wood round, twist is put into the cords, the amount of twist being varied according to the degree of tension required. The spring cords readily give off and take up the whip warp in accordance with the movements of the needle bars.

Rotation of the Pattern Wheel.—The wheel K, Fig. 318, made of hard wood about $\frac{1}{8}$ inch thick, is mounted behind the shuttle box with its centre rather higher than the upper side of the shifter frames C. Its central stud is supported by means of a bracket bolted to a slotted rail z (fixed by a bolt to the sword) in such a manner that lateral adjustment, according to the size of the wheel, is readily made. A number of teeth, equal to, or a multiple of, half the number of picks in the repeat of the design, are cut on its periphery, and it is turned one tooth at every two picks, as follows:—A bowl L, adjustably carried by a bolt fixed in a slot in the low shaft gear-wheel, engages the surface of a flat plate screwed on the upper side of a lever

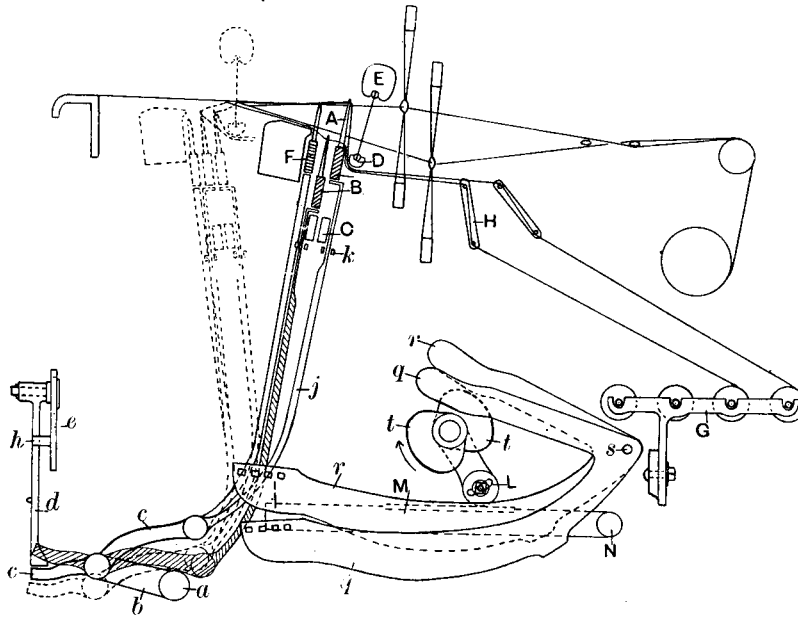

Fig. 317.

M, fulcrumed at N, Fig. 317. The lever M is thus depressed once in two picks, and by means of the connecting rod O, Fig. 318, lever P, and catch holder Q, the spring catch R is raised high enough to engage the next tooth. Immediately the bowl L has passed the centre of its action on the lever M, the downward pull of a strong spiral spring S causes the catch R to be depressed, and the wheel is thus rotated one tooth. The height to which the spring catch R is raised is varied in accordance with the pitch of the teeth, and the downward pull of the spring S is arranged to bring the edge of a tooth in a horizontal plane with the centre of the wheel. In order to prevent the wheel overrunning itself, its rim at the back is cut away to about the depth of the teeth, and in the surface thus provided a groove T is cut for the reception of a brake cord. The cord is tied at one end to a bracket, and at the other end is connected to a spiral spring U, the pull of which is regulated according to requirements. The catch R is raised while the crank is moving from the back to the top centre, and its downward movement is completed before the front centre is reached.

Vertical Movement of the Pin and Needle Bars.—The pin bar F is mounted

at both ends with grooved brasses which fit freely over slides on the inner ends of the shuttle boxes. Each needle bar B is similarly provided at its ends with grooved brasses, as shown at V in Fig. 318, which, in this case, fit over flat vertical slides W, screwed to the top of the corresponding shifter frame C. This arrangement permits a vertical movement to be imparted to the needle bar, quite independently of its shifter frame, while the horizontal movement of the latter will be communicated to the needle bar. At the same time that a needle bar is required

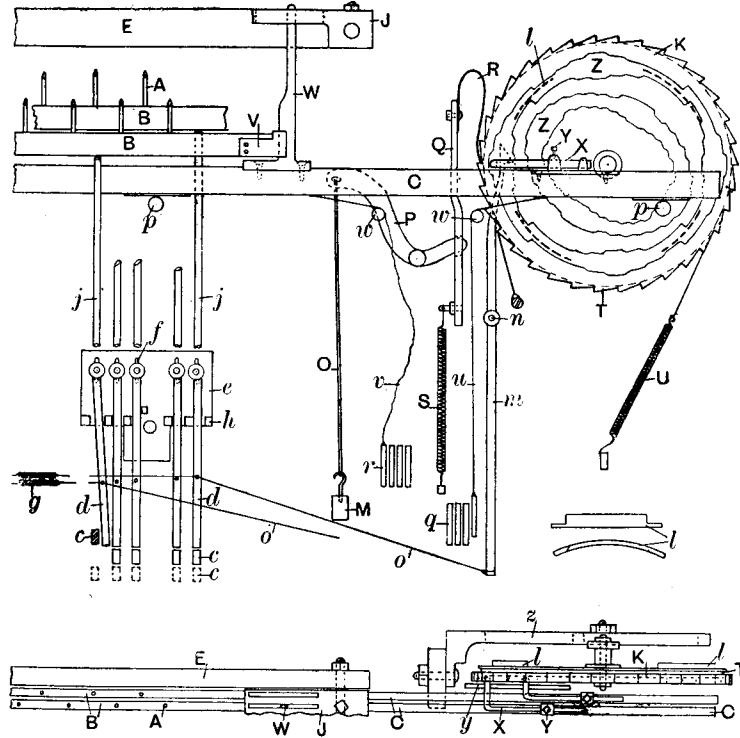

Fig. 318.

to slide freely in a vertical direction, it is important that there be no side play between the brasses and the slides, or the horizontal movement will be affected. To compensate for the wear of the brasses and slides a flat piece of wire may be attached to the end of a bar and passed inside the brass groove.

The pin bar must be raised and lowered on every pick; and the same applies to a needle bar which is forming a continuous line of figure, such as is shown in Fig. 315. The needle bar, which produces the detached spot effect in the same design, however, will require to be thrown out of action on the picks between the spots. It is, therefore, necessary, so far as its vertical movement is concerned for each needle bar to be capable of being put into or taken out of action when required. In Fig. 317, with the slay in its backward position, one needle bar is represented as being raised, while the other is down. The bars derive their rising and falling movements from the rocking shaft *a*, Fig. 317, the partial turning of

which causes the lever *b*, fixed to it, to rise and fall at its forward end. This end of the lever *b* carries a stud upon which five levers *c* are fulcrumed, the central lever being used for the pin bar, and the two on each side of it for the four needle bars. Above the front edge of each lever *c* there is a pendant *d*, carried by a slotted bracket *e*, which is bolted to the loom framing. The pendants are fulcrumed at the top, and while that for the pin bar is always over the front edge of a lever *c*, those for the needle bars are retained in their normal position by a cord connected to a spiral spring *g*, shown in Fig. 318. Projections *h* are cast on the bracket *e* in order to limit the lateral movement of the lower ends of the pendants. At the rear end of each lever *c* the extremity of a round rod *j* is fulcrumed, each rod passing through guide slots *k* to the underside of a bar. The rod, which controls the pin bar, does not need to be specially shaped at the top, but on account of the shifter frames being below the needle bars, the other rods are made flat towards the top, and are bent at right angles where they are in contact with the bars. A set of five pendants and connections is provided at each side of the loom, as shown in Fig. 316, and a flat piece of metal is screwed to the underside of each bar where a rod *j* is in contact with it.

For convenience, in Figs. 317 and 318 the levers *c* are represented in three positions. When a bar is down, the rear end of the corresponding lever *c* rests with its underside on the rocking shaft *a*. As the slay moves back from the cloth the lever *b* rises at its forward end, and thus raises the fulcrum of the levers *c*, the front arms of which, therefore, press against, and are held down by, the pendants *d* (which are in the normal position), with the result that the rear ends rise and push up the corresponding bars by means of the rods *j*. As the slay approaches the cloth the forward end of lever *b* falls, and all the levers *c* assume the positions represented by the dotted lines, the pin and needle bars moving below the underside of the cloth. The bars should complete the downward movement when the reed is some distance from the edge of the cloth, and before the horizontal movement commences. With smooth working the deadweight of the parts is sufficient to bring the bars down, but in order to avoid all liability of a bar sticking, it is customary to attach one end of a light spring to the framework underneath, and connect the other end by a separate cord to each bar. The vertical distance moved by the bars can be adjusted collectively by turning the lever *b* on the rocking shaft *a*, and individually by raising or lowering the fulcrum of a pendant in a slot *f* provided in the bracket *e*.

Method of Making the Needle Bars Inoperative.—A needle bar is left out of action by withdrawing the corresponding pendant *d* from above the forward end of a lever *c*, which, therefore, rises as the slay recedes from the cloth. The weight of the needle bar and connecting rod keeps the rear end of the lever *c* resting on the rocking shaft, and the parts thus assume the position represented by the shaded lines in Fig. 317, the needle eyes remaining below the lower line of the warp. The manner in which a pendant is withdrawn is illustrated in Fig. 318. On the hind face of the wheel *K* a ring groove is cut, into which one or more curved pieces of metal *l*, projecting about $\frac{1}{4}$ inch, are fixed. The circumferential distance covered by a “dropper” (the shape of which is represented below the wheel in Fig. 318) is arranged to coincide with a number of teeth in the wheel, and corresponds with the period during which a needle bar will remain out of action. As the wheel *K* revolves, the edge of the “dropper” comes in contact with, and presses back the

head of a hooked lever m , fulcrumed at n , and the lower end, by means of a cord o , draws a pendant away from a lever c . The upper end of the lever m is in the form of a hook, in order that it can immediately slip over the edge of a metal piece when the stationary period of a needle bar is completed. If two or more needle bars have to be put out of action at the same time, only one set of curved pieces l , and one lever m , are necessary; but if more than one bar have to be operated intermittently at different periods, a corresponding number of ring grooves is provided at the back of the wheel, each with curved metal pieces l and a separate hooked lever m and cord connection o . The curved pieces for the different ring grooves stand out the same distance from the surface of the wheel, and all the levers m , except the first, are bent sideways at the top towards the wheel, in order that each will be engaged only by the corresponding dropper. The distance between two ring grooves requires to be large enough to allow space for the hooked head of a lever m to work without obstruction.

Lateral Movement of the Needle Bars.—From one to four grooves Z , Fig. 318, according to the number of needle bars employed in the formation of the pattern, are cut in the face of the wheel K . A groove is about $\frac{3}{8}$ inch deep, and it is shaped in accordance with the desired movement of the corresponding needle bar. A “feeler,” “pike,” or “peck” X is adjustably fixed by a set-screw Y between the flanges of a metal plate fastened on the upper surface of each shifter frame. At one end a peck is made cylindrical, and is bent at right angles in order that the cylindrical end will enter a groove in the wheel. The diameter of a peck where it enters a groove is about $\frac{1}{4}$ inch, and the length of the bent portion varies according to the position of a shifter frame; that for the back frame having a short bend, while that for the front frame is much longer. The bent portions of the pecks are supported by and slide upon a smooth steel rod y placed between the back frame and the wheel. As the positions of the pecks are fixed by the grooves in the wheel, the relative position of the needles in the different bars is regulated by moving the shifter frames, the screw Y being released for the purpose. Very fine adjustment—to the space occupied by half a split of the reed—is possible, while if considerable adjustment is necessary the flanged plate on the top of a shifter frame may be unscrewed and its position changed.

The bent end of each peck X is moved alternately to left and right within a groove Z by the downward pull of two weighted levers q and r , fulcrumed at s , Fig. 317. Two tappets t , set opposite to each other on the low shaft, act alternately on the short upper arms of the levers; thus one is raised while the other is allowed to fall. The face of each tappet t is wide enough for four levers to rest upon it. Straps u and v , Fig. 318, from the ends of the lower arms of the levers q and r , are passed over guide pulleys w , strap u passing from its guide pulley to the right, and strap v to the left. A tappet t , raising the lever r , causes a strap v to hang slack, and as at this time the other tappet allows the lever q to fall, the strap u is tightened, and the shifter frame is moved to the left. At the next revolution of the driving shaft the lever q is raised by the other tappet, and the lever r is allowed to drop; thus the strap u hangs slack and the strap v is tightened, causing the shifter frame to move to the right. The upper arm of a lever q and r , when in its lower position, does not necessarily rest on the thin part of a tappet, the weight of a lever being sustained by the strap from which it is suspended. Each strap is in two parts connected by a buckle which enables the length of the strap to be conveniently

regulated. The shifter frames slide on a number of small bowls p , a flat piece of metal being screwed to the underside of each frame where contact takes place.

The to-and-fro movement of a peck is in a line with the centre of the wheel, and its extent is limited by the width of a groove ; but the position of a peck and the corresponding shifter frame changes as the groove approaches or recedes from the centre of the wheel. The movements of the shifter frames are communicated to the needle bars by means of the vertical slides W , which move within separate slots in plates J , one of which is fixed at each side to the front of the slay cap. The needle bars taken from front to back are respectively operated from the grooves taken from the outside to the inside of the wheel. A shoulder is provided upon each slide W , in order to neutralise any tendency of a shifter frame to rise. The width of the area over which a thread can be traversed by one bar is limited by the slots in the plate J , and taking the length of a slot as $4\frac{5}{16}$ inches and the breadth of a slide as $\frac{9}{16}$ inch, which are standard dimensions, the maximum width = $(4\frac{5}{16} - \frac{9}{16}) = 3\frac{3}{4}$ inches.

In order that the whip threads will offer as little obstruction as possible to the shuttle in its passage across, the tappets t and the picking tappets are set in conjunction with each other in such a manner that the direction of the movement of the frames is the same as that of the pick which follows. Thus, the pick from the right follows the movement of the frames from the right, and *vice versa*, the inclination of the whip threads, when the shed is open, being in the same direction as the shuttle is travelling. The bowl L and the tappets t are timed with each other so that the latter are midway of their lift at about the centre of the downward movement of the catch R . The turning of the wheel K thus takes place while all the straps connected to the shifter frames are slack, and there is no tension on the pecks.

Relation of Movement of Shifter Frames to Rotation of Pattern Wheel.—The low shaft gear wheel is provided at opposite sides with slots, in which the bolts which carry the bowl L , Fig. 317, may be fixed. The turning of the pattern wheel, which occurs only once in two picks, may thus be arranged to coincide with the movement of the shifter frames, either to the right or to the left. In most designs, however, it must agree definitely with one of the movements, according to the way in which the pattern grooves have been cut. There is no hard-and-fast rule ; thus, a system may be followed, for both right and left-hand looms, of having the rotation of the wheel coinciding with the movement of the pecks—(1) from left to right, or (2) from the outside to the inside of the grooves. Each system has an advantage over the other ; thus, in the first method, a wheel can be used for either a right or left-hand loom without the timing of its rotation being changed, while in the second method the pressure on the peck, as the wheel is turning, is from the side of the groove which is farthest from the centre, and the small catches (A , Fig. 322), which it is sometimes necessary to use, are fastened on the side which is nearer the edge of the wheel. In subsequent examples it will be assumed, for convenience, that the turning of the wheel coincides with the movement of a bar from left to right.

Fig. 319 illustrates how necessary it is, in certain patterns, for the rotation of the wheel, the movements of a shifter frame, and the manner in which a pattern groove is cut, to coincide with each other. In A , which illustrates the traversing of a whip thread, as viewed from the upper or wrong side of the cloth, the vertical

spaces represent the splits of the reed, and the horizontal lines the picks of weft, the pattern extending over 20 splits and 30 picks. The whip thread is shown traversing 6 and 4 splits alternately, except where the pattern turns, in which positions consecutive moves of 6 splits are made. B shows a section of the pattern wheel in which the spaces between the dotted concentric lines correspond with the splits, and the dotted radial lines with the moves to the left of the whip threads, as shown by the connecting lines; while the thick solid lines indicate the edges of the groove, which repeats on 15 radial lines, or one-third of the wheel. The width of two splits

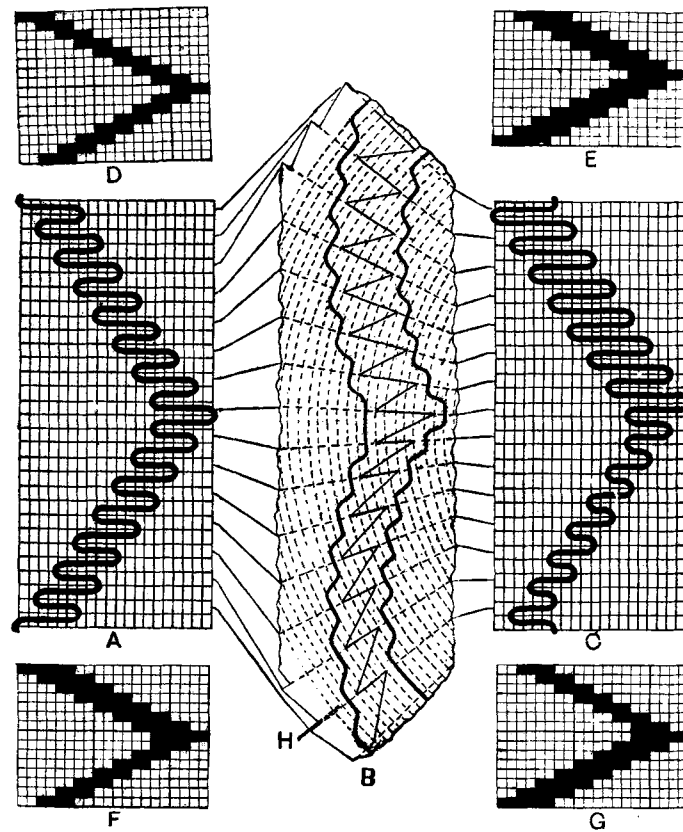

Fig. 319.

only is, for convenience, allowed for the diameter of the peck, and the groove is, therefore, shown two concentric spaces wider than the distance that the whip thread is required to be traversed. The arrangement is for a left-hand loom, and as the movement from left to right (the odd horizontal spaces of A) is taken to coincide with the turning of the wheel, the centre of the peck will traverse the concentric spaces as shown by the solid lines within the groove. It will, of course, be understood that the movement of the centre of the peck is always in a horizontal plane in line with the centre of the wheel. When the peck is moved from right to left (the even horizontal spaces of A), its centre follows a radial line, and the

lateral distance traversed by a whip thread is equal to the width of the groove minus the diameter of the peck, or $6 - 2 = 4$ splits in the lower portion, and $8 - 2 = 6$ splits in the upper portion of B. This does not apply to the movement from left to right, as while this is about to take place the wheel turns, and the peck, therefore, moves opposite a new position in the groove; the distance traversed being greater in this case where the inner edge is approaching the centre of the wheel, and less where it is receding from the centre. It will thus be noted that in order to obtain the alternate movements of 6 and 4 splits in each half of the pattern, the groove is narrower in the lower than in the upper portion of B; and a representation of the form of the groove (leaving out of account the diameter of the peck), in solid marks on design paper, will not be as indicated at D or E in Fig. 319, but as shown at F.

C, in Fig. 319, shows how the pattern would be affected if the rotation of the wheel took place at the opposite movement of the shifter frame to what the groove has been cut for. In that case the turning of the wheel would coincide with the movement of the peck from right to left, and, compared with A, the traverse of the whip threads would be curtailed by the lower portion of the groove, and increased by the upper portion. With the latter timing of the rotation of the wheel, in order to produce the effect given at A, the groove would require to be cut according to the plan indicated at G. Further comparison will show that, leaving out of account the diameter of the peck, the width of a groove is determined by the distance to be traversed at the opposite movement to that which coincides with the turning of the wheel. By noting the position of the shuttle when the catch is at its highest point, the timing of the movements can be readily determined. Thus, if the shuttle is in the left box when the catch is raised, the turning of the wheel coincides with the movement from the left, and *vice versa*.

In giving instructions for the cutting of a wheel, it is necessary for the hand of the loom to be stated, in order that the teeth may be shaped accordingly. It will be noted in Fig. 316 that the wheel is at the opposite side of the loom to the driving pulley, and the turning catch acts upon the inner edge. Frequently, however, it is necessary to use a wheel for a loom of the opposite hand to that for which the teeth have been cut. The wheel is then modified to suit by driving in staples in close contact with the edges of the teeth, as shown at H in Fig. 319. The turning catch then acts upon the projecting portions of the staples. By turning the illustration round from top to bottom, it will be seen that if the rotation of the wheel again coincides with the movement of the peck from left to right, the pattern will be exactly the same as is produced in a left-hand loom, but the peck will be against the inner edge of the groove when the wheel commences to turn. The usual effect of changing a wheel is simply to turn the figure the opposite way up.

Construction of a "Common" Lappet Wheel.—A lappet wheel is made of hard wood which is close in the grain, and well seasoned in order that it will resist atmospheric changes. Its thickness is from $\frac{3}{4}$ to 1 inch, and its diameter varies from about 8 to 25 inches, according to the number of picks in the repeat, and number of frames employed in forming a pattern. A hole is bored, about the centre of a piece of wood of suitable size, to fit the socket of a lathe, in which it is turned to the proper diameter. On the side of the wheel where the groove or grooves are to be cut, a steel comb is pressed while the disc is revolving, a number of concentric lines thus being made, the space between which corresponds with the pitch of the comb.

Combs are made to suit different reeds, and for below about 34 splits per inch it is usual to use a comb of the same pitch as the reed for which the design is intended. With more splits per inch the fineness of the marking presents a difficulty, and a comb may then be used which is one-half the counts of the reed, the half distance between the marks being judged by the eye in indicating the shape of a groove. The circular lines may be marked to within about $\frac{1}{2}$ inch from the edge of the wheel, and another line is then marked about $\frac{3}{16}$ inch from the edge to indicate the depth of the teeth. The circumference is next divided into as many equal parts as the number of teeth required, each tooth representing two picks, and straight lines are drawn from the divisions to the centre of the wheel. The teeth are then cut the required depth with the edges in line with the radial lines. Each engagement of the turning catch brings a radial line in a horizontal plane with the centre of the wheel, and the centre of a peck moves upon this line.

Methods of Indicating Lappet Designs.—In very many cases the wheel cutter is simply provided with a sketch of the figure that it is desired to produce, and he prepares the plan from which the wheel is cut. In constructing a plan for the wheel-cutting squared paper may be used with advantage; and in order that comparisons may be made, different methods of representing a figure are shown in Fig. 321, in which each plan corresponds with the pattern given in Fig. 320. The design repeats on 50 ends and 42

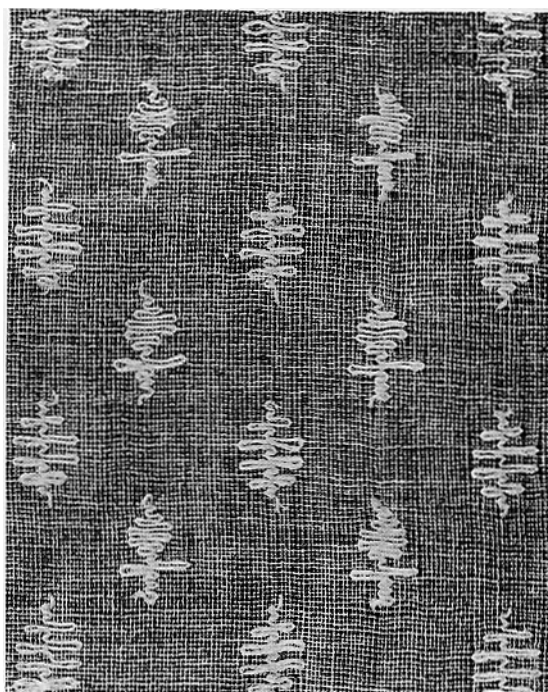
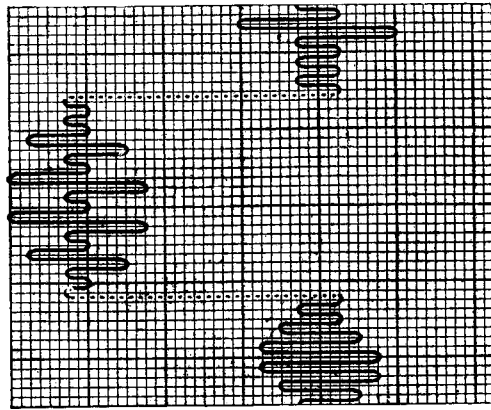

Fig. 320.

picks, or 25 splits of the reed, and 21 teeth of the wheel, and the differently shaped figures, arranged in alternate order, are formed by one needle bar. A in Fig. 321 shows exactly how the whip threads are traversed in the cloth as viewed from the wrong side, each vertical space representing an end, and each horizontal line a pick. The dotted lines show the portion of thread which is cut away after the cloth is woven, leaving the figures quite detached from each other. If the counts of the design paper is suitable for the proportion of ends and picks in the cloth, this method gives an accurate representation of the effect; but it is not convenient for the wheel cutter, since two vertical spaces correspond with one split of the reed, or one circular space of the wheel. By using paper in which each large square is divided into spaces in the same proportion as the splits per inch are to the picks per inch—as, for example, for a square cloth

into 4 spaces vertically, and 8 spaces horizontally—a convenient representation of the design may be made. Thus, B in Fig. 321 shows the design A worked out on 4×8 paper, each vertical space of which represents a concentric space in the wheel and each horizontal line a pick. The full width of the repeat is not shown in this plan, as the wheel cutter is concerned only with the space over which a thread is required to be traversed. The accurate repetition of the figure in width is dependent upon the spacing of the needles in the bar. In the method shown



A

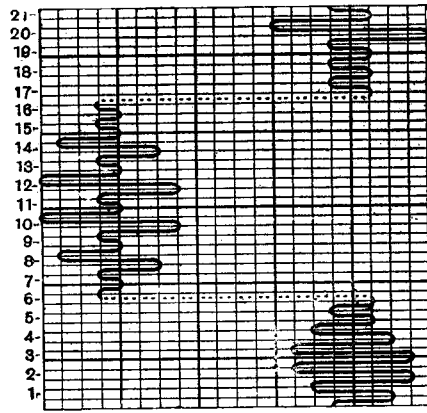

B

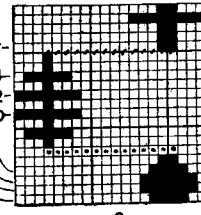

C

Fig. 321.

at B the outline of a figure may be first drawn to scale on the paper in the ordinary manner, and then the required moves be indicated, as represented in the example.

A reduced method of indicating a wheel-cutting plan is shown at C in Fig. 321, in which each vertical space represents a concentric space, and each horizontal space a tooth of the wheel. It will be noticed that C consists simply of the numbered spaces of B, and shows exactly how the groove will require to be cut. A design is shown in proper proportion, and is more readily marked in, but the moves are more difficult to follow than in the system shown at B; but if it is thoroughly understood that the marks, taken horizontally on each space, represent the distance traversed by the peck in one of its movements, say from

right to left, the method is quite appropriate for the simpler styles of figures.

Method of Indicating a Pattern Groove.—A system of indicating the edges of a pattern groove is illustrated in Fig. 322. The example corresponds with the effect represented in Figs. 320 and 321, and the marking of the groove will be readily followed by comparing it with either B or C in Fig. 321. The arrangement is for a left-hand loom, and the full repeat of the design is represented on one-half of the wheel. The moves to the left in B, Fig. 321, are numbered to correspond with the similarly numbered radial lines of the wheel, and the first vertical space in the plans B and C coincides with the first concentric space in

Fig. 322. Commencing with the position marked 10, where the whip thread is at its farthest point to the left, the outer edge of the groove is marked on the first concentric line. At 11, the edge is marked on the fourth line, or three spaces inward, at 12 on the first, at 13 on the fourth, at 14 on the second, at 15 and 16 on the fourth, and at 17—where the groove changes position for the commencement of the other figure—on the fourth, and also on the sixteenth line, or 15 spaces inward. The position of the outer edge is thus indicated, where the concentric lines cross the radial lines, until the complete circle of the wheel has been made.

In marking the position of the inner edge, it is first necessary to find the width of the groove at one position, by adding the number of spaces which the diameter of the peck is equal to, to the number of spaces traversed by the peck at this point. If the diameter of the peck is $\frac{1}{4}$ inch, with 32 spaces per inch, 8 spaces are added to the traverse; with 20 spaces per inch, 5 spaces, and so on. (Sometimes the bent end of the peck is made smaller by filing it, or larger by beating it flatter, in order to adapt it to a fraction of a space, or to slightly increase or decrease the traverse in a given groove.) In Fig. 322 4 spaces are allowed for the diameter of the peck, and commencing with the position marked 10, it will be

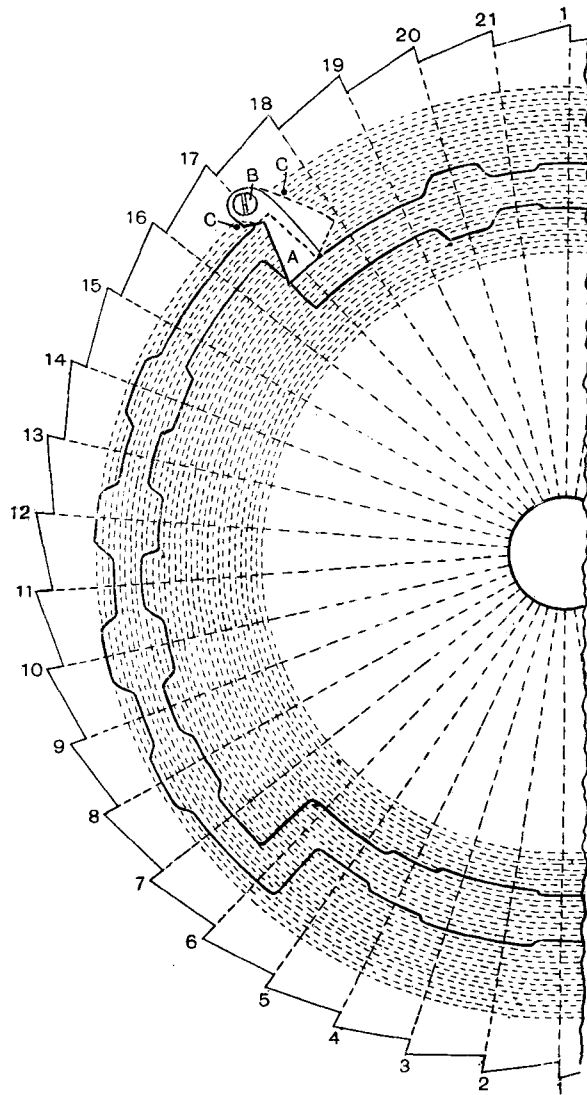

Fig. 322.

noted that the traverse is 7 spaces; therefore the inner edge of the groove at this point is $4 + 7 = 11$ spaces distant from the outer edge. When one position has thus been found on a radial line, the concentric lines are successively marked in the manner described in reference to the outer edge. When the lines of the

groove have been completed, the wood between them is carefully bored out to the required depth—say $\frac{3}{8}$ inch.

In an ordinary groove two concentric lines are sloped towards each other intermediate between two radial lines, but when the groove changes abruptly towards the centre of the wheel, as shown on the radial line numbered 17 in Fig. 322, the peck is liable to catch against the approaching edge of the groove as the wheel revolves. This will be understood if the moves of the peck, in relation to the turning of the wheel, are followed. Thus, taking the radial line 16, the peck moves from the inner to the outer edge of the groove, then the wheel turns, and while this is taking place the peck is really in easy contact with the outer edge. After the rotation of the wheel the peck moves on the line 17 against the inner edge, then it moves back on the line 17, and this is followed by another rotation of the wheel. If allowed to pass the corner of the outer edge in moving back, the peck would lock the wheel, and in order to avoid this a small catch A, centred freely at B, is provided. When the peck is moving on the line 17 from the outer to the inner edge of the groove, it pushes up the catch A to the position shown by the dotted lines; but when the return movement takes place the catch has dropped and the peck moves against its edge. The catch is shaped in conformity with the edge of the groove, and two pins C are driven into the wheel to limit the extent of its movement.

There is a similar abrupt change in the position of the groove on the radial line 6, but as the move is away from the centre of the wheel no catch A is necessary. Thus, on the radial line 5 the peck moves from the inside to the outside of the groove; the wheel turns, and the peck moves against the inside on the line 6, then on the same line against the outside, and while it is in this position the wheel turns again. The catch A requires to be placed on the side of the groove that the peck is in contact with when the wheel commences to turn. Thus, in the case of adapting the wheel represented in Fig. 322 to a right-hand loom, it would be necessary to change the position of the catch to the inside of the groove.

A feature to note in Figs. 319 to 322 is that each design repeats on an odd number of teeth of the wheel. This is frequently necessary when a perfectly balanced or symmetrical effect is required. Thus, in Fig. 319, in order that both turning points of the waved line will be exactly the same, it is necessary for the half repeat to be made on an odd number of picks, while in Fig. 321, in obtaining the moves from one spot to the other without the needle bar dropping, it is necessary for an odd number of picks to be employed for each figure. An even number of teeth could be employed for a style such as the latter by making one figure 2, or 6, etc., picks longer than the other.

Continuous Two-frame Lappet Design.—The pattern in Fig. 323 shows a style of ornament produced by two frames working in combination, which are continuously in action. The corresponding plan is given at A in Fig. 324, as viewed from the wrong side of the cloth, the vertical spaces representing the splits of the reed, and the horizontal lines the picks. The repeat is on 32 splits, and 70 picks, or 35 teeth an odd number of the latter being arranged for on account of the figure being symmetrical. The full squares show the moves of the first needle bar, and the dots of the second, while the circles indicate the moves of both bars. The marks on the odd horizontal spaces represent the moves from right to left, which decide the widths of the grooves. There are three features to note in this example. (1) Where two whip threads unite to form a solid portion of figure it is necessary for

the traverses to overlap. If the threads approach each other without overlapping, the side pull in opposite directions is liable to distort the ground ends unduly, and make an open space between the two portions of the figure. In obtaining the overlap the needles do not cross each other, as both bars move in the same direction. (2) It is necessary for the distance from centre to centre of the needles in each bar to be exactly the same as the space occupied by the number of splits in the repeat. (The spacing of the needles is considered more fully in reference to a subsequent example, p. 319.) (3) The different bars require to be set so that the needles are in correct relation with each other.

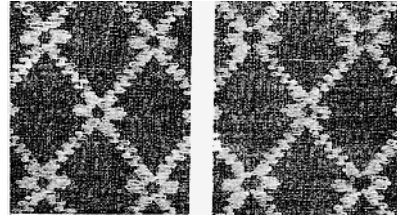

Fig. 323.

Fig. 323 illustrates good and bad setting, the pattern on the right showing the whip threads overlapping more in one central figure than in the other, while in that on the left the overlap is equal, and a perfectly symmetrical figure results.

Relative Positions of the Needle Bars and Pecks.—Although the traverses of the whip threads may require to overlap in the cloth, as in the example given in Fig. 323, in the wheel it is necessary for some thickness of wood to separate

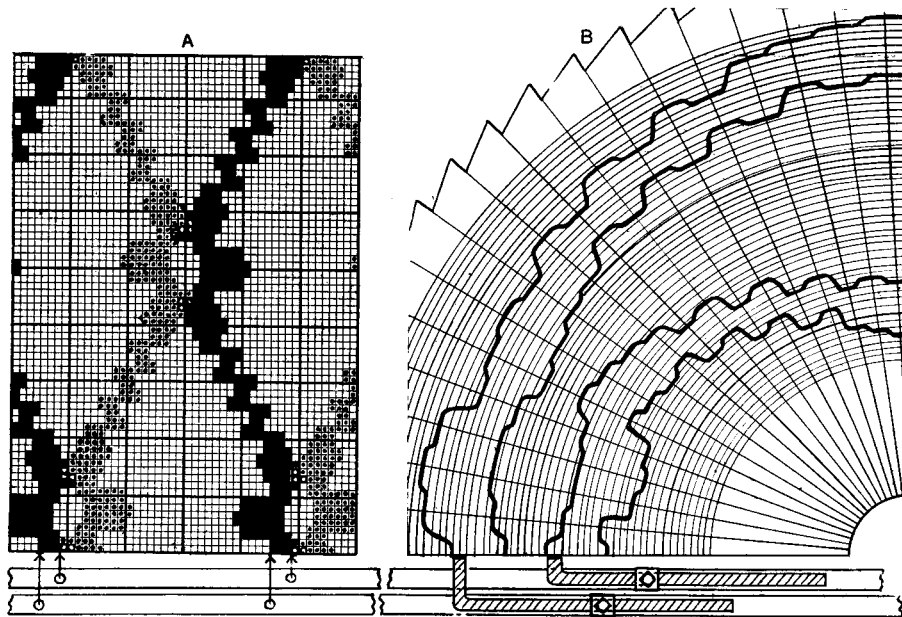

Fig. 324.

the grooves at every point; therefore the relative position of the pecks is not the same as that of the needles in the bars. This is illustrated in the lower portion of Fig. 324, where the pecks are represented as being against the outer edges of the grooves, while the corresponding positions of the needles are indicated by

the arrows at the completion of the first traverse to the left. The needles are only three spaces distant from each other, compared with 13 spaces from centre to centre of the pecks. When a new design is introduced, repeated adjustments are made by releasing the screws which secure the pecks and moving the shifter frames until the needles in the respective bars are in the correct relative position for producing the desired effect in conjunction with each other.

Intermittent Three-frame Lappet Style.—Fig. 325 shows a detached spot pattern in which the figure is due to three needle bars working in unison. Fig. 326 shows how the whip threads are traversed in each figure, in this case as viewed from the face side of the cloth, the vertical spaces representing the splits of the reed, and the horizontal lines the picks. The counts of the paper is 4×6 , and is approximately in proportion to the 34 splits, and 56 picks per inch of the cloth. The centre of the figure, which is formed by a differently coloured thread, is indicated by shaded lines in Fig. 326, and it will be noted that very short traverses of the

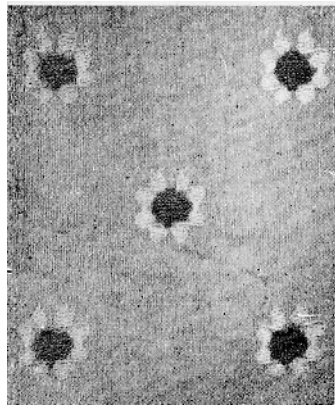

Fig. 325.

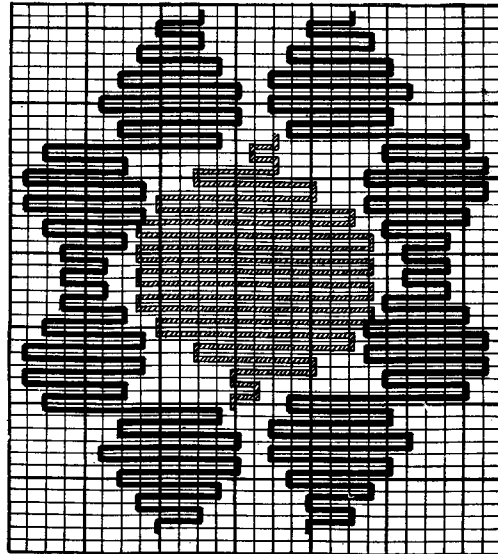

Fig. 326.

thread are made at the beginning and finish of the spot. It is customary to do this in the case of detached spots in which the floats are somewhat long, in order to prevent the threads from being plucked out during the shearing operation, and from fraying out during wear. With this provision longer floats may, as a general rule, be employed in lappet styles than in ordinary figuring, on account of the manner in which the whip threads are stitched in, and because there is a firm texture underneath the floats.

A representation of the wheel for producing the pattern in Fig. 325 is given in Fig. 327, the 6 thick lines showing the edges of the three grooves. For convenience of space, however, vertical and horizontal lines are used to represent respectively the concentric and radial lines of the wheel, while the diameter of the peck is taken as being equal to four splits of the reed. The arrangement is for a right-hand loom, with the rotation of the wheel coinciding with the move-

ment of the pecks from left to right; and where figure is formed thicker lines are marked within the grooves to show the traverses of the threads. The illustration does not, of course, give an accurate idea of the area that a peck has to work in, as the horizontal spaces are much less in proportion to the vertical spaces than the radial spaces of a wheel are to the concentric spaces. In marking the grooves it has been taken into account that Fig. 326 shows the traverses of the threads on the face side of the cloth. If a figure is required to be inclined in one direction on the right side of the cloth, it is necessary for the groove to be cut to turn it in the opposite direction during weaving; and although not necessary in this case, on account of the figure being practically symmetrical, Fig. 327 is arranged to illustrate the principle of turning a figure over. Thus, the portion of the figure on the left of Fig. 326 corresponds with the groove on the right of Fig. 327, and the move to the right with the move to the left, and *vice versa*.

All the bars are out of action on the picks between the spots, the two which form the outer portions of the figures being active for 42 picks, and inactive for 42, while that which forms the central portion is active for 22 picks and inactive for 62. The bars, whose active and inactive periods coincide, can be operated from the same ring groove at the back of the wheel; therefore, for the three bars two sets of curved metal

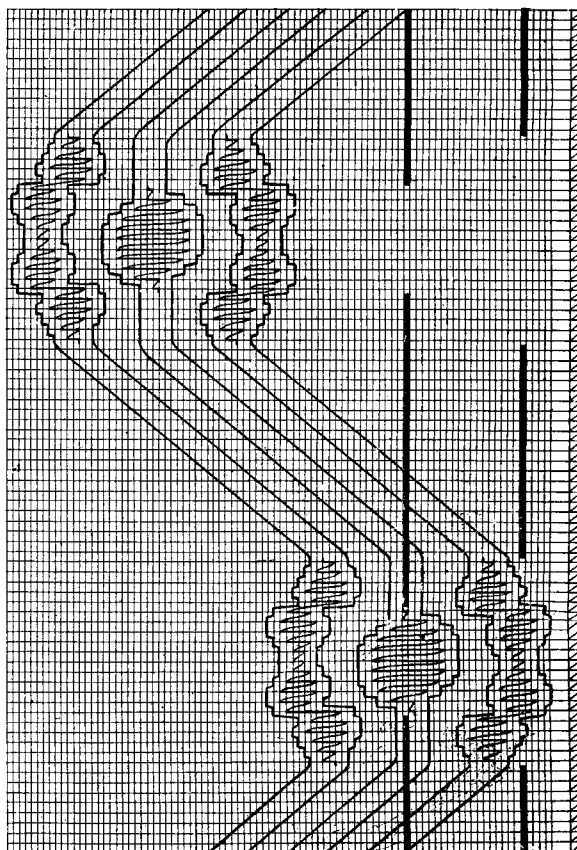

Fig. 327.

pieces in separate ring grooves and two hooked levers will be required. The solid black vertical lines in Fig. 327 show the periods during which the bars will remain out of action, the number of horizontal lines which each covers representing the number of radial lines which will be covered by the corresponding curved metal piece. It will be noted that each terminates about midway between two teeth. Between the figure portions, the grooves are made wide enough to give free movement to the pecks.

In a drop pattern of this type it is necessary for the figures to be placed

at equal distances apart. So far as regards the cutting of the wheel, therefore, it is necessary for the position of a groove of one figure to be half the total number of radial spaces distant from the corresponding position of the groove of the other figure. The distance from centre to centre of the needles in each bar can be obtained by noting on the wheel the concentric width between two corresponding positions of a groove. Thus, in Fig. 327 the number of vertical (representing concentric) spaces that the grooves move inward from the first to the second figure is 42, therefore the number of splits of the reed that the needles in each bar will require to be apart is twice this number—viz., 84.

Continuous All-over Three-frame Lappet Design.—The pattern given in Fig. 328 illustrates the production of a floral style by means of three needle bars working in combination, each of which is



Fig. 328.

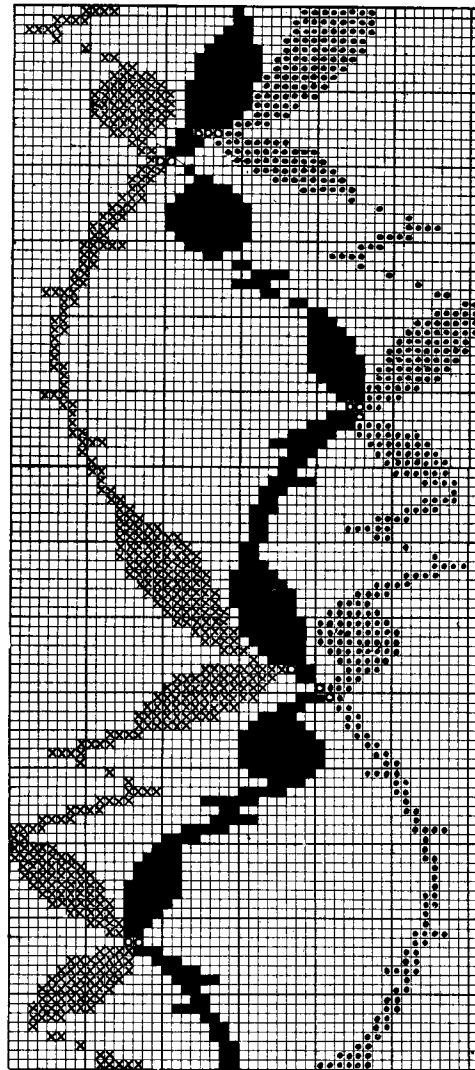

Fig. 329.

continuously in action. The corresponding plan, as viewed from the face side of the cloth, is shown in Fig. 329, the vertical and horizontal spaces in which coincide respectively with the splits of the reed and the teeth of the wheel. Different marks are used to represent the traverses of the different bars, while

the circles show where the working of two bars coincides. The marks, taken horizontally, represent the number of splits traversed by the threads from left to right, on the face side of the cloth; and the diameter of the peck, added to the spaces marked, gives the widths of the respective grooves. Although the traverses overlap in certain places, the needle bars never cross each other. The example is illustrative, in particular, of how one thread may be used to form a portion of a figure, which is then continued by the working of another thread while the first thread is forming another portion. It will be noted that the repeat is on an odd number of horizontal spaces—viz., 113. The pattern is a half-drop style, and an odd number of teeth is necessary in getting the traverses exactly the same in both halves, the pattern being turned on the half of a tooth. The marks in the upper half of the plan are not the same as in the lower half, although the figure is the same; the grooves, which produce similar parts of the design, requiring to be different in width because the figure is turned in opposite directions in the two halves. The design repeats on 48 splits, and the needles in each bar will, therefore, require to be placed exactly 48 splits from centre to centre, although the threads are actually traversed over 49 splits, one split being allowed for overlap in order to give an all-over appearance to the design across the cloth.

Crossing the Needle Bars.—The pattern shown in Fig. 330 results from four needle bars working in unison, each of which is continuously in action. The corresponding plan is given at A in Fig. 331, as viewed from the face side of the cloth, different marks being used to represent the working of the different bars, and circles to show where two bars coincide. The marks on each horizontal space represent the distance traversed by the threads from left to right on the face side, or from right to left as the cloth is woven. A special feature of the example is the crossing of the needle bars, the first and second crossing each other, and the third and fourth. It is usual in such a case to draw the whip threads between the heald cords and under the reed casing in the ordinary manner. When in the crossed position, a thread is at an angle from the needle eye of one bar to the opposite side of a needle in the other bar. This is illustrated at B in Fig. 331, which represents the positions of the needles in bars 1 and 2 when raised after the first move to the right. The arrows indicate the direction of the threads after passing under the reed, while the crosses show where the threads are attached to the cloth previous to the move. No special difficulty is caused by the crossing of the threads, except that extra care is necessary in adjusting the tension, and, on account of the greater strain, breakages are more frequent, necessitating the use of a superior quality of whip yarn. It should be noted in this example that there would have been no necessity for the crossing of the threads if they had all been of the same colour. In that case each thread would have formed the figure in a straight line of the cloth, simply overlapping where the figures intersect and then turning back in the manner represented in Fig. 329.

C in Fig. 331 shows the marking of the grooves for producing the lower portion of A wrong side up—that is, with the design turned over, as indicated by the numbers below A and C. In C each vertical space corresponds with a concentric space of the wheel, and with a vertical space of A; while each horizontal line coincides with a radial line of the wheel and a horizontal space of A. The traverses of the threads are indicated within the grooves, which are numbered as for a.

left-hand loom; and the latter are so arranged in relation to the design that the crossing of the bars 1 and 2 alternates with the crossing of the bars 3 and 4, thus equalising the strain. This is better than having all the bars crossing at one period, and then all working in the straight position at another period, which would be the case if the grooves for the first and second threads were transposed.

To find the Diameter of a Wheel—The repeat of the design given in Fig. 331 is on 138 picks and 168 ends, or 69 teeth of the wheel and 84 splits of the reed. The needles in each bar will, therefore, require to be placed exactly 84 splits of the reed from centre to centre. The threads are actually traversed over 87 splits, and rather more than the full width of the design is given at A in Fig. 331, in order to show where repetition occurs. The grooves of the wheel, however, require to occupy very many more concentric spaces than 87, because at every point it is essential for them to be kept some distance apart; while in each groove it is necessary

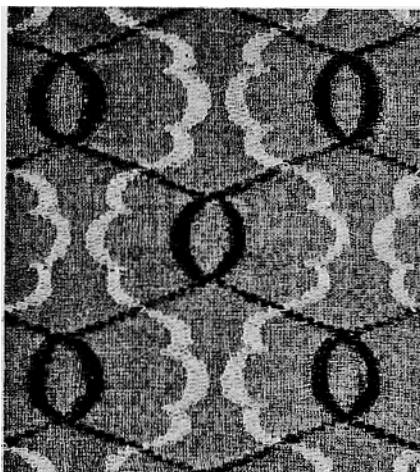

Fig. 330.

for an allowance to be made for the diameter of the peck. This is illustrated at C, in Fig. 331, in which 10 spaces are allowed for the width between the grooves where they are nearest in contact, and 6 spaces for the peck. With these allowances the total number of concentric spaces occupied by the grooves is 182, which, with 24 splits per inch, gives $7\frac{1}{2}$ inches of concentric width of the wheel, compared with $3\frac{1}{2}$ inches which the repeat of the design occupies. It should be noted that each vertical space in C, although only shown half the width, represents the same width as a vertical space in A.

It will be evident from the foregoing that the number of teeth (or number of picks in the repeat) and the concentric width occupied by the grooves will influence the size of a wheel. A large wheel is always necessary when the number of teeth is considerable, and may also be required for a small number of picks in the repeat if the grooves occupy a large space. A peck should not approach nearer the centre of a wheel than where the space between two radial lines is equal to its diameter, and if the changes in the innermost groove are abrupt, not so near, while a small space must separate the outer groove from the edge. It is usual for the grooves to be cut as far from the centre as the size of a wheel will permit, as this gives more play for the pecks, and greater certainty of action. Assuming, for the purpose of comparison, that the pecks are $\frac{1}{4}$ inch diameter, and the radius of a wheel is 12 inches, which is about the usual maximum; with the teeth $\frac{1}{2}$ inch pitch there will be 150 teeth to the round, and $\frac{1}{4}$ inch of space between the radial lines at 6 inches from the centre. A pitch of $\frac{3}{4}$ inch, on the other hand, will give only 100 teeth to the round, but there will be $\frac{1}{4}$ inch of space between the radial lines at 4 inches from the centre, the concentric width available in the latter case thus being 2 inches

greater than in the former. Assuming, further, that in the latter case $\frac{1}{2}$ inch of space is allowed at the outer edge, and $4\frac{1}{2}$ inches at the centre, the space available for the grooves will be $12 - (\frac{1}{2} + 4\frac{1}{2}) = 7$ inches.

In deciding upon the size of wheel for a given pattern it is therefore necessary to take into account that a smaller diameter reduces the space available for the grooves in two ways: (1) because the radius is smaller, and (2) because the

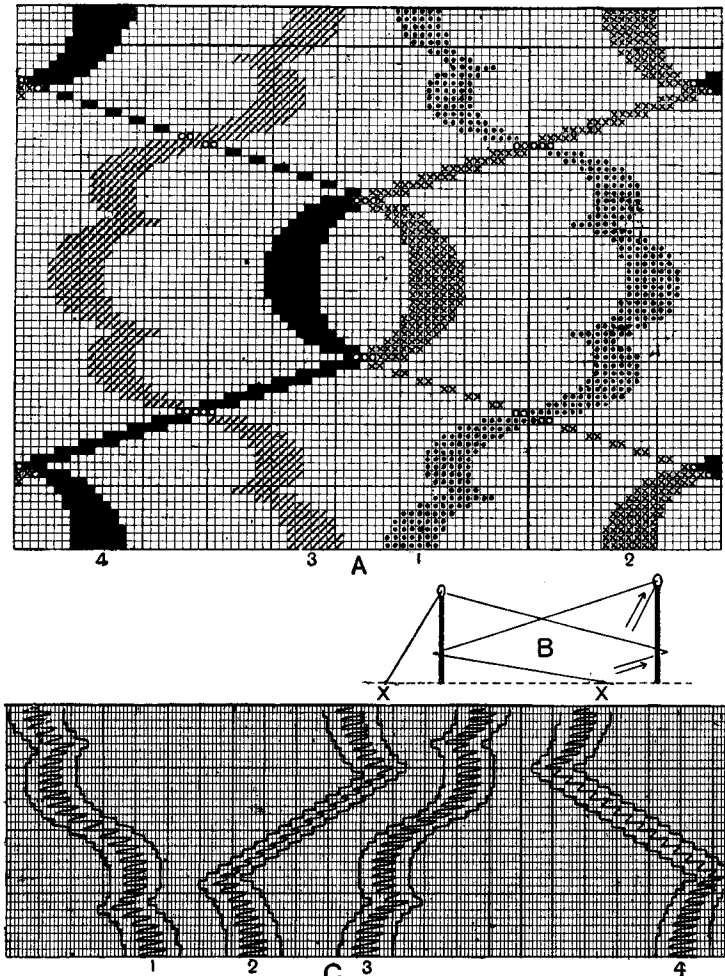

Fig. 331.

consequent reduction in the pitch of the teeth decreases the space between the radial lines, and thus increases the limit as to distance that the innermost groove may approach to the centre. Taking Fig. 331 as an illustration, with the diameter of the peck $\frac{1}{4}$ inch, the following method may be employed in ascertaining the size of a wheel for a design. The distance from the centre of the wheel, where the space between the radial lines is equal to the diameter of the peck, is

found thus :—(69 teeth in the repeat $\times \frac{1}{4}$ inch) \div (3.1416 \times 2) = $2\frac{3}{4}$ inches.
The concentric width occupied by the grooves is $7\frac{1}{2}$ inches ; therefore, with an

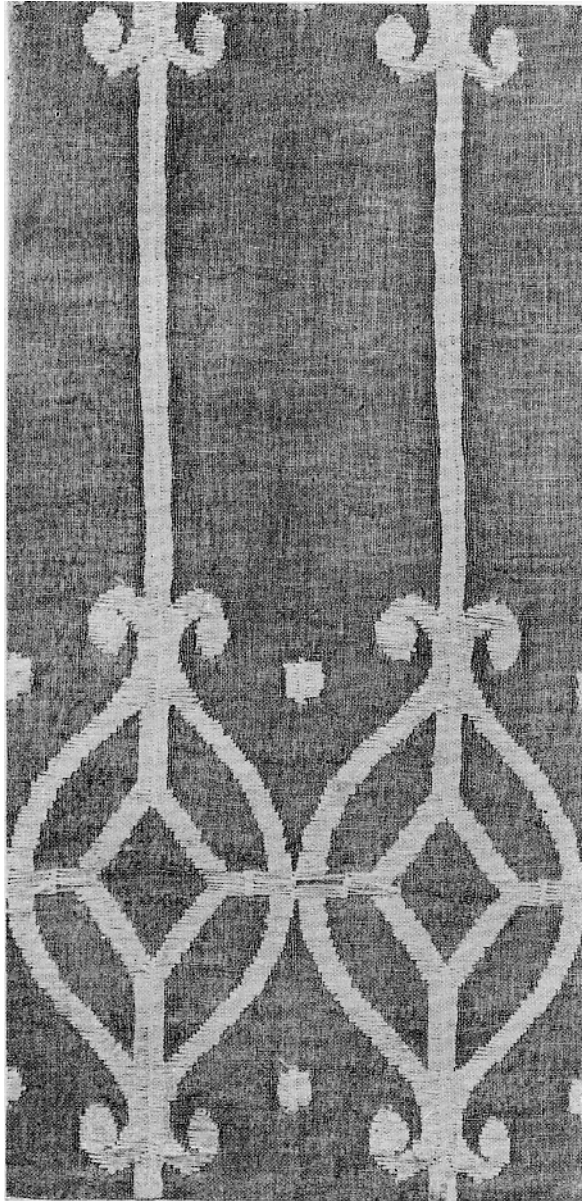

Fig. 332.

allowance of $\frac{1}{2}$ inch at the edge, the radius of the wheel will require to be at least equal to $2\frac{3}{4} + 7\frac{1}{2} + \frac{1}{2} = 10\frac{3}{4}$ inches, or $21\frac{1}{2}$ inches in diameter. Better results, however, will be obtained by increasing the distance from the centre to the innermost groove, and a wheel of 23 inches diameter may, therefore, be used, which will give approximately 1 inch as the pitch of the teeth. In the cloth the repeat in width of a design may be greater or less than the width occupied by the grooves, according to the way in which the needles are spaced, and to how the different bars are placed in relation to each other.

In deciding upon the concentric width which any one groove may occupy, it is necessary to take into account the length of the slots in which the vertical slides (W in Fig. 318) attached to a shifter frame move. It has previously been stated that the usual length of slot permits each bar to be traversed over a width of $3\frac{3}{4}$ inches, to which may be added the diameter of the peck in finding the maximum concentric space which may be occupied by the groove. In the case of a detached spot pattern in which the figures are distributed alternately, and assuming that the spot is

$\frac{3}{4}$ inch wide, the repeat in width of the design cannot exceed $(3\frac{3}{4} - \frac{3}{4}) \times 2 = 6$ inches.

The Length of Repeat.—The maximum number of picks in a design is usually from 320 to 350, but an exceptional example is given in Fig. 332, which repeats on 600 picks. The body of the figure is formed by 4 bars working in combination, and repeats on 318 picks; while the straight line portion is formed by 2 bars. The grooves for the latter portion, however, are only cut for a short distance, as while this is being formed the rotation of the wheel is stopped. In another method of obtaining a very long repeat from a wheel of ordinary size, the bowl, which operates the turning of the wheel, is moved laterally and thrown out of action on alternate revolutions of the low shaft. The wheel is thus rotated only once in every four picks; hence the repeat extends over four times as many picks as there are teeth in the wheel, but the method has the effect of making the figure coarser in outline.

Methods of Diversifying Lappet Designs.—In addition to the origination of new figures there are several methods of producing diversity of design in lappet styles, as, for example, by variously colouring the whip threads; by varying the spacing of the needles in the bars; by changing the position of one bar in relation to another; by leaving a proportion of the bars out of action; and by varying the interweaving of the ground ends; while two or more of the methods may be employed in combination. For example, assuming that three grooves are cut in a lappet wheel to produce the three systems of traversing shown at A in Fig. 333, the designs given at B, C, and D, and many others, may be readily produced from the same wheel. The spacing of the needles is indicated below B, C, and D by the arrows, which are shown of different lengths to correspond with the position of the respective bars. B shows an effect which can be formed by spacing the needles the same in each bar, one needle being required in each for every repeat. The shifter frames and pecks will, of course, require to be so adjusted that the all-over design will result by the three bars working in combination. C shows a change of effect due solely to varying the positions of the needles, the bars being in exactly the same relation to each other as in B. The change of effect from C to D, however, is due not only to a variation in the spacing of the needles, but in addition the relative position of the bars will require to be changed; while the example is also illustrative of a scheme of applying differently coloured threads.

Spacing the Needles in the Bars.—The correct spacing of the needles is of the greatest importance; and a method of marking the bars to show where the needles require to be driven in for the design D is illustrated at E, F, G, and H in Fig. 333. Only rather more than one repeat of the pattern is shown; but in practice, in order to reduce the liability of error, it is customary first to measure off, by means of a reed scale and dividers, the width of several repeats. The spaces are indicated on a bar over the desired width, and then each space is divided up into the required number of parts. If more than one needle bar is employed, in order to ensure that all are equally accurate the spacing of all the needles is marked, as represented at E, on a separate piece of wood, termed a "pattern stick," which is rather longer than the width of the warp in the reed. The number of the bar is indicated against each mark upon E, and the piece of wood and the bars are placed together; then with the aid of a set-square the marks are indicated on the

respective bars in turn, as shown at F, G, and H. The punches used in driving

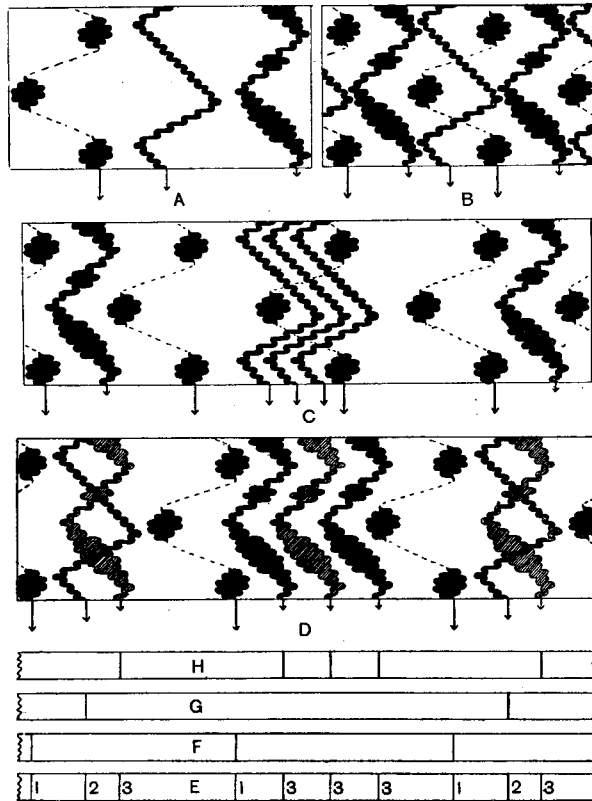

Fig. 333.

in the needles are shaped so as to prevent the points from being damaged, and the lower end forms a projection which enables a needle to be driven in a vertical direction for the exact distance required; different punches being employed for the different lengths. After the needles have been driven in they are bent back, those in the rear bar being inclined until the points are directly above the edge of the bar, while those in the other bars are successively bent back a slightly greater distance. Afterwards the spacing of the needles is again adjusted, but this time each bar is laid flat in a suitable position in relation to the pattern stick, and the needles are, if necessary, bent to right or to left until their points are in exactly the proper position.

PRESSER WHEEL SYSTEM

The presser wheel system is different from the common wheel system in that the wheel is rotated one tooth at every pick, and a peck is made to press continuously against the outer edge of the groove, which is the only side of the groove that requires to be shaped according to the pattern. In keeping the pecks constantly in contact with the outer edges, the straps *u* and *v* in Fig. 318 (p. 301), and the levers *q* and *r*, are thrown out of action. On the underside of each shifter frame which is in use, and near the centre of the loom, a screw or hook is inserted to which one end of a light spiral spring is attached. The other ends of the springs are connected to a bracket which is fastened below the slay and passes under the frames. The springs are in line with the shifter frames, and the tension tends to draw the latter in the direction away from the centre of the pattern wheel; hence, as the wheel turns, there is always a certain amount of friction between the pecks, and the outer edges of the grooves. In some cases, in order to reduce the friction, larger pecks—up to $\frac{3}{4}$ inch diameter—are used; or, when very long moves are required, the bent end of a peck may consist of a specially shaped spindle upon

which a small anti-friction bowl revolves where contact takes place with the outer edge. As a rule, however, the ordinary size and form of peck is found to work quite satisfactorily, and is, therefore, most generally employed, as the use of a larger peck makes it necessary for the radial spaces and the pitch of the teeth to be greater, which increases the size of the wheel and restricts the length of the repeat. On account of a tooth being required for every pick, a presser wheel requires to be larger, and is more costly than a common wheel for the same number of picks in the repeat, nor can such long patterns be obtained. There is, however, greater scope for producing diversity of effect than with a common wheel. Patterns of a less massive or solid character may be formed, as in this case the return movement of a needle bar, on alternate picks, is not essential. Consecutive moves in the same direction can be made, and waved line effects be formed, each of which is of the same width as the thickness of a thread, as shown in Fig. 334; or the whip threads may be used to form a fine outline to a simple figure, as is represented in Fig. 335. The return

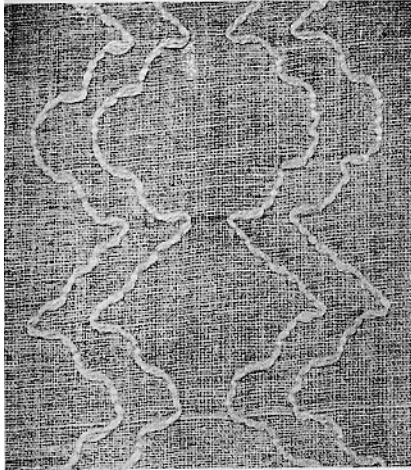

Fig. 334.

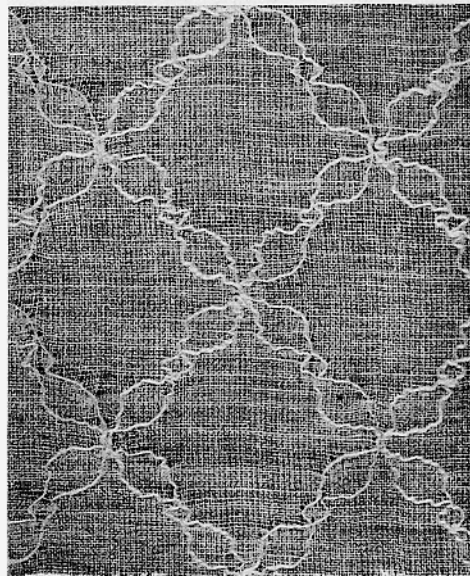

Fig. 335.

movement of the needle bars may, however, be readily arranged for, and variety of pattern be obtained by combining solid figures with line effects, as shown in Fig. 336. The traversing of the whip threads in Fig. 336 (slightly modified so as to reduce the size of the repeat) is shown in Fig. 337, in which the vertical spaces represent the splits of the reed, and the horizontal lines the picks, the repeat extending over 24 splits and 62 picks. Two needle bars are required in forming the pattern, and the traverses overlap by one split, giving the design an all-over character.

Construction of a Presser Wheel.—In constructing a presser wheel the concentric lines are marked according to the sett of the reed in the ordinary manner, but a radial line is drawn and a tooth cut for every pick in the repeat. Thus, in Fig. 338, in which the thick lines represent the shape of the grooves

for producing the effect in the lower portion of Fig. 337, the wheel, which is

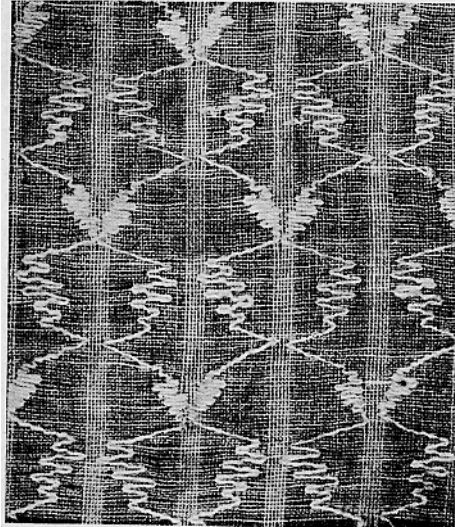

Fig. 336.

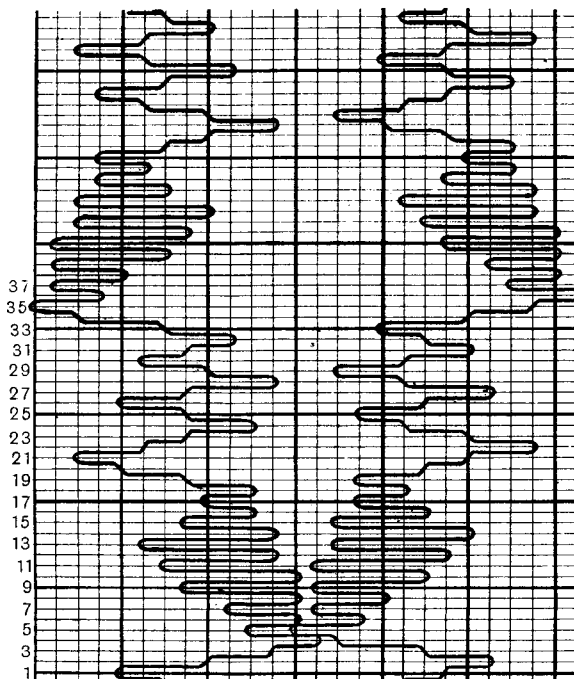

Fig. 337.

arranged for a left-hand loom, is divided into 62 radial spaces. The radial lines correspond with the horizontal lines (or picks) of the plan, and are numbered to coincide, while a concentric space corresponds with a vertical space. As a peck is constantly in contact with the outer edge of a groove, the shape of the inner edge is of little account so long as sufficient space is allowed between the edges for the free passage of the peck. Every movement of a thread requires to be marked on the outer edge. Thus, on the horizontal line numbered 17 in Fig. 337, the first thread is 8 spaces inward; therefore, on the corresponding radial line in Fig. 338 the outer edge of the first groove is marked on the eighth concentric space. On the following horizontal

lines the first thread is 10, 7, 4, 2, 5, 7, 10, etc., spaces inward in succession, and comparison will show that the outer edge of the groove is successively marked on the corresponding concentric spaces where the radial lines are intersected. The shape of the second groove is similarly indicated, care being taken in commencing that sufficient space will separate the grooves at every part.

As the wheel is turned one tooth at a time, the outer edge of each groove presses a peck to the right, or permits it to be drawn to the left, according to its shape. Between the radial lines it will be noted that the shape of the outer edge varies according to whether the movement of a peck is from

or towards the centre of the wheel. Where the traverses are from the centre (to the left in this case), the grooves are so shaped that the movement is almost instantaneous, the springs being allowed immediately to contract. On the other hand, where the traverses are towards the centre of the wheel, during which the springs are distended, the outer edges are gradually sloped, which prevents the wheel from being locked, and at the same time reduces the friction with the pecks. A disadvantage which arises from the grooves being thus shaped is that a wheel cannot be used for the opposite hand of loom to that for which it has been cut, as, if rotated in the reverse direction, it will be locked by the pecks.

In producing designs which include portions of a figure in which a whip thread is repeatedly traversed to left and right alternately (as on the picks 4 to 18, and 35 to 49, in Fig. 337), the spaces between the radial lines of the wheel are usually made alternately of different sizes in the proportion of about 3 to 2. This is illustrated in Fig. 338, in which the odd-numbered teeth are shown smaller in pitch than the even teeth; and it will be noted that in the solid portions of the figure the moves towards the centre of the wheel are arranged to coincide with the larger radial spaces. The friction with the picks is thus reduced

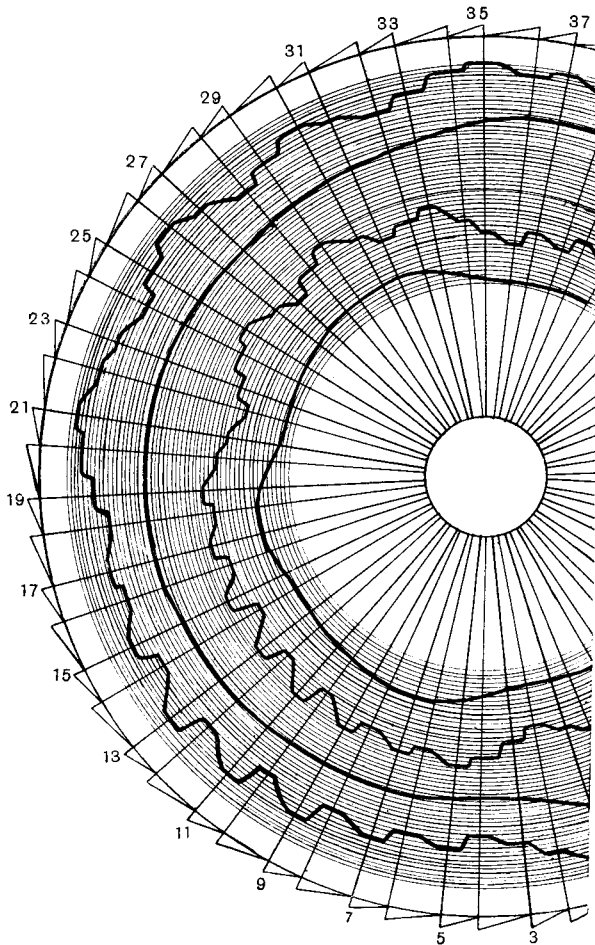

Fig. 338.

when there is most strain, as a greater space gives more latitude for gradually sloping the outer edges of the grooves, and the engaging of a larger tooth provides more time for a movement. With the arrangement of different pitches of the teeth the two bowls, carried by the low shaft gear wheel, are of different sizes to correspond, the larger bowl lifting the turning catch high enough to engage the larger teeth, and the smaller bowl, the smaller teeth; but the leverage is so arranged that the small bowl is ineffective in operating a

large tooth. If, therefore, the wheel gets an odd number of teeth out of proper rotation, it will remain stationary for a pick, and this gives the advantage that in the solid figure the to-and-fro movements of the needle bars are retained in correct time with the picking—an important point which has previously been mentioned. It is, of course, only in the parts of a design where the traverses are alternately to left and right that each movement of a bar can be definitely arranged to correspond in direction with the pick that follows. In the other parts of a pattern the direction of a traverse may or may not coincide with the direction of the following pick; and care is necessary here in arranging the moves, or undue friction may be caused. Thus, long moves may be more readily made if they correspond with the engaging of the larger teeth, and if each is in the same direction as the pick that follows.

To find the Length of Whip Warp.—A whip thread usually requires to be very much longer than the ground warp, the length of the former varying according to the average of the distance traversed at a movement; thus, in the same pattern, if the traverses of the threads vary, different lengths will be required for the different whip warps. Assuming that the average length of the traverses of a thread is 5 splits, and there are 20 splits per inch, $\frac{5}{20}$ or $\frac{1}{4}$ inch of whip warp will be required at every pick; and if 32 picks per inch are inserted, $\frac{1}{4}$ inch \times 32 = 8 inches of whip warp will be required for each inch of ground warp. Calculations may be conveniently worked by the following rule, which gives an idea of the proportional lengths of the whip and ground warps:—

$$\frac{\text{Total splits traversed in repeat} \times \text{picks per inch}}{\text{picks in repeat} \times \text{splits per inch}} =$$

number of times the whip warp is longer than the ground warp.

In finding the total number of splits traversed by a thread it is necessary to note the moves in succession and add them together—as, for example, in Fig. 337 the first eight moves of the thread on the left are 4, 3, 2, 3, 2, 3, 3, 5 splits, which, added together, total 25. By continuing in this manner it will be found that the number of splits traversed in the full repeat by the first thread = 206. The picks in the repeat = 62, and assuming that there are 24 splits and 44 picks per inch the calculation will be:—

$$\frac{206 \text{ total splits} \times 44 \text{ picks per inch}}{62 \text{ picks in repeat} \times 24 \text{ splits per inch}} = 6.09 \text{ of whip warp to 1 of ground warp.}$$

The calculation is more applicable to common wheel lappet designs than presser wheel styles, and at the best only gives approximately the length of whip warp that is required, as the length can be varied by the tension that is put upon the whip threads.

Lappet Styles in Imitation of Net Leno.—The presser wheel system is conveniently adapted to the production of such styles as are shown in Figs. 339 to 345, which are similar in appearance to effects produced on the gauze or leno principle. With the lappet wheel, however, there are no restrictions as regards the denting of the warp threads, as a whip thread, not being passed through the reed, may be readily made to cross a large number of splits, while one whip thread may cross another. Fig. 339 shows a style produced by two frames in

which two whip threads cross in opposite directions over (or under during weaving) 11 ground ends. A flat view, of a portion of the effect, is given at A in Fig. 340, the interlacing of the threads being shown as viewed from the wrong side of the cloth in order that the order of working may be more readily compared with E, Fig. 340, which represents a section of the wheel for producing the effect. In E the thick lines show the outer edges of the two grooves, and the shaded lines the approximate position of the inner edges; while the crosses indicate where the needle bars are left down or out of action. The grooves are lettered to coincide with the whip threads, and the radial lines and picks are connected by dotted lines, and are also correspondingly numbered. The whip threads work straight for 4 picks, in the crossed position for 2 picks, straight for 10 picks, crossed for 2 picks, and straight for 30 picks, of which only 6 picks are shown at A. About the centre of the straight portions the bars are left down on alternate picks, the whip threads thus being interwoven in plain order with the weft at these places. In E six concentric spaces are allowed for moving the threads the required distance; and it will be noted that when the picks 5 and 6, and 17 and 18, are inserted, the groove W will have allowed the thread W to be drawn to the left, while the groove X will have moved the thread X to the right.

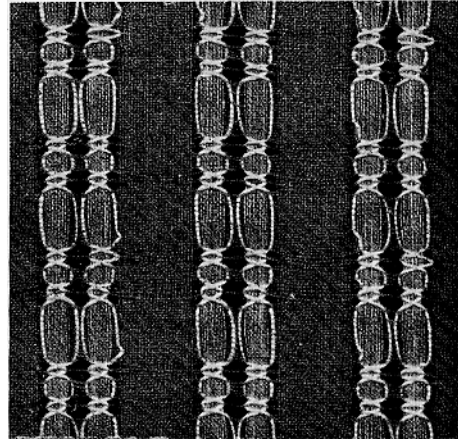

Fig. 339.

Fig. 341 shows a four-frame lappet stripe in which the threads, viewed from the wrong side of the cloth, interlace in the manner indicated at B in Fig. 342. The thick lines in F, Fig. 342, represent the form of the outer edges of the four grooves which will produce the effect, but an accurate idea of the actual space

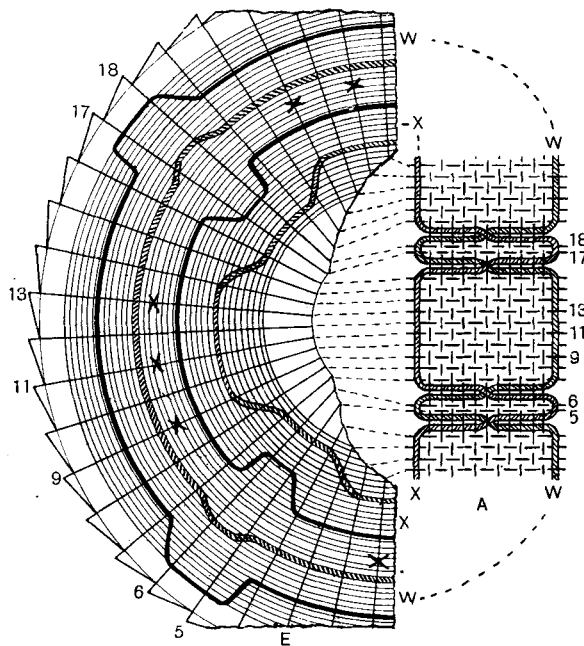

Fig. 340.

The thick lines in F, Fig. 342, represent the form of the outer edges of the four grooves which will produce the effect, but an accurate idea of the actual space

that each peck has to work in is not given, as vertical and horizontal lines are used, for convenience of space, instead of concentric and radial lines. Where a crossing takes place a whip thread is raised for three picks in succession, but in the straight portions it is raised on alternate picks only. The dots in F show on which picks the first and second bars will be left down, and the crosses the third and fourth. On the picks marked, 2, 14, 26, and 38, the groove lettered W will permit the thread

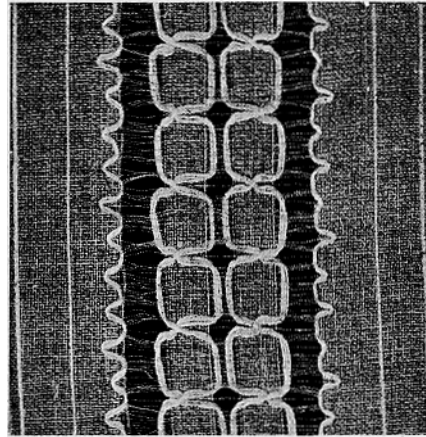

Fig. 341.

correspondingly lettered to be bound in four splits (approximately) to the left of its ordinary position; while similarly the groove X will move the whip thread on the opposite side of the stripe (not shown in B), four splits to the right. The threads Y and Z move in opposite directions from one side to the other of 19 ground ends, but two traverses are made in getting a complete movement, the whip threads being bound in about the centre of the ground ends on the picks 8 and 32. The style differs in this respect from that shown at A in Fig. 340, in which the full distance is moved in one traverse; also each thread Y and Z interweaves for an equal space first on

one side and then on the other side of the ground ends, whereas in Fig. 340 each thread W and X interweaves most of the time on one side only.

In the grooves Y and Z in F, Fig. 342, twelve spaces are allowed for moving the whip threads the distance of 19 ground ends, or about 10 splits, a larger traverse being allowed than is actually required in order that the threads will rise at each side quite clear of the ground. A number of splits of the reed are left empty between the groups of ground ends; therefore, so long as the needles rise in these places the length of the traverse is immaterial, as the tension on the whip threads draws them close against the ground stripes. The interlacing of the whip threads at the sides is clearly an imitation of doup weaving, but it will be noted that the crossing is very irregular, the thread W in Fig. 342 passing under 4, 8, 4, and 6, ground ends at successive movements. Unless there are empty splits on both sides of the ground ends which are crossed there is usually sufficient irregularity in the traverses of the whip threads in a lappet style to enable it to be distinguished from a doup effect, as in the latter whip a thread always crosses exactly the same ends.

Fig. 343 shows a style in which the whip threads do not cross, but simply approach each other and then return. The grooves for producing the effect would be similar to those represented in Figs. 340 and 342, either of which could be used to obtain a corresponding pattern by placing the needle bars in suitable relationship to each other.

The effect given in Fig. 344 is a two-frame style which is produced in a different manner from any of the others. In this case, as shown in the corresponding flat view of a portion of the stripe given at D in Fig. 345, each whip thread lettered W, during weaving, crosses from one side to the other of 11 ground ends, and is raised

over every pick of weft—6 picks on one side of the ground ends, and 6 picks on the other side. The thread lettered X, on the other hand, crosses from one side to the other of a space where there are no ground ends, and is under every pick of weft, but it will be noted that it passes over a thread W where two whip threads intersect. The corresponding grooves for producing the effect are

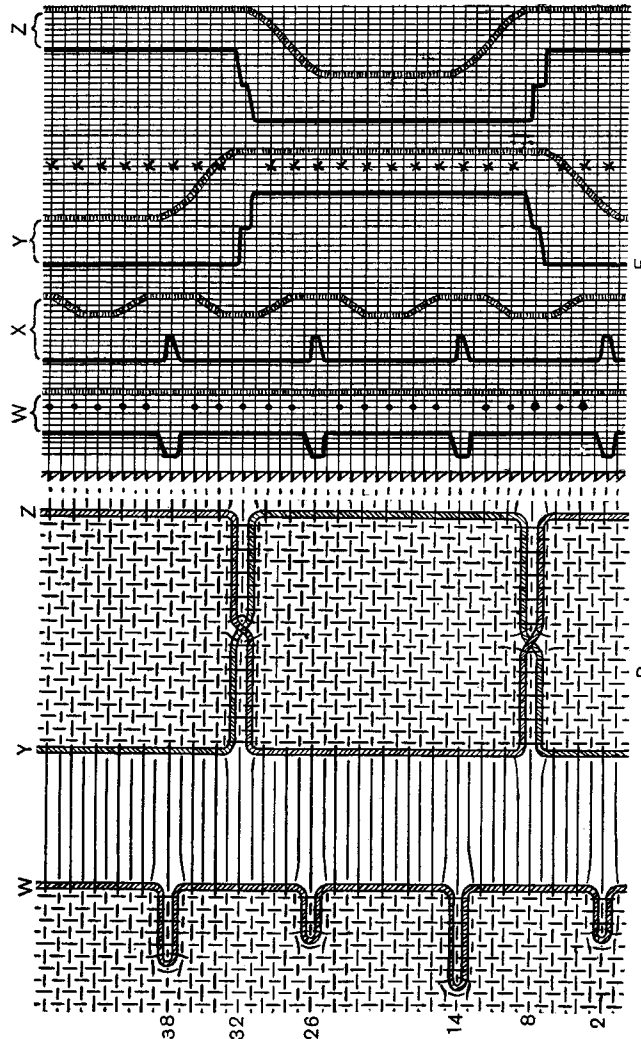

Fig. 342.

represented at G in Fig. 345, the outer edge of the groove W being arranged to move the threads W the distance of seven spaces in one direction at the same time that the groove X moves a thread X the same distance in the other direction. A feature of the style (which is more fully explained in reference to the next example) is that the threads X are never raised by the bar which carries them. Also, the two bars are set and the threads spaced in such a manner tha' when the movements

in opposite directions take place, first one and then the next thread W crosses underneath a thread X. Thus, an examination of the drawing given at D will show that on the picks numbered 1 to 6 the thread X is moved to the right, and is crossed by the second thread W which is raised on its left; while on the picks numbered 7 to 12 the thread X is moved to the left, and is crossed by the first

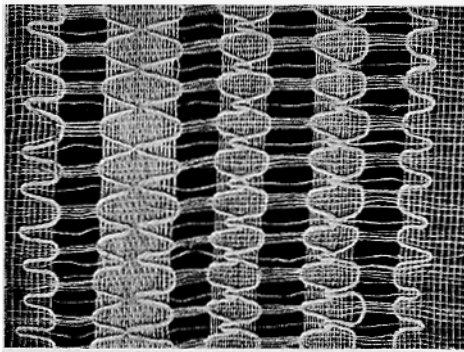

Fig. 343.

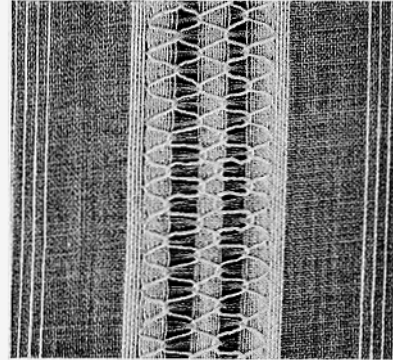

Fig. 344.

thread W which is raised on its right. Although a thread X never passes over the weft, it is intersected and bound into the cloth by two threads W alternately, and as the tension draws the latter threads in close contact with the edges of the ground stripes, the former is held first on one side and then on the other of the space between the stripes.

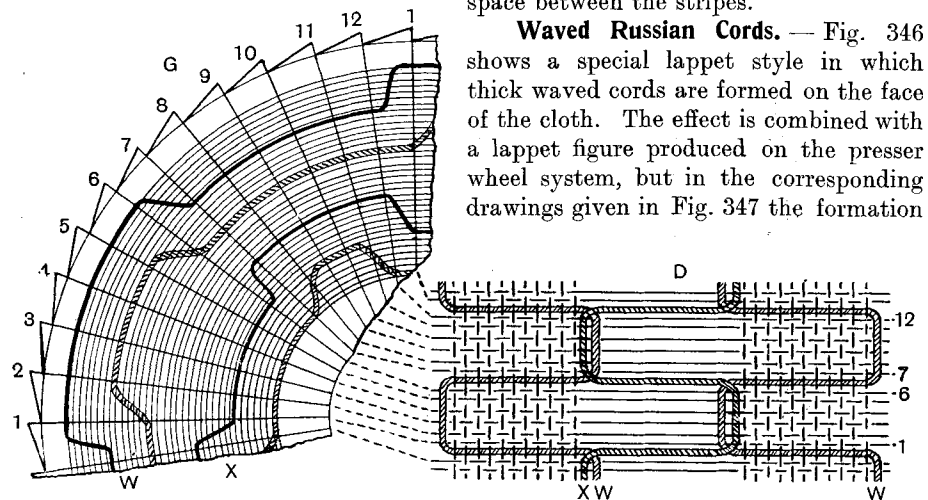

Fig. 345.

of the special cord effect only is illustrated; while for convenience of space the length of the repeat is largely reduced. In the flat view of the structure (as viewed from the wrong side), given at A, the ground ends are shown in pairs or splits working in plain order with the weft; the thick shaded line X represents a cord thread, and the solid line W a stitching or whip thread. The cord

threads are never raised over the weft, but each is bound into the cloth by a stitching thread which passes below it and is raised over every pick of weft—first on one side and then on the other side of the cord. From a cursory examination of the structure it would appear that a cord thread X is gradually moved on the underside of the cloth, according to the form of waved line required, and that a stitching thread W is similarly moved, but is also traversed from one side to the other of a cord at each pick. What actually takes place, however, is just the opposite, the bar which carries the stitching threads being simply traversed according to the form of the waved line, while that which carries the cords is given the to-and-fro traverses in addition to the waved-line movement. Thus, in A, Fig. 347, the stitch thread is raised in the third split on the picks 1, 2, and 3; in the fourth split, on the picks 4 and 5; in the fifth split, on the picks 6 and 7, etc.; while the cord thread successively occupies the position represented by the dotted lines, being moved two splits to the right and left alternately of the split in which the stitch thread is raised.

The grooves, lettered to correspond with the threads, are represented at B in Fig. 347. Usually, the arrangement for producing this style is to some extent a combination of the presser and the ordinary wheel systems. The wheel is turned one tooth at each pick, and a spring, attached to the corresponding shifter frame, keeps the peck in the groove W continuously in contact with the outer edge, as in the presser system. Both edges of each groove, however, are carefully shaped according to the pattern, and the frame which traverses the cord threads X is connected with the weighted levers (*q* and *r* in Fig. 318) as in the ordinary method; the corresponding peck thus being brought into contact first with one side and then with the other side of the groove X. In the drawing six spaces are allowed for the diameter of the pecks, the groove W being made an additional half-space wider in order to allow of a free passage, while the width of the groove X is equal to the diameter of the peck + five spaces that the cord thread is required to be traversed. The two grooves are alike except for the difference in the widths, and while in the groove W the centre of the peck will move in a line parallel with the outer edge, in the groove X the movement will be as represented by the dotted lines.

The stitching threads are carried in the ordinary manner by eyed needles fixed in a wooden bar, and the cord threads may also be similarly carried by shorter needles; but a better arrangement for the latter consists of a thin metal plate

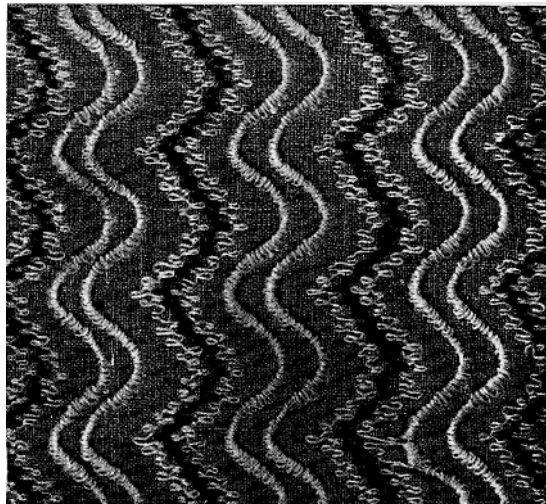

Fig. 346.

supported by the hindmost bar, which would otherwise support the needles. The metal plate may run almost the length of the reed space ; and near its upper edge it is pierced with small holes at very frequent intervals, through which, at the required places, the cord threads are drawn. The plate is about $\frac{1}{2}$ inch deep, and as it is always required to be below the lower line of the warp, its upper edge is only about $1\frac{1}{2}$ inches above the top of the bar. The stitch threads are drawn underneath the plate, so that when the transverse movements take place the cord threads

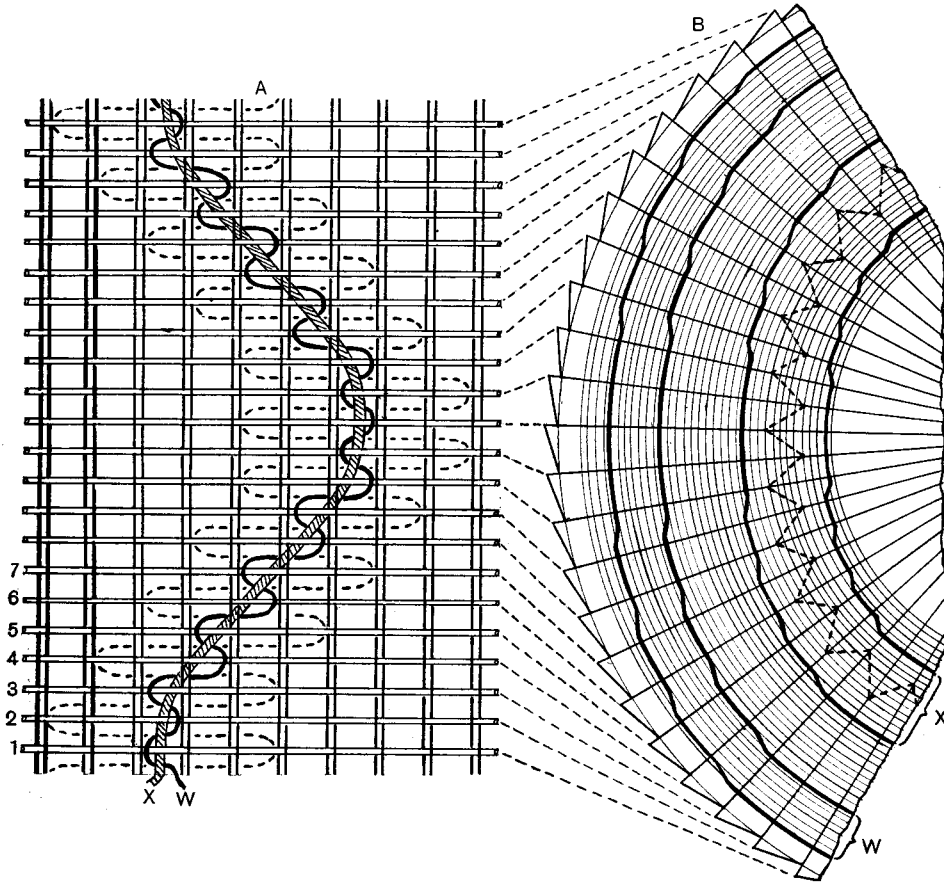

Fig. 347.

pass above them. Very accurate setting of the two series of threads is necessary, and the grooves require to be very carefully cut in relation to each other in order that a cord thread will be moved an equal distance on each side of a stitch thread, whatever the position of the latter. The prominence of the cord effect is influenced more by the tension on the stitch threads, and the extent of the to-and-fro movement, than by the thickness of the cord threads. If the wheel gets an odd number of teeth out of proper rotation, the action of the weighted levers will be incorrectly timed, which will affect the length of the traverse of the cords ; therefore, it is better for the teeth of the wheel to be alternately of different sizes, as explained

in reference to Fig. 338 (p. 323). Although the style is most generally produced on the presser-wheel principle, a common wheel can be readily arranged to give a similar result.

Imitation Lace.—A special lappet effect, which is an imitation of lacework suitable for the border of a muslin curtain, is represented in Fig. 348. The example is a two-frame common-wheel style, the pattern formed by the whip thread at each side of the stripe being produced by one frame, while the figured effect, which is formed by 15 whip threads that work differently from each other, is produced by the second. The traversing of the whip threads at the sides of the stripe is similar in principle to the foregoing examples, and, therefore, need not be dealt with here. The figure is very elaborate taking into account the means of production, and its formation is illustrative of a special principle of obtaining variety of effect in lappet work. When the traverses are to left and right alternately, a whip thread is held between the weft and the ground end that is left down nearest the inside of the extremity of a traverse; ends which are lifted having no effect in binding in a thread. It is, therefore, possible with a dobby or jacquard shedding motion to vary a design by lifting certain ground ends at some places and leaving them down at others. It is upon this principle that the style of pattern shown in Fig. 348 is produced, the variations in the lengths of the traverses to which the figure is due resulting from the method in which certain ground ends are operated.

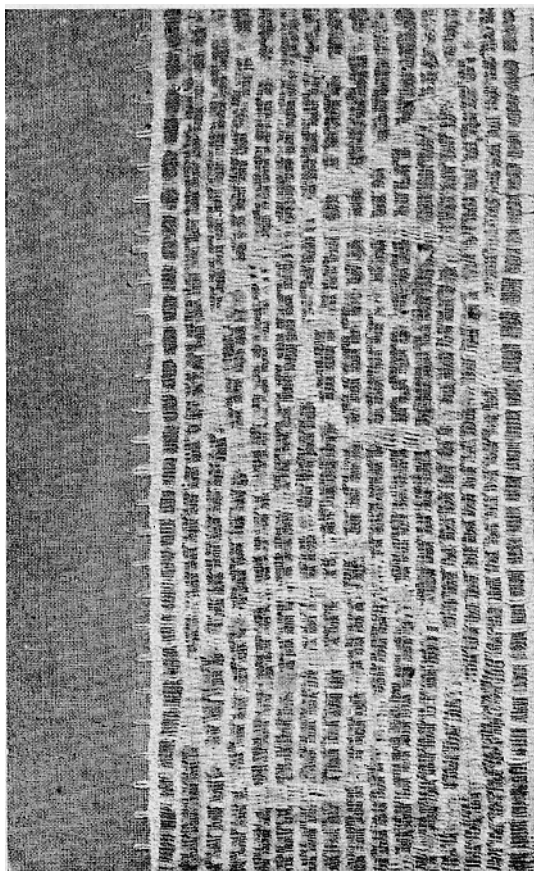

Fig. 348.

A sectional drawing showing how the figure is formed as viewed from the wrong side is given at A in Fig. 349. The ground of the cloth is arranged regularly with two ends per split, but in the figured stripe two ends, which work in perfectly plain order, alternate with a single end which is placed in one split with two empty splits at each side. The single ends do not work plain, but are operated independently, according to the effect which is required. The needle bar, which carries

all the figuring whip threads, is traversed regularly to and fro for a distance that will cause each needle to be raised first on the left of a single ground end and then on the right of the next single end, as shown at B in Fig. 349. Where a single end is left down a whip thread is held by the weft against it, and a traverse across an open space is made; but where it is raised a whip thread slides along the weft until it is against a pair of ground ends, one of which is always down. In forming the ground pattern of the stripe, the structure of which will be understood if the interlacing of the whip thread lettered C be followed, the single ends are left down only on the picks numbers 4, 9, 16, and 21. In forming the figure, the single end lettered D is down on the picks 1 to 12, and that lettered E on the picks 13 to 24, continuous traverse across the open spaces being made at these places. Thus, an opaque figure, with a very steppy outline, is formed on an open ground texture. Each single end is retained about the centre of an open space by being drawn about

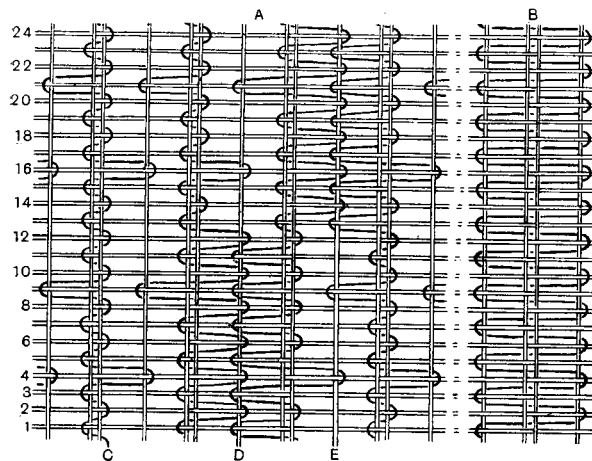

Fig. 349.

equally in opposite direction by two whip threads.

In forming the lace-like figure the needle bar simply requires to be traversed to left and to right in regular order, as illustrated by diagram B in Fig. 349. This may be accomplished by providing the proper width of slot in a *stationary* wheel, within which the peck, connected to the shifter frame, is moved to and fro. Indeed, the example illustrates a system of lappet weaving in which the wheel may be dispensed

with so long as suitable means are provided to determine the regular to-and-fro movement of the shifter frame. In the stripe shown in Fig. 348 there are 14 single ends which work differently from each other, and the ground of the cloth is plain; therefore, a shedding motion of at least 16 shafts capacity is required. The chief difficulties in producing the style are in the tensioning and creeling of the different threads, and in keeping the shedding in correct time with the to-and-fro movements of the needle bar.

Patterns produced by varying the Order of Lifting the Needle Bars.—The diagram given at C in Fig. 350 illustrates a special style of lappet ornamentation in which, as in the foregoing example, the whip threads are traversed regularly to right and left all the time. In this case, however, the whip threads are stitched on to an ordinary plain ground texture, and as many needle bars are required as there are different orders of working in the repeat of the design. The repeat of C contains ten whip threads, which, as shown by the numbers below, may be drafted on to seven bars. All the needle bars are simultaneously moved a fixed distance (four spaces in this example) from left to right and from right to left on succeeding picks,

and each whip thread is confined to a definite area in a straight line of the cloth. The vertical movement of each bar, however, is under separate control from a dobby, and by suitably pegging the lattices the whip threads are lifted into the shed opening, or are left out of action according to the effect which it is desired to produce. Leaving a bar down necessarily prevents the threads carried by it from being bound into the cloth; and it is upon the principle of thus neutralising

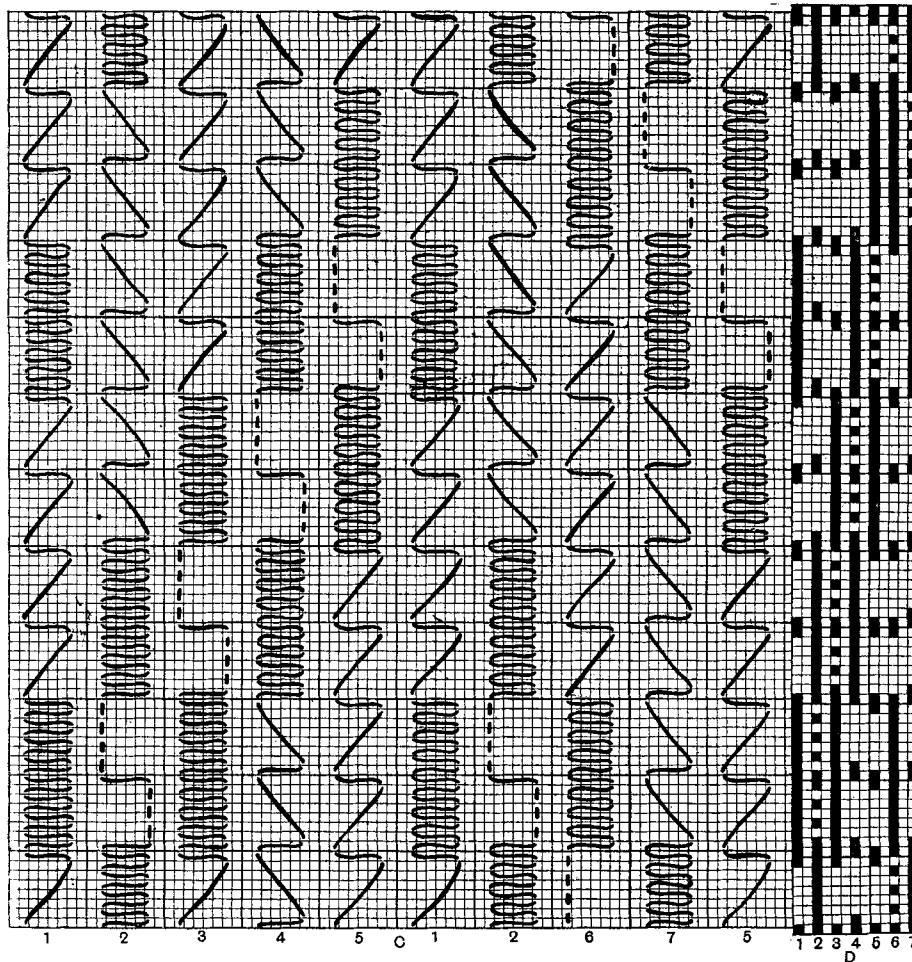

Fig. 350.

the lateral movement of the bars which regularly takes place that the style of pattern under notice is produced. In C the horizontal lines, which represent the picks, are shown passing over the whip threads where the latter are bound into the cloth—on the left on the odd picks, and on the right on the even picks. In the plan D in Fig. 350 the vertical spaces are numbered to correspond with the whip threads in C, and the marks on the squares show where the threads are bound

in—*i.e.*, where the needle bars are raised during weaving. A solid portion of whip figure is formed where a bar is lifted for a number of picks in succession, as shown by the thread 1 on the picks 8 to 25. By raising a bar on an odd pick, and leaving it out of action for a time before lifting it in on an even pick, the whip forms a diagonal line from left to right (on the face of the cloth), as shown by the thread number 1 on the picks 1 to 8. If, however, a bar is lifted on an even pick, and is then inactive before being lifted on an odd pick, a diagonal line from right to left is formed, as shown by the thread 4 on the picks 2 to 9. If a bar is lifted only on the even picks, it will form a straight line on the right, and if only on the odd picks a straight line on the left, as shown by the thread 2 on the picks 10 to 16, and 17 to 25 respectively. Each whip thread can thus be made to form two kinds of horizontal, vertical, and diagonal lines simply from the manner in which the bar is lifted. As it is only in a vertical direction that the bars require to be moved independently of each other they may be made thinner than is ordinarily the case, and a larger number can thus be placed in the space between the pin-bar and the reed. The system, combined with careful drafting of the whip threads on the bars, gives great scope for the production of comparatively elaborate effects which are different in character from the ordinary lappet styles.

Very many ingenious modifications of and additions to the Scotch lappet wheel loom have been made by different manufacturers, who purchase the loom in its standard form and adapt it to meet their special requirements.

CHAPTER XV

SWIVEL WEAVING AND DESIGNING

Purpose of Swivel Mechanism—Swivel Ornamentation and Embroidery compared—General Description of Swivel Mechanism—Relation of Pitch of Shuttles to Repeat of Jacquard. Detached Swivel Figures—Imitation Embroidery—Special Swivel Style—Figuring with two or more Swivel Wefts—Combination of Swivel and Ordinary Figures.—Production of Detached Figures in One Kind of Weft by Two Shuttles—All-over Swivel Figures. *Power Swivel Mechanisms*—All-over-Figuring Swivel Loom—Rack and Pinion Swivel Loom—Circular-Swivel Mechanism.

Purpose of Swivel Mechanism.—The term “swivel” was formerly applied to the type of loom in which several narrow fabrics, such as hat-bands, ribbons, tapes, etc., were independently formed alongside each other. In this machine a separate shuttle is employed for each fabric, but there is no fly shuttle, and the goods are now generally described as smallwares. In swivel weaving as at present understood, a number of small shuttles work in conjunction with an ordinary fly shuttle, the latter inserting a ground weft which forms with the warp a foundation cloth upon which the swivel shuttles produce figures in *extra weft*. The chief purpose of the swivel arrangement is to produce the ornament with the least possible waste of the extra yarn. Each figure, and in some cases each part of a figure, in a horizontal line of the cloth, is formed by a separate shuttle; the extra weft thus being introduced only where required, with little or no material extending between the figures on the reverse side of the cloth. In addition to the great saving of the extra, and

usually costly, figuring yarn, the swivel method has the advantage over the ordinary system of extra weft figuring that each shuttle may control a distinct colour, while the figures have a richer and fuller appearance on account of the weft being thrown more prominently on to the surface. The addition of the swivel mechanism, however, makes the loom much more complex, consequently there is reduced speed and output. The cloths are woven wrong side up, and there is, therefore, the disadvantage that defects caused by broken ends more readily escape observation; but, on the other hand, weaving the cloth right side up would necessitate the bulk of the warp being raised on the swivel picks. Compared with lappet figuring, in which the floats of a thread cannot be stitched between the extremities, swivel figuring produces much neater effects, as any form of weave development can be applied to a figure.

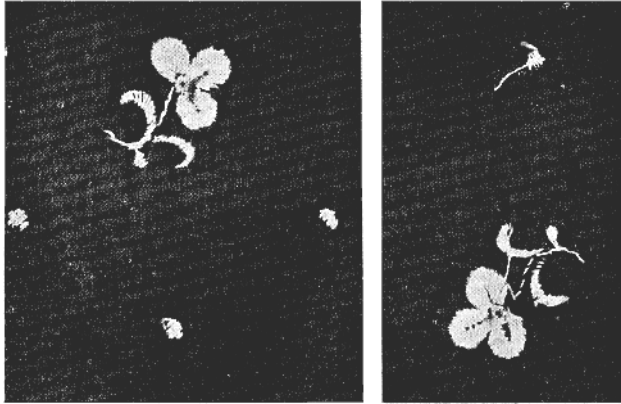

Fig. 351.

Comparison of Swivel Ornamentation and Embroidery.—Fabrics of a light transparent character are largely ornamented on this principle, but almost any structure and ground weave may be employed, and many rich and compact silk fabrics are spotted with swivel weft; while in some cases, in order to exhibit a particular part of a design prominently, a swivel figure is combined with a ground weft or warp figure. Effects are readily produced that appear and handle very similarly to styles in which the pattern is formed after weaving by embroidery; and in order that comparisons may be made, an illustration of an embroidered figure is given in Fig. 351, the face side of the cloth being shown on the left, and the underside on the right. The embroidery thread is wrapped round and round the threads of the foundation texture, and the figure shows as prominently, though with less neatness, on the reverse as on the right side of the fabric. A distinguishing feature of the embroidered designs, which is illustrated in Fig. 352, is that the figuring threads may be inclined at any angle in the cloth. In swivel effects, however, the figuring threads are always traversed parallel with the weft threads of the foundation cloth, and at right angles to the warp threads.

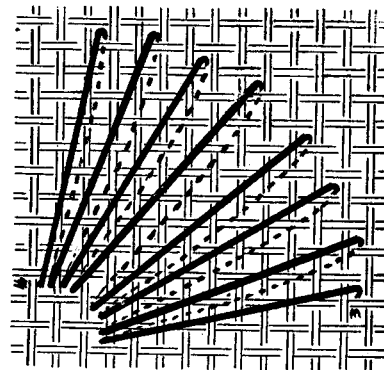

Fig. 352.

General Description of Swivel Mechanism.—A view of a power swivel loom, as made by Messrs. William Smith & Brothers, of Heywood, is given in Fig. 353, from which a general idea can be obtained of the machine, and of the cloth during weaving. The small shuttles are carried in holders supported in a frame which is mounted in front of the slay, and the cycle of operations, while the swivel figure is being formed, is briefly as follows:—After the insertion and beating up of each pick of ground weft in the ordinary manner, the ends are raised that the swivel weft has to pass under (or over on the face side); the frame that carries the swivel

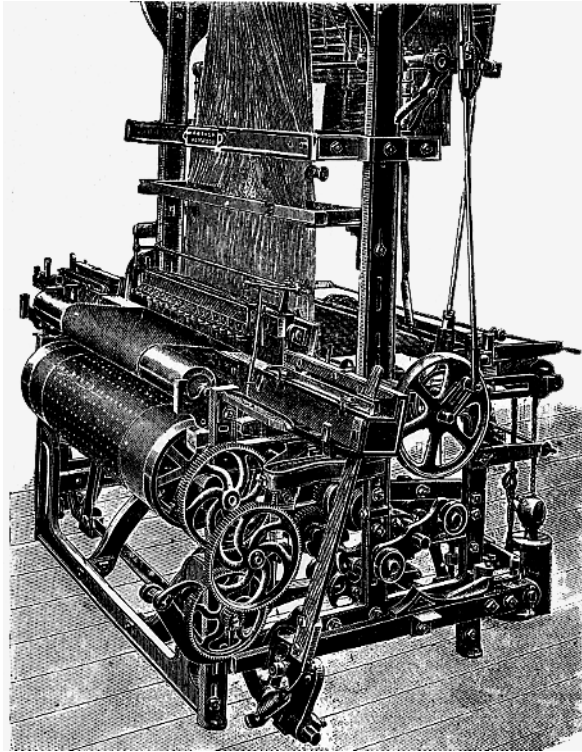

Fig. 353.

shuttles is lowered into the shed opening, each shuttle is moved from one holder to another through the shed made for it, and inserts a separate pick of weft, while the ordinary picking motion is thrown out of action; then the carrying frame is raised out of the way, and during the beating-up of the swivel picks the take-up motion is rendered inoperative. The motions are mainly controlled by the jacquard cards acting upon special hooks from which cord and lever connections are made to the respective parts of the swivel mechanism.

Relation of Pitch of Shuttles to Repeat of Jacquard.—The pitch of the shuttles should bear a definite relationship to the width of repeat that the jacquard will give; and there are three factors to

take into account—viz., the pitch of the shuttles, the number of jacquard hooks tied up, and the number of harness cords per inch. For instance, a machine tied up to 600 hooks with 100 harness cords per inch will give a repeat of 6 inches in the reed. Therefore, if there are two swivel shuttles to each repeat, the pitch will be 3 inches; if three shuttles, 2 inches; if four shuttles, $1\frac{1}{2}$ inches; and if six shuttles, 1 inch. Conversely, a given pitch of the shuttles will determine what sett of jacquard is suitable for a certain number of hooks tied up—*e.g.*, if the pitch is 3 inches, 100 ends per inch are suitable for a 300 tie giving one swivel shuttle to the repeat, and 64 ends per inch for a 384 tie giving two swivel shuttles to the repeat. Again, a given number of harness cords per inch will determine the number of hooks to tie up to suit a certain pitch of the

shuttles. For example, with 96 harness cords per inch and the shuttles 2-inch pitch, the number of hooks tied up may be 192, 384, 576, etc., according to the number of swivel shuttles required to each repeat.

Detached Swivel Figures.—A typical swivel spot figure, on a plain foundation, is illustrated in Fig. 354, the face side of the cloth being shown on the left, and the reverse side on the right. The point-paper design (on a reduced scale) is given at A in Fig. 355; at B the face floats of the first figure are indicated with the swivel picks arranged alternately with the ground picks; while the corresponding flat view, shown at C, illustrates how a swivel thread is traversed in forming a figure. A complete spot is formed by one thread which is traversed alternately to right and to left on succeeding swivel picks; and as many swivel shuttles are employed as there are spots in a horizontal line of the cloth. Upon the completion of a line of spots, the swivel mechanism is thrown out of action until the commencement

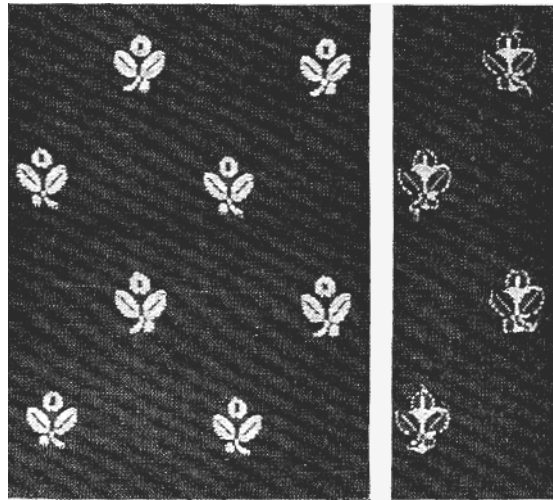

Fig. 354.

of the second line, when the carrying frame is situated so that the shuttles occupy the intermediate position, and the swivel threads are traversed again to right and to left in forming the figures which alternate with those in the first row. The mechanism is once more inoperative, until the shuttles are moved back to the original position in order to repeat the first line of figures; and, as shown by the dotted lines in A, Fig. 355, a thread floats loosely on the reverse side of the cloth from one spot to another. The floating threads are afterwards cut away, and this is the only waste of the swivel weft that is made, in addition to the ordinary weaving waste. It will be noted in A, Fig. 355, that on the first and last picks of each figure the swivel weft is firmly interwoven. This is in order that the free ends of the threads will not be liable to fray out of the foundation. As the cloth is woven wrong side up, the marks of the plan A indicate warp, and are, therefore, cut. A ground card is cut for each horizontal space in the full plan, hence there will be 64 ground and 50 figuring cards in the repeat of A,

which will be arranged 1 ground card, 1 figuring card, for 25 times, and 7 ground cards.

From the example given in Figs. 354 and 355 it will be seen that each swivel shuttle can be employed to ornament the cloth over a certain area in a longitudinal line. In forming spot figures in which the width of the repeat is equal to twice the pitch of the shuttles, it is necessary for all the shuttles in a frame to be traversed

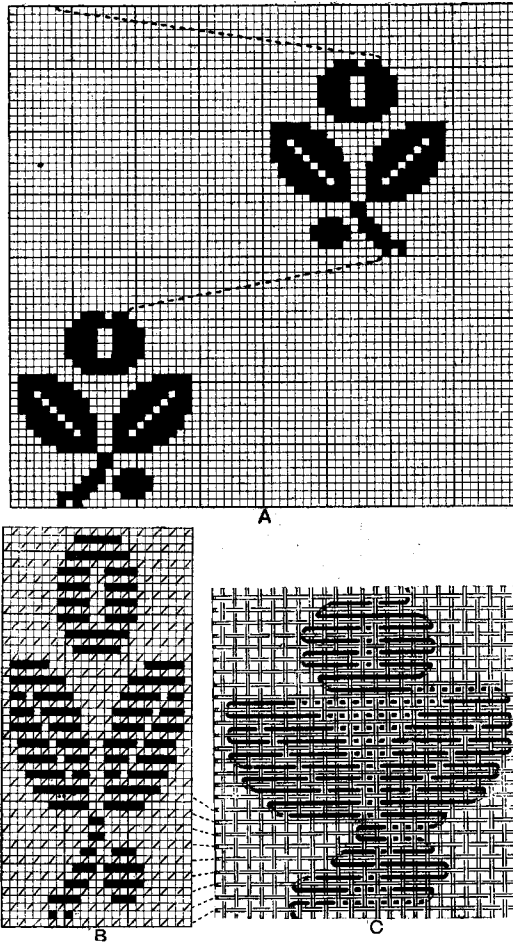

Fig. 355.

while G corresponds with F, with the ground picks included. The way in which a figuring thread is traversed in forming a spot is illustrated at H, in which it will be seen that the moves are always to the right on the face side, and to the left (indicated by dotted lines) on the reverse side. In this case the swivel shuttles, after having been passed through the shed in one direction, are moved in the reverse direction about the time that a ground pick is inserted, and while the carrying-frame is raised clear of the warp. Each figuring thread thus

from one holder to another, but the weft is withdrawn only from those which are passed through a warp shed. In such a case an alternate arrangement of spots can be woven without the carrying frame being moved laterally, the odd shuttles forming one row of figures, and the even shuttles the figures that are intermediate.

Imitation of Embroidery.—

The method of traversing the swivel threads illustrated in Figs. 354 and 355, while producing a prominent effect on the face side of the cloth, does not yield the same bulkiness of figure that embroidery does, because, on the reverse side, the floats of the threads occur only between the detached parts of the figure, as shown by the dots in C, Fig. 355. Fig. 356 shows on the left and right respectively the face and reverse side of a spotted fabric, in which the swivel figure more closely resembles an embroidered style. A reduced plan of the design on the right side of the cloth is given at D in Fig. 357; at E the swivel floats of a spot are indicated alternately with the ground picks; F shows the form of a spot on the underside;

passes round and round the warp threads ; but while it is possible to interweave the threads in any required order on the face side of the cloth, the floats on the reverse side cannot be bound in in any way. This method, while giving bulk to the figure, necessarily consumes more swivel weft than the system illustrated in Figs. 354 and 355.

The two methods of traversing the figuring threads are sometimes combined in the same design as, for instance, in such styles as the example given in Fig. 358, in which waved vertical lines of figure are combined with a small spot effect. In order to give greater prominence and an embroidered appearance to the spots, in each horizontal line where the spots occur, all the figuring threads are traversed in the manner illustrated in Figs. 356 and 357 ; whereas on the picks between the spots, where the waved figure only is formed, the traversing is as shown in Figs. 354 and 355.

Special Swivel Style.—In most cases the swivel picks are introduced alternately with the ground picks, but other orders of wefting are readily arranged for, and an example is given in Fig. 359, in which there are six ground picks to each swivel pick. The upper portion of the figure shows the face, and the lower portion the reverse side, of the cloth. Each zig-zag line of figure is formed by one swivel thread which is stitched into the cloth by means of extra warp threads that are of the same colour as the figuring thread. This arrangement is in order that the swivel interweaving will form solid lines of colour on a ground of a contrasting colour. Another feature of the style is that the cloth is woven right side up. In the plan given in Fig. 360, which illustrates the principle of construction, all the marks

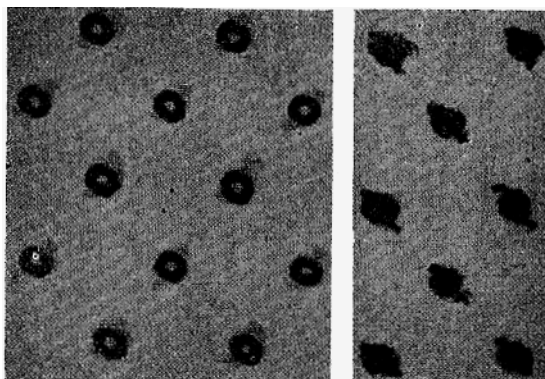

Fig. 356.

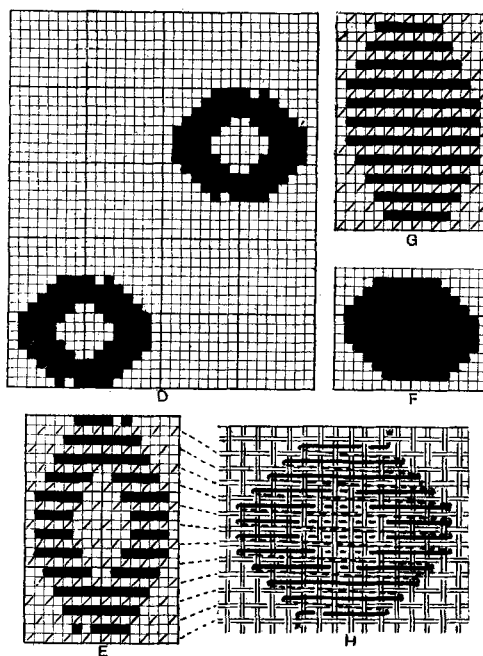

Fig. 357.

the principle of construction, all the marks

represent weft float; the full squares show where the swivel weft floats on the surface, the diagonal strokes indicate a 2-and-2 twill foundation, while the crosses



Fig. 358.

indicate where the extra warp threads are on the underside. The vertical floats of the swivel weft are obtained by the shuttles being held above the line of the shed while each series of six ground picks is inserted. Only five figuring and four

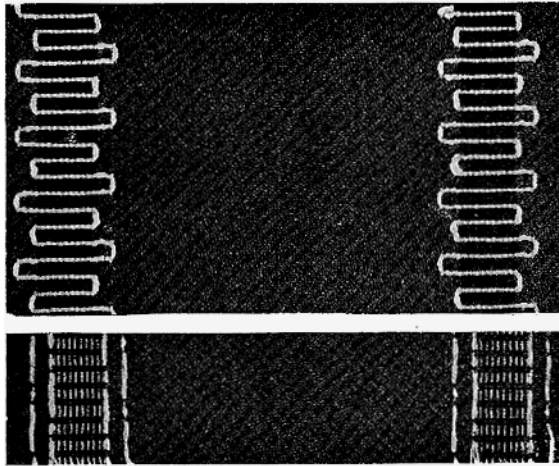

Fig. 359.

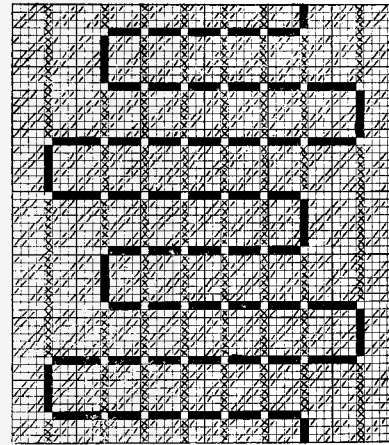

Fig. 360.

ground healds are required, and the example is illustrative of how good swivel effects may be obtained in dobby shedding.

Figuring with two or more Swivel Wefts.—Some types of swivel looms are constructed with only one series of swivel shuttles, and not more than one kind of swivel weft can be inserted at a place. Other looms are provided with two or

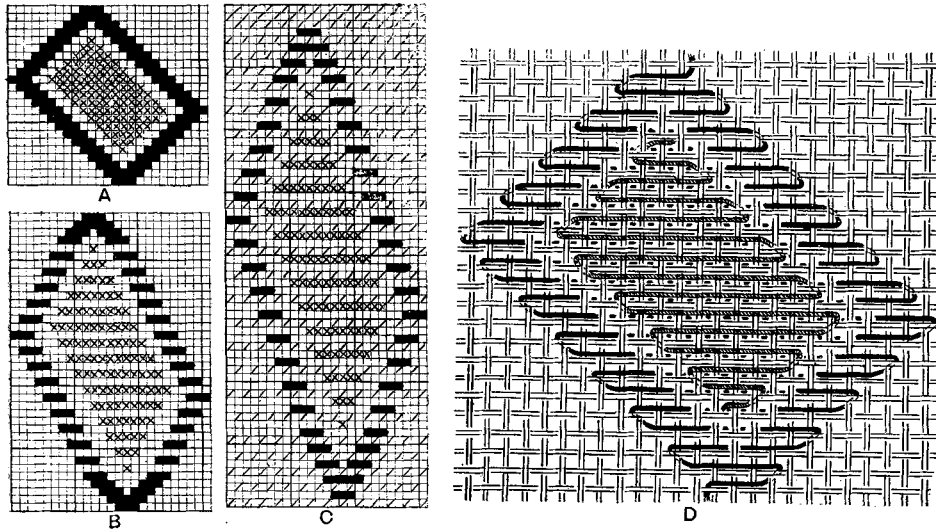

Fig. 361.

more “decks” or “banks” of shuttles which enable a figure to be formed by two or more colours in combination. More than three colours, however, are rarely employed—particularly in power swivel looms—on account of the increase in the complexity of the mechanism that each additional series of shuttles neces-

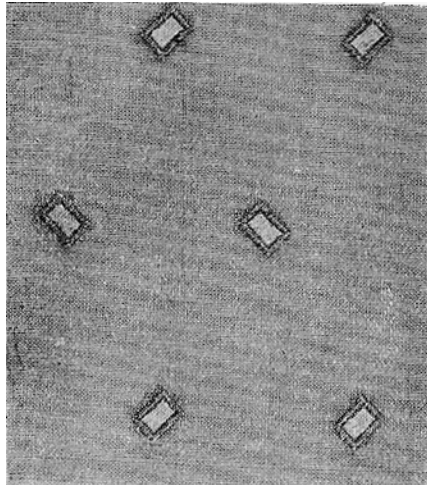

Fig. 362.

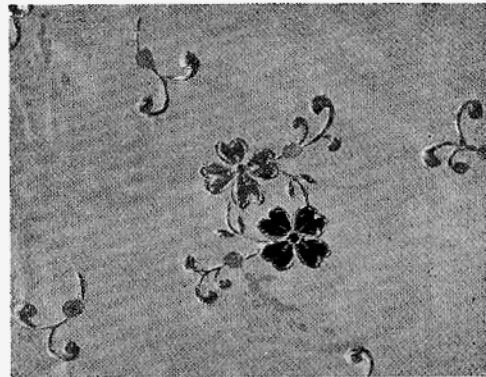

Fig. 363.

sitates. An illustration of a simple spot formed in two colours is given in Fig. 362. A in Fig. 361 shows how a figure is indicated upon design paper,

the different marks representing the different colours ; at B the order in which the swivel figuring cards are cut is indicated ; C illustrates the complete arrangement of the picks which compose one figure, while at D the corresponding flat view of the structure is given. When both figuring colours are inserted the two banks of swivel shuttles are operated in succession (holes being

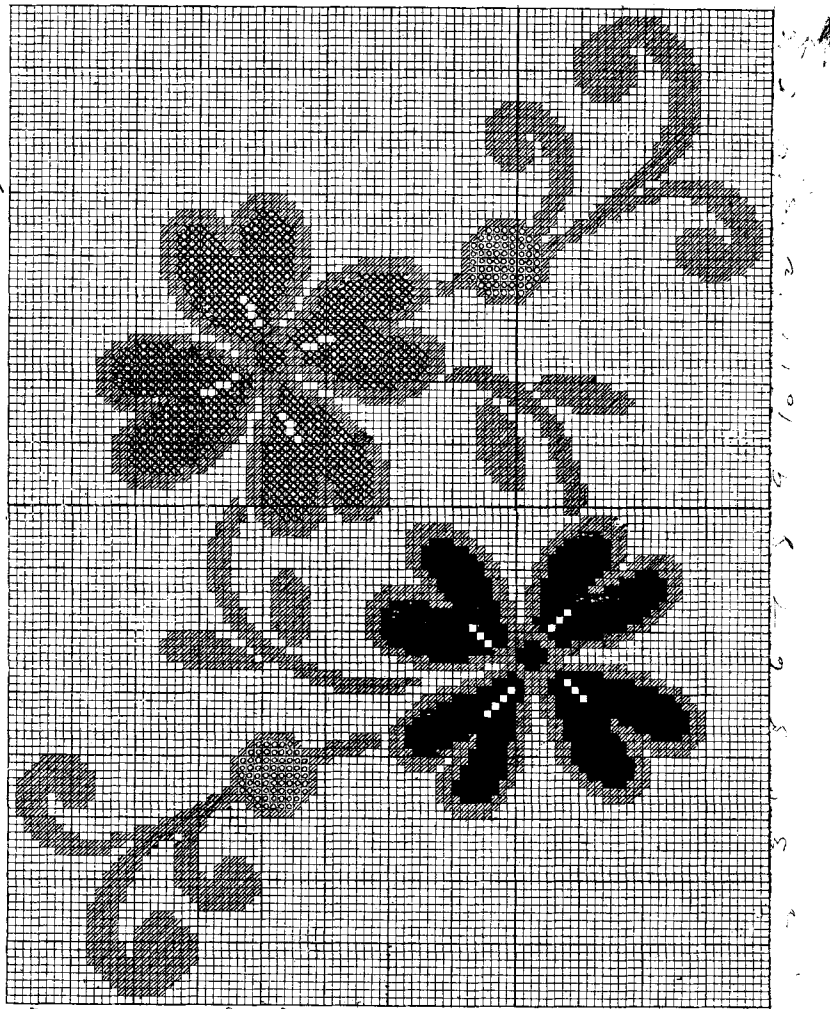

Fig. 364.

cut opposite the controlling needles in the respective cards), and there are two swivel picks to each ground pick. The order of arranging the cards for the example is as follows :—1 ground card, 1 first swivel card for 4 times ; 1 ground card, 1 first swivel card, 1 second swivel card for 15 times ; 1 ground card, 1 first swivel card for 4 times ; followed by the required number of ground cards

between the figures. After one row of figures has been formed, both series of shuttles are moved together to the position where the intermediate figures are produced. The swivel weft, which forms the outline of a figure, floats on the back below the central spot produced by the second colour of weft.

Combination of Swivel and Ordinary Figures.—Fig. 363 shows a swivel figure in two colours which is combined with and surrounded by a figure formed of the ground weft, and there are also spots produced by floating the warp. A corresponding sectional plan is given in Fig. 364, in which the shaded squares represent the ground weft figure, and the circles the warp figure; while the solid marks indicate the floats formed by one swivel weft, and the crosses those formed by the

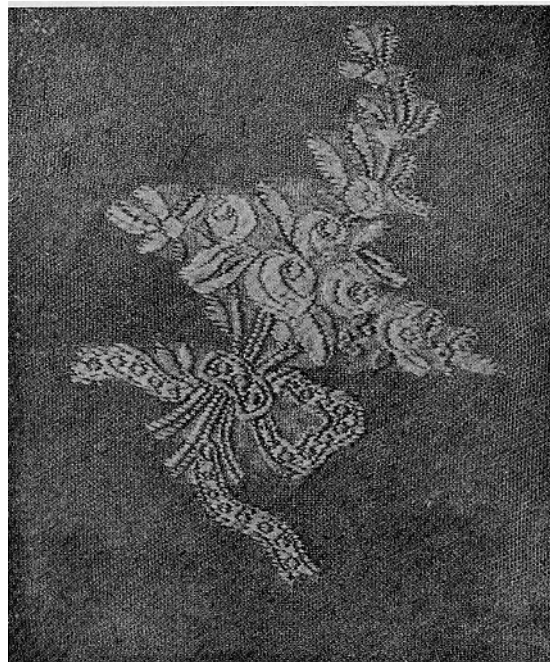

Fig. 365.

other swivel weft. All the marks are cut except the circles, the ground weft figure being cut on the ground cards while the ground weave is continued under the swivel figure. A ground card is required for each horizontal space, and a swivel card where the solid marks and the crosses are indicated; but in this case one swivel colour follows the other, hence there are never two swivel cards to a ground card. The complete arrangement of the cards for the plan, shown in Fig. 364, is as follows:—26 ground cards; 1 ground card, 1 first swivel card for 35 times; 1 ground card; 1 ground card, 1 second swivel card for 40 times; and 26 ground cards.

A two-colour swivel figure is given in Fig. 365, which is much larger and more elaborate in character than any of the preceding examples, and illustrates the

diversity and intricacy of interlacing that can be obtained in swivel weaving. The ground yarns are not used in forming the effect, but both colours of swivel weft are introduced throughout the figure, therefore the form is painted in solid in two colours on design paper in the manner illustrated at A in Fig. 362, and two figuring cards are cut from each horizontal line of spaces. The complete figure is formed by one thread of each colour, and is a combination of stems, leaves, and flowers which are more or less detached from each other; and the foundation texture is a light gauze. As the swivel threads float on the underside between the separate parts of the figure, they are visible from the face side on account of the transparency

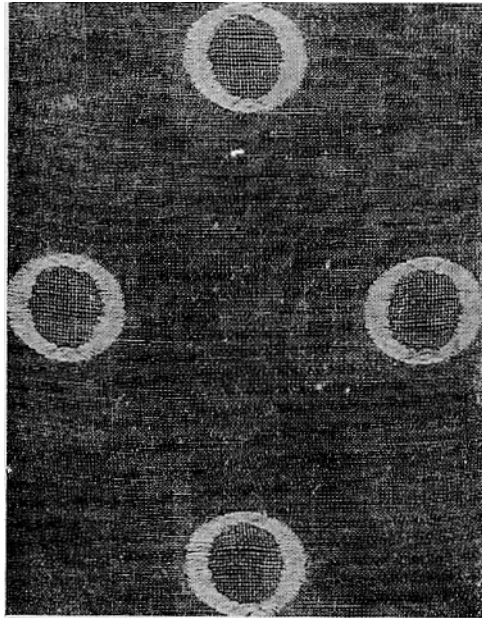
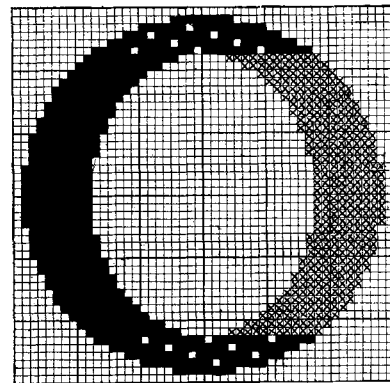
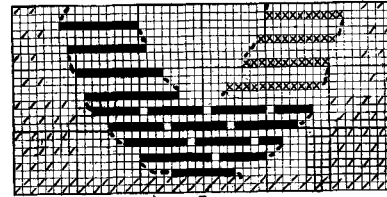

Fig. 366.



A



B

Fig. 367.

of the foundation, and the opaque background thus formed detracts from the clearness and precision of the figure.

Production of Detached Figures in One Kind of Weft by Two Shuttles.—

In order to avoid the defect described in the preceding paragraph, sometimes two banks of swivels are employed when only one kind of weft is used for figuring, and an example is given in Fig. 366 which shows a circular spot with an open-work centre formed on a thin muslin foundation. A representation of one figure is given on point-paper at A in Fig. 367, which shows that the top, bottom, and one side of a spot are formed by one shuttle, and the other side by a second shuttle. Where the open centre of the figure is formed, after each ground pick, the two series of shuttles are operated in turn in succeeding sheds, one shuttle forming one side of the spot, and the other shuttle the other side, with the result that there is no weft stretching between on the underside. B in Fig. 367 shows the full plan of the first 10 picks of A (except that the ground weave is not inserted under the

figure), and the manner in which the threads are traversed by the different shuttles is indicated.

The top and bottom of each circular spot in the foregoing example are formed by one shuttle only, in order that the output will not be curtailed by the second series of shuttles being brought into action when not absolutely necessary. In Fig. 368 a similar form of spot, with an open centre, is illustrated; but in this case, as shown by the plan of one spot given at C in Fig. 369, each entire half of a figure is formed by a separate shuttle. Other forms of figures, consisting of two detached parts, can, of course, be formed in one kind of weft in this principle. A double-decked swivel-loom may be employed, the two series of shuttles being operated in succession on different sheds; but in another type of loom, which is illustrated in Figs. 375, 376, and 377, only one bank of shuttles is employed, all of which are operated at the same time. In the latter case a swivel shed is formed alternately

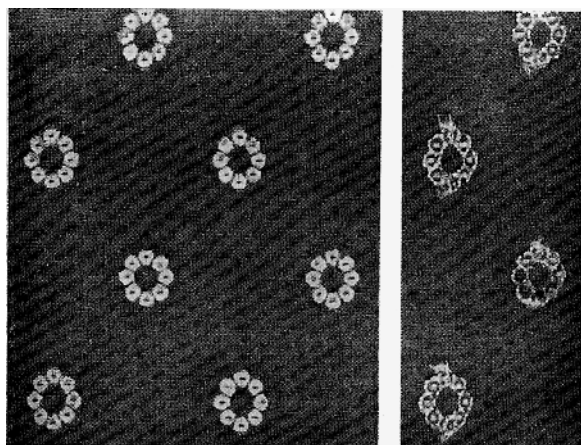

Fig. 368.

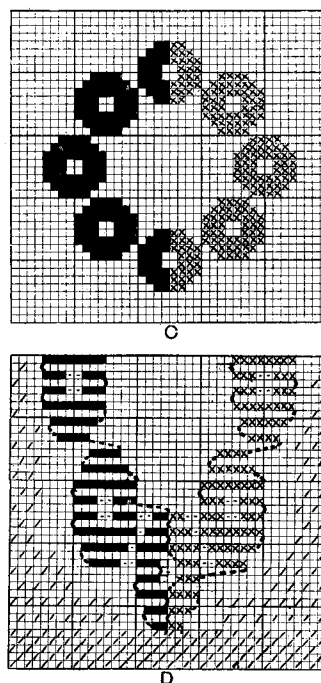

Fig. 369.

with a ground shed, as indicated at D in Fig. 369, which shows the full plan of the first 22 picks of C.

All-over Swivel Figures.—A limitation in certain types of swivel looms is, that some distance in a horizontal direction must separate the figures, in order that there will be spac. for the shuttle-holders to drop in between the groups of ends that are lifted. The minimum distance between the figures varies in different classes of swivel mechanisms, modifying factors being the size of the shuttle, the way in which the shuttles are held, and the space across which the threads have to be traversed. Such looms can only introduce the swivel weft to form spots or stripes, as in the examples that have been illustrated. There are other types of swivels, however, which (in a further development of the principles illustrated in Figs. 366 to 369) are so constructed that it is possible to distri-

bute the ornament over the whole of the surface of the cloth, and either detached figures or all-over designs in one kind of weft can be produced. Illustrations of all-over designs are given in Figs. 370 and 372, and the corresponding sectional plans in Figs. 371 and 373. The different marks in the plans divide the figures into longitudinal sections, each of which is formed by a separate shuttle; and from a comparison of the two examples it will be seen that different methods of production are employed. Fig. 370 shows a hand-loom style in which four separate swivel shuttles are employed in forming each repeat of the design. The odd and even shuttles are in different series, and the two banks are operated in turn after each ground pick. Therefore, each horizontal space in Fig. 371 represents a ground



Fig. 370.

card and two figuring cards, the full squares being cut on one of the latter, and the shaded squares on the other. The odd shuttles are lowered into the shed in the space where the figure is formed by the even shuttles, and *vice versa*; the portions of figure produced by one bank being far enough apart to allow the shuttles of the other bank to drop in between the groups of threads that are raised.

In Figs. 370 and 371 each shuttle at different times traverses a comparatively large number of threads, and in some places threads which are traversed by one shuttle in one portion of the design are traversed by another shuttle in another portion. On the other hand, in the example illustrated in Figs. 372 and 373, which is a power-loom style (Fig. 372 showing the face and reverse sides of the cloth

on the left and right respectively), each shuttle is confined to a definite longitudinal area of the cloth. The pitch of the shuttles is about $\frac{1}{2}$ inch, and 12 shuttles are employed in forming a repeat of the design, each figuring exactly over the width of 32 ends, as shown in Fig. 373. In this case only one swivel shed is formed

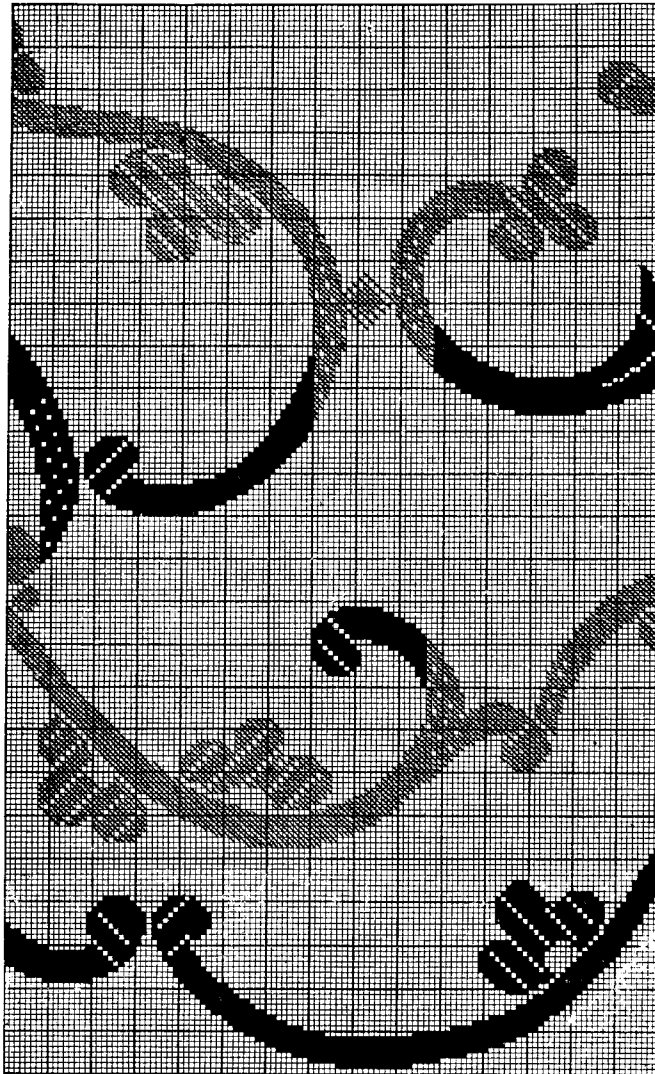

Fig. 371.

to each ground shed; therefore, each horizontal space in the plan represents a ground card and a figuring card, all the marks of the design being cut on the latter. The parts of the figure are joined up with perfect accuracy, one thread completing its interweaving where the next thread commences, as shown in the

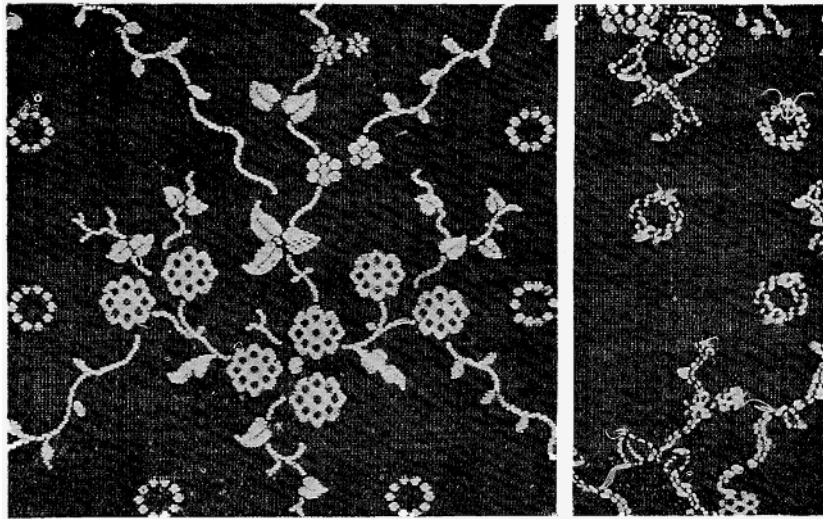

Fig. 372.

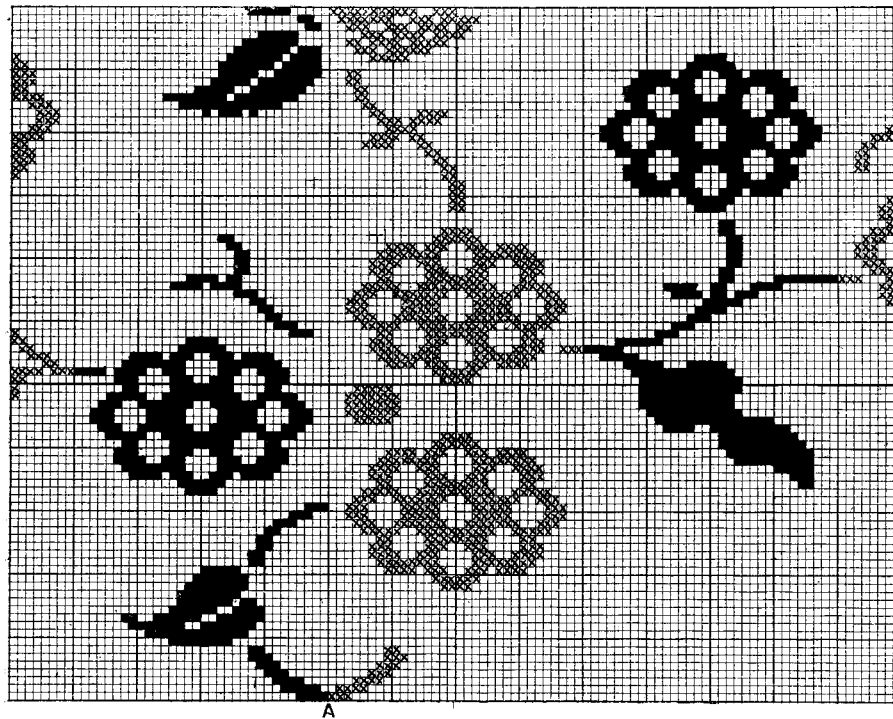

Fig. 373.

position lettered A in Fig. 373. In designing figures, however, the masses are generally so arranged that, while avoiding any tendency to stripiness, as few junctions as possible of the separate threads need to be made. When a transparent ground effect is required between two detached parts of the figure, it is necessary for the two portions to be formed by separate shuttles; thus, in Fig. 372 one side of each open spot is formed by one shuttle, and the other side by another shuttle. In the production of spot figures on this principle a lateral movement of the swivel-carrying frame is not necessary, since every portion of the width of the

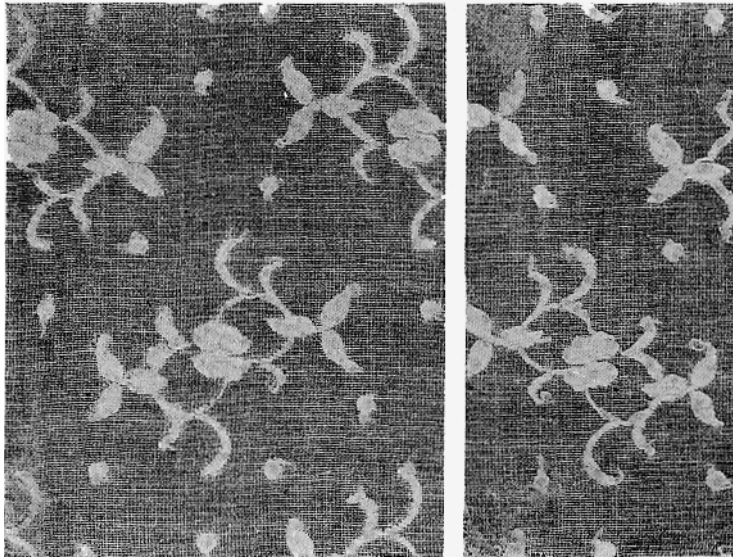

Fig. 374.

cloth is within the traverse of one or other shuttle, while if no ends are lifted in the line of traverse of a thread no figure is formed.

In Fig. 372 the traverses of the swivel threads are alternately to left and to right on the surface, and there is very little weft floating on the reverse side, which has a bare and flat appearance. An imitation of embroidery can, however, be obtained in the all-over figured styles, and an illustration is given in Fig. 374, in which each swivel thread is floated across the figuring ends on the underside in the manner described in reference to Figs. 356 and 357 (p. 339). The figure on the reverse side of the cloth (shown on the right of Fig. 374) has a rough appearance, but it is quite as prominent as on the surface. The designing of the figure is not affected by the way in which the threads are traversed, the only difference being in cutting the cards opposite the needles which govern the movements of the shuttles.

POWER-LOOM SWIVEL MECHANISMS

All-over Figuring Swivel Loom.—A view of the type of swivel loom in which figures may be produced either over the whole of the surface of the cloth, as shown in Figs. 372 and 374, or in the form of detached spots, as shown in Fig. 368, is given

in Fig. 375. This loom is made by Messrs. Crompton & Knowles, U.S.A., and the chief features to note in Fig. 375 are the parts and their connections at the top of the loom to which the jacquard cords are attached, and the position and shape of the minute shuttle-holders and shuttles in front of the going part.

The principal movements of the swivel mechanism are illustrated by the drawings in Fig. 376, while the details by which the movements are governed are shown in Fig. 377. The same letters are used throughout for the parts which

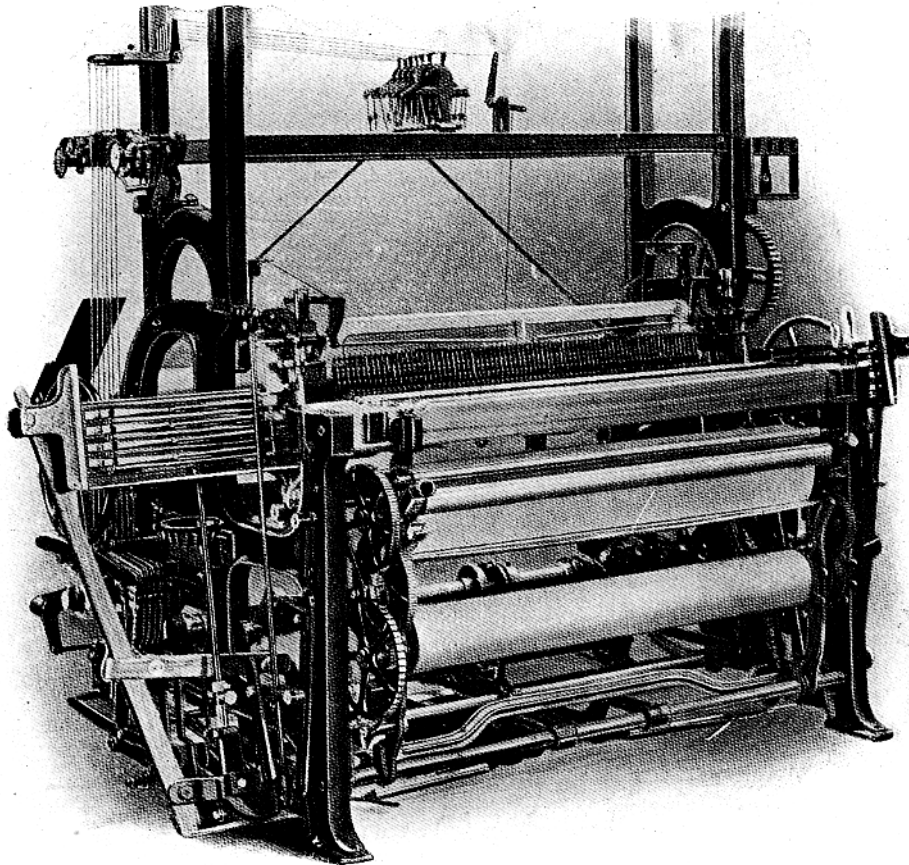

Fig. 375.

correspond. The carrying frame A consists of a transverse bar to which are fastened by screws the swivel shuttle-holders B, each of which is in the form of a downwardly extending finger that is pointed and curved towards the reed at the lower end, as shown in the drawings Nos. 1 and 3 in Fig. 376. Each swivel shuttle C extends in a horizontal plane from a holder B, the two being so shaped that a lip on one fits into a groove in the other. The pitch of the shuttles is usually about $\frac{1}{2}$ inch, and a small space separates the holders from one another, as shown in the drawings Nos. 4 and 5. The spools are held by the shuttles C in a position at right angles to the slay, and the threads pass from them through openings in the bottom

of the shuttles. A spindle extends through each spool, and in order to prevent the latter from over-running as the thread is withdrawn, it is tensioned by two spiral springs D placed upon the spindle, as shown in the drawing No. 1. A shuttle may be open on its upper side, as shown in the drawings Nos. 1 and 3, or it may be in the form shown at 2, in which the spool is supported in a removable metal carrier E which is held in two vertical grooves in the body of the shuttle. The advantage of the latter arrangement is that the tension on the spool can be properly regulated as it is placed in the carrier, so that no further adjustment is required when the carrier is placed in the shuttle.

In placing the shuttles C in the shed opening, as shown in No. 3, the carrying frame A is lowered, and the pointed ends of the shuttle-holders B, as they descend into the shed, divide the warp threads that are raised and push them in groups into the spaces between the holders. The shuttles are then moved transversely from one holder to another by means of the levers F (shown in the drawings Nos. 3, 4, and 5), the lower ends of which engage with the necks of the shuttles. Any warp threads that are raised by the jacquard will be passed under by one or other of the shuttles, and weft figures may be formed on the underside at any desired place across the entire width of the cloth. Where no threads are raised the shuttles simply pass from one holder to another without any swivel yarn being withdrawn from the spools.

Each lever F is pivoted on a shuttle-holder B by a pin G, and its upper end passes loosely through a stud H, which is free to turn on its centre. The studs H are carried by a sliding bar I which is mounted on the upper grooved edge of the carrying frame A, in such a manner that it can be slid longitudinally, and transmit, by means of the levers F, the transverse movement to the shuttles. After a shuttle has completed its traverse, it is held

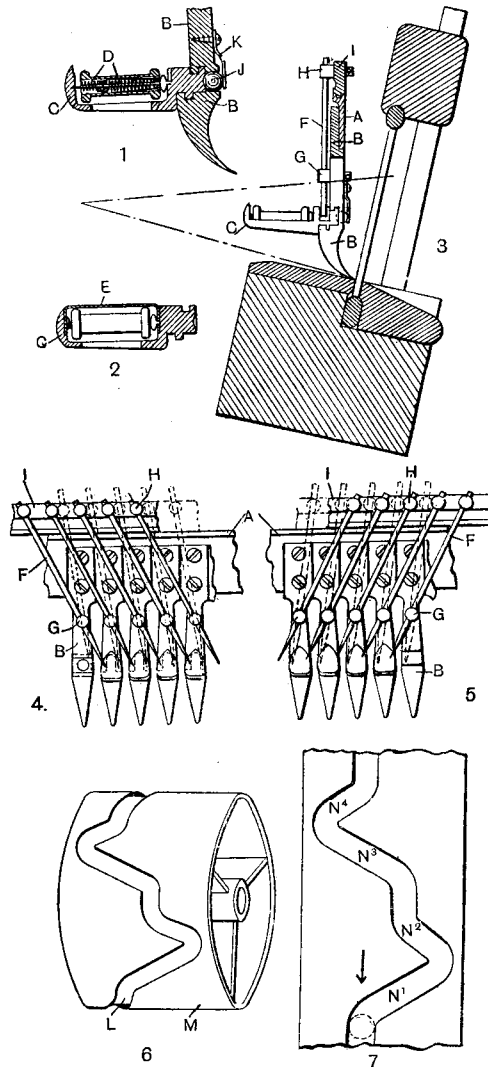

Fig. 376:

firmly in position by a ball J (shown in the drawing No. 1), which is pressed into a depression at the rear of the shuttle by means of a spring K.

At the time of lowering and raising the carrying frame A, the levers F require to occupy one of the positions shown in dotted lines in the drawings Nos. 4 and 5, in order that they will not obstruct the warp threads ; while in traversing the shuttles the levers are moved from the dotted position shown in one drawing to the position shown in full lines in the other drawing. The complete round of movements of the levers F, during which two swivel picks are inserted, is as follows :—

1. From the dotted position shown in No. 4, to the full line position shown in No. 5.
2. From the full line position shown in No. 5, to the dotted position shown in No. 5.
3. From the dotted position shown in No. 5, to the full line position shown in No. 4.
4. From the full line position shown in No. 4, to the dotted position shown in No. 4.

The swivel shuttles are traversed to the left at the first movement, and to the right at the third movement. Between the second and third, and the fourth and first movements, the carrying frames is raised, and remains up while a ground pick is inserted ; the frame is then lowered. The movements are governed by a cam groove L cut in the periphery of a drum M (shown in the drawing No. 6), which is turned one-sixth of a revolution at each swivel pick. An anti-friction bowl N, carried at the end of a lever O (shown in the drawings Nos. 12 and 13 in Fig. 377), travels within the cam groove, and the drawing No. 7 in Fig. 376 shows in plan the portion of the groove by which the complete round of movements of the levers F is obtained ; the arrow indicates the direction of revolution. The first movement is obtained by the bowl travelling along the long portion of the groove marked N¹, while the short portion marked N² produces the second movement ; there is subsequently an intermission of the rotation of the drum during which the carrying frame is raised and again lowered. The third movement is produced by the long portion of the groove marked N³, and the fourth movement by the short portion marked N⁴, after which the drum is again at rest while the carrying frame is raised and lowered. The drum M is stationary all the time that no swivel weft is being inserted.

The mechanisms which govern the picking of the fly shuttle, raise and lower the carrying frame A, and give the longitudinal movement to the sliding bar I, are illustrated in Fig. 377. Certain hooks in the jacquard are employed for controlling the motions, and the drawings Nos. 8 and 9 (the latter on an enlarged scale) show the parts which communicate the movement from the jacquard to the loom. Cords P, from the jacquard hooks, are connected to two arms which form an extension from a cam Q (see drawing No. 9) fulcrumed on a stud R that passes through a horizontal slot in a rocking lever S. At the sides of the slot pins T are fixed to the lever S in a position to be engaged by the cam Q. The stud R is fixed to a bracket U on which the rocking lever S is pivoted at its lower end, and from the upper end of S a cord V passes either over a guide pulley or is connected to the upper arm of an angle lever W, as shown in No. 8. Lifting a cord P causes the cam Q to turn on the stud R and engage a pin T connected to the rocking lever S, the upper end of which, therefore, moves to the left if the right-hand cord P is raised, and to the right in the case of the left-hand cord. A lever, fulcrumed on the upper central part of the cam Q, serves, by means of the springs that are connected to it, to lock the cam in either position to which it is moved by the cords P.

The fly shuttle picking motion is on the slide principle, and the parts which throw the mechanism into and out of action are shown in the drawings Nos. 10 and 11 in Fig. 377. Two sliding rods *b* and *c* are connected at their inner ends to

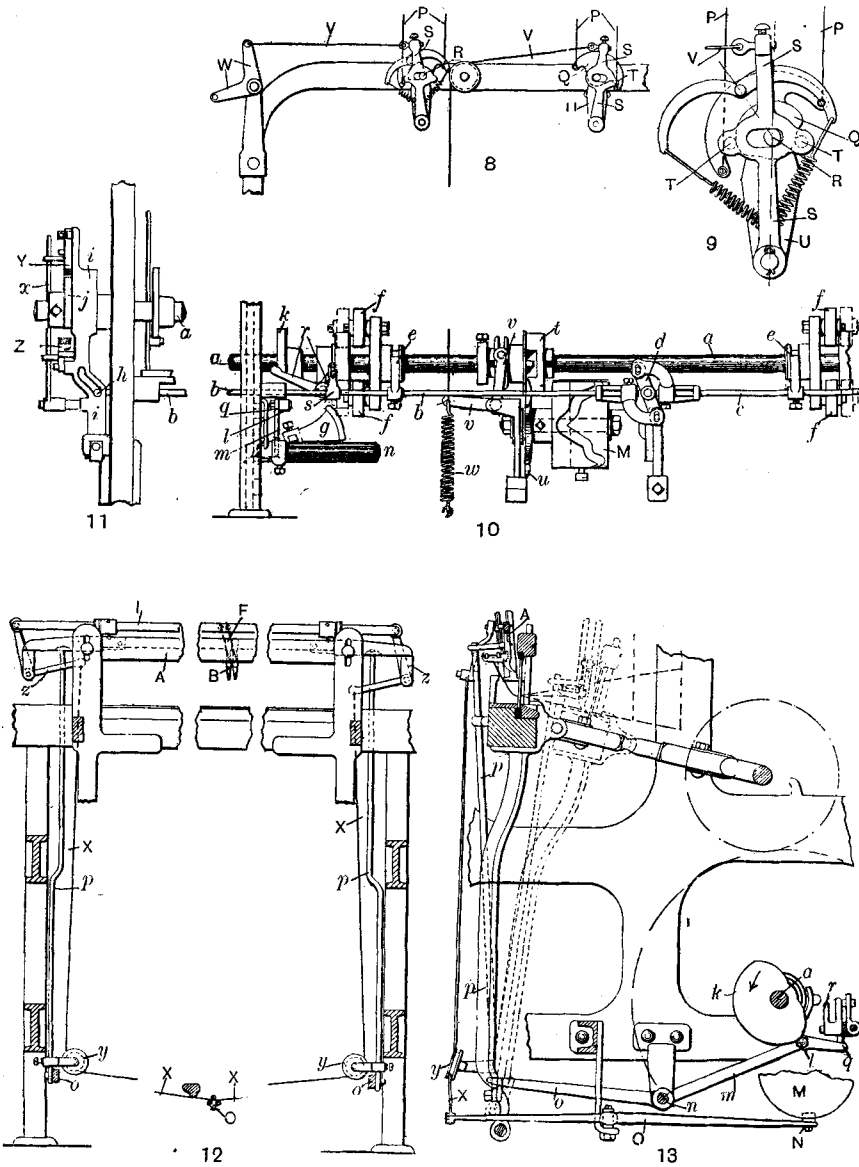

Fig. 377.

a lever *d* in such a manner that when the rod *b* is moved in one direction, the rod *c* is caused to move at the same time in the opposite direction. Each rod has secured to it a forked arm *e* which engages with the grooved hub of the casting that carries

the picking rolls f , and according to the direction of the movement of the rod b , the picking rolls are slid along the bottom shaft a into or out of engagement with the picking shoes g . The arrangement by which the sliding movement is imparted to the rod b is shown in plan in the drawing No. 11. The rod b extends through the framing of the loom, and carries on its outer end a stud h which enters a diagonal slot in an arm i . A cord from the lower arm of the lever W (shown in the drawing No. 8) is attached to a lever x , the raising and lowering of which bring in turn two fingers Y and Z —connected to the arm i —in the path of a tappet j which is keyed on the low shaft a . The tappet j , in engaging a finger Y or Z , gives a longitudinal movement to the arm i , and by means of the slot moves the stud h , and thereby transmits the sliding movement to the rod b .

The carrying frame A is lowered into the shed opening, as shown by the dotted lines in the drawing No. 13, as the going part recedes from the cloth, and is raised out of the way during the forward movement of the slay. The vertical movement of the frame A is effected by a cam k (shown in the drawing No. 13) on the bottom shaft a , which engages an anti-friction bowl l carried at the rear end m of a lever that is fulcrumed on a rocking shaft n . The weight of the parts is sufficient to keep the bowl l in contact with the cam k (if necessary a spring may be used in addition), and as the cam revolves the shaft n is rocked and the forward end o of the lever lowered and raised. The shaft n extends the width of the loom, and at the opposite side there is another lever o fulcrumed on the shaft. Two upright rods p connect the extremities of the levers o with the ends of the carrying frame A (as shown in the drawings Nos. 12 and 13), which, therefore, at each swivel pick is lowered into the shed opening and is then raised. To each end of the lay an upright slotted stand is fixed in which the carrying frame slides up and down.

When the carrying frame is lowered for the insertion of a swivel pick, the ordinary picking motion is inoperative, and it is very necessary to avoid any possibility of the fly shuttle and the swivel shuttles coming in contact with each other. For this purpose the rear end of the lever m is extended, as shown at q in the drawing No. 13, and whenever the fly shuttle is operated the lower arm of an angle lever r is moved in contact with the upper side of the extension q in the following manner:—The sliding rod b carries a slotted arm s (shown in the drawing No. 10), and into the slot a stud, fixed to the upper arm of the angle lever r , projects. Therefore, when the rod b is moved to the left to bring the picking rolls f into position to engage the picking shoes g (as shown by the dotted lines in the drawing No. 10), the slotted arm s is also moved to the left, and the angle lever r is rocked so that its lower arm engages the extension q of the lever m . The latter is thus prevented from rising, and the carrying frame A from descending, so long as the fly shuttle mechanism is in operation.

The drum M , by which the longitudinal movement of the sliding bar I is governed, is rotated by a pin-wheel t (shown in the drawing No. 10) that engages a six-sided star-wheel u fixed on the hub of the drum. The pin-wheel t is keyed on a sleeve fixed to the bottom shaft a , and the upper forked arm of a lever v is provided with studs which extend into a groove in the boss of the pin-wheel. The lower arm of the lever v is connected by a spring w to the floor, and by a cord that passes upwards over a pulley to a rocking lever S . Lifting the left-hand jacquard cord P causes the pin-wheel t to engage with the star wheel u , and the drum M is turned one-sixth of a revolution. When the right-hand cord P is raised, the

contraction of the spring *w* moves the pin wheel out of engagement with the star wheel, so that the drum remains stationary.

The bowl *N*, that travels in the cam groove of the drum *M*, is carried at the rear end of a lever *O* (shown in the drawing No. 13), which is centrally pivoted in such a manner that as the drum rotates the lever is caused to swing in a horizontal plane. Cords *X* (shown in the drawing No. 12) pass from the forward end of the lever *O* over guide pulleys *y* (which are mounted on brackets secured to the upright rods *p*) to the lower arms of the angle levers *z*, which are pivoted on brackets fixed to the carrying frame *A*. The horizontal movement of the lever *O* rocks the angle levers *z*, the upper arms of which convey a longitudinal movement to the sliding bar *I*, which, by means of the levers *F*, transmits the transverse motions to the shuttles in the manner previously described. In order to produce the appearance of embroidery in the cloth, as illustrated by the pattern in Fig. 374, the drum *M* is rotated one-sixth of a revolution on the ground pick between each pair of swivel picks.

Rack and Pinion Swivel Loom.—A type of power swivel loom is illustrated in Fig. 378 that is used in the production of spot figures which are placed some distance apart horizontally. This system of supporting and actuating the swivel shuttles is a development of the style that has been most commonly used in hand swivel weaving; and in both hand and power looms it is chiefly this type of motion that has been adapted to the use of more than one bank of shuttles. The mechanism illustrated in Fig. 378, which corresponds with the view of a swivel loom given in Fig. 353 (p. 336), and is made by Messrs. William Smith & Brothers, Limited, is, however, only used for one series of shuttles, but the same principles apply when two or more series are employed.

Diagram No. 1 in Fig. 378 shows a front elevation, and No. 2 a section of the upper part of the mechanism from which a general idea of the principles of the motion can be obtained. The carrying frame *A* is recessed at its lower side between the shuttle-holders *B*, and the warp threads are raised for the swivel figuring in the spaces thus provided. The swivel shuttles *C* are held parallel with the slay, and the shuttle-holders *B* are made to correspond in width with the length of the shuttles. In order that the carrying frame may be lowered without obstruction into position for inserting the swivel weft, the distance between the figures must be at least equal to the width of the shuttle-holders. The width over which the swivel weft may be traversed at a place is limited to the space between the shuttle-holders, and this width must be not more than from $\frac{1}{3}$ to $\frac{1}{2}$ of the length of the shuttles, in order that the latter may be moved positively from one holder to another. The size of the shuttles and holders is varied according to requirements: an increase in the space between the figures enables larger shuttles to be used, and the space between the shuttle-holders can then be proportionately increased. In wide repeats, therefore, broader figures can be introduced than in small repeats.

The upper portion of each shuttle-holder *B* is formed of the carrying frame *A*, a lip in the front of which fits into a groove formed in the upper face of the shuttles, but the lower portion is attached to a thin metal plate *D* which is fixed to the back of the frame *A*. A rack *E* is secured in a second groove formed in the rear of each shuttle, and a sliding bar *F*, which extends across the reed space in a groove in the frame *A*, has a leather rack *G* fixed to its underside. The rack *G* engages the teeth of the brass pinions *H*, which are fulcrumed on the pins *I*, and each pinion gears

with a rack E on the upper side of a shuttle. The sliding bar F is caused to move alternately to right and left, and this movement, through the pinions H and racks E, is transmitted to the shuttles, which are moved from one holder B to another, and back again, on succeeding swivel picks. The number of shuttle-holders must be one in excess of the number of shuttles employed.

Diagram No. 3 in Fig. 378 shows a sectional elevation, and No. 4 a plan of the parts which govern the special motions of the loom. The swivel mechanism is brought into action, and the ordinary picking and weft motions at the same time are rendered inoperative by raising the weighted end of a lever J, through the medium of a cord L which is connected to a jacquard hook. The lever J is fulcrumed at K, and when raised by the jacquard—in which position it is shown—a bowl M, which is fulcrumed at an angle on a stud N, is brought against the cam face O of a disc P. The disc P is loose on the low shaft Q, but it is constantly rotated with the latter by means of a connection with a clutch R which is set-screwed on the shaft Q. No. 5 shows the form of the cam, disc, and clutch. By lifting the jacquard cord L the bowl M is lowered into contact with the cam face O of the disc P, and the cam O is so shaped that as it revolves P is caused to slide back along the low shaft against the pressure of a spring S. The end of the lever J is made sufficiently heavy to raise the bowl M out of contact with the cam O when the cord L is lowered by the jacquard; then the pressure of the spring S causes the disc P to slide forward on the shaft Q to its normal position (this is the sole purpose of the spring S). The disc P, which is constantly revolving with the low shaft Q, is retained in its normal position while the ground weft is inserted, and is moved back against the pressure of the spring on each swivel pick. A distinct feature of the mechanism is that the motions are controlled by one lever J, which is acted upon by a single jacquard hook.

The ordinary picking and weft motions are controlled by a cam T on the face of a star-wheel U, which is shown separately in No. 6. A bowl V, carried on the upper extremity of a vertical lever W, is kept in contact with the cam face T. The lever W is fulcrumed on a stud X, and is connected at its lower end with the rods Y and Z, the former of which is attached to the picking plate *a*, fulcrumed at *b* on the picking lever *c*; while the latter serves to control the weft fork mechanism. The disc P carries two pegs *d* (see No. 4), which, when P is in its normal position, engage and turn the star-wheel U one-eighth of a revolution at a time. The rotation of U, through the cam T and bowl V, causes the lever W to rock on its centre X and move the rods Y and Z; and the cam T is so shaped that when one picking plate *a* is brought into position to be engaged by a picking bowl, that at the other side is moved out of position. When the disc P is pressed back, the pegs *d* are moved out of engagement with the star-wheel, which, therefore, remains stationary while the swivel weft is inserted. The backward movement of P, through a small piece of mechanism (not shown in the drawings), causes both picking plates *a* to be moved out of engagement with the picking bowls. The arrangement makes it impossible for the fly shuttle to be operated at the time that the carrying frame is lowered.

The vertical movement of the carrying frame is effected by a cam *e* (which is on the opposite side of the disc P to the face cam O, and is shown in dotted lines in No. 3) and a spiral spring *i*. When the disc P is pressed back, the cam *e* engages a bowl *f* carried on a lever *g* which is fulcrumed on a stud *h*, and its action is to

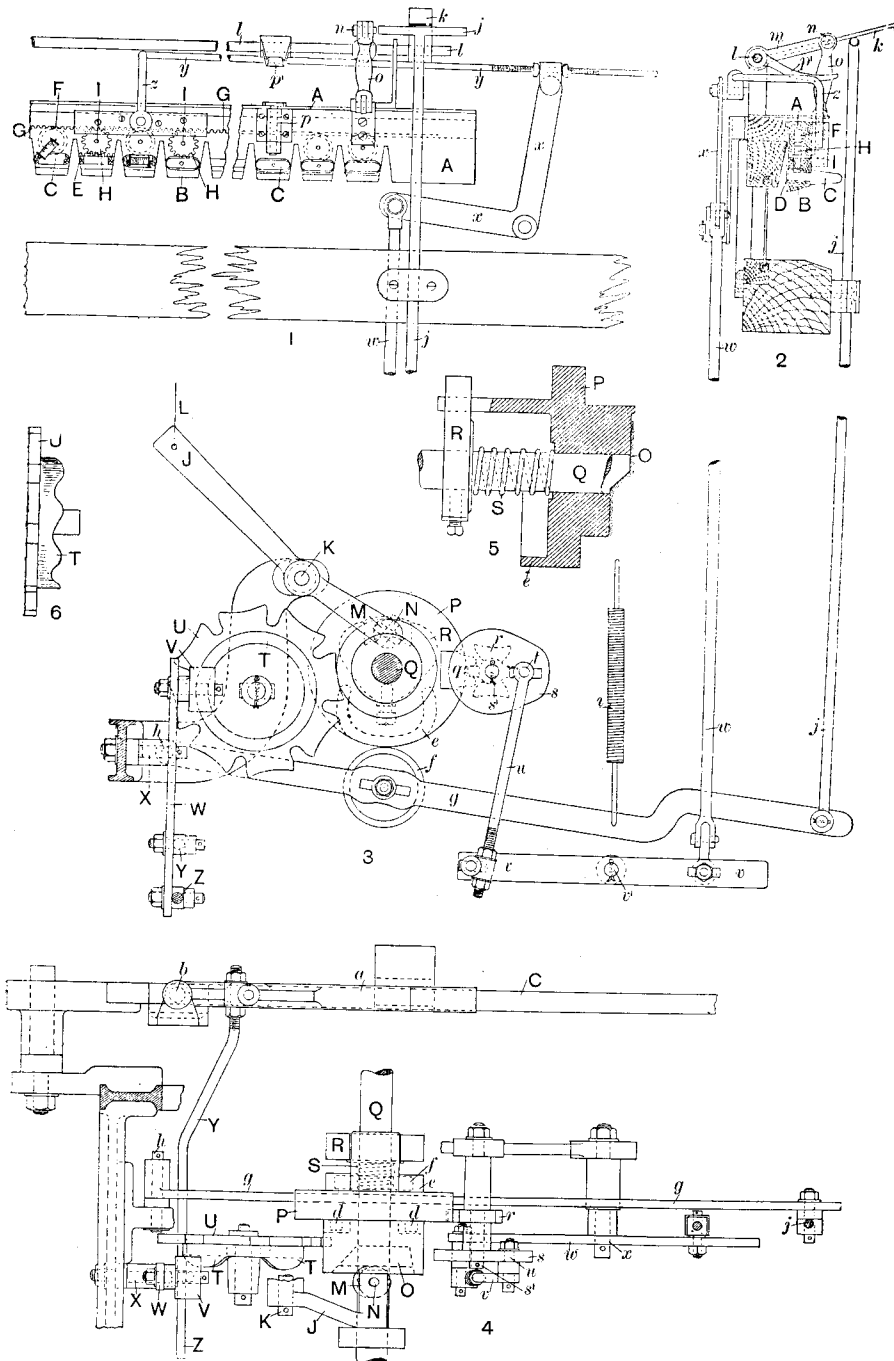

Fig. 378.

depress the lever g against the tension of the spring i ; while the purpose of the latter is to keep the bowl f in contact with the cam e , and to raise the lever g when the pressure of the cam is removed. A rod j , which is connected to the end of the lever g , has resting upon its upper extremity a lever k which is fulcrumed on a rocking shaft l . The shaft l extends across the reed space, and supports at each side a lever m , which carries a stud n on which the upper end of a pendant arm o is fulcrumed; while the lower end of the arm o is secured to the carrying frame A. The weight of the parts is sufficient to keep the lever k in contact with the end of the vertical rod j , so that when the lever g is depressed by the action of the cam e the carrying frame A is lowered into the shed opening. When the downward pressure of the cam e is removed, the contraction of the spring i causes the vertical rod j to push the lever k upwards, and the carrying frame is raised. During the rising and falling movement the frame is steadied at each side by a stud which enters a brass guide p . A lever p^1 , which is fixed to the rocking shaft l , is placed directly over and rests upon each guide, and this lever can be adjusted so as to regulate the distance that the frame descends.

The transverse movement of the swivel shuttles is obtained as follows:—When the disc P is moved back, the teeth q , secured to P by a setscrew, are brought into the path of a star-wheel r , which is compounded with an eccentric plate s , as shown in drawings Nos. 3 and 4. The star-wheel r and the plate s , which are loose on a stud s^1 , are turned one-half of a revolution; and the stud t , carried by the eccentric plate s , is moved from the bottom to the top on one swivel pick, and from the top to the bottom on the following swivel pick. The stud t is connected by the rod u to a lever v , which is fulcrumed at v^1 , and the rotation of the eccentric s causes a vertical rod w to be alternately lowered and raised. The rod w is connected to the lower arm of a bell-crank lever x , to the upper arm of which a rod y is connected, while a pendant z , from the rod y , is secured through a slot in the front of the carrying frame with the sliding bar F. The falling and rising movement of the vertical rod w therefore transmits a horizontal motion to the sliding bar F, and the shuttles are caused to move from one holder to another, and back again, on succeeding swivel picks in the manner previously described.

A motion (not shown in Fig. 378) is provided at the driving side of the loom for moving the carrying frame horizontally, so that intermediate figures may be formed. A star-wheel is caused to turn when required by means of suitable connections from the jacquard, and on the boss of the star-wheel a chain barrel is secured which carries a cast-iron chain. This chain is composed of two heights of links, and above—in contact with it—there is a bowl which is supported by a lever fulcrumed at the back of the loom. A high link lifts the front end of the lever, and by means of suitable connections a sliding motion is transmitted to the carrying frame. The next rotation of the star-wheel will bring a small link under the bowl so that the lever will fall and cause the frame to slide in the opposite direction.

Circular-Swivel Mechanism.—A view of a third type of power swivel loom is given in Fig. 379, which, like the last example, is used in producing figures that are placed some distance apart horizontally. As full explanations have already been given of two motions, only certain special features are considered in this case. The loom is made by Schroers, of Krefeld, who have adopted the principle of the American doobby motion for obtaining the principal swivel movements, and

for operating the boxing and picking. Cords from selected jacquard hooks are attached to levers at the top of the loom, and by means of other levers and cords, connections are made at the side of the loom to the vibrating levers of the American motion. By means of the jacquard the centre gear wheels are caused to engage

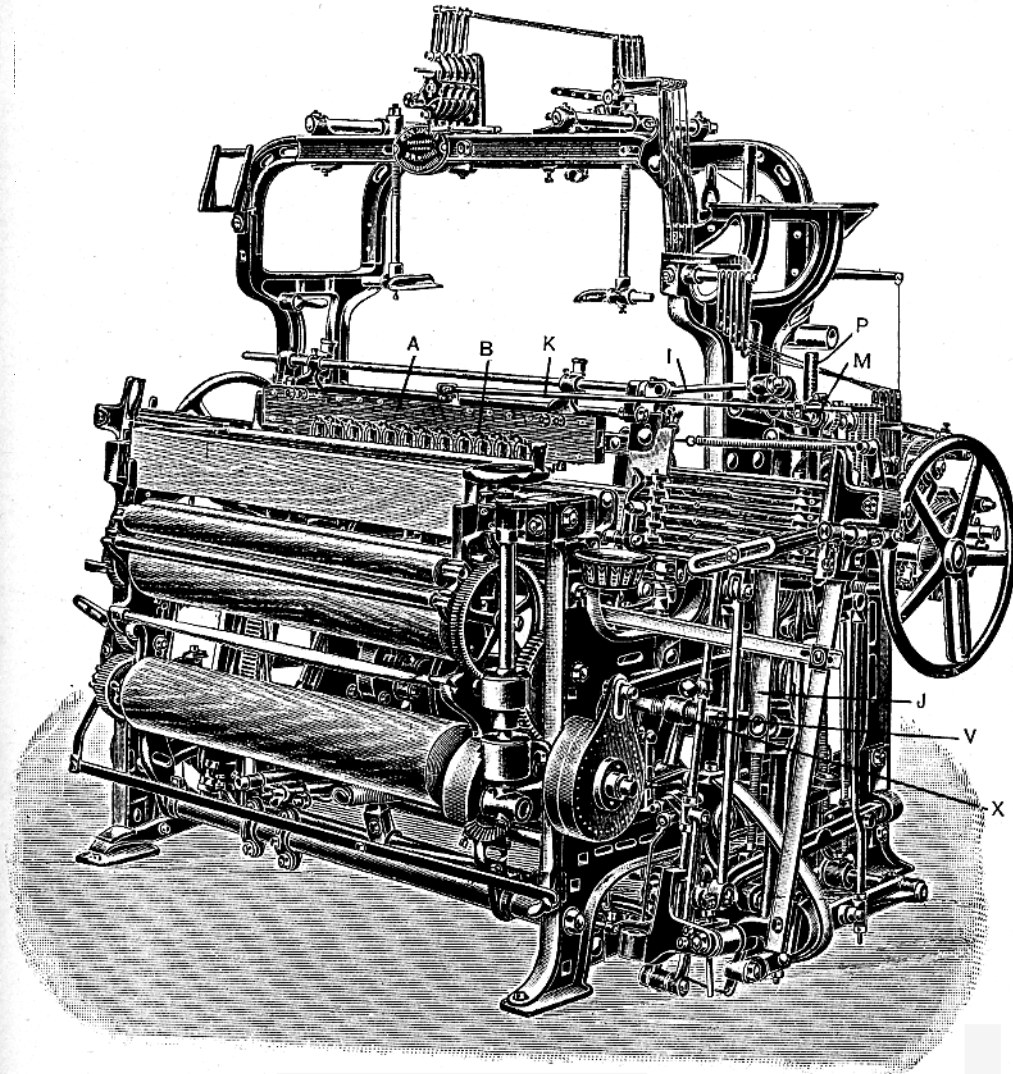

Fig. 379.

with the upper or lower segment wheels as required, and through the connecting bars, levers, etc., the motion is transmitted to the different parts.

Some of the distinctive features of the swivel motion are illustrated by the drawings given in Fig. 380, which correspond with the view shown in Fig. 379, except that the hand of the loom is different. The same letters are used in each

case to indicate the several parts. The swivel shuttles C (shown in the drawings Nos. 1 and 2) are attached by small screws D to the front of the shuttle-holders B, each of which is circular in form and somewhat resembles a horseshoe. The shuttle-holders are contained in circular grooves formed in the carrying frame A, and when the holders are at rest their points are in line with the sides of the recesses that are provided in the lower side of the carrying frame. The warp threads are raised within the recesses, and after the carrying frame has been lowered the circular holders are caused to make a complete revolution. The small shuttles are carried entirely round by the holders, and each inserts a pick of swivel weft below the warp threads that are raised. The holders are rotated in opposite directions on succeeding swivel picks.

The movement is imparted to the swivel shuttles in a similar manner to the preceding example, by means of a longitudinal sliding bar F, the teeth on the lower side of which engage with pinions H. The shuttle-holders B are slotted at the rear so as to form a circular rack E into which the teeth of the pinions H gear, and the parts are so arranged that each pinion operates upon two shuttle-holders, while each holder is engaged by two pinions. The shuttles are thus rotated positively at a constant speed, as when the open space in a circle is opposite one pinion, the movement is continued by the next pinion. The form of the circular rack E is shown in the perspective view given in No. 2, which represents a circle partly revolved.

The carrying frame A is pivotally connected by means of a rod I (shown in No. 3 and in Fig. 379) with the upper end of a vertical rod J, which is fulcrumed at its lower end on a stud J¹ (see No. 4) that is connected to the rocking shaft. The sliding bar F is similarly connected by means of a rod K to a stud L, which is fixed in the slot of a lever M fulcrumed on a short shaft N. The rear end of the shaft N carries a rack wheel O, which is engaged by the teeth of a vertical rack P. The rack P is lowered and raised on alternate swivel picks, and a rotary motion—first in one direction and then in the other—is imparted to the shaft N, and thereby to the slotted lever M. The downward movement of the rack P moves the lever M in the direction indicated by the arrow in the drawing No. 3, and by means of the connecting-rod K a longitudinal movement is imparted to the sliding bar F. The direction of the motion is reversed on the next swivel pick by the upward movement of the rack P. The mechanism can be readily adapted to the formation of the embroidery type of figure in which the swivel weft is floated on both sides of the cloth, as it is only necessary for the circles to be rotated in the reverse direction on the ground picks while the carrying frame is raised clear of the shed.

An interesting method of traversing the carrying frame horizontally is illustrated in the drawings Nos. 4 and 5. Two cords Q from separate jacquard hooks are respectively attached to two levers R and S, the former of which is fulcrumed at R¹, and the latter at S¹. The levers are provided with studs on which are pivoted pendant hooks T, which are retained in engagement with the opposite sides of a peg wheel U by means of a small spring. The wheel U is fixed on the end of a shaft V which passes freely through a slot formed in the sword W. The shaft V is in the form of a worm for about one-half of its length, and this portion gears with the boss X of an arm Y which is connected by means of a stud Z with the vertical rod J. By suitably perforating the cards the shaft V may be rotated in either

direction at any interval through the medium of the levers R and S, the pendant hooks T, and the peg wheel U. According to the direction in which the shaft V is turned, the rod J (which is fulcrumed at J¹) is moved to the left or to the right at its upper end, and through the rod I a similar horizontal movement is transmitted to the carrying frame. The distance that the frame is moved at each lift of a harness

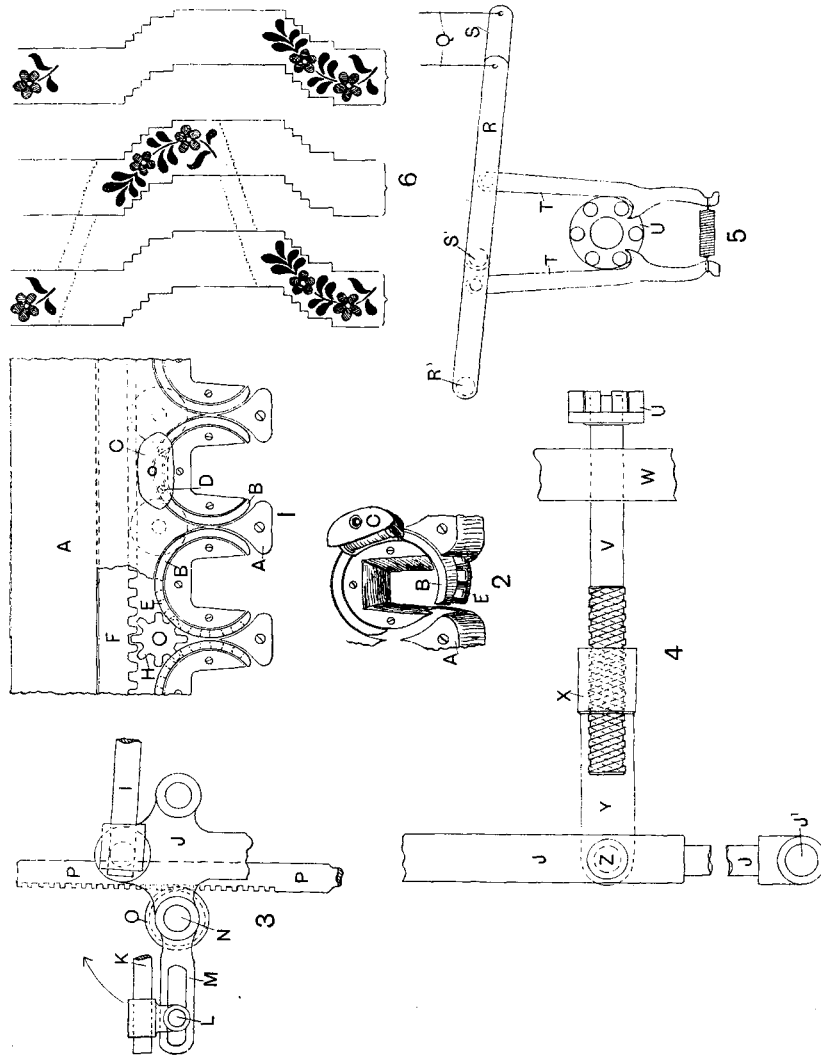

Fig. 380.

cord varies chiefly according to the pitch of the worm on the shaft V, which is generally arranged to impart a movement ranging from $\frac{1}{16}$ to $\frac{1}{8}$ inch.

The chief advantage of this method of traversing the carrying frame is that it enables inclined figures to be formed which extend over a greater space than the width of the recesses in which the warp threads are raised. An illustration

of the form of figure referred to is given in the diagram No. 6 in Fig. 380, in which the bracketed spaces between the vertical lines represent the width of the recesses. Each step of the vertical lines represents a horizontal movement of the carrying frame produced by one lift of a harness cord, and it will be seen that the space between the lines show a slight clearance over the width of the figure in every part. The design is arranged to coincide with the pitch of the circles shown in the drawing No. 1, the width of the repeat being equal to the space occupied by two circles. Each figure is represented as being formed by a separate shuttle, in which case, although all the circles will be rotated at the same time, the swivel yarn will be withdrawn from alternate shuttles only. The frame may, however, be traversed, as shown by the dotted lines, so that the same shuttles may be employed to form intermediate figures.

The diameter of the circles may be varied from 1 to 4 inches and upwards, and the horizontal space between the figures is generally rather less than half the pitch of the circles. As compared with the rack-and-pinion motion, in which the shuttles are moved longitudinally through the shed, the circular type gives greater scope for figuring, as the swivel spots can be formed with less space between; but there is the disadvantage that only one deck of shuttles can be employed. In both systems the swivel weft is withdrawn through the holes in the front of the shuttles, and an important factor, which is common to all types of swivels, is the proper tensioning of the weft so that the formation of curls at the sides of the figures will be avoided. A length of yarn is withdrawn from each shuttle every time the carrying frame is raised above the level of the shed, but by means of a spiral spring (placed on the spindle) upon which the spool exerts pressure as it revolves, the slack yarn is rewound on the spool as the frame descends. The spring is capable of rewinding a length of several inches, and there is, therefore, always a certain amount of tension on the yarn.

CHAPTER XVI

WEFT PILE FABRICS

Formation of Weft Pile. *Plain Velveteens*—Tabby or Plain-back Velveteens—Length of the Pile—Density of the Pile—Changing the Density of the Pile—Fastness of the Pile—Twill-back Velveteens—Designs which simplify the Cutting Operation. *Corded Velveteens*—Corded Velveteen Cutting—Corded Velveteens from Plain Velveteen Weaves—Particulars of Weft Pile Fabrics. *Weft Plushes*. *Figured Weft Pile Fabrics*—Figured Velveteens—Figured Cords. *Imitation Weft Pile Fabrics*.

IN pile or plush fabrics a proportion of the threads—termed pile threads—project from a foundation texture and form a nap or pile on the surface. In some classes of the cloths the pile threads are cut and the surface of the cloth is then composed, where the pile is formed, of the free ends of the fibres which, in many cases, gives an appearance closely resembling fur. In other plush fabrics the pile threads are not cut, and the pile surface then consists of small loops or curls. The pile threads may be introduced as weft forming weft pile fabrics, in which the pile is invariably cut, or as warp forming warp pile fabrics, in some of which all the

pile is cut, and in others all looped ; while in certain textures a combination of cut and looped pile is produced.

Formation of Weft Pile.—Weft pile cloths are composed of only one series of warp threads, but the weft threads, so far as regards the system of interlacing, are in two series, namely, ground and pile. The ground picks interweave frequently with the warp so as to form a firm foundation, while the pile picks float somewhat loosely on the surface, and subsequently form the pile or nap.

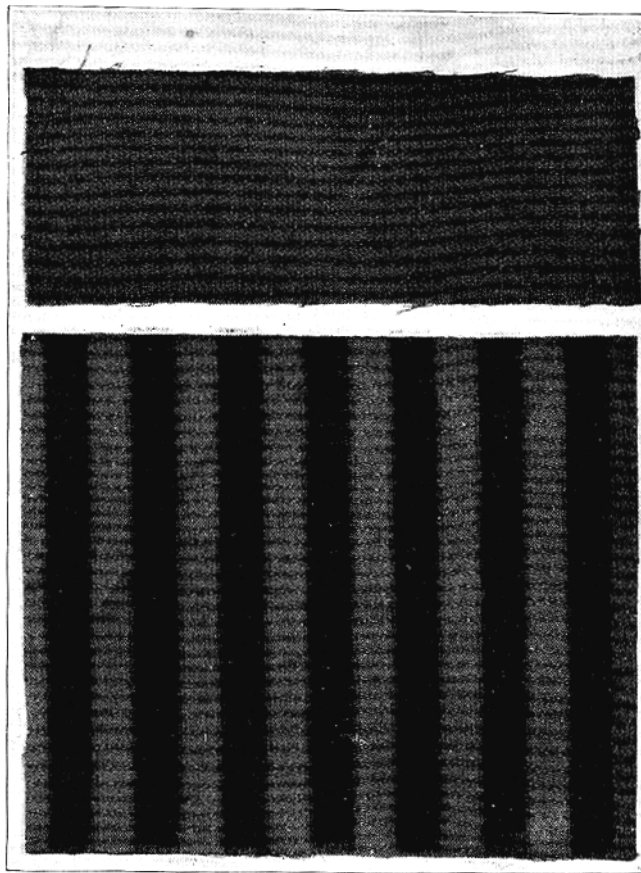

Fig. 381.

The textures are produced in the loom in the same manner as ordinary fabrics, and after weaving appear similar except that the surface of the cloth is densely crowded with the floating picks of weft which are to be cut to form the pile. The cloths on the underside show a plain rib or fine twill effect, according to the kind of ground weave that is employed. The appearance of a cloth in both the cut and the uncut condition is represented in the lower portion of Fig. 381. The dark sections show where the pile has been cut, but the light sections are uncut, and the latter indicate how the whole face of the cloth appears before the cutting opera-

tion. The example does not illustrate the usual appearance of a weft pile texture,

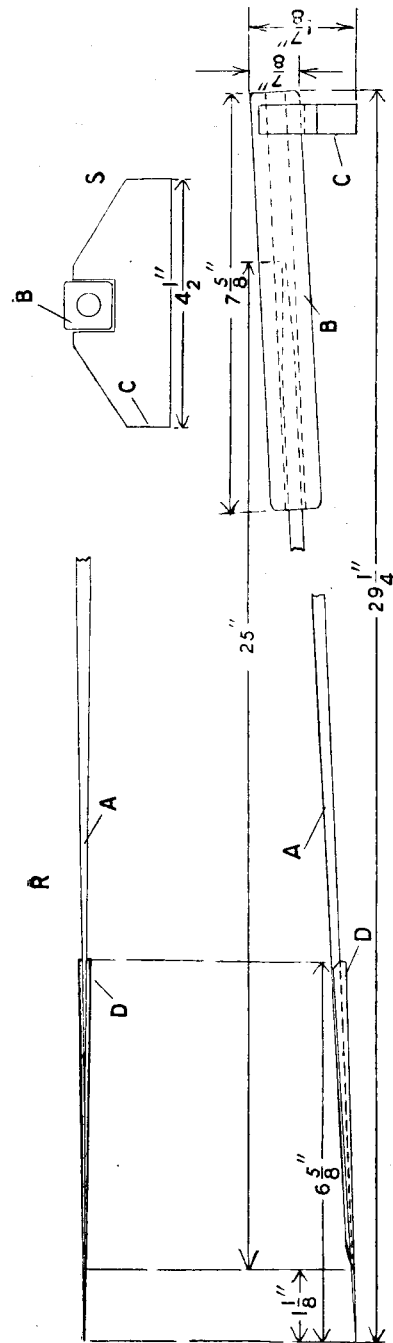

Fig. 382.

as in this instance the idea has been to produce a variation from the ordinary type of cloth by forming stripes of pile $\frac{1}{4}$ inch wide with equal uncut spaces between. The upper portion of Fig. 381 represents the appearance of the under side of the cloth, the foundation weave being the 1-and-2 twill.

The formation of the pile is a part of the finishing process in which the floating pile picks are cut by means of a specially shaped knife—provided with a guide—which is run lengthwise of the cloth on its surface. The form of a cutting instrument is illustrated in Fig. 382, in which a front elevation is shown at P, an end view of the rear portion at S, and a plan of the cutting end at R. The dimensions indicated on the diagrams correspond with an example, but the size is varied according to requirements.

The knife A is a steel rod which, for the greater part of its length, is about $\frac{1}{4}$ inch square. The rear extremity is roughly pointed in order to facilitate its insertion in a removable wooden handle B, which has a circular hole bored throughout its length. The rear end of the knife is packed with cotton waste or other material in order to make it fit tightly within the circular hole, and it is pushed a greater or less distance within the handle in order to vary the length of the instrument. The handle is adjustably attached to a piece of wood C, which rests on the cloth and raises the rear end of the knife so that it is retained at a suitable angle during the operation of cutting. Usually the rest C is placed at the rear of the handle B, but if required it can be attached nearer the centre.

Towards the cutting end the knife is tapered, and for about 3 inches from the extremity it is made in the form of a narrow flat blade with a very sharp

upper edge. The keenness of the blade is maintained by frequent grinding. This end of the knife is inserted in a removable metal sheath D, which terminates in a very fine point and acts as a guide. The upper edge of the blade rises above the edges of the sheath, and the object of the latter is to steady the thin blade, to guide it along the proper course, and to pass with its point under the floating picks and bring them into contact with the cutting edge.

Previous to the cutting operation the pile side of the cloth is passed in contact with the upper surface of a roller which revolves partly immersed in slaked lime contained in a suitable receptacle. A thin coating of lime paste is applied to the surface of the cloth, which is then dried by being passed in contact with hot cylinders. Subsequently, the cloth is further stiffened by the application of a coating of flour paste to the under side, and drying again follows. The purpose of the second application is to fix the pile weft threads in the cloth so that they will not be pulled out as the operation of cutting proceeds.

A length of the prepared cloth is stretched very tightly in a frame, and the operative runs the knife over its surface in the direction of the length. The finely pointed guide passes under the pile floats which are in line with its movement, and brings them into position for being cut by the blade. Successive traverses of the knife are made until the length under treatment is completed; then this portion is wound upon a beam and the next length of cloth operated upon. The process is repeated throughout the length of the piece. The cutting may be performed on short or long frames, the former taking from $1\frac{1}{2}$ to 2 yards of cloth at a time, and the latter 9 or 10 yards.

The accurate joining of the cutting courses is a very important matter, as a defect will show at these places in the finished cloth if there is any irregularity. For this reason the long frame system is usually considered the better, because there are fewer places where the defect can occur. In the short frame system the operative cuts one cloth at a time, but in cutting long lengths two cloths, in adjacent frames, are treated. The operative walks between the two frames and cuts a course in one cloth while passing in one direction and a course in the other cloth on his return. The process is very tedious as from 700 to 1,000 longitudinal strokes of the knife may require to be made at each length in cutting across a width of 24 inches of cloth.

On the completion of the cutting operation the stiffening substances previously applied are removed by scouring, and the cloth is then dried. If any holes have been made during the cutting they are repaired by sewing the sides together with a fine needle. A wire is then laid on the cloth in line with the place, and a thread, similar to the weft, is stitched into the foundation and wrapped round and round the wire. After the withdrawal of the wire the loops are cut and the free ends evened by means of fine scissors.

A process of brushing follows the drying in which the pile surface is operated upon by flat brushes which work across the piece in opposite directions, and then by circular brushes. Afterwards superfluous fibre is removed by cropping or singeing; in the latter process the pile surface is passed lightly in contact with hot plates. In a good quality of cloth brushing and singeing may be repeated several times. After the singeing, the cloth is a brown or ecru colour, and if required to be dyed a light shade it is bleached.

In the dyeing process, the cloth is first treated in the ordinary manner, so that