

## CHAPTER 7 WEAVING

### 7-1. General.

Weaving is a popular craft with both men and women. It can be simple or complicated, requiring very much or little concentration. It can be very fatiguing or slightly tiring. It can require motion of the entire upper extremities and much of the lower extremities, or it can require limited motion of only the upper extremities.

### 7-12. Types of Looms.

#### a. Table Looms.

(1) Two-harness table looms (Peacock looms) are light and portable (fig 7-1). They are simple and uncomplicated to operate. The weaving width ranges from 12 to 16 inches (30 to 37 mm).

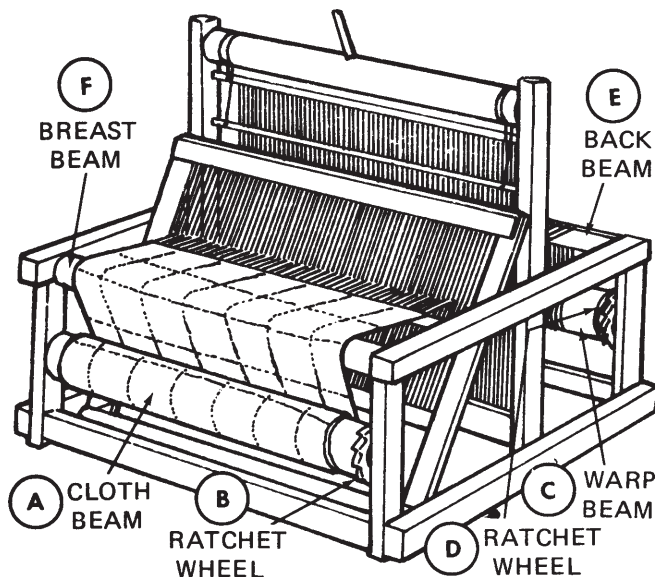

Figure 7-1. Peacock table loom.

(2) Four-harness table looms (fig 7-2), which are heavier than Peacock looms, are operated by hand levers which are depressed to change the shed. Hand-treading looms should be of the type which can be easily changed from right-hand to left-hand treading. The weaving width usually ranges from 16 to 24 inches (37 to 60 cm).

b. *Floor Looms.* Floor looms (fig 7-3 and 7-4) are commonly available with either two or four harnesses. They may have as many as eight harnesses. The four-harness loom is more versatile, as it affords activity which ranges from simple to complex. All brands of floor looms are basically very similar.

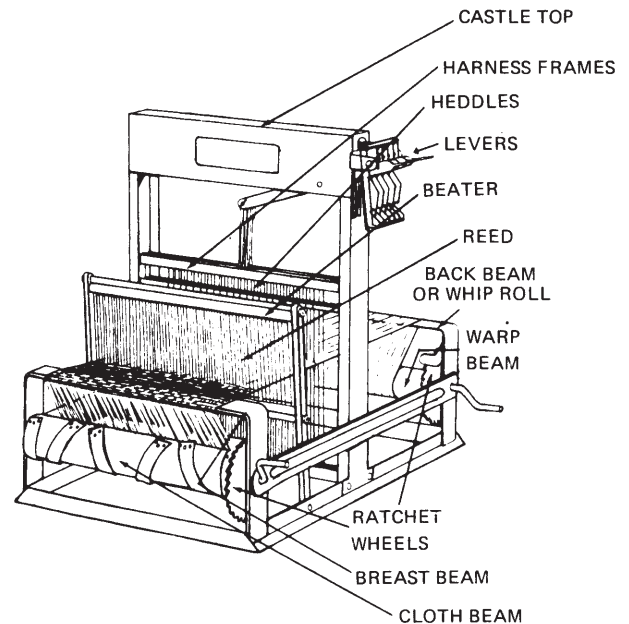

Figure 7-2. Four-harness table loom.

### 7-3. Terms Used to Identify the Parts of a Loom and the Thread

#### To Be Woven Into Cloth

To understand the processes involved in weaving, one must first become familiar with the terms used to identify the parts of a loom and the thread to be woven into cloth. For definitions of other weaving terms, reference is made to paragraph 7-15.

a. *Web*—Web is cloth woven on a loom from threads extended lengthwise (warp) and crosswise (weft). As the web is woven, it is wound onto the cloth beam (A) of fig 7-4) by use of the ratchet wheel (B).

b. *Warp*—Warp refers to the threads which are wound onto the warp beam (C) of fig 7-4), threaded through the loom, and tied to the apron which has been made of cloth (usually canvas) and attached to the cloth beam. The warp is moved through the loom by adjusting the ratchet wheels (B) and (D).

c. *Weft or Woof*—Weft (woof) refers to the threads wound on shuttles (fig 7-5) and passed by hand crosswise of the warp, thus forming web (cloth).

d. *Tabby Thread*—The tabby thread is wound on a shuttle (fig 7-5) and passed by hand crosswise of the warp alternately with the shuttle of weft (c above) to hold threads forming the pattern in place. Tabby thread is thinner than weft so that the pattern will dominate.

e. *Beams*—The beams (fig 7-4) are parts of the loom that hold or support the warp and the web. The warp

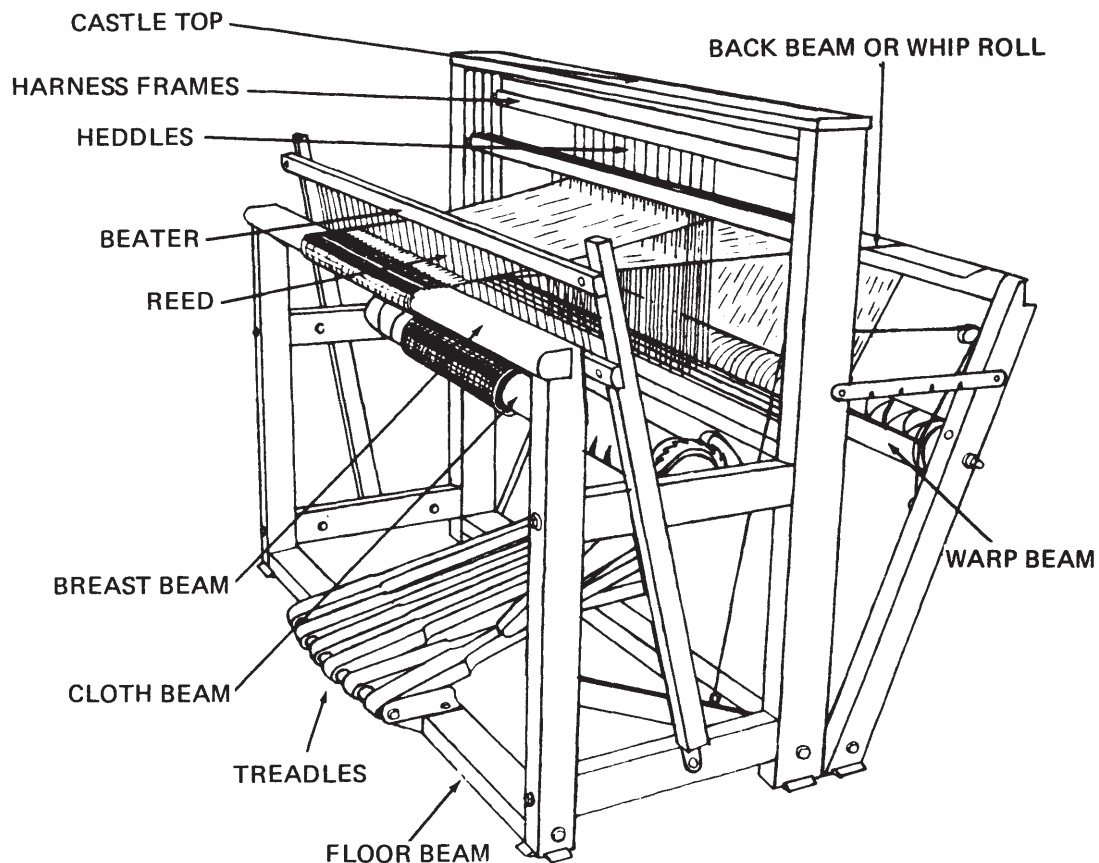

Figure 7-3. Floor loom.

wound onto the warp beam (C) is supported by the back beam (E) as it enters the loom. The web is supported by the breast beam (F) as it is woven and rolled onto the cloth beam (A).

*f. Harnesses*—A loom may have two to eight harnesses. The particular weaves which can be produced depend upon the number of harnesses with which the loom is equipped. A harness (G - I) of fig 7-4 is made of a frame, heddle rods, and heddles with eyes through which the warp is threaded. The heddles may be made of wire, string, or flat pieces of thin metal.

*g. Heddle Horses*—The heddle horses (J) of fig 7-4 are rods hung from the castle top (K) to support the harnesses and keep them in alinement.

*h. Treadles*—The treadles (L) of fig 7-4 are foot peddles used to raise and lower the various harnesses in a specified sequence to produce a particular pattern in weaving. Table looms have hand levers for raising and lowering the harnesses.

*i. Lams*—The lams (M) of fig 7-4 are horizontal levers attached to the side post (N). The lams connect the treadles to the harnesses and aid the treadles in bringing the harnesses down evenly.

*j. Beater*—The beater (O) of fig 7-4 is the frame that holds the reed (sley) (P). Each single space within the reed is a dent (Q) through which a thread is passed as it runs from the warp beam and through the heddles to the cloth beam. The reed is used not only to keep the warp threads equally spaced and in alinement but also to beat the weft into place as the beater is pulled forward.

*k. Shed*—The shed is the horizontal opening (fig 7-6) made by separation of warp threads. The threads are separated by pressing one or more threads, thus lifting one or more of the harnesses containing the heddles of warp threads. The shed is the opening through which the shuttle is passed to deposit a weft thread.

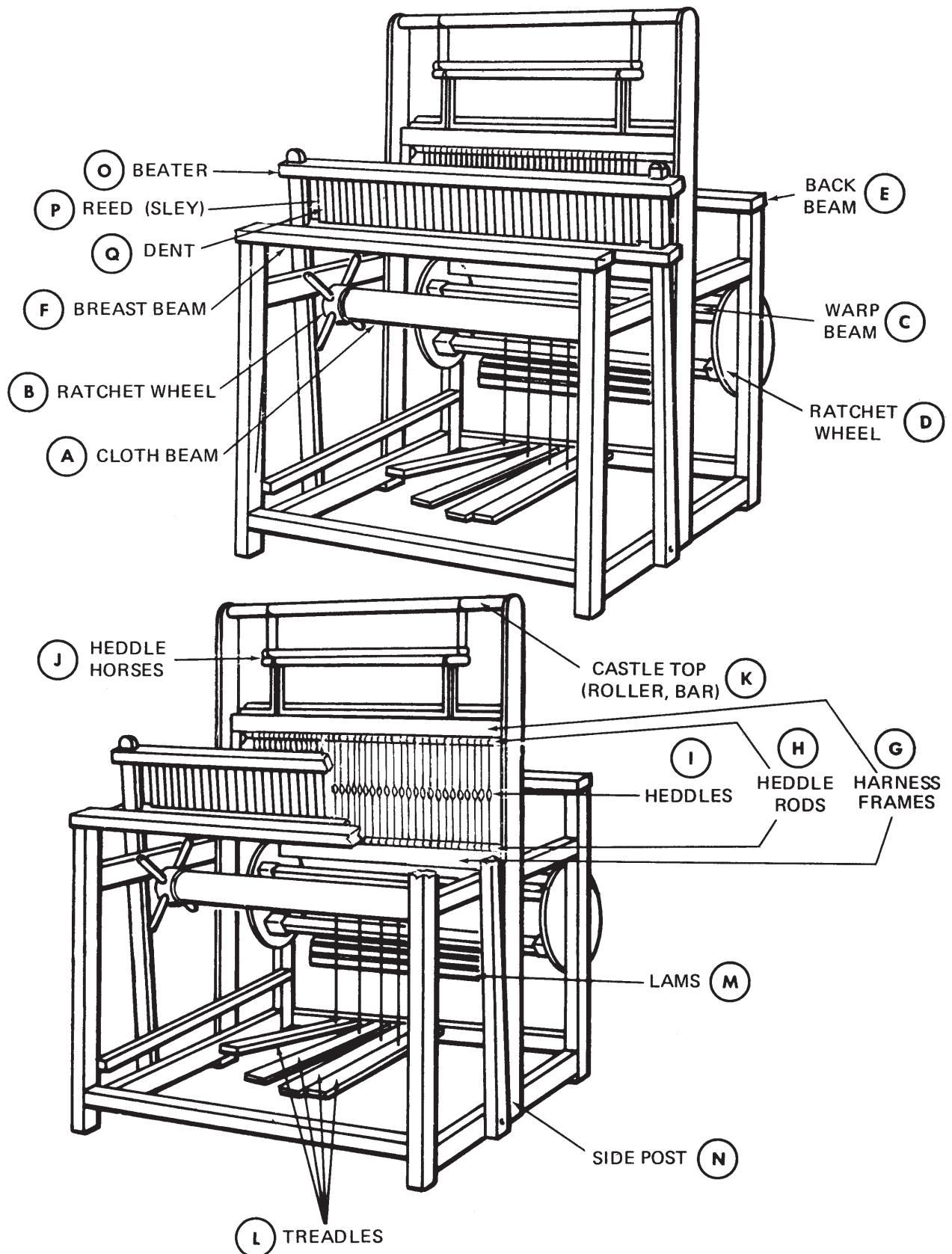
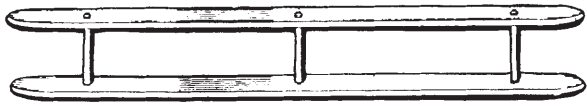

Figure 7-4. Floor loom with cutaway view.





RUG TYPE



FLAT TYPE

Figure 7-5. Shuttles.

#### 7-4. Operation of the Loom.

Here are three basic steps in weaving fabrics on a loom. First, certain treadles are depressed to form the shed of warp threads. Secondly a weft thread is put into the shed by running the shuttle through the shed. Thirdly, the beater is pulled, thus pushing the weft thread into place. These steps are repeated until the desired length of fabric has been woven.

#### 7-5. Plans for Weaving Article

a. *Choosing an Article.* Many articles may be woven on a loom. The beginner should choose a small article, such as a scarf, sash, place mat, finger towel, or small rug.

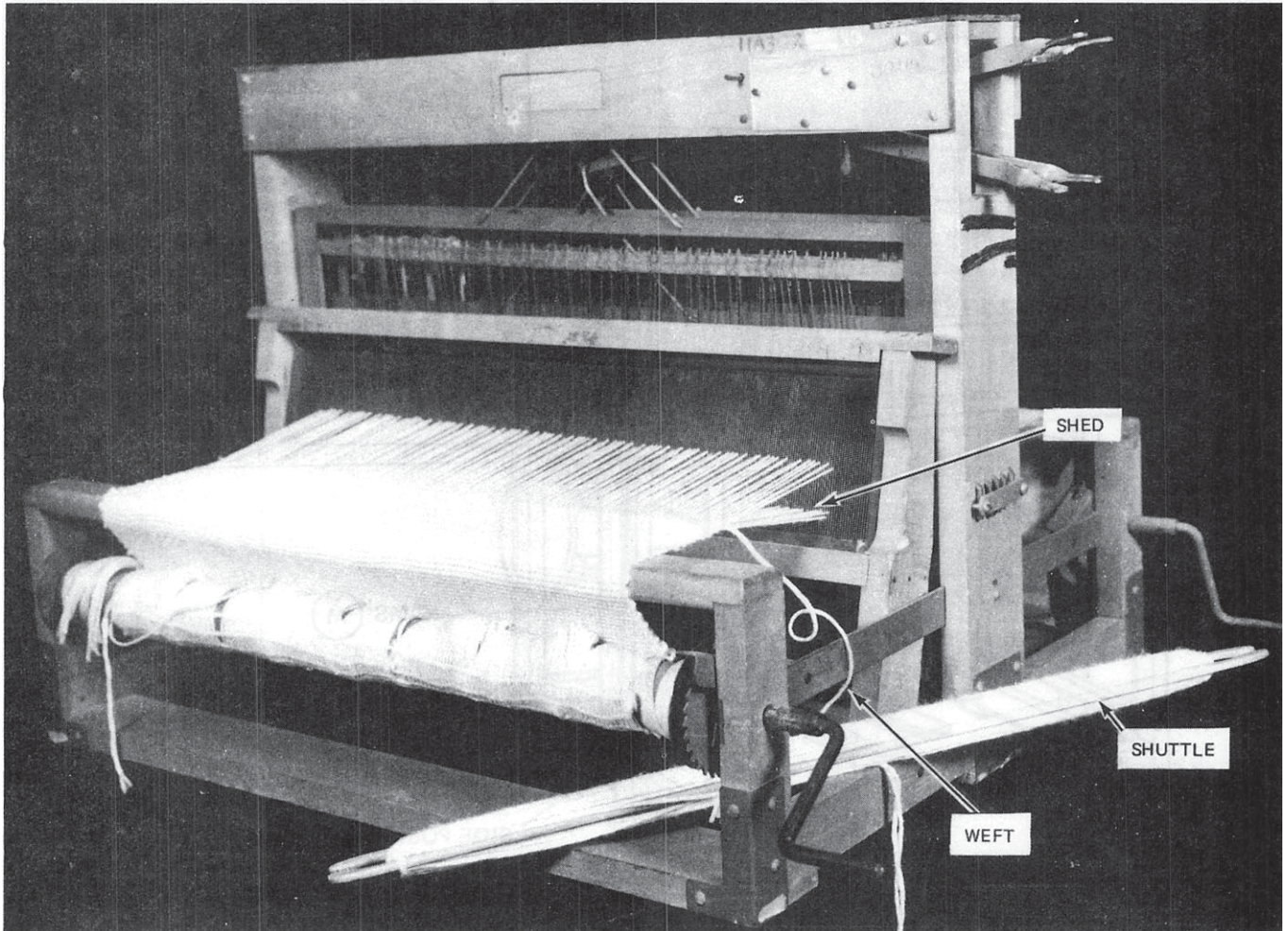

Figure 7-6. Shed through which the shuttle of weft is passed.

*b. Selecting the Yarn.* The selection of weight, type, and color of yarn for weaving depends upon the proposed use of the finished article.

(1) *Cotton.* Cotton yarn is used extensively in weaving because it is washable, durable, and easy to manage.

(a) The four-ply heavy cotton thread, which may be purchased in 4- or 8-ounce (112 to 224 gram) tubes is a carpet warp. Finer cotton yarn or thread for other uses comes in sizes 20/2, 24/3, et cetera. The upper part of the fraction refers to the size of the thread; this number becomes larger as the thread becomes finer. The lower part of the fraction refers to the ply which means the number of strands in a cross section of the yarn or thread.

(b) It is possible to purchase spools of machine-wound warp. These spools can be slipped onto a rod of the warp beam of a four-harness table loom (fig 7-2). This warp is available in white and natural and in fine sizes as well as in the heavy or carpet weight. A spool of fine warp has 60 ends; each will extend 20 yards (18 m). Spools of carpet warp have 30 ends; each will extend 10 yards (9 m). The fine warp is not practical for a busy clinic. The machine-wound carpet warp is expensive.

(c) Roving which is a three- or four-ply soft cotton yarn is often used as weft in weaving rugs. It comes in a variety of colors and is usually purchased in 1/4-pound (112-g) skeins.

(d) A knitting and crochet four-ply cotton yarn, about the diameter of wool worsted, is frequently used as tabby thread. It is available in a variety of colors and in 100-yard (91-m) skeins with 12 skeins per box.

(2) *Wool.* Four-ply worsted wool is used for afghans and wool scarves. Wool tends to be sticky when it is used as a warp, thus causing the shed not to be completely clear. The finer wools are difficult to use for both warp and weft, but they make handsome pieces when they are used as weft with cotton warp and tabby.

(3) *Linen.* Linen thread makes nice finger towels, place mats, and dresser scarves. The largest linen thread is No. 1; the smallest is No. 40/2. Linen thread is available for use as warp and weft. Linen warp can also be used for weft; but linen weft cannot be used for warp, as it is not strong enough to tolerate the tension of the loom.

(4) *Synthetics.* Nylon and orlon yarns are easier to use as warp than 100 percent wool. Metallic and other novelty materials may be used as weft to give a dramatic effect. They are not suitable for warp, as they are uneven and weak and stretch easily.

*c. Choosing the Weave or Pattern.* A small piece such as a purse, place mat, or dresser scarf is usually more pleasing when it is woven in a small pattern. Bedspreads and rugs look nicer in large patterns. The size of the pattern is determined by the number of

threads in the pattern. There are endless pattern varieties, depending upon the sequence in which the warp is threaded through the heddles and the way the pattern is treadled. The techniques and patterns available can be combined in so many ways that some persons have devoted a lifetime to seeking and developing them.

(1) *Plain or tabby weave and variations.* This is the simple over-and-under weave (fig 7-7) such as the one used in darning a sock. Only two harnesses are required in weaving this pattern; however, more than two harnesses may be used. If four harnesses are used, the over-and-under weave can be varied by warping the loom in colors to form the twill pattern (fig 7-8). Although a patient may be somewhat confused, he can weave this simple, repetitive pattern. The hound tooth pattern (fig 7-9) is another interesting variation of the plain weave. The honeysuckle pattern (fig 7-10), which is only 26 threads wide, is a small pattern that can be repeated several times, even on a small piece.



Figure 7-7. Two-harness plain or tabby pattern.

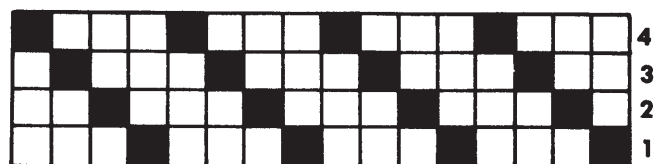

Figure 7-8. Four-harness twill or tabby pattern.



Figure 7-9. Hounds tooth pattern.



Figure 7-10. Honeysuckle pattern.

**FM 8-1**  
**AFM 160-35**

(2) *Plaid weave.* Plaids, which are usually woven with two harnesses, are often more interesting and stimulating to patients than the plain weave. The key to weaving plaids is color and sequence.

(3) *Patterns.* Weaving patterns are set up on graph paper with each row representing a harness

frame and each block representing a heddle (fig 7-7 – 7-10). Graph patterns are read right to left. Row 1 on the graph paper represents the harness frame No. 1 which is nearest the breast beam. Row No.2 represents frame No. 2, et cetera. Some of the plaid patterns used in occupational therapy are illustrated in table 7-1.

*Table 7-1. Patterns For Authentic Scotch Tartan Plaids.*

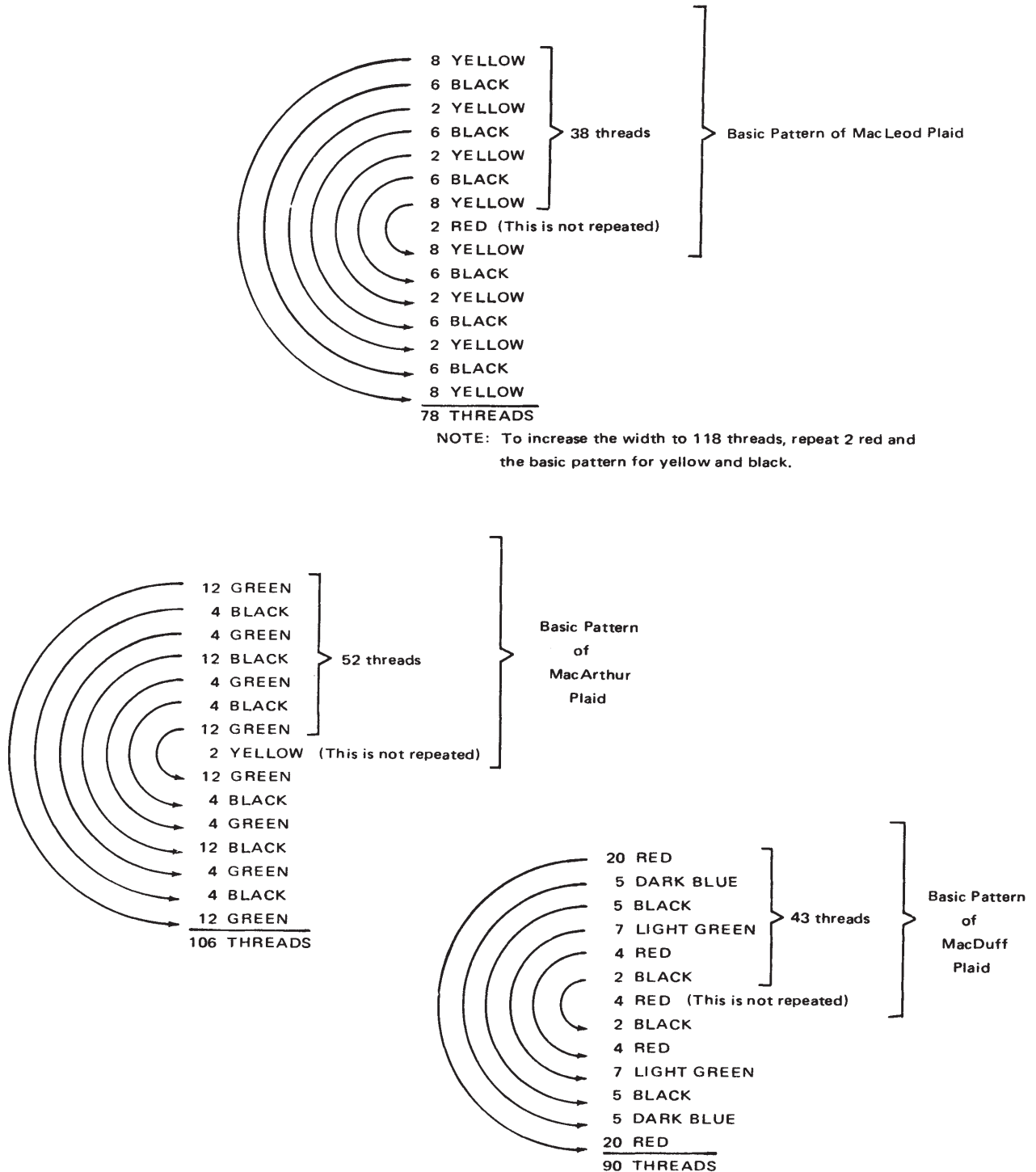

*Table 7-1. Patterns for Authentic Scotch Tartan Plaids.*



*d. Adapting the Pattern to the Loom.*

(1) The pattern must be kept balanced so that both sides of the cloth look the same as illustrated in table 7-1. If additional width is desired but the loom will not take the number of threads required to repeat the basic pattern again, the pattern may be altered by decreasing the number of threads throughout the pattern. After a pattern of an authentic plaid is altered, it becomes an adaptation of that plaid. The pattern may be adapted to the loom by adding only a part of the pattern to each side; however, care must be taken to make both sides symmetrical.

(2) The number of times a pattern can be repeated, as well as the texture of the finished cloth, depends upon the number of dents per inch in the reed, which is the comblike device in the beater (para 7-3j). The number of dents per inch is stamped on one end of the reed. If there are only a few dents per inch, the warp threads will be spread far apart; and the woven cloth will be coarse in texture. If there are many dents per inch, the texture of the cloth will be close and fine in texture. If the reed is coarse but a rather fine cloth is desired, two threads can be put through each dent.

(3) A pattern is adapted to the loom as illustrated in the following example:

(a) Multiply: 35 inches (desired width of finished cloth) x 15 (number of dents per inch in the reed) = 525 (total number of threads required).

(b) Divide: 525 (total number of threads required) divided by 75 (number of threads in the pattern) = 7 (times which the pattern must be repeated).

(c) If the pattern is, for example, 60 threads wide, it could be repeated 8 times with an additional 45 threads needed to make the finished cloth 35 inches (87.5 cm) wide. It is possible to add a part of the pattern on each side to accommodate the threads needed. Care must be taken to make both sides symmetrical.

(d) Two threads should be allowed on each side for selvage. A selvage, which is woven in the tabby weave, prevents the edge from drawing during the weaving process.

*e. Planning Borders.* Borders enhance the beauty of hand-woven articles; however, they are not essential.

(1) A horizontal border, woven across the warp at each end of the web or at intervals of its entire length, is the most common type of border. It is easy to plan and weave.

(2) A vertical border, woven as a vertical column along the right and left selvages, requires plans for the border threads.

(3) Any pattern in the same weave as the planned article may be used as the border. A small, simple figure usually makes the most attractive border. If the main pattern is a small figure, a large, elaborate border pattern may make the article more attractive.

**7-6 Preparation of the Loom for Weaving.**

After the weaving pattern has been selected and adapted to the loom, the loom is dressed with either sectional beamed warp (para 7-7) or with chained warp (para 7-8). The weft and tabby thread are then wound onto the appropriate shuttles (para 7-9), and the loom is adjusted (para 7-10). Each process must be accomplished precisely and checked carefully to prevent errors which are difficult to correct after the weaving process is started. Additional methods of identifying and correcting errors are provided in paragraph 7-12.

**7-7. Dressing the Loom With Sectional Beamed Warp**

*a. Sectional Beaming of the Warp.*

(1) Sectional beaming is the process used in winding warp directly onto the warp beam from spools, which have been placed on a spool rack (fig 7-11). When winding very long, wide warp such as that for a rug, this process is especially advantageous. Weaving consumes most rug warp rapidly. With a large turnover of patients in the occupational therapy clinic, it is helpful to wind long length of warp onto the large floor looms. Today, many looms are equipped with the sectional warp beam. Moreover, it is a simple matter to convert the ordinary warp beam into a sectional one with equally spaced dowels. The dowels or pegs are set equal distances along the beam. The warp lies in these sections instead of being spread evenly along the entire beam. If sectional beaming is properly done, it is a distinct timesaver. The only disadvantage is that it sometimes requires as many as 40 to 60 spools of warp of one size and color. Unless a number of articles are to be woven with the same warp, the financial outlay is considerable. The total yardage of all the spools is not required for a single warping of a loom. The spools may weigh 2 to 8 ounces (56 to 224 g). Cones cannot be used satisfactorily, as warp does not pull off a cone shape easily.

(2) Sectional beaming is accomplished as follows:

(a) Identify the dent at the center of reed. If this dent is not already marked, tie a piece of colored thread to it. The center dent can be located in a number of ways. One way is to multiply the number of dents per inch (stamped on the reed) by the length of the reed, excluding the flat piece on each side, then divide this total by two.

(b) On each side of the center dent, identify the dent to which the warp must extend to make the woven cloth the desired width. This is accomplished by measuring from the center to the left a distance of half the width of the cloth to be woven. Measure the same distance to the right. Mark these dents by tying pieces of colored thread in them.

(c) Extend a long piece of thread through each of the two outer marked dents; then tie one end of the thread onto the breast beam and the other end to the

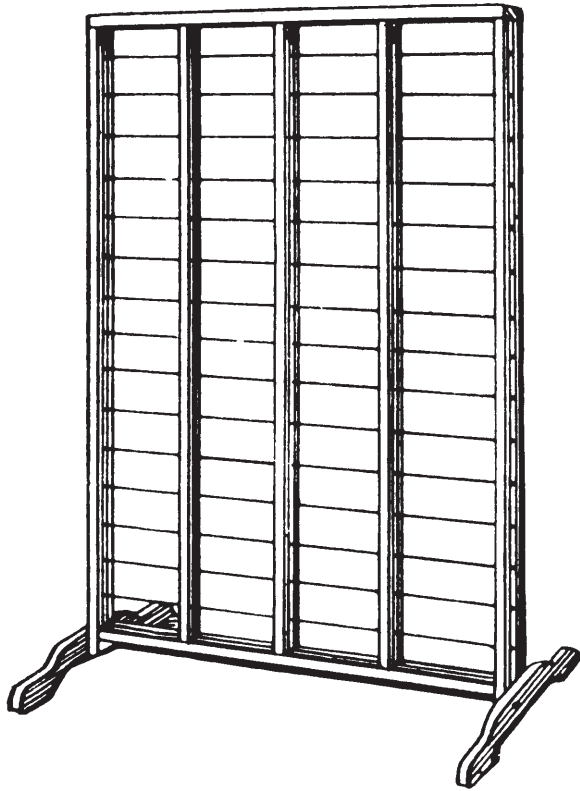

Figure 7-11. Spool rack.

warp beam, insuring that it runs in a perfectly straight line. These threads must not run at an angle. They identify the total space on the sectional warp beam within which the warp will be wound as well as the space on the cloth beam within which the warp will be tied after it is threaded through the loom.

(d) Determine how many threads are to be wound in each section on the warp beam. This is accomplished by dividing the total number of threads required for the cloth (para 7-5d (3)) by the number of sections within the marked space. If the total number cannot be divided equally, it will be necessary to place one or two more or less threads in some of the sections.

(e) Determine the length of a thread consumed in one full round of the warp beam to provide a means for measuring thread as it is wound into each section. The thread in all sections must be the same length; otherwise, all threads longer than the shortest length will be wasted. To insure accurate measurements, the weaver should train himself from the beginning to start and stop the warp beam at some specified place, such as when the handle is at the bottom of the turn.

*NOTE:* A loom that comes equipped with a sectional warp beam usually has a roller which is one yard around and a gauge which measures yardage.

(f) Place the spools of thread in the desired colors on the spool rack (fig 7-11). One spool is required for each thread required in the sectional warp. All the thread ends must come from the spools in the same direction, preferably from under the spool. If possible,

place spools on every other row on the spool rack and allow the thread to pass under the empty rod below. If this is not possible, push each spool to one side and allow the thread to pass under the empty portion of the rod below. Care must be taken to avoid any twisting. The spool rack should be positioned 4 feet (120 cm) from the back of the loom.

(g) Secure the tension box (fig 7-12) in position on the back beam. Starting with the top spool of thread on the left-hand side of the spool rack, thread the ends through the tension box. The "over and under" and "under and over" threading through the tension rods should be alternated. Be careful to take the thread ends in order and to avoid crossing them. If they are crossed, they will break during the winding. When this process is finished, the threads will be in the same order as they are on the spool rack. If a tension box is not available, a guide plate may be used. This is a metal plate filled with holes through which the threads ends are pulled. It is fitted into a slot on the back beam.

(h) Tie the warp to the section of the warp beam to be wound first. There is no rule specifying the section which should be filled first. This is sometimes governed by the colors being used. To prevent undue stress on the warp beam, it is advisable to wind the first section, then the last, alternating back and forth until all sections are filled. Tapes or cords may have been secured to sections of the warp beam for tying purposes. Those tapes not to be used should be secured in place before starting the winding process. The method for tying warps to another object is illustrated in figure 7-13.

(i) At this point, check the direction in which the warp beam should be turned so that the dog will engage correctly in the ratchet wheel to hold the warp at a tension. Some beginners have had the misfortune to turn the warp beam in the wrong direction for the entire winding; others have wound various sections in different directions. Such errors complicate the process considerably and necessitate rewinding the warp.

(j) Determine the number of turns which must be made to put the required length of warp onto the beam (e above); then begin the actual winding of the warp onto the beam. Take care to insure that the threads are spread evenly in the section and not piled up near the pegs or in the center. If a very long warp is being wound, it is wise to pound the wound warp gently with a mallet after each 10 to 15 turns to be certain it is not piling up (fig 7-14).

(k) After the required number of turns have been made and the first section has been filled, keep the threads taut and place one piece of masking tape across the threads near the warp beam to keep them in the same order in which they came from the tension box and another piece across the thread near the ten-



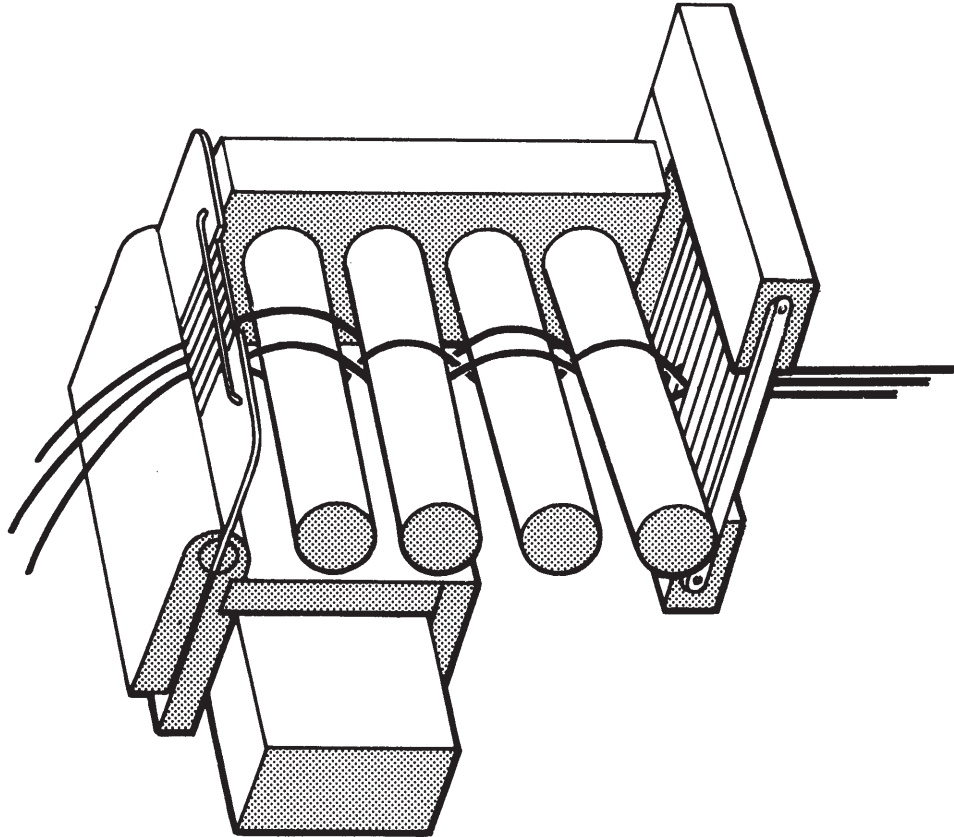

Figure 7-12. Tension box showing threading.

sion box to prevent the box from becoming unthreaded when the cut is made. Cut the warp above the tape near the beam and secure it to the wound section with another piece of tape.

(1) Prepare to wind the next section by tying the warp ends coming from the tension box to another section of the warp beam. Wind this section and proceed until all sections have been wound; then secure the beam with the ratchet to keep it from turning. The loom is now ready to be threaded and sleyed.

*b. Warping the Loom With Sectional Beamed Warp.* When warping the loom with warp that has been beamed (rolled onto the warp beam), the loom is sleyed and sleyed from back to front; otherwise, the loom is sleyed and threaded from front to back (para 7-8). The aim of warping the loom is to have each thread follow the route shown in figure 7-15.

(1) *Threading the loom.* Threading is the process of putting the warp threads through the heddles in a sequence to produce the desired pattern.

(a) With the warp ends still secured with tape, unwind the warp two turns of the warp beam and maintain tension on the warp. Lay the warp over the

back beam, letting it extend beyond the beam 1 to 1 1/2 yards (.9 to 1 m) for threading through the heddles; then tape the threads in order across the back beam.

(b) With row No. 1 on the weaving pattern graph (para 7-5c(3)) representing the harness frame nearest the breast beam, check each harness frame against the pattern graph to insure that it has one heddle for each thread. If required, insert additional heddles. If the frame contains too many heddles, either remove the excess ones or place half of them on one side and half on the other side to keep the harness from hanging unevenly.

*NOTE:* A very close weave may require two threads per heddle.

(c) Thread the warp through the heddles by reading the pattern graph (fig 7-16) from bottom to top and from right to left as follows: Insert the first thread of the warp through the eye of the first heddle of harness frame No.1. Insert the second thread of the warp through the eye of the first heddle of harness frame No. 2. The pattern graph is followed until all the warp is threaded. Use the sley hook (fig 7-17) with the slot side down to thread the heddles. The easiest way to thread the heddles is to use two persons.

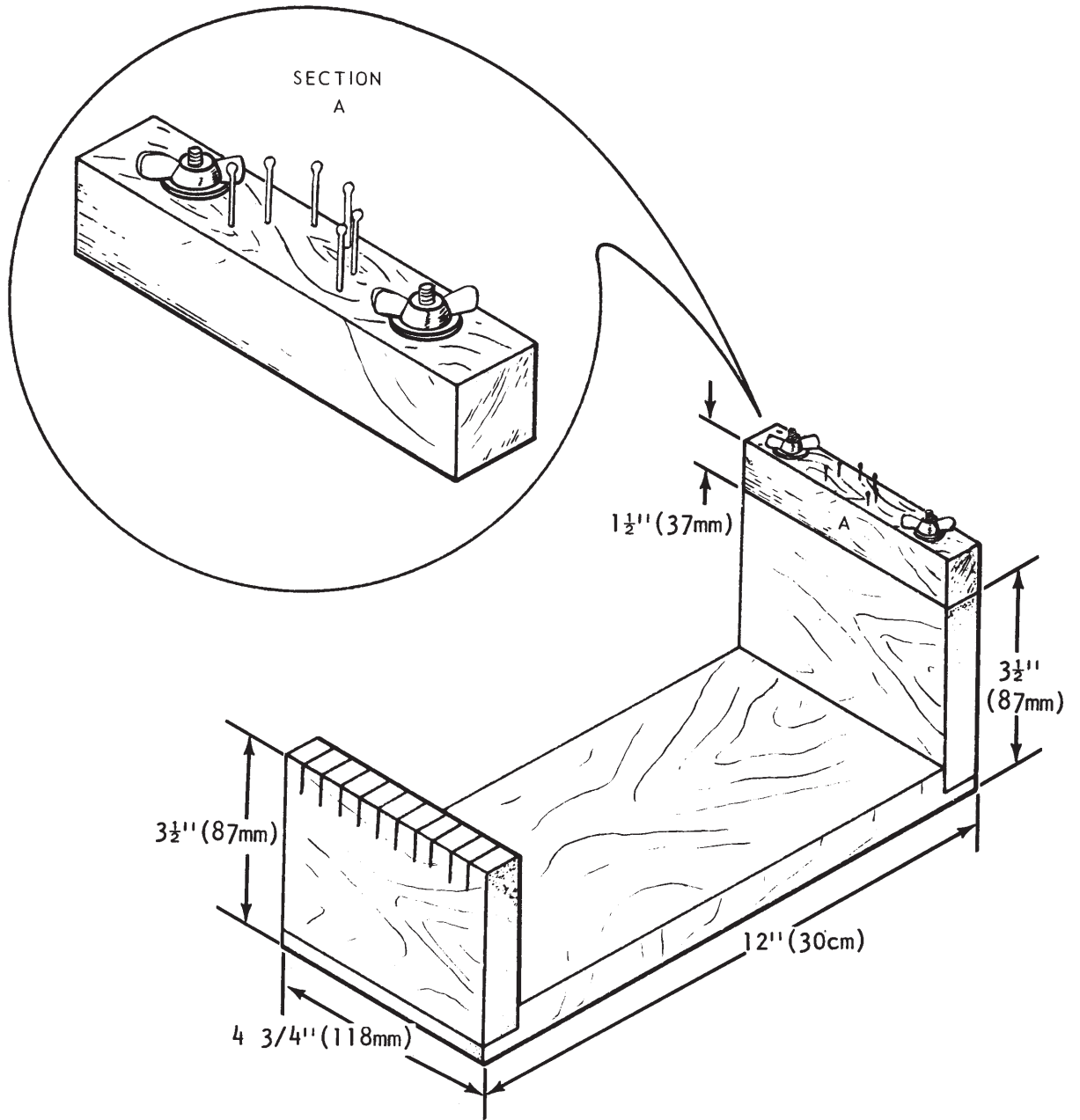

Figure 7-13. Steps in tying warp to apron or rod.

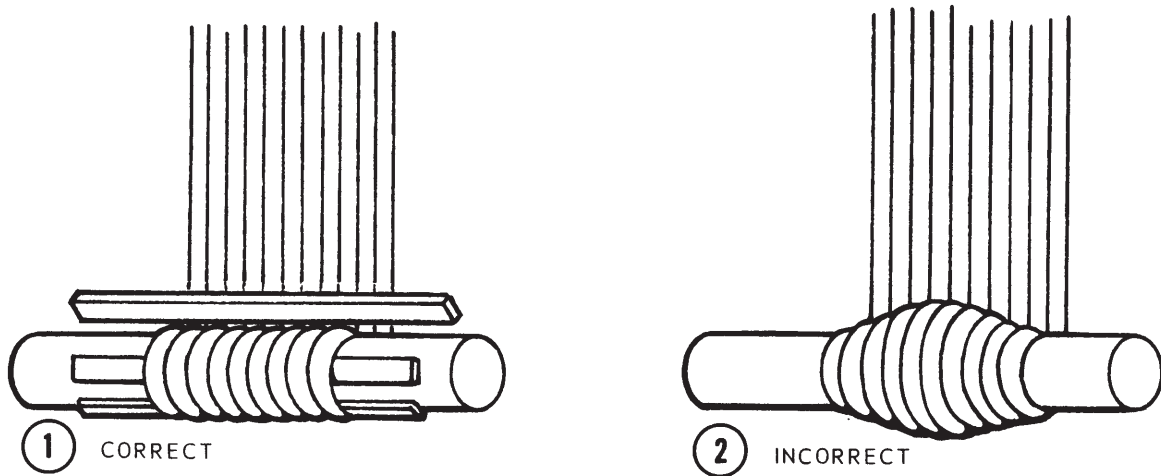
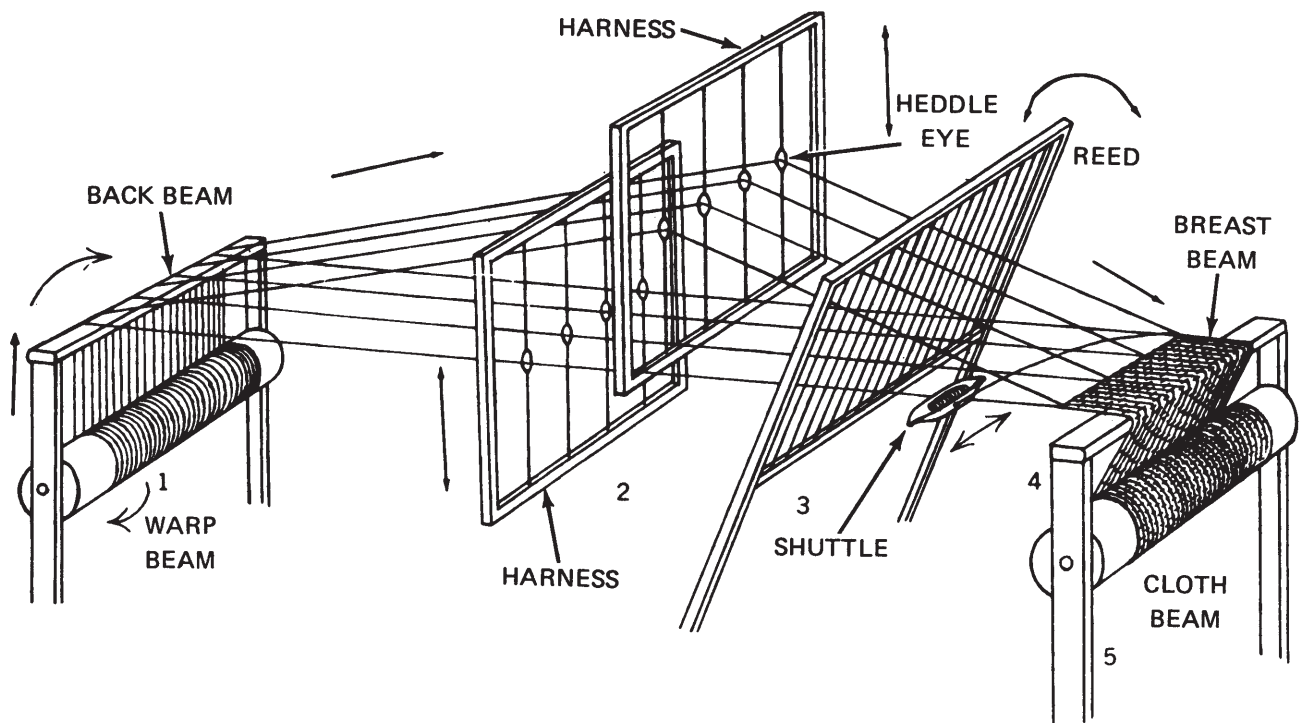

Figure 7-14. Correct and incorrect winding of warp.



(1) Unwoven warp wound on warp beam travels through (2) heddles on harnesses, (3) through the reed in the beater. (4) Shuttle with filling passes through the successive sheds, and weaves cloth. (5) Woven cloth is stored on cloth beam at front of loom. The harnesses move up and down forming the sheds. The beater moves back and forth beating the filling down.

Figure 7-15. Warping the loom.



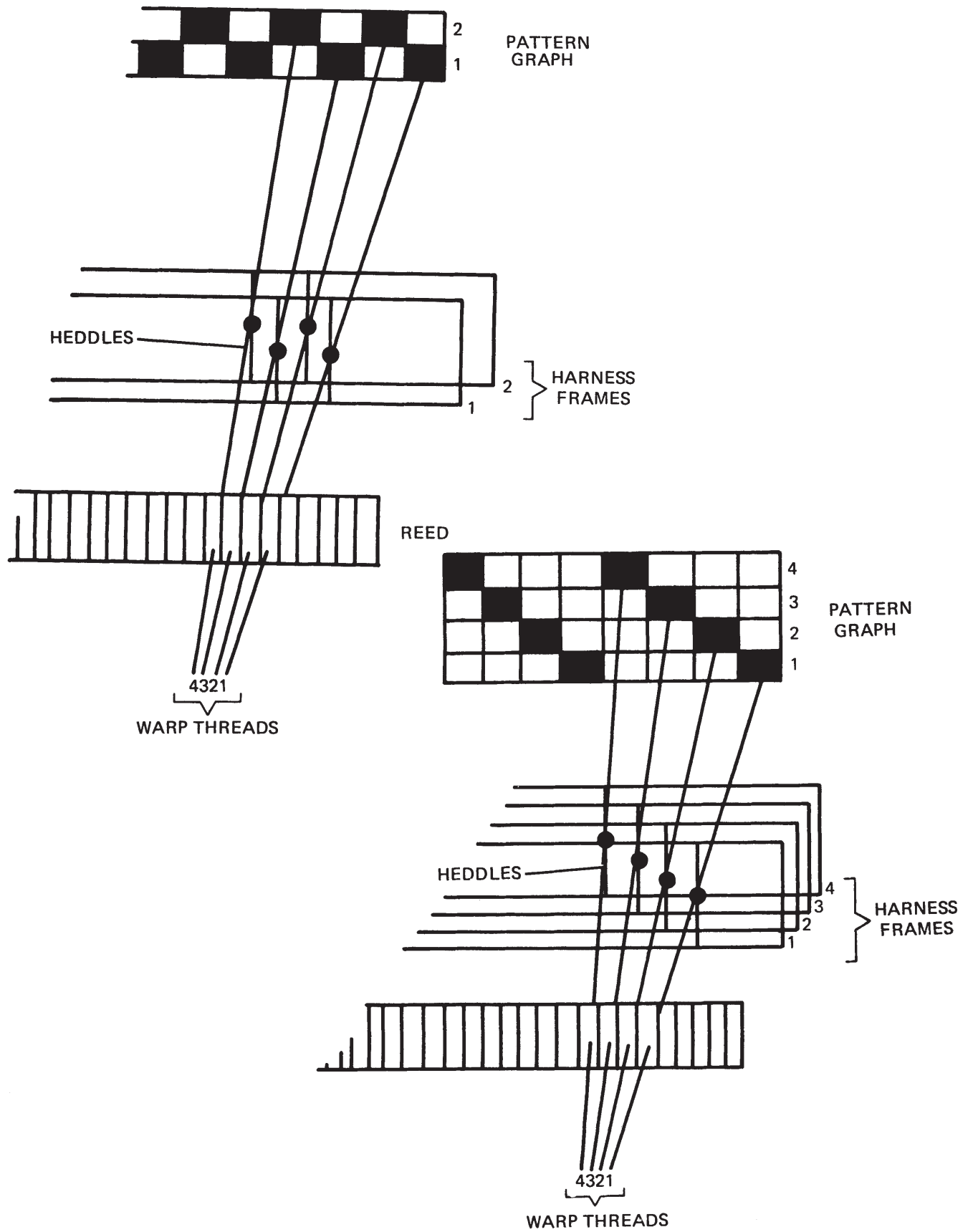

Figure 7-16. Threading heddles of the harness frames in accordance with pattern draft.



Figure 7-17. Sley hook.

(d) To detect early any possible threading mistakes, check the threading completed before repeating the pattern or possibly every 10 or 20 threads. One person should read off the pattern graph while the other checks for accuracy. Make any needed corrections; then catch all the threads and tie them in a loop knot to keep them from falling out of the heddles. Proceed with threading of the next group of threads.

(2) *Sleying the loom.* Sleying is the process of threading the warp through the dents of the reed or sley (P and Q of fig 7-4 and fig 7-15). The beater (O of fig 7-4) should stand in an upright position between the heddle frames and the breast beam. It may be fastened in place with cords. This is a very simple process; however mistakes are easily made and difficult to correct unless they are detected immediately. Too many threads in a dent or a missed dent will make an ugly streak for the full length of the web; therefore it must be corrected. Right-handed persons usually find it easier to sley from the right side to the left. Much time is saved when two persons sley the reed together, one working from the front of the reed and one working from the back of the reed as follows:

(a) The person in front of the reed holds the sleying hook (fig 7-17) with its slotted side down and inserts it through the dent where the web is to begin (a2)(b) above).

(b) The person in back of the reed takes each thread in the order in which it has been threaded through the heddles and places it under the hook.

(c) The person in front draws the hook with the thread attached back through the reed, using a downward cutting motion.

(d) The process is repeated until all threads have been sleyed.

(3) *Tying the warp to the cloth beam.* After the sleying has been completed and any mistakes have been corrected, the apron (material fastened to the cloth beam) is pulled from the cloth beam over the breast beam (fig 7-2) so that the warp can be tied to it as follows:

(a) Separate the threads into ten to twelve groups or into as many groups as there are loops or holes in the apron.

(b) Tie the groups to the apron or rod (fig 7-13), starting at the center. The tension of the threads must be kept uniform within each group and among all of the groups.

(c) Re-check the entire process to insure that any error is identified and corrected before the

rebeaming process is started. Additional methods for identifying and correcting error are provided in paragraph 7-12.

## 7-8. Dressing the Loom With Chained Warp

a. *Making Chained Warp.* The process of making chained warp on either the frame or the reel is the same. The frame (fig 7-18) is used in making warp of 100 threads or less and 10 yards (9 m) or less in length. The reel (fig 7-19) is used to make warp of 100 to 300 threads and 6 to 25 yards (5.4 to 22.5 m) in length. Warps which must be longer than 25 yards (22.5 m) require sectional beaming (para 7-7a). Warp on either the frame or reel is made as follows:

(1) First, make a guide string of a contrasting color or the length that the warp should be. Tie the guide string on peg A (fig 7-18 or 7-19); then go under peg B and over pegs C and D. If using the frame (fig 7-18), continue around enough of the pegs to end at peg E; then tie off the guide string. If using the reel (fig 7-19), make enough revolutions of the reel to end at peg E; then tie off the guide string.

(2) Begin the actual warp by tying to peg A and following the guide string to peg E; then take the warp in reverse to peg D, go over peg D, under C, and over B, thus making a cross between pegs B and C.

(3) Continue this process until the desired number of threads are wound.

(4) Secure the cross of threads between pegs B and C in place by inserting lease sticks (fig 7-20) in the same position as the B and C pegs. This cross makes it easier to tie the warp threads onto the warp beam or to thread them into the loom in the correct sequence. Tie the ends of the lease sticks together (fig 7-20). The cross may be secured with a string (fig 7-20) or with tongue depressors with their ends taped together.

(5) Remove the warp from the frame or reel by chaining it (fig 7-21). First, remove the warp from the bottom peg and loop it over the hand; then pull the section marked "2" in figure 7-21 through the loop, using the hand as one would use a crochet hook. Pull another section of warp through this loop and continue the process of making a chain until all the warp on the frame has been chained to the position of the cross. Tie the last loop to the remaining warp with a contrasting string. Do not pull the remaining warp through the last loop, as this would prevent the release of the chain when the end of the warp is to be pulled for dressing the loom.

b. *Warping the Loom With Chained Warp.* The process for dressing the loom with chained warp is in reverse to that for dressing it with sectional beamed warp (fig 7-15). The loom is warped from the front to the back. The reed is sleyed before the heddles are threaded.

(1) *Centering the warp in the reed.* Based upon the width which the web is to be, find the center area

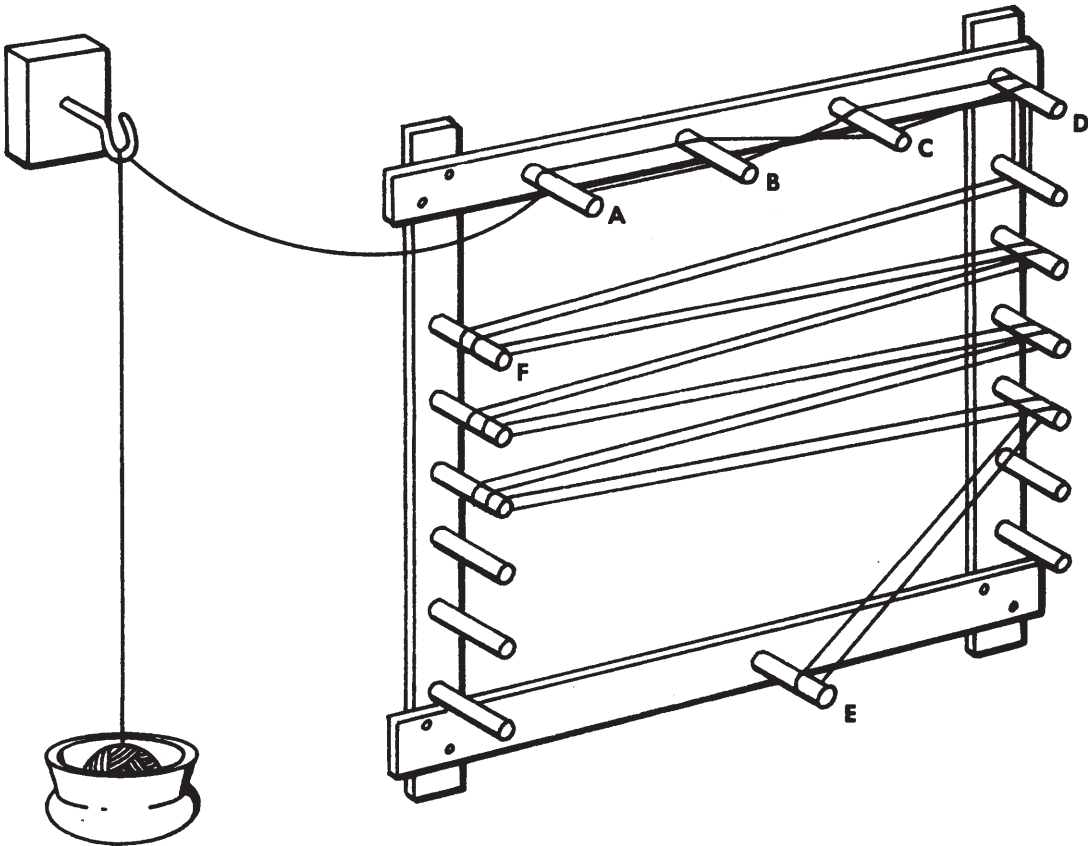

Figure 7-18. Warping frame with warp.



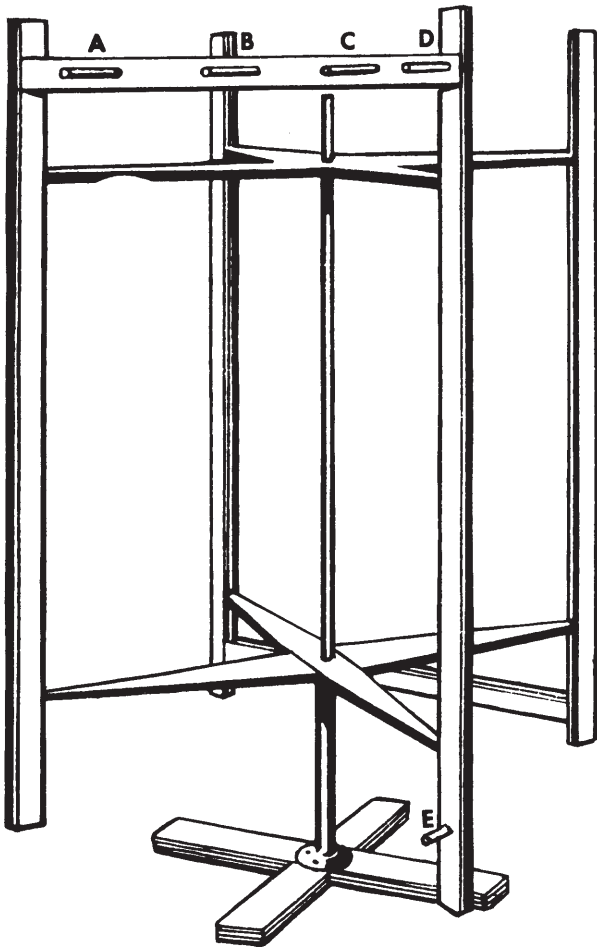

Figure 7-19. Warping reel.

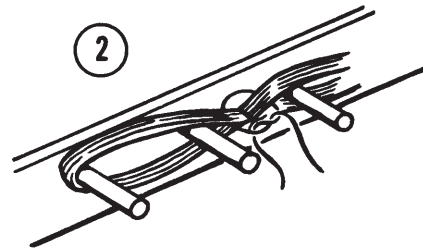
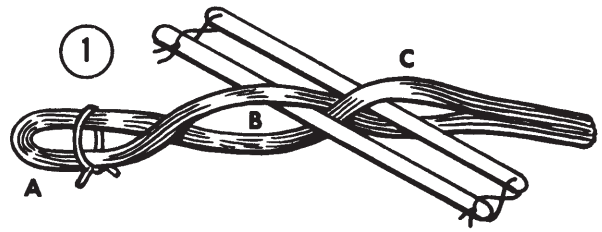

Figure 7-20. Cross of warp secured with lease sticks or tied with a string.

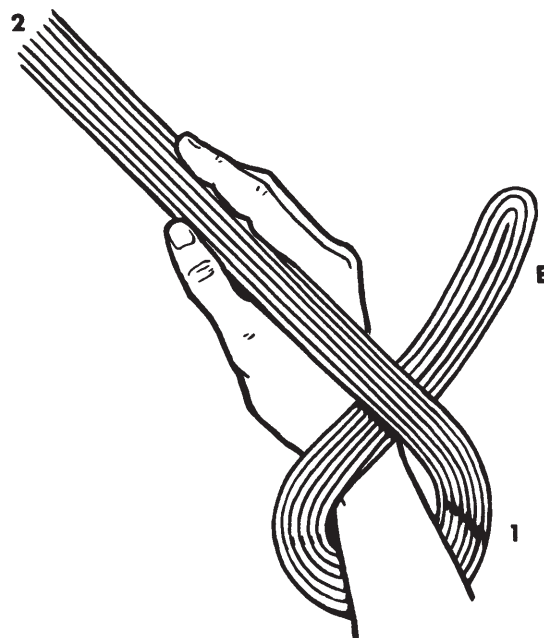

Figure 7-21. Initial step in chaining a warp.

of the reed through which the warp is to be sleyed. The warp should always be as near to the center of the reed as possible. The following method may be used:

(a) Determine the number of dents in the entire reed by multiplying the dents per inch by the length of the reed, excluding the flat pieces at the sides.

(b) Determine the number of dents needed for the number of warp threads and subtract this number from the total number of dents ((a) above).

(c) Divide the dents not needed for the warp threads ((b) above) by two. This gives the number of dents to remain empty on each side of the reed.

*Example:* If the reed has 200 dents and 160 warp threads are to be sleyed with 2 threads to the dent, 80 dents will be needed. Eighty from 200 leave 120 dents which will not be needed; therefore, 60 dents on each side of the reed must be left empty.

### (2) *Sleying the loom.*

(a) Lay the lease sticks and part of the chain on top of the breast beam (Ⓕ of fig 7-4), letting the remaining chain rest in a box on a chair to prevent it from getting dirty and from pulling on the other part of the warp.

(b) Cut through the ends of the loops which were made a peg A of the warping frame or reel (figs 7-18 and 7-19).

(c) With one person positioned to the front of the reed and one to the back of the reed, sley the ends of the chained warp through the reed.

(d) The person in back of the reed holds the sleying hook (fig 7-17) with its slotted side down and inserts it through the dent where the web is to begin at the right.

(e) The person in front of the reed takes the first one or two threads from over one of the lease sticks and places them under the threading hook.

(f) The person in back of the reed draws the hook with the threads attached back through the dent, using a downward cutting motion.

(g) The two persons repeat the process, except that the threads are taken from over the opposite lease stick each time the process is repeated.

(3) *Threading the loom.* The process for threading the heddles with chained warp is the same as that for sectional beamed warp (para 7-7b(1)) except that the warp is threaded through the heddles as it comes from the reed instead of the warp beam.

c. *Beaming Chained Warp.* After the heddles have been threaded with chained warp, the warp is put onto the warp beams (Ⓒ of fig 7-4) as follows:

(1) pull the warp threads through the harnesses until they can easily reach the back beam and adjust them to the same length.

(2) Divide the threads into as many groups as there are loops or slits in the apron of the warp beam and lay them across the back beam (Ⓔ of fig 7-4).

(3) Starting with the groups in the middle, tie

them through the slits in the apron or to the rod attached to the warp beam (fig 7-13); then tie the groups on the sides, alternating from one side to the other to keep the tension even.

(4) At the front of the loom, unchain two or three feet of the warp at a time and comb it with the fingers to remove any tangles before it reaches the reed.

(5) With one person holding the warp at the front of the loom to keep the tension taut, a person at the back of the loom turns the warp beam, rolling the unchained warp onto it.

(a) Before turning the warp beam, check the direction in which it should be turned so that the dog will engage correctly in the ratched wheel to hold tension on the warp.

(b) True the wrap knots on the beam for an even start of all of the warp by laying folded brown paper or a board over the row of knots. The board should be about 1/8 inch (3 mm) thick and not less than 1/2 inch (12 mm) wide. As rounds are continued, use additional boards to prevent a pileup of the warp (fig 7-14). For good warping, the threads must be kept firm, taut, and even.

(6) Continue the process of warping until only 2 feet (60 cm) remain in front of the reed; then remove any tangles from it and trim the ends to an even length.

(7) Separate the warp ends into as many groups as there are loops in the apron on the cloth beam (Ⓐ of fig 7-4); then tie (fig 7-13) the groups to the apron, starting at the center and alternating from one side to the other.

(8) Re-check the entire process for accuracy and correct any errors before the weaving process is started (para 7-12).

## 7-9. Winding Shuttles of Weft and Tabby Thread

The weft (woof) in each color to be used in the web and the tabby thread are wound onto shuttles of the appropriate type.

a. *Flat Shuttle.* This flat shuttle (fig 7-5) has grooves on each end. It is designed for light weft threads and is used mainly with table looms. The weft is wound onto the shuttle from a spool.

b. *Boat Shuttle.* This boat-shaped shuttle (fig 7-15) contains a bobbin for thread. It is used for very fine thread.

c. *Rug Shuttle.* This is a large shuttle (fig 7-5) used to hold heavy or large weft and tabby thread. The skein winder (fig 7-22), also called a swift, is used to hold skeins of yarn for winding onto the rug shuttle. When wool yarn is being wound, a little slack should be allowed to prevent the yarn from being stretched.

## 7-10. Gaiting the Loom

After the loom is warped, it usually needs gaiting or adjusting. Adjustments should be made with cord

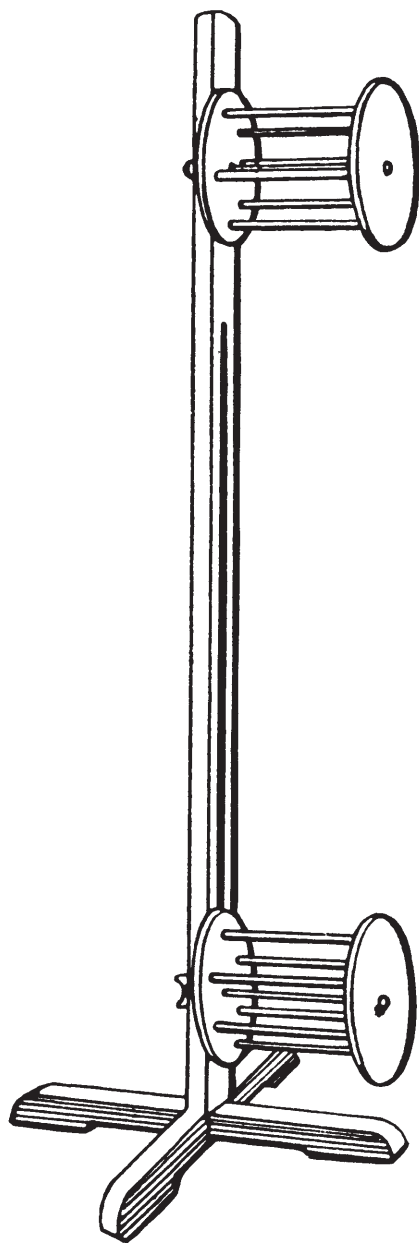

Figure 7-22. Skein winder.

which as been woven of linen, if possible, and which is not too heavy. Suitable cord is the type used in upholstery or the heavy varnished cord used in deepsea fishing, as well as the more expensive heavy grades of Jacquard cord.

*a. Adjustment of the Harnesses.* The counter-balanced four-harness loom has a castle top (large roller) from which tow heddle horses (small rollers) (Ⓐ and Ⓚ of fig 7-4) are suspended. The four harness frames (Ⓒ of fig 7-4) are suspended from the two heddle horses.

(1) The ends of the heddle horses on each side are attached to the castle top with a cord doubled in half:

(a) Tie the loose ends of the doubled cord to one end of the back heddle horse.

(b) Extend the cord over the castle top then under and over it again. Do not nail the cord to the castle top.

(c) Form a snitch knot (fig 7-23) in the doubled end of the cord and secure the cord to the front heddle horse.

(d) With another doubled cord of the same length, repeat the steps described above, thus securing the other ends of the heddle horses.

(e) Re-adjust the cords as necessary to make the heddle horses hang level about halfway between the castle top and the harness frames ((2) below); then tie them together temporarily to keep them in place while gaiting the other parts of the loom.

(2) The four harness frames are hung in pairs from each of the two heddle horse, using the same procedure described in (1) above. The harness frames should hang at the level which permits the warp to pass from the back beam to the breast beam (Ⓔ and Ⓕ of fig 7-4) in a straight line. If the warp deflects upward, the harness frames have been hung too high. After proper adjustments of the harness frames, they should be temporarily tied in place while gaiting the lams and treadles.

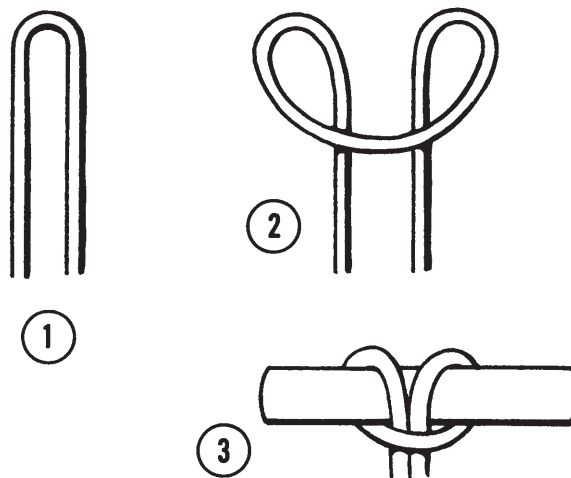

Figure 7-23. Tying a snitch knot.

*b. Tieup of the Lams and Treadles.*

(1) The lams (Ⓜ of fig 7-4) serve the purpose of bringing down the harnesses evenly. Each lam is connected to the center of the corresponding harness frame with a cord by means of a snitch knot. A chain may be used instead of a cord. The lams must be tied so that their unattached ends slant slightly upward to prevent them from coming in contact with the treadles during operation. Once the tieup has been completed, the lams are temporarily tied together to keep them in position while they are being tied to the treadles.

(2) The treadles (Ⓛ of fig 7-4), which are pressed to raise and lower specific harnesses, are connected to



the lams which have been connected to the harnesses. Which treadle should be connected to raise and lower each harness is left to the discretion of the weaver. For some weaves, the pattern may require that one lam be tied to several treadles. The exact height at which the treadles should be tied is also left to the discretion of the weaver, as they must not be so high that the weaver hits his knee on the cloth beam as he reaches for the treadles. However, the space left between the treadles and the floor must be adequate to allow the treadles to be pressed down enough to open the shed sufficiently for easy passage of the shuttle. Pieces of wood or books should be placed under the treadles to hold them at the desired height until they can be tied with snitch knots to the lams.

### 7-11. Weaving Process and Techniques

After all preparations have been made for weaving, the actual weaving process can be started. Although this process is not complex, it requires knowledge and skill which can be acquired only by practice and attention to details.

#### a. Primary Steps in the Weaving Process.

##### (1) Depress the treadles and pass the shuttles.

The treadles are depressed in accordance with instructions provided with the selected pattern or weave (table 7-2), thus separating the warp threads into a shed. The shuttle is passed through the shed, (figs 7-6 and 7-15), depositing a weft or tabby thread, as appropriate, between the two layers of warp threads. The weft or tabby thread should be pulled with only enough tension to have it lie against the warp and not to force the weft and warp together, as this would cause the web to become narrow. Furthermore, leaving the weft thread at a slant until the beater is pulled will produce a more even selvage on the web.

(a) An example of treadling instructions is "4-3-1x then 1-2-6x." This means to depress treadles Nos. 4 and 3 one time and treadles Nos. 1 and 2 six times. When a pattern indicates that a tabby thread is to be used it is understood that the standard treadling for the tabby thread (table 7-2) is to be accomplished alternately with the pattern treadling. For example, the

weaver would accomplish instruction "4-3-1x then 1-2-6x" as follows:

1. Depress shuttles 4 and 3 (one time) and pass pattern shuttle through shed.
2. Depress shuttles for tabby thread (table 7-2) and pass tabby shuttle through shed.
3. Depress shuttles 1 and 2 (first time) and pass pattern shuttle through shed.
4. Depress shuttles for tabby thread and pass tabby shuttle through shed.
5. Depress shuttles 1 and 2 (second time) and pass pattern shuttle through shed.
6. Depress shuttles for tabby thread and pass tabby shuttle through shed.
7. Depress shuttles 1 and 2 (third time) and pass pattern shuttle through shed, et cetera.
8. After the sixth time followed by the tabby treadling, the weaver starts with "4-3-1x" again.

(b) If treadling instructions are not available, they can be determined on the draft pattern used in threading the harnesses (para 7-5c(3)). With the honeysuckle graph pattern used as an example (fig 7-24), the pattern threads represented by the dark blocks are circled by two's, overlapping the second dark block in the previous circle each time:

1. Beginning on the right side of the draft, circle the first two pattern threads which are in harnesses 4 and 3.
2. Circle the second and third threads which are in harnesses 3 and 2.
3. Circle the third and fourth threads which are in harnesses 2 and 1.
4. Circle the fourth and fifth threads which are in harnesses 1 and 4.
5. Circle the fifth and sixth threads which are in harnesses 4 and 3.
6. Circle the sixth and seventh threads which are in harnesses 3 and 4.
7. Circle the seventh and eighth threads which are in harnesses 4 and 3.
8. Continue this circling process to completion. With this information, the treadling instructions can be easily written as follows: 4-3-1x, 3-2-1x, 2-1-1x, 1-4-1x, 4-3-3x, et cetera.

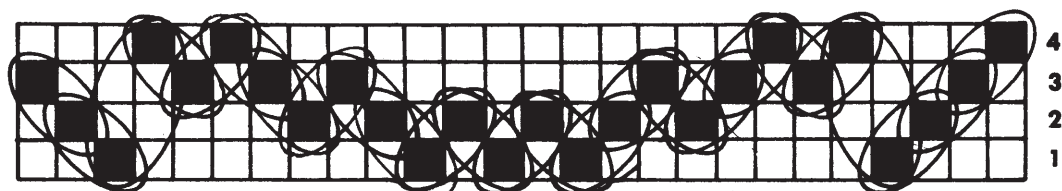

Figure 7-24. Graph of the honeysuckle pattern used to determine treadling.

(c) The shuttles of weft colors are used in the same succession as used in the warp. For instance, to weave the MacLeod plaid (table 7-1), 8 yellow weft threads are deposited to form a square of yellow in the areas where 8 yellow threads are found in the warp. Six black threads are deposited in the same manner. The weft thread is started and ended each time it is used.

Table 7-2. Treading Instructions for Weaves and Tabby Threads.

WEAVE	TREADING INSTRUCTIONS
1. Plain or tabby weave*	1-3 and 2-4 alternately.
<hr/>	
2. Twill weaves (woven with or without tabby thread)	
a. Plain twill	1-2, 2-3, 3-4, 4-1; repeat starting at 1-2.
b. Herringbone or zigzag	1-2, 2-3, 3-4, 4-1, 3-4, 2-3; repeat, starting at 1-2.
c. Goose eye	4-1, 3-4, 2-3, 1-2 repeated the desired number of times, 2-3, 3-4; repeated starting at 4-1.
<hr/>	
3. Honeysuckle	4-3-1x, 3-2-1x, 2-1-1x, 1-4-1x, 4-3-3z, 2-3-3x, 1-2-6x, 2-3-3x, 4-3-3x, 1-4-1x, 1-2-1x, 2-3-1x; repeat starting with 4-3-1x.
<hr/>	
*NOTE: Tabby thread between pattern weft	Usual treading: 1-3 before shuttle is put through shed from left to right; 2-4 before shuttle is put through shed from right to left.

(2) *Pull the beater.* Each time the weft or tabby thread shuttle is passed through the shed, the beater must be pulled forward to beat the thread into place. Different types of thread require different techniques in beating; but regardless of the technique used, the beating must be consistent and even. Fine cloth will not be produced unless the beater is pulled with the same amount of strength each time and is grasped so as to insure equal pressure on all areas. It may be grasped with both hands equal distances from the edges or with one hand in the center.

(a) Cotton weft often beats better with a gentle snap of the beater.

(b) When heavy web such as a rug is made, the beater can be pulled rather hard. For an extra firm beat, the web can be beaten before and after the shuttle is passed through each shed.

(c) For wool, the beating must be very gentle. Just the weight of the beater is often enough. Pulling the beater with too much force packs wool weft too tightly, making the web hard instead of soft.

(3) Periodically wind the web onto the cloth beam and release the warp. As the web is woven, the ratchet wheels on the cloth and warp beams are used to wind the web onto the cloth beam and to release warp from the warp beam, respectively.

*b. Special Techniques Required in the Weaving Process.*

(1) *Filling the spaces left between the groups of threads tied to the apron.* Spaces left between the groups of threads when they were tied to the apron are eliminated by weaving in the tabby pattern, using heavy scrap material such as rags or ends of roving instead of weft. This filler should be left in loops at the selvage edge to allow the groups of threads at each edge to spread in both directions. The gaps between the groups of warp threads decrease in width as more and more of the filler is used. When the warp threads become evenly spaced across the loom and the edges spread out to the width planned for the web, the filler is discontinued. After the web is completely woven, this filler is removed.

(2) *Weaving the heading for the web.* The heading is woven in plain weave, using tabby thread instead of weft. The heading provides a firm base for the fringe at the end of the web. If the heading is to be used as a hem on the article, it should be made somewhat deeper. If the tabby thread has much thickness, the end of the thread should be split and started as described in (3) below.

(3) *Starting and ending the weft in the body of the web.*

(a) The loose end of the weft on the shuttle is untwisted to show the strands; then the strands are divided into two halves for about 2 inches (50mm). The shuttle is passed through the shed, leaving the two halves on the edge of the warp. One of the two halves is pulled through the warp threads at the top of the shed, and the other half is taken around the front warp thread and back into the shed (fig 7-25). The shed is closed, and the half extending upward is cut off at the point where it meets the other half, leaving the weft secured without extra thickness at any point. The same technique is used to end the weft as to start it.

(b) For a pattern weave which requires the use of a tabby thread after each weft thread, the tabby thread is left secured in the heading ((2) above) to be continued in the body. For the plain weave, which does not require the use of a tabby thread after each weft thread, the tabby thread used in the heading is ended, using technique described in (a) above.

(4) *Splicing the weft.* The web to be woven most likely requires more than one shuttle of weft. Since knots show when woven into web, the two lengths of

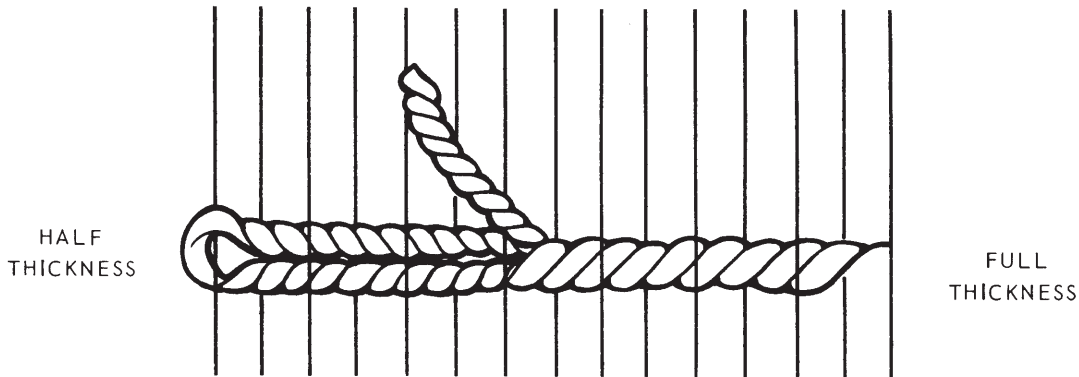

Figure 7-25. Starting the weft.

weft are spliced together. Although splicing may be accomplished in several ways, the following technique is recommended: The end of weft in the shed and the end of the weft to be added are separated into strands, then half of the strands on each end are cut off at different lengths. These tapered ends are overlapped and the beater is pulled thus forming a uniform thickness of weft. If strips of different colors are being used, the weft of one color should be ended in the last row of that color; then the new color should be started in the next row ((3) above).

(5) *Ending the web.*

(a) After the web has been woven to the desired length and ended with a complete design of the pattern, the pattern weft is secured ((3) above). The web is ended in reverse of the way it was started: The

weaving as in the heading is accomplished ((2) above); then the spaces between the groups of threads tied to the warp beam are filled ((1) above) to prevent raveling.

(b) When all weaving is completed, the tension on the back ratchet wheel is removed; and the web is pulled forward until the end of the weaving reaches the breast beam. All tension on the warp threads must be loosened, including the weight of the web. If fringe is part of the plan, the warp threads must be left long enough to tie into fringe. Groups of warp coming through the dents of the beater are cut and immediately tied together into four or five loose knots against the beater so that they will not be pulled from the beater (fig 7-26). The web is then untied from the apron of the cloth beam.

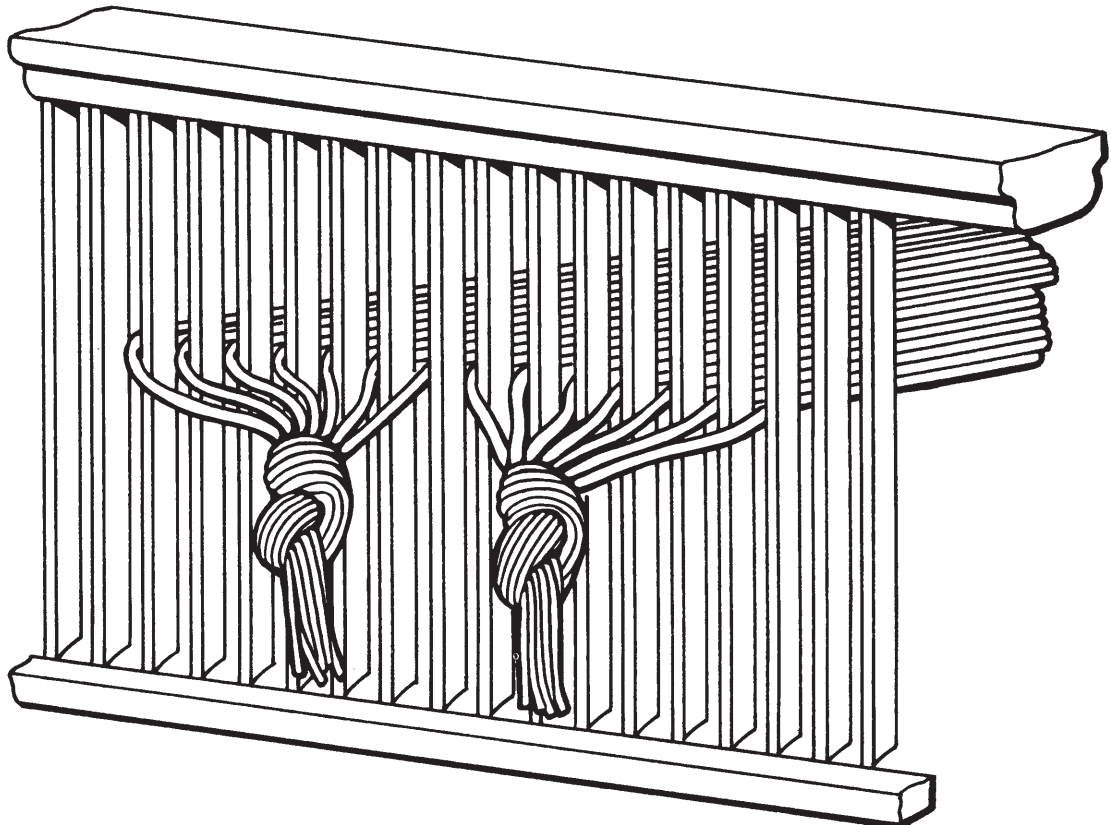
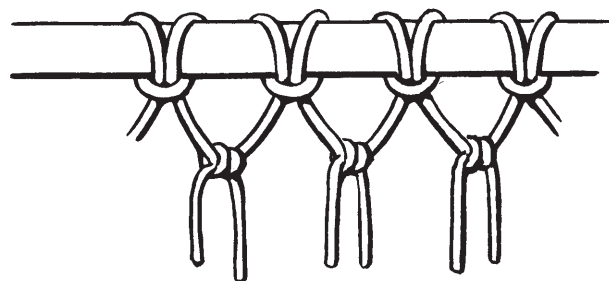

Figure 7-26. Tying the warp cut from the web.

(6) *Finishing the web.* The proper finishing of the web is an important part of the article. In making fringe, the filler is removed from only one end at a time.

All the filler can be removed from each end at one time, or it can be removed as the fringe is tied (fig 7-27).



① SQUARE

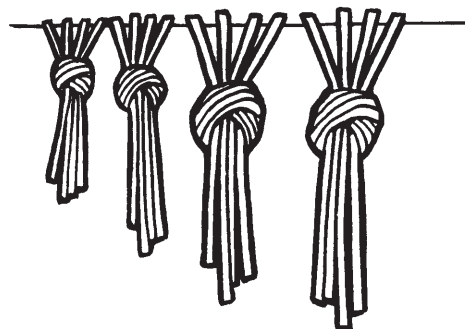

② OVERHAND

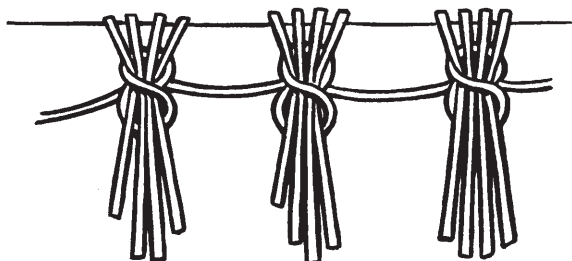

③ NEOLITHIC

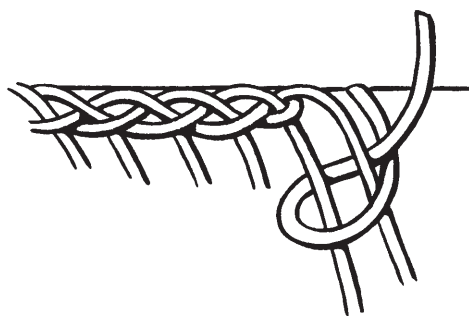

④ PHILIPPINE

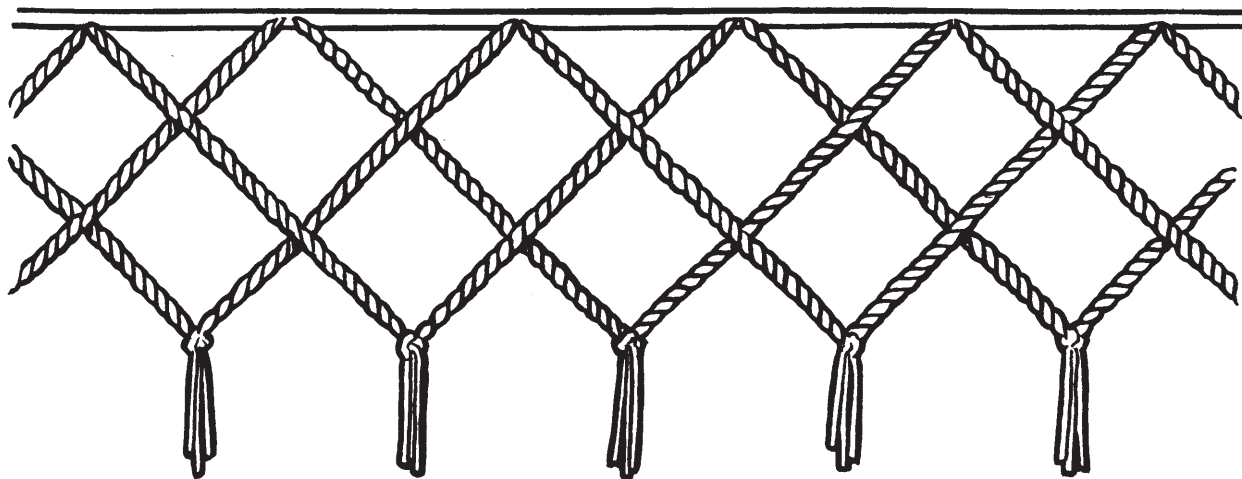

⑤ MEXICAN BRAIDED FRINGE

Figure 7-27. Fringe and knots used in fringes.



## 7-12. Methods of Identifying and Correcting Errors

A loom should be completely checked after each aspect of the preparation process (para 7-6) to prevent errors which are difficult to correct after the weaving process is started. After the loom is warped and the warp is tied down, it can be further checked by weaving with tabby treadling and a shuttle of filler. In most patterns, the tabby treadling will produce an over-and-under simple weave. Any inconsistencies which appear in this simple weave at regular intervals are likely to be a part of the pattern; otherwise, they indicate errors in threading. Some of the more common mistakes can be corrected as follows:

a. If a group of warp threads is found to be twisted between the back beam and the heddles, it is usually worthwhile to remove the twisted ones from the dents and heddles, straighten them out, and re-thread them according to the pattern.

b. Heddles may become crossed because they were not put on the frame carefully. They should be slipped off the frame and uncrossed. If this process would involve too much time, one of the crossed heddles may be cut and removed from the frame.

c. Threads found to be crossed between the heddles and the shed must be pulled from the dents and re-threaded correctly. Sometimes, several of the warp threads must be re-sleyed to correct the error.

d. If errors have occurred in threading the heddles, it is usually expedient to remove all threads from the beginning of the error and re-thread them correctly. Sometimes, a great deal of re-threading can be avoided by adding string heddle (fig 7-28) in a certain place on the harness. A string heddle is made from a piece of regular cotton warp string which is twice the length of a regular heddle, plus about 4 inches (10 cm). This string is hung evenly over the top heddle rod. Two knots are tied in the double string, one exactly level with the top part of the eye of the regular heddle and one exactly level with the lower part of the eye. The loose ends of this string heddle are then tied together under the bottom heddle rod.

e. If a dent in the reed is found to be empty or if two threads instead of one as planned are put through a single dent, the threads must be re-sleyed, beginning with the error and working to the nearer edge. Otherwise, the mistake will be noticeable in the web.

f. Broken warp threads are fixed with replacement threads rather than with knots. When a broken warp thread occurs, a matching thread long enough to complete the length of the woven piece is cut. It is threaded through the heddle and reed and pinned down in position on the web. The other end is tied with a weaver's knot (fig 7-29) to the end of the broken thread at the back beam. When the weaver's knot reaches the heddles, the matching thread is extended to the back

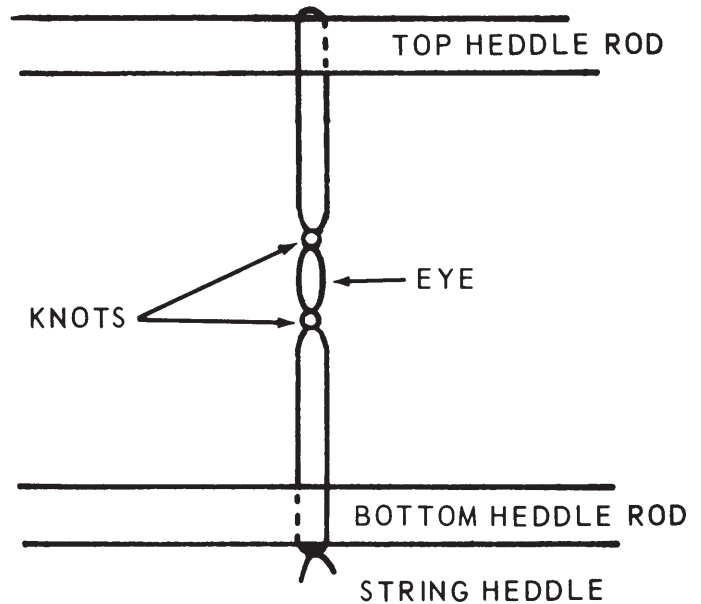

Figure 7-28. String heddle.

beam and tied in a weaver's knot again. This procedure is continued until the web is complete.

**CAUTION:** Do not break off the broken warp thread. After the web is removed from the loom, the end of the broken warp thread is re-threaded and included in the warp as it is tied to the apron.

g. Faulty tension of the warp threads can cause a poor shed and/or uneven weaving. This is caused from careless warping of the beam, tying the warp to the apron with uneven tension, and beating the weft with unequal force on all parts of the beater. If faulty tension occurs, specific threads can be tightened by putting a folded piece of paper between the loose threads and the back beam. If the tension is especially uneven, the warp will have to be removed from the beam and rewound with more care.

## 7-13. Tying-on Method to Avoid Re-threading the Loom

Tying-on is a short cut which may be employed when re-warping the loom for the same pattern. It should be used only when the old warp was free of errors. Tying-on is accomplished as follows:

a. Tie the old remaining warp in groups to prevent it from being pulled out of the dents and heddles.

b. If the new warp has been chained, place the lease sticks with the cross on the breast beam as for sleying. Instead of sleying, tie each thread in sequence to each end of the old warp.

c. If the new warp has been beamed, tie each thread in sequence to each end of the old warp.

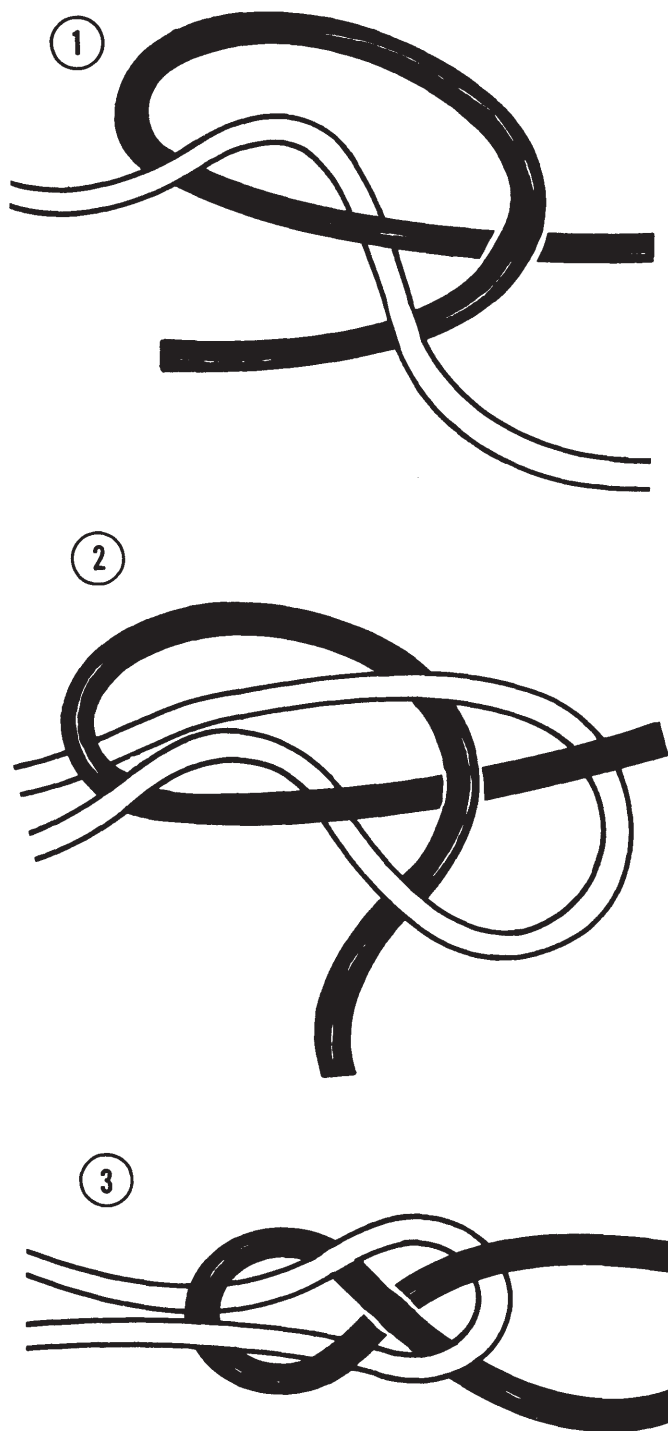

Figure 7-29. Weaver's knot.

d. After all threads are tied and the knots are carefully and gently pulled through the heddles and dents, tie the ends of the old warp to the cloth beam or to the warp beam, depending upon the type of warp being used. Using the old warp as "dummy warp" decreases the amount of new warp required.

#### 7-14. Care and Storage of Equipment and Materials

a. Looms which have been prepared for weaving must be covered when not in use to protect the warp, weft, and web from dust.

b. All materials must be stored in a dry, clean area. The loom bench (fig 7-30), on which the weaver sits, has a shallow box under the hinged seat for storing materials.

c. Woolen materials must be protected from moths. Furthermore, they must not be packed too tightly. If a loom has been threaded with wool warp, the tension must be released when the loom is not in use to keep the warp from stretching.

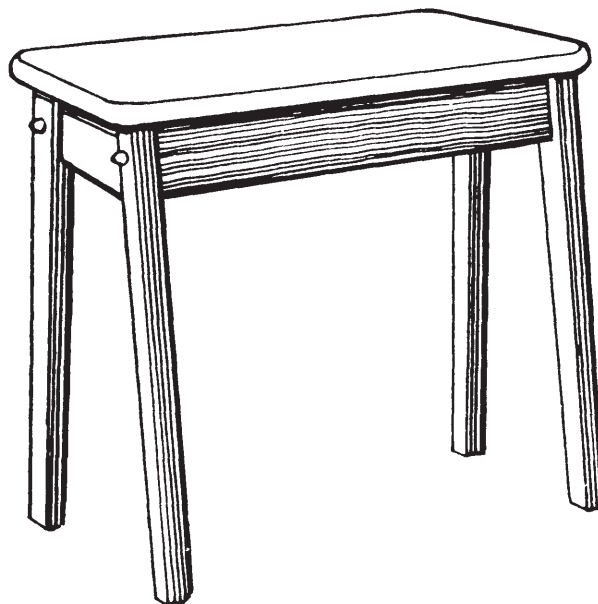

Figure 7-30. Loom bench.

#### 7-15. General Weaving Terms

a. *Apron*—Material, usually canvas, fastened to the cloth beam for use in tying the warp ends to the cloth beam.

b. *Beaming the Warp*—Rolling the warp onto the warp beam.

c. *Beams:*

(1) *Back beam*—Top crosspiece at the back of the loom over which the warp passes before it enters the heddles.

(2) *Breast beam*—Top crosspiece at the front of the loom over which the finished cloth passes to the cloth beam.

(3) *Cloth beam*—The roller at the front of the loom on which the cloth is wound as it is woven.

(4) *Warp beam*—The beam around which the warp is wound at the back of the loom

*d. Beater*—The frame which holds the reed and is used to beat the weft into place as cloth is being woven.

*e. Beating*—Pulling the beater to push each weft thread into place as cloth is being woven.

*f. Castle top*—Large roller or bar which extends across the side posts and from which the heddle horses are hung.

*g. Chaining*—A method of looping the warp as it is removed from the warping frame or reel.

*h. Cone*—A shaped core around which threads and light yarns are sometimes wound.

*i. Cross or lease*—The place where the threads cross at the start of a warp to keep the threads in sequence during threading.

*j. Dent*—A single space in the reed through which the warp is threaded.

*k. Draft*—A drawing, usually on graph paper, which indicates the replacement of the threads in the harnesses to form a certain pattern.

*l. Dressing the loom*—The process of preparing and threading the warp for weaving. Also referred to as warping.

*m. Filler*—Weft thread used for weaving until the gaps between the warp threads are eliminated.

*n. Gaiting the loom*—The process of adjusting and aligning the parts of the loom

*o. Guide plate*—A metal plate with holes. It fits on the back beam the same way as a tension box and guides the warp threads as they are pulled toward a section in sectional beaming.

*p. Guide string*—The first string to be put on a warping frame or beam. It serves as a guide in making the warp.

*g. Graph pattern*—Weaving pattern set up on graph paper with each row representing a harness frame and each block representing a heddle.

*r. Harness*—The heddles, heddle rods, and harness frame.

*s. Heading*—A band or edging which may be woven, usually in tabby, at the beginning and end of the body.

*t. Heddle*—A wire, string, or flat piece of thin metal with an eye or slot through which the warp ends are threaded.

*u. Lams*—Horizontal levers attached to a side post of the loom between the harness and treadles. They aid in bringing the harnesses down evenly.

*v. Lease or cross*—The place where the threads cross at the start of a warp to keep the threads in sequence during threading.

*w. Lease sticks*—Two thin sticks used to hold the threads in order at the cross or lease.

*x. Ply*—The number of single strands which are twisted together to form a thread or cord.

*y. Reed or sley*—The comblike device in the beater which evenly spaces the warp threads and beats the weft into place.

*z. Reed hook*—The hook used to facilitate threading the warp through the dents of the reed and the eye of the heddle.

*aa. Roller*—Another name for the cloth beam, for the warp beam, and for the castle top on which the harnesses are supported.

*ab. Selvage*—The edge of the cloth.

*ac. Shed*—The horizontal opening, made by the separation of the warp thread, through which the shuttle passes.

*ad. Slot*—Passage of the shuttle through the shed, depositing one weft thread.

*ae. Shuttle*—The stick or boatlike container which holds the weft.

*af. Skein winder or swift*—An adjustable revolving holder used to facilitate the winding or unwinding of skeins or yarn.

*ag. Sley or reed*—The comblike device in the beater which evenly spaces the warp threads and beats the weft into place.

*ah. Sleying*—The threading of the warp through the dents of the reed.

*ai. Snitch knot*—A knot frequently used in gaiting the loom.

*aj. Spool rack*—A rack designed to hold a number of tubes of warp while beaming.

*ak. Tabby thread*—The thread inserted between pattern threads.

*al. Tabby weave*—The plain weave formed by interlacing of single warp and weft threads.

*am. Tension box*—A device designed to maintain even tension on the warp threads and to guide them onto the warp beam.

*an. Treadles*—Levers used to raise and lower the harnesses. They are often referred to as levers on a table loom and pedals on a floor loom.

*ao. Treading*—Pressing down certain treadles of the loom to raise or lower the attached harness. When this is done in a prescribed sequence, it makes the pattern in weaving.

*ap. Tying down*—The tying of the warp threads to the apron.

*aq. Warp*—Threads running lengthwise of the loom across which the weft threads are passed to form cloth.

*ar. Warping*—The process of preparing and threading the warp for weaving. Also referred to as dressing.

*as. Warping board*—A wooden frame with pegs spaced so that small warps can be wound or made.

*at. Warping reel*—A revolving open barrellike

frame around which a fairly long warp can be wound or made.

*au. Weft or woof*—Threads woven horizontally across the warp to form cloth.

*av. Web*—A piece of woven cloth.

*aw. Woof or weft*—Threads woven horizontally across the warp to form cloth.