

# WOOLEN AND WORSTED FANCY LOOMS

(PART 1)

Serial 487A

Edition 1

## INTRODUCTION

**1.** Cam-looms, although a very desirable type for weaving fabrics of simple construction, are not adapted to those of a more complicated nature. The cams occupy considerable space, so that the number that can be economically used is somewhat limited, eight being the largest number that it is customary to use. Since the number of cams is limited, it follows that only comparatively few harnesses can be employed, and consequently only weaves complete on a few ends can be woven. The construction of a cam-shedding motion also is such that there can only be comparatively few picks in one repeat of the weave. It will likewise be seen that in a mill where a large number of weaves are used and the looms must constantly be changed from one weave to another, cam-shedding motions are totally unsuitable, on account of the large variety of cams that it would be necessary to carry in stock. The changing of a cam-loom from one weave to another, moreover, causes considerable trouble and expense. Because of these difficulties fancy looms having a special shedding mechanism, generally called a *head-motion*, are used for weaving all woollen and worsted fabrics requiring from 8 to 36 harnesses. They are also generally equipped

COPYRIGHTED BY INTERNATIONAL TEXTBOOK COMPANY. ALL RIGHTS RESERVED

with box motions, whereby more than one shuttle may be used and, consequently, more than one kind or color of filling inserted in a fabric.

**2. Types of Sheds.**—There are three different types of sheds formed on power looms that control the warp threads by means of harnesses: (1) the *close shed*, (2) the *split shed*, (3) the *open shed*.

In the **close shed**, all the harnesses are lowered after the insertion of each pick so that all the yarn is brought in line with the bottom shed, or rather with the bottom line of the shed. Although inaccurate, the phrases *top shed* and *bottom shed* are frequently used in a mill. The word shed really indicates the entire space enclosed by the upper and lower lines of warp. The expressions top shed and bottom shed, as commonly used, are abbreviations for the expressions *top line of the shed* and *bottom line of the shed*, and as they have become popular, they will be used in this connection. In the case of a close shed each harness that is to be raised is lifted from the bottom to the top shed and after the insertion of a single pick is again lowered to the bottom shed. With this method of shedding the harnesses must make many unnecessary movements, for if a harness is to be raised for 2 or more picks in succession, it will have to be lowered and raised again between each pick.

In the **split shed**, after the insertion of each pick, the warp is brought level at a point equally distant from the top and bottom sheds; that is, in the center of the shed. In this motion also the harness makes many unnecessary movements, for all the harnesses must move from the center either to the top or bottom shed at every pick; a harness that is to be raised for 2 or more picks must be lowered to the center of the shed and raised again and a harness that is to be lowered for two or more successive picks must be raised and lowered between the insertion of each pick.

In the **open shed**, the bulk of the warp yarn forms two stationary sheets at the top and bottom lines of the shed. There are no unnecessary movements in this method of

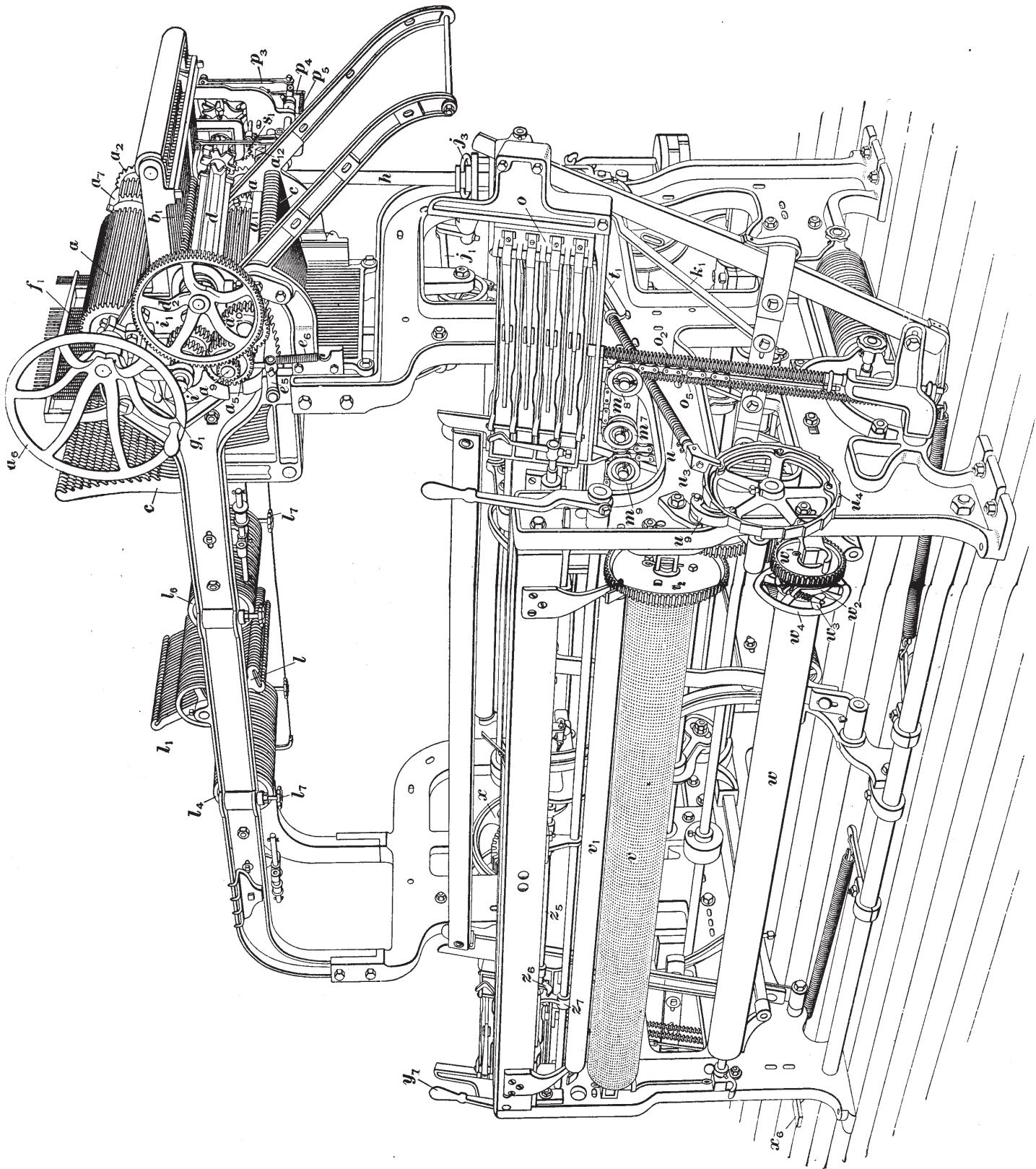
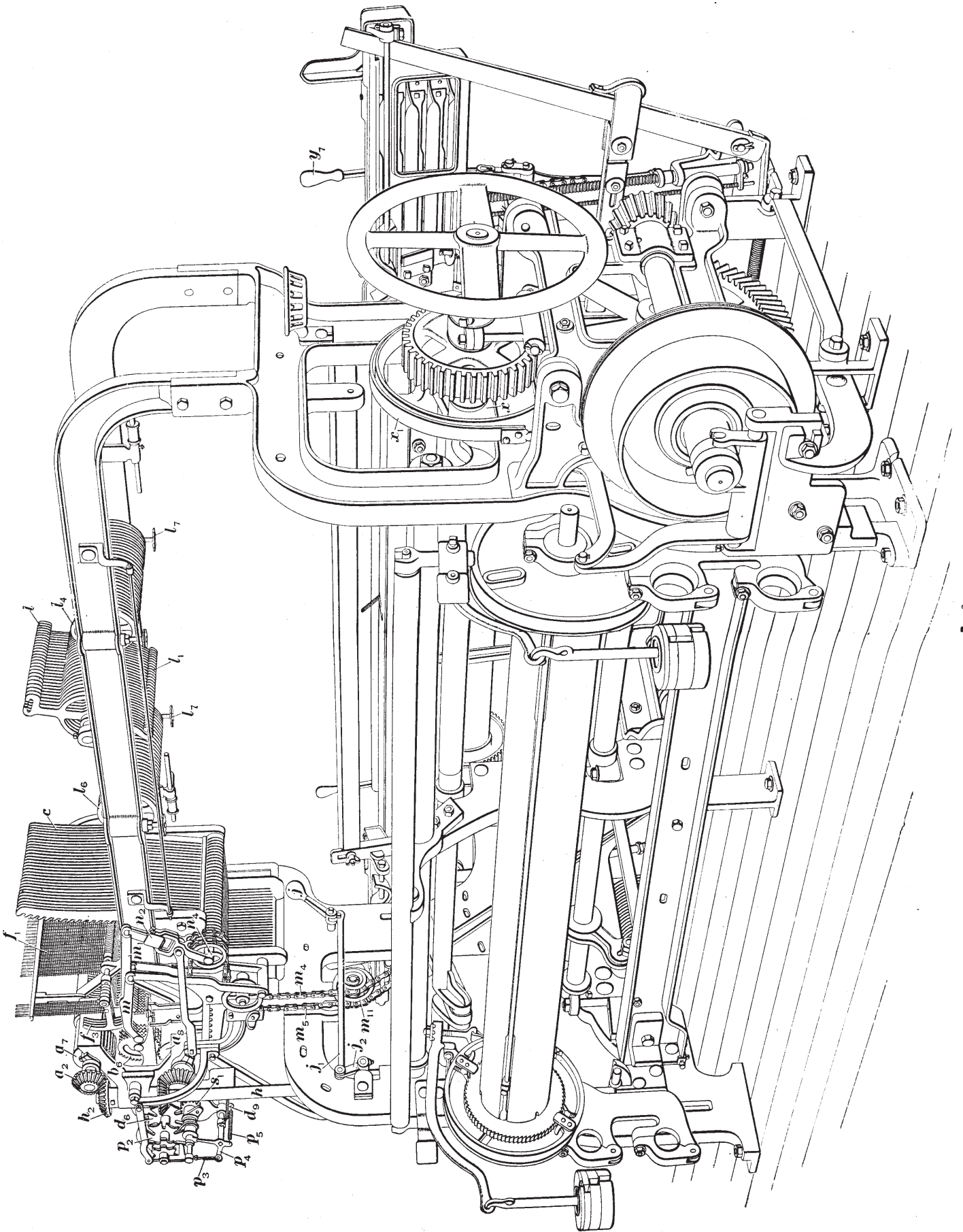

FIG. 1

Double-page spread rotated 90° to fit on page.



Double-page spread rotated 90° to fit on page.

shedding; a harness that is to be raised passes from the bottom to the top shed, while one that is to be lowered passes from the top to the bottom shed. Each harness remains stationary at either the top or bottom shed until its position is required to be changed. All cam-looms form an open shed, as does also the Knowles fancy loom because of the peculiar construction of its shedding mechanism.

---

### THE KNOWLES FANCY LOOM

**3.** The **Knowles fancy loom**, shown in Figs. 1 and 2, the former being a front and the latter a back view, is quite similar in general construction to a cam-loom. It is, however, by virtue of the shedding, or head, motion, adapted for weaving more complicated fabrics, and in fact will weave any woolen or worsted fabric that can be woven with harnesses, from the simplest to the most intricate. It is provided with a box motion, so that any filling pattern may be woven, and generally with a brake motion, whereby the loom may be almost instantly brought to rest. The picking motion, although of similar construction to that of the cam-loom, is arranged to operate both picker sticks at each pick, so that the shuttle may be thrown from either side of the loom, as occasion demands. When both picker sticks are thrown in at each pick, the loom is said to be a **pick-and-pick loom**. Other points of difference between the fancy loom and the cam-loom are in the take-up motion and in various minor details.

---

### KNOWLES HEAD-MOTION

---

#### SHEDDING MECHANISM

**4.** A perspective view of the **Knowles fancy head-motion** is shown in Fig. 3, while Fig. 4 is a sectional view showing the essential parts only. The principle on which this shedding motion operates is as follows: Placed directly above and below a number of vibrator gears  $b$  are two cylinder gears  $a, a_1$  that extend entirely across the head-motion





and have teeth cut on half of their circumferences, the other half being blank; a rotary motion is imparted to them in the direction indicated by the arrows. The vibrator gears  $b$ , of which there are as many as there are harnesses to be operated, are constructed of steel disks about  $\frac{3}{16}$  inch in thickness and have teeth cut on them to mesh with the teeth on the cylinder gears. On one side of the vibrator gear a blank space of 1 tooth is left; on the other side, diametrically opposite, a blank space of 4 teeth is left. The vibrator gear is free to turn on a pin placed in the end of the vibrator lever  $b_1$ , which is fulcrumed on a rod  $b_2$ . A connector  $b_3$  pivoted at a point near the outer edge of the vibrator gear connects the harness jack  $c$  with the gear. A hard steel "run," or "chill,"  $b_4$  is riveted on the vibrator lever at a point where it will come in contact with a pattern chain  $d_1$ , which is supported by a chain cylinder  $d$ .

This pattern chain is constructed, according to the weave desired in the cloth, of small rolls called *risers* and washers called *sinkers*, which are threaded on spindles connected by links and held together by cotter pins passed through holes in their ends. The chain cylinder is rotated so that one bar of the pattern chain is brought under the runs of the vibrator levers for each pick of the weave. The action of the mechanism is as follows: Whenever a roller is brought under the vibrator lever, the latter is lifted and consequently raises the vibrator gear pinned to its extremity, thus bringing it in contact with the top cylinder gear  $a$ , which is constantly rotating. The cylinder gear turns the vibrator gear about  $\frac{1}{2}$  revolution, or until the blank space of 4 teeth is brought on top. This movement of the vibrator gear causes the point to which the connector  $b_3$  is connected to move from one dead center to the other, thus drawing the connector and jack  $c$  in toward the head-motion and raising the harness, which is attached to the jack as shown by the dotted lines. It should be noted that this part of the drawing is not to scale; that is, it is reduced in size as compared with the shedding mechanism. A small rod  $c$ , passing just above the hubs of the jacks prevents their coming off the rod  $c$ ,

when raising the harness. The vibrator gear continues to keep the harness raised as long as rollers come under the run of the vibrator lever, but should a washer be substituted, the vibrator lever and gear would be lowered, and the latter coming in contact with the bottom cylinder gear  $a$ , would be turned until the blank space of 4 teeth was at the bottom, where it would remain until another roller was brought up. This would have the effect of forcing the pin to which the connector is fastened to the other side of the vibrator gear, thus forcing the connector and jack toward the loom and lowering the harness. In Fig. 4 the vibrator gear is shown in the position it assumes when a washer is brought under the vibrator lever; the bottom cylinder gear is just starting to turn the vibrator gear and lower the harness.

There is a semicircular slot in the vibrator gear with which a steadying pin  $b$ , riveted in the vibrator lever engages. This pin, together with the length of the slot in the vibrator gear governs the extent of movement of the gear and prevents its momentum or any other cause from throwing the gear beyond the proper stopping place.

**5. Lock-Knife.**—A device for locking the vibrator levers in position while the cylinder gears are turning the vibrator gears, prevents the vibrator gear from being forced out of contact with the cylinder. This device consists of a **lock-knife**, or long steel blade,  $e$ , fastened by castings  $e_1$  to a shaft  $e_2$  in such a position that it will engage with the ends of the vibrator levers. The lock-knife not only locks the vibrator levers that are down, but by coming between them and the vibrator levers that are raised, locks every vibrator lever so that the vibrator gears that are lowered are held in contact with the bottom cylinder gear, and those that are raised in contact with the top cylinder gear. The lock-knife is moved from contact with the vibrator levers when a new bar of the chain is about to be forced under them by means of a cam  $e$  fastened on the shaft of the bottom cylinder gear. This cam operates a cam-follower  $e_1$ , that is setscrewed to a casting  $e_2$ , fastened on the shaft  $e_2$ .



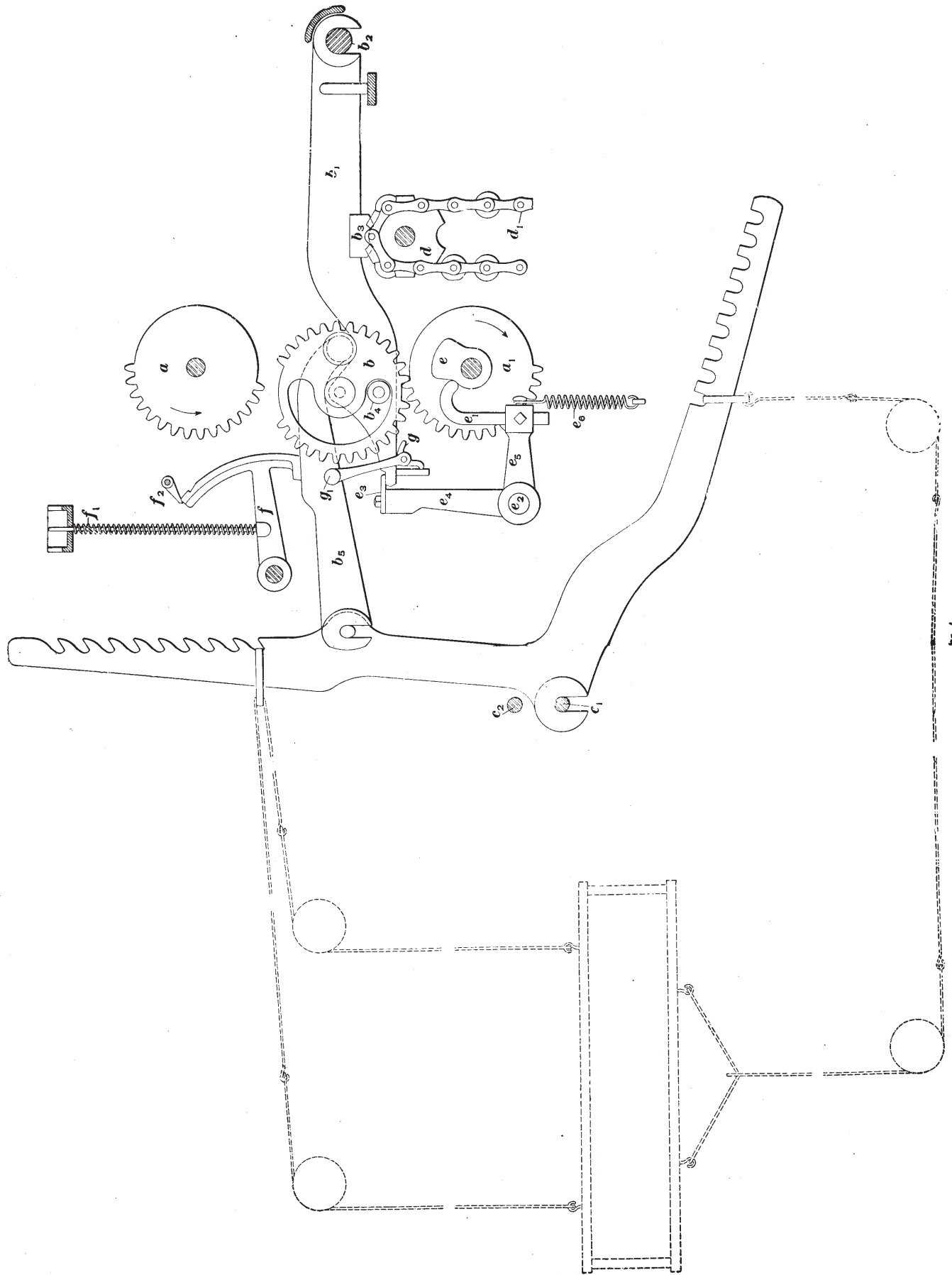

FIG. 4

Double-page spread rotated 90° to fit on page.

A spring  $e_0$  keeps the cam-follower  $e_1$  in contact with the cam  $e$  at all times.

The timing of the lock-knife is important, since if it were to remain in contact with the vibrator levers when a riser is forced under the run, the levers or lock-knife would be bent or broken. It should be set so as to be just moving from contact with the vibrator levers when a new bar of the chain is being forced under the runs. When the cylinder gear engages the first tooth of the vibrator gear the lock-knife should have engaged with the ends of the vibrator levers. The cam  $e$  is fastened to the shaft with a pin and is not movable, but by moving the cam-follower  $e_1$  in the casting  $e_0$  an adjustment sufficient for timing the lock-knife may be obtained. If  $e_1$  is lowered, the lock-knife will be timed earlier, and if raised, it will commence to move later.

**6. Follower Levers.**—When this head-motion is run at high speed there is some danger of the vibrator gears rebounding between the two cylinder gears. In order to prevent this there is a separate hammer, or follower-lever,  $f$  for each connector. This lever is pressed on the connector by a spring  $f_1$  threaded on a rod passing through a hole in a bar at the top of the head-motion. Small latches, or pawls,  $f_2$  for each lever are placed on a rod running across the head, so that any of these levers may be raised and held away from the connector by engaging the latch with a notch in the lever. This is necessary when it is desired to remove the vibrator lever and connector from the loom for repairs or other purposes, and also when it is desired to run the loom with part of the vibrators out, in which case the latch will prevent the lever from dropping down and allowing the rod and spring to fall out.

**7. Harness-Leveling Device.**—With an open-shed loom it is difficult for the weaver to draw in broken warp ends, because the heddle eyes are not all on one level. To obviate this difficulty a harness-leveling device is generally applied to open shedding motions. This device consists of an eccentric bar  $g$  located just beneath the vibrator levers and arranged to be turned on an axis, by means of a handle  $g_1$ ,

in such a manner as to raise all the vibrator levers so that the vibrator gears will be in contact with the top cylinder gear exactly as though risers were brought under each vibrator lever. After raising the vibrators in this manner, if the head-motion is moved 1 pick, after disconnecting it from the rest of the loom, as will be explained later, all of the harnesses will be raised to the level of the top shed, thus enabling the weaver to easily draw in any broken ends.

**8. Driving the Head-Motion.**—The head-motion is driven from the crank-shaft of the loom by means of a gear  $h$ , that engages with a gear  $h_6$  on a stud, as shown in Fig. 5. On the side of the gear  $h_6$  teeth are arranged as for a bevel gear; these engage with a bevel gear  $h_5$  that is loose on the upright shaft  $h$ . Motion is imparted to this shaft by means of a pin  $h_8$  attached to a loose collar  $h_3$ , but extending through a boss  $h_4$  fastened to the shaft and into a hole in the gear  $h_6$ . Fastened to the upright shaft are two bevel gears  $h_2, h_1$  that mesh with the gears  $a_2, a_3$ , respectively, setscrewed to the shafts of the top and bottom cylinder gears  $a, a_1$ , to which motion is thus imparted. As stated, this drive is generally from the crank-shaft of the loom, but on some looms the upright shaft is driven from the bottom shaft; the arrangement of the gears is practically the same, however, in each instance.

It very often happens that it is necessary for the weaver to disconnect the driving mechanism of the head-motion and turn the latter by hand, as, for instance, when finding the correct pick on which to start the loom after a pick-out, etc. This may be accomplished by means of a handle  $j$  bolted inside the frame of the loom and connected to a yoke  $j_3$  by a rod  $j_1$  and arm  $j_2$ . The yoke engages with a groove in the collar  $h_3$ , which it raises when the handle  $j$  is drawn forwards. When the collar  $h_3$  is raised, it withdraws the pin  $h_8$  from contact with the gear  $h_6$ , which allows the shaft  $h$  to turn loosely and the shedding mechanism to be operated by means of the hand wheel  $a_6$ , Fig. 6 (*a*), without interfering with any other part of the loom.

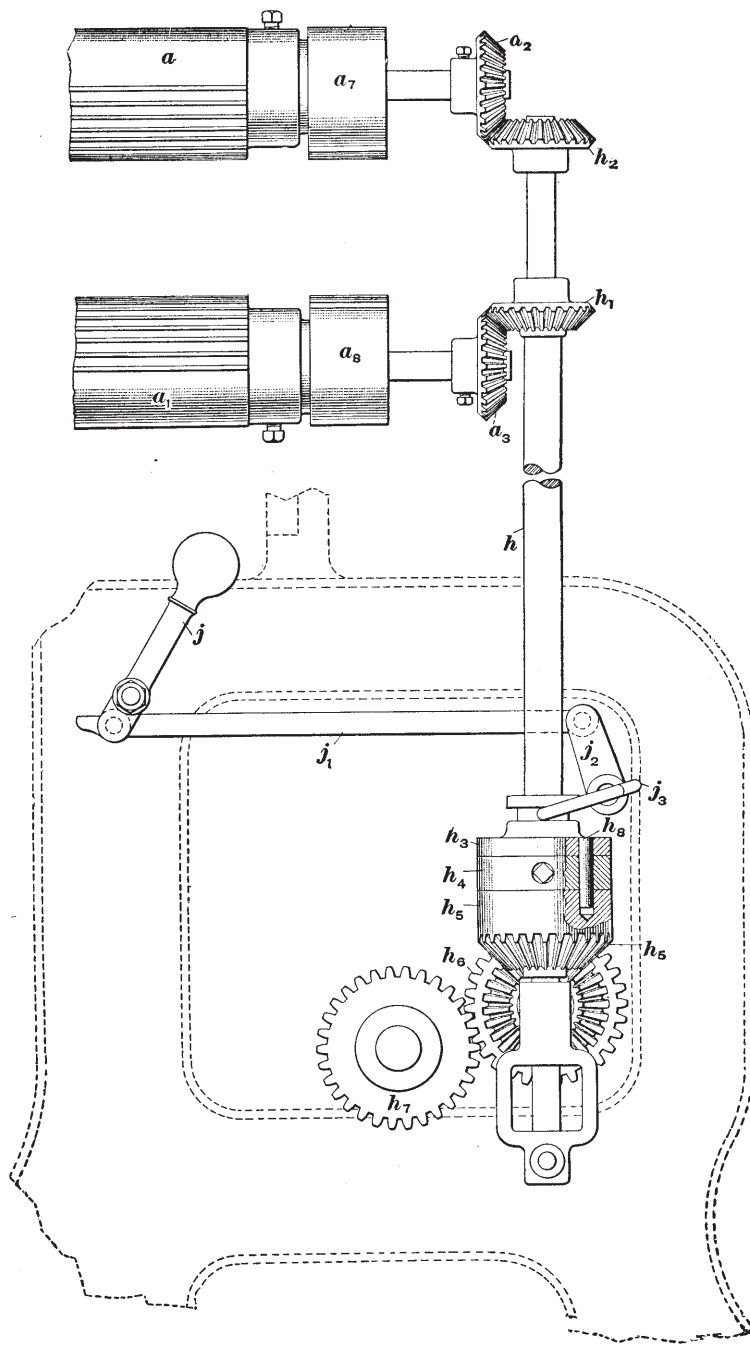

FIG. 5

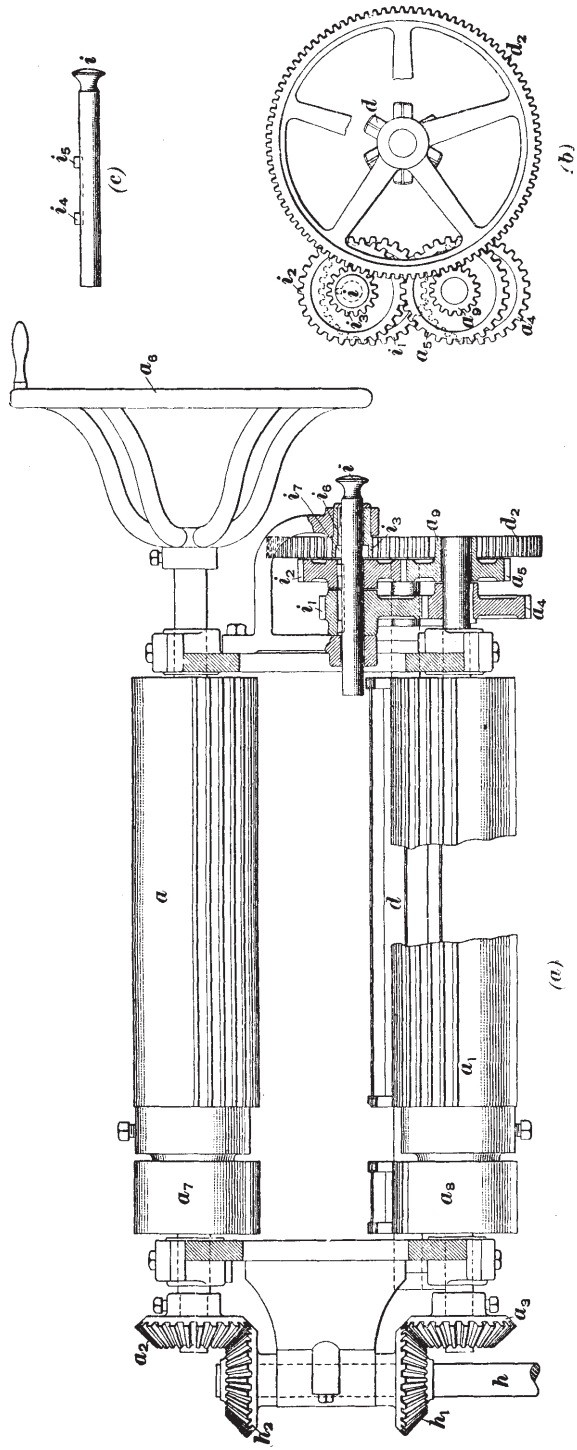

FIG. 6



**9. Chain-Cylinder Drive.**—The chain cylinder, which carries the pattern chain and presents each bar in succession to the runs of the vibrator levers, is driven from the bottom cylinder-gear shaft, as shown in Figs. 3 and 6 (*a*) and (*b*). An eccentric gear  $a_4$  keyed to the shaft of the bottom cylinder gear drives an eccentric gear  $i_1$  carried on a sliding key  $i$ , to which it imparts a rotary motion. Another gear  $i_2$  on the sliding key imparts motion to a gear  $a_5$ , that is loose on the shaft of the bottom cylinder gear. A gear  $a_5$  compounded with this gear drives a gear  $d_2$  that is fastened, usually with a soft setscrew, to the shaft of the chain cylinder  $d$ . Sometimes when the pattern chain is stiff, either because the chain stuff is new or because the chain is gummed up, it will gather in a bunch and prevent the chain cylinder from turning. When this happens the soft setscrew in the gear  $d_2$  will break and allow the gear to turn without imparting motion to the chain cylinder, otherwise a serious smash would be made in the head-motion, which would cause extensive repairs, while the soft setscrew can be easily replaced.

The reason for inserting a pair of eccentric gears  $a_4, i_1$  in the train that drives the chain cylinder is to secure a variable motion of the chain. When a new bar is being forced under the runs of the vibrator levers, the speed of the chain is fast, so that the bar may come into position as quickly as possible; but after the bar has raised and lowered the vibrator levers, so that the vibrator gears are in contact with the cylinder gears, the motion is very slow, in order to allow the vibrator gears to be operated and the harnesses changed before the bar leaves the chain cylinder and another bar is forced in position.

On some looms the variable motion of the chain cylinder is not obtained by eccentric gears  $a_4, i_1$  located in the head itself, but instead the gears  $h_7, h_8$ , Fig. 5, are made eccentric. In this case the whole head-motion is eccentric, but when the motion is geared as shown in Fig. 6 (*a*) and (*b*), the chain cylinder only has an eccentric movement, the cylinder gears rotating at a constant rate of speed.

**10. Reverse Motion.**—There is a device for reversing the direction of rotation of the chain cylinder, so that the loom may be turned over by hand and the chain run backwards, opening the sheds in reverse order and enabling the weaver to find the correct pick whenever this has been lost through the filling running out or a part of the cloth having been picked out. This is accomplished by means of the sliding reverse key  $i$ , Fig. 6 (*c*), which consists of a round pin having two projections  $i_4$ ,  $i_5$  and a knob head that may be readily grasped by the weaver when it is desired to reverse the chain. The projection  $i_4$  is constantly engaged with a keyway cut in the gear  $i_1$ , whether the sliding key is drawn in or out, owing to the width of the gear; it therefore imparts a constant rotary motion to the key. The projection  $i_5$  may engage with a keyway in the gear  $i_2$  if the key is pushed entirely in, or it may engage with a keyway  $i_6$  in the gear  $i_3$ , if the key is drawn entirely out, while if the key is only partially drawn out this projection will be received by the cupped end  $i_7$  of the gear  $i_3$ , and thus impart motion to neither gear. When the reverse key  $i$  is drawn out as far as it will go, motion is imparted to the chain cylinder through the gears  $a_4$ ,  $i_1$ ,  $i_3$ ,  $d_2$ , which will turn the chain cylinder in the opposite direction from its motion during the ordinary running of the loom, thus enabling the weaver to turn the chain back by means of the hand wheel  $a_6$ , after the head-motion has been disconnected from the driving arrangement. The gears  $a_6$ ,  $a_5$ ,  $i_2$  simply revolve loosely during this operation and have no effect on the driving of the chain whatsoever.

When it is desired to level the harnesses, the driving mechanism of the head is first disconnected and the key  $i$  then partially drawn out so that the projection  $i_5$  just enters the cupped end  $i_7$  of the gear  $i_3$ . The vibrators may now be raised by means of the leveling bar and the head-motion turned with the hand wheel  $a_6$ , which will raise all the harnesses to the top shed. The chain remains at rest in this case, because the sliding key  $i$  does not impart motion to either the gear  $i_2$  or the gear  $i_3$ ; both of these and also the gears  $a_6$ ,  $a_5$ ,  $d_2$  remain stationary. By this means the

harnesses may be quickly leveled without losing the pick, since the pattern chain is not displaced, no matter how the head-motion is moved.

**11. Setting the Reverse Gears.**—In placing the gears of the head-motion together, care should be taken that they are arranged so that the setting pins will come in the correct position. These *setting pins* are small pins inserted in the mesh between 2 teeth on one gear and engaging with a hole cut in the center of the tooth of the other gear. This arrangement is used on gears where it is necessary that they should be set in a definite relation to each other. It happens sometimes, however, that the setting pins have been destroyed and there is no guide to set the gears by. To set the reverse gears, even if the setting pins are knocked out, the following method may be employed: Disconnect the driving clutch of the loom and turn the head-motion until the finger that operates the lock-knife is in the exact center of the cam, and the lock-knife at its farthest position from the vibrator levers. Then turn the pattern-chain gear until the vibrator gears are raised so that they are exactly half way between the top and bottom cylinder gears. The reverse gears may now be put together with all the keyways in a straight line so that the reverse key may be forced in and out without moving the gears in the least.

**12. Fast and Slow Motion for Chain Cylinders.** Another method of imparting an eccentric movement to the chain cylinder is shown in Fig. 7. In this method no use is made of eccentric gears, but instead the characteristic fast and slow motion of the chain is obtained by a peculiar construction of the gear  $d_2$  on the chain-cylinder shaft. This gear is constructed with as many sections of teeth spaced equidistant around its circumference as there are recesses in the chain cylinder for the reception of the chain bars. Between each section of teeth is a notch, or cut-out, that is engaged by a pin  $k$  fastened to a plate  $k_1$  screwed to the gear  $k_3$ . A mutilated pinion gear  $k_2$  is made in one piece with the plate  $k_1$  and contains nine teeth, which mesh with

the sections of 10 teeth in the gear  $d_2$ ; as the gear  $k_2$  rotates, therefore, the gear  $d_2$  will be alternately driven by the mutilated pinion  $k_2$ , which imparts a very slow motion, and by the pin  $k$  engaging with a cut-out, which imparts a fast motion to the chain cylinder. When a bar of the chain is just starting to raise the vibrator levers, the first tooth of the mutilated pinion should be just commencing to engage

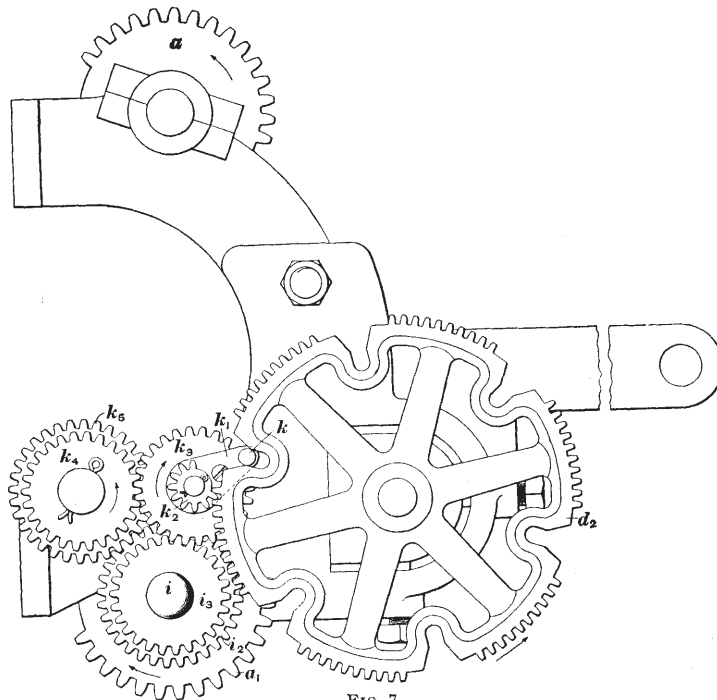

FIG. 7

with a section of the teeth on the gear  $d_2$  and the pin should be moving out of the cut-out; but when the bar of the chain starts to leave the vibrator levers, the pin should commence to engage with the next cut-out, while the mutilated pinion should be just leaving the section of teeth.

The reverse gears are arranged in a slightly different manner in this arrangement for driving the chain cylinder than in that previously described. The shaft of the bottom

cylinder gear  $a_1$  is key-seated and carries a sliding reverse key  $i$  that has only one projection, which may engage with either the gear  $i_2$  or the gear  $i_3$ . When the key is pushed in and the loom running in the ordinary manner, the gear  $d_2$  on the shaft of the chain cylinder is revolved in the direction of the arrow, in consequence of being driven through the gears  $i_2, k_5, k_4, k_3$ ; but when the reverse key is drawn out so that its projection engages with the gear  $i_3$ , it is driven in the reverse direction by means of gears  $i_3$  and  $k_3$ , the gears  $k_4, k_5, i_2$  turning loosely.

---

**HARNESSEVENER MOTION**

**13.** There is often considerable difficulty on broad looms in strapping the harnesses so that the yarn will be at the same height in respect to the race plate on each side of the loom. There is a tendency for the side farthest from the shedding motion to be lower than the other side; and in some cases the difference becomes so great as to cause the yarn to drag on the race plate on one side, while on the other side it is so high as to give the shuttle an upward tendency when entering the shed, which is liable to throw it from the loom. Even if the harness is strapped correctly at first, the strap operating the farther end of the harness will stretch more than that operating the nearer end, on account of its greater length. This difficulty may be confined to only a few harnesses, in which case it is more difficult to remedy than if all the harnesses are affected alike.

In order to prevent this trouble, a special arrangement is made for connecting the harness to the jack on broad looms, as shown in Fig. 8. A shaft carrying pulleys having extended arms  $l, l_1$  is placed between the two arches of the loom in the center of the reed space. The arm  $l$  has two hooks, to one of which a strap or wire  $l_2$  attached to the jack of the shedding motion is fastened, while to the other is fastened a strap  $l_3$  passing over the sheave  $l_4$  to the harness. On the arm  $l_1$  is a single hook, to which is fastened a strap  $l_5$  that passes over the sheave  $l_6$  and is attached to the other end of the harness. It will be seen that the arms  $l, l_1$  form



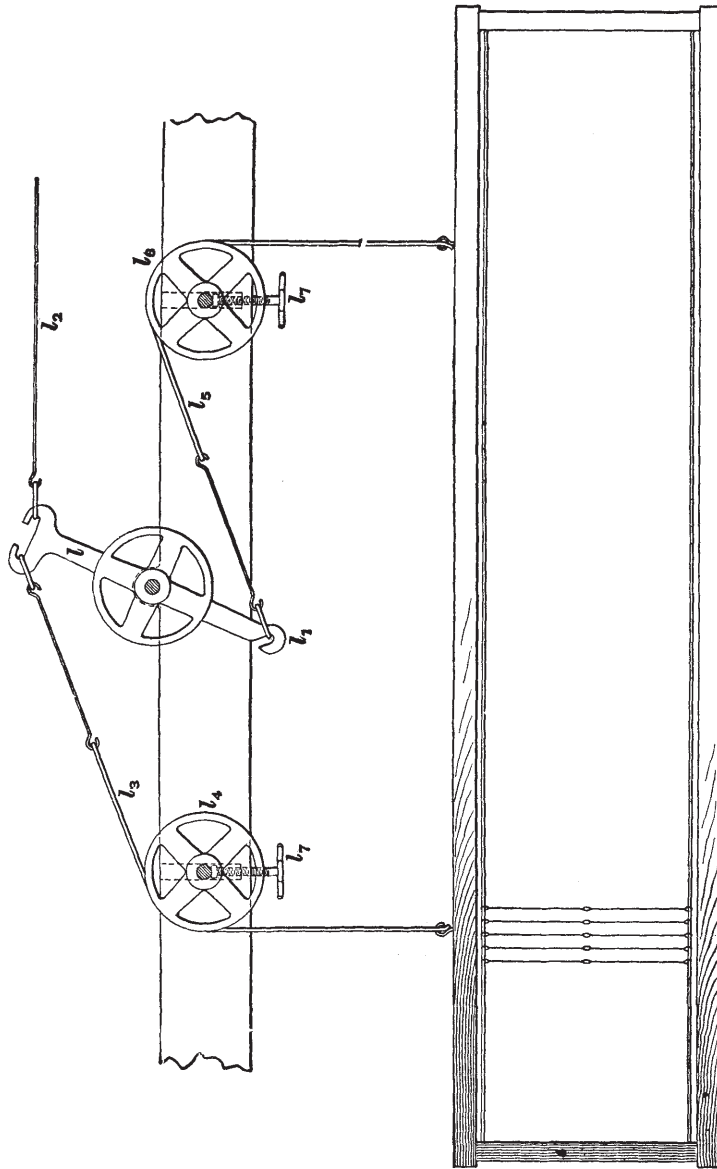

FIG. 8

a lever, which when turned on its fulcrum, by the shedding motion acting through  $l_2$ , will impart an equal movement to each end of the harness, as the arms are of the same length. The object of the pulley form of this lever is simply to strengthen the extended arms, which are subjected to considerable strain in transmitting the motion of the shedding mechanism to the harnesses. The straps  $l_3, l_5$  being of the same length, will stretch equally if any stretch takes place. The sheaves  $l_4, l_6$  are carried on shafts extending across the two arches and are provided with adjustment screws  $l$ , whereby the sheaves may be raised or lowered should all the harnesses become too high or too low on either side of the loom.

#### BUILDING HARNESS CHAINS

14. As has been stated, a harness may be raised on any pick by placing a roller, or lowered by placing a washer, on the pattern chain in such a position that it will come under the vibrator lever governing that harness. Since this is the case, any harness may be raised and lowered in any order desired, and any selection of harnesses to be raised on any pick may be made. The order of lifting and lowering the harnesses is generally made out by the designer on design, or point, paper and is known as a **pattern-chain draft**, or simply a **chain draft**. It is the duty of those engaged in the weave room to build the harness, or pattern, chain so that the harnesses will be lifted in the manner indicated by the designer's chain draft.

To illustrate the method of accomplishing this, suppose that it is desired to build a harness chain so that the harnesses will be lifted according to the draft shown in Fig. 9. This draft consists of filled, or black, spaces, representing a harness raised, and empty spaces, indicating a harness lowered. Each horizontal row of squares, or those passing across the draft, represents 1 pick of the weave, or one bar of the harness chain; each vertical row of squares corresponds to a vibrator lever and the harness controlled by it and shows the manner of lifting that harness. Thus, if it is desired to raise any particular harness on any pick, a mark

is placed on the vertical row of squares corresponding to that harness and on the pick on which it is desired to lift the harness. It will be seen, therefore, that the horizontal rows of squares indicate the harnesses that are raised or lowered on each successive pick, while the vertical rows of squares represent on what picks each individual harness is to be raised and lowered. Usually, instead of filling in the squares, the designer simply marks the squares with a cross or dot.

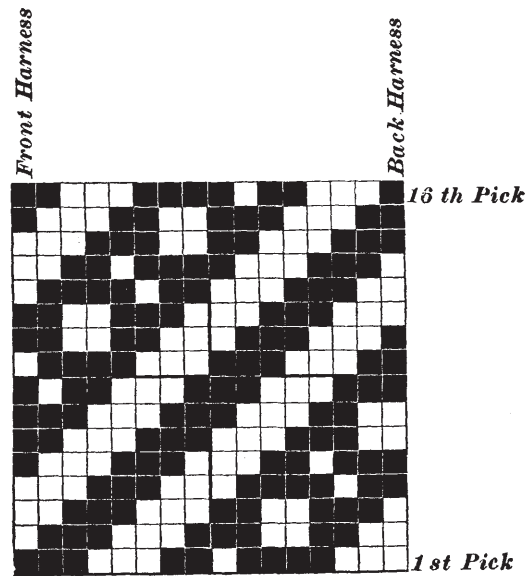

FIG. 9

When building a pattern chain, it is important to know which is the first pick of the draft and which vertical row of squares represents the first, or front, harness. This is usually indicated on the draft by the designer in some arbitrary manner, sometimes by placing a cross at the corner of the draft. If not indicated, it is safe to assume that the horizontal row of squares at the bottom represents the first pick and the vertical row of squares at the left the manner of operating the first harness at the front of the loom. The pattern chain must be so built that the bar representing the

first pick will be the first to be presented to the chain cylinder and the sinkers or risers operating the first harness will be at the front of the loom.

Shedding mechanisms are sometimes placed on the right-hand side of the loom and sometimes on the left, and in building pattern chains for looms in which the construction of the pattern chain is not such that it will permit both sides to run on the chain cylinder, these points must be taken into consideration. In building pattern chains for the Knowles head-motion, or for any similar shedding mechanism in which the construction of the pattern chain is such that either side may be run on the chain cylinder, it is not necessary to take so many precautions. In this case all that is necessary is to read the chain draft and build the chain from left to right. It makes no difference whether the bottom horizontal row of squares of the chain draft representing the first pick is the first bar of the chain built and the next to the bottom the second bar, etc. since the pattern chain for a Knowles loom may be reversed end for end. Fig. 10 shows the chain built after this manner for the draft in Fig. 9 in the position it would be when placed on the loom, and as shown is arranged to be applied to a loom with the head-motion on the right-hand side; but if desired to be placed on a loom with the head-motion on the left, all that would be necessary would be to turn the chain over and run the other side to the chain cylinder. It will be readily understood that the above statements in regard to building chains for the Knowles loom are correct if the construction of the chain is remembered. This construction, with circular rollers threaded on round spindles, is such that there is no right side to the chain, and the back may be used for the front or the front for the back, the chain being placed on the loom in any desired position. It will be noted particularly, however, that the chain must be placed on the loom in the correct position so that the bar representing the first pick will be first presented to the vibrator levers and the bar representing the second pick next brought under them, etc. The construction of the chain shown in Fig. 10 should be noted.

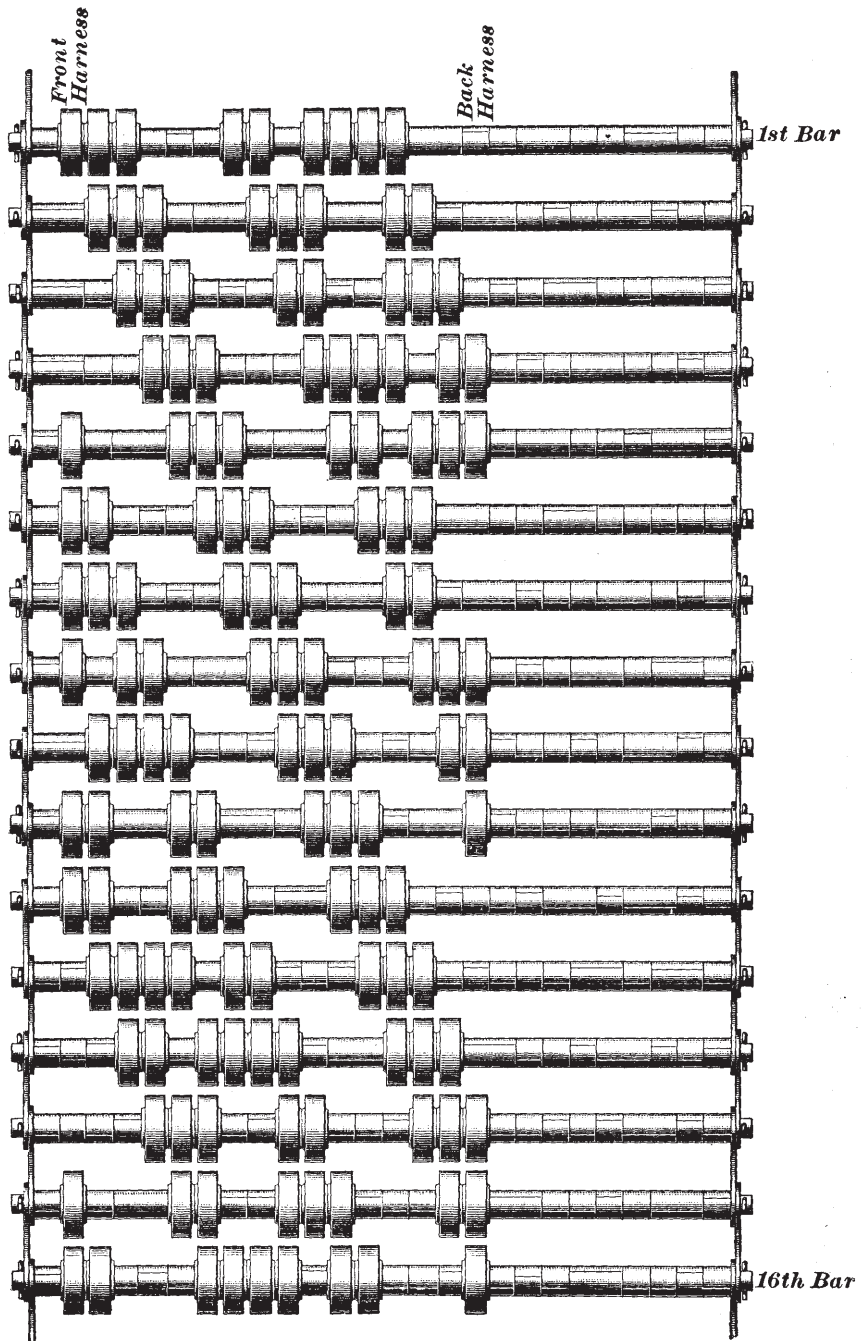

FIG. 16



## BOX MOTION

**15.** The great majority of the looms employed in weaving woolen and worsted fabrics, and especially those in which fancy patterns are developed, are what are commonly known as  $4 \times 4$  pick-and-pick looms; that is, there are four shuttle boxes on each side of the loom and each picker stick is thrown in at every revolution of the crank-shaft. By this arrangement it is not only possible to operate more than one shuttle (which is impossible with a single-box loom), but it is possible to drive the shuttle from either side of the loom at any pick, thus allowing a single pick of any color of filling to be inserted in the cloth. This latter is impossible with that type of looms having movable boxes on one side only and a single fixed box on the other—known as  $4 \times 1$ ,  $6 \times 1$  looms, etc.—since the shuttles must always come to rest on the box side of the loom and any shuttle can therefore place only an even number of picks in the cloth.

The object of the **box motion** is to allow shuttles carrying different kinds or colors of filling yarn to be presented to the picker in a definite order of rotation so that the required filling pattern will be woven into the cloth. There are two types of box motions—the *rotary* and the *drop-box motions*, the latter being by far the more widely used and in fact the only motion applied to American-built looms. In a drop-box loom a number of shuttle boxes are constructed one above the other and placed at one or both ends of the lay, being operated by a suitable mechanism so that any box may be raised or lowered until it becomes level with the race plate and the shuttle that it contains is in position to be operated on by the picker.

**16.** The Knowles  $4 \times 4$  box motion, which is applied to the fancy loom shown in Figs. 1 and 2, raises and lowers the boxes of the loom by means of a simple mechanism; the desired motion is obtained by means of cylinder gears and vibrator gears in exactly the same manner as the harnesses are operated. Fig. 11 is a perspective view of the box

motion as seen from the rear of the loom. Four vibrator gears  $b_4$  are placed between two cylinder gears  $a_7, a_8$  that are setscrewed to the harness cylinder gears  $a, a_1$ , the ends of the latter being recessed so that the box cylinder gears may

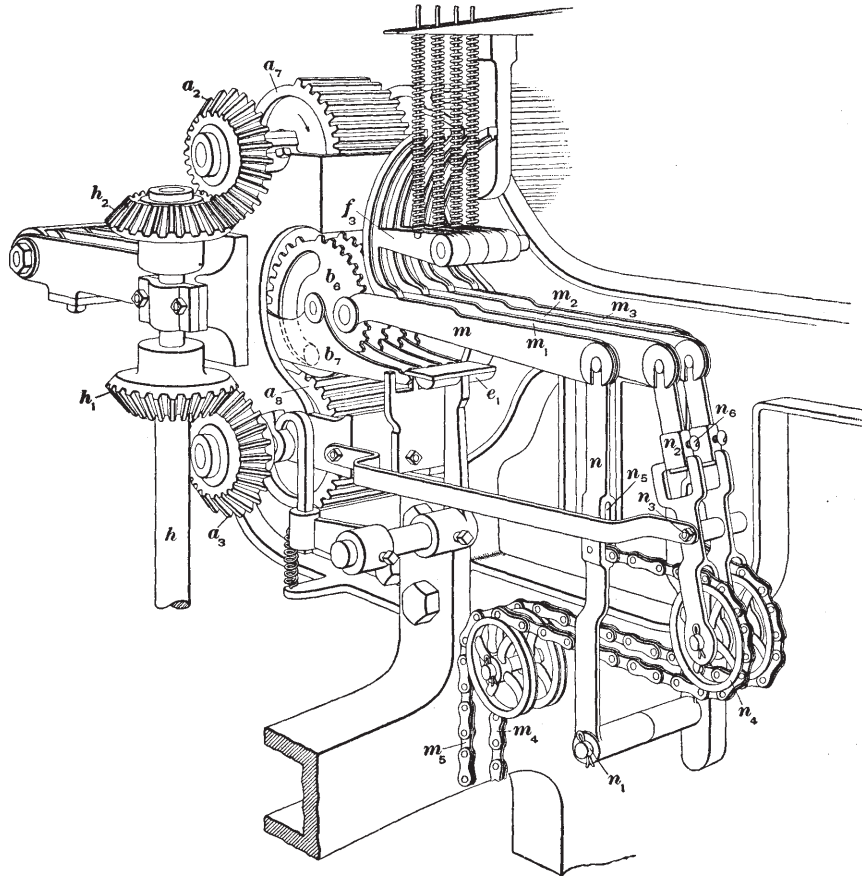

FIG. 11

be inserted in them for a distance of 2 or 3 inches, see Fig. 6 (a). By fastening the box cylinder gears in this manner, it is possible to change their position in relation to the harness cylinder gears so that the boxes can be made to

operate earlier or later with reference to the shed. The vibrator gears have vibrator levers  $b_r$  and connectors  $m, m_1, m_2, m_3$  and are operated by a box chain built of risers and sinkers in exactly the same manner as the harness chain, except that it is narrower, being only wide enough to carry four rollers or washers to operate the four box vibrator levers. The mechanism is so connected to the boxes that the two vibrators on the right of a person standing at the side of a loom and facing the head-motion operate the boxes on the right-hand side of the loom, while the two vibrators on the left operate the boxes on the left-hand side. Of each of these two the outside vibrators, to which the connectors  $m, m_3$  are fastened, are arranged to raise the boxes on their respective sides of the loom the distance of one box, while the inside vibrators, to which the connectors  $m_1, m_2$  are attached, will raise the boxes the distance of two boxes. If both vibrators that operate the boxes on one side of the loom are raised, so that the connectors  $m, m_1$  or  $m_2, m_3$  are operated, the boxes on that side of the loom will be raised the distance of three boxes, or from the first to the fourth, but if both are left down the first box will be level with the race plate. This is not due to any difference in the length of the throw of the connectors, but to the method of operating the lifting chains  $m_4, m_5$  that transmit the motion of the vibrators to the boxes on each side of the loom.

In explaining the method of accomplishing this, reference will be made to the method of operating the chain  $m_5$  that operates the boxes on the right-hand side of the loom, since the chain  $m_4$  is operated in exactly the same manner by the two vibrators on the left. The chain  $m_5$  is attached to a lever  $n$  fulcrumed on a stud  $n_1$  and also attached to the connector  $m$ . If the vibrator gear to which  $m$  is fastened is raised by a roller on the box chain, it will come in contact with the top cylinder gear  $a_r$  and receive a half revolution, thus drawing in the connector  $m$  and the top of the lever  $n$  and, as the chain is attached to this lever, raising the boxes. The distance that the chain is moved in this instance will be exactly enough to give the boxes a lift of one box. Suppose,

however, that the second vibrator gear, which is fastened to the connector  $m_1$ , is raised, the connector  $m_1$  will draw in the top of the lever  $n_2$ , which is fulcrumed at  $n_3$  and carries a loose flange pulley  $n_4$  around which the box chain is passed. This motion of the lever  $n_2$  will have the effect of forcing out the pulley  $n_4$  and giving the box chain and boxes just twice the lift that was given in the former case. It will be readily seen that if both vibrator gears were raised, the boxes would receive the combined lift of both levers, or three boxes. Since the boxes on the other side of the loom are operated in the same manner, it will be seen that any one of the four boxes on either side may be called to the race plate by placing proper risers and sinkers on the box chain. There is a separate lock knife  $l_1$  fastened on the same shaft as the lock knife for the shedding mechanism, for the purpose of locking the box vibrator levers while the vibrator gears are being turned by the cylinder gears. Each box vibrator connector is provided with a hammer, or follower lever,  $f_2$  exactly the same as those used in the shedding motion, to prevent the vibrator gears from rebounding.

As previously stated, the motion of the box levers is communicated to the boxes by the lifting chains  $m_4, m_5$ , which pass over idle pulleys  $m_{11}$ , Fig. 2, and are connected to the boxes as shown in Fig. 12. It will be noted that although the connections between the box levers and the boxes are spoken of as chains, they really consist of chains combined with rods wherever it is not necessary for the chain to run over a pulley. Both lifting chains  $m_4, m_5$  are brought to the front of the loom around two pulleys  $m_6$ , from which the chain for the boxes on the right passes over pulleys  $m_7, m_8$ , while the chain for the boxes on the left passes over a pulley  $m_9$ , across the loom just beneath the lay, and over a pulley  $m_{10}$ . The boxes  $o$  are free to move in a vertical direction between guides at the ends of the lay, and at the bottom of each set of boxes a lifting, or box, rod  $o_1$  is fastened. The box chain is fastened to a casting  $o_2$  that is loose on the lifting rod, and the boxes are supported on a strong spring  $o_3$  resting on this casting. The object of connecting the box chains to the

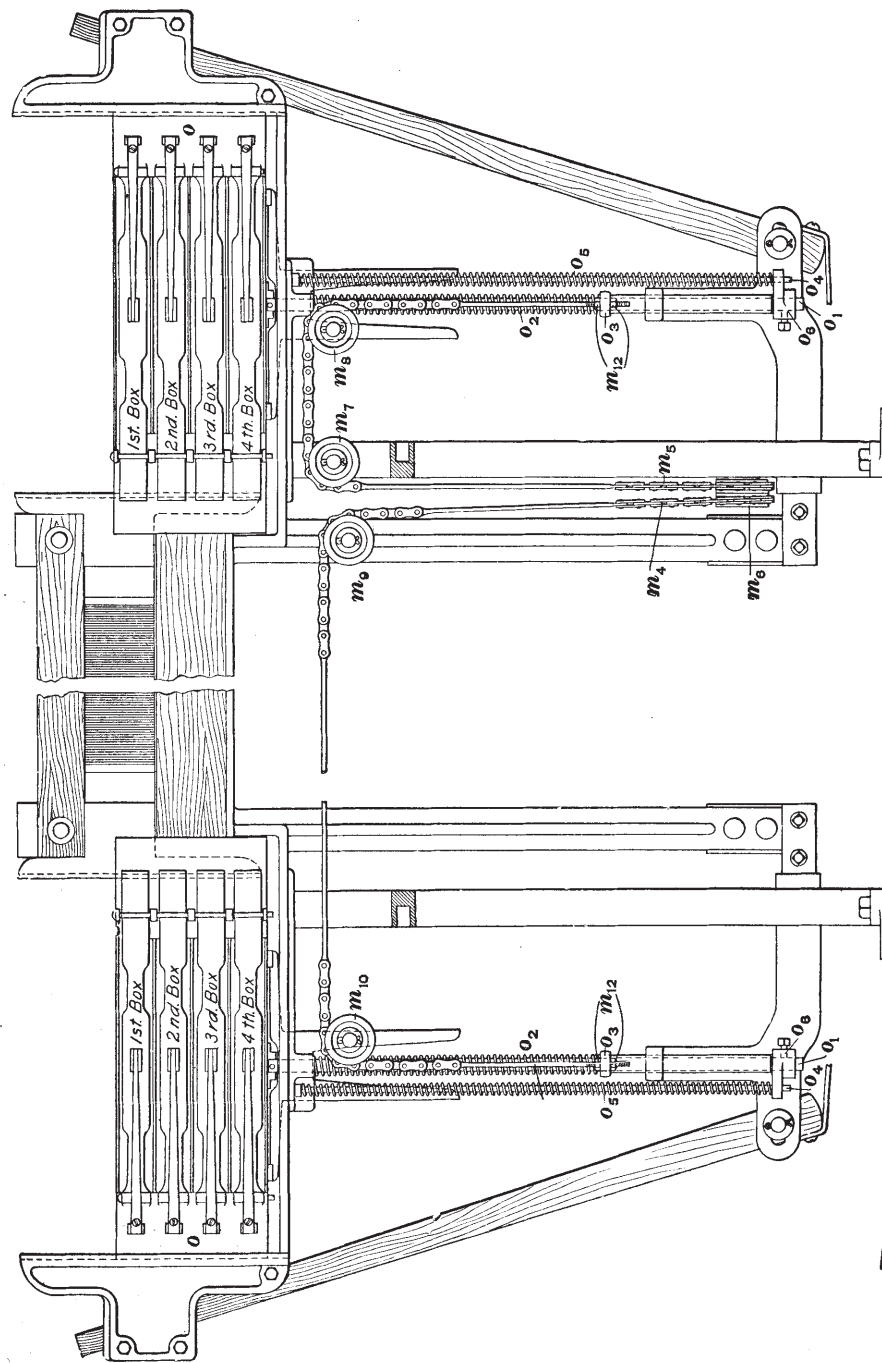

FIG. 12

boxes in this manner is to prevent any breakage, since if the boxes become caught or the picker does not get back far enough to clear the slot in the box before the latter commences to lift, the spring will be compressed.

**17.** While the shedding motion is positive, raising and lowering the harnesses, the box motion is non-positive, simply raising the boxes. The boxes are lowered by their own weight aided by a spring  $o_s$  on a rod  $o_r$  that is fastened to the lay at its upper end, while its lower end extends through a casting  $o_c$  setscrewed to the lifting rod. As the boxes are raised the spring is compressed, and as the vibrator slackens the chain when the box is to be lowered the spring aids the weight of the boxes in bringing them down. It will also be seen that there would be some liability of the boxes rising slightly above the race plate and falling back again when lifted if it were not for this spring, which prevents vibration of the boxes and makes their motion smooth and reliable.

---

#### MULTIPLIER

**18.** When a large number of picks of one color are to be inserted in a fabric, it is of great advantage if a loom is equipped with some mechanism whereby the box chain can be stopped for a certain length of time, holding the boxes stationary while those picks are being placed in the cloth. Such a mechanism is known as a **multiplier motion**, since it does away with the necessity of building long and heavy box chains, by multiplying the number of picks that certain bars will place in the cloth.

The Knowles multiplier is shown in Fig. 13. The box chain is carried on the box-chain cylinder  $d_4$ , which is fastened to a sleeve  $d_5$  loose on an extension  $d_3$  of the shaft of the harness-chain cylinder; a star gear  $d_6$  is also fastened to this sleeve. Another sleeve  $p$ , which also is loose on the shaft  $d_3$ , carries another star gear  $p_2$  and the multiplier-chain cylinder  $p_1$ . Two sliding pieces  $q, r$  are placed on a sleeve  $s_2$  on a stud  $s$ . The sleeve  $s_2$  is driven from the gear  $a_6$  by means of a gear  $a_{10}$ , Fig. 1, a shaft  $a_{11}$  extending across the

head, a gear  $a_{12}$ , and a gear  $s_1$  fastened to the sleeve. This sleeve is geared so that it makes one revolution at each pick of the loom, and the sliding pieces  $q, r$  are keyed to it so as to have a rotary motion imparted to them by the shaft and still be capable of being slid along the shaft so that the pins  $q_3, r_1$  will engage with or be disengaged from the star gears. This lateral motion of the sliding pieces is obtained by means of two yokes  $q_2, r_2$  that engage with grooves in them and are setscrewed to two sliding rods  $q_3, r_3$ . The

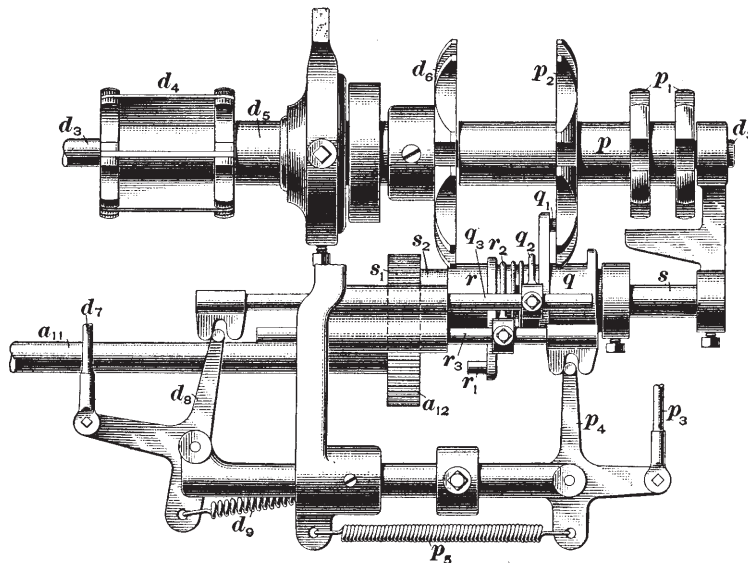

FIG. 13

sliding rod  $q_3$  is operated by means of a rod  $d_7$  and a lever  $d_8$  engaging with a notched piece on the end of the rod. The rod  $d_7$  is raised by means of a long spindle with which each bar of the box chain that is to be multiplied is built, as shown in Fig. 16; this spindle is forced under the run of a lever to which the rod is attached, when that bar of the chain is brought under the vibrator levers of the box motion. It should be particularly noted that only those bars of the box chain that are to be multiplied are built with the long



spindle, bars that are not to be multiplied being built with a spindle only sufficiently long to pass through the links that hold the chain together. The rod  $r_3$  is operated by a lever  $p_4$  and a rod  $p_3$  that is connected to a lever, shown in Fig. 2, operated by risers on a multiplier chain placed on the multiplier-chain cylinder  $p_1$ . The multiplier chain, shown in Fig. 17, is built of spindles joined by links exactly the same as the box and pattern chains, except that the multiplier chain is only wide enough to contain one riser for raising the rod. It may be built in any manner that is desired, the number of bars indicating the number of picks that will be placed in the cloth before the boxes will change again; for instance, if the multiplier chain is made with five sinkers and one riser, 6 picks will be placed in the cloth before the box chain moves; if built with nine sinkers and one riser, 10 picks will be inserted, etc.

**19.** The action of the multiplier is as follows: After the box and multiplier chains have been built they are placed on their respective cylinders. Each bar of the box chain that is to be multiplied is built with a long spindle projecting under the lever that raises the rod  $d_7$ . Suppose that the multiplier chain is built with nine sinkers and one riser so that it will multiply the bar of the box chain ten times. During the ordinary running of the box chain, it is driven so that one bar is moved under the box vibrator levers at each pick of the loom by means of the pin  $r_1$  that is fastened to the sliding piece  $r$  on the shaft and engages with the cut-outs in the star gear  $d_6$ . While the box chain is in operation, the riser on the multiplier chain remains stationary directly under its vibrator lever, so that the rod  $p_3$  that is attached to this lever will remain in its highest position and keep the pin  $r_1$  in contact with the star gear  $d_6$ . When a bar having a long spindle is brought up, the end of the spindle raises the rod  $d_7$ , which throws the pin  $q_1$  on the sliding piece  $q$  into the cut-outs of the star gear  $p_2$ , thus starting the multiplier chain. At the same time, the riser on the multiplier chain moving from under the lever that

holds up the rod  $p_1$ , allows the spring  $p_5$  to pull down the rod and disengage the pin  $r_1$ , that has been driving the box chain. The loom now runs 10 picks (or any other number, according to how the multiplier chain is built) with one bar of the box chain under the box vibrator levers. When the riser on the multiplier chain comes around again, the rod  $p_3$  is raised and the pin  $r_1$ , being thrown in contact with the star gear  $d_6$ , starts the box chain again; at the same time, the rod  $d_7$ , being lowered as the lever passes off the end of the long spindle allows the spring  $d_8$  to pull the pin  $q_1$  from contact with the star gear  $p_2$  and stop the multiplier chain. The loom will now continue to run and the box chain to revolve in the ordinary manner until another bar built on a long spindle is brought around.

---

#### TIMING THE BOX MOTION

**20.** To time the box motion, the lay is first brought forwards so that the dagger of the protector motion is up to the frog under the breast beam. Have the clutch at the bottom of the upright shaft locked and loosen the setscrews that fasten the small spur gear to the crank-shaft of the loom. Arrange the box motion so that the boxes will receive their full lift, that is, from the first to the fourth box; then turn the head-motion forwards by means of the crank on the top cylinder-gear shaft until the boxes rise so that when there is no shuttle in the top box the binder of the second box will just touch the protector finger, which should raise the box about  $\frac{1}{4}$  inch. This times both the box and harness motions, but if at any time it is desired to change the timing of the shedding motion so that the harnesses will start earlier or later with reference to the box motion, it is simply necessary to loosen the setscrews in the harness sections of the cylinder gears and turn them forwards or backwards, taking care that the same change is made in both the top and bottom cylinder gears; that they always stand in the same relative position; and that the starting teeth always engage the teeth of the vibrator gears at exactly the same time. This does not disturb the box motion in any way and no further adjustment is necessary.

## LEVELING THE BOXES

**21.** In leveling boxes on a Knowles  $4 \times 4$  loom, it is best to first level all the boxes on one side of the loom before beginning on the boxes on the other side. The method usually adopted is to begin with the boxes on the head end of the loom. The method of procedure is as follows: First bring the top, or first, box exactly level with the race plate by adjusting it with the nuts  $m_{12}$ , Fig. 12, on the small wrought-iron rod, which is riveted to the end of the chain  $m_s$  near the lower end of the box rod. Then move the boxes from the first to the second box by raising the lever  $n$ , Fig. 11. Loosen the nut that holds the end of the chain  $m_s$  in place in the slot  $n_s$  in the lever  $n$  and adjust the second box by raising or lowering the end of the chain in the slot, according to whether more or less motion is wanted. Then bring the first box level with the race plate again, as the adjustment of the second box may have thrown out the first box a trifle. Keep moving the boxes from the first to the second until both are exactly right; then move from the first to the third by raising the lever  $n_2$  and adjust the third box by loosening the setscrew  $n_s$  and moving up or down the upper arm of the lever until the box is level. Keep moving the boxes from the first to the third until both are exactly right, since the adjustment of the third box may have thrown out the first. Next raise both levers together for the fourth box. If the other boxes are right, the fourth box should be level with the race plate without further adjustment. If not, the motion of the boxes may have to be divided a little. A very slight change in the lever  $n_2$  that brings the third box level with the race plate will be found to make a considerable difference. The boxes on the opposite side of the loom are adjusted in exactly the same way by making similar adjustments on the levers that operate them.

In leveling the box, it will save considerable time to put on a box chain built especially for this purpose so that it will be only necessary to move the box-chain cylinder a bar or two in order to get the box desired.

Sometimes the chain that connects the boxes with the box mechanism becomes worn in some places more than others on the side that runs on the guiding sheave pulleys. When this is the case, difficulty is sometimes experienced in leveling boxes; in such cases, it is well to take off the chain and turn it over, letting the other edge run on the pulleys.

#### BUILDING BOX CHAINS

**22.** In building box chains for pick-and-pick looms, that is, looms in which both picker sticks are thrown in at each pick, considerable care must be exercised in order to prevent smashes. For instance, if the chain were built so that boxes containing shuttles were presented to both pickers at the same time, the result would be that the shuttles would meet in the shed, where one would probably be deflected, and flying from the loom would be liable to break out the warp or do other damage. Sometimes both shuttles will strike each other squarely and stop dead in the shed; in this case the protector usually stops the loom so as to prevent a smash, but the shuttle points are usually so badly battered as to render it necessary to have them ground down. Should the protector fail to work in a case like this, the worst smash possible will result, since the warp will be broken out for a distance equal to the length of two shuttles. Therefore, it will be seen that in building box chains for pick-and-pick looms it is of vital importance to have an empty box on one side of the loom at each pick. In cases where five and six shuttles are run in looms having only four boxes on each side the difficulty of arranging the box chain so as to accomplish this will be recognized, since there can be, in the case of five-shuttle work, only three empty boxes, and with six shuttles only two empty boxes. Care should also be taken to build the box chain so that there will be as few jumps, that is, movements of two or more boxes, as possible, as this places undue strain on the loom and causes it to absorb more power. Jumps or drops of two boxes, that is, from the first box to the third or the second to the

fourth or vice versa, are not too hard on the loom and in building many box chains must be used, but jumps from the first to the fourth or drops from the fourth to the first box should always be avoided, and in the great majority of filling drafts there is no necessity for them. If a movement of two boxes must be made, it is always better to arrange the chain so that a drop will be made rather than a jump.

**23.** To illustrate the method of building a box chain, suppose that it is desired to build a box chain to operate five shuttles in a Knowles  $4 \times 4$  loom, the colors to be placed in the cloth after the manner indicated by the filling draft in Fig. 14. The best method of building a chain and a method that will not render mistakes liable to occur is to rule two sets of squares as shown in Fig. 15, each set to contain as many vertical rows as there are boxes on that side of the loom. The set of squares on the left in Fig. 15 represents the boxes on the left of the loom, while that on the

<i>Red</i>	4		4								1											= 8		
<i>Brown</i>		8		2		5		2		5								5		2		5	2	= 36
<i>Orange</i>						1		1														1	1	= 4
<i>Fawn</i>								1		1		2		1		1								= 6
<i>Green</i>													1		1									= 2
<i>Total Number of Picks in Pattern</i>																						<b>56</b>		

FIG. 14

right represents the boxes on the right of the loom. The vertical rows in each set are numbered at the top to represent the boxes; thus, the vertical row of squares in the set of squares on the left, marked 1, represents the top, or first, box on the left of the loom, while the vertical row in the set of squares on the right, marked 2, represents the second box on the right of the loom, etc. The colors of filling carried by the shuttles are indicated by their initial letters. If more convenient a piece of design paper may be used, but in either case it is desirable to leave a sufficient space between the two sets of squares for representing the box chain, which will also require four vertical rows of squares.

When starting the chain, any color may be placed in any box, but it is always best to place them so that the chain can

be made with as few jumps as possible. As shown in Fig. 15, the shuttle that carries the red filling has been placed in the first box on the left-hand side of the loom and the brown in the second box. On the other side of the loom the orange has been placed in the first box, the fawn in the third, and the green in the fourth. Referring to Fig. 14, it will be seen that the pattern first calls for 4 picks of red to be placed in the cloth. The shuttle that contains the red is therefore passed across the loom from the first box on the left-hand side to the second box, which is the only empty box on the other side, and back again four times, working from the top of the vertical rows of squares downwards and utilizing as many horizontal rows of squares as there are picks inserted, in this case 4. This is indicated by the crosses on the squares representing those boxes, each horizontal row of squares representing 1 pick. It will be noticed that the square in which the shuttle was left after the 4 picks had been inserted is marked *R*. This must be done with each color, since it affords a means of quickly telling in which box each color was left and prevents arranging

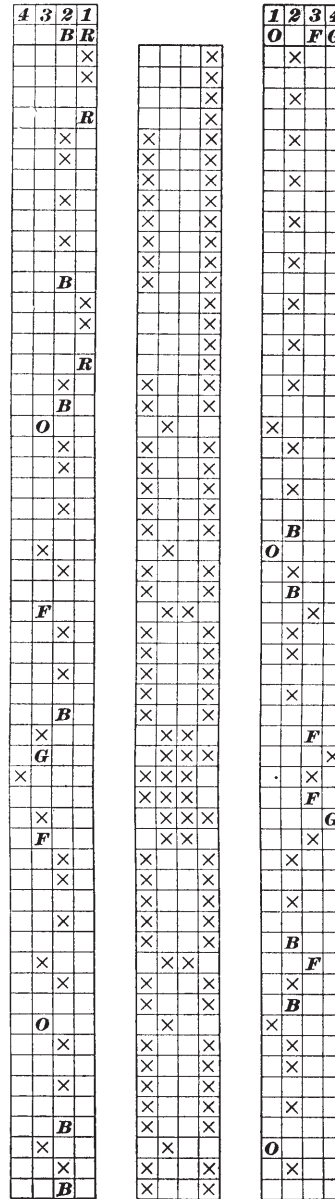

FIG. 15

for another shuttle to be thrown into that box. Next, 8 picks of brown are inserted, the shuttle passing back and forth between the second boxes on each side, and so on, each color being called according to the filling draft. The crosses indicate the box into which the shuttle is thrown at the completion of each pick with the exception that whenever a new color is introduced a cross is placed on the first pick of that color in the square representing the box that the shuttle starts from, as well as in the square representing the box that the shuttle enters at the completion of the pick. For instance, on the first pick of the draft, where red begins, a cross is placed in the square representing the first box on the left, where the shuttle starts, as well as in the square representing the second box on the right, where the shuttle rests at the completion of the pick. In the same way on the fifth pick, which is the first pick of brown, crosses are placed to indicate the box from which the shuttle starts and the box in which it rests after that pick. An important point to be noted is that when the draft is completed all the shuttles must be left in the boxes in which they started, even if it is necessary to build a repeat of the chain; otherwise a smash is sure to occur. It will be noted that in Fig. 15 there are no jumps or drops, the shuttles on either side moving only one box between any colors, and also that the colors are all left in the boxes in which they started.

**24.** Having worked out a good system of operating the boxes, it is a comparatively easy matter to arrange the box chains to lift the desired boxes. This may be done on four vertical rows of squares between those representing the boxes at each end of the loom. It will be assumed that the first vertical row of squares at the left on which the box chain is to be shown represents the vibrator lever that raises the second box on that side of the loom and the second lever raises the third box. For the boxes at the other side, the first lever at the right will raise the second box and the second lever from the right the third box. It will be remembered that two washers operating both levers that



govern the boxes on either side will call the first box on that side and that two rollers will call the fourth box on that side. Each horizontal row of squares across the box chain represents a pick of filling or one bar of the box chain; consequently, to indicate how the box chain is to be built, it is simply necessary to indicate what levers are to be raised in order to call the boxes indicated on the drafts at each side. For instance, on the first 4 picks the second box on the right and the first box on the left are called; on the next 8 picks the crosses indicate that rollers must be placed on the chain to call the second boxes on each side, and so on. When building the chain it should be noted which box vibrators operate the boxes on each side of the loom, and care should also be taken when placing the shuttles in the loom to start them on the proper side and in the proper boxes; otherwise a smash cannot be avoided.

**25. Multiplier.**—By referring to the filling draft in Fig. 14 it will be seen that a 4-pick multiplier (that is, one built with every fourth bar a riser) will save the most bars. Therefore, in every part of the box chain where there are four successive bars calling the same boxes, only one is necessary, this being threaded on one of the long multiplier bars. Fig. 16 shows the appearance of the completed box chain for the draft in Fig. 14, and Fig. 17 shows the multiplier chain that would be used. Two repeats of the latter, as shown, would be necessary in order to encircle the multiplier-chain cylinder on the loom. It will be noted that if this chain were to be built without utilizing the multiplier motion, or for a loom without a multiplier motion, as many bars would be required as there are picks in the pattern, in this case fifty-six bars; but by building the short multiplier chain,

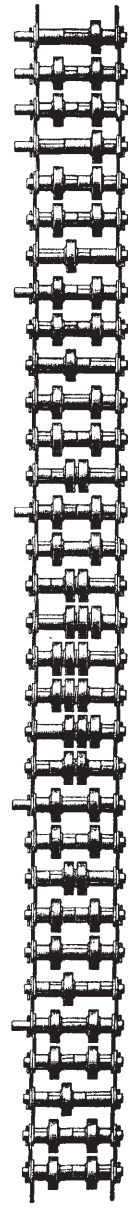

FIG. 16

Fig. 17, the boxes may be operated by a box chain of only thirty-two bars, as shown in Fig. 16. On many patterns the amount of labor saved in building the box chain would be much greater than in this particular case.

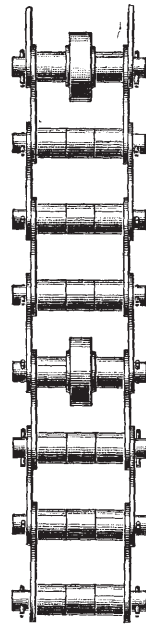

FIG. 17

### PICKING MECHANISMS

#### EQUALLY AND UNEQUALLY GEARED PICKING MOTIONS

**26.** The picking motion on box looms having drop boxes on each end of the lay is generally arranged to operate both pickers at each revolution of the crank-shaft, so that the shuttle may be thrown in either direction on any pick. There are two methods employed to accomplish this result.

In the first method the crank- and bottom-shaft gears are made with the same number of teeth, so that the bottom shaft will make a revolution to each revolution of the crank-shaft. In this case both pick balls are fastened on the same side of the bottom shaft, and both will consequently strike their respective picking shoes simultaneously. Looms having this arrangement are known as **equally geared looms**.

In the second method the gear on the bottom shaft has twice as many teeth as the gear on the crank-shaft, so that the former makes only 1 revolution while the latter makes two. In order to throw each picker stick in at every revolution of the crank-shaft, it is necessary in this case to have two pick balls on each side of the loom. These, of course, are set diametrically opposite each other, so that one ball on each side of the loom will throw each picker stick in at every half revolution of the bottom shaft. Looms having this arrangement are known as **unequally geared looms**.

Aside from the arrangement of the gearing and pick balls there is no other difference in the picking motions of equally

and unequally geared looms except in the shape of the picking shoe. In the former case, the picking shoe has a slow, easy curve, owing to the speed at which the pick ball moves, but in the latter case the picking shoe has a sharper and quicker curve, so that the slower speed of the pick ball may impart a blow of sufficient strength to throw the shuttle across the loom.

For very broad looms, the equally geared picking motion is to be preferred, since the greater speed of the pick ball enables a greater impulse to be imparted to the shuttle by means of a properly shaped shoe, but for narrow looms the unequally geared motion gives a smooth, steady pick, provided that both pick balls are equidistant from the center of the bottom shaft. If an unequally geared loom has only one pick ball on each side, it is not a pick-and-pick loom, but is known as an **alternate pick loom**. In this case the pick balls must be set diametrically opposite each other so that the picker sticks will work alternately, one being thrown in on one pick and the other on the next, and so on. This motion is generally used on single-box looms.

---

#### SLIDING PICK MOTION

**27.** Many Knowles pick-and-pick looms are equipped with the **sliding pick** arrangement, which is a mechanism applied to the picking motion by means of which it is possible to operate the picker sticks alternately, either stick being thrown in for one or as many picks as desired, while the other remains at rest. For instance, suppose that four shuttles are to be thrown from one side of the loom to the other in succession; with the sliding pick arrangement this side of the loom can be made to pick four times while the picking motion on the other side of the loom remains at rest for an equal number of picks. Or, on the other hand, suppose that one shuttle is to be thrown back and forth across the loom for a number of picks, the picking motion on each side of the loom can be made to operate alternately. No matter how the filling pattern is arranged or at which side of

the loom the next shuttle to be picked is at rest, with this motion it is only necessary on any pick to operate the picking motion on the same side of the loom as the shuttle that is to be thrown, leaving the other picking motion at rest. By this means not only is the amount of wear and tear on the picking motions reduced by one-half, but the liability of bad shuttle smashes is also eliminated, since when only one picker stick is in operation, it is impossible for two shuttles to meet in the center of the shed.

An illustration of the sliding pick mechanism as arranged for an unequally geared loom is shown in Fig. 18 (*a*). The picking balls  $k_7, n_7$  are mounted on arms  $k_6, n_6$  loosely supported on the bottom shaft of the loom, but having the characteristic rotary motion imparted to them by means of projections  $k_8, n_8$  that extend into slots in the castings  $k_9, n_9$ , Fig. 18 (*b*), keyed to the bottom shaft. The hubs of the arms that support the pick balls are grooved so as to be engaged by yokes  $r_4, r_5$  connected by a rod  $r_6$ . The yoke  $r_4$  forms part of an elbow lever  $j_7$ , which when raised will throw the casting  $k_9$  and pick balls  $k_7$  directly over the picking shoe  $k_{10}$ , thus imparting motion to the picker stick on that side of the loom, and at the same time, by means of the rod  $r_6$ , will draw the casting  $n_9$  and pick balls  $n_7$  from the picking shoe  $n_{10}$ , so that the pick balls, although still revolving, will not impart motion to the shoe and picker stick on that side of the loom. When the lever  $j_7$  is depressed, the motion will be reversed and the loom will pick from the other side, while the picking motion that was previously in operation will remain at rest. Motion is imparted to this mechanism by means of an extra, or fifth, vibrator gear  $b_8$  placed between the box-motion cylinder gears  $a_7, a_8$  of the head-motion. This vibrator gear is operated by risers or sinkers placed on the box chain so as to raise or lower the vibrator lever  $b_8$ , and imparts motion to the connector  $b_{10}$ , which is connected to one arm of an elbow lever  $j_4$ ; a casting  $j_5$  is fastened to the other arm of the elbow lever  $j_4$  and supports a rod  $j_6$  connected to the previously mentioned elbow lever  $j_7$ . By means of this arrangement, a riser on

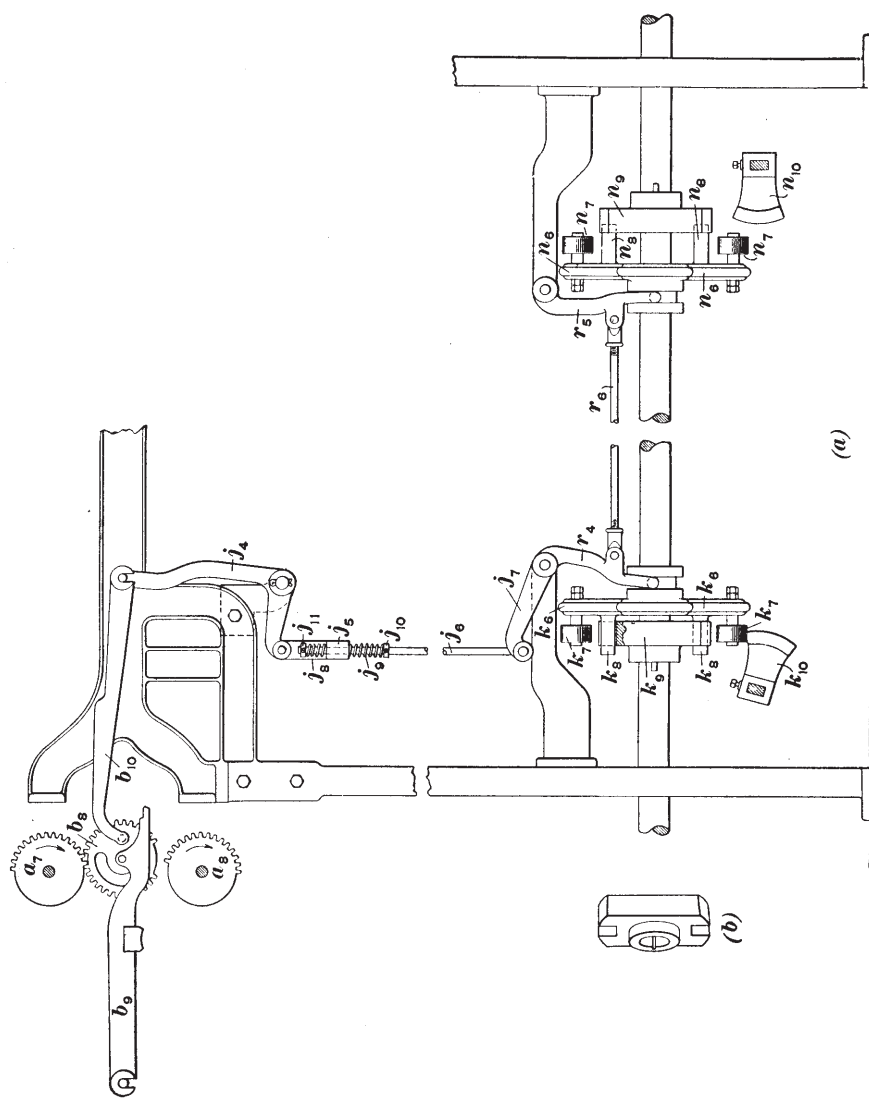

FIG. 18

the chain will throw the picking motion in on one side and out on the other, while a sinker on the chain will reverse the action. The rod  $j_6$  is not fastened in a fixed position to the casting  $j_5$ , but passes through a hole in the same and is held in position by two springs  $j_8, j_9$  and adjustable collars  $j_{10}, j_{11}$ . This makes an elastic connection in each direction that will prevent any breakage of the parts in case the motion is operated when the loom is stopped with the bottom shaft in such a position that the pick ball will strike against the side or edge of the picking shoe.

---

### TAKE-UP MECHANISMS

---

#### THE RATCHET RING TAKE-UP MOTION

**28.** Fancy woolen and worsted looms are sometimes equipped with positive and sometimes with conditional take-up motions. The take-up motion applied to the loom shown in Fig. 2 and illustrated in detail in Fig. 19 is known as the **ratchet ring take-up motion** and may be arranged as either a positive or a conditional motion, as desired.

When this style of take-up motion is employed, the cloth passes from the breast beam around the take-up roll  $v$ , over a loose iron roll  $v_1$ , and is finally wound on the cloth roll  $w$ . The loose roll  $v_1$  is for the purpose of leading the cloth around the take-up roll so that a greater surface of the latter will be presented to the cloth. The take-up roll is wound spirally with a strip of thin sheet steel about 2 inches in width punched full of small holes. It is applied to the take-up roll with the rough side out and thus presents a rough, serrated surface that firmly grips the cloth, so that the latter is pulled down over the breast beam positively at a speed depending on the amount of motion imparted to the roll by the take-up mechanism; thus, the speed of the take-up roll governs the picks per inch in the cloth. For light fabrics a take-up roll covered with coarse sandpaper is generally used, since a perforated steel-covered roll would be too harsh and would be liable to damage the fabric.

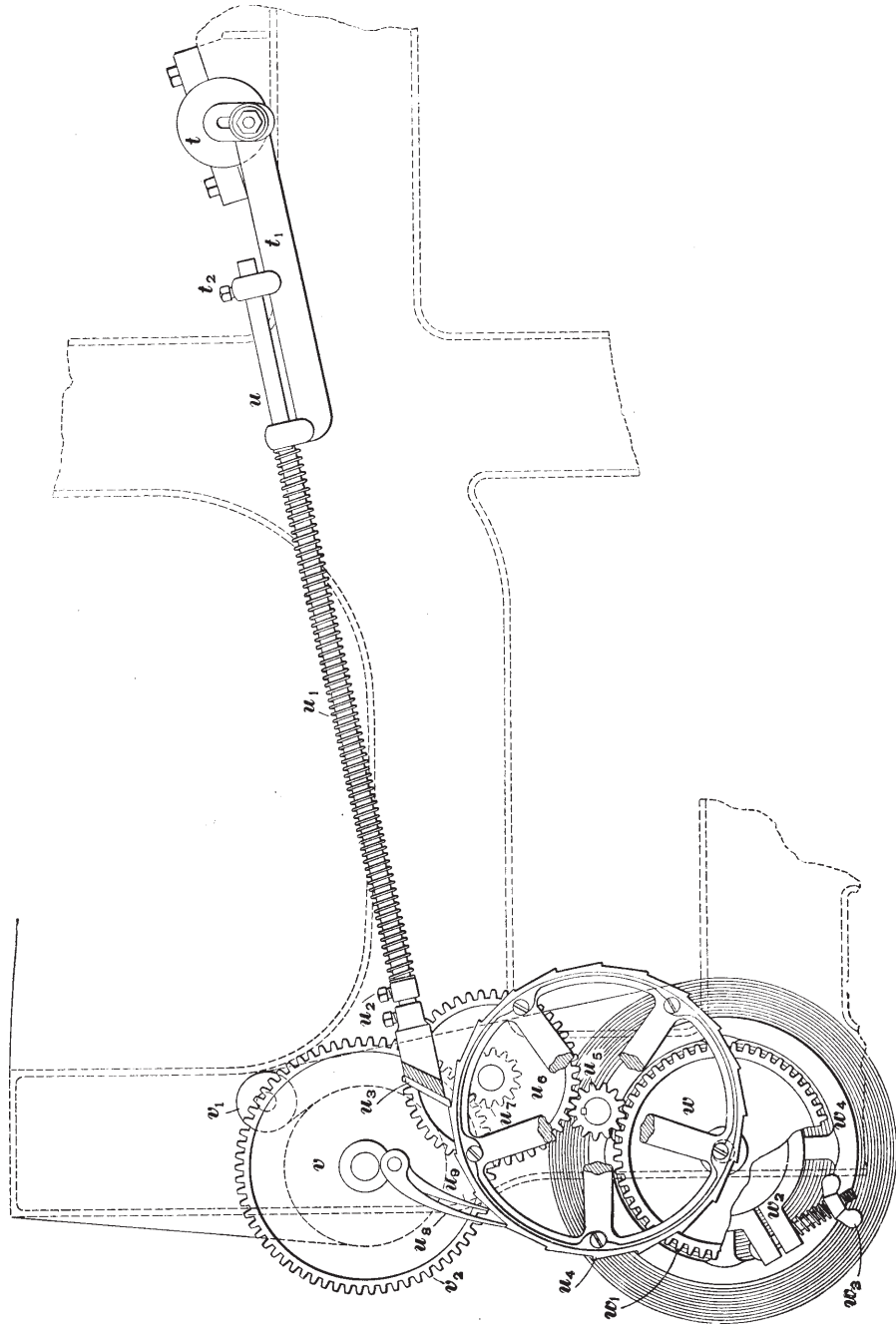

FIG. 19



A roll covered with sandpaper, however, is not suitable for heavy fabrics, since it does not grip the cloth sufficiently to prevent slippage.

Motion is imparted to the take-up roll by means of a slotted disk  $t$  that is fastened to the crank-shaft of the loom. A casting  $t_1$  is fastened eccentrically to this slotted piece and has setscrewed to it a rod  $u$  known as the *pitman rod*. A pawl  $u_3$  bolted to the end of the pitman rod engages with the teeth of the ratchet  $u_4$  fastened to a short shaft carried in a bearing in the frame of the loom. On the other end of this shaft is fastened a gear  $u_5$  that drives the gear  $v_2$  on the take-up roll through the gears  $u_6, u_7$ . As the crank-shaft of the loom revolves, the pitman, being fastened eccentrically to the slotted casting, is worked forwards and backwards, and the pawl engaging with the teeth of the ratchet imparts motion to the same, which is transmitted by the train of gears previously mentioned to the take-up roll, thus drawing the cloth over the breast beam at a uniform rate of speed. During the backward movement of the pitman arm, the ratchet is prevented from moving back by a double set pawl constructed in two parts  $u_8, u_9$ . When one of its parts is engaged with a tooth of the ratchet, the other will rest exactly half way between 2 teeth; by this means the ratchet is prevented from turning backwards if it is thrust forwards for the space of  $\frac{1}{2}$  tooth, since one or the other of the parts of the set pawl will then engage with a tooth of the ratchet.

By means of the slotted casting  $t$  the amount of eccentricity may be so varied that the motion imparted to the pitman arm will be sufficient to move the ratchet so that the set pawls will take up one, two, or in some cases where a ratchet with a large number of teeth is used, three or four teeth. The gearing driving the take-up roll is so reduced that when the throw of the pitman is adjusted so that the ratchet takes up one tooth at each pick of the loom, the number of picks per inch in the cloth will be the same as the number of teeth in the ratchet. If the ratchet takes up 2 teeth, the number of picks per inch in the cloth will be equal to one-half the number of teeth in the ratchet, etc.

Any desired number of picks per inch may be obtained by changing the ratchet for one having the required number of teeth. The rim of the ratchet is made in the form of a ring, which is fastened to the spider with screws, so that it may be removed and a rim having a different number of teeth substituted very readily.

**29.** As fast as the cloth is drawn down by the take-up roll it is wound on the cloth roll  $w$ , to which motion is imparted by means of the gear  $u$ , driving the gear  $w_1$ , which in turn imparts motion to the cloth roll by means of a friction clamp  $w_2$ . The cloth roll is driven slightly faster than is necessary to wind up the cloth, which may be wound with any degree of tension by tightening the thumbscrew  $w_3$ , which tightens the friction on the cloth roll. The tension of the cloth as it is wound on the cloth roll should, however, be slightly less than the tension of the cloth above the take-up roll, so as not to interfere with the motion of the latter, even if there is considerable back lash in the gears. The hand wheel  $w_4$  is for the purpose of operating the roll by hand when the friction is loosened and a cut of cloth is being taken from the loom.

**30.** The ratchet ring take-up motion can be very readily changed to a **conditional take-up** by loosening the setscrew  $t_2$ ; this will bring into action the spring  $u_1$ , which has no function whatever in connection with the positive motion. When the setscrew is loosened, the tension of the cloth tending to turn the take-up roll will compress the spring and move the rod backwards through the holes in the casting  $t_1$ . As the cloth is woven it will lessen the tension, and the spring will gradually force the ratchet forwards a tooth. When this motion is used as a conditional take-up, the number of picks per inch will depend on the tension of the warp, which of course depends on the amount of weight on the let-off motion. The number of teeth in the ratchet will have no control over the number of picks per inch when this motion is used as a conditional take-up, but more even results will be obtained if the ratchet does not have exactly or approximately the same number of teeth as picks per inch in the cloth.

## WORM TAKE-UP MOTION

**31.** The Knowles worm take-up motion, Fig. 20 (a), is frequently used on fancy looms, and while it is not quite as convenient as the ratchet ring take-up, it has one advantage in that it is impossible for the weaver to interfere with it in any way. With the ratchet ring and similar take-up motions dishonest weavers often resort to the practice known as *pumping*, which consists of pushing the take-up ratchet along at intervals so that the cloth will be drawn over the breast beam faster than the take-up motion calls for. By this means the weaver turns off a greater length of cloth in a week, but at the expense of the evenness of the goods, since every time the take-up motion is pumped, a slight thin place is made in the cloth in consequence of fewer picks being inserted in the fabric at that point.

The worm take-up motion is driven from the bottom shaft of the loom by means of a bevel gear  $t$  that drives a bevel gear  $t_1$  fastened on the take-up shaft  $t_2$ . On unequally geared looms, the gear  $t_1$  has one-half as many teeth as the gear  $t$ , but on equally geared looms it is of the same size, so that in either case the take-up shaft  $t_2$  makes one revolution to each pick of the loom. A worm  $u$  fast to a sleeve to which the hand wheel  $u_1$  is also attached, imparts motion to a worm-gear  $u_3$ . This is accomplished by means of the handle  $u_2$ , which when pressed in, as shown in the illustration, engages with cut-outs in the flange  $t_3$  on the take-up shaft  $t_2$ , thus enabling the motion of the shaft to be imparted to the worm. When the handle is pulled out the hand wheel and worm may be turned, and the take-up motion operated by hand, since in this case the worm is loose on the shaft. The motion of the gear  $u_3$  is imparted to the take-up roll  $v$  by a train of gears as shown in Fig. 20 (b), which is a view of the gear-combination as seen from the inside of the loom. The pinion gear  $u_4$  is fastened to the same shaft as the gear  $u_3$  and drives a gear  $u_5$  compounded with a gear  $u_6$ , the latter meshing with the gear  $v_2$ , which is fastened to the take-up roll  $v$ . Of this train of gears,  $u_3$  contains 100 teeth;  $u_4$ , 16 teeth;

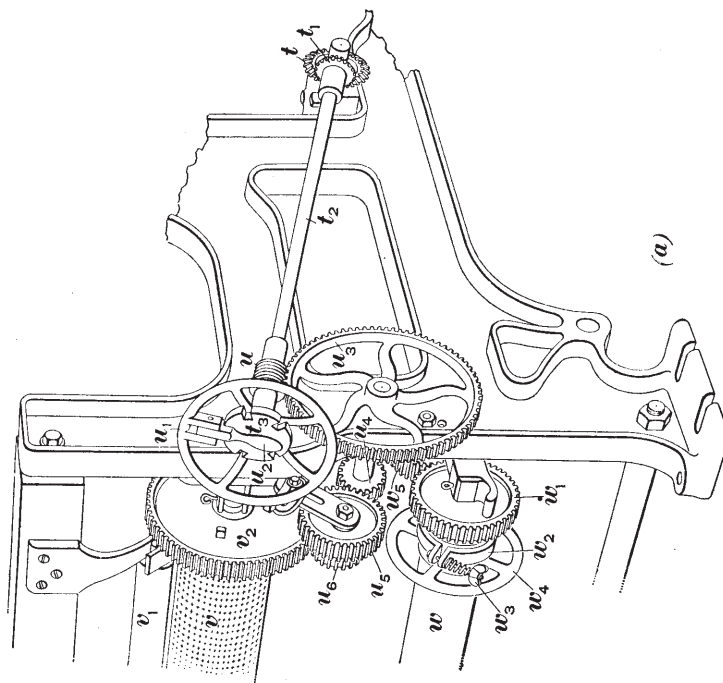
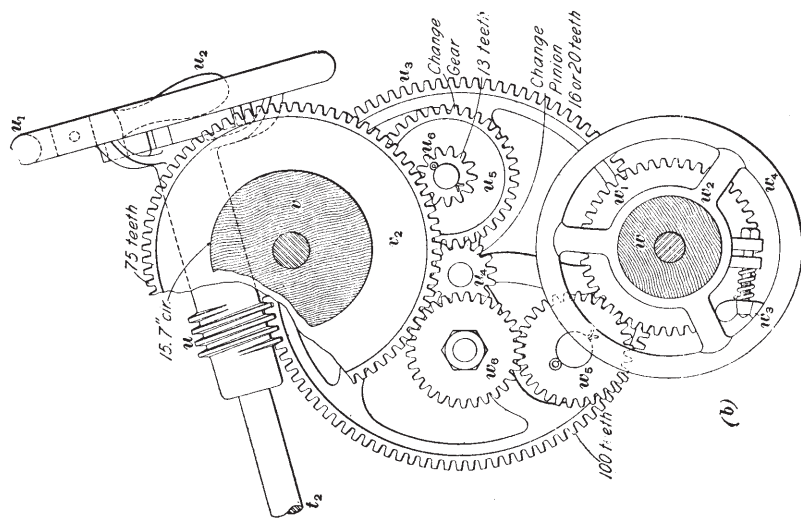

FIG. 20

$u_6$ , 13 teeth; and  $v_2$ , 75 teeth. The gear  $u_6$  is the change gear, the size of which may be altered so as to change the speed of the take-up roll so that the cloth will be drawn over the breast beam of the loom at the rate of speed required to give the desired number of picks per inch in the fabric. In order to find the number of teeth required in the change gear to give a desired number of picks per inch in the cloth, it is best to first find the constant for the train of gears driving the take-up roll. It will be noted that gear  $u_3$  is moved 1 tooth for each pick of the loom, since the worm  $u$  is single-threaded and the shaft  $t_2$  makes 1 revolution to each revolution of the crankshaft. Then to find the constant it is only necessary to divide the product of the number of teeth in gears  $u_3$  and  $v_2$  by the product of the number of teeth in gears  $u_4$  and  $u_6$  multiplied by the circumference of the take-up roll  $v$ , which is 15.7 inches, thus  $\frac{100 \times 75}{16 \times 13 \times 15.7} = 2.296$  constant.

To find the number of teeth required in the change gear, it is only necessary to divide the number of picks per inch required in the cloth by the constant. Thus, if 46 picks per inch are required, a 20-tooth change gear will be necessary, since  $46 \div 2.296 = 20$  (practically). By the reverse process the number of picks per inch in the cloth may be readily ascertained by multiplying the number of teeth in the change gear by the constant. In some cases, the pinion gear  $u_4$  contains 20 teeth instead of 16, which will make the constant for the train of gears 1.837, as shown by the following calculation:  $\frac{100 \times 75}{20 \times 13 \times 15.7} = 1.837$  constant.

Table I shows the number of picks per inch in the cloth with different size change gears using 16- and 20-tooth change pinion gears. The number of picks per inch inserted in the fabric by different combinations of change and change pinion gears as shown in the table is the correct calculated number for average fabrics and conditions, but in some cases a slight variation may be found from the number of picks stated in the table. This is caused by the different rates of contraction exhibited by fabrics of different constructions

TABLE I

Number of Picks per Inch	Pinion Gear Teeth	Change Gear Teeth	Number of Picks per Inch	Pinion Gear Teeth	Change Gear Teeth	Number of Picks per Inch	Pinion Gear Teeth	Change Gear Teeth	Number of Picks per Inch	Pinion Gear Teeth	Change Gear Teeth	Number of Picks per Inch	Pinion Gear Teeth	Change Gear Teeth
26	20	14	57	20	31	81	20	44	112	20	61			
28	20	15	59	20	32	83	20	45	114	20	62			
29	20	16	60	16	26	85	16	37	115	16	50			
31	20	17	61	20	33	86	20	47	116	20	63			
33	20	18	62	16	27	87	16	38	117	16	51			
34	16	15	64	16	28	88	20	48	118	20	64			
35	20	19	66	20	36	89	16	39	119	16	52			
37	20	20	67	16	29	90	20	49	122	16	53			
38	20	21	68	20	37	92	20	50	124	16	54			
39	16	17	69	16	30	94	16	41	126	16	55			
40	20	22	70	20	38	95	20	52	129	16	56			
41	16	18	71	16	31	96	16	42	131	16	57			
42	20	23	72	20	39	97	20	53	133	16	58			
44	20	24	73	16	32	99	20	54	135	16	59			
46	16	20	75	20	41	101	16	44	138	16	60			
48	16	21	76	16	33	103	20	56	140	16	61			
50	20	27	77	20	42	105	20	57	142	16	62			
51	20	28	78	16	34	106	16	46	145	16	63			
53	16	23	79	20	43	108	16	47	147	16	64			
55	16	24	80	16	35	110	16	48	149	16	65			

woven with various weaves when taken from the loom. This is due to the fact that the warp is under tension during weaving, but when taken from the loom, this tension is relieved and the cloth tends to contract. This contraction, of course, increases the number of picks per inch, the actual increase depending on the contraction of the particular cloth under consideration.

The cloth roll  $w$  is driven from the gear  $v_2$  through two intermediate gears  $w_5, w_6$  that impart motion to the gear  $w_1$ . The arrangement of the hand wheel  $w_4$  and friction clamp  $w_2$  is the same as with the ratchet ring take-up motion.

---

#### BRAKE MOTION

**32.** Most fancy looms are equipped with a **brake motion** so that when the filling stop-motion is operated the loom will be stopped immediately. But for some such motion, the momentum of the loom would cause it to run for 3 or 4 picks before stopping, thus making it necessary for the weaver to turn back the head-motion to find the shed in which the pick was broken, whereas with a properly constructed brake motion the loom will in most cases be stopped before the reed reaches the fell of the cloth and with the broken pick in the shed. The brake motion also relieves the strain when the loom *bangs off*, and greatly lessens the liability of broken crank-shafts or lay swords.

The brake motion attached to the fancy loom shown in Figs. 1 and 2 is shown in detail in Figs. 21 and 22. A brake wheel  $x$  is made in one piece with the crank-shaft driving gear, which is keyed to the crank-shaft of the loom. A steel friction band  $x_1$  having a strip of leather riveted to its inner face is fastened to a stud  $x_2$ , passes over the face of the brake wheel, and is connected to a lever  $x_3$  by means of a rod  $x_3$  and an adjustable eyebolt  $x_4$ . Attached to the opposite end of the lever  $x_3$  is an upright rod  $y$  having setscrewed to its upper end a locking piece  $y_1$  that extends through a slot in the casting  $z_1$  fastened to the frame of the loom. A spring  $y_2$ , the tension of which may be adjusted by a movable



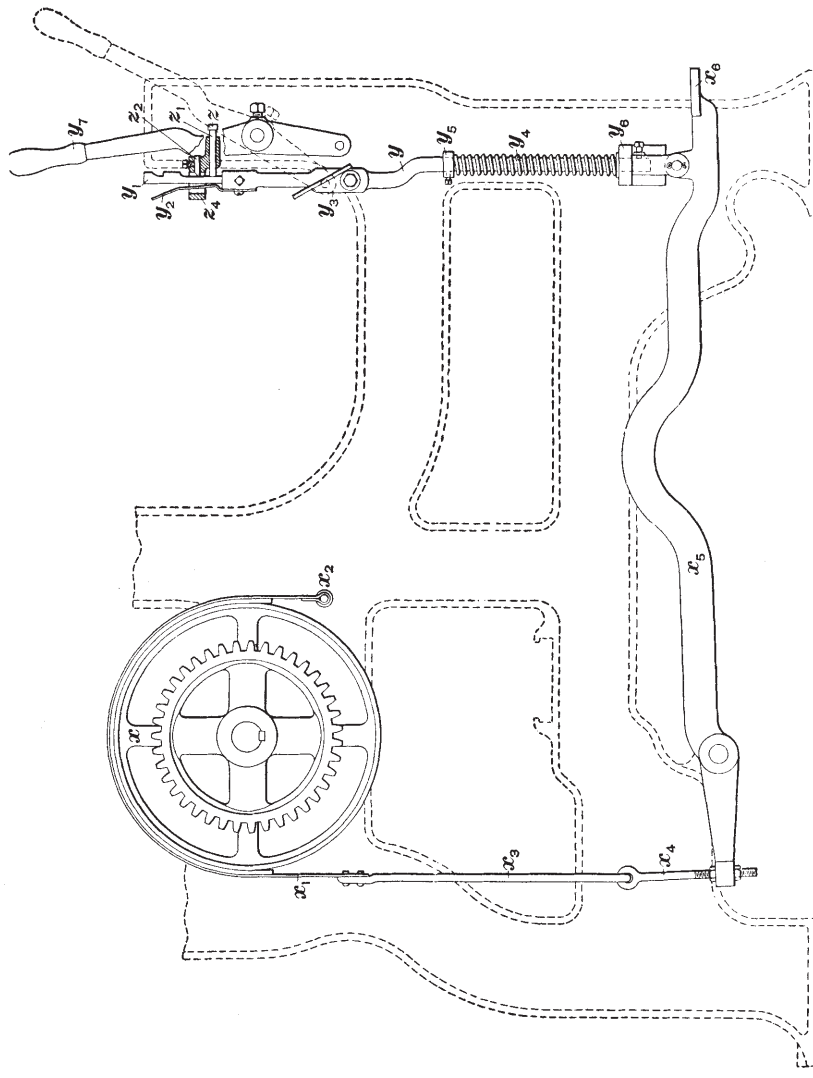

FIG. 21

collar  $y_6$ , rests against a casting  $y_6$  fastened to the frame of the loom and tends to keep the lever  $x_5$  in a raised position and the friction band  $x_1$  pressed firmly around the brake wheel. When the treadle  $x_6$  is pressed down, the spring  $y_4$  is compressed and the brake released, the whole arrangement being held in position by means of the notched locking

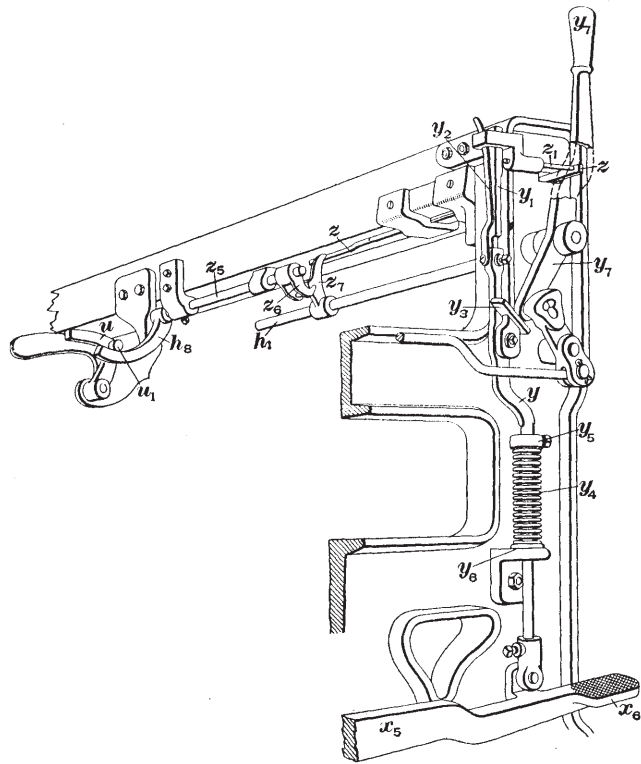

FIG. 22

piece  $y_1$ , which when drawn down is engaged by the adjustable steel projection  $z_2$ . A spring  $y_2$  that strikes the back of the casting  $z_4$  when the locking piece is lowered presses the latter forwards so that the jar of the loom will not allow it to become disengaged and the brake to be applied while the loom is running, but when the protector lever  $z$  is operated

by the protector motion or filling stop-motion, the plunger  $z$ , is forced forwards and disengages the locking piece  $y_1$  from the projection  $z_2$ , allowing the spring  $y_4$  to expand and lift the rod  $y$  with lever  $x_6$ , thereby tightening the friction band on the brake wheel and stopping the loom. By lowering the adjustable collar  $y_6$ , the compression of the spring  $y_4$  will be increased when the brake motion is locked; consequently, when it is released greater friction will be applied to the brake wheel  $x$  and the loom stopped correspondingly quicker. As the brake is applied and the rod  $y$  rises, a casting  $y_3$  bolted to it strikes the end of the shipper handle  $y_7$ , which is then in the position shown by the dotted lines, thus throwing off the power.

It will be noted that when this brake motion is used, the filling stop-motion is arranged somewhat differently, as shown in Fig. 22. In this case the lever  $h_8$ , instead of being attached to the shaft  $h_1$ , is fastened to a short independent shaft  $z_6$  and also, because it is brought nearer to  $u$ , is made curved instead of straight. A dog  $z_6$  is fastened to the other end of the shaft  $z_6$  and engages a lever  $z_7$  that is loose on the shaft  $h_1$  and engages with its free end the protector lever  $z$ . The result of this arrangement is that when the filling stop-motion is operated, the dog  $z_6$  will operate the lever  $z_7$ , which will in turn operate the protector lever  $z$  and put the brake on the loom. The same result will also occur if the protector motion is operated and its dagger strikes the protector lever  $z$ , but in either case the belt is not thrown off until the casting  $y_3$  strikes the end of the shipper handle  $y_7$ .

---

## SELVAGE MOTIONS

---

### CAM SELVAGE MOTIONS

**33.** There are several different types of **selvage motions** applied to fancy looms, the one shown in detail in Fig. 23 being a **cam-motion**. On the end of the upright shaft  $h$  is fastened a bevel gear  $h_6$  that drives another bevel gear  $h_{10}$ , imparting motion to a cam  $k$ . This cam works

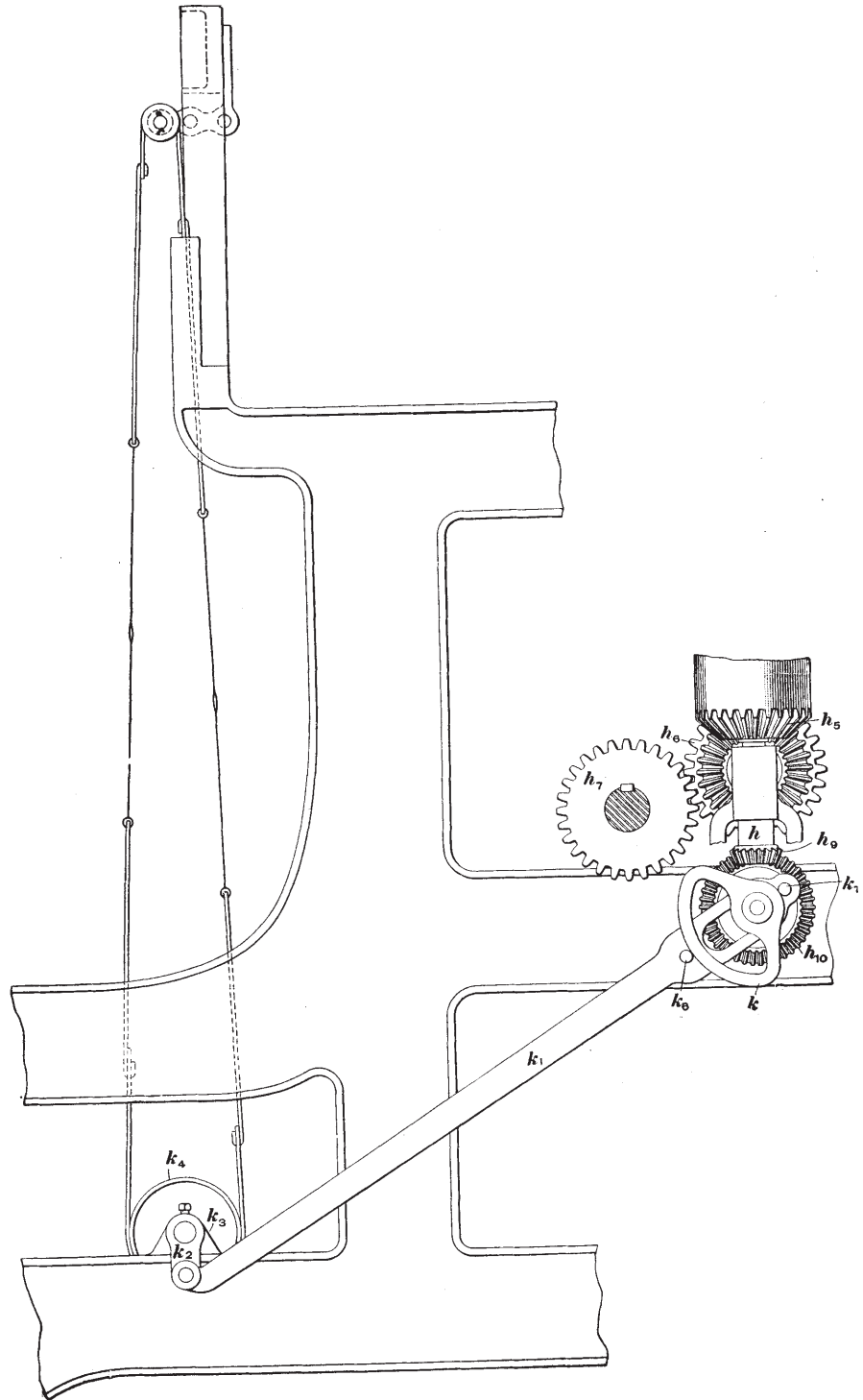

FIG. 23

between two pins  $k_6, k_7$  in the rod  $k_1$  and imparts to it a reciprocating motion that is transmitted by means of the arm  $k_2$  to the shaft  $k_3$ ; this shaft carries bosses  $k_4$  for operating the selvage heddles, which are connected to them by means of straps in the ordinary manner. The cam is so shaped that the selvage ends are alternately raised and lowered on every pick, so that a plain selvage is woven on each edge of the cloth.

UNIVERSAL SELVAGE MOTION

34. Fig. 24 is an illustration of a selvage motion by means of which the selvage ends may be operated in any

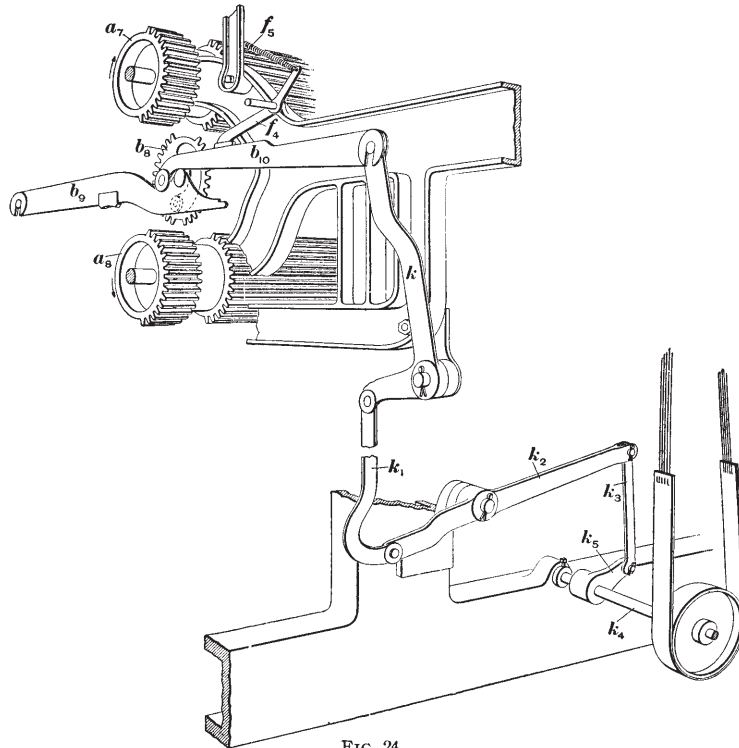

FIG. 24

desired manner, so that they may be made to change on every pick or may be made to remain stationary while two

or more picks are inserted in the selvage, thus weaving either plain or tape selvages on each edge of the cloth. In this motion the oscillating movement of the shaft  $k_4$  is obtained by means of an extra, or fifth, vibrator gear  $b_5$  placed between the box cylinder gears  $a_7$  and  $a_8$ , and operated by an extra row of risers or sinkers on the box chain. This vibrator gear is provided with a vibrator lever  $b_6$ , by means of which the risers and sinkers on the chain govern its movement, and a connector  $b_{10}$ , which transmits its motion to the elbow lever  $k$ . This lever is connected by means of a rod  $k_1$  to a lever  $k_2$ , which in turn is connected to an arm  $k_3$  on the shaft  $k_4$  by means of a rod  $k_3$ . The connector  $b_{10}$  is held in place by means of a follower lever  $f_4$ , which is constantly pressed on it by means of a spring  $f_5$ .

# WOOLEN AND WORSTED FANCY LOOMS

(PART 2)

Serial 487B

Edition 1

## CROMPTON FANCY LOOM

### INTRODUCTION

1. Although many arguments have been advanced and much has been said in favor of both open- and close-shed looms for weaving woollen and worsted fabrics, their relative value is undecided, for the reason that each loom has its disadvantages as well as its advantages. The typical close-shed loom, in which the warp yarn is all lowered to the level of the bottom shed after each pick, is rarely used in woollen and worsted weaving. Most of the looms employed in this class of work, if not of the open-shed type, operate on the split-shed principle, but the common practice is erroneously to call them close-shed looms. In regard to the relative merits of these two types, it may be safely stated that in the open-shed looms there is less strain on the warp yarn in opening the shed, since the harnesses are raised or lowered only when required by the weave, and no unnecessary movements are made. On the other hand, it is claimed that the so-called close-shed loom is easier on the warp yarn when the lay is beating up the filling, since when the reed delivers the blow to the fell of the cloth, all the warp yarn is level, or practically so, at the center of the shed and in a practically straight line from the whip roll to the breast beam. Thus

*For notice of copyright, see page immediately following the title page*



each warp thread sustains a portion of the blow and is in the best position to resist it. In the open-shed loom, the warp threads are deflected from a straight line by the harnesses, which keep the shed constantly open, so that they are not in a position to resist the blow of the lay as well as in the close-shed loom; moreover, in the open-shed loom, the blow must be resisted by a part of the warp, since some of the warp threads, being drawn through harnesses that are changing, are slack at this time and hence can support no part of the blow, whereas in the close-shed loom the entire warp is level at each pick, so that every warp thread helps to resist the blow of the lay.

Other things being equal, a close-shed loom is easier for the weaver than an open-shed loom, since, with this type of loom, the warp is brought level at each pick, thus enabling broken warp ends to be readily drawn in without resorting to any special leveling device for bringing the harnesses and warp level, as is necessary in looms of the open-shed class. With good strong warp yarns and well-made warps the close-shed loom will give the best of results, and is moreover a loom that is easily kept in repair; but it must be said that the tendency at the present time is to give the open-shed loom the preference. It has the advantage over the close-shed loom on fibrous and weak yarns, on account of the absence of all unnecessary chafing of the warp by the harnesses.

**2. The Crompton heavy-pattern fancy woolen and worsted loom** is shown in Figs. 1 and 2, the former being a front view and the latter a rear view. Although known as a close-shed loom, it actually forms a split shed, since the harnesses and warp yarn are brought level at the center of the shed after the insertion of each pick, whereas in the true close-shed, the warp is brought level with the line of the bottom shed. In addition to the difference in the principle of the shedding mechanism, this loom differs materially from other woolen and worsted looms in the principle and construction of its various other mechanisms; namely, the driving arrangement, the box motion, the filling stop-motion,

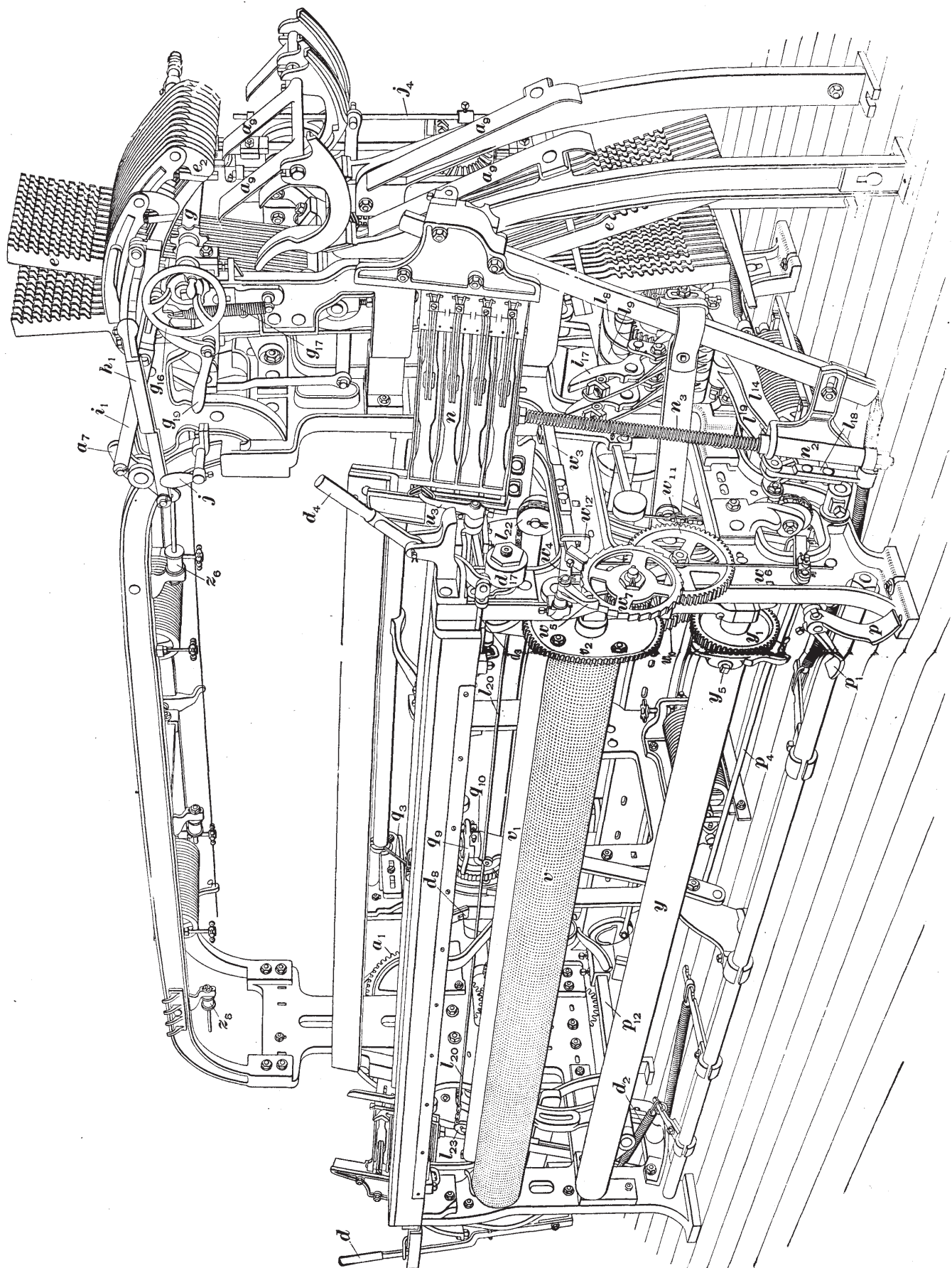

Double-page spread rotated 90° to fit on page.

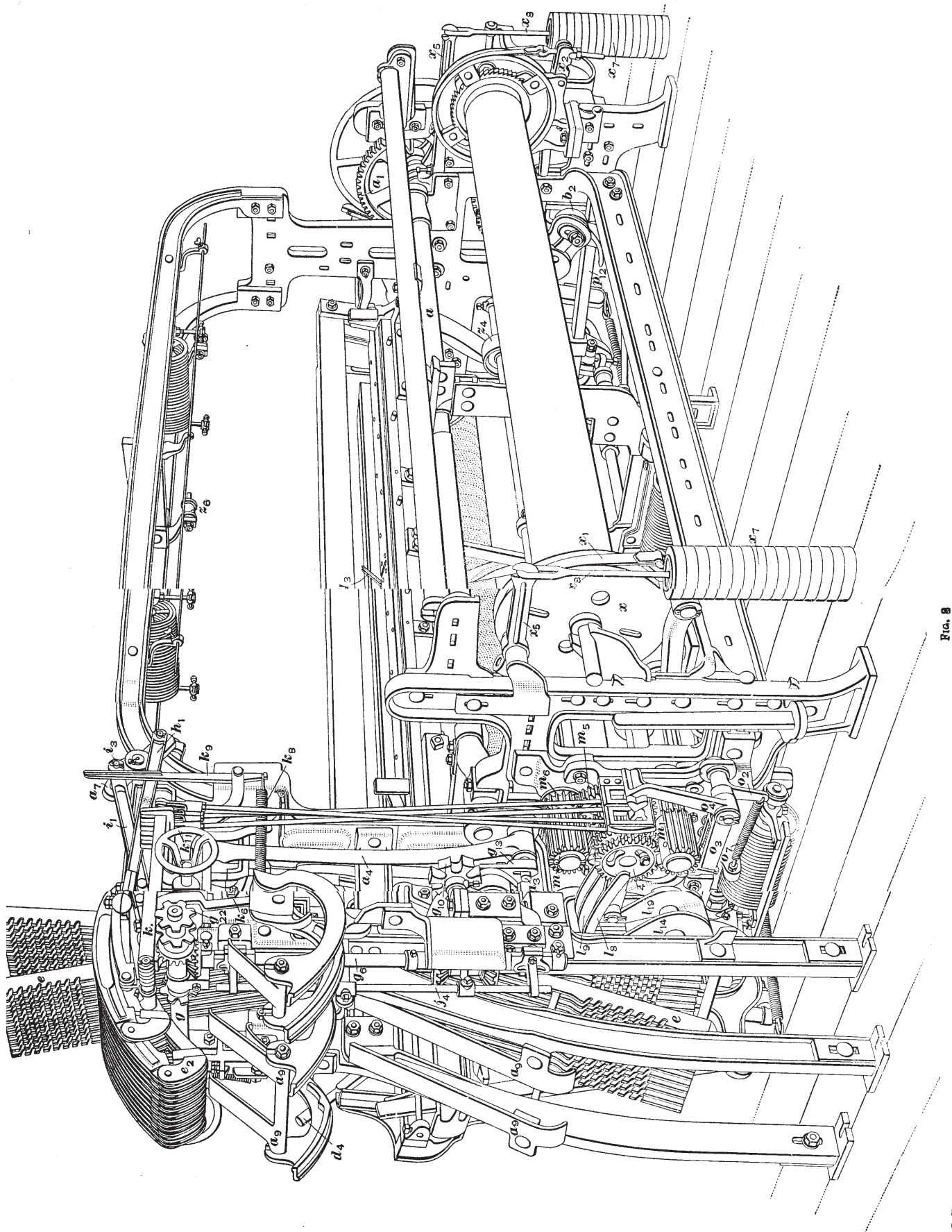

FIG. 8

Double-page spread rotated 90° to fit on page.

the protector motion, the take-up motion, and the selvage mechanism. The loom illustrated is not equipped with a brake motion. Other than these differences, the Crompton loom is of the usual construction.

---

### DRIVING

**3.** Motion is imparted to the loom by a driving belt running on a pulley  $c_1$ , Fig. 3 (*a*), fastened to the cross driving shaft  $c$ , which is supported in bearings attached to the frame of the loom and carries a leather-faced friction plate  $c_5$ . These parts are in motion continuously, but no motion is imparted to the loom unless the friction plate  $c_5$  is moved into contact with a friction plate  $c_2$  that is loose on the shaft  $c$ . Attached to the friction plate  $c_2$  and also loose on the shaft is a 19-tooth bevel pinion gear  $c_3$  that drives a 58-tooth gear  $b_1$ , fastened to the bottom shaft  $b$  of the loom. Motion is imparted to the crank-shaft  $a$  by a 58-tooth gear  $a_1$ , meshing with the gear  $b_1$ ; the crank-shaft and bottom shaft therefore revolve at the same rate of speed; in other words, the loom is equally geared.

The loom is started by throwing the friction plate  $c_5$  in contact with the plate  $c_2$ , which is accomplished by the shipper lever  $d$ . A collar  $c_8$  with two projecting lugs that extend into slots in the lever  $c_6$  is loosely supported on the shaft  $c$  and separated from the hub of the friction plate  $c_5$  by a leather washer  $c_{12}$ . An adjustable rod  $c_9$  attached to the upper end of the lever  $c_6$  connects it with one arm  $c_{10}$  of an elbow lever, the other arm  $c_{11}$  of which is cast in the form of a yoke and engages the shipper lever. As the shipper lever is drawn toward the center of the loom, against the tension of the spring  $d_2$ , attached to arm  $d_1$ , motion is imparted to the lever  $c_6$ , and the collar  $c_8$  that it operates forces the friction plate  $c_5$  in contact with  $c_2$ , allowing the motive power to be communicated to the loom. The leather washer  $c_{12}$  that is placed between the stationary collar  $c_8$  and the hub of the rotating friction plate  $c_5$  prevents wear, which would otherwise be excessive, since the pressure of the



collar on the friction plate must be of considerable intensity in order to cause the latter to drive the plate  $c_2$  and the loom. A similar leather washer  $c_4$  is placed between the sleeve of the pinion  $c_3$  and the bearing of the shaft  $c_1$ , to receive the thrust of the plate  $c_2$  when  $c_3$  is forced against it. In order to withdraw the friction plate  $c_3$  from the plate  $c_2$ , so as to stop the loom instantly when the shipper lever  $d$  is released and moved from the center of the loom by the spring  $d_2$ , a yoke casting  $c_7$  is bolted to the lever  $c_6$  and carries two projecting lugs engaging a groove in the hub of the plate. This yoke should be so adjusted that the lugs will not bear against the sides of the slot when the plate  $c_3$  is pressed in contact with the plate  $c_2$ , as this will quickly wear out the lugs; this whole pressure should be borne by the collar  $c_8$ .

The upper end of the shipper lever  $d$  extends through a slot  $d_5$ , Fig. 3 (*b*), and when drawn inwards toward the center of the loom is held in a recess, or notch  $d_6$ , Fig. 19. A shipper handle  $d_4$ , Fig. 3 (*b*), on the opposite side of the loom is connected with the lever  $d$  by a rod  $d_3$  located just below the breast beam, so that the loom may be started or stopped by either  $d$  or  $d_4$ , one of which is always easily within reach of the weaver. One point to be noted in connection with this driving arrangement is that as the gear  $c_3$  is loose on the shaft  $c_1$ , the lay may easily be pushed back by the weaver, as is frequently required when the loom is at rest and plates  $c_2$ ,  $c_3$  not in contact. The reason for this is that in so doing it is not necessary to turn back the shaft  $c_1$ , as in many similar driving mechanisms.

---

#### SHEDDING MECHANISM

4. The principle of the Crompton shedding mechanism is illustrated by the sectional view of the head-motion shown in Fig. 4. In this illustration, only one harness with its connections with the shedding mechanism is shown, but actually a number of harnesses are operated; in a standard loom, the equipment is 27 harnesses, any one of which may

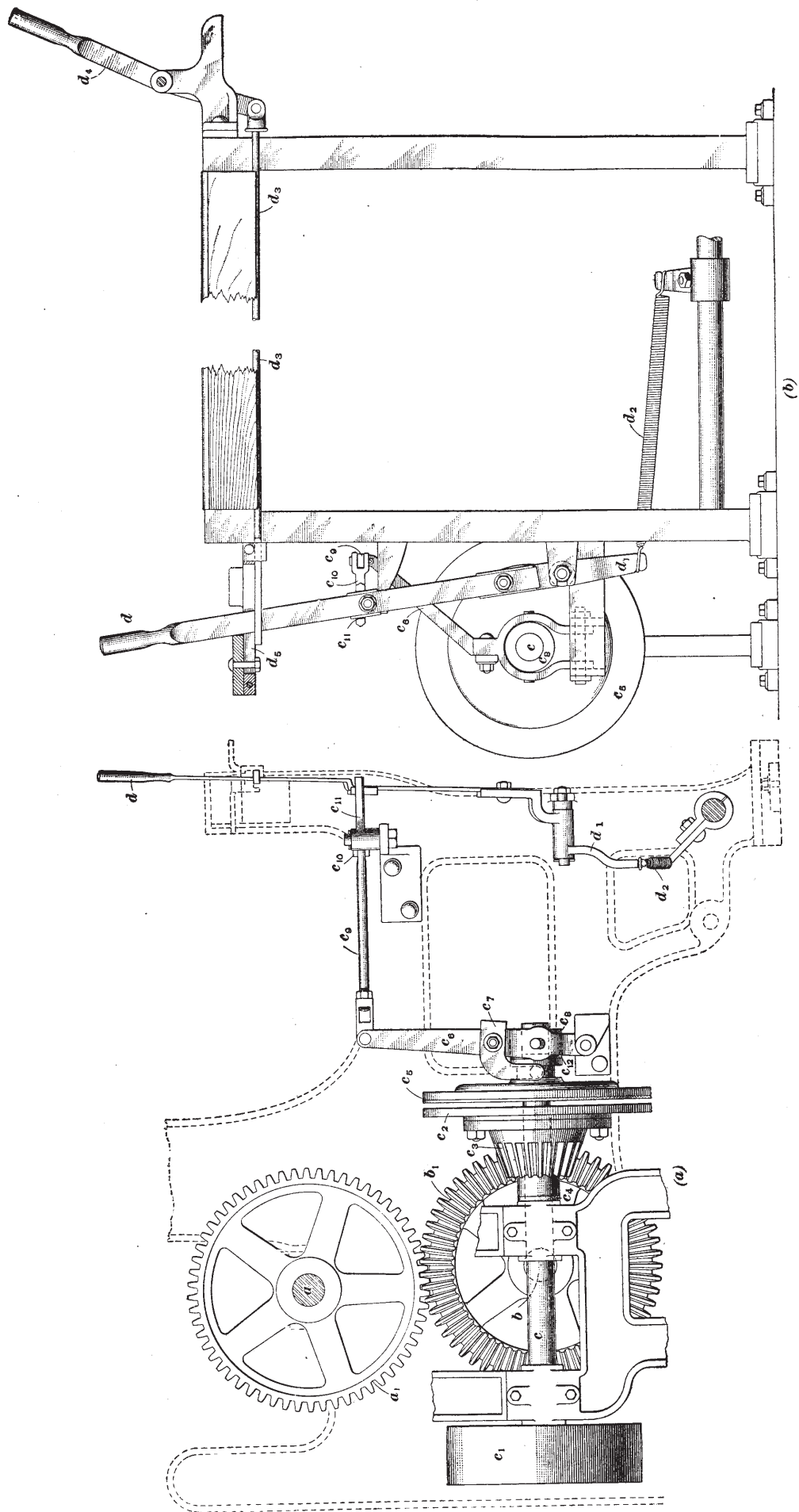
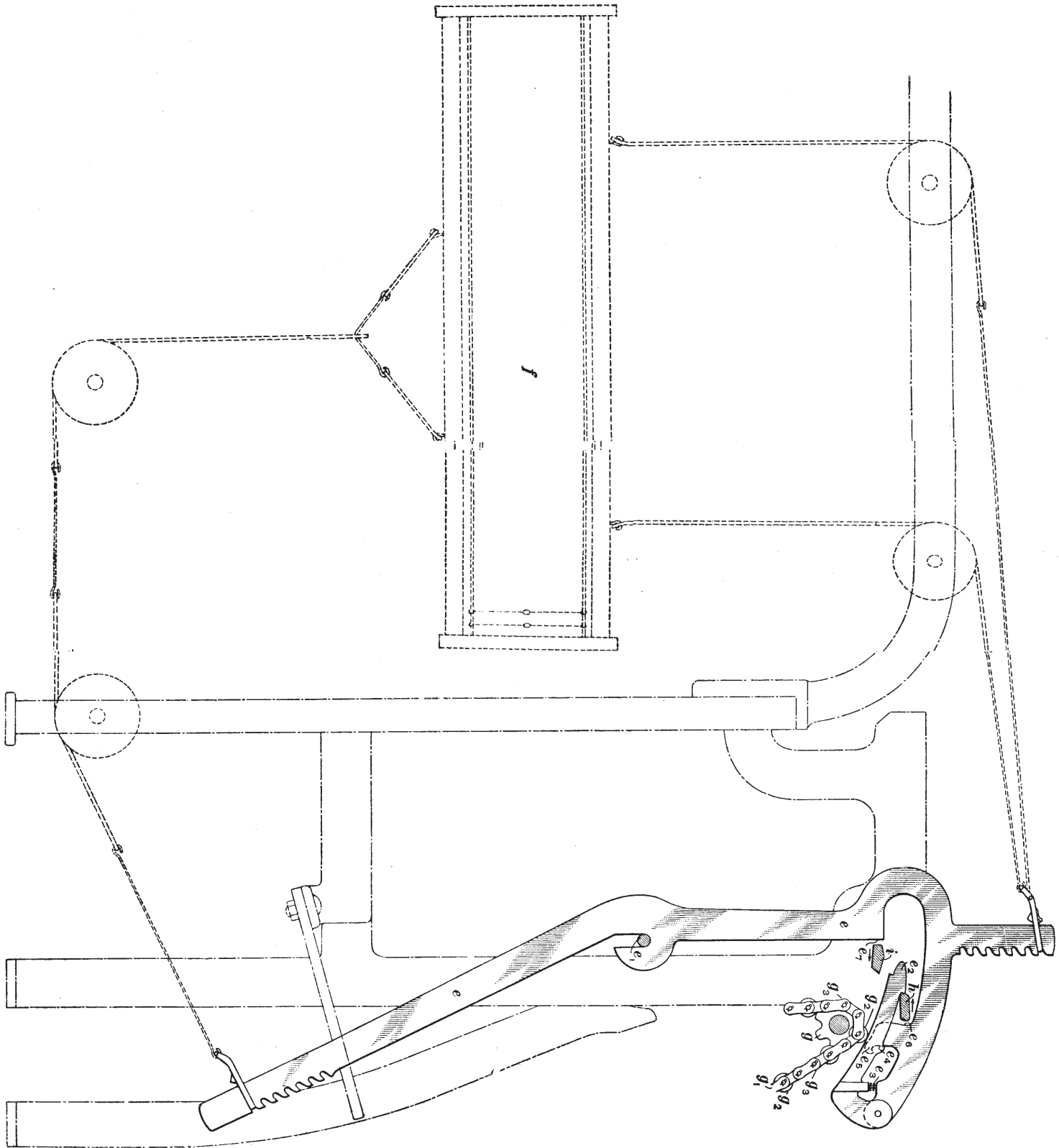

FIG. 3

Double-page spread rotated 90° to fit on page.

Fig. 4



Double-page spread rotated 90° to fit on page.



be raised or lowered entirely independent of the others. Each harness  $f$  is connected by straps, wires, and stirrups—the former running over suitable sheaves—to an angular harness lever, or jack,  $e$  supported on a rod  $e_1$ . A jack-hook  $e_2$  pivoted to the jack rests on the harness chain  $g_1$ , which is composed of rollers and washers threaded on suitable spindles or chain bars held together by flat links and secured by cotter pins. The harness chain is supported by a chain cylinder  $g$  having an intermittent rotary motion, so that a new bar of the harness chain will be forced under the jack-hooks at each pick of the loom. A roller  $g_2$  on the harness chain raises the jack-hook against the compression of a spring  $e_3$ , while a washer  $g_3$  on the harness chain allows the jack-hook to fall. The object of the spring  $e_3$  is to prevent vibration of the jack-hook and to insure its fall when a washer on the harness chain is brought into action.

The downward movement of the jack-hook is limited by a pin  $e_4$  on the jack-hook that rests in a hooked part  $e_5$  of the jack. To operate the jack so that it will raise and lower the harness, two sliding bars, or knives,  $i, h$  are employed; the former, since it raises the harness, is known as the **lifter**, and the latter, since it lowers the harness, is called the **depressor**. They slide in slots, shown in Figs. 6 and 10, in the framework of the machine and in opposite directions; that is, when the lifter  $i$ , Fig. 4, is moving from the loom, the depressor  $h$  is moving toward the loom, as shown by the arrows; and vice versa, when the lifter is moving toward the loom, the depressor is moving from it. When in the position shown in Fig. 4, both the lifter and depressor are just commencing to move in the direction of their respective arrows and all the harnesses are level in the center of the shed. In considering the action of this mechanism in raising and lowering the harnesses so as to produce the proper sheds for the insertion of the picks of filling, it is only necessary to deal with the method of operating 1 harness, since all the harnesses are operated in a similar manner.

With all the harnesses level in the center of the shed, the jacks all evenly in line, and the lifter and depressor in

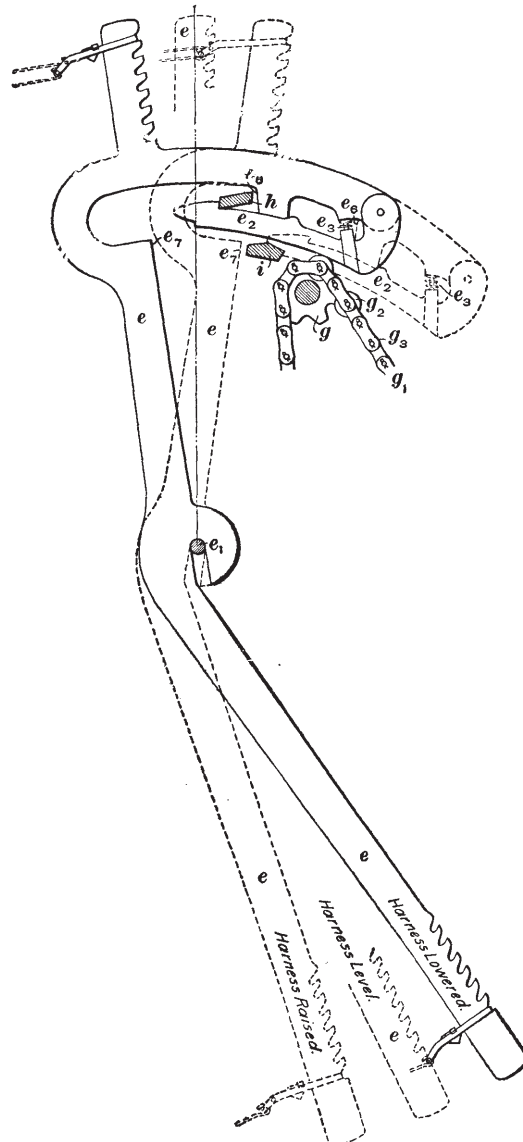

FIG. 5

the positions shown in Fig. 4, a new bar of the harness chain is forced under the jack-hooks, and if it contains a roller the jack-hook is raised, but if a washer, the jack-hook remains down and is kept there by the spring  $e$ . The jack-hook contains two hooks, or more properly notches, one on the upper edge, designed to be engaged by the depressor  $h$ , and another on its lower edge that may engage with the lifter  $i$ . Suppose that a roller  $g_2$  is forced under the jack-hook; then the latter will be raised, and as the depressor moves in the direction shown by the arrow in Fig. 4, it will engage the notch in the jack-hook, moving the top of the jack in toward the loom and the bottom part from the loom, as shown by the full lines in Fig. 5, thus lowering the harness. On the other hand, suppose that when a new bar of the harness chain is brought into action a washer is under the jack-hook; then it will remain in its lower position, and the lifter engaging the notch in its lower edge and moving in the direction shown by its arrow in Fig. 4, will move the top of the jack from the loom, and the bottom of the jack toward the loom, as shown by the dotted lines in Fig. 5, thus raising the harness. Certain harnesses being lowered and others raised by this operation will result in a shed being formed with the warp yarn, through which the shuttle is passed with the pick of filling. It should be particularly noted that a roller on the harness chain depresses the harness and a washer raises it; hence, in constructing harness chains for this loom, washers are threaded on the chain bars for risers in the chain draft and rollers for sinkers.

After the depressor  $h$  has moved in the direction shown by its arrow in Fig. 4 for a distance sufficient to lower the harness to the bottom shed, its motion is reversed. As this takes place, the front edge of the depressor frees the jack-hook, so that it will be ready to fall in case a sinker is brought under it when the next bar of the harness chain is brought around; but as the depressor continues to move, its back edge strikes the jack at the point  $e$ , and brings the jack back to its central position and the harness to the center of the shed. In the same way the motion of the lifter  $i$

is reversed, so that if a roller is to be forced under the jack-hook on the next pick it will be free to rise and engage the depressor. The continued motion of the lifter results in its back edge coming into contact with the jack at the point  $e_7$  and lowering it to its central position and the harness to the center of the shed. The jacks, harnesses, lifter, and depressor having now resumed their initial positions, a new bar of the harness chain is forced under the jack-hooks and the harnesses raised and lowered to produce the next shed for the insertion of another pick of filling.

Although this shedding mechanism is commonly and erroneously said to produce a close shed, it in reality makes a true split shed. The warp yarn is all level at the center of the shed after the insertion of each pick; then certain harnesses are raised and others lowered to form the shed, after which all the harnesses are brought level in the center again for a new selection of harnesses to be raised or lowered for the next shed.

**5. Driving.**—Motion is imparted to both the lifter and depressor and to the chain cylinder by suitable connections with the crank-shaft of the loom. The lifter and depressor have a sliding, or reciprocating, movement and are driven as shown in Fig. 6, which is a view of the Crompton shedding mechanism showing the driving parts only, the jacks and attached parts being removed. A casting  $a_2$  setscrewed to the crank-shaft  $a$  of the loom acts as a crank, and by means of a crankpin  $a_3$  imparts motion to an upright connecting-rod  $a_4$  that is adjustably connected to a casting  $a_5$  secured to a square shaft  $a_6$ . As the crank-shaft rotates, therefore, the connecting arm will rise and fall and impart a partial rotary reciprocating, or rocking, movement to the shaft  $a_6$ . Keyed to each end of this shaft is a casting  $a_7$  with two extended arms to which connecting-rods  $i_1, h_1$  are attached; the former is connected to one end of the lifter  $i$ , and the latter to one end of the depressor  $h$  with ball and socket joints  $i_2, h_2$ . The opposite ends of the lifter and depressor are connected to the square shaft  $a_6$  by similar arrangements; hence, as this

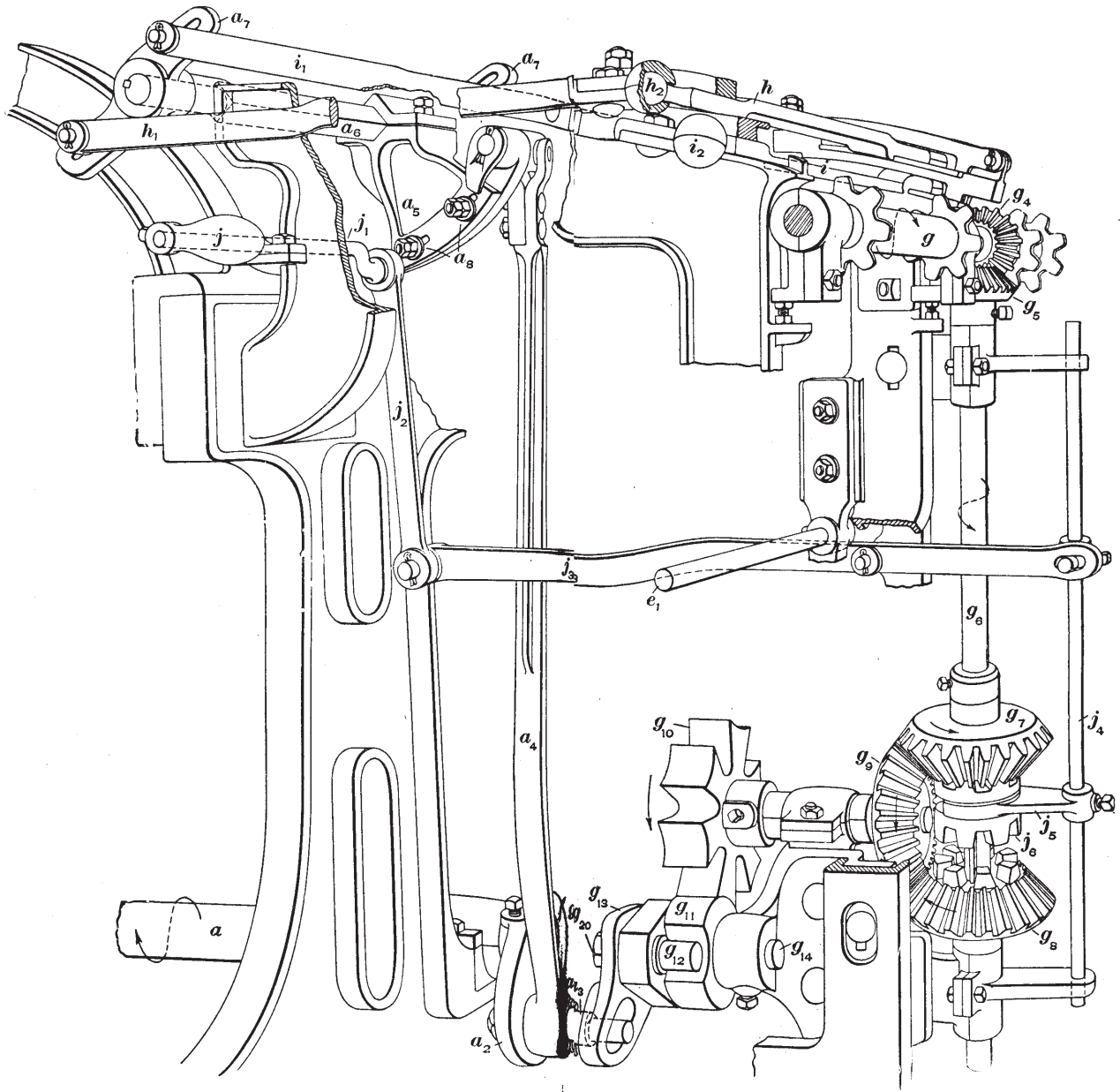

shaft rocks in its bearings, the requisite reciprocating sliding motion in opposite directions is imparted to them.

The chain cylinder  $g$  is also driven from the crank-shaft, but with an intermittent motion, so that a bar of the harness chain will be quickly brought into position beneath the jack-hooks and then come to a pause, in order to allow the lifter and depressor to engage the jack-hooks and raise or lower the harnesses. This characteristic movement of the chain cylinder is obtained as follows: An extension of the crankpin  $a_3$  engages with a slotted casting  $g_{13}$  loose upon a stud  $g_{14}$ . A pin gear  $g_{11}, g_{12}$  adjustably bolted to the casting  $g_{13}$  and also loose on the stud  $g_{14}$  engages with a 7-tooth star gear  $g_{10}$  (see also Fig. 7) fastened to a short shaft, to which is also attached a bevel gear  $g_9$  that meshes with another bevel gear  $g_7$ . This gear is loose on an upright shaft  $g_6$ , but imparts motion to the shaft through a sliding clutch collar  $j_6$  keyed to it. The clutch collar  $j_6$ , although it transmits the motion of the gear  $g_9$  to the shaft  $g_6$ , is capable of being slid along the shaft so as to impart motion to  $g_6$  through either gear  $g_7$  or  $g_8$ , as may be desired. On the upper end of the upright shaft is a bevel gear  $g_5$  meshing with a bevel gear  $g_4$  that is fastened to the shaft of the chain cylinder  $g$ . As the crankpin  $a_3$  rotates, the pin  $g_{12}$  engages one of the cut-outs in the star gear  $g_{10}$  and turns it the distance of 1 tooth, or one-seventh of a revolution; this motion communicated to the chain cylinder  $g$  turns the latter one-seventh of a revolution, since all the bevel gears used contain the same number of teeth. As the chain cylinder contains seven recesses for the reception of bars of the harness chain, this will result in a new bar of the chain being forced under the jack-hook at each revolution of the

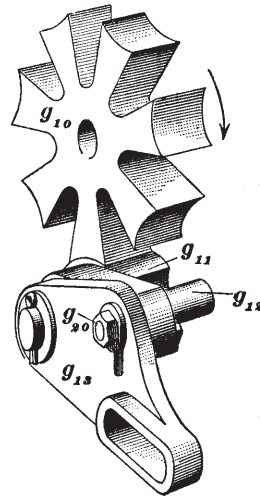

FIG. 7

pin gear  $g_{12}$ , or in other words, at each revolution of the crank-shaft  $a$ , or pick of the loom.

In order to hold the chain cylinder in its proper position while it is stationary, the end of each tooth of the star gear  $g_{10}$  is recessed so as to fit the curved concentric portion  $g_{11}$  of the pin gear; thus while this portion of the pin gear is in contact with the star gear it will impart no motion to it, but instead will hold it steady and prevent its turning.

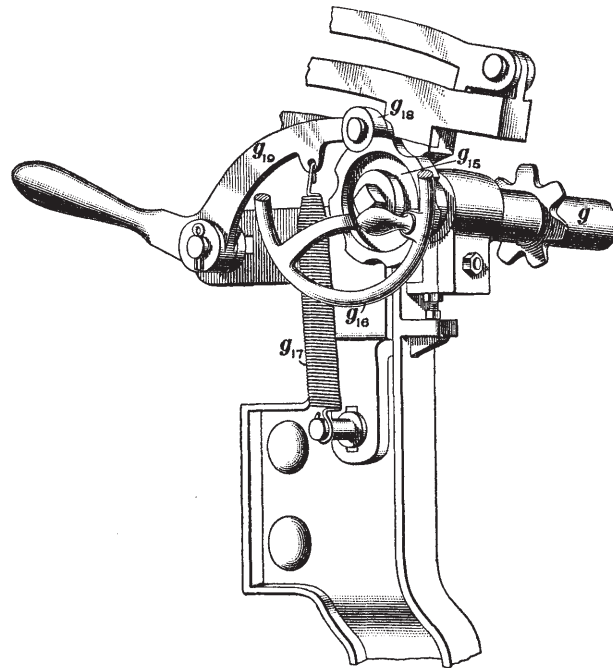

FIG. 8

To further steady the chain cylinder and hold it, while stationary, in its proper position, so that the bar of the harness chain will be presented to the jack-hooks in the correct position, a check-roll  $g_{18}$ , Fig. 8, is employed. This roll is carried by a lever  $g_{18}$ , to which is attached a spring  $g_{17}$  that keeps the roll firmly pressed against a disk  $g_{15}$  fastened to the shaft of the chain cylinder  $g$ . The roll, by engaging with cut-outs in this disk, holds the harness chain in the



proper position. A hand wheel  $g_{10}$  is also attached to the shaft of the chain cylinder for use when it is desired to turn the harness chain by hand. In order to support long and heavy harness chains so as to prevent their swinging and becoming caught in the mechanism of the loom, suitable guides  $a_6$ , Fig. 1, are bolted to the frame of the loom.

**6. Reverse Motion.**—During the ordinary running of the loom, motion is imparted to the upright shaft  $g_6$  in the direction of the arrow, by means of the gear  $g_7$  transmitting the power through the clutch collar  $j_6$ , which is engaged with the gear, as shown in Fig. 6. In this case, the chain cylinder  $g$  is driven in the direction shown by the arrow, and the harness chain runs under it, instead of over it as in the majority of looms. When, however, a mispick is made, or when for any cause a pick-out becomes necessary, the direction of rotation of the chain cylinder is reversed, so that the sheds will be

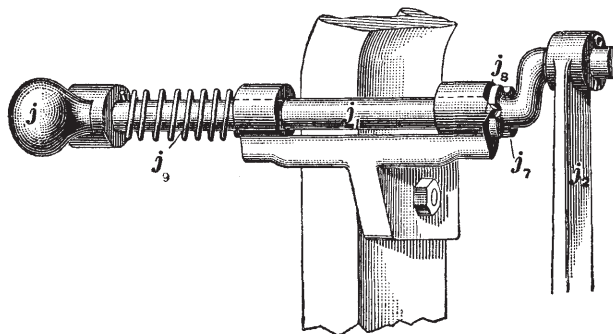

FIG. 9

opened in reverse order until the mispick is found or the pick-out completed. On the majority of looms this operation necessitates that the shedding mechanism be disconnected and turned over by the weaver, but on this loom it is accomplished by power, the loom running in the ordinary direction and the chain cylinder in the reverse direction.

This is accomplished as follows: A reverse handle  $j$ , Figs. 6 and 9, is setscrewed to the end of a short cross-shaft  $j_1$ , the other end of which is bent in the form of a crank and supports a rod  $j_2$  connected to a lever  $j_3$  operating

a sliding upright rod  $j_4$ . A yoke, or fork,  $j_5$  setscrewed to the rod  $j_4$  engages a slot in the clutch collar  $j_6$ , so that if the rod  $j_4$  is raised, the clutch will engage with the gear  $g_7$ , but if lowered, the clutch will engage with the gear  $g_8$ , which will then drive the upright shaft  $g_6$  and chain cylinder  $g$  in the opposite direction to that of the arrows on them, thus reversing the motion of the harness chain and opening the sheds in reverse order. If the handle  $j$  is in the position shown in Fig. 6, with the crank part of the shaft turned vertically downwards, the harness chain runs in the ordinary direction; but if thrown into the position shown in Fig. 9, with the crank turned vertically upwards, the harness chain moves in the reverse direction.

In order to prevent vibration of the loom from jarring the clutch collar  $j_6$  out of contact with either gear  $g_7$  or gear  $g_8$ , a series of notches  $j_7$  are made in a raised part of the shaft  $j_4$ ; these engage with a projection  $j_8$  on the frame, being pressed in contact with the latter by a coil spring  $j_9$ . This arrangement does not prevent the handle  $j$  from readily being operated, but simply acts as a stop to hold the mechanism in whatever position is desired. This reverse motion is an excellent arrangement and allows the weaver to reverse the sheds rapidly and with little exertion, it being simply necessary to turn the reverse handle and then operate the loom pick by pick with the power. When doing this the picking motion is disconnected, as will be explained later.

**7. Setting and Timing the Shedding Motion.**—The size of the shed is regulated by the amount of throw, or movement, given to the lifter and depressor, which may be adjusted by moving the connecting-rods  $i_1, h_1$ , Fig. 6, in the slots of the casting  $a_7$ . By moving them farther from the center of the square shaft  $a_6$ , more throw is given the lifter and depressor, which results in the harnesses being raised higher and depressed lower, and the size of the shed therefore increased; moving them in the opposite direction decreases the size of the shed. In adjusting the rods  $i_1, h_1$ , both at the front and back of the loom, care should be taken to

fasten them to  $a_7$ , equidistant from the center of the shaft  $a_6$ , so that the lifter and depressor will each have the same amount of movement and the harness be raised and lowered the same distance from the center of the shed. When the casting  $a_1$  is in such a position that the pin  $a_3$  is vertically over the center of the crank-shaft  $a$ , the connecting-rod  $a_4$  is raised to its highest position and the harnesses should be level in the center of the shed, with all the jacks even. If the harnesses and jacks are not in this position, they should be adjusted; this may be done by loosening the nuts  $a_8$ , so that the casting  $a_1$  may be moved until the jacks and harnesses are in the correct position, after which the nuts  $a_8$  are tightened.

In order to time the shedding motion, the lay is brought forwards until the reed is about 1 inch from the fell of the cloth. The casting  $a_1$ , Fig. 6, is then loosened and turned until it is vertically up, or until the jacks are all even, whereupon the casting is again tightened. This closes the shed, bringing the harnesses level when the lay is in the position in which it was placed at the start. If it is desired to have the loom shed later or earlier, the crank-shaft may be placed so that the reed is less than 1 inch from the fell of the cloth in the first case, or more than 1 inch distant in the second case.

In timing the harness-chain cylinder, it will be noted that the movement of the cylinder, which forces a new bar of the harness chain under the jack-hooks, must take place during the time that the lifter and depressor are returning the harnesses to the center of the shed, since the jack-hooks are then disengaged from the lifter and depressor and are therefore free to rise or fall, according to the selection of the new bar of the harness chain. To accomplish this, the pin gear  $g_{12}$  is set ahead of the crankpin  $a_3$ , Fig. 6, the amount of the advance being adjusted by loosening the nut  $g_{20}$ , Fig. 7, and moving the pin gear forwards to the desired position. When the pin  $a_3$ , Fig. 6, is vertically above the center of the crank-shaft, the pin gear  $g_{12}$  should have completed the movement of the star gear  $g_{10}$  and be well disengaged from it, so that the concentric part  $g_{11}$  of the pin gear will be engaged with the hollow ends of the teeth of the star gear.

## BOX MOTION

8. As in most fancy woolen and worsted looms, the Crompton box motion is arranged to operate four boxes on each end of the lay, any one of which may be raised so as to be level with the race plate when required. The raising and lowering of the boxes is controlled by a box chain  $g_{21}$ , Fig. 10, that is similar to the pattern, or harness, chain, except that it is only wide enough to contain four rollers, or washers, for operating four fingers  $k, k_1, k_2, k_3$ . Two of these fingers  $k, k_1$

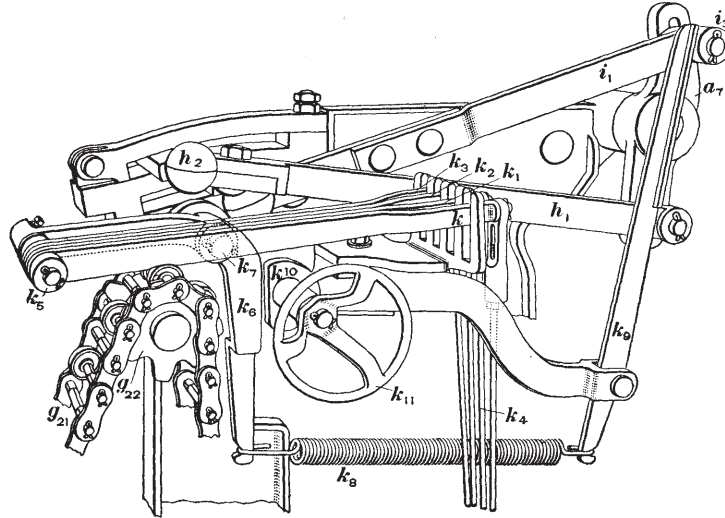

FIG. 10

control the operation of the boxes on the right of the loom, while the other two  $k_2, k_3$  control the boxes on the left of the loom. The box-chain cylinder  $g_{22}$  is fastened to the same shaft as the harness-chain cylinder  $g$ , Fig. 6; consequently, the box chain must move in unison with the harness chain, and as it is therefore impossible for the box chain to get out of time with the harness chain, the correct box must always be brought level with the race plate, and the correct color of filling placed in each shed. The fingers  $k, k_1, k_2, k_3$ , Fig. 10,

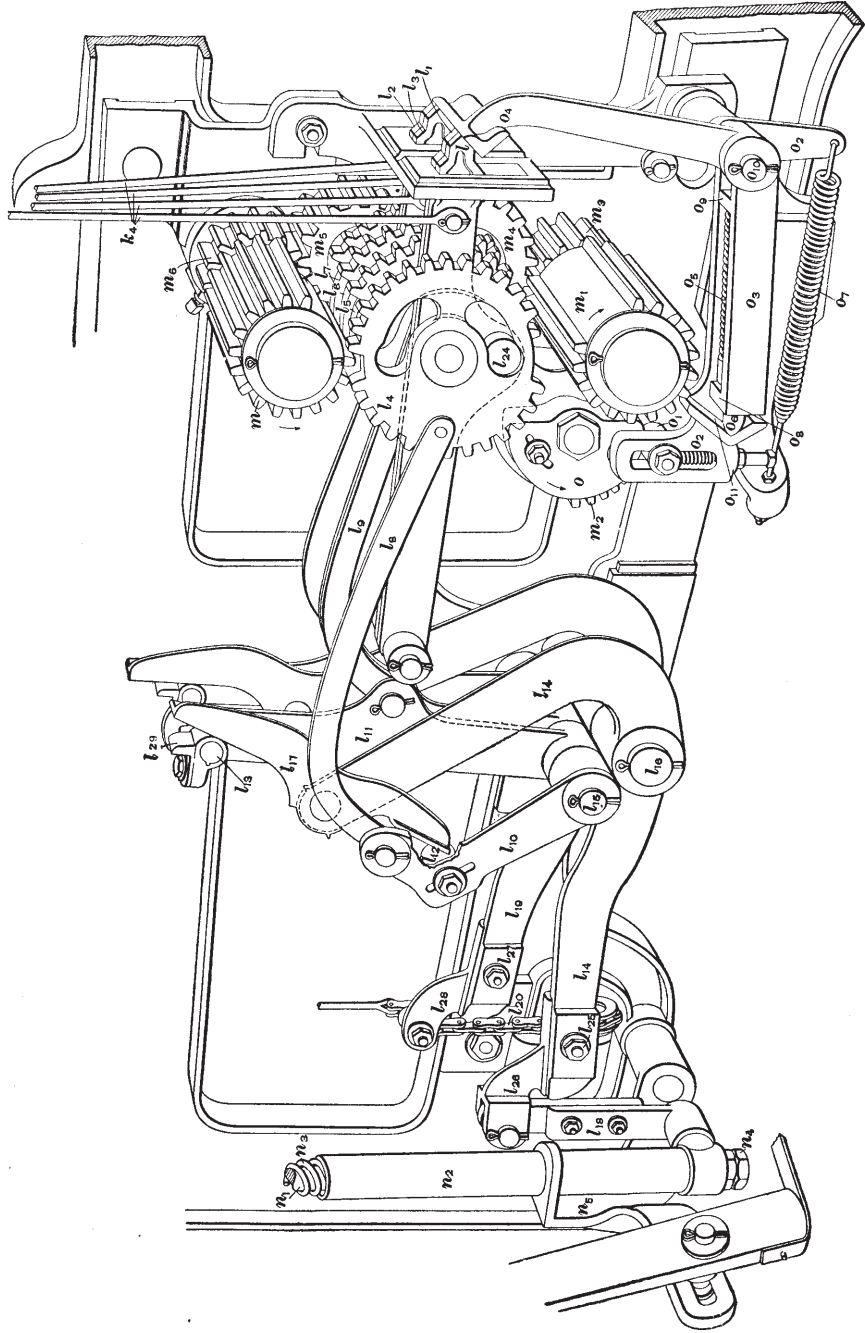

FIG. 11

are connected, by means of four adjustable rods  $k_4$ , with four vibrator levers  $l, l_1, l_2, l_3$ , Fig. 11;  $k$  is connected with the vibrator lever  $l$ ;  $k_1$ , with the vibrator lever  $l_1$ ;  $k_2$ , with  $l_2$ ; and  $k_3$ , with  $l_3$ . By means of these connections, if a roller is placed on the box chain so as to come under any particular finger, the vibrator lever connected to that finger will be raised, while if a washer on the box chain comes under the finger, the vibrator lever will be lowered.

Each of the vibrator levers  $l, l_1, l_2, l_3$  carries a vibrator gear  $l_4, l_5, l_6, l_7$ , respectively. Thus, if any vibrator lever is raised, the vibrator gear attached to it will be brought in contact with a cylinder gear  $m$ , while if the lever is lowered, the vibrator gear will come in contact with the cylinder gear  $m_1$ ; these are sometimes known as *quill gears*, because the teeth are placed on a cylindrical sleeve, or quill. Each of the vibrator gears has 26 teeth, divided into two sections separated by spaces equal to those occupied by 1 tooth and 4 teeth, respectively. Each cylinder gear has 15 teeth separated by a small blank space.

Since motion is imparted to the cylinder gears, it will also be imparted to the vibrator gears when they are raised or lowered so as to be in contact with them. A steadying pin  $l_8$ , attached to each vibrator lever works in a slot in the vibrator gear attached to that lever and governs the extent of the movement of the gear when operated on by either cylinder gear. Vibrator gears  $l_4, l_5$  operate the boxes on the right-hand side of the loom, and since vibrator gears  $l_6, l_7$ , which operate the boxes on the left-hand side of the loom, are arranged in a similar manner and operate in the same way, the former only will be dealt with in the following description.

Attached to the vibrator gear  $l_4$  is a connecting-rod  $l_9$ , and to the vibrator gear  $l_5$  a similar rod  $l_{10}$ . Connecting-rod  $l_9$  is also attached to a lever  $l_{11}$ , and connecting-rod  $l_{10}$  to a lever  $l_{12}$ , both of which are fulcrumed on a stud  $l_{13}$ . An elbow lever  $l_{14}$  fulcrumed on the stud  $l_{13}$  carries a double-ended lever  $l_{17}$  at its upper extremity, while its other end is connected to the boxes on the right-hand side of the loom by means of the

castings  $l_{26}$ ,  $l_{18}$ , sleeve  $n_2$ , spring  $n_3$ , and box rod  $n_1$ , the boxes being carried on the upper end of the latter. The weight of the boxes operating through the lever  $l_{14}$  keeps the lever  $l_{17}$  constantly in contact with a stud  $l_{13}$  on the lever  $l_{11}$  and a roller  $l_{12}$  fastened to the lever  $l_{10}$ .

**9.** The manner in which this arrangement raises and lowers the boxes is as follows: If a roller is placed on the box chain so as to raise the finger  $k$ , Fig. 10, the vibrator lever  $l$ , Fig. 11, will also be raised; this will raise the vibrator gear  $l_4$ , so that it will engage with the cylinder gear  $m$ . The cylinder gear will then turn the vibrator gear one-half of a revolution, or until the blank space equal to 4 teeth comes on top; this will result in throwing the connection of the rod  $l_6$  to the other side of the vibrator gear, which will draw in the rod and pull the lever  $l_{10}$  to the right. As this takes place, the roller  $l_{12}$  will force the lower end of the double-ended lever  $l_{17}$ , the other end of which is resting on  $l_{13}$ , also toward the vibrator gear, which will result in the upper end of the lever  $l_{14}$  being operated in the same direction and its other end raised. Since this end of the lever is connected to the box rod and boxes, the latter will also be raised.

In a similar manner, if the roller is placed under the finger  $k_1$ , Fig. 10, the vibrator lever  $l_1$ , Fig. 11, will be lifted and the vibrator gear  $l_5$  raised in contact with the cylinder gear  $m$ . Motion being imparted to this vibrator gear, it draws the connecting-rod  $l_6$  and lever  $l_{11}$  to the right, the stud  $l_{13}$  on the latter operating the upper end of the double lever  $l_{17}$ , which since its opposite end is resting against the roller  $l_{12}$ , will operate the lever  $l_{14}$  and also raise the boxes. This connection, however, gives the boxes a lift equal to the distance of two boxes, while the former connection gave a lift of but one box; that is, the vibrator gear  $l_4$  and its connections will raise the boxes from the first to the second box, while the vibrator gear  $l_5$  and its connections will raise the boxes from the first to the third box. Both vibrator gears, if operated, will raise the boxes from the first to the fourth box. Reversing the operations described, that is, lowering



the vibrator gears so that they will engage the cylinder gear  $m_1$ , reverses the operation of the levers and lowers the boxes. From this it will be seen that any box can be brought level with the race plate by placing the proper roller or riser on the box chain so that the shuttle that it contains will be driven across the loom.

Vibrator gears  $l_6, l_7$  are connected to the boxes that they govern in the same way as the vibrator gears  $l_4, l_5$ , but the

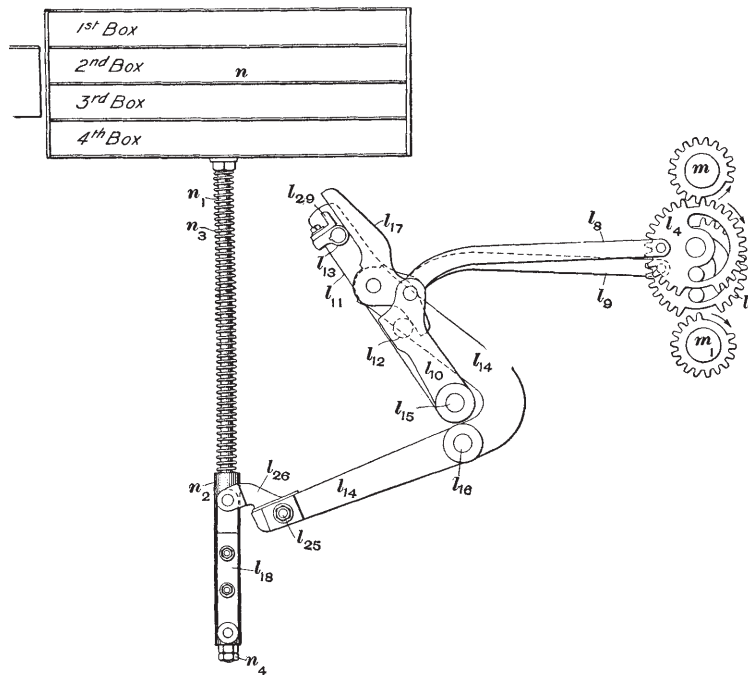

FIG. 12

casting  $l_{2r}$  on the end of lever  $l_{10}$  instead of being connected directly to the lifting rod is connected to a chain  $l_{20}$  that, as will be explained later, is connected to the boxes on the opposite, or left-hand, end of the lay.

**10.** In order to make the system of levers operating the boxes more clear, Figs. 12, 13, 14, and 15 are given. These are diagrammatic views showing the positions of the boxes

when the box levers are in their four possible positions. Fig. 12 shows the first box level with the race plate. In this case, the levers  $l_{10}$ ,  $l_{11}$ ,  $l_{14}$ ,  $l_{17}$  are in the position shown, both connecting-rods  $l_8$ ,  $l_9$  being extended to the left by the vibrator gears  $l_4$ ,  $l_5$ . In this figure, the vibrator gear  $l_4$  is shown raised and just commencing to be turned by the cylinder gear  $m$  to raise the second box so that it will be level with the race plate.

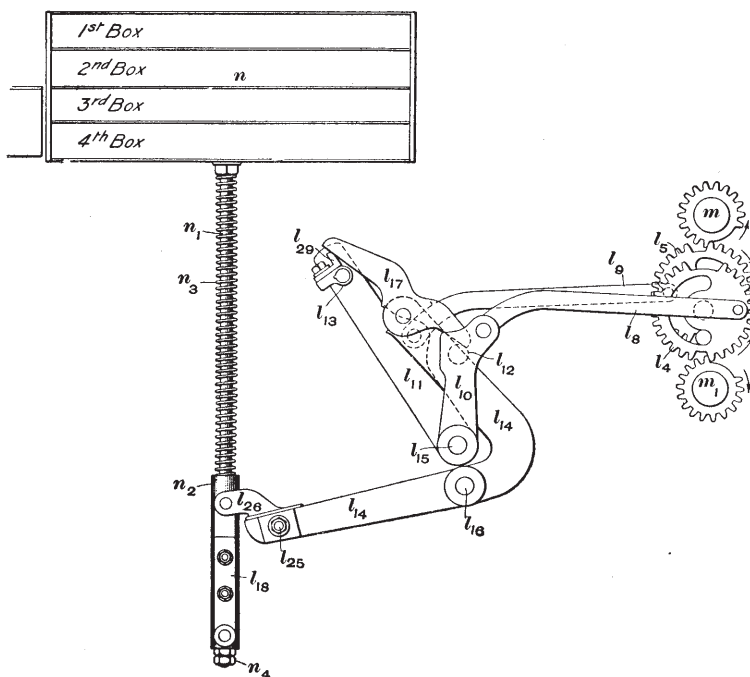

FIG. 13

Fig. 13 shows the second box raised level with the race plate, the lever  $l_{11}$  having remained stationary, but the lever  $l_{10}$  having been drawn in and having imparted a sufficient motion to the levers  $l_{17}$ ,  $l_{14}$  to raise the boxes the distance of one box. In this figure, the vibrator gears  $l_4$ ,  $l_5$  are shown in the position they will assume just before the third box is to be brought level with the race plate. In this case, the vibrator

gear  $l_6$  is raised so as to engage with the cylinder gear  $m$  and operate the lever  $l_{11}$ , while the vibrator gear  $l_4$  is shown lowered so as to engage with the cylinder gear  $m_1$ , in order to return the lever  $l_{10}$  to its original position.

Fig. 14 shows the boxes raised so that the third box is level with the race plate, lever  $l_{10}$  having been returned to its original position and lever  $l_{11}$  having been operated so as to

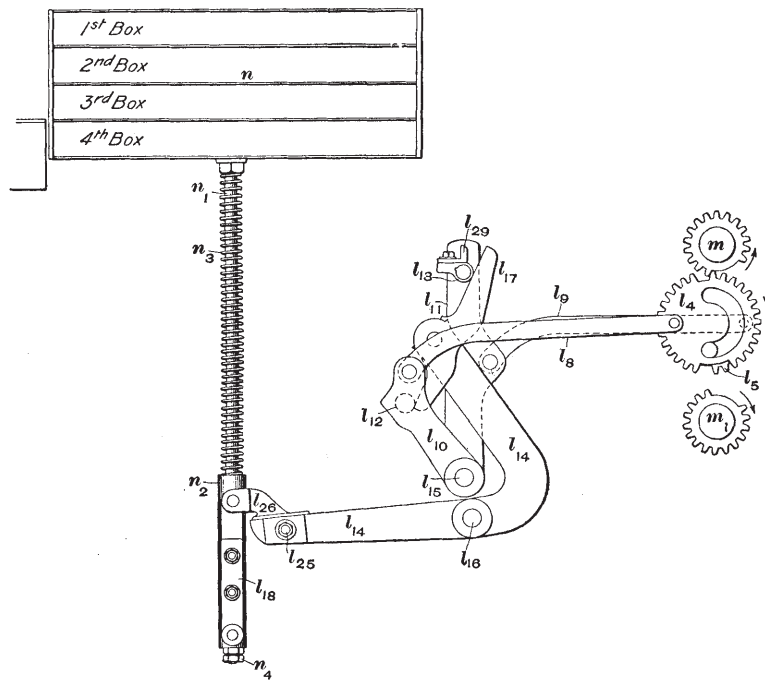

FIG. 14

give the boxes their requisite lift of the distance of two boxes. In this figure, the vibrator gears  $l_4, l_5$  are shown in the position they will assume just before the fourth box is brought level with the race plate; that is, both vibrator gears must be operated on by the top cylinder gear  $m$ . In this case, the vibrator gear  $l_5$  has already been operated on and vibrator gear  $l_4$  is just about to be operated on by the top cylinder gear.

Fig. 15 shows the position of the boxes with the fourth box level with the race plate. In this case both the levers  $l_{10}, l_{11}$  are operated, raising the lever  $l_{14}$  to its greatest extent and bringing the fourth box level with the race plate. The vibrator gears  $l_4, l_5$  are shown in the position that they will assume just before the boxes are returned with the first box level with the race plate. In this case both vibrator

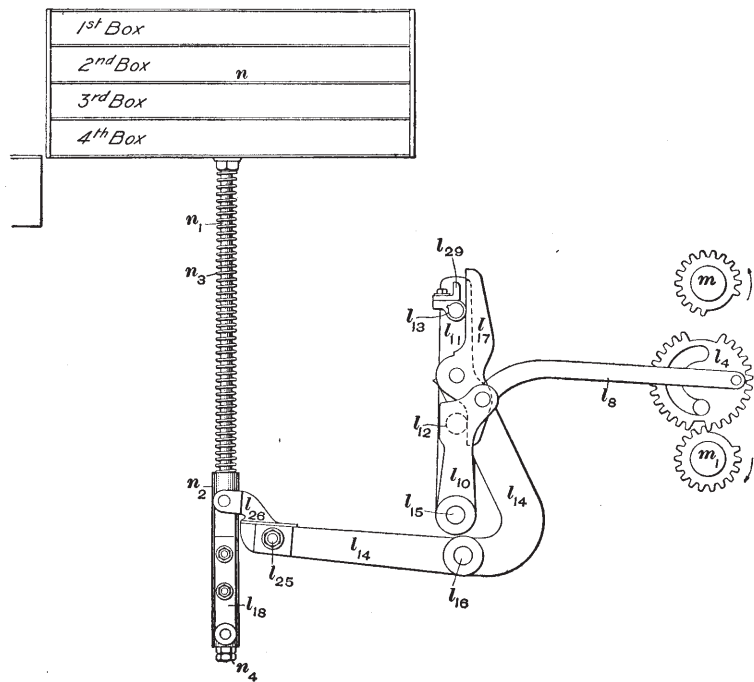

FIG. 15

gears will have to be brought in contact with the cylinder gear  $m_1$ , so as to lower the levers  $l_{10}, l_{11}$  to their initial positions, as shown in Fig. 12.

By properly threading rollers or washers on the box chain, so as to raise or lower fingers  $k, k_1$ , the boxes may be raised as desired. For instance, if two washers are placed on the box chain so as to come under these fingers, the lever  $l_{14}$  will assume the position shown in Fig. 12 and the first box on the

right-hand side of the loom will be level with the race plate. If a washer is placed under the finger  $k$ , and a roller in position to operate the finger  $k$ , the lever  $l_{14}$  will assume the position shown in Fig. 13, the second box in this case being level with the race plate; but if the roller operates the finger  $k$ , and the washer comes under the finger  $k$ , the lever  $l_{14}$  will assume the position shown in Fig. 14 and the third box will be level with the race plate. If two rollers are used and both fingers  $k$ ,  $k_1$  raised, the lever  $l_{14}$  will assume the position shown in Fig. 15 and the fourth box will be raised. This it will be understood operates only those boxes on the right-hand side of the loom, but by placing rollers or washers on the box chain so as to operate the fingers  $k_3$ ,  $k_2$ , Fig. 10, the boxes on the left-hand side of the loom may be operated in a similar manner.

**11.** Fig. 16 is a front view of the boxes on each end of the lay, and shows the method of connecting them with the castings  $l_{26}$ ,  $l_{28}$  on the ends of the box levers  $l_{14}$ ,  $l_{19}$ , Fig. 11. The boxes  $n$  are fastened to the box rods  $n_1$ , on which are placed strong spiral springs  $n_3$  that firmly press the sleeves  $n_2$  against the nuts  $n_4$  screwed to the ends of the box rods. The sleeves  $n_2$  are free to slide through the castings  $n_5$  when operated by the box motion. The lever  $l_{14}$  operates the boxes on the right-hand side of the loom by being directly connected to the sleeve  $n_2$  by the castings  $l_{26}$ ,  $l_{18}$ , but the casting  $l_{28}$  on the lever  $l_{19}$  that operates the boxes on the left-hand side of the loom is connected to the sleeve  $n_2$  on the left-hand side by means of chains and rods  $l_{20}$ , the former running around sheaves  $l_{21}$ ,  $l_{22}$ ,  $l_{23}$ . In raising the boxes, it will be seen that since motion is imparted to the sleeves  $n_2$ , and not to the box rods  $n_1$ , the motion of the boxes is dependent on the springs  $n_3$ , and if the picker or a shuttle is caught in the boxes, the spring will be compressed and no damage or broken parts will result. The boxes drop by their own weight when released by the box motion, which is therefore only a semipositive motion.

**12. Driving.**—The motion of the boxes on a box loom is intermittent, since it is necessary that they should be at

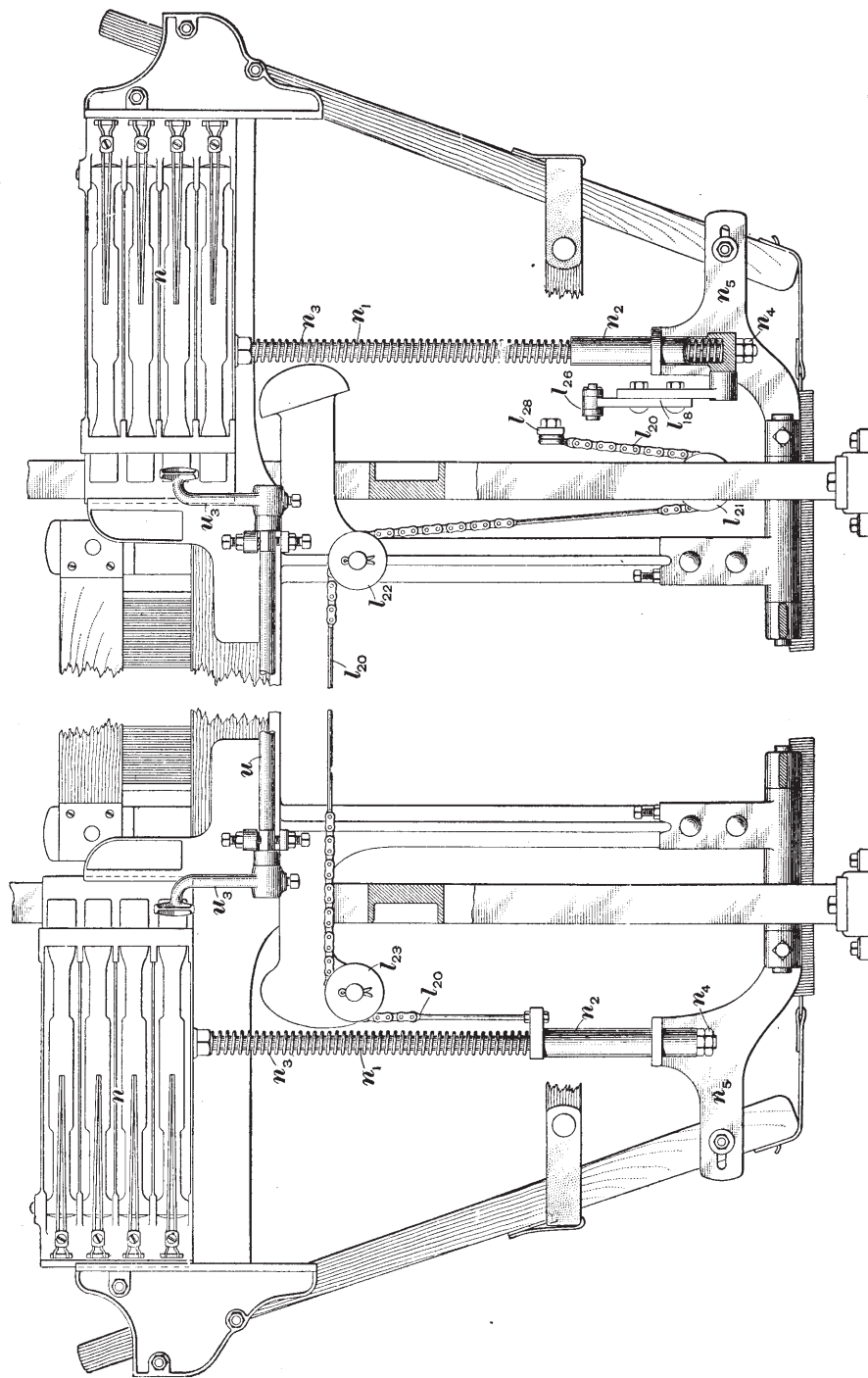

FIG. 16

rest while the loom is picking and until the shuttle is well boxed on the opposite side of the loom; hence, the motion of the cylinder gears  $m, m_1$ , must also be intermittent, so as to quickly change the boxes after the shuttle comes to rest, having them completely changed before the next pick of the loom. This intermittent motion of the cylinder gears is obtained in the following manner: Attached to the end of the bottom shaft of the loom is a segment gear  $m_2$ , Fig. 17, one-half of its circumference containing 14 teeth,

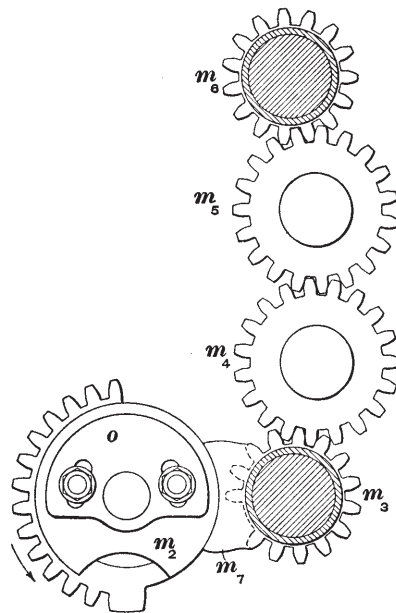

FIG. 17

one of which is a double tooth, while the other half is smooth. Attached to the bottom cylinder gear is a gear  $m_3$ , containing 14 teeth and a blank space into which the double tooth on the gear  $m_2$  meshes. As the gear  $m_2$  is rotated by the bottom shaft in the direction of the arrow,  $m_3$  will remain stationary until the double tooth on  $m_2$  comes around and engages it, whereupon it will be turned exactly one revolution, since  $m_3$  and  $m_2$  each contain 14 teeth; the cylinder gear will therefore make one revolution to each

revolution of the bottom shaft, or in this case, as the crank-shaft and bottom shaft are equally geared, one revolution to each pick of the loom. During the time that the teeth of the gear  $m_2$  are not in contact with the teeth of  $m_3$ , the cylinder gears are held stationary by a piece  $m_7$ , the end of which is recessed to fit the smooth concentric portion of  $m_2$ , thus making it impossible for  $m_3$  to move. When the double tooth of gear  $m_2$  begins to mesh with the blank space or



gear  $m_3$ , one corner of the piece  $m_7$ , will move into the recess seen on gear  $m_2$  and thus permit  $m_3$  to rotate. The motion of the bottom cylinder gear is transmitted to a gear  $m_6$  that is fastened to the top cylinder gear through two intermediate gears  $m_4, m_5$ ; thus motion is imparted to both cylinder gears at the same time, but in opposite directions.

**13. Lock-Knife.**—During the time that the cylinder gears  $m, m_1$  are imparting motion to the vibrator gears  $l_4, l_5, l_6, l_7$ , Fig. 11, the vibrator levers  $l, l_1, l_2, l_3$  must be held securely in position, so that those vibrator gears that are down will be held securely meshed with the bottom cylinder gear  $m_1$ , and those that are raised, with the top cylinder gear  $m$ . This is accomplished by means of a lock-knife  $o_4$ , which is operated by a cam  $o$  bolted to the driving gear  $m_2$  in such a manner that it engages the ends of the vibrator levers at the proper time and holds them in position. A casting  $o_2$  loose on the stud  $o_{10}$  has an extended arm to which a spring  $o_7$  is attached, and also carries a roller  $o_1$  adjustably fixed in a vertical slot; the roller is operated on by the cam  $o$  which, as it revolves, alternately presses down the roller against the tension of the spring  $o_7$ , and allows the tension of the spring to raise the roller. The motion of the roller is, of course, imparted to the casting  $o_2$  and also to the lock-knife  $o_4$ , although the latter is not directly connected to  $o_2$ , the arrangement being as follows: The lock-knife  $o_4$  and the casting  $o_3$  are cast in one piece that is loose on the stud  $o_{10}$ . Holes are bored through two extended lugs  $o_8, o_9$  on the casting  $o_3$ , and these guide a plunger  $o_6$ , which is pressed by a strong spring  $o_5$  into a recess  $o_{11}$  cast in the casting  $o_2$ . By this means the castings  $o_2, o_3$  act as one piece, and the motion of the cam  $o$  is readily transmitted to the lock-knife  $o_4$ ; but still should the lock-knife strike against the ends of the vibrator levers in such a manner as to be prevented from moving in far enough, no breakage of parts will occur, since in this case the plunger  $o_6$  is forced out of the recess  $o_{11}$ , allowing the casting  $o_2$  to be forced down by the cam without imparting any additional motion to the lock-knife.

**14. Relief Motion.**—The timing of the lock-knife and of the chain barrel  $g_{22}$ , Fig. 10, is such that when a new bar of the box chain is forced under the fingers  $k, k_1, k_2, k_3$  the lock-knife is engaged with the ends of the vibrator levers. It will be seen, therefore, that if there were not some relief motion provided, some part of the fingers or their connections with the vibrator levers would be broken, since it is obviously impossible to raise any one of the fingers if the vibrator lever to which it is connected were held down by the lock knife. To provide for this difference in the timing of these parts, the fingers  $k, k_1, k_2, k_3$  are pivoted on a stud  $k_4$  fixed in the end of an elbow lever  $k_5$ , which is fulcrumed on a stud  $k_7$  and has a spring  $k_8$  attached to its lower end. This spring is also fastened to the lower end of a lever  $k_9$ , the other end of which rests against a roller  $i_3$  attached to the arm  $a_7$  that operates the lifter of the shedding mechanism.

When a new bar of the box chain is forced under the fingers, their rear ends are raised, as shown in Fig. 10, against the tension of the spring  $k_8$ , although the spring is at this time comparatively slack, because the roller  $i_3$  is then in its extreme position, as shown in the illustration.

The vibrator levers are not immediately raised when a new bar is forced under the fingers, but when the lock-knife is disengaged from them by its cam, the spring  $k_8$  will pull the fingers  $k, k_1, k_2, k_3$  down on the chain bar that is under them, the spring being under greater tension at this time, because the roller  $i_3$  has moved to the left and forced the lower end of the lever  $k_9$ , to which the spring  $k_8$  is attached, to the right. This allows the chain bar to make the proper selection of boxes to be raised, those fingers that are resting on a roller on the chain bar raising the vibrator levers to which they are connected, while those beneath which there is a washer allow the vibrator levers to which they are connected to remain down. A cam  $k_{10}$  to which a hand wheel  $k_{11}$  is attached is provided to operate on the lever  $k_9$ , so that the rear ends of the fingers may be conveniently held in a raised position when it is desired to place a new box chain on the loom.

**15. Setting and Timing.**—In setting any box motion, one of the most important points to be observed is to have each box, as it is raised or lowered, brought to the exact level of the race plate, since, if a box is too low, the shuttle, when leaving it, will strike the edge of the race plate, which will deflect its point upwards and be liable to result in its being thrown from the loom. The same thing will occur if the box is too high or if the back end of the box is very much higher than the front end, since, in these cases, the shuttle, in leaving the box, will strike forcibly on the race plate and rebound sufficiently to raise its point and throw it out. In leveling the boxes on the Crompton loom, the vibrator gears are first revolved so as to bring the fourth box into position, as shown in Fig. 15, and if the box is not exactly level with the race plate, the boxes are raised or lowered as required, until the correct position is obtained, the adjustment being made in this case by means of the nuts  $n_4$ . After having adjusted the fourth box, the vibrator gears are revolved so as to bring the first box into position, as shown in Fig. 12, and if this box is not exactly level with the race plate, it may be leveled by loosening the bolt  $l_{2s}$  and adjusting the casting  $l_{2s}$  so as to bring the boxes into the desired position. In leveling the first box, the fourth box is liable to be thrown out of level, so that the boxes should be returned to the initial position and the fourth box again adjusted by means of the nuts  $n_4$ ; then, in order to insure the first box remaining level, it should be brought into position again and further adjusted by means of the casting  $l_{2s}$ . After having adjusted the fourth and first boxes, the boxes are returned to the first-box position and the third box is then raised, as shown in Fig. 14. If this box does not come exactly level with the race plate, it may be adjusted by means of the stud  $l_{1s}$  until perfect. Next, the boxes are returned to the first-box position and the second box then raised by means of the vibrator gear that operates the lever  $l_{1s}$  with stud  $l_{1s}$ , as shown in Fig. 13. In this case it will be generally found that the adjustment of the stud  $l_{1s}$  to level the third box will also effect the leveling of the second box without further adjustment;

but should this not be so, the second box may be leveled by carefully adjusting either the stud  $l_{12}$  or the small bracket  $l_{20}$ . The object of this bracket is for fine adjustments of the second box, as explained, and also for further adjustment when the box chain wears by constant use. After leveling the boxes on one end of the lay, those on the other end should be leveled, which may be accomplished by adjusting the levers that operate them in the same manner as in the first instance.

The timing of the box motion is accomplished by means of the gear  $m_2$ , Figs. 11 and 17, that is fastened to the bottom shaft and imparts motion to the cylinder, or quill, gears  $m, m_1$ . To accomplish this timing, the lay is brought up until the daggers of the protector motion just touch their respective knock-off levers; then the gear  $m_2$  is loosened and turned until the boxes move  $\frac{1}{8}$  inch, whereupon the gear should be securely fastened to the bottom shaft. The box motion should be timed in this manner irrespective of the movement of the chain cylinder of the shedding and box mechanisms. In timing the lock-knife  $o_4$ , Fig. 11, the cam  $o$  should be loosened and turned so that the lock-knife will have returned to its locked position, engaging the ends of the vibrator levers, just before the cylinder, or quill, gears start to move, after which the cam should again be securely fastened.

#### PICK-DISCONNECTING DEVICE

**16.** Whenever the pick is lost or it is desired to make a pick-out, the reverse mechanism is thrown into operation, as previously explained; but when this is to be done it is necessary that the picking motion should be disconnected, so that as the sheds are reversed the picker sticks will remain idle with the shuttles at rest in the boxes. This allows the sheds to be reversed and the pick-out made without the shuttles interfering with the weaver. The boxes, however, are worked back with the sheds, so that when the loom is started again the proper color of filling will be inserted in the cloth. The pick-disconnecting mechanism is

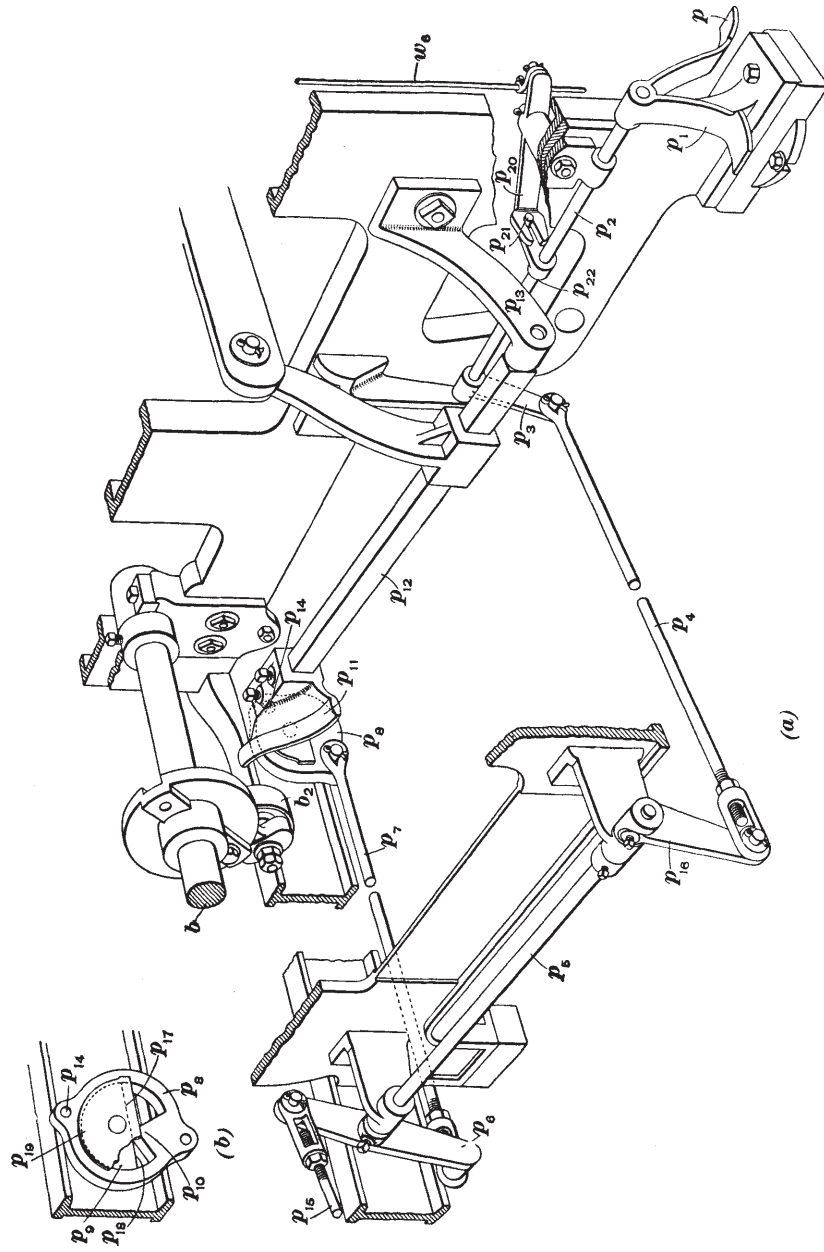

FIG. 18

shown in Fig. 18 (*a*) and (*b*). One end of the picking shaft  $p_{12}$  is carried in the ordinary manner by a casting  $p_{13}$ , but the other end is centered at  $p_{14}$  in a casting  $p_8$  that is in the shape of a ring and fits over a stationary semicircular casting  $p_9$ , Fig. 18 (*b*), on which it may turn. Attached to the lower end of the casting  $p_8$  is a rod  $p_7$ , Fig. 18 (*a*), that connects it with a double-ended lever  $p_6$ . A similar rod  $p_{15}$ , attached to the upper end of this lever is connected with a similar arrangement on the opposite side of the loom, with the exception, of course, that these parts are of the other hand. Lever  $p_6$  is fastened on a shaft  $p_5$ , to which is also fastened a casting  $p_{16}$ , connected by a rod  $p_4$  with another arm  $p_3$ . This arm is fast on a shaft  $p_2$ , to which is also attached a double treadle  $p, p_1$ . When the part  $p$  of the treadle is forced down by the weaver's foot, the rod  $p_7$  will pull the lower end of the casting  $p_8$  to the left, throwing the upper end, in which the picking shaft  $p_{12}$ , turns, to the right and drawing the picking shoe  $p_{11}$  out of the plane of the pick ball  $b_2$ , so that as the latter revolves with the bottom shaft  $b$  it will not come into contact with the picking shoe.

When, on the other hand, the treadle  $p_1$  is stepped upon by the weaver, the upper end of the casting  $p_8$  will be forced to the left and the picking shoe  $p_{11}$  thrown under the pick ball  $b_2$ , so that as the bottom shaft revolves the pick ball will strike the shoe and operate the picker stick. The extent of movement of the picking shaft and picking shoe is governed by a projection  $p_{10}$ , Fig. 18 (*b*), on the casting  $p_8$ . This projection strikes against the stationary semicircular casting  $p_9$  at  $p_{17}$ , when the picking shoe  $p_{11}$  is directly under the pick ball  $b_2$  so as to be operated by it, and against  $p_{18}$  when the picking shoe is moved from the plane of the pick ball. A plate  $p_{19}$  attached to the casting  $p_8$  holds it in contact with the stationary semicircular piece  $p_9$ . When the weaver desires to make a pick-out or find the pick, the reverse lever of the shedding mechanism is thrown over and the treadle  $p$  stepped upon. After the pick is found, the reverse lever is put back in its original position and the treadle  $p_1$  stepped upon.

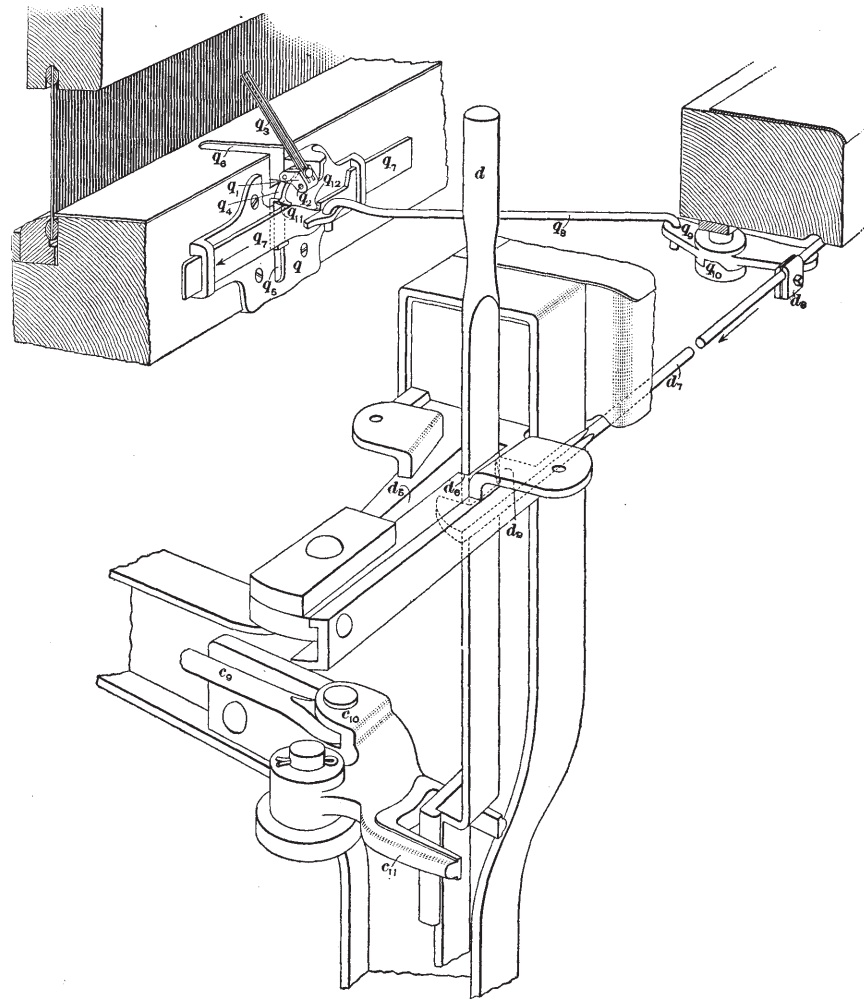

FIG. 19



## FILLING STOP-MOTION

17. The Crompton loom is equipped with a filling stop-motion of the type known as a *center stop-motion*. The motion is so arranged that the filling fork feels for every pick of filling, and if any pick is missing the loom is stopped; the arrangement of this mechanism is shown in Fig. 19. A casting  $q$  screwed to the lay of the loom supports a block  $q_1$  on a pivot  $q_2$ . Attached to this block is a two-prong fork  $q_3$  and also a small piece  $q_4$  that slides in a slot  $q_5$  in the casting  $q$ . The fork  $q_3$  is free to fall in a groove  $q_6$  cut in the lay, provided that the pick of filling does not support it and prevent this taking place. A sliding piece  $q_7$  is also supported by the casting  $q$  and is engaged by the piece  $q_4$ ; it is also connected by means of a rod  $q_8$  with a lever  $q_9$ , which is loosely supported on a stud fixed beneath the breast beam. The lever  $q_9$  is prevented from turning in one direction by a clutch  $q_{10}$  attached to the stud, but is free to move in the opposite direction. Its opposite end is in contact with a small dog  $d_8$  fastened to a rod  $d_7$ . This rod is in contact with the shipper lever  $d$ , which is retained in the position shown in Fig. 19 while the loom is running, by means of the notch  $d_6$  in the slot  $d_5$ .

The action of this mechanism is as follows: As the lay moves forwards, the slide  $q_7$  is moved in the direction indicated by the arrow, because the opposite end of the rod  $q_8$  remains stationary. The fork  $q_3$  will be lowered as soon as the piece  $q_4$  comes into contact with the inclined part of the slide. Should a pick of filling be under the fork, the fork will be supported by it and will in turn support  $q_4$ , so that the part  $q_{11}$  of the piece  $q_4$  will clear the notch  $q_{12}$  in the slide. Should, however, the pick of filling be absent, the fork will drop in the groove  $q_6$  in the lay and  $q_{11}$  will engage the notch  $q_{12}$ . When this happens, the slide  $q_7$  is prevented from moving in the direction of the arrow, and as the lay moves forwards the lever  $q_9$  will be turned in such a direction that it will push the piece  $d_8$  and rod  $d_7$  in the direction of its arrow. As this takes place, an inclined

piece  $d_6$  on the rod  $d_7$  forces the shipper handle  $d$  out of its retaining notch, and it springs to the end of the slot  $d_6$ , disconnecting the power from the loom and checking its motion.

---

**SETTING AND TIMING THE FILLING STOP-MOTION**

**18.** In setting the filling stop-motion, the first consideration is to see that the prongs of the fork  $q_6$  are not bent and that the fork falls freely into the groove  $q_6$  in the lay without touching either side. The fork, where it is swiveled on the pivot  $q_2$ , should be well oiled and the slide  $q_7$  and shoe  $q_{11}$ , engaging with it should work freely. In setting the filling stop-motion, the lay is pushed back so that the crank-shaft will be on the back center; the slide  $q_7$  is then placed at the point where it will have just moved the shoe  $q_{11}$  up to the highest position and thus have raised the filling fork to its extreme height. The stand under the breast beam that carries the stud on which the lever  $q_8$  is fixed is next loosened and adjusted so that the lever will be at right angles to the breast beam. With the shipper handle pulled on, the clamped collar  $d_6$  on the shipper rod  $d_7$  is set against the lever  $q_8$ . In pulling on the shipper handle to do this, it will be necessary to either throw off the belt or temporarily disconnect the shipping mechanism, in order not to start the loom. If the piece  $q_{11}$  is not now just at the commencement of the highest part of the slide  $q_7$ , a fine adjustment can be made by means of the clutch, or cam-collar,  $q_{10}$ .

---

**PROTECTOR MOTION**

**19.** The object of the protector motion is to check the motion of the lay and stop the loom in case the shuttle fails to reach the opposite box and is left in the shed. The mechanism is arranged as follows: A protector rod  $u$ , Fig. 20, carried in bearings on the front of the lay is equipped with a spring  $u_1$ , one end of which is attached to a collar setscrewed to the protector rod, while the other end is fastened to the lay. This spring tends to force the protector finger  $u_2$ , setscrewed to the rod, toward the binder

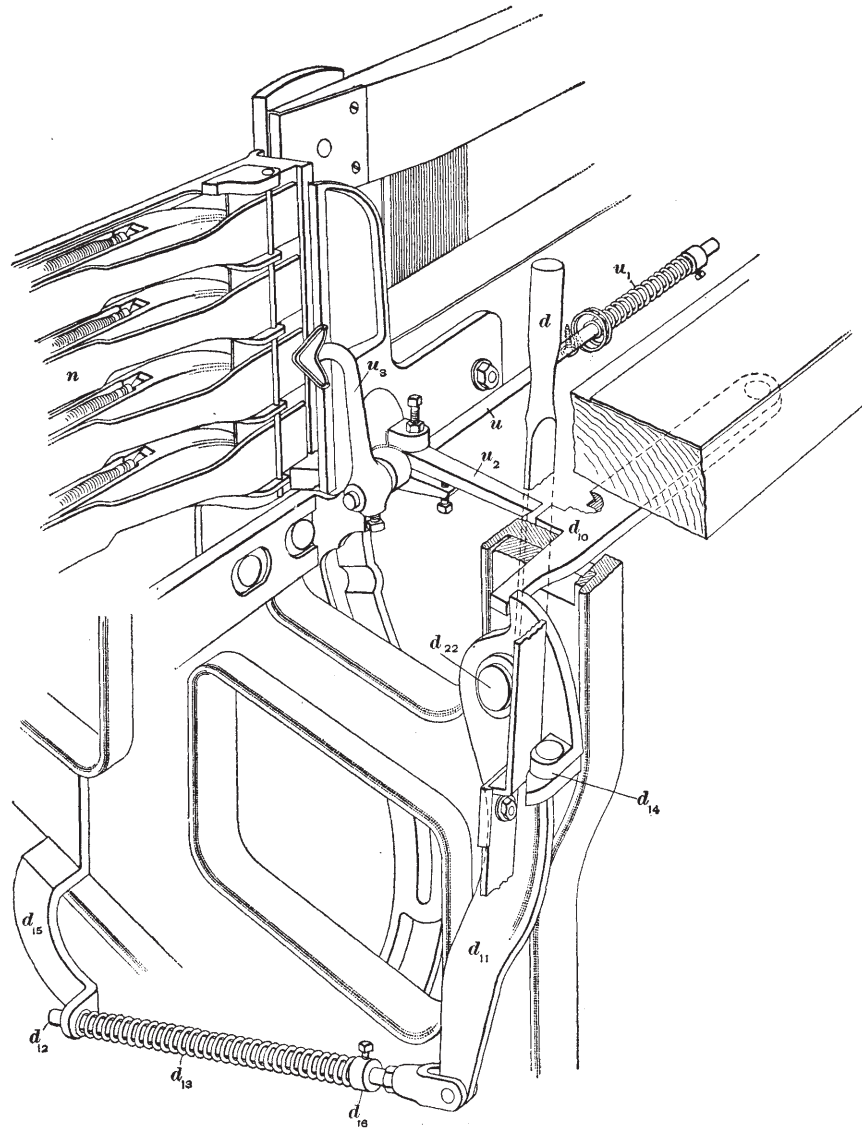

FIG. 20

of the shuttle boxes. Two daggers  $u_2$ , one on each side of the loom, are also attached to the protector rod. If the shuttle enters the box properly, the protector finger will be pushed forwards and the dagger will be lowered so that it will pass under a grooved lever  $d_{10}$  pivoted just beneath the breast beam; but in case the shuttle does not enter the box, the spring  $u_1$  will keep the protector finger pressed against the binder and the dagger will remain in a raised position, so that as the lay comes forwards it will engage the lever  $d_{10}$ . The end of this lever is in contact with a lever  $d_{11}$  carrying a projection  $d_{14}$  and pivoted on stud  $d_{22}$ . Its lower end is attached to the rod  $d_{12}$  that slides through the casting  $d_{15}$ .

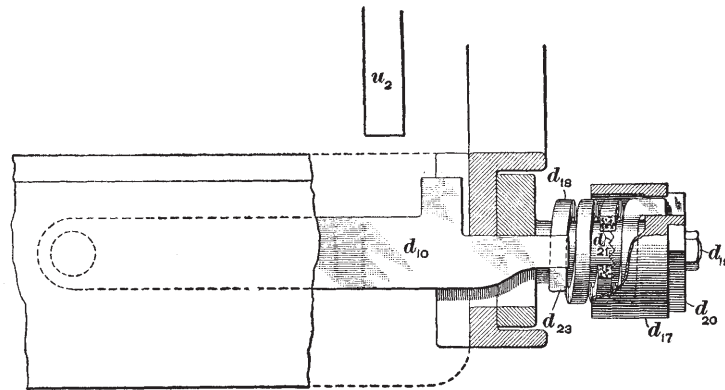

FIG. 21

Setscrewed to the rod  $d_{12}$  is a collar  $d_{16}$  against which rests one end of the spring  $d_{13}$ , the other end resting against the casting  $d_{15}$ . As the dagger comes into contact with the lever  $d_{10}$ , the projection  $d_{14}$  forces the shipper handle toward the rear and out of its retaining notch, so that the loom is stopped, the spring  $d_{13}$  serving to cushion the blow of the dagger. The cushioning device may be regulated by means of the collar  $d_{16}$ , which if moved on the rod  $d_{12}$  toward the casting  $d_{15}$  increases the tension of the spring and consequently its cushioning effect.

The arrangement for cushioning the blow of the dagger on the opposite side of the loom is slightly different, as shown in

Fig. 21. In this case the end of the lever  $d_{10}$  is in contact with the projection  $d_{23}$  on a very strong spiral spring  $d_{18}$ , which, as the dagger strikes the lever, serves to cushion the blow of the lay. This spring is carried in a casing  $d_{17}$ , so arranged that the spring can be tightened or loosened by placing a wrench on the nut  $d_{20}$  on the head of the casing, loosening the check-nut  $d_{19}$ , and turning the casing around, after which the check-nut can be tightened, the casing being held in any position by means of its toothed edge, as shown at  $d_{21}$ .

---

#### SETTING THE PROTECTOR MOTION

**20.** Care should be taken that the protector motion is kept in good working order and properly adjusted; otherwise a serious smash, involving considerable damage to the warp and consequent loss of time, is liable to occur. In setting the protector motion, the tension of the spring  $u_1$  should be so adjusted that the dagger will be firmly held in a raised position so as to engage the groove in the levers  $d_{10}$  as the lay is brought forwards. Next, with the shuttles out of the boxes, the projector fingers  $u_3$  are adjusted so that they will just touch the binders of the shuttle boxes; the shuttles are then placed in the boxes, and if the protector motion is properly set, the daggers will be lowered so as to clear the levers  $d_{10}$ . The protector motion should be adjusted so that it will work properly in connection with each box of the loom, and if necessary some of the binders may be bent slightly to secure a proper movement of the protector finger.

---

#### TAKE-UP MOTION

**21.** The take-up motion on the Crompton loom is arranged as shown in Fig. 22. The cloth passes over the breast beam, under the take-up roll  $v$ , which is usually covered with perforated steel fillet, over a guide roll  $v_1$ , and thence down under the cloth roll  $y$ , on which it is wound. Motion is imparted to the take-up roll as follows: Attached to the lay sword is a roller  $w$  working in a slotted arm  $w_1$ , that imparts motion to another arm  $w_2$ ; both arms are attached to the same stud and act as an elbow lever. Attached to  $w_2$  is a

rod  $w_3$ , on the end of which is fixed a pawl  $w_4$  that engages with a ratchet gear  $w_7$ . Fastened on the same shaft as the latter is a change gear  $w_8$  that meshes with a 60-tooth gear  $w_9$  fast on another shaft. Fast to this same shaft is a

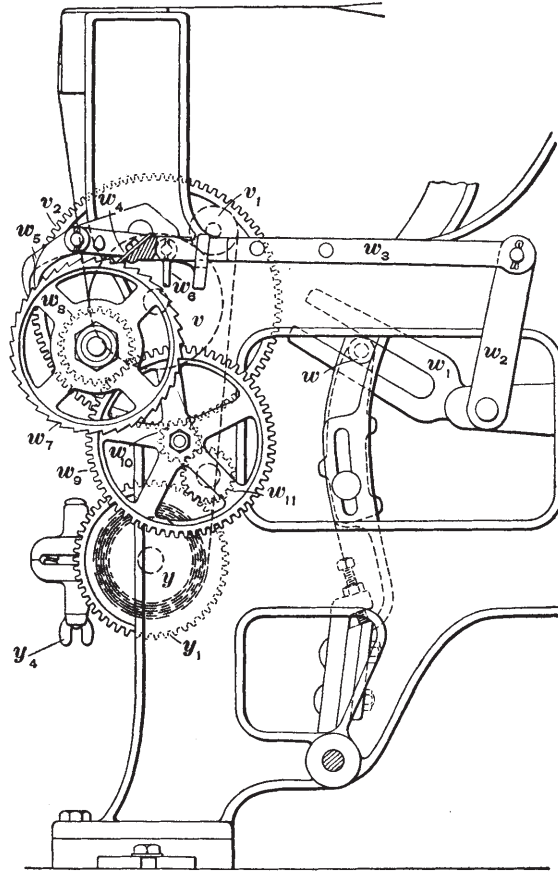

FIG. 22

12-tooth gear  $w_{10}$  that meshes with an 80-tooth gear  $v_2$  fast to the shaft of the take-up roll. As the lay moves forwards, the roller  $w$  depresses the lever  $w_1$ , throwing the arm  $w_2$ , rod  $w_3$ , and pawl  $w_4$  forwards and turning the ratchet gear forwards a distance of 1 tooth. This operates through

the train of gears mentioned and turns the take-up roll forwards; the repetition of these movements brings the cloth down over the breast beam at a uniform rate of speed. A double set pawl  $w_5$  prevents the ratchet turning backwards when the lay sword moves back and the rod  $w_3$  and pawl  $w_4$  are moved in the opposite direction.

In this take-up motion, the number of picks per inch in the cloth is altered by changing the ratchet gear  $w_7$  for one of more or less teeth, as desired. Two sizes of change gears  $w_8$ , containing either 24 or 12 teeth, may be used; if a 24-tooth change gear is used, the number of teeth in the ratchet

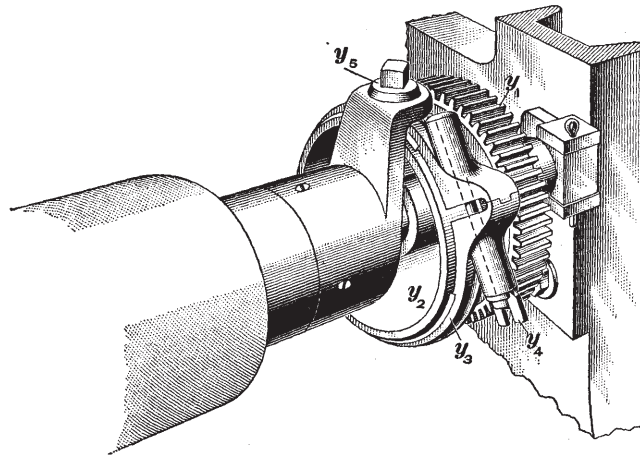

FIG. 23

gear  $w_7$  indicates the number of picks per inch in the cloth, but if a 12-tooth change gear is used, there will be twice as many picks per inch in the fabric as there are teeth in the ratchet gear.

The cloth roll is driven by means of the gear  $w_{10}$ , which besides meshing with  $v_2$  also meshes with the intermediate gear  $w_{11}$  that drives the gear  $y_1$  loose on the shaft of the cloth roll. Attached to this gear is a drum  $y_2$ , Fig. 23, around which a friction band  $y_3$  fastened to the cloth roll at  $y_4$  is placed. By tightening or loosening this friction by means of a thumbscrew  $y_5$ , the cloth may be wound on the



cloth roll with any desired tension; but it is always best to have the tension of the cloth between the guide roll  $v_1$ , Fig. 22, and the cloth roll  $y$  a little less than the tension of the cloth between the take-up roll  $v$  and the breast beam, since, if this is done, there will be no danger of the backlash in the gears resulting in uneven cloth.

In order to disengage the take-up motion while the loom is being reversed for the purpose of picking out or finding a loose pick, the following arrangement is provided: A lever  $w_{12}$ , Fig. 24, is fulcrumed on a stud  $w_{13}$  and has a slotted portion supporting the take-up rod  $w_3$ . Attached to

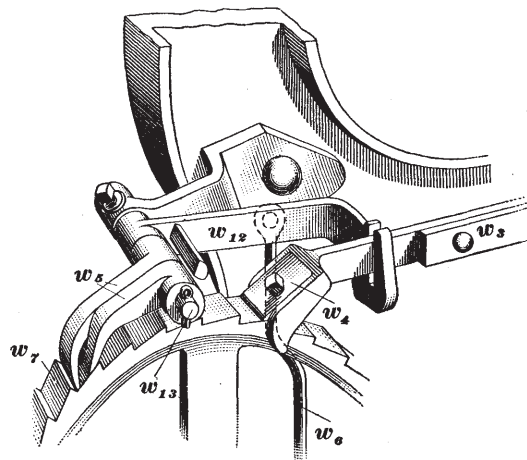

FIG. 24

this lever is a rod  $w_6$  that, as shown in Fig. 18 (a), is attached to a lever  $p_{20}$ . This lever is operated on by a pin  $p_{21}$  fixed in an arm  $p_{22}$  and engaging with a slot in the extremity of  $p_{20}$ . Thus, as the treadle  $p$  is pressed down by the weaver when the picking motion is disconnected, the rod  $w_6$  is raised, which results in the rod  $w_3$ , Fig. 24, being raised and the pawl  $w_4$  being disengaged from the ratchet gear  $w_7$ . Consequently, if the loom is run with the picking motion disconnected, the pawl will not be in contact with the ratchet and the cloth will not be wound down by the take-up motion.

## LET-OFF MOTION

22. The warp let-off motion on the Crompton loom is a regular friction let-off, with the exception that a system of double leverage is used.

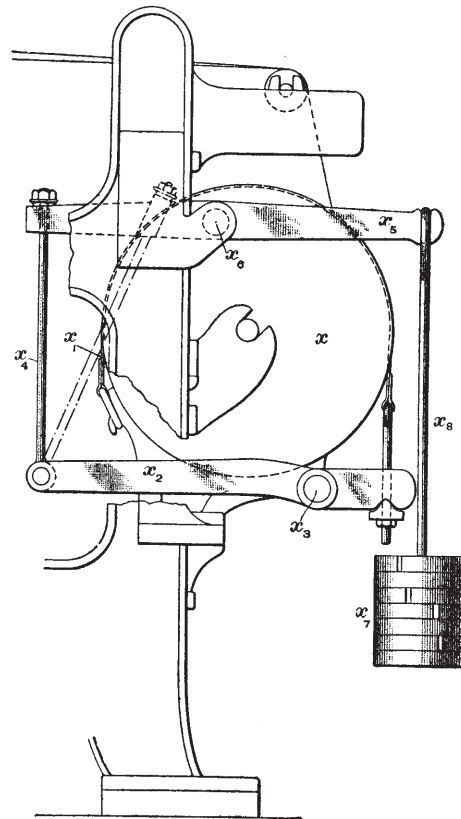

FIG. 25

This arrangement, as shown in Fig. 25, consists of a friction strap  $x_1$ , passing around the beam head  $x$ . One end of this friction strap is attached to the lever  $x_2$ , fulcrumed at  $x_3$ , while to the other end of this lever a rod  $x_4$  is attached. This rod is connected with the end of a lever  $x_5$ , fulcrumed at  $x_6$ , and supporting at its other extremity a rod  $x_8$  on which weights  $x_7$  are placed. The degree of friction on the beam may be regulated by the number of weights placed on the rod. If a greatly increased amount of friction is

desired on the beam, the rod  $x_4$  may be moved from the extremity of the lever  $x_5$  to a position nearer its fulcrum, as indicated by the dotted lines in the illustration. In this case, the distance from the fulcrum to the rod being shortened, the tension on the friction band is greatly increased.

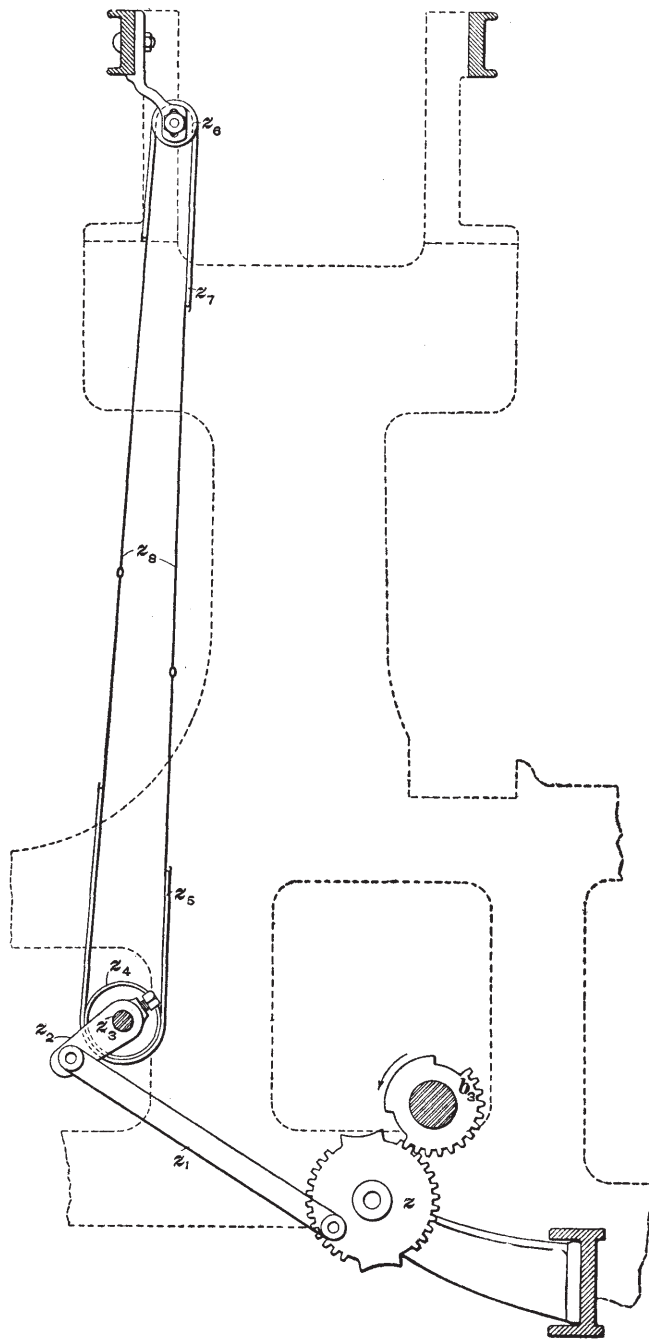

FIG. 26

## SELVAGE MOTION

**23.** In cases where a fabric is being woven with a loose weave, it is desirable to use a selvage motion for producing the selvages, since in this manner a much firmer and better selvage can be obtained. The selvage motion applied to the Crompton loom is shown in Fig. 26. Attached to the bottom shaft of the loom is a segment gear  $b$ , that engages with another correspondingly cut gear  $z$  attached to a separate shaft. Fastened to this latter gear is a rod  $z_1$  that connects with an arm  $z_2$  setscrewed to the shaft  $z_3$ , which extends across the loom. Attached to this shaft at each side of the loom is a boss  $z_4$ , to which is attached a strap  $z_5$ . A similar boss  $z_6$  carried on the arch of the loom supports a strap  $z_7$ , and the selvage heddles  $z_8$ , which are also attached to the strap  $z_5$ . As the bottom shaft revolves with the gear  $b$ , driving gear  $z$ , the connecting arm  $z_1$  produces a partial rotary motion of the shaft  $z_3$ , by means of the arm  $z_2$ , which serves to raise and lower the selvage heddles and ends. The gear  $b$ , will drive the gear  $z$  until the portion that has no teeth comes in contact with the portion of the gear  $z$  that has no teeth, whereupon a dwell will be imparted to the selvage motion. The selvage harnesses in this case are open to their greatest extent.

## TIMING THE SELVAGE MOTION

**24.** The principal point to be noted in timing the selvage motion is to have the selvage ends move in unison with the bulk of the warp, which may be accomplished by loosening the gear  $b$ , on the bottom shaft and turning it so that with the lay 1 inch from the fell of the cloth the selvage ends will just start to open with the body of the warp to form the shed, whereupon the gear should be tightened in this position.

If the selvage ends do not rise and fall an equal distance, so as to move with the rest of the warp uniformly, the arm  $z_2$  may be loosened and the shaft  $z_3$  turned until the selvage heddles assume the proper position.