

DOBBIES

Serial 495

Edition 2

	<i>Pages</i>
Introduction	1- 4
Single-Cylinder Dobby	5-18
Construction	5-10
Method of Driving	11-12
Operation	13
Variations of Construction	14-17
Positive and non-positive; Double-lift and single-lift dob- bies; Double-index and single-index dobbies; Pawl-and- ratchet drive; Right-hand and left-hand dobbies.	
Double-Cylinder Dobby	18-24
Construction; Repeat motion; Operation.	
Building Harness Chains for Dobbies	25-26
Fixing	27-33
Timing and Setting the Single-Cylinder Dobby.....	27-31
Setting the dobbie crank-shaft; Setting the knives and cylinder; Regulating the shed; Lift of the harnesses; Skipping.	
Timing and Setting the Double-Cylinder Dobby	32-33
Power and Speed	33

DOBBIES

Serial 495

Edition 1

INTRODUCTION

1. When harnesses are employed, all the warp ends that are drawn through any one harness are raised and lowered together as that harness is raised and lowered; that is, each warp end drawn through this harness is manipulated in exactly the same manner as every other end drawn through it. The number of harnesses that can be operated by a cam-loom is limited by the amount of space available for the cams; and as cams take up considerable room, it will readily be seen that cam-looms are limited to a small number of harnesses. It may also be stated that where looms are frequently changed from one weave to another it is necessary to keep a large variety of cams on hand, and in addition the changing of a cam-loom from one weave to another involves considerable work.

For these reasons it is not the general custom in America to run more than 6 harnesses in a cam-loom, and consequently not more than six different interlacings of the ends in the entire warp can be obtained, no matter how many ends the warp may contain. Therefore, when it is desired to weave a pattern in which it is necessary to manipulate more than 6 ends differently, some mechanism other than cams is used to operate the harnesses. If the number of ends that work differently exceeds 6 but does not exceed 25, a **dobby** is generally employed. The method of drawing the warp ends through the harnesses is the same for a dobbie loom as for a cam-loom; consequently, the number of harnesses that

are used limits the number of ends that can work differently, the chief advantage of a dobbie over cams being that with the former more harnesses can be manipulated. The adoption of 6 harnesses and 25 harnesses as the limits of the scope of a dobbie is not arbitrary, as the numbers may vary somewhat, according to circumstances.

VARIETIES OF SHEDS

2. The manner in which the different mechanisms, employed to move the harnesses, form the shed in the loom will be found to differ largely; therefore, before dealing with the parts of the dobbie it is advisable to describe the various kinds of sheds that are produced.

3. **Open Shed.**—Fig. 1 illustrates the positions occupied by the warp ends in open shedding. In this style of shed-



FIG. 1

ding, on one pick the warp ends form the top and bottom lines *b*, *a*. After the filling has been inserted, if there are any ends in the bottom line *a* that are required to be moved to the top line *b* on the next pick, these ends alone will be raised, while the remaining ends that form the bottom line will be left in this position. Similarly any ends in the top line *b* that are required to be moved to the bottom line *a* will be lowered, the remaining ends being held stationary at the top line *b*. Consequently, in this form of shedding only those ends that require changing are moved, and those ends that it is not necessary to change remain stationary. This form of shedding produces the least strain on the yarn, since the ends in the top shed are moved only when they are required to be down, and the ends in the bottom shed are raised only when they are required to be up. The least strain is also brought on the shedding mechanism of the

loom with this style of shedding, as the harnesses that are being lowered balance to a certain extent those harnesses that are being raised. This style of shed can also be formed in the least time, since there is no unnecessary movement given to the yarn.

4. Close Shed.—Fig. 2 illustrates the method of forming a **close shed**. In this style of shedding all the yarn assumes the position shown by the line *a* between each two picks of the loom. Thus, all the yarn that forms the top shed on one



FIG. 2

pick is lowered to the bottom shed after each pick, where all the yarn assumes the same position. Then those ends that it is desired to have up on the next pick are lifted to the top line *b*. Consequently, if any yarn on one pick assumes the position shown by the dotted line *b* and it is desired to have it assume the same position on the next pick, it must be lowered to the bottom shed and then raised again. It will be seen that with this form of shedding certain ends must move through twice as much space as is necessary with an open shed.

5. Split Shed.—Fig. 3 illustrates the positions assumed by the warp ends when forming a **split shed**. In this case all the warp yarn assumes the position shown by the line *a* after each pick of the loom. Those ends that are required to be up

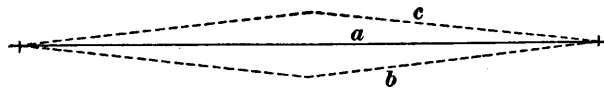

FIG. 3

on the next pick are raised from the center *a* to the top line *c*, while those ends that are required to be down on the same pick are lowered from the center line *a* to the bottom line *b*. Consequently, with this form of shedding, any warp ends that are in the top shed on one pick and that it is desired to lower

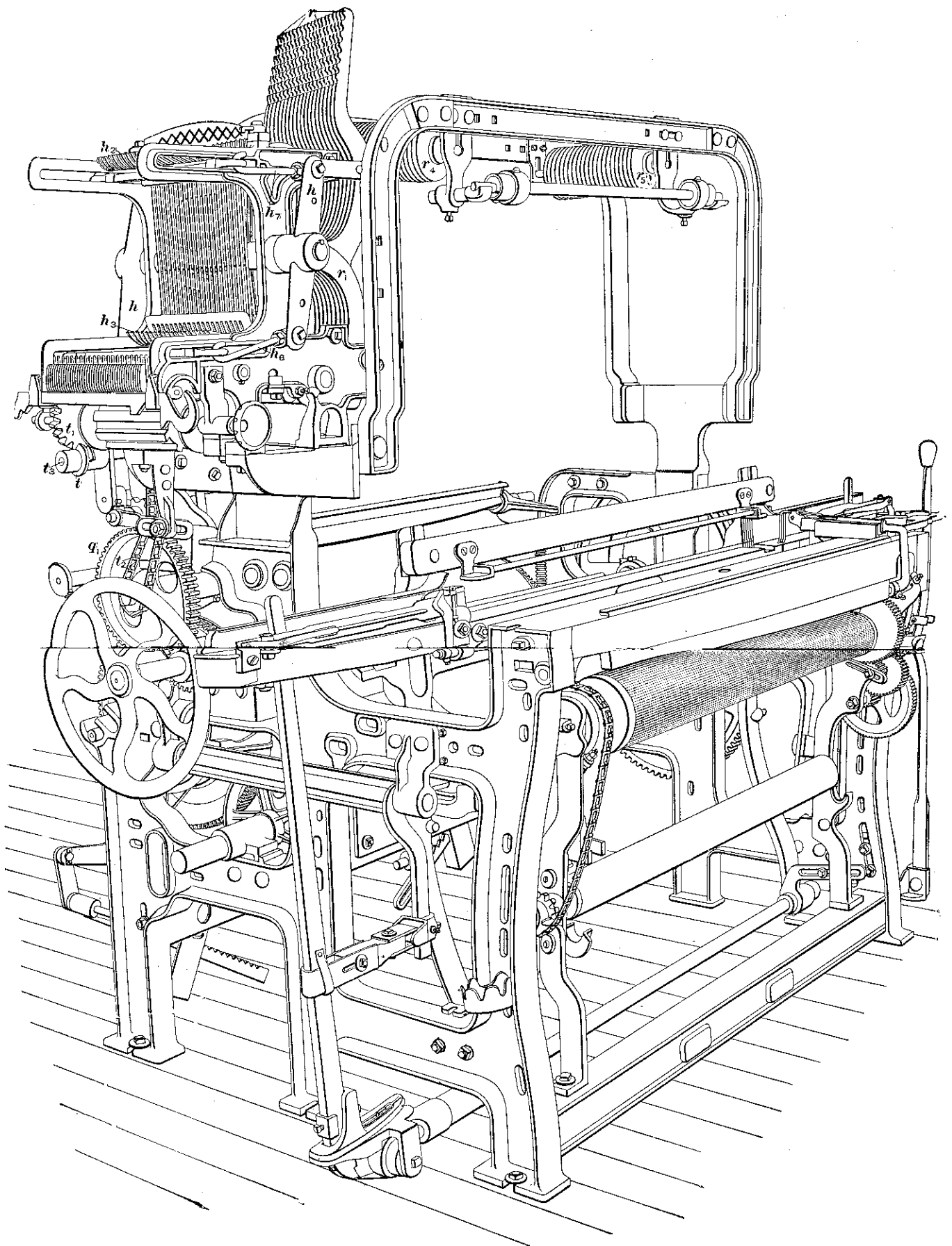

FIG. 5

to the bottom shed on the next pick are dropped to the center *a* and then continue in their movement to the bottom line *b*, while those ends that are in the bottom shed on one pick and are to be moved to the top shed on the next pick are raised to the center *a* and continue their movement to the top line *c*. Any ends that are in the top shed on one pick and are to be in the top shed on the next pick are lowered to the center *a* and then raised to the top line *c*. Any ends that are in the bottom shed on one pick and that are to be in the bottom shed on the next pick are raised to the center line *a* and then lowered to the bottom line *b*. This form of shedding is produced in about the same time as an open shed, since the yarn can be raised from the bottom to the center line and returned to the bottom again in the same time that it takes an end to drop from the top line to the bottom line, the same being true of any of the ends in the top line that are to be dropped to the center and then again raised to the top.

6. Compound Shed.—Fig. 4 illustrates the positions assumed by the warp ends in forming a **compound shed**. In this form of shed, any ends that are to remain in the bottom shed for more than one pick remain stationary at the



FIG. 4

bottom line *a*; but any ends that are in the top shed *b* on one pick and are to be a part of the same shed on the next pick are lowered to the line *c* and then raised to the line *b*; while those ends that are in the top shed on one pick and are required to form a part of the bottom shed on the next pick continue their movement to the bottom line *a*. Those ends that are a part of the bottom shed on one pick and are to be a part of the top shed on the next pick are raised from the bottom line *a* to the top line *b*. In this form of shedding certain harnesses tend to balance others, since during the time that the ends in the top shed are dropping, those ends

in the bottom shed that are to be up on the next pick are being raised.

7. It should be understood that the different formations of sheds described are not all employed to an equally large extent, since some are found only on certain types of looms. Most of the dobbies as made today form an open shed, and unless otherwise mentioned, all references to shedding will be understood to refer to this type.

SINGLE-CYLINDER DOBBY

CONSTRUCTION

8. In 1867, Messrs. Hattersley & Smith, of England, patented a dobbie that was far superior to anything that had been produced previously. Its extensive use, however, soon brought to light certain defects that were later improved. Yet the dobbie as manufactured today is, in its fundamental principles, simply a modification of the original invention, strengthened and improved in order to meet the increased demands placed on it.

Fig. 5 is an illustration of a loom with a dobbie attached, a front view of the dobbie being shown in this instance. Fig. 6 is a rear view of the dobbie alone. Reference should also be made to Fig. 7, which shows a section through the same dobbie. As the same letters are used for the same parts in Figs. 5, 6, and 7, it will be well to examine these parts carefully in all the illustrations, so that a better knowledge of the construction of the machine may be obtained. It will be noticed from Fig. 5 that the loom itself is very similar to the ordinary plain loom, with the dobbie attachment, the object of which is to regulate the rise and fall of the harnesses placed at one side.

One of the harnesses *s* operated by the dobbie is shown in Fig. 7. To the bottom of the harness are attached harness straps *s*₁, to which are connected springs *s*₂, which are

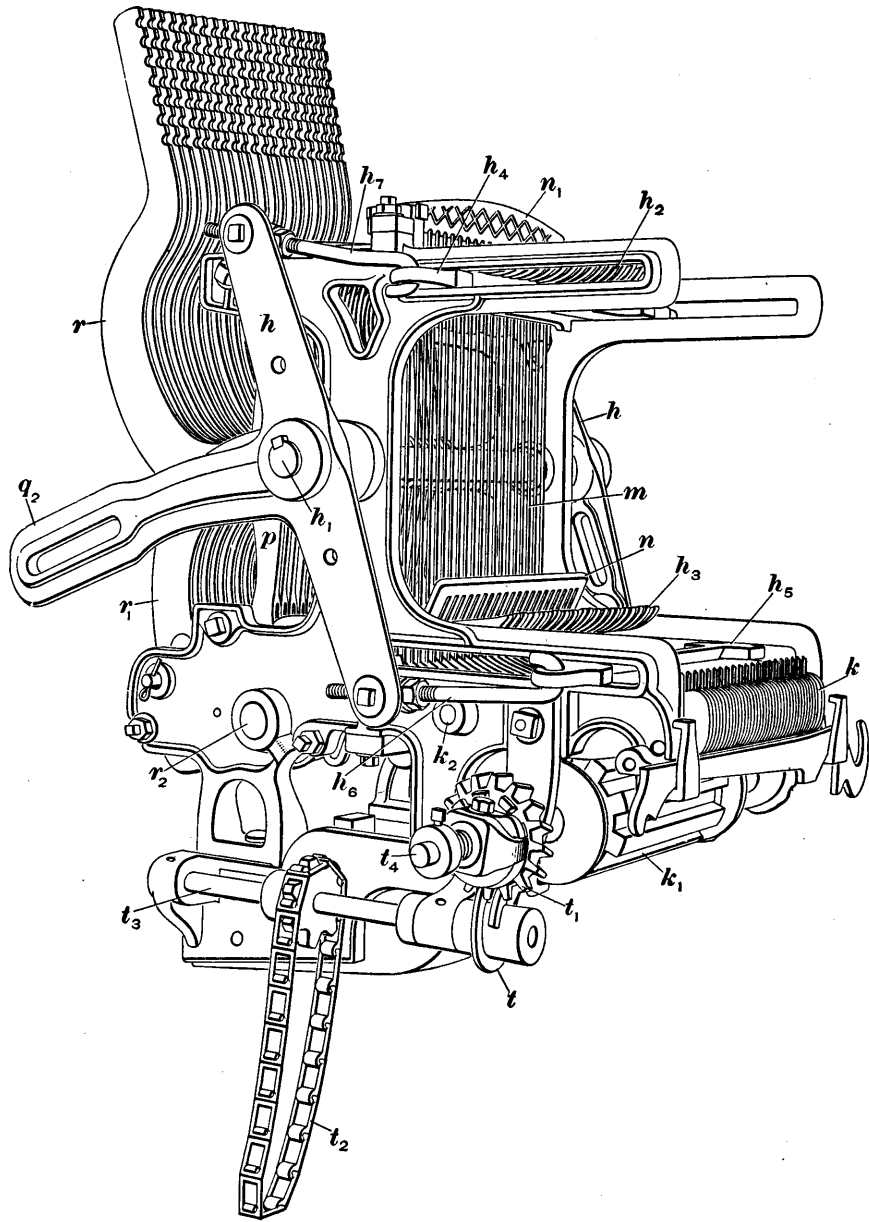
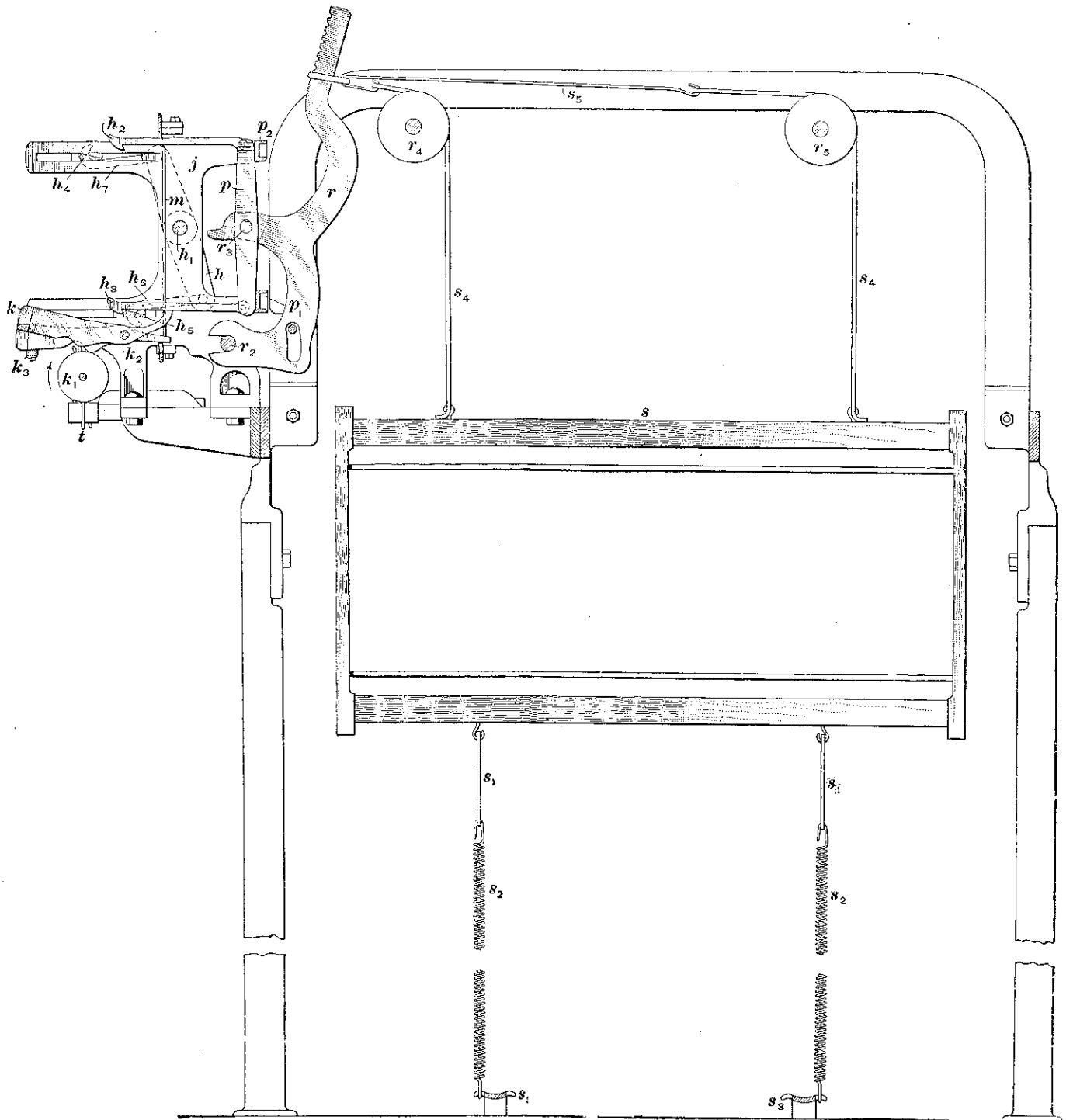

FIG. 6



ILL 8B-1764A

FIG. 7

connected to castings s , screwed to the floor. Connected to the top of the harness are harness straps s , that pass over the sheaves r , r , and are attached to the wire s , which in turn is connected to the harness lever r . Although Fig. 7 shows but 1 harness and 1 harness lever, it should be understood that dobbies are constructed with different numbers of levers up to 25 and that the number of harnesses possible to be operated by a doobby depends on the number of harness levers that it contains. The doobby shown in Figs. 5 and 6 contains 20 levers, and it is therefore possible to operate 20 harnesses in a loom having this doobby attached. It should also be noted in this connection that it is possible to operate any other number of harnesses under 20 with the same doobby, since it is not necessary to use all of the levers of the doobby.

Suppose, for illustration, that instead of 1 harness and 1 lever, as shown in Fig. 7, there are 12 harnesses operated by 12 independent levers. Then if some of these harnesses are raised and the others lowered, a shed will be formed by the warp yarn drawn through the harnesses; and if the shuttle is thrown across the lay through this shed and inserts a pick of filling, these two series of yarn—warp and filling—will interlace with each other and form cloth. Continuing further, if it is possible to have any of these 12 harnesses up or down on any pick, it will be readily seen that the sheds may be formed in a variety of different ways.

Referring again to Fig. 7, the lower end of the harness lever r fits over a rod r , that is supported by the two side pieces of the doobby. This rod is also shown in Fig. 6. At the point r , a boss on the lever projects into the jack p and is held firmly in position by lever guides r , Figs. 5 and 6, that press against the two outer levers. These guides may be tightened or loosened by means of setnuts.

When the jack p is in the position shown in Fig. 7, its upper arm rests against the top girt p , while its lower arm rests against the bottom girt p . If any force acts on the top arm of the jack to draw it to the left of the position it occupies in Fig. 7, then its lower arm resting against the

bottom girt p_1 , will cause the jack to act as a lever and draw with it the harness lever r , thus raising the harness. The same action will take place if the lower arm of the jack is drawn to the left while its upper arm is resting against the top girt p_2 .

A very important action of the jack that should be noted in this connection is as follows: Suppose that the upper arm has moved to the left and raised the harness, but that as this upper arm is returning to its position against the top girt the lower arm is being moved to the left; then, since the movement of the upper arm in one direction is equal to the movement of the lower arm in the other, the harness lever and the harness that it controls will remain at its upper position. By this means the harness may be held up for any length of time that may be desired. This is termed a *double-lift* arrangement; a dobbie capable of giving such a lift to the harnesses is known as a *double-lift dobbie* and, as will be readily seen, produces an open shed.

9. Connected to the top of the jack is the top hook h_1 , while a bottom hook h_2 is connected to the bottom of the jack. These hooks are so shaped at their outer ends that the top hook is capable of engaging with the top knife k_1 , while the bottom hook is capable of engaging with the bottom knife k_2 , provided that the hooks assume the necessary position. The knives k_1 , k_2 slide back and forth in slots cast in the sides of the dobbie, and are operated, as seen in Figs. 5 and 6, by two rockers h , to which they are connected by top and bottom knife hooks h_1 , h_2 , respectively. These rockers are held in position by a rod h_3 , to which they are keyed and which rests in the two sides of the dobbie. In speaking of the knives of the dobbie, they are said to be in or out; to be on their inward throw or on their outward throw. For example, if the top knife is moving toward the loom it is said to be on its inward throw, and when it has moved to the limit of its throw in this direction it is said to be in; on the other hand, when it is moving away from the loom it is said to be on its outward throw, and when it has reached the limit

of its movement in this direction it is said to be out. The same remarks apply to the bottom knife.

The outer ends of the hooks h_1, h_2 are controlled by the dobbie fingers k ; these are held in position at their inner ends by a rod k_2 that passes through them, while the outer ends of the fingers, which are made slightly thinner, pass between wires and rest on a bar k_3 of the dobbie frame. A better idea of the shape of the fingers may be obtained by referring to Fig. 8, which gives a view of the fingers themselves. With this style of dobbie, which is known as *double-index*, there are two fingers for each jack of the dobbie; one finger has a point a_2 on which the bottom hook rests, as shown in Fig. 7, while the other finger has a point a_1 on which

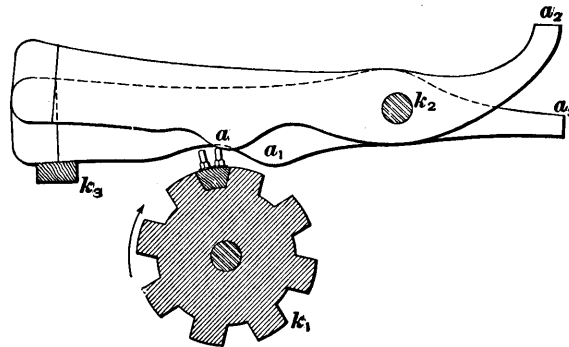

FIG. 8

a wire m , Fig. 7, rests; the top hook h_1 bears directly on the upper end of this wire. Thus one finger controls one hook independently of the other. That part of each finger from the point where the rod k_2 passes through it to its outer end is sufficiently heavy to overbalance the inner part together with the weight of the hook resting on it. Consequently, provided that the outer ends of the fingers are not lifted, they will rest on the bar k_3 , Figs. 7 and 8; when the fingers are in this position, the points a_1, a_2 , Fig. 8, will be as high as it is possible for them to rise. The connections to the hooks are such that when the fingers are in this position the outer ends of the hooks h_1, h_2 , Fig. 7, will not engage

with the knives h_4, h_5 . Placed directly beneath the fingers is the grooved cylinder k_1 , Fig. 6. This cylinder, known as the harness-chain cylinder, carries the harness chain, which consists of wooden bars linked together at their ends. One bar of a chain that would be used with double-index fingers is

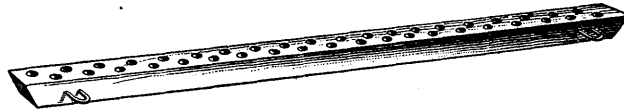

FIG. 9

shown in Fig. 9. These bars are so shaped that they fit readily into the grooves cut in the chain cylinder and are flush with its surface when under the fingers. Each bar

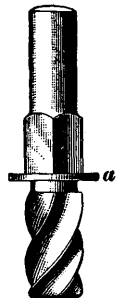

FIG. 10

contains two rows of holes, each row containing as many holes as there are levers in the dobbie. The holes in each row are so spaced that when the bar is placed on the cylinder and brought under the fingers, each hole in the first row will be directly beneath a finger of the set operating the bottom hooks, while each hole in the second row will be directly beneath a finger of the set operating the top hooks. If it is desired to raise the outer end of any finger in the dobbie, a peg, which may be made either of wood or steel, is inserted in the hole corresponding to that finger.

Fig. 10 shows a peg made of steel; its shoulder a comes flush with the upper surface of the bar when the peg is in



FIG. 11

place. These pegs may be readily inserted or taken out by means of a peg puller, such as is shown in Fig. 11, which contains a square hole that fits over the middle part of the peg. In a great many cases peg pullers are not used, the pegs being inserted with a hammer and taken out with pliers.

METHOD OF DRIVING

10. Dobby Crank-Shaft.—Referring again to Figs. 5 and 6, the manner in which the different parts of the dobbie receive motion will be explained. On the end of the crank-shaft of the loom, Fig. 5, is a gear g of 30 teeth that drives a gear g_1 of 60 teeth; the gear g_1 is on a short shaft that is known as the crank-shaft of the dobbie. Connected to the inner end of the dobbie crank-shaft by means of a crank-arm and working on a swivel is a connecting-rod, which at its other end is connected to the rocker-arm q_2 of the rocker h , Fig. 6. The rocker-arm and rocker together are sometimes spoken of as the **T** lever. As the connecting-rod is moved up and down by the crank-arm on the dobbie crank-shaft, it will impart an up-and-down movement to the rocker-arm q_2 , thus giving a rocking motion to the rocker h . Since the gear on the dobbie crank-shaft contains twice as many teeth as the gear on the loom crank-shaft, these two parts are geared 2 to 1 and will bear the same relation to each other as do the cam- and crank-shaft of a plain loom. Consequently, the dobbie crank-shaft will make one complete revolution during every 2 picks of the loom, which will cause the top part of the rocker h to be moving out on one pick and in on the next. This point should be carefully noted when endeavoring to understand the action of the dobbie as a whole.

In some cases the rocker-arm of the dobbie is connected directly with and driven by the bottom shaft of the loom, thus receiving the same speed with relation to the crank-shaft as one connected in the manner described above. Dobby crank-shafts are spoken of as being on their top, bottom, front, or back centers.

11. Cylinder Drive.—Referring to Fig. 5, there will be noticed on the outer end of the dobbie crank-shaft a sprocket gear that, by means of a chain t_2 , drives a short side shaft t_3 , Figs. 5 and 6. The shaft t_3 carries a worm t that drives a worm-gear t_1 on the cylinder shaft t_4 , Fig. 6, carrying the

harness-chain cylinder k_1 . The manner in which this worm t drives the cylinder k_1 is shown more clearly in Fig. 12.

The worm-gear t_1 , which has a series of projections on one of its sides, works loosely on the cylinder shaft t_4 . Set-screwed to the cylinder shaft is a clutch arrangement consisting of a plate t_5 to which is hinged a lever t_6 that projects through a slot in the plate t_5 and engages with one of the projections on the worm-gear t_1 . The lever is kept pressed against the worm-gear by means of the spring t_7 , which is loose on the cylinder shaft, but is compressed between the lever

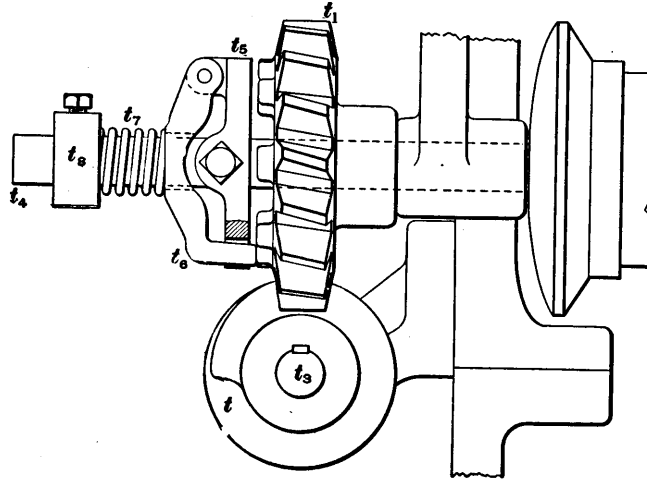

FIG. 12

and the collar t_8 . In Fig. 12, the lever t_6 is shown in the position that it assumes when thrown out of connection with the projections on the worm-gear t_1 , but it should be understood that when the cylinder is operating, the lever t_6 will be in position between two of the projections on t_1 . So long as the cylinder is free to rotate, the worm-gear t_1 imparts motion to the cylinder shaft by means of the clutch, but in case any obstruction prevents the revolving of the cylinder, the lever t_6 is thrown out of connection with the projections of the worm-gear t_1 ; the spring t_7 allows this to be done readily.

The worm t is so shaped that in revolving it gives to the

cylinder an intermittent motion; this motion brings the first row of pegs in the pattern chain under one set of fingers of the dobbie at the point a , Fig. 8. At this point the cylinder will pause, owing to a straight part of the worm t working in the worm-gear t_1 . The worm t continuing to revolve will next turn the cylinder until the pegs in the second row of the bar come under the other set of fingers at the point a_1 , Fig. 8. At this point the cylinder is again allowed to stop. The object of giving this pause to the cylinder is to allow the pegs in the chain to hold up the outer ends of the fingers for a sufficient length of time to allow the knives to engage with those hooks that are down.

OPERATION

12. In order that the operation of the dobbie as a whole may be better understood, the action of the different parts that takes place during one or more picks of the loom will be explained with reference to Fig. 7. Suppose that the different parts assume the positions shown in this illustration and that a peg in the pattern chain comes under the finger operating the bottom hook h_2 . This peg throwing up the outer end of the finger allows the inner end, on which the hook rests, to drop; this allows the outer end of the hook h_2 also to drop. As the dobbie crankshaft revolves and, through the connecting-rod, operates the rocker h , the lower arm of the rocker h in being pushed out will carry with it the knife h_1 , which will engage with the hook h_2 and thus take with it the lower end of the jack p . The upper end of the jack bearing against the girt p_1 will be fulcrumed at this point, so that as its lower end is brought out by the action of the knife it will raise the lever r , which is connected to the jack p at the point r_1 . The lever r in being pulled outwards will, through the strap connections, raise the harness connected to that lever. If on the next pick it is desired that this harness be down, no peg will be inserted in the pattern chain to operate the finger that connects with the top hook h_1 ; consequently, the knife h_1 , which

is moving out on this pick, will escape the hook h_1 , and the bottom knife h_2 in returning will allow the pull of the springs attached to the bottom of the harness to pull the harness down to its lowest position. This will cause the warp ends drawn through this harness to form a part of the bottom shed. If, on the other hand, it is desired to have this harness remain up on the second pick, a peg is inserted in the pattern chain to raise the outer end of the finger operating the top hook. The outer end of the finger in being raised causes its inner end to drop, and this motion, being imparted to the top hook h_1 , through the wire m , allows this hook to engage with the top knife and be carried out on this pick; this brings the upper arm of the jack p outwards and holds the harness at its upper position.

VARIATIONS OF CONSTRUCTION

13. It should be understood that all dobbies are not constructed according to the descriptions given, all of which apply to the dobbie illustrated in Figs. 5 and 6. Dobbies as made today are of several varieties; such as *positive*, *non-positive*; *single-lift*, *double-lift*; *single-index*, *double-index*. The dobbie that has been described is known as a non-positive, double-lift, double-index dobbie.

14. Positive and Non-Positive.—Dobbies are said to be **positive** or **non-positive**, according to whether they do or do not positively control both the raising and lowering of the harnesses. It will be remembered that in the case of the dobbie illustrated in Fig. 7, the dobbie lever r positively raises the harness, while springs s , are introduced to lower the harness as the pull of the harness lever is taken away. Dobbies, however, are sometimes constructed in such a manner that the harness lever will not only lift the harness positively, but also lower it. As this type of dobbie is not frequently met with, it will not be dealt with here.

15. Double-Lift and Single-Lift Dobbies.—Dobbies are said to be **double-lift** or **single-lift**, according to

whether or not more than one part of the dobbie can operate the harness lever. By referring to Fig. 7, it will be seen that the harness lever may be raised by either the top or the bottom hook, these two hooks being attached to the same jack and this jack operating but 1 harness lever. Consequently, the dobbie in this case is a double-lift machine. If, on the other hand, the jack is operated by only a single hook, the dobbie is single-lift. In a single-lift dobbie a harness cannot be held up for more than 1 pick, and if a harness is up on one pick and it is desired to have the same harness up on the next pick it must be lowered to the bottom and again raised to the top. On this account, double-lift machines can be speeded higher without producing any more strain on the warp yarn, since the yarn has no unnecessary movement. Single-lift machines must, of necessity, form a close shed, while a double-lift machine ordinarily forms an open shed. However, by the application of special mechanism, or by making other changes, the ordinary double-lift dobbie can be caused to make a close shed. It has, therefore, become customary to consider as a single-lift machine, any dobbie that makes a close shed, and as a double-lift dobbie any machine that forms an open shed, irrespective of the actual construction of the machine.

16. Double-Index and Single-Index Dobbies.—Dobbies are said to be **double-index** or **single-index** according to whether or not there is a separate index finger for each hook, both top and bottom. It will be remembered that with the dobbie illustrated in Fig. 7 there is an index finger for each hook of the machine, making the dobbie double-index. If one finger controlled both the top and bottom hooks that are attached to the same jack, the dobbie would be known as single-index. The finger used in such a dobbie is shown in Fig. 13. It contains a point a_2 on which rests the bottom hook, while a wire m that sets in the slot a_2 extends to, and supports, the top hook. Consequently, if the outer end of this finger is raised, thus lowering its inner end, both the top and bottom hooks will be in position to

engage with the knives. A bar of the pattern chain used on such a dobby is shown in Fig. 14; it contains but a single row of holes. With this arrangement, the driving mechanism of the chain cylinder is so arranged that it forces a new bar

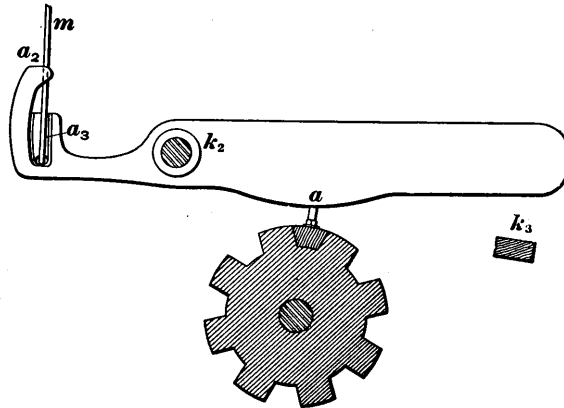

FIG. 13

of the pattern chain under the fingers for each pick of the loom. The chief advantage that the double-index has over the single-index is that with the former one bar of the pattern chain serves for 2 picks of the loom, while with the latter, one bar serves for only 1 pick.

17. Pawl-and-Ratchet Drive.—A method of driving the harness-chain cylinder that differs from the one described is illustrated in Fig. 15. Connected to the lower arm of the rocker h is a casting t , that carries the pawl t , which works

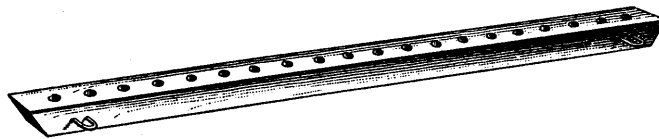

FIG. 14

in the teeth of the ratchet gear t_1 on the cylinder shaft t_2 . An escapement feature is also provided by connecting the pawl t to the casting t_3 through the intervention of a spring t_4 . In case any obstruction prevents the cylinder from revolving

freely, only the strength of the spring must be overcome when the pawl engages with the ratchet gear as the lower end of the rocker moves in. With this drive, it is necessary to adopt some method of holding the cylinder firmly in position after it has been turned by the pawl. This is accomplished by means of the roller t_5 , which through the action of the spring t_7 , is held firmly against a disk t_4 fastened

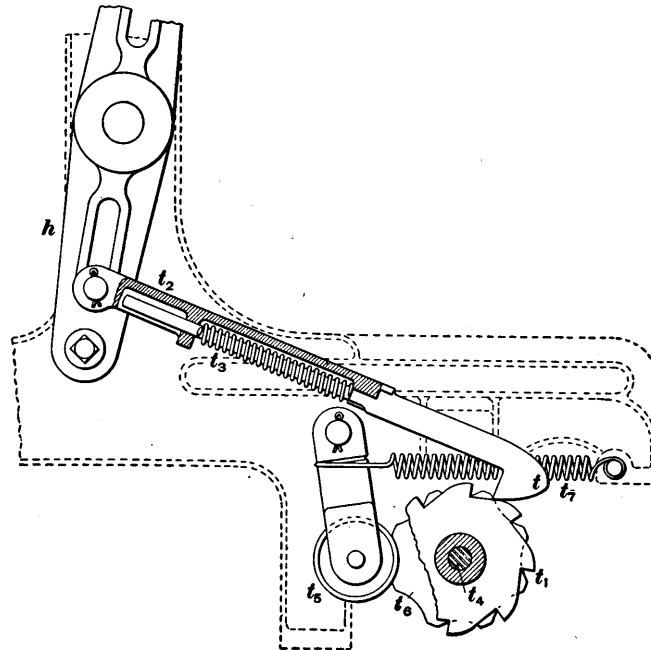

FIG. 15

to the cylinder shaft. This disk has cut-outs in its edge, which, being engaged by the roller, cause the chain cylinder to be securely held in the correct position while the pegs in the bar of the chain raise the fingers of the dobbie. It should be noted that since the lower arm of the rocker moves in only once during every 2 picks, the pawl will turn the chain cylinder only once in 2 picks; consequently, this drive can be adopted only on a double-index dobbie, where one bar of

the pattern chain serves for 2 picks. The index fingers on a doobby with this drive are so shaped that the fingers that are operated by the pegs in the first row will be resting on the pegs in this row when the bar is brought under the fingers by the action of the pawl, and at the same time the fingers operated by the second row of pegs in the same bar will be resting on their pegs.

18. Right-Hand and Left-Hand Dobbies.—It should be noted that the doobby shown in Figs. 5 and 6 is constructed to be placed on a right-hand loom, the doobby being placed at the opposite end from the driving end. Dobbies are spoken of as being **right-hand** or **left-hand**, although there is considerable difference of opinion as to what constitutes a right-hand or a left-hand doobby. Some claim that the mechanism takes its name from the loom on which it is placed, while others claim that a doobby is right-hand or left-hand according to whether it is placed at the right-hand or left-hand side of the loom. As the doobby is placed at the side of the loom opposite that containing the driving pulley, these two opinions are in direct opposition to each other. In this Course, a doobby will be considered right-hand or left-hand according to the position it occupies when attached to the loom.

DOUBLE-CYLINDER DOBBY

CONSTRUCTION

19. If it is desired to weave a pattern that contains a large number of picks in the repeat, a large number of bars must be built for the pattern chain, since even on the double-index doobby one bar represents only 2 picks, and when patterns of several hundred picks are woven this becomes a matter of considerable importance, as a long chain always requires more time in being built. Additional strain is also placed on the doobby by the use of a long chain, since the chain must be supported to a certain extent by the cylinder.

When the pattern consists of but one weave it is difficult to overcome this defect, but it frequently happens that a pattern may consist of two weaves, one of which is repeated a large number of times before the next weave is brought into use. An illustration of this occurs in weaving handkerchiefs, when the center of the handkerchief consists only of a plain weave repeated a sufficient number of times to produce the desired length, another weave is introduced for the border (which may also be repeated) to complete the weave.

To overcome this difficulty, a dobbie known as the **double-**

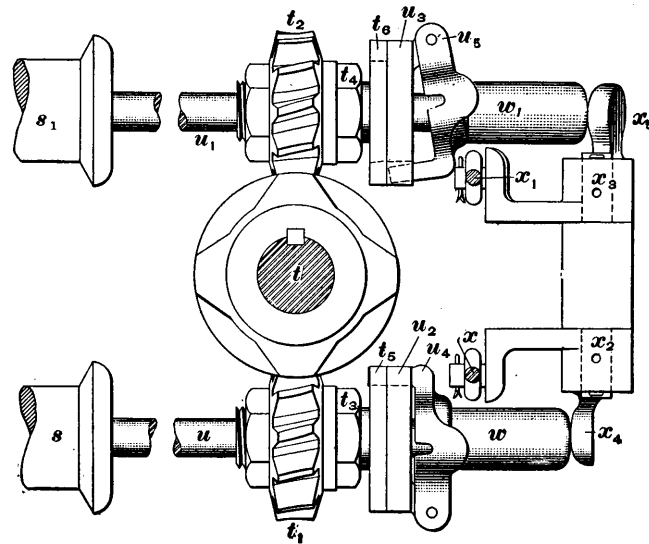

FIG. 16

cylinder dobbie is at present largely used, which (as its name implies) contains two cylinders; the pattern chain for one weave is placed on one of the cylinders, while the pattern chain for the other weave is placed on the other cylinder. Since it is possible to send either cylinder around as many times as there are repeats of the weave before changing on to the other cylinder, it is necessary to build only one repeat of each weave, provided that the number of bars in one repeat is sufficient to encircle the chain cylinder. It

the number of bars required for one repeat of the weave is less than the number of bars required to encircle the chain cylinder, the weave may be repeated as many times as necessary and the chain cylinder sent around a correspondingly less number of times.

Fig. 16 shows a plan view of the driving mechanism for

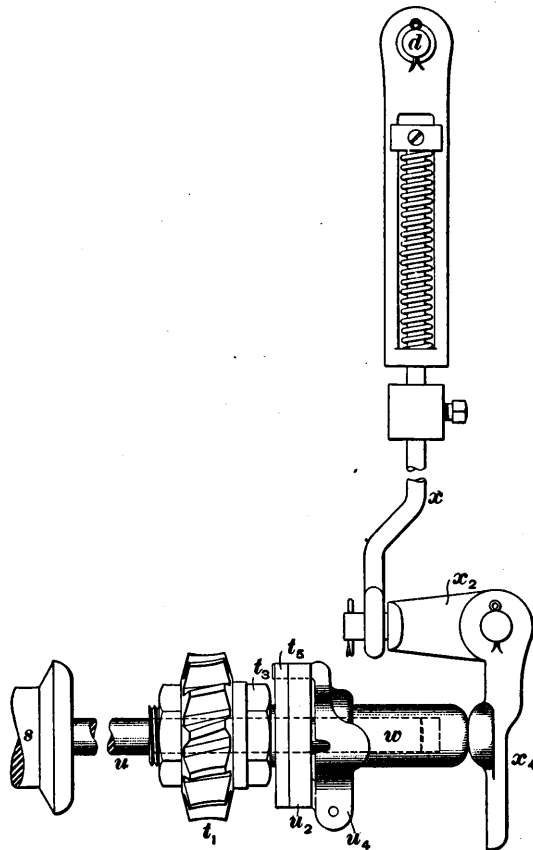

FIG. 17

the cylinders of a two-cylinder dobby, while Fig. 17 shows the driving mechanism of the cylinders as viewed from the end of the loom; one cylinder only is shown in Fig. 17, since the two cylinders are situated one directly behind the other

as viewed from this position. Reference is made to both figures in the following description, the same letters applying to the same parts in both cases.

Directly beneath the dobbie fingers are placed the two cylinders s, s_1 , which receive their motion by means of a worm placed between the cylinders and fixed at the end of an upright shaft t that derives its motion from the crank-shaft of the loom. Working loosely on the cylinder shafts are

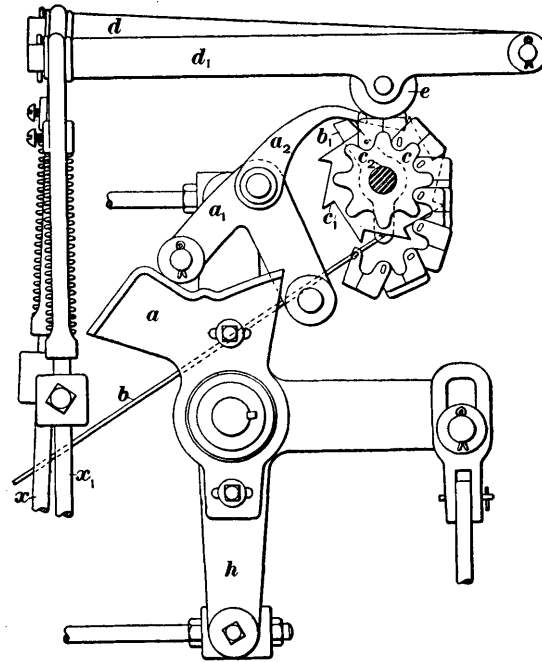

FIG. 18

collars that carry the worm-gears t_1, t_2 and the plates t_s, t_s . The worm-gears are at all times in gear with the worm t ; consequently, these gears, together with the plates t_s, t_s , are revolving as long as the loom is running. Fastened to the cylinder shafts u, u_1 are the plates u_s, u_s , to which are attached the levers u_s, u_s . Between the plates u_s, u_s and the levers u_s, u_s are springs that tend constantly to force the

levers away from their respective plates. Each plate contains a cut-out into which the lever may slide; w, w_1 are two sleeves set loosely on the cylinder shafts and are in contact with the levers u, u_1 . The two rods x, x_1 are worked by levers that are raised and lowered by means of a chain containing *risers* and *sinkers*; x, x_1 are projections of two levers worked by means of the rods x, x_1 .

20. Repeat Motion.—The rods x, x_1 are worked by what is known as the *repeater chain*; a view of it is given in Fig. 18, x, x_1 being the rods shown in Figs. 16 and 17. These rods are attached at their upper ends to the levers d, d_1 , on each of which is placed a roller e that rests on a chain passed around the cylinder c . This chain is made up of links, each of which contains a high and low part; consequently, if the link is placed on the chain in such a manner that its high part will come under the roller e carried by the lever d , this lever will be raised, while the low part of the same link coming under the lever d_1 will allow that lever to drop. If the link is turned end for end so that the high part comes under d_1 while the low part comes under d , the opposite effect will result.

The repeat-chain cylinder c has on its shaft c , a ratchet gear c_1 that is operated by a pawl a , driven by a cam a fastened to the dobbie rocker h . This part of the mechanism operates in such a manner that the pawl a , is thrown forwards each time that the upper part of the dobbie rocker is thrown in; or, in other words, each time that the bottom hooks are drawn out. A dog b_1 that works loosely on the shaft c , is set under the pawl and prevents it from engaging with the teeth of the ratchet except when the dog is lowered by means of the wire b , which is connected at one end to an index finger of the dobbie. When a peg is placed in the pattern chain and lifts this finger, the rod b will be pushed upwards, lowering the dog b , and allowing the pawl a , to drop and engage with the ratchet teeth.

OPERATION

21. The operation of the different mechanisms illustrated in Figs. 16, 17, and 18 is as follows: Suppose that the cylinder s_1 has been in operation and that the cylinder s has been stationary, but that it is now desired to operate the harness chain that is on the cylinder s . Then the cylinder s_1 must be stopped, while the cylinder s must be set in motion. To accomplish this a link that will raise the lever d and allow the lever d_1 to drop is brought under the levers d, d_1 . As the lever d_1 drops, the rod x_1 also drops, releasing the pressure of the lever x_1 on w , and allowing a spring that is constantly exerting a pressure on u_1 to push out this lever until it

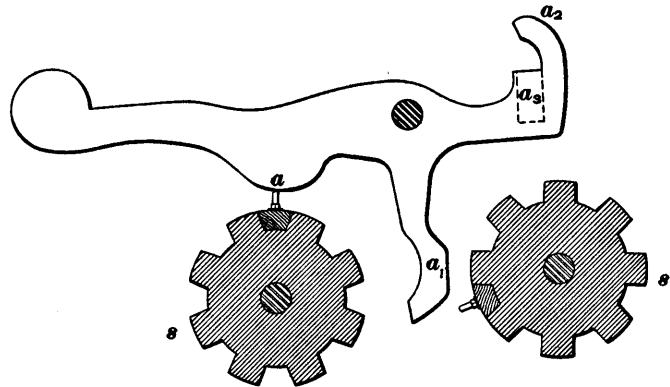

FIG. 19

occupies the position shown in Fig. 16. This action breaks the connection between the plates t_1 and u_1 , and consequently stops the cylinder s_1 , since the worm-gear t_1 and the plate t_1 are on a collar that works loosely on the cylinder shaft. At the same time that the lever d_1 drops, the lever d is raised; this, raising the rod x , throws the lever x_1 , Fig. 17, against the collar w , thus serving to push the lever u_1 through the cut-out in the plate u_1 , into one of the cut-outs in the plate t_1 . This action of the different parts will set the cylinder s in operation, since the two plates u_1, t_1 are securely locked together, and the plate t_1 is receiving motion from the

worm-gear t_1 , while the plate u_2 is fastened to the cylinder shaft. At the time that the lever u_2 is thrown in, a cut-out in the plate t_1 should be directly opposite the cut-out in the plate u_2 . This relative position of the two plates may be secured by loosening the check-nut t_3 , when the plate t_1 may be turned to any desired position. After the plate has been placed in its correct position, the check-nut should be securely fastened.

Fig. 19 shows the kind of finger used on such a dobbie. It is a single-index finger, since it controls both the top and bottom hooks— a_1 working the bottom hook, while a wire resting in the slot a_2 works the top hook. The pegs in the chain passing around the cylinder s , Fig. 16, come under the finger at the point a , Fig. 19, while the pegs in the chain that works on the cylinder s_1 come in contact with the finger at the point a_1 ; thus, if a peg acts on the finger either at the point a or a_1 , its outer end will be raised, while its inner end, and consequently the hooks in connection with it, will be lowered.

22. Suppose that it is desired to weave a pattern containing 200 picks of plain weave and 50 picks of a fancy weave, one repeat of which occupies 10 picks. The number of bars built for each weave must be divisible into the total number of picks for that weave and must also be an even number. Thus, for the weave of 200 picks 10, 20, 40, etc. bars could be built, while for the weave of 50 picks, 10 bars could be used. It will be assumed that 20 bars of the plain weave and 10 bars of the fancy weave are to be built. In addition to the pegs for the weave, there is also placed in the last bar of each chain a peg to operate the index finger connected to the wire rod b , Fig. 18, so that each time the harness chain makes one complete revolution the rod b will be pushed up, thus allowing the pawl a_2 to engage with the teeth of the ratchet and turn the ratchet 1 tooth.

It will be assumed that the 20 bars of plain weave are placed on the cylinder s , and the 10 bars of fancy on s_1 . As it is desired to obtain 200 picks of plain and 50 picks of fancy, the chain containing the plain weave will have

to be sent around ten times, and the 10 bars of fancy will have to be sent around five times. Since the raising of the rod x throws the cylinder s into operation, while the lifting of the rod x_1 throws the cylinder s_1 into operation, the repeat chain to be placed on the cylinder c will contain ten risers that will raise the lever d , and five risers that will raise the lever d_1 , which gives a total of fifteen links in the repeat chain. It should be carefully noted in this connection that a link of the chain for the repeat cylinder contains a riser on one end and a sinker on the other; consequently, when a link is placed on a chain in such a manner that it will raise one lever, it must of necessity lower the other. In the case of this illustration it will be seen that only 30 bars of pattern chain are built, whereas on a single-cylinder, single-index dobby it would have required 250 bars to weave the same pattern; the only additional work required in the case of the double-cylinder dobby is the building of the chain for the repeat cylinder.

BUILDING HARNESS CHAINS FOR DOBBIES

23. The order of lifting and lowering the harnesses is marked on design paper and is known as the *chain draft*, as it is from this draft that the harness chain is made. Fig. 20 shows a harness chain draft for a weave. Each row of squares running vertically represents the order in which 1 harness is raised and lowered, while each row of squares running horizontally shows what harnesses are up on each pick; the bottom horizontal row of squares generally indicates the first pick. The filled-in squares show that a harness is up, while the blank squares show that a harness is down. Thus, by referring to Fig. 20, it will be seen that on the first pick the first, second, third, fourth, fifth, seventh, ninth, and eleventh harnesses are up;

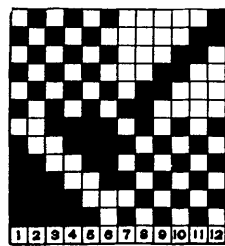

FIG. 20

consequently, the warp ends that are drawn through these harnesses will form the top shed on this pick. It also shows that on this pick the sixth, eighth, tenth, and twelfth harnesses are down; consequently, the ends drawn through these harnesses will form the bottom shed on this pick.

That the method of pegging a pattern chain from a harness draft may be more fully understood, the draft in Fig. 20 will be placed on a harness chain consisting of bars, each of which contains a double row of holes in which pegs may be inserted. A view of such a bar, which is used on a double-index dobby, is shown in Fig. 9 and, as stated, each row of holes represents 1 pick, while the manner of pegging these holes determines the order of lifting the harnesses. If it is desired to raise a lever and, consequently, a harness, a peg is inserted in the hole corresponding to that harness; on the other hand, if it is required that that harness shall be down, the hole is left blank.

24. When building a harness chain, the first thing to determine is the first harness and the first pick, as shown on the draft. It next becomes necessary to peg the pattern chain in such a manner that the bar containing the first pick will be placed on the cylinder first, while the pegs that control the first harness must come at the front of the loom so that the pegs will operate the first lever. When the first harness and the first pick are not designated on the draft, it is safe to assume that the lower left-hand corner will give the position of these two. This is the case with Fig. 20, and consequently the bottom pick, as shown in the harness draft, will be placed on the bar that is first put on the cylinder.

When the pick that is to be pegged first has been determined, it is necessary to determine on which end of the bar the pegs operating the first harness shall be placed. This is governed by the end of the loom on which the dobby is placed, as a chain built for a dobby placed at the right of a loom cannot be put on a dobby placed at the left of the loom. It will be assumed that in this instance the chain is to be

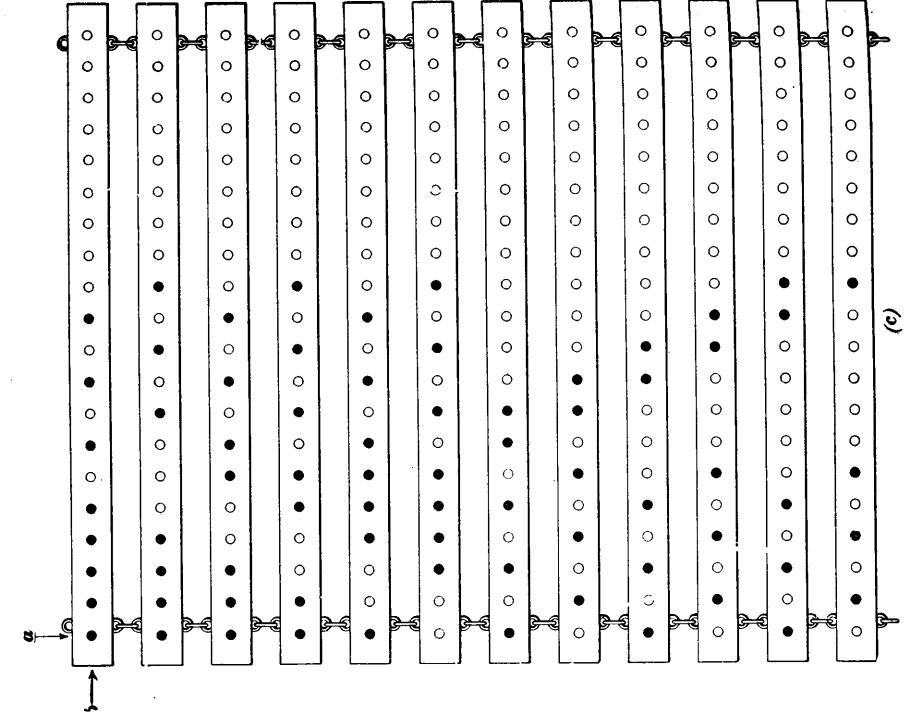
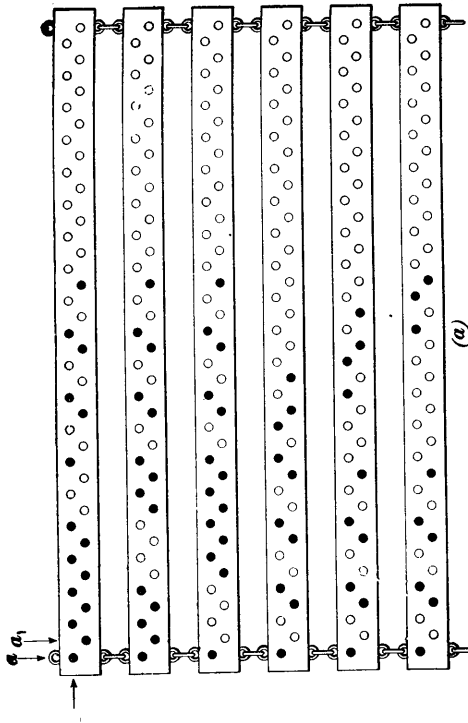
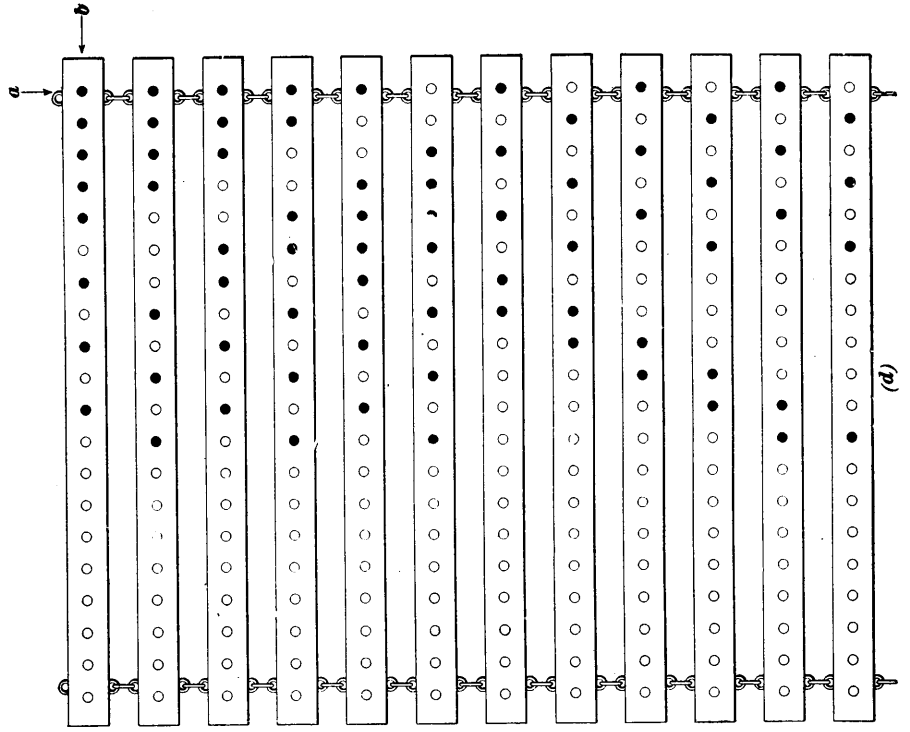
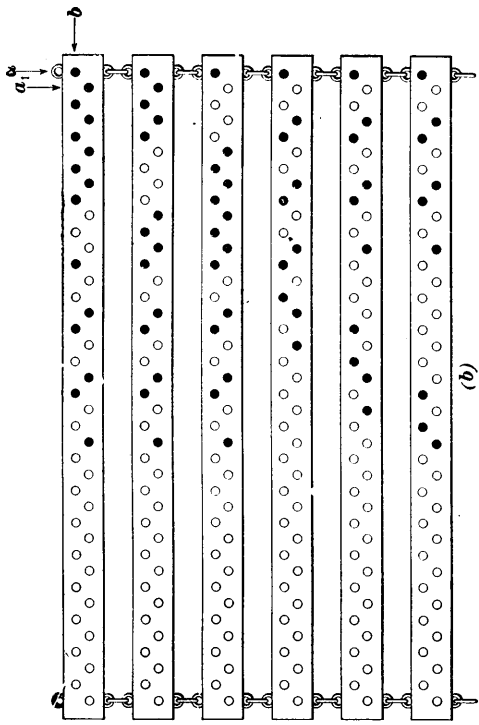

94204

Fig. 21

ILT 8B-1764A

placed on a dobbie on the right of the loom; then the lever that actuates the first harness will be on a person's left when placing the chain on the cylinder and, consequently, the holes on the left-hand end of the chain will govern the first lever. Thus, it is necessary to place the bottom pick of the harness draft on the first row of holes in the chain and also to have the holes on the left of the chain operate the first harness.

Fig. 21 (*a*) represents a harness chain built in this manner; *b* shows the first pick of the weave, while *a*, *a*₁ denote the rows that will operate the first harness. It will be noticed that these bars are made for a 20-harness dobbie, while the weave occupies only 12 harnesses. In such cases the first twelve holes are used and the rest remain blank. In this figure the filled-in circles show where pegs have been inserted.

If the dobbie were placed at the left of the loom, as in Fig. 5, the first row of holes on the right-hand end of the chain would be used for the first harness. A chain pegged for a double-index dobbie placed on the left of the loom is shown in Fig. 21 (*b*), the same draft being used as in Fig. 21 (*a*). In Fig. 21 (*c*) is shown the same weave placed on a chain that would be used on a single-index dobbie placed on the right of the loom. A chain pegged for a single-index dobbie placed on the left of the loom is shown in Fig. 21 (*d*).

FIXING

TIMING AND SETTING THE SINGLE-CYLINDER DOBBY

25. When a loom with a dobbie attached is being started, all the motions connected to the loom proper should be set as on a plain loom before the setting of the dobbie is attempted. Although the setting of this part of a fancy loom may seem to be a difficult problem, in reality, after it has been carefully studied, it will present no very great

obstacle. Each part of the dobbie has an exact setting, which bears a definite relation to some other part of the loom and, if these parts are set in their proper relation to each other, the dobbie will be found to be exact in its action as a whole. The rules for setting that are given here will be found to apply equally well to any dobbie. Later on, references will be made to the setting and timing of the auxiliary motions attached to the dobbie, but it should be borne in mind that the settings here given are fundamental and apply to all cases.

26. Setting the Dobbie Crank-Shaft.—In case the dobbie is driven from the crank-shaft, turn the loom until its crank-shaft is on the bottom center; keeping the loom in this position, move the connecting-rod on the dobbie until the dobbie crank-shaft is on its back center. This can be accomplished by loosening the setscrews that hold the gear on the end of the dobbie crank-shaft. After this has been accomplished, tighten the setscrews. When in this position, the rockers should be perpendicular. Should they not be in this exact position, they may be adjusted by loosening the setnuts at the bottom of the connecting-rod and then moving the rocker until it is in the desired position. When the dobbie is driven from the cam-shaft, place the loom crank-shaft on its bottom center. Have the crank to which the connecting-rod of the dobbie is attached on its back center, and adjust the rockers so that they will be perpendicular when the different parts are in the positions stated.

27. Setting the Knives.—When these adjustments have been made, turn the loom until the bottom knife is at its extreme inward position and then set the knife about $\frac{1}{4}$ inch back of the notches in the hooks; turn the loom over and set the top knife in the same manner. These adjustments may be made by means of the adjustable hooks that connect the knives to the rockers. If the different parts are set in this manner, the top knife will be directly over the bottom knife when the rocker is perpendicular; both

knives will have an equal lift at this point and the harnesses that are changing will consequently be level. Thus, the harnesses that are changing are level when the crank-shaft of the loom is on its bottom center. It should be noted that as an open shed is being dealt with, some of the harnesses will remain up and others down while the rest of the harnesses are changing. Those harnesses, however, that are changing will be level when the loom and the dobbie have been set in the manner described.

28. Setting the Cylinder.—If the cylinder of the dobbie is driven by a worm-gear, this gear should be set so that the cylinder will be brought to a pause when the knives reach the limit of their throws. When in this position, the chain bar should be directly under the fingers, so that the pegs in the bar will be giving the fingers their greatest lift.

On dobbies having two rows of pegs to each bar of the pattern chain, the first row operates the fingers connected to the bottom hooks. Consequently, when setting the cylinder on such a dobbie (the cylinder having the worm-drive), care should be taken to have the bottom knife moving in and the top knife moving out when a new bar of the pattern chain is being forced under the fingers. This will cause the pegs in the first row of the pattern chain to operate when the bottom knife is in and the second row to operate on the next pick, or when the top knife is in. This setting will result in the correct fingers being acted on by the pegs on each pick of the loom.

Another rule for setting the cylinder with the worm-drive and one that applies to either a single- or double-index dobbie is as follows: Have one of the knives as far in as it will move. Loosen the gears that drive the cylinder and turn the cylinder until the pegs operating the hooks for the knife that is in are giving the fingers of the dobbie their full lift. With the cylinder in this position, turn the worm until the straight part, or that portion that gives the pause, is operating on the worm-gear on the end of the cylinder.

Considerable care should be taken to have the chain bar directly under the fingers when the cylinder stops, so that the pegs will lift the fingers and bring down the hooks, causing them to be caught by the knife when it starts on its cutward stroke. The missing of the hooks by the knives will be found to be a common fault in dobbies and therefore should be carefully attended to.

29. Regulating the Shed.—As the same size shed cannot be employed in all cases, several provisions are made by which the doobby may be regulated to give a larger or smaller shed as may be required. The crank on the crank-shaft of the doobby contains a slot in which is fastened the stud to which the connecting-rod is joined. By moving this stud in, or nearer to the crank-shaft, the end of the connecting-rod is brought nearer to the center of the circle that it describes and the throw of the connecting-rod is shortened; but by shortening the throw of the connecting-rod, the throw of the knives and the lift of the harnesses are also shortened, and a smaller shed is produced. By moving this stud out on the crank, or farther from the crank-shaft, the opposite effect will be produced. There is also a slot in the arm of the rocker, to which the connecting-rod is attached by means of a stud. By moving this stud in or out in the slot, the lift of the knives will be lengthened or lessened, respectively.

When the throw of the crank on the doobby has been altered by any of these methods, it will be necessary to reset the knives by adjusting the hooks that connect them with the upright arm of the rocker. These hooks contain setnuts, by means of which the distance of the knives from the upright arm of the rocker may be regulated.

30. Lift of the Harnesses.—The upper parts of the harness levers in all dobbies contain a number of notches, and the harnesses that are attached by the harness straps and wires to the upper notches receive a greater lift than the harnesses connected to the lower notches, since the upper part of the levers will move through a greater space;

consequently, it is the custom to attach the back harnesses to higher notches in order to give them a greater lift.

Special notice should be taken of the device adopted on some dobbies by means of which a greater lift is given to the back harnesses. On these dobbies, the rocker at the back of the dobbie is made somewhat longer than the one at the front, thus giving to that end of the knives a greater throw, and consequently a greater lift to the back harnesses. To accommodate the greater throw of the knives the girts against which the jacks rest are made to slant toward the back, thus allowing the jacks at the back of the dobbie to set farther in toward the loom than those at the front.

31. Skipping.—The fault that is probably most frequently met with in connection with the dobbie is that known as **skipping**; that is, the failure of any one harness to lift when it should, and consequently the filling floating over the ends drawn through that harness when, in reality, the filling should be under those ends. This fault may be caused in several ways. A peg in the pattern chain may become bent in such a manner that, when the bar of the chain in which it is placed comes under the fingers, the peg instead of lifting the finger that it should operate will pass between it and one of the adjacent fingers.

In some cases the cylinder may be moved slightly to one side, thus throwing the pegs out of their proper positions, in which case some of the pegs may not lift their fingers. This fault may be easily remedied by loosening the setscrews that hold the cylinder in place and moving the cylinder until the pegs in the pattern chain come directly under the fingers.

A short peg placed in the pattern chain will sometimes produce skipping, since it will not lift the finger high enough to cause the hook to become engaged with the knife.

If for any cause one of the hooks should become bent, its action is very apt to become uncertain, since it is liable to become bound by the sides of the rack through which it passes. In such a case the hook will not fall when the finger is lifted, and consequently it will not engage with the knife. In other

cases, the hook may just engage with the knife but slip off before the harness has received its full lift and the shuttle has passed through the shed.

In any case where skipping is noticed, the ends that are affected should be traced from the cloth to the harnesses, in order to ascertain through which harness those ends are drawn. Then by carefully watching the fingers and hooks actuating that harness, the cause of the difficulty will generally become apparent.

TIMING AND SETTING THE DOUBLE-CYLINDER DOBBY

32. The cylinders in a double-cylinder dobbie must be stopped and started at just the right instant or mispicks will be made in the cloth; consequently, it is quite necessary that the different parts should be set with great care.

The worm-gear that drives the cylinders should be set in a similar manner to that in the single-cylinder; that is, it should be set so that the cylinder will be brought to a pause when the knives are at the limit of their throws. The cylinders should also be set so that the pegs in the pattern chain will give to the fingers a full lift when the cylinder is on the pause. This will insure the hooks being caught by the knives as they move outwards.

33. Setting the Clutch Gear.—When changing from one cylinder to the other, the clutch lever about to be thrown into connection should be directly opposite one of the cut-outs when the riser on the repeat chain comes in contact with its lever; otherwise, the cylinder will not be turned and no harnesses will be lifted on the first pick. These clutch gears are adjustable and can be set by moving a setnut on the gear so that the open space will be in a correct position to receive the clutch lever when it is thrown. Care should also be taken to have the roller that holds the cylinder securely in position while it is not being turned, so placed that when the cylinder is stopped

by the lever being withdrawn it will be in position to hold the cylinder firmly until it is required again.

34. Setting the Repeat Motion.—One important point should be carefully noted in relation to the double-cylinder dobbie. The pawl that operates the ratchet of the repeat motion is worked by a cam driven by the top part of the upright arm of the rocker; consequently, when the top knife is moving in, a high part in the link on the repeat chain will raise the lever and thus change the cylinder, and on the first pick of the new weave the harnesses will be lifted by the top knife.

The shuttle should be on the shipper side of the loom when a change from one cylinder to the other is being made. The rocker must be set so that the top knife will be moving the hooks and thus raising the harnesses when the loom is picking from the dobbie side; that is, the cylinders should start to change when the shuttle is on the shipper side, but on the first pick of the new weave the shuttle should be picked from the dobbie side.

POWER AND SPEED

35. Since more harnesses are employed when using a dobbie, more power will be required to drive the loom than is the case with the ordinary plain loom. The necessary power will also depend to a certain extent on the number of harnesses being used, but as a general rule it may be stated that where five plain looms are taking 1 horsepower to drive them, the same power will drive only four looms with a dobbie attached.

The speed of a loom with a dobbie attached is less than that of a plain loom, and depends on the number of harnesses used and on the style of weave and character of the yarn. On some weaves it may be necessary to run the loom as low as 140 picks per minute, while on others it is possible to attain a speed of 180 picks. As a rule, when plain looms have dobbies applied, the speed is reduced 10 to 20 per cent.