

## CLOTH ROOMS, PART 1

	<i>Pages</i>
Cloth-Room Processes and Machinery . . . . .	1-39
Introduction . . . . .	1- 6
Cloth Checking . . . . .	7- 8
Sewing and Rolling . . . . .	9-21
Sewing-and-rolling machines; Portable sewing machines; Rolling machines and hand sewing.	
Brushing and Shearing . . . . .	22-39
Shearing-and-Brushing Machines . . . . .	22-33
Rolling head; Brushes; Shear.	
Shear Grinder . . . . .	34
Cotton Brushers . . . . .	34-35
Calender-Rolling Machine . . . . .	36-39

## CLOTH ROOMS, PART 2

	<i>Pages</i>
Trimming-and-Inspecting Machines . . . . .	1-35
Folding and Measuring . . . . .	6-19
Cloth Folder . . . . .	6-18
Automatic drop-center table; Solid, or one-piece, table; Measuring motion.	
Measuring Attachments . . . . .	19
Stamping . . . . .	19-21
Inking arrangement; Stamping machines.	
Preparation for Shipment . . . . .	22-26
Baling; Baling presses; Foreign shipment.	
Shipment in Rolls or Cases . . . . .	27
Cloth Inspection . . . . .	28-32
Ends out; Mispicks; Broken picks; Smashes; Floats; Slubs; Blind end.	
Summary . . . . .	33-35

# CLOTH ROOMS

Serial 500A

(PART 1)

Edition 1

---

## CLOTH-ROOM PROCESSES AND MACHINERY

---

### INTRODUCTION

1. After cotton cloth has been woven and taken from the loom, it is removed to what is known as the **cloth room**, where it passes through certain processes that are necessary or desirable before it is ready to be shipped from the mill to the dry-goods merchant, converting establishment, exporter, clothing factory, or wherever it is intended to be delivered, according to the use to be made of it or the customary method of distribution to the ultimate purchaser. Such shipping of the cloth may take place through the dry-goods commission merchant or through his order; or it may be done directly by the mill, according to the system of selling the goods that is adopted. A complete list of operations that occur in American cotton-mill cloth rooms is somewhat as follows:

1. *Receiving and checking* the cloth from the weave room, for the purpose of verifying the amount received of each style and checking the weave-room report of cloth produced, is required in order to make certain that all the cloth that has been woven or for which the weavers are paid is received in the cloth room, also in order to keep the management informed as to the amount of cloth being received of each style, so

that progress on various orders can be ascertained and arrangements made for shipping.

2. *Inspecting* is for the purpose of examining the cloth received from the weaver, with a view to detecting faults in the fabric and taking suitable action thereon to prevent a repetition of them, and also for the purpose of sorting out the pieces of cloth into first grade, second grade, and in some cases third grade.

3. *Sewing* is the stitching together of the ends of each two consecutive pieces of cloth that are intended to form a continuous length, in order to facilitate some succeeding treatment and to conduct it with the greatest economy.

4. *Rolling* is the process of winding, in a large roll, the continuous sheet of cloth that has been produced by sewing the ends of separate pieces together.

5. *Brushing* is the process of treating the cloth, on one or both sides, with revolving brushes (usually bristle brushes, but sometimes wire brushes followed by bristle brushes), for the purpose of removing loose threads, loose fibers, dust, pieces of leaf, stalk, or other foreign matter, and also imparting a smooth clean surface to the fabric and laying the projecting fibers in one direction.

6. *Scraping and beating* is performed on coarse and heavy fabrics for the purpose of rubbing and striking from the cloth small projecting particles of a fibrous nature (such as knots, lumps, and nubs) that are produced in the processes of manufacture, or those of a foreign nature (such as motes, leaf, and stalk) that come with the raw cotton; these are difficult to remove by means of a mere brushing action.

7. *Shearing* is the operation of cutting from the face, or sometimes from both the face and the back of the fabric, projecting threads and fibers, the presence of which is undesirable in most fabrics.

8. *Calendering* is a compressing and smoothing action produced by passing the fabric between heavy hot or cold rolls to impart a smooth surface to the cloth.

9. *Folding* is the process of arranging the cloth in superimposed layers, each of the same length, so as to provide a

suitable form in which the fabric may be baled for shipment and offered for sale in dry-goods stores, as well as to give a ready means of ascertaining the length in each piece from the number of folds obtained.

10. *Stamping* is the operation of impressing on the outside of a folded piece of cloth such marks as may be required or desired, as for example, the name of the mill, the name of the fabric, the number of yards in the piece, and (especially for export) the trade mark of the manufacturer.

11. *Ticketing* is the operation of attaching to the folded piece of cloth some printed ticket, frequently highly colored or strikingly designed, which may contain the name of the mill, the name of the fabric, the trade mark, the length or width of the goods, and such other features of a like nature as are desirable. Sometimes this is done by means of paper bands passed around the piece of folded cloth and pasted in position; this may be adopted instead of, or in addition to, stamping and ticketing.

12. *Baling* is the packing of a number of pieces of cloth within a covering of burlap, or other material, suitably secured by ropes or iron or steel bands, to prevent the cloth becoming soiled or damaged in transit, and to facilitate transportation by reducing the bulk.

2. In this list only those processes that are usually found in the cloth rooms of American mills are defined. No mention is made of such processes as singeing, bleaching, tinting, starching, tentering, mordanting, dyeing, printing, filling, mercerizing, or associated processes that are necessary in the case of some fabrics to prepare them for the market. Though in a few cases one or more of these processes are conducted in the same establishment as that in which the goods are woven, yet this is the exception rather than the rule, and consequently all such processes are ignored here, since they more properly belong to the operation of a converting, or as it is sometimes called a finishing, establishment.

The expression *finishing* is sometimes applied to the processes that peculiarly belong to the cloth room of a mill, but

it should not be used in this connection, since it is misleading, although there is a precedent for such a use of the term in connection with other industries, as for example in the knitting-goods industry, where finishing means the making up of the knitted fabrics in suitable form for the market, and in the woolen-and-worsted-cloth industry, where the finishing department includes some processes corresponding to those performed in a cotton-cloth room, together with such additional processes as are necessary to prepare the fabric for the market. However, in the cotton trade, it is becoming more and more common for all purely converting processes, which change the appearance of the fabric, to be conducted in a separate establishment, known separately as a bleachery, dye works, print works, or collectively as converting, or finishing, works.

The cloth-room processes listed here have as their object merely the changing of the form of the fabric from that in which it leaves the loom to a suitable one for shipment, and a slight or superficial cleaning of the cloth to make it presentable to the buyer, together with the necessary inspection and baling.

It is in comparatively few cloth rooms that all the processes listed are conducted, since but very few of them are absolutely necessary. The adoption of some or all of the processes depends on: (1) the fabrics that are to be treated; (2) the differences of opinion among millmen as to what is a suitable treatment even for the same fabric, and (3) the policy of the management either in the direction of avoiding all unnecessary processes, for the sake of economy, or of incurring additional expense in the equipment of the mill and in the operation of the cloth room, for the sake of producing the best quality.

3. The equipment and the operation of the cloth room cannot receive too much attention; in too many mills it is given but little consideration. In the designing or the equipment of the mill, very frequently any available space is utilized for the cloth room, while after the mill is in operation,

so long as the goods are inspected and baled, and the room is operated at a minimum expense, it receives no further attention. As a matter of fact, the proper equipment and operation of the cloth room is of vital importance to the successful running of the mill. The construction and location of the cloth room should be of the best, its equipment the most suitable for the fabrics being manufactured, and the arrangement of the machinery such as will enable the cloth to be treated with the least amount of handling and the greatest economy. The machines used should be so selected, set, and operated as to effect an improvement in the cloth between its leaving the loom and being packed into bales, that will far more than compensate for the comparatively small expense per yard involved. This will increase the reputation of the mill for producing well-made, well-classified, and well-finished fabrics, and will result ultimately in increased prices or preference when orders are being placed. Careful and constant attention to this department cannot fail to result in creating in the mind of the wholesale or retail buyer, the commission agent or the converter, those favorable first impressions of the goods that are so desirable, and in preventing the unfavorable impressions that must be produced by badly finished, badly inspected fabrics, made up untidily or irregularly, either in the piece or the bale.

4. In case a mill is sufficiently large to justify the expense, a cloth room should be located independently of the main building, preferably immediately between the weave room and the storehouse for baled goods and on the same level as these. It should be connected both with the weave room and with the storehouse by passages and should be of fireproof construction.

Where the weave room, the cloth room, and the passage between are all on one level, or approximately so, the cloth may be conveyed directly from the former room to the latter by means of trucks running on rails. When the weave room is situated above the cloth room, the cloth may be dropped into the cloth room by means of inclined chutes, while in

case the cloth room is at a higher elevation than the weave room, some mills adopt an endless belt, usually of rubber, that travels at a slow speed and has lags attached at short intervals, to carry the cuts of cloth up to the cloth room. In the case of the storehouse, it is important that the floor should be of such a height above the ground as to afford facilities for loading the bales of goods into railroad cars or on to trucks without raising them, and for this reason it is not always advisable to have the storeroom floor on the same level as the cloth room; but there should not be sufficient difference in the heights of the floors to prevent the bales being trucked from the cloth room to the storeroom on an incline.

One of the most important functions of a cloth room is the inspection of all the cloth manufactured by the mill, so as to ascertain imperfections that necessitate the classification of any pieces as *seconds*. In order that the persons inspecting the cloth may perform their work to the best advantage, the light should be of the best and should come from the best possible direction. It is desirable that this light should come from the roof; a good type is a saw-tooth roof taking the light from the north side, or if this is impracticable, a monitor roof is desirable. In case it is impossible to have either, the cloth room should be so located as to enable the light to be taken from the north side, where the inspection tables should be placed. The artificial light supplied should also be ample and suitable for use when daylight is not available.

The cloth room should be suitably constructed to reduce the risk of fire to a minimum, should be provided with fire-prevention apparatus, be well ventilated, and suitably heated. As many of the machines required are of heavy construction and others have intermittent motions that produce considerable vibration, the floor of the room should be of heavy construction. There should also be below it a well ventilated space, such as a low story or a basement, to provide against dampness in the floor. If this is impossible, the cloth room should be provided with a sufficient number

of slatted platforms on which cloth can be stored above the level of the floor. These platforms are divided by vertical slatted partitions into bins for the storage of different styles of cloth, after they have been folded and examined, until a sufficient number of cuts is collected to form a bale.

The arrangement of the machinery in the cloth room should be such as to reduce to a minimum the distances between the points where the cloth must be handled, always bearing in mind the necessity for adequate light at those tables or machines where inspection takes place.

Cloth rooms should be kept as clean as possible. If the condition of the room, as regards cleanliness, is not carefully considered and if dust and dirt are allowed to collect, it is evident that the objects of a large part of the work will be defeated by a simple matter that could be easily remedied by a little extra care and attention to details. For the purpose of keeping the cloth free from dust and dirt, the dust should be removed from the machines by means of a system of ducts and strong blowers or fans connected to the different machines.

#### CLOTH CHECKING

5. During the process of weaving, the cloth is wound around a roll on the loom until a certain length has been obtained, when it is severed from selvage to selvage and the roll on which it is wound taken out, leaving the cloth in a compactly rolled condition, in which form it is taken to the cloth room. What is known as a **cut** of cotton cloth is that length into which the cloth is finally cut and delivered to the dry-goods store or other ultimate purchaser. The length of a cut is usually about 50 yards, and the completion of each cut is indicated by means of a cut mark placed on the warp. Although the cloth is sometimes removed from the loom when a cut has been completed, it is more common to continue weaving until two cuts have been made; this is known as a *double cut*. In some cases, three, four, or more cuts are woven before the cloth is removed from the loom. The rolls of cloth are usually collected by an operative



detailed for that purpose, piled on a truck, and taken to the cloth room.

Cuts are also often spoken of as *pieces*; for example, it is occasionally found that the daily report of the weave room refers to so many pieces having been delivered to the cloth room. While the use of the word piece in this connection is to some extent justified by custom, it will not be used in this sense here; a piece will be considered as any continuous length of fabric without a seam, and the word *cut* will be used where the length of cloth between the cut marks is meant. The word *bolt* is also sometimes used to indicate a cut of cloth; for example, a bolt of gingham. The term *style* is used to describe a certain kind of cloth as determined by the weave, the weight per yard, the yarns, or any distinctive features in construction.

**6.** Different mills adopt different times for sending the cloth from the weave room to the cloth room, since this of course depends to a great extent on the size of the mill and the number of looms in operation; but it is always best to have a definite time set for this work, as by this means the operators in both rooms who have this in charge can arrange their other work to the best advantage. In the weave room, a record is kept of the number of cuts woven during each day, and if the room is running on more than one style of goods, the different styles are also designated, together with the number of pieces of each style woven. A duplicate of this report is sent to the cloth room, and the first duty of the overseer or second hand of this room when handling any newly arrived lot of cloth is to see that the weave-room report is carefully checked by means of the cloth received. This assures the discovery of any error that may have been made when booking the cloth in the weave room, and also makes it reasonably certain that no piece has been lost while the cloth has been passing from one room to the other. In some mills, it is customary for the list to be sent from the weave room in duplicate and one copy returned to the boss weaver by the overseer of the cloth room, either marked

correct or with any discrepancy between the amount called for by the list and that received in the cloth room indicated. This gives the boss weaver an opportunity of having the error rectified immediately. As different styles of goods are handled differently in the cloth room, and as a favorable opportunity is given, when checking the cloth received, for placing all the pieces that are to be handled alike in a pile by themselves, this should be done then, after which they can readily be taken to the different machines through which they are to pass. It is important that these piles of cloth from the weave room should not be allowed to accumulate, but should be opened, handled, and examined within a reasonable time after they arrive in the cloth room, for they may contain faults that should be discovered and reported to the boss weaver as soon as possible, especially in cases where the faults are those caused by defects in the loom, which should be remedied promptly to prevent the weaving of more cloth that will contain the same fault.

---

## SEWING AND ROLLING

---

### SEWING-AND-ROLLING MACHINES

7. It is more convenient and economical at some of the machines used in a cloth room to handle the cloth in a long continuous sheet, rather than in separate pieces. In some of these machines the cloth follows a path over and under certain brushes, rolls, shears, etc., through which it is difficult to thread the piece of cloth, and if this threading had to take place each time that a cut was run through, much time would be wasted and the production of the machine greatly reduced. Even in machines where the threading of the new piece through the machine would not occupy much time, the frequent stoppages at the ends of the cuts would reduce the production and increase the labor cost. If cuts of cloth 50 yards in length were passed through any of these machines one at a time, the greater part of the attendant's time would be devoted to stopping the machine after one

cut had run through and getting it ready to run another one. It is to avoid this loss of time that it has become customary to stitch the ends of consecutive pieces together and wind a number of them into one large roll, since by this means a much larger number of yards can be run at one time, without having to stop in order to start a new piece. As many of the later machines employed in a cloth room have a capacity of between 25,000 and 35,000 yards of cloth per day, if operated continuously, and as these machines are somewhat expensive to install, it is desirable to have as great a length as possible pass through each machine per day. It is also desirable to avoid any imperfect method of connecting the ends of cloth at the machine in question, which might result in damage to the machine or cloth or both. The sewing machine, therefore, has been introduced, and is widely used in cloth rooms for the purpose of neatly connecting the ends of pieces of cloth by means of a straight row of stitches extending from one side to the other, usually of the style known as a *continuous chain stitch*, and so arranged that the thread may be easily removed after it has served its purpose.

As the ends of the pieces are sewed together, some means must be provided for disposing of the cuts after they are attached to one another; this is generally done by winding them on a roll until a continuous length of as much as 1,000 yards or even more is obtained. The roll is then removed to the next machine through which the cloth is to pass, or in some cases is shipped in the roll to the bleachery or other converting establishment.

8. The two processes of sewing and rolling are generally performed in one machine, which is therefore called a **sewing-and-rolling machine**. Sometimes it is called the *opening-winding-and-sewing machine*, from the fact of its opening the small rolls of cloth that are taken from the loom and rewinding them into larger rolls, as well as sewing the ends together. The construction of the machine is such that after a piece of cloth is wound on the roll, the winding

arrangement is stopped until the end of a second piece is sewed to the end of the first piece, after which the sewing mechanism is stopped and the winding arrangement started

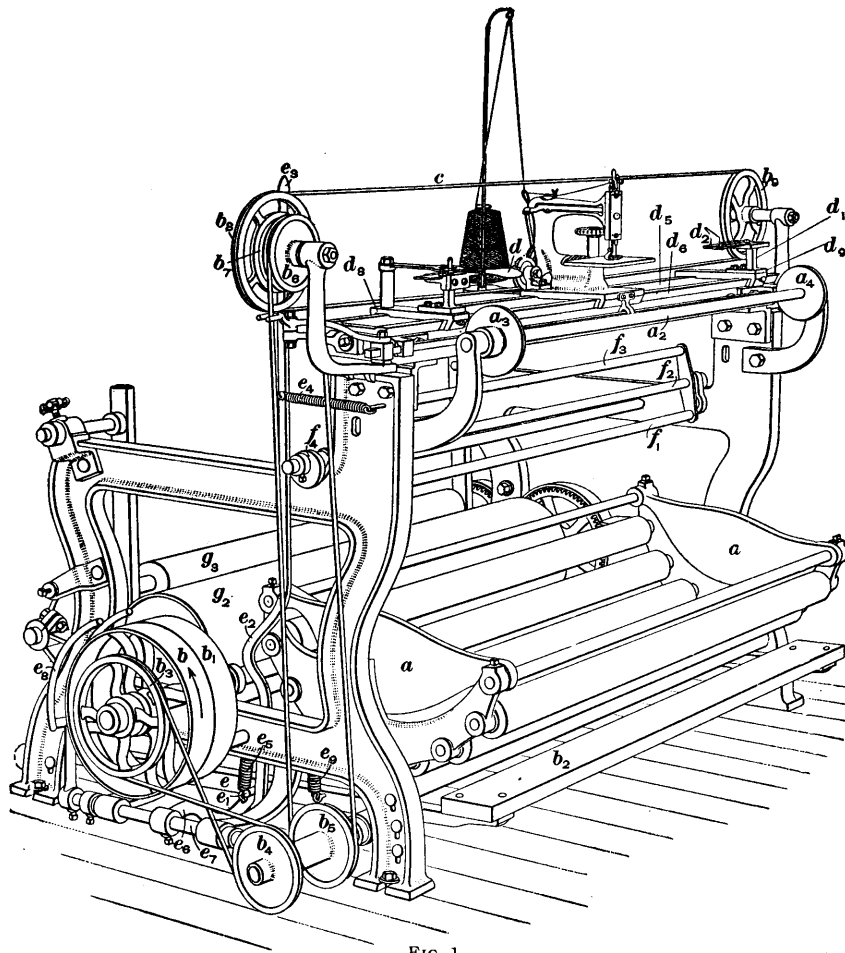

FIG. 1

and continued in action until the second piece is wound on the roll; winding is then discontinued and stitching repeated so as to attach a third piece of cloth to the end of the second, and so on. From the fact that the cloth is held stationary

during stitching, the ends being attached to and distended between steel pins, while the sewing machine travels along a track and inserts the thread that forms the chain stitch, this style of sewing machine is spoken of as the *railway sewing machine*. The seam should occur as near the edge of the piece of cloth as is possible, in order to reduce to a minimum the amount of waste cloth and the extra thickness where the joining occurs; this is desirable so as to offer as little obstruction as possible in passing through succeeding machines. The seam should not be so near the edge, however, that there will be danger of the cloth raveling. From 1 to 2 inches is usually left between the edge of the cloth and the seam, although this distance may be increased.

The sewing-and-rolling machine is almost always used in a cotton cloth room where the cloth has to be brushed, sheared, or calendered afterwards. The cloth passes to the sewing-and-rolling machine immediately after being checked, while still in the roll in which it left the loom, consisting of one, two, or more cuts, all in one piece.

**9. Rolling Mechanism.**—A view of a sewing-and-rolling machine is shown in Fig. 1, while a cross-section through the machine is shown in Fig. 2. The cuts of cloth are placed, one at a time, in the cradle *a* at the front of the machine and the end passed through until it reaches the back of the machine, where it is wound on a wooden roll *g*. The bottom of the cradle consists of wooden rolls, which revolve easily and facilitate the unrolling of the cloth. A cut of cloth is shown at *a*, Fig. 2, and the path that it follows indicated by the full lines. From the cradle, the cloth passes upwards and over the rod *a*, thence over *f*<sub>1</sub>, under *f*<sub>2</sub>, over *f*<sub>3</sub>, under the cylinder *g*, and thence to the roll *g*. In addition to the cylinder *g*, another cylinder *g* is in contact with the cloth that is being wound on the roll *g*. Both these cylinders are covered with sandpaper so as to provide them with a rough surface and enable them to grip the cloth sufficiently to draw it from the cradle *a* through the machine. The rods *a*, *f*<sub>1</sub>, *f*<sub>2</sub>, *f*<sub>3</sub>, not only guide the cloth, but assist in straightening it

out and producing a certain amount of drag to keep it tightly stretched.

The rods  $f_1, f_2, f_3$  also form part of an automatic stop-motion to stop the machine when each piece of cloth has been run through and a new stitching operation is necessary. The cam  $f_4$ , Fig. 1, is on the end of shaft  $f_2$ , on which the

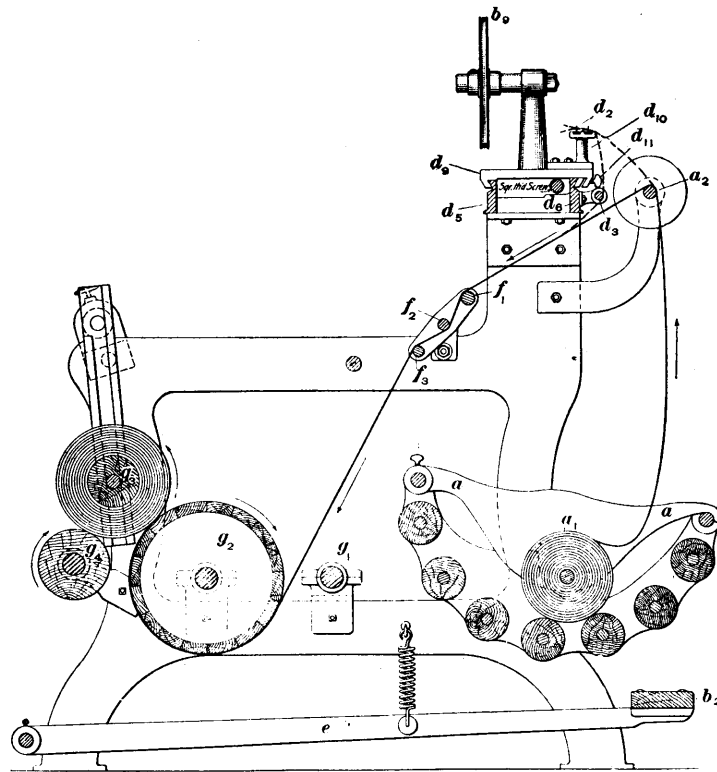

FIG. 2

tension bars  $f_1, f_2$  are held by arms. This shaft rotates freely in its bearings. The tension rods are weighted on one side so that  $f_1$  is heavier than  $f_2$ . Their natural position, which is assumed when there is no tension on the cloth passing through the machine and the last end of the piece is slack, is shown in Fig. 1, where  $f_1$  is at the bottom. The position of

the rods when the cloth is passing through the machine and is subject to tension is shown in Fig. 2, where  $f_1$  has been moved upwards to the right and  $f_2$  depressed to the left. This position is maintained until the *tail-end* of the piece approaches and the tension on the cloth slackens, which allows the rod  $f_1$  to return, thus throwing the cam  $f_3$  on the shaft  $f_2$  against the stop-lever  $e_2$  and, as the latter is moved by the cam, shipping the driving belt from the tight pulley  $b_1$  to the loose pulley  $b$ . At the same time a brake is applied to a brake pulley, on the shaft  $g_1$ , Fig. 2, and the winding mechanism is stopped. The brake and brake pulley are not shown in the views given, but are situated behind the pulley  $b_1$ , Fig. 1. In practice, this device is frequently disconnected, since the operator is generally in constant attendance on the machine and stops the rolling mechanism by means of the stop-lever or the foot-lever  $b_2$  at the bottom.

During the time that the cloth is being wound on the roll  $g$ , at the back of the machine, the cylinders  $g_2, g_3$  receive their motion from a gear on the end of the shaft that carries the tight and loose pulleys  $b_1, b$ , Fig. 1, the belt being on the tight pulley during this operation. The belt is shifted from the loose pulley  $b$  to the tight pulley  $b_1$  by the shipper fork  $e_3$ , which is controlled by a shaft  $e_1$ , to which is setscrewed an arm  $e_4$ , the other end of which is under an arm  $e$  controlled by the foot-lever  $b_2$ . The inner end of  $e_4$  is drawn up against the arm  $e$  by means of a spring  $e_5$ . When it is desired to ship the belt from the loose pulley  $b$  to the tight pulley  $b_1$ , the operator presses down the foot-lever  $b_2$ , which lowers the arm  $e$  together with the inner end of the arm  $e_4$ , turns the shaft  $e_1$ , and throws the shipper fork  $e_3$  in toward the machine, thus moving the belt from the loose pulley  $b$  to the tight pulley  $b_1$ . The arm  $e$  carries a projecting pin  $e_1$  that, when the foot-lever  $b_2$  is pressed down, engages with a notch in the lever  $e_2$  and thus holds the belt on the tight pulley.

In case it is desired to ship the belt from the tight to the loose pulley other than by the automatic device described, the handle  $e_6$  on the lever  $e_2$  is pushed toward the back of the machine, which withdraws the lower end of the lever  $e_2$  from

above the pin  $e$ , and allows the spring  $e_s$  to draw up the arm  $e$ , thus raising the foot-lever  $b_s$ . This allows the arm  $e_s$  to be drawn up at the same time by the spring  $e_s$  that tends to keep the inner end of  $e_s$  pressed up against  $e$ . The lifting of the arm  $e_s$  gives sufficient movement to the shaft  $e_r$  to throw the belt from the tight to the loose pulley. The grooved pulley  $b_s$  is attached to the loose pulley  $b$  and connected by a band to the pulley  $b_s$ , which is on the same sleeve as  $b_s$ , which is connected by a band to the grooved pulley  $b_s$ . Thus, when the driving belt is on the loose pulley  $b$ , the pulley  $b_s$  imparts motion to the pulley  $b_s$ .

**10. Stitching Mechanism.**—When the cut of cloth that is placed in the cradle  $a$  has been entirely unwound, the end is attached to the pins  $d_1$ , Fig. 3,  $d_2$ , Fig. 1, at the ends of the machine; a new cut is then placed in the cradle  $a$  and the end of this cut also fastened to the pins  $d_1, d_2$ . The position of the two ends that are to be stitched together is shown by the dotted lines in Fig. 2.

Preparatory to stitching the two ends of cloth together, the cloth is stretched by means of the handle  $d$ , Figs. 1 and 3. A pin passes through the rod to which this handle is attached and is connected to the slide on which the pins  $d_1$  are secured. After the cloth has been attached to the pins, the handle  $d$  is moved to the left until the arm rests in the notch shown, where it is secured until the stitching operation is completed, when it is raised out of the notch and moved to the right, in order thus to release the cloth. This stretches the cloth while it is being stitched, so that no wrinkles will be formed and also so that when released the cloth will not be narrower at the seam than elsewhere.

**11.** The action of the sewing mechanism is shown in Fig. 3. Just before the stitching action takes place, the driving belt is on the loose pulley and is imparting motion to the pulley  $b_s$  by means of the pulleys  $b_s, b_s, b_s$ , as shown in Fig. 1. When the ends of the cuts have been placed on the pins and are in a suitable position to be stitched, the rod  $d_s$ , Fig. 3, is moved to the left, which throws the leather band from the



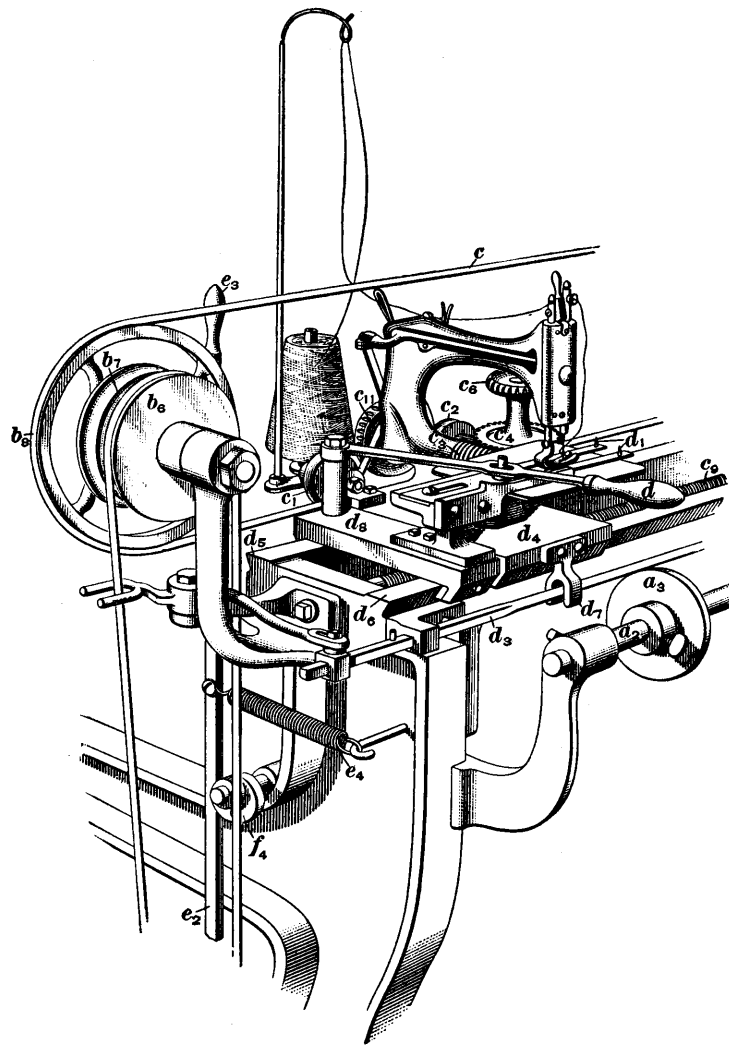

FIG. 3

loose pulley  $b$ , to the tight pulley  $b$ , and imparts motion to the pulley  $b$ , and the band  $c$ . This band passes around the two binder pulleys  $c_1$ ,  $c_2$ , and a pulley  $c_{11}$  on the sewing-machine head, and by this means starts the stitching mechanism in operation.

At the same time, the sewing-machine head travels from one side of the machine to the other. The mechanism that accomplishes this part of the operation is as follows: The

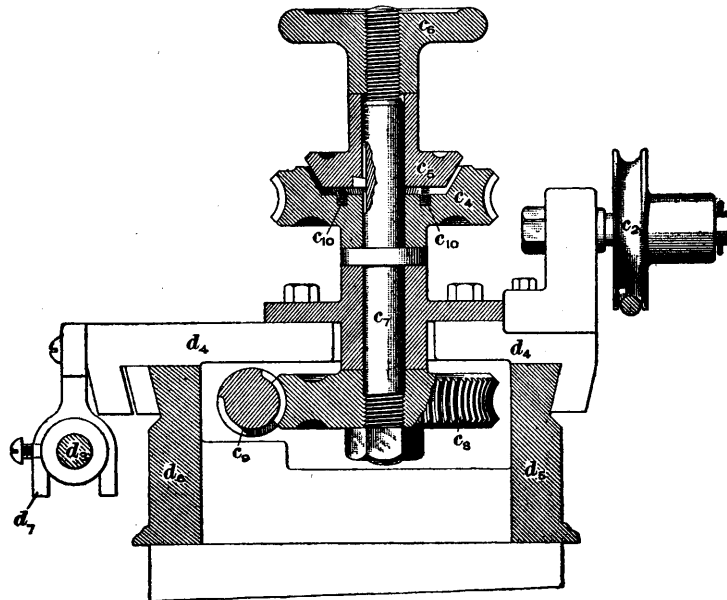

FIG. 4

pulley  $c_{11}$ , Fig. 3, that is attached to the sewing-machine head imparts motion to the worm  $c_3$ , which drives the worm-gear  $c_4$ . The worm-gear  $c_4$ , Fig. 4, forms a friction clutch with the casting  $c_8$ , which carries a key projecting into a keyway in the shaft  $c_7$ . At the upper end of this shaft is a thread on which is a hand wheel  $c_6$ , while at its lower end is a gear  $c_3$ , the teeth of which work in a stationary screw  $c_5$ . Before starting the stitching mechanism the hand wheel  $c_6$  is screwed down, which forces the casting  $c_8$  into contact with

the worm-gear  $c_1$ ; consequently, as the worm  $c_1$ , Fig. 3, imparts motion to the worm-gear  $c_2$ , Fig. 4, the shaft  $c_3$  is rotated, thus giving motion to the gear  $c_4$ . Since the screw  $c_5$  is stationary, the gear  $c_4$ , as it revolves, must necessarily receive a horizontal motion. It is by this means that the sewing-machine head is moved automatically from one side of the machine to the other during the stitching operation.

The plate  $d_1$  on which the sewing-machine head rests, slides on the supports  $d_2$ ,  $d_3$  and carries a projection  $d_4$ , shown in Figs. 3 and 4, which, when the head has traveled the full width of the cloth, comes in contact with a casting setscrewed to the rod  $d_5$ ; this moves the rod  $d_5$  to the right and shifts the band from the tight pulley  $b_1$  to the loose pulley  $b_2$ , thus stopping automatically the stitching mechanism when the seam has been completed. To move the stitching mechanism back to its original position the hand wheel  $c_6$ , Fig. 4, is unscrewed, which allows the springs  $c_7$  to force the casting  $c_8$  out of contact with the worm-gear  $c_4$  and breaks the connection between this gear and the shaft  $c_3$ . When the parts are in this position, the plate  $d_1$ , Fig. 3, together with the different parts of its supports, may be moved by hand to any desired position.

**12.** After the two ends have been stitched, they are removed from the pins  $d_1$ ,  $d_2$  and are allowed to fall between the rods  $a_1$ ,  $d_3$ , Fig. 2. The rolling mechanism is then set in operation by pressing down the foot-lever  $b_3$ , when the second cut of cloth is unrolled and rewound on the roll at the back of the machine. This operation is repeated with a sufficient number of cuts to form one large roll, which should be made large enough to facilitate the operation at the future machines, but not so large that it cannot be readily handled. Rolls are ordinarily made from 28 inches to 32 inches in diameter and contain from 800 yards to 1,200 yards of cloth.

**13.** The plate  $d_1$ , Fig. 3, to which the supports for the handle  $d$ , and the pins  $d_1$  are attached, is setscrewed to the supports  $d_2$ ,  $d_3$ , and does not move during the stitching operation.

The plate  $d_1$  is not attached to the plate  $d_2$ , although in Fig. 3 the latter is shown close to the former, as the sewing machine is there represented in its initial, or starting, position with the presser foot ready to pass between the pins  $d_1$  as the plate  $d_2$  and sewing machine start on their movement to the right. On the other side of the machine is a corresponding plate  $d_3$ , Figs. 1 and 2, carrying a pillar  $d_4$  supporting the pins  $d_5$ . The plate  $d_3$  is capable of sliding on the supports  $d_6$ ,  $d_7$ , but does not move during the stitching operation, being secured to the supports by means of a thumbscrew  $d_{11}$ , Fig. 2.

The guide plates  $a_3$ ,  $a_4$  shown attached to the rod  $a_2$  in Fig. 1, are secured to the rod by thumbscrews in such a position that they serve to guide the cloth correctly while it is being wound on the roll at the back of the machine, and also in suitable relative position to the pins  $d_1$ ,  $d_2$ . It is not customary to change the positions of the plate  $d_3$ , the pins  $d_1$ , and plate  $a_3$  except in extreme cases. When it is desired to make adjustments for different widths of cloth, the thumbscrew  $d_{11}$ , Fig. 2, is loosened and the plate  $d_3$  moved inwards or outwards to bring the pins  $d_5$  into the desired position, after which the thumbscrew is again secured. At the same time the guide plate  $a_4$  attached to the rod  $a_2$ , Fig. 1, is adjusted.

**14.** The sewing-and-rolling machine that has been described occupies a floor space of about 7 feet by 4 feet. The driving pulleys are 12 inches by  $2\frac{1}{2}$  inches, and are usually operated at a speed of 320 revolutions per minute. When operated at its full capacity, it can sew and wind in a day from 500 to 600 cuts, averaging 50 yards in length.

**15.** In some cloth rooms, the sewing machine is independent of the rolling attachment. In case a stationary machine is desired, that portion of the machine shown in the upper part of Fig. 1 is mounted on high stands resting on the floor and is driven by hand or by power as desired. Another arrangement when the sewing attachment is required to be used in connection with some machine,

other than a rolling machine, is to secure the upper portion of the mechanism shown in Fig. 1 to short stands suitable for attachment to any machine desired.

#### PORTABLE SEWING MACHINES

16. In many cases, it is necessary to stitch the ends of two pieces of cloth together in some part of the cloth room where it is more convenient to take the sewing machine to the cloth than to bring the cloth to the machine. This is the case when the stitches that bind the ends of two pieces

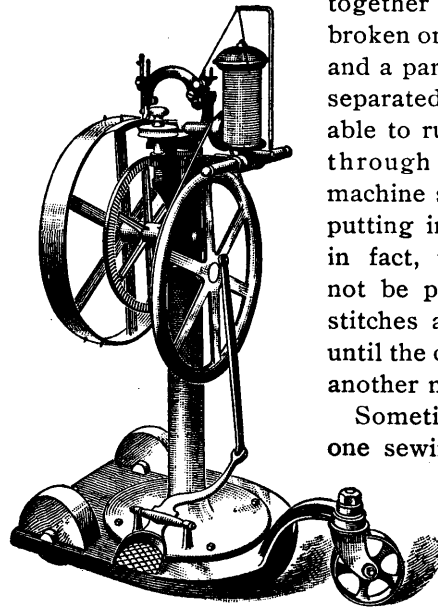

FIG. 5

together in a large roll have been broken or cut, through some cause, and a part at least of the two ends separated. It would be undesirable to run the entire roll of cloth through the sewing-and-rolling machine simply for the purpose of putting in these few stitches, and, in fact, in many cases it would not be possible, as the defective stitches are often not discovered until the cloth is being run through another machine.

Sometimes it is desirable to have one sewing machine available for use with several other machines; for example, when the cloth from a large roll has been run through a later machine and it is de-

sired to attach the end of a new roll to the tail-end of the one that has been run through. In such cases, a portable foot-power sewing machine, shown in Fig. 5, is used. This machine rests on wheels and consequently can be moved readily from one part of the room to another, as may be desired. In operation the ends of the two pieces of cloth

that are to be sewn together are attached by pins to a slowly rotating wheel. As the machine is operated by means of the treadle, this wheel feeds the cloth under the presser foot of the sewing attachment where the stitching is inserted. In other cases where the amount of available floor space is limited, the sewing machine is suspended from the ceiling of the room, and in still other cases where one sewing machine is required at various points in the room, the sewing mechanism is suspended from a track attached to the ceiling, so that it may be moved to different points in the room where it is required. In such cases, of course, the sewing is performed by hand power.

#### ROLLING MACHINES AND HAND SEWING

**17.** Many times, especially in the older cotton mills, machines are used for the same purpose as the sewing-and-rolling machine described, but constructed and operated without the sewing attachment. In general construction, they are similar to the machine shown in Fig. 1, although for special fabrics, such as those exceptionally wide and heavy, different styles of construction are adopted. The mechanism of the machine requires no description beyond that already given. With these machines, the ends of consecutive pieces of cloth are sewed together by hand, the operator using for this purpose a long, heavy needle with thin twine knotted at one end and longer than the width of the fabric. The tail-end of each piece is placed against the new end from another piece and the needle passed alternately through the cloth from one side to the other at intervals of about 2 inches. The knotted end of the twine remains at one edge of the cloth, while the operator ties another knot at the other edge after the thread has been passed through the cloth, so as to prevent its being drawn out in passing on to the roll or through a succeeding machine. This system is largely used in cloth rooms where consecutive pieces of cloth are sewed together temporarily, since it occupies less time and the thread can be easily drawn out later, but is not as satisfactory as machine sewing.

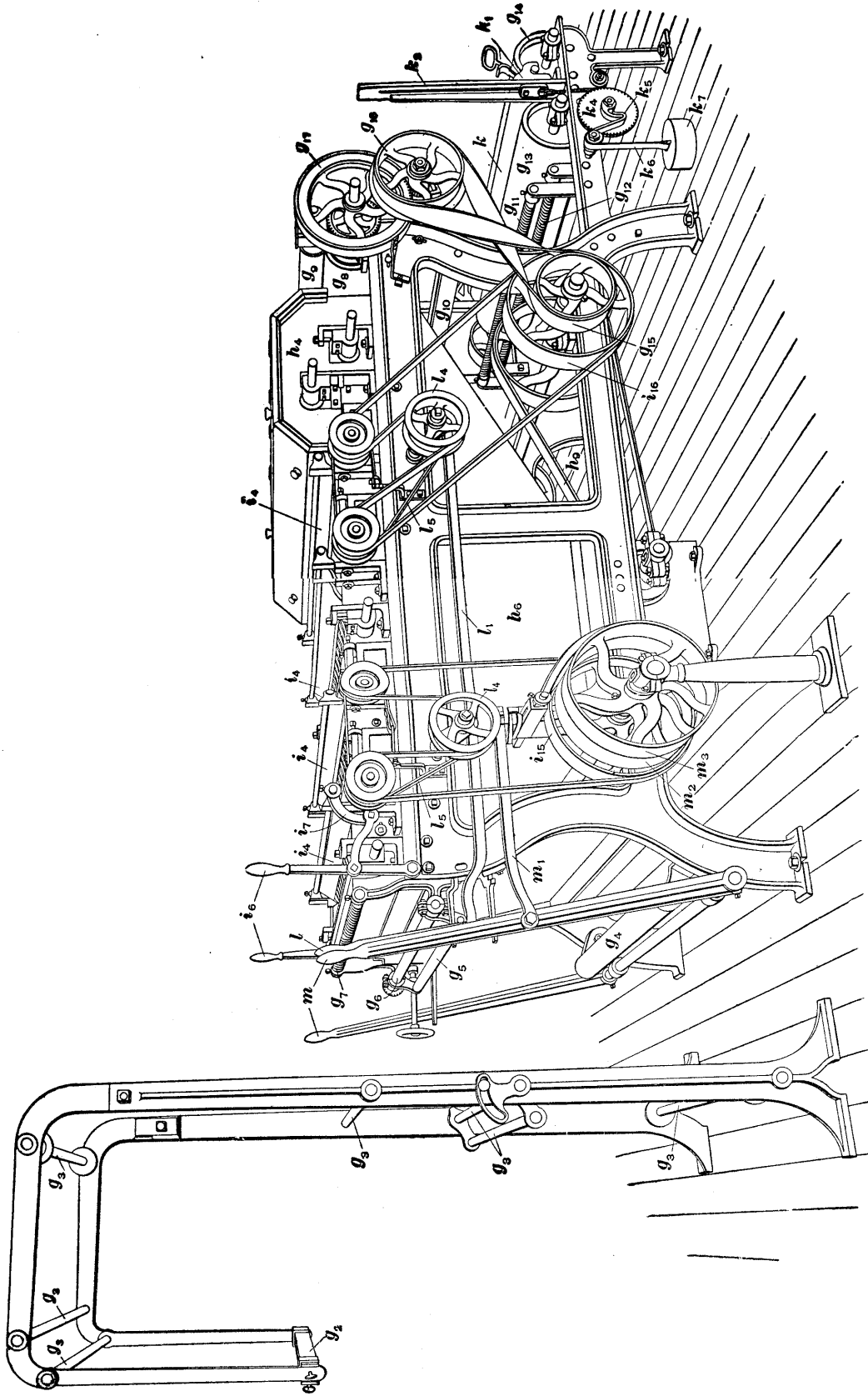

FIG. 6

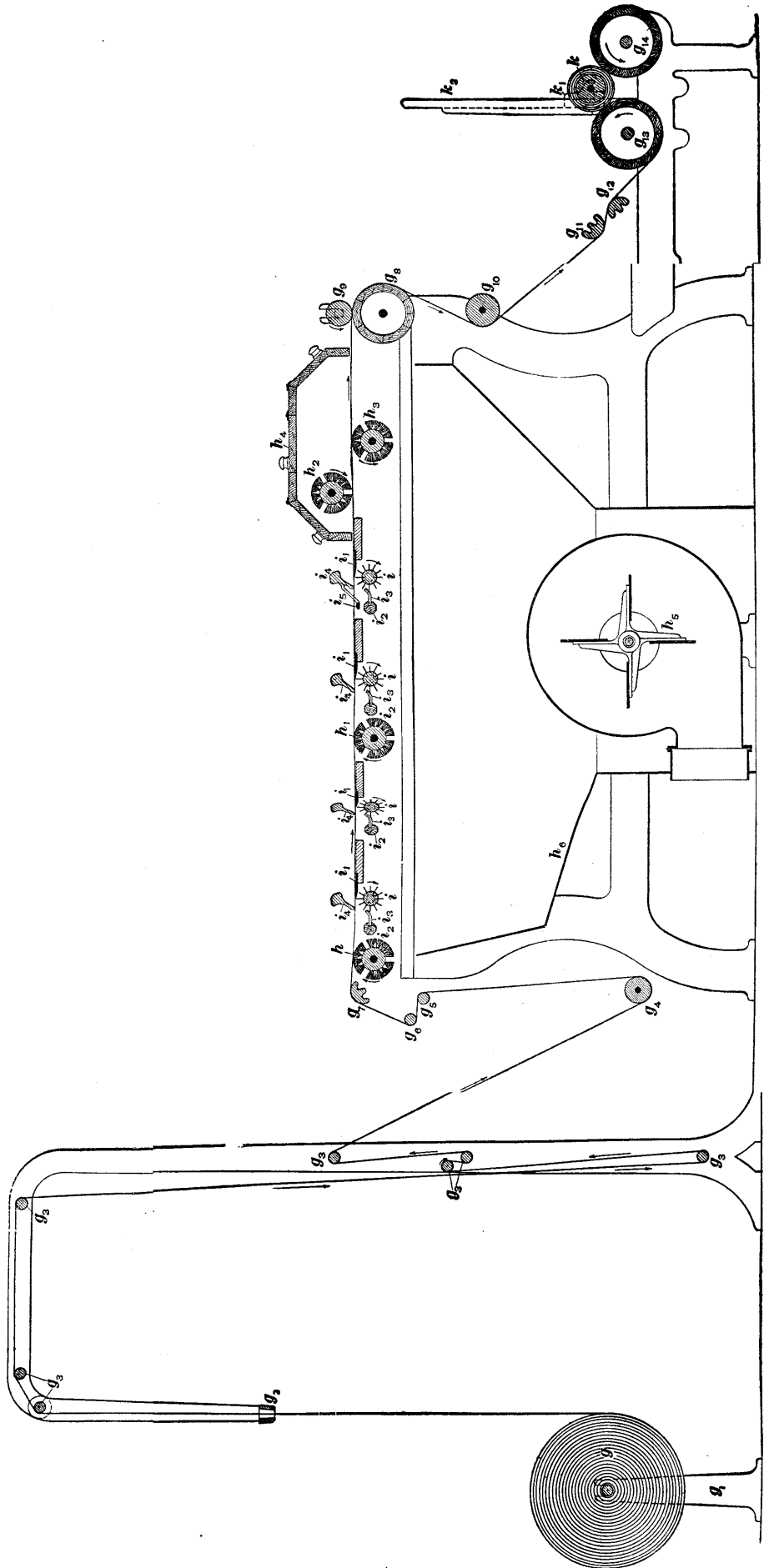

FIG. 7



it, is spread out to its full width and passes into the machine perfectly free from wrinkles. This is accomplished by means of two series of flutes, one series slanting toward one end, and the other toward the other end of the bar, as shown in the illustration, with the result that as the cloth passes over the bar the tendency is to stretch it in its width.

In passing through the machine, the cloth is acted on by four brushes  $h, h_1, h_2, h_3$ , Fig. 7, three of which  $h, h_1, h_2$  operate on the face of the cloth, which is the under side in passing through the machine, and one  $h_3$  on the back of the cloth. Four *revolvers*  $i, i, i, i$ , in conjunction with their respective ledger blades  $i_1, i_1, i_1, i_1$ , shear the projecting fibers from the surface of the cloth. It is customary to have each revolver or each two revolvers preceded by a brush running in the same direction as the cloth, but at a greater speed; the brush thus serves to raise the fiber so that it can be readily cut from the surface of the cloth by the revolver and ledger blade. The brush  $h_3$  that comes in contact with the back of the cloth is simply for the purpose of removing loose threads, dust, bits of leaf, etc. from this side of the fabric. It is enclosed in a hood  $h_4$ , so as to prevent the flyings that it makes from passing into the air of the room in which the machine is placed. The brush  $h_3$  gives a final brushing to the face of the cloth, removing loose ends of yarn and fiber left by shearing and laying down smooth and in one direction those fibers forming a part of the cloth. The brushes  $h_1, h_2$ , which finally brush the fabric, run in the opposite direction to the cloth where they are in contact with it.

The fan, or blower,  $h_5$ , which is enclosed in a casing  $h_6$  so arranged as to enclose all the working parts of the machine, draws away all the flyings, fiber, and foreign matter removed from the cloth and discharges them, through a system of ducts, or flues, outside the mill. The amount of such matter removed in this way is considerable.

After passing through the machine, the cloth emerges between two rolls  $g, g$ , passes around a guide roll  $g_{10}$  under the bar  $g_{11}$ , over the bar  $g_{12}$ , both of which are constructed similar to the bar  $g$ , then under the roll  $g_1$  which

is covered with sandpaper, and finally is wound around the roll  $k$  by the roll  $g_{13}$  and an additional sandpaper-covered roll  $g_{14}$  that form what is known as the *rolling head*. The rolls  $g_8, g_9$  are positively driven and are the means by which the cloth is drawn through the machine, while the rolls  $g_{13}$  and  $g_{14}$ , also positively driven, take the cloth as fast as it is delivered and wind it into a roll.

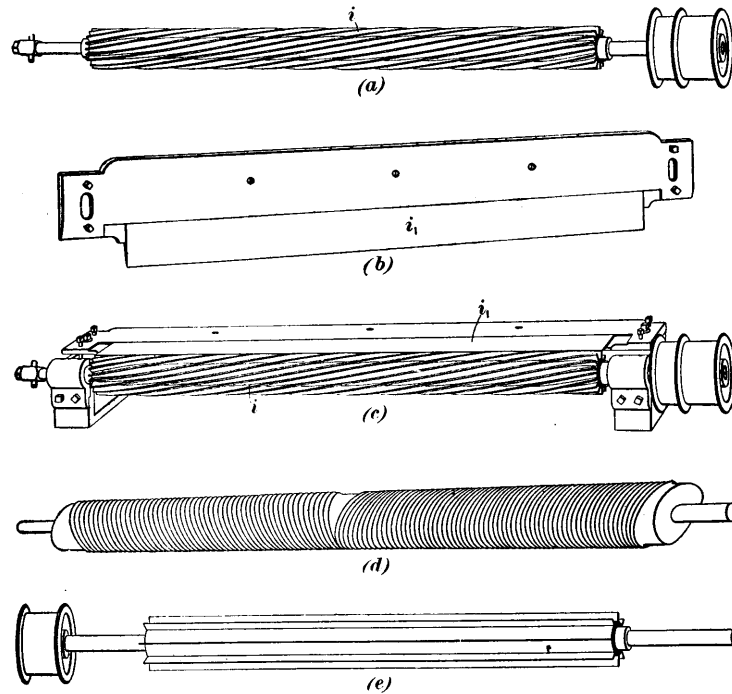

FIG. 8

19. The brushes of this machine are of ordinary construction and consist of a wooden barrel into which short, stiff bristles are inserted. Their only object is to clean the cloth of impurities and raise the fibers so that they may be readily cut by the revolvers and ledger blades.

20. Fig. 8 (a) shows the construction of a **revolver**, while Fig. 8 (b) shows the construction of a **ledger blade**.

The revolver has cutting blades arranged spirally on its surface so that as it revolves the projecting fibers of the cloth will be cut between them and the ledger blade, with which the cloth is in contact, in a manner similar to the action of a pair of scissors. Fig. 8 (c) shows a revolver and a ledger blade as mounted in the machine, with the ledger blade set lightly in contact with the blades of the revolver and its edge directly over the center of the revolver shaft. These parts together are known as a *set of blades*, or sometimes as a *shear*.

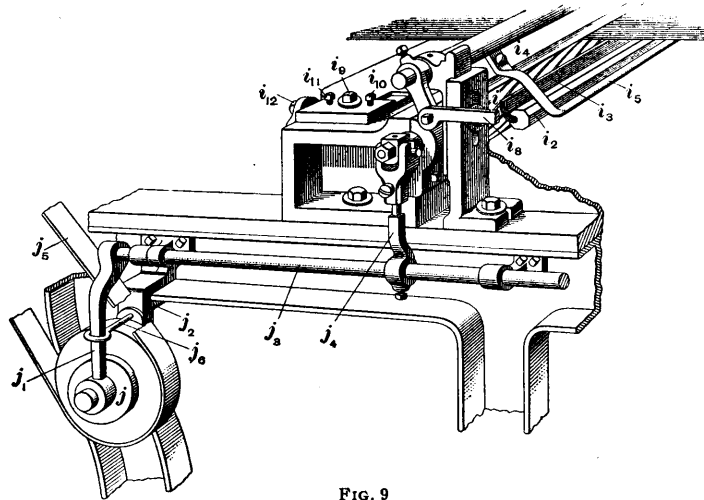

FIG. 9

The revolvers, in addition to having a rotary motion, also have a slight traversing motion, which not only aids them in shearing the cloth, but prevents uneven wear of the revolver or ledger blade. The method of imparting this traverse motion to a revolver is shown in Fig. 9. The revolver is supported at each end by stationary bearings, which hold it in the proper position with relation to the ledger blade, but still allow it to be moved laterally for a certain distance. This lateral, or traversing, movement of the revolver is obtained in the following manner: A rod  $j_1$ , that is supported by brackets attached to the framework carries at one end an

arm  $j_1$  that is operated by a cam  $j$ , being held in contact with the cam by a spring  $j$ , acting through a rod  $j_1$ . As the cam revolves, the lower end of the arm  $j_1$  is caused to move in and out and consequently imparts a rocking motion to the rod  $j_1$ . Attached to the rod is an arm  $j_2$  that carries a forked casting, each arm of which contains a slot. Between the arms of this fork is a small casting that carries two pins, one on each side, that project into the slots in the fork. This latter casting is carried by the shaft of the revolver, and although when moved laterally it imparts the desired traversing motion to the revolver, it does not interfere with the rotation of the latter. Since the rod  $j_1$  receives a rocking motion it imparts a swinging motion to the forked casting, which in turn imparts the traversing motion to the revolver.

As each revolver is connected to the rod  $j_1$  in the same manner, as shown in Fig. 14, a traversing motion is consequently imparted to each revolver.

In order to maintain the necessary contact between the cloth and the ledger blades, cloth rests, or guides,  $i_1$ , Fig. 7, are placed in front of each revolver on the upper side of the cloth. Their function is simply to press down the cloth so that as it passes the shearing point it will be in perfect contact with the ledger blade and thus the fibers will be evenly trimmed. Slotted bars  $i_2$ , having a wick, or oil swab,  $i_3$ , inserted in them are so placed in front of each revolver that the swab rests on the cutting blades. These swabs should be well soaked in oil so that they will lubricate the cutting blades and prevent their *screaming*, which will occur if they are allowed to run dry against the ledger blades.

**21.** When the seams formed by stitching the ends of two cuts of cloth together are passed through the shearing-and-brushing machine it is necessary, in order to prevent cutting the cloth, to raise the cloth guides  $i_1$  so that the brushes  $h, h_1$  will lift the cloth away from the revolvers and ledger blades. Since there is no brush immediately in front of the last revolver, a lifter rod  $i_4$  is attached to the last cloth rest  $i_1$  so as to pass underneath the cloth at this point and

thus serve the same purpose. These guides are raised by means of two handles  $i_6$ , Fig. 6, either of which when operated raises a lever  $i_7$ , attached to the first cloth guide; and as all the other cloth guides are connected by a bar  $i_8$ , as shown in Fig. 14, this raises them all. This is done while the machine is in operation, the handle  $i_6$  being pulled forwards for a short time while the seam is passing through the machine.

The ledger blades may be set to the revolvers as shown in Fig. 10. The blade is bolted to the frame by a bolt  $i_9$ , and may be raised or lowered from the revolver by two adjusting

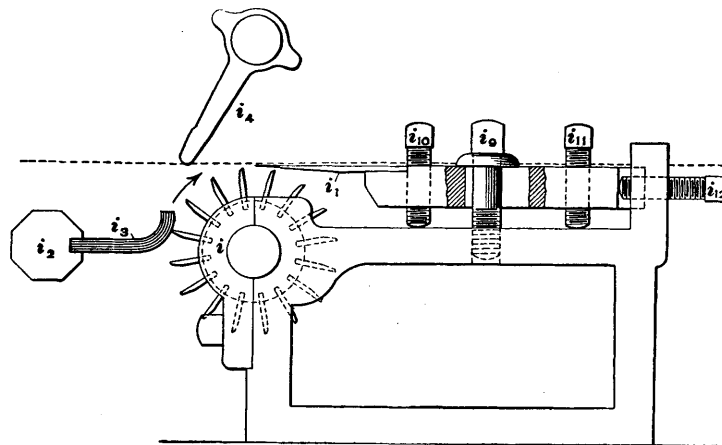

FIG. 10

screws  $i_{10}$ ,  $i_{11}$ ; a screw  $i_{12}$  enables it to be set forwards after it has been ground sufficiently to be shortened slightly. Fig. 10 shows only one end of a ledger blade, but the arrangement is the same for the other end and for all the blades.

Occasionally shears are arranged for the upper side of the cloth; when this is the case the arrangement is as shown in Fig. 11. The ledger blade in this case is adjusted by means of the screws  $i_{10}$ ,  $i_{11}$ ,  $i_{12}$ , and the oil swab  $i_4$  is placed over the revolver. A guard  $i_{13}$  is provided to press the cloth down and away from the revolver and ledger blade when seams are to be passed through the machine. This is

accomplished by the same handle  $i_6$ , Fig. 6, which when operated throws the guard  $i_3$  down under the revolver, as shown by the dotted lines in Fig. 11, and at the same time, by means of the connecting-rod  $i_{14}$ , lowers the cloth guide  $i_4$ , which in this case is placed underneath instead of over the cloth; the position of the cloth guide when it is lowered is also shown by dotted lines, while the corresponding positions of the cloth are shown by the two horizontal dot-and-dash lines.

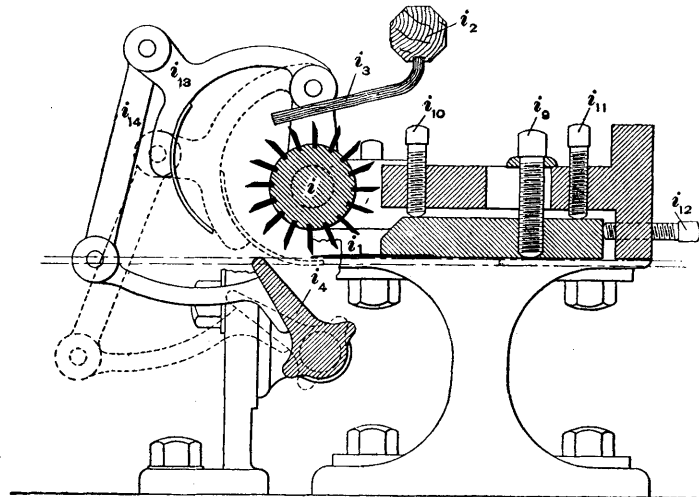

FIG. 11

**22.** In order to be sure that the cloth will not be cut when the seams are being passed through the machine, the driving belts of the revolvers are slackened and a friction is applied to them to check their rotary motion when this takes place. This is accomplished in the following manner: The belts that drive the revolvers pass around binder pulleys  $l_4$ , Fig. 12, that revolve on studs fastened in the castings  $l_2$ , which are pivoted at  $l_5$ . These castings are connected by a rod  $l_1$ , which is connected to a lever  $l$ , and also to friction bands  $l_6$  that pass around brake, or friction, pulleys on the shafts of the revolvers and are attached to brackets  $l_6$ . When the

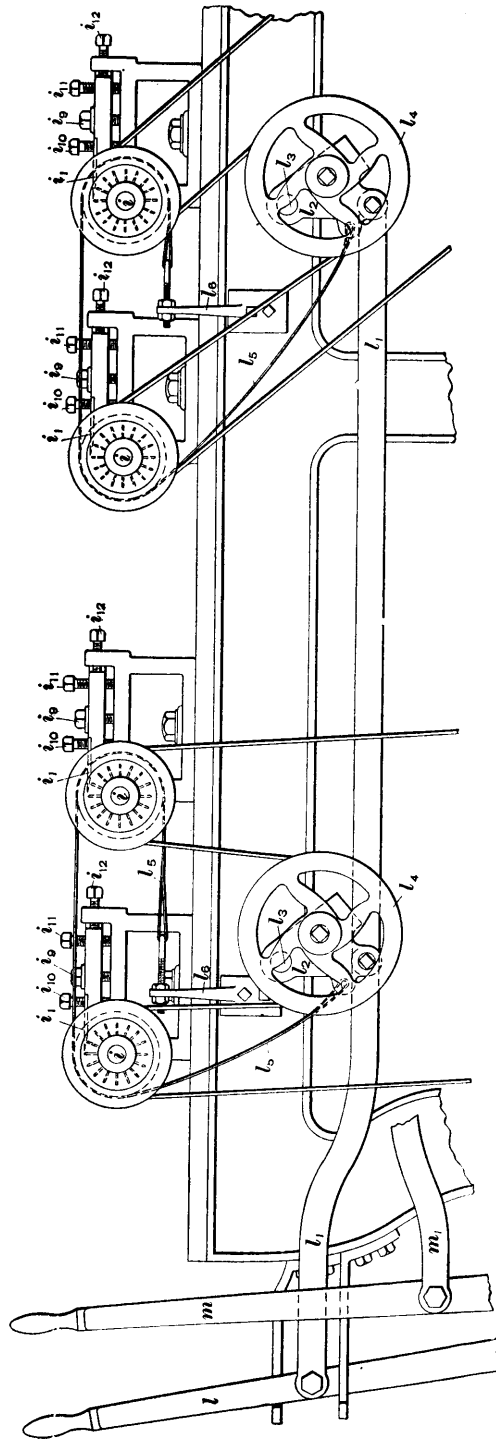

FIG. 12

handle  $l$  is forced forwards, the binder pulleys, in swinging about the center  $l_3$ , slacken the belts, and at the same time the steel friction bands  $l_4$  are tightened and the motion of the revolvers checked.

**23.** The construction of the rolling head is shown in Fig. 13. The cloth in being wound is wrapped about a roll  $k$ , the journals of which are in contact with castings  $k_1$ , that slide in slotted stands  $k_2$ . Motion is imparted to the cloth

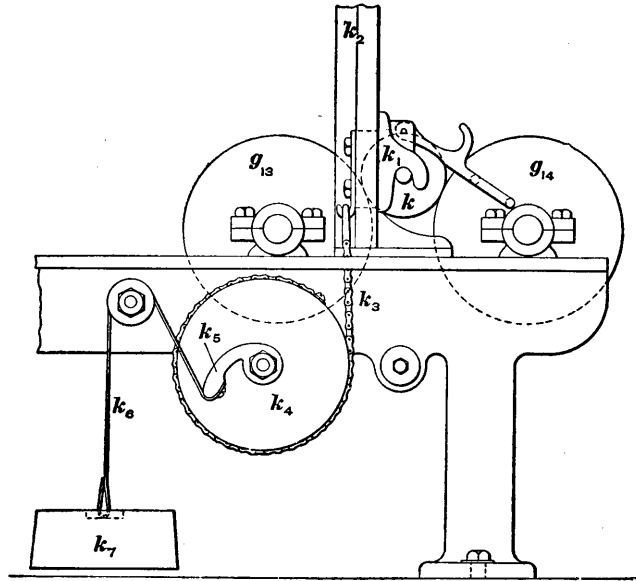

FIG. 13

by two sandpaper-covered rolls  $g_{13}, g_{14}$ . The chain  $k_3$ , attached to the casting  $k_1$ , is wrapped around a disk  $k_4$ , to which its other end is attached. Attached to a projecting wing  $k_5$ , cast in one piece with this disk is a strap  $k_6$  that supports a weight  $k_7$ . As the roll of cloth increases in diameter, the castings  $k_1$  are raised and the chain  $k_3$  imparts motion to the disk, which raises the weight  $k_7$ . As this proceeds, the strap  $k_6$  becomes wrapped around the smaller diameter on the wing  $k_5$ , so that the pressure on the journals of the roll  $k$





on which the cloth is wrapped is decreased correspondingly as the diameter, and consequently the weight, of the roll of cloth increases.

**24.** The driving of the shearing-and-brushing machine is as follows, the references being to Figs. 6 and 14, the former of which shows the belts on one side, and the latter the belts on the other side of the machine: The motion of the machine is primarily controlled by two shipper levers  $m$ , either of which, through the rod  $m_1$ , controls the shipping of the driving belt on the tight and loose pulleys  $m_2, m_3$ . The first two revolvers, as shown in Fig. 6, are driven by a belt from the pulley  $i_{16}$  on the main shaft of the machine. The last two revolvers are driven by a belt from the pulley  $i_{16}$  on a cross-shaft, to which motion is imparted by a belt  $o$ , Fig. 14. On the same shaft is a pulley that by means of a belt  $h_6$  drives the fan, or blower. A pulley  $g_{16}$ , Fig. 6, on this shaft drives, with a cross-belt, a pulley  $g_{16}$ , while a gear compounded with  $g_{16}$  drives a gear  $g_{17}$  that is attached to the shaft of the roll  $g_6$ . The roll  $g_6$  is driven by gears from the shaft of the roll  $g_6$ . On the opposite side of the machine the brushes are driven by belts  $h_7, h_8$ , as shown in Fig. 14. The rolls  $g_{13}, g_{14}$  are driven by a belt  $g_{18}$  from a pulley on the shaft of the roll  $g_6$ . The cam  $j$  is also driven by a belt  $j$  from a pulley on this same shaft.

**25.** The machine represented in Fig. 6 is one of a large number of types of shearing-and-brushing machines. These machines differ very largely in construction:

1. They are made with from one to six sets of shears and from one to three brushes on one side of the cloth, usually the face side, in addition to the two finishing brushes—one on each side of the cloth. The number of shears and brushes on a machine depends on the finish required by a cloth, its condition, the material of which it is made, and the speed at which it is drawn through. Generally speaking, the coarser the cloth, the greater is the number of shears, etc. required, but some kinds of the finest cloth require a large number of shears and brushes. Where there is only

one shearing arrangement on one side of the cloth, there is usually one brush preceding it in addition to the two finishing brushes. Where there are two or more sets of shears on one side of the cloth, one brush precedes each set, or each two sets, of shears.

2. They may be constructed to shear and brush both sides of the cloth at the same time, with one or more sets of shears and brushes operating on the back of the cloth at the same time that others are operating on the face of the cloth, thus shearing and brushing both sides of the fabric by once running it through.

3. Card rolls may be added; these are wooden rolls covered with fillet card clothing, the teeth in which are somewhat straighter than those in ordinary card clothing; the rolls are run with the point of the teeth pointing backwards, in order to prevent forming any nap on the goods. They also are arranged on either one or both sides of the cloth and vary in number. A fuller description of them will be given in connection with the cotton brushing-and-calendering machine.

4. Emery rolls and beaters may be added; these are attached to the feed-end of the machine and are described in connection with the cotton brushing-and-calendering machine.

5. The rolling head may be replaced with a calender-rolling machine, by which the cloth is smoothed and pressed before being wound in a roll. This may be arranged for either cold rolling or hot calendering, with or without a steam moistening arrangement. This mechanism will be described later.

It will thus be seen that the differences in construction, caused by the variable number and arrangement of shears, brushes, and card rolls, and by the use or non-use of emery rolls, beaters, and hot or cold calender rolls, give an almost endless combination of mechanisms, resulting in hundreds of different arrangements of shearing-and-brushing machines; about fifty types are in regular use. The general principles, however, are here described, so that there should be no difficulty in thoroughly understanding the construction

and operation of any of these machines that may be met with in practice. The variable constructions prevent any definite information being given as to the dimensions of shearing-and-brushing machines, but for general guidance it may be stated that these machines vary in length from 8 feet to 12 feet; the width is generally about 7 feet in all machines. About 500 cuts per day is a good average production for a shearing-and-brushing machine.

---

#### SHEAR GRINDER

**26.** When the revolvers or ledger blades of shearing machines become dull, they are sharpened on a **shear grinder**. This is a machine of substantial construction carrying an iron cylinder that has a traverse of about 4 inches, and against which the revolvers or ledger blades are held. The cylinder is kept supplied with fine emery and oil for grinding purposes. When the grinder is used for sharpening the revolvers, they are held in a suitably adjusted stand and driven by chains and sprockets, so as continuously to bring their different parts against the grinding cylinder. When the ledger blades are being ground, a different arrangement of stand is applied to hold the blades in a suitable position, and they are pressed against the grinding roll by levers and weights.

---

#### COTTON BRUSHERS

**27.** The **cotton brusher** performs work similar to that of the shearing-and-brushing machine described, except that it has no shearing operation. It, too, is constructed in many different ways, with a varying number of brushes on each side of the goods, and in combination with other mechanisms for producing various results. Fig. 15 shows a section of one type of this machine that not only comprises a complete brushing machine proper, but also includes emery rolls, beaters, and card rolls, as well as a calender-rolling attachment. The framework *a* of the main machine rests on the floor of the room and is arranged with a level horizontal

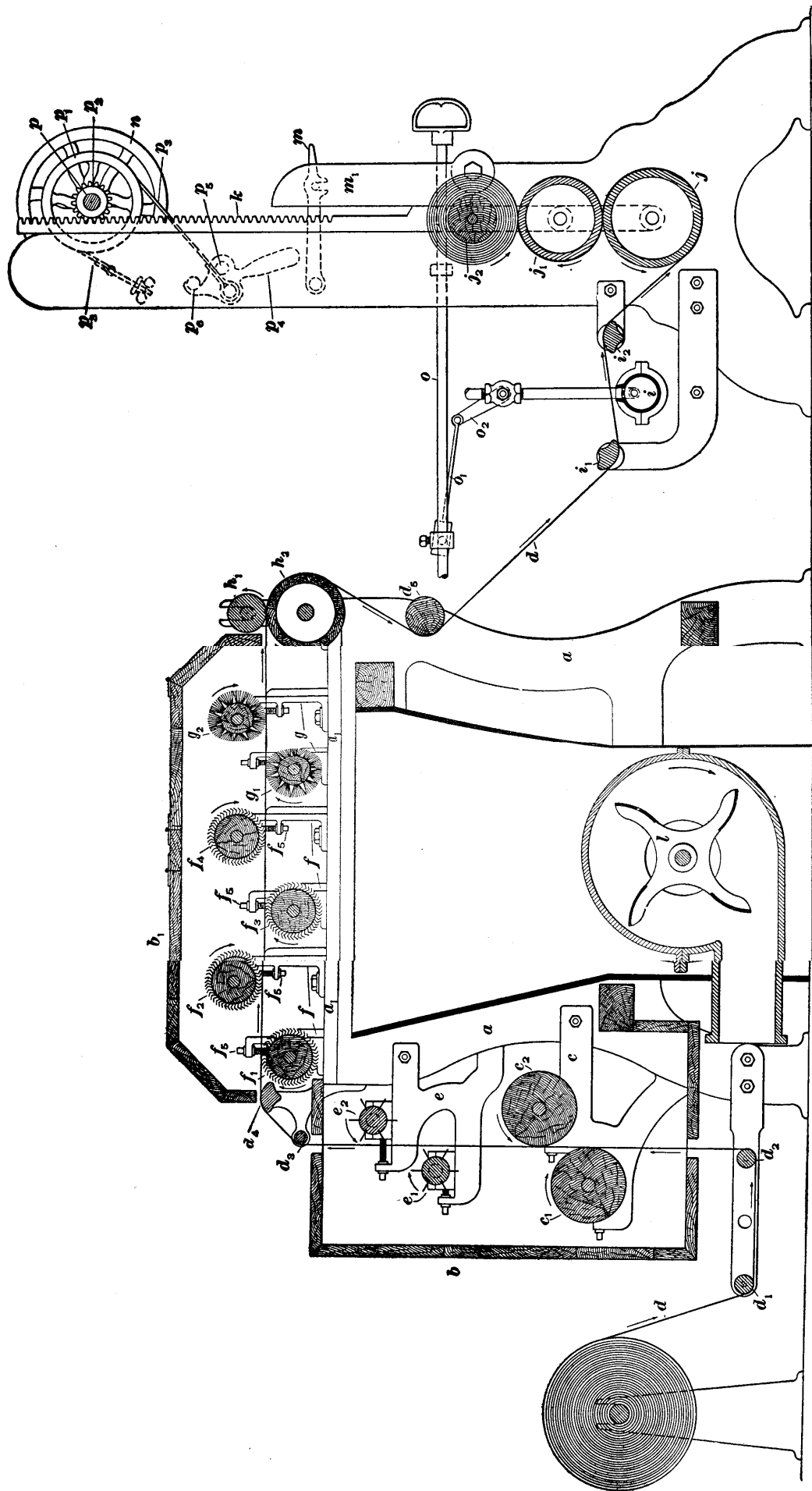

FIG. 15

surface at the upper part  $a_1$ , on which rest brackets carrying the brushes, card rolls, and the rolls that draw the cloth through the machine. At the feed-end of the machine is attached a bracket  $c$  carrying in suitable adjustable bearings the emery rolls  $c_1, c_2$ , so arranged that one operates on the face of the cloth and the other on the back. Each emery roll consists of a wooden barrel covered spirally with a fillet of emery cloth secured at each end, or in some cases with a coating of coarse emery glued on to the surface of the roll.

**28.** The cloth  $d$  passes through the machine in the direction shown by the arrows, first under the guide rolls  $d_1, d_2$ , thence upwards and between the two emery rolls. These rolls revolve in the opposite direction to that in which the cloth is passing, and have a scraping action, which for the most part removes motes, leaf, and rough places projecting on each side of the fabric, those that are not removed being sufficiently loosened to facilitate their removal by the beaters, card rolls, or brushes of the machine. The beaters  $e_1, e_2$  are supported in adjustable bearings on a bracket  $e$  so that one operates on the face of the fabric and the other on the back. Fig. 8 ( $e$ ) represents one of these beaters removed from the machine. It has steel blades radiating from the barrel and set equal distances apart, each side of the edge of the blade forming a sharp corner. These beaters run in the opposite direction to that in which the cloth passes, and knock off the knots and nubs that in many cases cannot be removed by any other means, as well as loosen the dust and dirt so that it may be brushed off by the card rolls and bristle brushes.

The cloth continues its passage over a guide roll  $d_3$  and guide bar  $d_4$  and next comes under the action of four card rolls  $f_1, f_2, f_3, f_4$  supported from the framework by brackets  $l$  and adjustable by means of the setscrews  $f_5$ . The card rolls  $f_1, f_2$  operate on the under side of the cloth and  $f_3, f_4$  on the upper side. These rolls are covered with card fillet and run in the opposite direction to that in which the teeth point, thus avoiding the formation of a nap on the

cloth, but serving to remove motes, specks, etc. After passing between these rolls, the cloth is subjected to the action of two bristle brushes  $g_1, g_2$  mounted in adjustable bearings on brackets  $g$  that are set on the horizontal surfaces of the framework of the machine. These brushes are set with stiff bristles and correspond in their construction and operation to  $h_1, h_2$ , Fig. 7. The cloth then passes between the rolls  $h_1, h_2$ , which draw it through the machine. These rolls, in construction and operation, correspond to those shown at  $g_1, g_2$ , in Fig. 7, and are described in connection with the machine there illustrated.

29. The emery rolls and beaters are incased by the removable cover  $b$ , while the brushes and card rolls are covered by the upper cover  $b_1$ . Both of these covers are so constructed as to admit of their being partly removed, thus affording facilities for inspecting and cleaning the machine. An exhaust fan  $l$  is provided, which removes from the incased portion most of the lint, dust, and smaller particles of fibrous or foreign matter, delivering them into a flue or chamber arranged to receive them. The threads in many cases remain on the surface of the brushes or slightly embedded between the bristles and have to be removed at intervals—several times each day.

---

#### CALENDER-ROLLING MACHINE

30. The machine shown in Fig. 15 also differs from that shown in Fig. 6 in the treatment of the cloth after it leaves the machine proper. In the machine shown in Figs. 6 and 7, the cloth was simply rolled at a rolling head, but in the case of the machine shown in Fig. 15, an entirely separate mechanism is placed in front of the machine, known as a **calender-rolling machine**, the object of which is not only to form the cloth into a roll, but before doing so to pass it between heavy rolls for the purpose of smoothing out the goods. The cloth passes from the brusher under and partly around a guide roll  $d_1$ , thence under a guide bar  $i_1$  and over a second guide bar  $i_2$ , beneath which is placed

a hollow steam vapor cylinder  $i$ . This is connected to a steam pipe, and by means of perforations on its upper side allows a light vapor of steam to impinge on the cloth as it passes between the two guides  $i_1, i_2$ ; the flow of steam is very small and can be regulated as desired. The fabrics only require to be moistened sufficiently to aid the heavy calender rolls in smoothing out the cloth and to give it a softer finish and feel. The steam is admitted to the vapor cylinder through a cut-off valve so arranged that it shuts off the supply of steam entirely when the machine is stopped, thus preventing any excessively damp places in the fabrics. This is accomplished by connecting the lever  $o$ , that operates the valve to the shipper rod  $o$  by a rod  $o_1$ ; thus, as the shipper rod is operated to stop the machine, the steam is automatically cut off from the vapor cylinder  $i$ ; when the machine is started again the steam is admitted to it without further attention on the part of the operator.

**31.** After leaving the guide  $i$ , the cloth passes under and partly around the lower calender roll  $j$  and upwards and partly around the upper calender roll  $j_1$ , thence to the cloth roll  $j_2$ , around which it is wound. In passing between the rolls  $j, j_1$ , the cloth is subjected to a certain amount of pressure, since both rolls are of considerable weight, thus calendering or compressing the fabric and producing a smooth surface. These rolls may be driven at the same surface speed, in which case they have merely a compressive action; or, by the use of unequally sized gears, the upper roll may be driven slightly faster than the lower one, thus producing an ironing effect on the fabric and increasing the smoothing action of the rolls. The rolls  $j, j_1$  are hollow and fitted with stuffing-boxes, piping, and valves, so that steam may be admitted to the inside of both rolls in order to have them hot while the cloth is passing through; or in case it is desired that the fabric be cold rolled, the steam may be shut off and the fabric calendered without heat. In some cases where it is never desired to use the machine with hot rolls, smaller calender rolls are used without any arrangement for heating them.



**32.** At each side of the calender-rolling arrangement is a long rack, similar to  $k$ , Fig. 15, that rests on one of the journals of the wooden roll on which the cloth is wound. A gear  $p_2$  on a cross-shaft  $p$  extending across the calender-rolling arrangement engages with the rack  $k$ , a similar gear engaging with the rack on the opposite side, which is not shown in Fig. 15. Attached to this shaft is a friction pulley  $p_1$ , around which passes a friction strap  $p_3$  that is connected to a lever  $p_4$ . This lever is pivoted at  $p_5$  and so arranged that by raising it the friction can be immediately released, or by lowering it, as shown in Fig. 15, the friction can be applied to the friction pulley. When in the position shown, the lever  $p_4$  is held securely in place by means of a pin  $p_6$  that engages its hooked upper part. By means of this friction arrangement the racks place a considerable amount of pressure on the cloth as it is wound, so that a smooth, hard, and even roll of goods is produced. This pressure may be easily regulated by increasing or decreasing the amount of friction that the strap  $p_3$  places on the friction pulley  $p_1$ .

When a sufficient length of cloth has been wound around the cloth roll, it is removed by unhooking the latches  $m$  and swinging out the standards  $m_1$ , which are on each side of the calender-rolling head and pivoted on a pin at the lower part. These standards are lowered and the lever  $p_4$  raised, while by means of the hand wheel  $n$ , the racks are raised so as to relieve the pressure on the cloth roll, which is then removed from the machine and a new one inserted.

It is found, in practice, that by calendering the cloth in this way, especially in the case of hot calendering and where the upper roll is run faster than the lower one, there is a gain in length. This varies from  $1\frac{1}{2}$  to 5 per cent. and can be arranged to be still greater than this; but it is not desirable to stretch the goods too much, nor is there any ultimate advantage in doing so, since a certain length of the cloth has to be of a given weight, and the goods have to be made correspondingly heavier at the loom to offset the stretch.

**33.** After the roll of cloth has been formed and removed from the machine, it is customary to allow it to stand several hours or over night, after which the result of the steaming, calendering, and remaining under pressure for a considerable period is found to have imparted a very smooth appearance and feel to the fabric.

**34.** A cotton brushing machine with the attachments described occupies a floor space of about 10 feet by 7 feet and carries  $14'' \times 3\frac{1}{2}''$  tight and loose pulleys on a shaft revolving at a speed of about 400 revolutions per minute. Most of the belts connecting the various parts of the machine are 2 inches in width.

# CLOTH ROOMS

(PART 2)

Serial 500B

Edition 1

---

## TRIMMING-AND-INSPECTING MACHINES

1. In many mills where the cloth manufactured does not require shearing, heavy brushing, or calendering, or is not of sufficient strength or suitable construction to withstand the strain of such processes, the shearing-and-brushing machines of the types previously described are not used; this also renders the use of sewing-and-rolling machines unnecessary. In place of these machines one known as the **trimming-and-inspecting machine**, sometimes called a *cloth trimmer*, or a *brushing-and-inspecting machine*, is adopted. The object of this machine is to give a slight brushing to one or both sides of the fabric, thus removing loose threads, lint, dust, etc., and at the same time to afford a ready and rapid means of inspecting the cloth, if so desired. The machine is usually constructed to take the cloth in short pieces just as they are taken from the loom, although in some few cases it is made to take a roll from the sewing-and-rolling machine. It is also sometimes built without a brushing arrangement, in which case it becomes merely an inspecting machine.

A view of a common type of cloth trimmer is given in Fig. 1, while a section through the machine is shown in Fig. 2. This machine is built for both brushing and inspecting and is constructed to receive only one piece, usually either a single or a double cut, so that the cloth is not passed through the sewing-and-rolling machine before coming to this machine. The piece of cloth *n*, Fig. 2, is placed in the cradle *n*, and the end passed over the roll *n*, partly around

the roll  $n_3$ , and then to the roll  $n_4$ , from which it passes into the machine. The cloth then passes partly around the roll  $n_5$ , after which it comes in contact with the brushes  $n_6$ ,  $n_7$ , which may be arranged according to several methods. In some cases only one brush is used, which brushes the face of the cloth, while in other cases two brushes are used, both coming

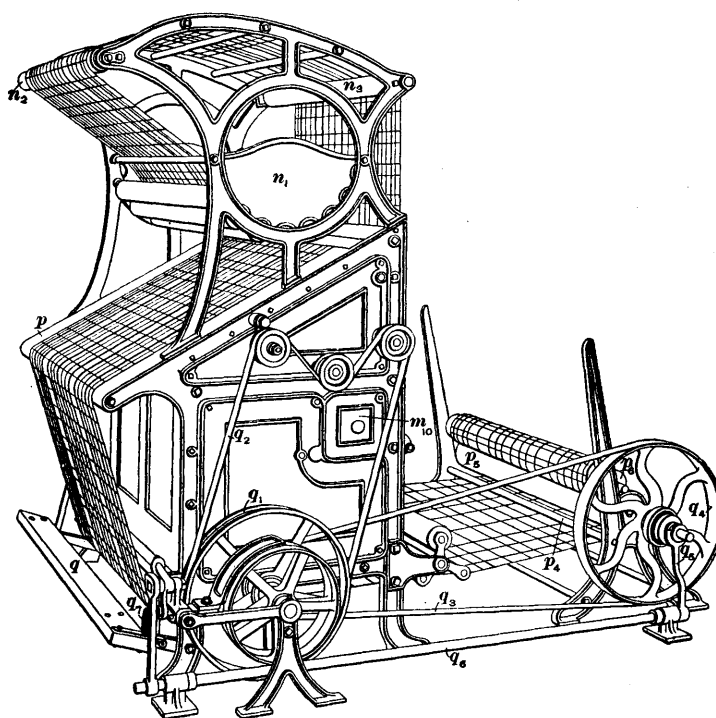

FIG. 1

in contact with one side of the goods; in still other cases the brushes are arranged as shown in Fig. 2. The brushes revolve in the opposite direction to that in which the cloth passes. From them, the cloth passes partly around the roll  $n_8$ , and is then lightly brushed by the brush  $n_9$ , after which it passes on to the inspecting table  $p$ , which is painted black. As the cloth passes over this table the attendant

closely inspects it. In case any defect is noticed, the machine is stopped and the defect marked either by passing a short piece of colored thread through the selvage of the cloth, so as to call attention to it later, or, if possible, remedied at this point. From the table  $p$ , the cloth passes around the roll  $p_1$ , under the machine, then over and under the spreader

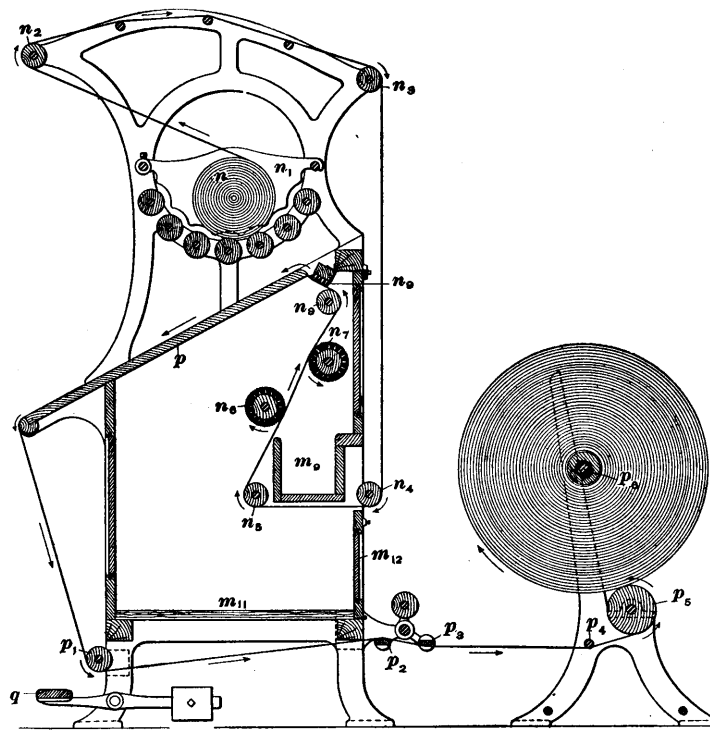

FIG. 2

bars  $p_2, p_3$ , respectively; these spread out the cloth so as to remove wrinkles, after which the cloth passes to the rolling head—under the rod  $p_4$  and partly around the roll  $p_5$ —and is finally wound on the roll  $p_5$ . The outer surface of the roll  $p_5$  is rough, thus enabling it to grip the cloth and draw it through the machine.

A flock box  $m$ , is provided with a door  $m_1$  (Fig. 1), by which the lint that falls from one side of the cloth may be removed. The lint from the other side falls into the space  $m_1$ , and is removed through the door  $m_1$ . There are other doors in the casing by which the brushes may be reached. Threads should be picked off the brushes and lint removed from the box and enclosed space twice a day.

**2. The driving arrangement** of this machine is shown in Fig. 1. The driving belt is shipped from the loose to the tight pulley by means of the foot-board, or treadle,  $q$ . It is necessary, in order to keep the machine in operation, for the attendant to continually press down on this board, since a spring  $q$ , together with a weight at the inner end of the arm supporting the foot-board tend to bring it up and throw the belt from the tight to the loose pulley, thus stopping the machine. On the shaft with the tight and loose pulleys is a pulley  $q_1$  that drives, by means of the belt  $q_2$ , the brushes  $n_1, n_2$ , Fig. 2. On this same shaft is another pulley that drives, by means of the belt  $q_3$ , a pulley  $q_4$  loose on the shaft with the roll  $p_1$ . As the pulley  $q_4$  is loose on the shaft, no motion will be imparted to the roll  $p_1$  unless some other mechanism is brought into operation. This mechanism is as follows: The hub of the pulley  $q_4$  forms one-half of a friction clutch, while the other half, which slides on a key on the shaft carrying the roll  $p_1$ , is controlled by an arm  $q_5$  setscrewed to a rod  $q_6$ . When the belt is shipped from the loose to the tight pulley, by pressing down the foot-board  $q$ , the rod  $q_6$  is turned in such a direction by the arm at its outer end and the mechanism connecting it to the foot-board as to throw the upper end of the arm  $q_5$  toward the machine, thus connecting the two halves of the friction clutch and causing the pulley  $q_4$  to revolve the roll  $p_1$ . If some such arrangement as this were not adopted, the momentum of the machine would cause the roll  $p_1$  to continue to revolve for a certain length of time after the belt was shipped from the tight to the loose pulley. Since, however, in case a defect is noticed in the cloth as it is passing over the inspecting

board  $p$ , it is desired to stop the cloth instantly, the friction arrangement is adopted, which allows the pulley  $q$ , to revolve without affecting the roll  $p$ , in case the two halves of the friction clutch are not connected.

When the operator desires to reexamine any of the cloth that has passed forwards or to return the cloth so as to rectify some fault that has been noticed, the foot-board is allowed to rise, which disconnects the rolling head from the driving power and allows the cloth to be easily pulled back. Some trimming machines are constructed with a reversing motion by which the operator allows the main foot-board to rise and then, by pressing down a foot-board at the side, causes the cloth to pass through the machine in the opposite direction to that in which it usually travels. The brushes do not revolve while the cloth is running in the reverse direction.

3. As it is usually desired to remove the cloth from the trimmer in a large roll, it is necessary to connect the tail-end of each piece of cloth that is passed through the machine with the end of the new piece in the cradle. This is done by sewing the ends of the pieces together by hand.

4. A machine of the type described, when constructed to take 40-inch cloth, occupies a space of 5 feet 6 inches in width and 6 feet 6 inches in depth from front to back. The driving pulleys are 12 inches in diameter with a 2-inch face and when operated continuously at 300 revolutions per minute cause about 50 yards of cloth to pass over the inspecting table per minute. This is a somewhat excessive speed for inspecting, hence these machines are more commonly operated at speeds of from 200 to 240 revolutions per minute. These latter speeds cause from 33 to 40 yards of cloth to pass over the inspecting table per minute.

The trimming machine, although provided with an inspecting arrangement, is not used for the inspection of every style of cloth made in a mill, since some styles require a more careful inspection; in such cases the trimming machine is used merely for the purpose of lightly brushing the fabric, and the cloth is inspected after it has passed the cloth folder

In still other cases, the trimming-and-inspecting machine is used for inspection only, the brushes being dispensed with. This is especially the case with certain fancy fabrics, where the brushing would disarrange the floating ends on the face of the cloth and destroy the fancy effect desired.

---

### FOLDING AND MEASURING

---

#### CLOTH FOLDER

5. After the cloth has been treated either by the shearing-and-brushing machine or by the brushing-and-inspecting machine, it is usually folded on a machine known as a **cloth folder**. A view of this machine is shown in Fig. 3, while a section through the machine is shown in Fig. 4. The roll of cloth  $r$ , Fig. 4, is placed in the stands  $r_1$  and the end passed between the rolls  $r_2, r_3$ , from which it falls into a curved zinc apron  $r_4$ . The rolls  $r_2, r_3$  draw the fabric from the roll of cloth  $r$  at a speed substantially equal to that at which the cloth is folded. Since, however, the folding operation must necessarily be intermittent in its action, a surplus of cloth is drawn from the roll  $r$  and deposited in the apron  $r_4$  before the machine is started in actual operation. This accumulation is used to compensate for the irregularity between the rotary motion of the rolls  $r_2, r_3$  and the intermittent action of the folding mechanism. The zinc apron  $r_4$  also serves to keep the cloth from coming in contact with the floor. From the apron  $r_4$ , the cloth passes in front of the guide roll  $r_5$  and over the guide rod  $r_6$ , from which it passes between a board  $r_7$  and a friction bag  $r_8$ . The cloth then passes forwards and under a friction board  $r_9$  and over a friction board  $s$ , between the guides  $s_1$ , Figs. 3 and 4, and thence around a roll  $s_2$  to the folding blades  $s_3$ , by means of which it is folded on a table  $t$ . The folding blades consist of a frame made of two blades held in end pieces  $s_4$ , each of which has a projecting stud that is supported by a rod  $s_5$  on each side of the machine. These folding blades are operated, as will be explained later, by a rod  $s_6$  on each side of



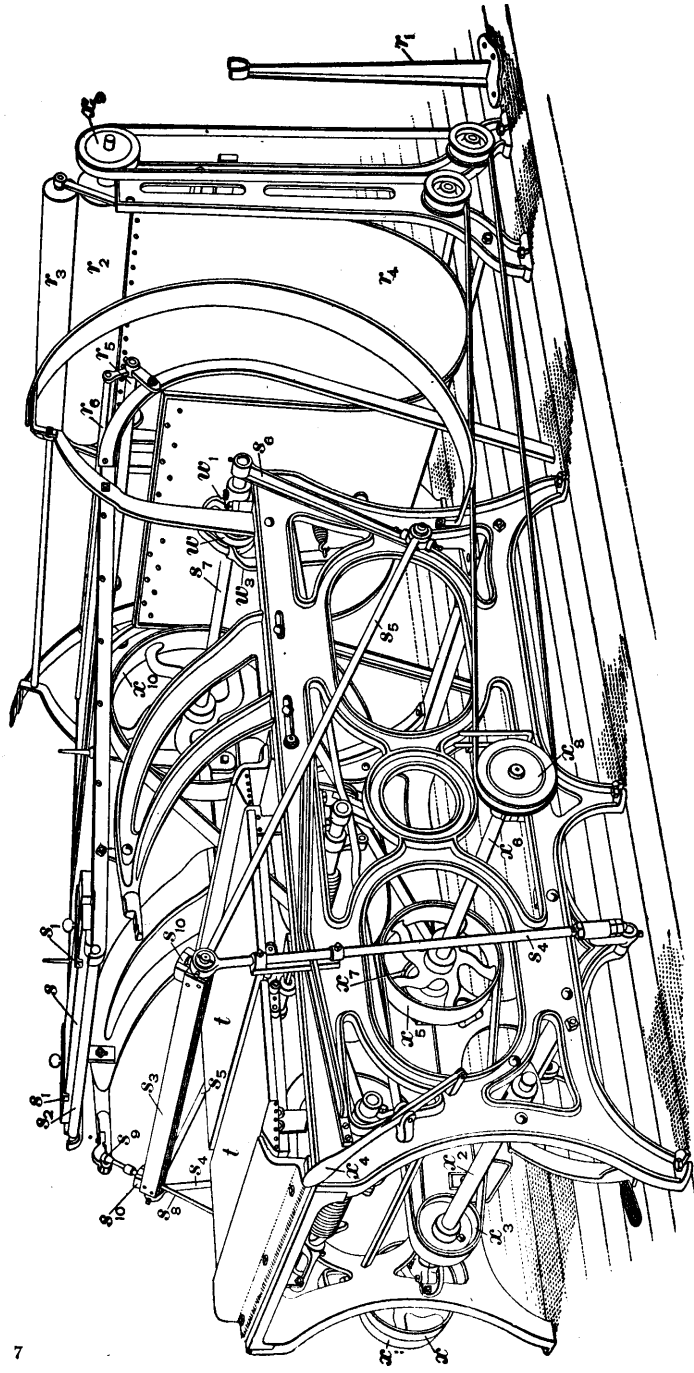

FIG. 3

the machine connected to a crank-arm  $s_4$  that is fast to a shaft  $s_7$ . The position of the folding blades relative to the gripping jaws  $t_1, t_2$  is controlled by a rod  $s_8$ , the upper end of which is held in a swivel-joint  $s_9$ , while its lower end projects and slides through a self-oiling bearing that is on the end of one of the end pieces  $s_{10}$  of the folding blades. As the folding blades are moved back and forth over the table  $t$ , they consequently assume the position shown by the full lines in Fig. 4 when at the back of the table and the position shown by the dotted lines when approaching the front of the table, the faces of the two blades being always at right angles to the swivel rod  $s_8$ . Fig. 5 shows the blades occupying the extreme backward position and placing the cloth under the jaw  $t_2$ .

6. In order to hold the cloth firmly in position as it is folded, the table  $t$  (see Fig. 5) is pressed against the jaws  $t_1, t_2$ ; but in order to allow the folding blades to place each fold of cloth between the jaws and the table, an arrangement is provided to drop, alternately, the latter slightly at each end as the folding blades are placing the cloth between that end and its respective jaw. This table consists of two separate leaves hinged at the center, each leaf acting independently of the other as regards its holding the cloth against its respective jaw. In Fig. 4, the leaves of the table  $t$  are shown lowered so as not to be in contact with the jaws  $t_1, t_2$ , as will be explained later. The forward end of the table is supported by an arm  $t_3$ , Fig. 5, that is connected to a casting  $t_4$  setscrewed to a shaft  $y$ . Forming a part of the casting  $t_4$  is a ratchet  $t$ , that is protected, with the exception of a few teeth at its lower edge, by means of a shield  $t_5$ . Pressed against the shield by means of a spring not shown in the illustration is a pawl  $u$  attached to an elbow lever formed by the arms  $u_1, u_2$ . This lever is loose on the shaft  $y$  and is controlled by a rod  $u_3$  attached to a lever  $w$ , that is in contact with the face of the cam  $w$ . A spring  $v$  that is on the shaft  $y$  has one end attached to a casting  $v_1$ , loose on the shaft, while its other end is attached to a casting  $v_2$ , setscrewed to the

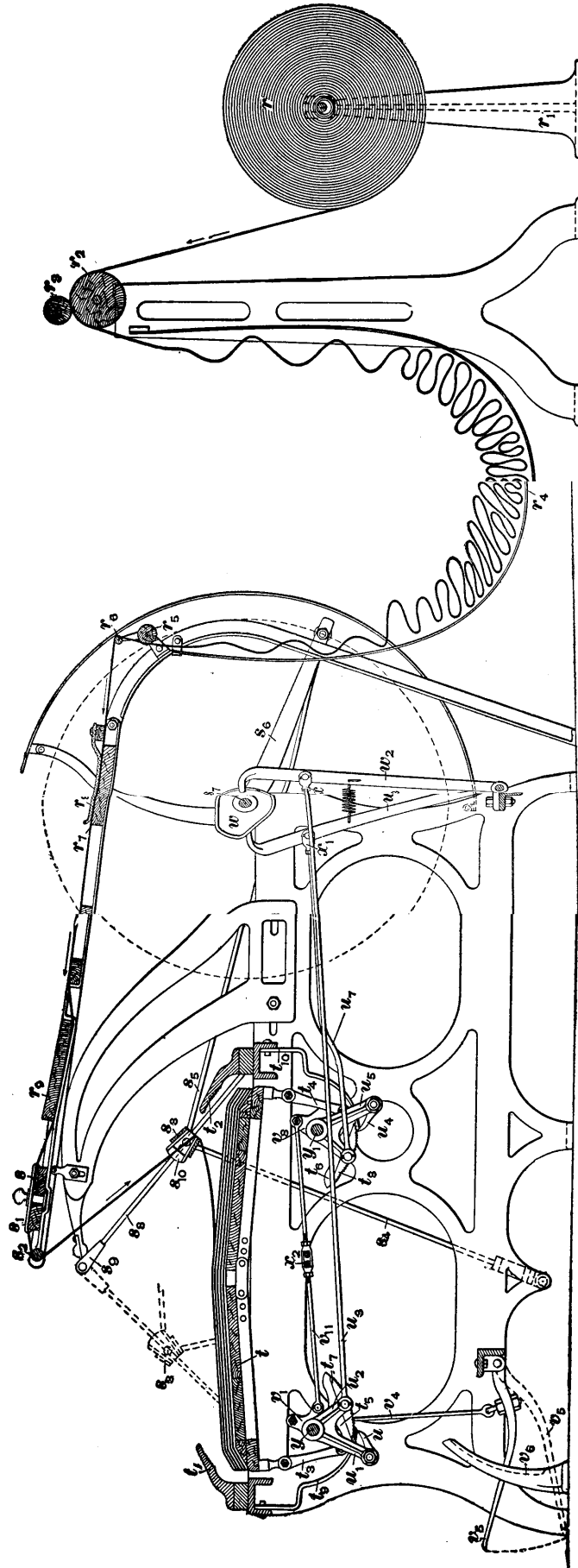

Fig 1

I.L.T. 9 500 B

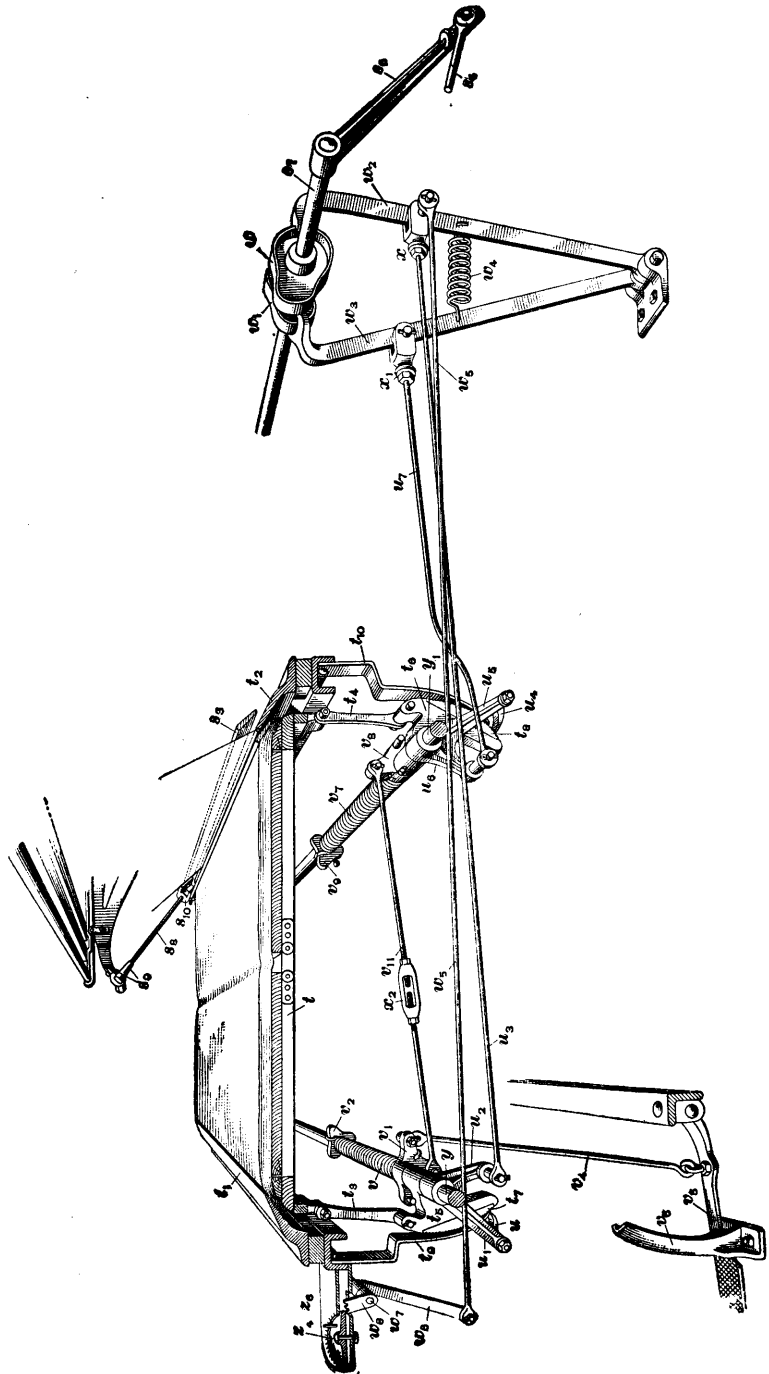

FIG. 5

shaft. These parts are duplicated at the rear end of the table. The casting  $v_1$  is controlled by a rod  $v_2$  attached to a foot-lever  $v_3$ .

The operation of these parts is as follows: In order to place the table  $t$  in position for operating the machine, the folding blades  $s_1$  are first brought over the center of the table and the foot-lever  $v_3$  pressed down until it is held by a catch in the casting  $v_2$ . Pressing down on the lever  $v_3$  draws down the rod  $v_2$ , together with one end of the casting  $v_1$ , which compresses the spring  $v_4$  and turns the casting  $v_1$ . Since the casting  $v_1$  is setscrewed to the shaft  $y$ , any motion of the former will be imparted to the latter and, in turn, to the casting  $t_1$ , which is also setscrewed to the shaft; consequently, as the foot-lever  $v_3$  is pressed down, the casting  $t_1$  will be moved up, which will push the forward end of the table  $t$  against the jaw  $t_1$ . A similar arrangement operates the rear of the table, the motion of the casting  $v_1$  being imparted to a similar casting  $v_2$  through the rod  $v_{11}$ , which results in the casting  $t_2$  being moved up and pushing the rear end of the table against the jaw  $t_2$ . When the folding blades are in the center of the table both the pawls  $u_1, u_2$  are up on their shields, thus permitting the table to be raised; if the pawls were in contact with their ratchets, the castings  $t_1, t_2$  and, consequently, the table could not be raised. The shields  $t_3, t_4$  are so adjusted as to allow their respective pawls  $u_1, u_2$  to engage just the required number of teeth in the ratchets  $t_1, t_2$  as will operate the leaves of the table so that they will lower sufficiently to allow the cloth to be passed under the jaws  $t_1, t_2$ .

The cam  $w$  is so set on the shaft  $s$ , that when the folding blades  $s_1$  are at the forward end of the table, that part of the cam farthest from its center will be in contact with the lever  $w_1$ , thus forcing it to the rear. This action draws the rod  $u_1$  to the rear, together with the pawl  $u_1$ , which will engage with the ratchet  $t_1$  and force down the casting  $t_1$ , thus dropping the forward end of the table  $t$  away from the jaw  $t_1$  and allowing the folding blades  $s_1$  to insert the cloth between these two parts. When the folding blades are

removed from the opening formed between the front of the table  $t$  and the jaw  $t_1$ , the cam  $w$  on the shaft  $s$ , revolves sufficiently so that the lever  $w_1$ , together with the rod  $u_1$ , return to their normal positions. This action allows the spring  $v$ , which has been placed under additional tension by the downward motion of the casting  $t_1$ , to be released slightly, thus turning the shaft  $y$  and raising the forward end of the table  $t$  into contact with the jaw  $t_1$ , so as to hold the cloth firmly in position. As the rod  $u_1$  is moved to the front, the pawl  $u$  slides up on the shield  $t_1$ , thus leaving the ratchet  $t_1$  and casting  $t_1$  under the control of the spring  $v$ . The pawl is thus in position to operate the ratchet  $t_1$ , as the cam  $w$  continues to revolve and the folding blades move forwards again to place the cloth under the jaw  $t_1$ .

A similar connection is made to the rear end of the table by means of the arm  $t_2$  that is connected to the casting  $t_2$ ; this casting is setscrewed to the shaft  $y_1$ , which carries a spring  $v_1$ . The elbow lever  $u_1, u_2$  that controls the pawl  $u_1$  is operated by a rod  $u_2$ , attached to the lever  $w_1$ , that is in contact with the cam  $w_1$  on the shaft  $s_1$ . The springs  $v_1, v_2$ , through their respective connecting-rods tend to keep the levers  $w_1, w_2$  in contact with their respective cams, but in addition a supplementary spring  $w_3$  is provided. When sufficient cloth has been folded and it is desired to remove it from the table  $t$ , the foot-lever  $v_3$  is raised to the position shown by the full lines in Fig. 4. This allows the springs  $v_1, v_2$ , Fig. 5, to turn the pieces  $v_1, v_2$  in such a direction that the pins shown in these pieces hold down the castings  $t_1, t_2$ , thus holding both ends of the table away from the jaws  $t_1, t_2$  and allowing the folded cut to be readily removed.

**7.** The driving of this machine is shown in Fig. 3. The shaft  $x_1$  carries tight and loose pulleys  $x_1, x_2$  that are driven by a belt controlled by the shipper handle  $x_3$ . The shaft  $x_1$  also carries a pulley  $x_4$  that drives, by means of a belt, a pulley  $x_5$  on the shaft  $x_2$ , which also carries a pulley  $x_6$ . The pulley  $x_4$  drives the pulley  $x_5$  on the end of the roll  $r_1$ , which drives the roll  $r_2$  by friction. Another pulley  $x_7$

is setscrewed to the shaft  $x_1$ , behind the pulley  $x_2$ ; by means of a belt, the pulley  $x_2$  drives the pulley  $x_3$  on the shaft  $s$ , that carries the cams  $w, w_1$ .

8. In some cases, other types of tables are used that differ somewhat from the one previously described. One of these types is known as the *automatic drop-center table*, while another is known as the *solid, or one-piece, table*. The automatic drop-center table resembles very closely in general construction the table described in connection with Figs. 3, 4, and 5, but the table is so arranged that its center lowers proportionately with the ends as the pile of cloth gradually increases. This type of table is used for a large variety of fabrics and is especially adapted for extra-heavy or coarse goods; it produces folds of even length, an object that is difficult of attainment in the case of heavy goods or when long lengths of cloth are folded.

The solid, or one-piece, table, although not hinged in the center, is operated in a manner similar to the others as regards the lowering of its ends for the insertion of the cloth under the gripping jaws, and is used principally for silks or extra-fine goods.

9. The folder described is equipped with a low back frame and apron, while another type, which is similar as far as the actual machine is concerned, is equipped with a high front frame. The first type is used principally for unfinished goods, although in some cases it is used for finished goods. The second type is used largely for bleached, filled, or starched goods, prints, gingham, and other finished goods.

The high front frame does not require the use of the zinc apron and the stands at the back of the folder, thus differing from the machine previously described. In this case, a frame supporting rolls similar to  $r_2, r_3$ , Fig. 3, is placed in front of the folder so that sufficient space is left for the operator. The cloth passes from the cloth roll, which is supported by small stands, between rolls similar to  $r_2, r_3$ , and then down around a drop roll, up over another roll, over suitable guides to a roll similar to  $s$ , and thence to the folding

blades of the machine. The drop-roll arrangement takes the place of the apron of the first type.

**10. Measuring Motion.**—In many mills, it is the custom for the operator of the cloth folder to count the folds laid on the table, when the machine does not run too fast for this to be done. He thus ascertains the length of each cut. In other mills, measuring motions are used, which indicate on a dial the number of folds or yards of cloth in each cut. A common type of measuring motion is shown at the front of the machine in Fig. 5 and in detail in Fig. 6.

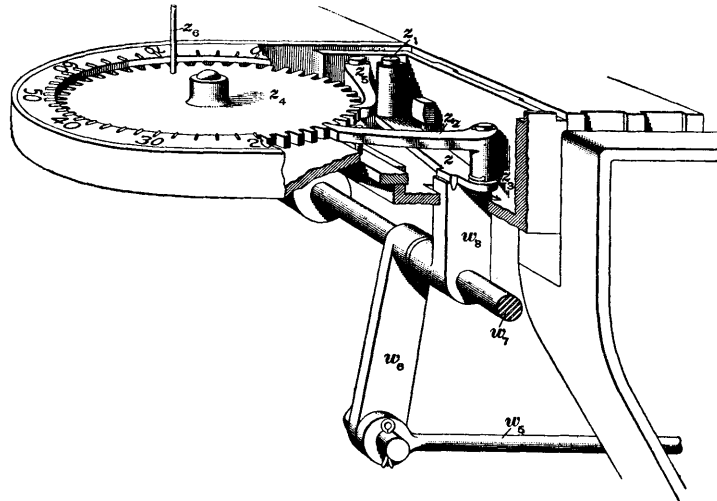

FIG. 6

Attached to the lever  $w_2$ , which is actuated by the cam  $w$ , is a rod  $w_6$  that is connected at the front end to the bottom of an arm  $w_4$ , attached to the shaft  $w_7$ . The cam  $w$  is so set that each time the folding blades approach the front of the machine, this cam presses the upper part of the lever  $w_2$  backwards, thus drawing the lower end of the arm  $w_4$  backwards. As the shaft  $s$ , continues to revolve, the lever  $w_2$  is drawn forwards by the spring  $w_5$ , and the lower end of the arm  $w_4$  pushed forwards. Thus, the arm  $w_4$  makes a forward or backward movement each time that one layer



of cloth is placed on the table, and imparts a reciprocating motion to the vertical arm  $w$ , which is attached to the shaft  $w$ . A horizontal arm  $z$  mounted on a stud  $z$ , carries at its opposite end a pawl  $z$ , also mounted on a stud. The upper end of the arm  $w$ , is connected to the under side of the arm  $z$  by means of teeth and gives an oscillating motion to the end of  $z$  that carries the pawl  $z$ . A spiral spring  $z$ , serves to keep the pawl constantly pressed against the teeth of a ratchet gear  $z$ , the various parts being so proportioned as to cause the movement of one tooth to be imparted to this ratchet each time that the folder blades make their forward movement. While the folder blades are moving backwards, the pawl  $z$ , is being drawn backwards to mesh with the next tooth on the ratchet, a second pawl  $z$ , holding the ratchet in place until  $z$ , assumes the new position.

The cover of the measuring motion is so constructed as to form a circular plate, or dial, which is divided into fifty spaces to correspond with the number of teeth on the ratchet. These spaces, each of which counts two, are numbered from 10 to 100, and as the ratchet carries a pin  $z$ , the number of folds is thereby indicated. For example, if the ratchet is set so that the pin stands against 100, which is really 0, on the cover and the folding blades make twenty-five backward and twenty-five forward movements, the ratchet will have revolved a distance equal to twenty-five teeth, while the pin will have been carried opposite the point marked 50 on the cover, indicating that fifty folds have been made. In case the folding machine is so constructed and set that each fold consists of 1 yard, the length of cloth folded will be 50 yards.

11. The usual length of each fold of cloth is 1 yard, but folders may be constructed to make folds of  $1\frac{1}{4}$  yards, of  $1\frac{1}{2}$  yards, or of 1 meter. This generally requires a different machine, although some machines are so constructed that they may be adjusted to give different lengths; for example, from 1 yard to  $1\frac{1}{4}$  yards or from  $1\frac{1}{4}$  yards to  $1\frac{1}{2}$  yards.

In the case of a 1-yard fold the exact length given by the mill varies from  $35\frac{1}{2}$  to  $36\frac{1}{2}$  inches, according to the policy of the management. In cloth rooms where the fabric is under tension during almost its entire treatment, as, for instance, where it is sewed and rolled, sheared, brushed, and rolled again, it is slightly stretched, and after being folded in loose cuts tends to contract. In such cases, it is often folded slightly more than 36 inches for each so-called yard, and thus controversies with purchasers are avoided.

12. Little need be said concerning the operation and care of a cloth folder, since all parts are readily accessible and easily set. The stands at the back of the machine in which the roll of cloth rests should be so placed as to bring the roll in the center of, and perfectly parallel with, the machine, so as to prevent the cloth passing to the rolls at an angle. Care should be taken to have sufficient cloth in the apron  $r_4$ , Fig. 4, so that the folding blades will take the cloth from it and not from the rolls  $r_2, r_3$ . If the cloth slips between the rolls  $r_2, r_3$  and they do not therefore deliver the cloth fast enough to keep sufficient cloth in the apron, a weight can be attached to each end of the roll  $r_2$ , which increases the friction between the two rolls and prevents this slippage. If the two rolls take in too much cloth for the folder to take care of, the speed of  $r_2$  should be reduced by changing the drive.

The friction placed on the cloth by the bag  $r_5$  and friction board  $r_6$  should also be carefully watched, in order to prevent the cloth being too tight between the roll  $s_1$  and folding blades  $s_2$ . If the friction on the cloth is too great, it will be drawn very tight between the folding blades and the roll  $s_1$ , Fig. 4, which will sometimes cause the folding blades to pull the cloth out from under the jaws  $t_1$  or  $t_2$  when folding; or perhaps the fold may not be pulled completely out of the jaw, but may be started sufficiently to make the length of the folds uneven. If, on the other hand, there is too little friction on the cloth, it will be very loose and will flap considerably in being folded. This will often result in the cloth

sliding ahead of the blades when they stop under the jaws  $t_1$  or  $t_2$ , which will also have the effect of making the length of the folds uneven. The friction can be adjusted by increasing or decreasing the pressure of the friction bag on the cloth. The friction can be increased by folding a piece of cloth of the required weight so that it can be inserted in the friction bag, which is practically a flattened tube of cloth so supported that its under surface comes in contact with the cloth as it passes over the board  $r$ , Fig. 4. The lower edges of the folding blades should always be kept perfectly clean, especially when heavily sized goods are being folded, in which case the folding blades are very liable to become dirty and sticky, and the cloth clinging to them will result in the folds being dragged back.

The length of the fold that is being made by the folding blades should be measured frequently, in order to make sure that it is correct. If the cranks that impart motion to the folding blades need adjusting, this may be done by means of nuts and setscrews on the crankpins. Care, however, should always be taken that the cranks on both sides of the machine are set exactly the same length.

**13.** Care should also be taken to see that the **bushings** at the ends of the folder blades are not too loose, and if it is found that this is the case, the play can be taken **up** by means of setscrews provided for that purpose. Sometimes it will be found that the pawls  $u, u_1$ , Figs. 4 and 5, have become so worn by use that they will not properly engage the teeth of the ratchets  $t, t_1$ . In this case the points of the pawls may be sharpened so that they will properly engage with the teeth of the ratchets, or if the pawls are greatly worn, new ones may be put on. When the teeth of the ratchets become worn or broken, it is usually inadvisable to attempt to repair them by filing or other means; it is far better to put in new ratchets. The folder blades should be so adjusted that there is the same distance between the bottom folder blade and the under side of the jaws  $t_1, t_2$  when the folder blades are in their forward and in their backward

positions. When the folder blades are at the limit of their movements in either direction, the edge of the jaw  $t_1$  or  $t_2$ , as the case may be, should be in line with, or perhaps a little back of, the top edge of the folder blades.

The rods  $u_3, u_7$ , Fig. 5, should be so adjusted that the front and rear ends of the table are lowered at the proper time. This is accomplished by the adjustments at  $x, x_1$  provided for this purpose. These rods, together with the cams  $w, w_1$ , should be so adjusted that the table closes immediately on the withdrawal of the blades from under the jaws. The casting  $v_1$  is connected to the casting  $v_2$  by the connecting-rod  $v_{11}$ , which is provided with a turnbuckle  $x_2$ , so that both ends of the table can be made to act in harmony by turning the turnbuckle to the proper position.

In case the cloth is pulled out from beneath the jaws  $t_1, t_2$ , when the machine is in operation, if there is not too much friction on the cloth it is probable that the springs  $v, v_1$ , Fig. 5, need tightening. These springs, however, should not be tightened so that the pressure of the table on the jaws  $t_1, t_2$  is any greater than is absolutely necessary. Usually the pressure of these springs can be tested by pushing down on the cloth table, and it will generally be found that a fairly strong pressure with the hands is necessary to force the table down against their tension. If lint collects on the ends of the table after the machine has been operated for some time, the table should be carefully cleaned; and it may be that the duck covering at the ends of the table is worn smooth and thin, in which case a new covering of duck or other heavy cloth should be placed on them. The slipping or improper gripping of the cloth at the jaws is also caused by the beveled portions of the ends of the table being warped or worn excessively. This can be tested by inserting a piece of paper at intervals throughout the entire length of the jaws; the paper should be gripped between the jaws and the ends of the table. These last two faults are the most common.

The speed of a cloth folder is spoken of as so many yards per minute; that is, while the machine is actually running it is folding that number of yards per minute. The total

number of working minutes per day, however, could not be multiplied by the yards per minute in order to obtain the production of the machine, since a large portion of the operator's time is consumed in separating and removing the cuts as they are folded.

14. Cloth folders that fold the cloth in folds 1 yard long are constructed with the tight and loose pulleys  $x, x_1$ , Fig. 3, 10 inches in diameter, and when running 250 revolutions per minute will fold 75 yards of cloth a minute, which is a fair average speed for folding ordinary fabrics. A machine of this description occupies a floor space of about  $5\frac{1}{2}$  feet by 10 feet. Cloth folders that are so constructed as to fold the cloth in folds  $1\frac{1}{4}$  yards in length also have driving pulleys 10 inches in diameter that, when running 200 revolutions per minute, will cause the machine to fold 75 yards of cloth per minute. On some fabrics a cloth folder, if operated by a skilled operator, may be run at a faster speed than that given above, but on the other hand it will be found that where goods are very wide or are very light and delicate, the speed of the machine should be correspondingly reduced. In setting up a cloth folder it is very important that the machine should be set perfectly level. This may be ascertained by placing a level on the front girt of the machine and also on the cam-shaft  $s$ , Fig. 3.

The cloth, as it comes from the shearing-and-brushing machines and is carried to the folder, is in the form of a large roll, containing a number of cuts stitched together. However, as the cloth is folded at the front of this last machine, the operator watches closely as it passes through, and as each cut is folded, detaches it from the rest of the cloth. Thus, there will be only a cut of about 50 yards in each separate piece of cloth that is taken from the folder. In some mills it is the custom to leave the cloth in double cuts, each separate piece in this case being about 100 yards in length.

**MEASURING ATTACHMENTS**

**15.** Cotton cloth when intended for shipment in bales of either single or double cuts is usually measured at the cloth folder, as already described; but when it is to be shipped in a roll, it is usually measured at the rolling head of the last machine through which it passes before being ready for shipment, or at the calender-rolling attachment, if it passes through this process. It is possible, however, to apply measuring rolls and dials to almost any machine through which the cloth passes, as these are constructed in various sizes and styles, with suitable brackets for attaching them, either to the sides or tops of machine frames or to horizontal rails or upright posts.

The usual arrangement consists of a worm on the end of the measuring roll, driving a dial gear, the length run being indicated by a pointer, or finger. When cloth is handled in short lengths, a single dial is used, to register up to 60, 75, or 100 yards. For large rolls, double dials are used to register a maximum of either 2,600 or 5,100 yards, while for recording very much greater lengths, such as the total amount of cloth passed through a machine in a week, counters that will register up to 100,000 yards are applied. The gearing between the measuring roll and the finger on the dial is selected so that as a point on the circumference of the measuring roll travels 36 inches, the finger moves over a space indicating 1 yard on the dial.

---

**STAMPING**

**16.** **Stamping** is the operation of impressing on the outside of a cut of cloth a combination of marks to give information as to the name of the mill where the goods was woven, the name of the cloth, the weight and length of the cut, and frequently a trade mark, etc. The imprint is usually arranged so as to be long and narrow—not more than 15 inches in width and from 20 inches upwards in length, according to the style of the design and the information to

be given. It is usually stamped on one-half of the outside fold of the cut; that is, the cut of cloth after leaving the folding machine in 36-inch folds is doubled once so as to reduce the width to 18 inches, and the imprint stamped on one of these halves. In some cases, more particularly where a 45-inch fold is used, one-third of the width is turned inwards on each side, thus reducing the width of the fold to 15 inches, and the impression is then made on the central portion, at the back of the cut. Usually blue ink is used to make the impression, but black, red, and other colors are sometimes used.

The stamps by which the impressions are made consist, in some cases, of wooden blocks with the design or letters that are to be imprinted cut in relief. More commonly, however, they consist of smooth blocks of hardwood into which have been driven the letters or portions of the design previously formed out of strips of copper, the edge of the strip forming the outline of the design desired. The portion of the stamp that indicates the number of yards is usually separate from the remainder, as the length of the cuts is not always the same, thus necessitating a separate series of stamps, the proper ones being selected for each piece. The remainder of the imprint may be in one or more pieces, preferably in two or three; for instance, the name of the mill on one, the trade mark on another, and the weight per yard on a third.

Stamping is performed either by hand, in the case of a small mill, or by machine, in the case of a large mill. A stamping machine operated by power will stamp the product of three thousand looms and is somewhat expensive; consequently, it is not usually introduced in mills with less than five hundred looms running on goods that have to be stamped.

**17.** The **inking arrangement** is somewhat similar whether for hand or power; it consists of a copper box either filled with water and having a rubber covering or containing a rubber pad filled with water. This is for the purpose of providing a surface that yields to the slight inequalities in the surface of the stamp and affords a means of equalizing

the supply of ink. The surface of the rubber is covered with soft cloth or flannel in the case of hand stamping, to which the ink is applied by means of a brush. In the case of machine stamping, the pad is covered by an endless apron, which travels over the surface of the pad and conveys the supply of ink. When goods are stamped by hand, the impression is made just as with an ordinary rubber stamp for making an impression on paper, namely, by first pressing the stamp on the inked surface and then on the cloth, this being continued with different stamps until the design desired is impressed.

**18. Stamping Machines.**—The machine for stamping consists of a substantial framework to support the various mechanisms required. Vertical rods that slide in suitable guides carry a cross-bar to which are attached as many stamps as are required to complete the design, the arrangement being such that the cross-bar may be adjusted at either end to give a uniform impression. The rods supporting this arrangement are actuated by cams, which raise and lower the cross-bar, and when the latter is dropped into position, another cam produces the desired pressure to make the imprint. A sliding table moves forwards to receive the piece of cloth to be stamped, which is laid on the table in any desired position, determined by adjustable sides; the table then travels backwards until it is in position under the stamps and remains there a sufficient length of time to allow the impression to be made and the stamps to be returned. The table then moves forwards again to admit of the removal of this piece of cloth and the insertion of another piece, during which interval the stamps have again moved downwards, but this time into contact with the stamp pad, so as to receive another supply of ink in readiness for stamping the next piece of cloth.

Stamping machines carry tight and loose driving pulleys 18 inches in diameter and  $2\frac{1}{4}$  inches wide, revolving at a speed of about 40 revolutions per minute. The space occupied by such a machine is about 6 feet  $\times$  5 feet.



If all the cuts are exactly equal in length, which seldom occurs, the mark to indicate the number of yards in the cut can be impressed at the same time as the other parts of the design; but it is more common to stamp these afterwards by hand, since there is usually a slight variation in the length of the different cuts, so that it may be necessary to stamp one length as 49 yards, the next as  $49\frac{1}{2}$ , a third as 48, a fourth as 50, etc.

---

### PREPARATION FOR SHIPMENT

---

#### BALING

**19.** To prepare cloth for shipment it is either baled or cased, usually the former. Baling differs according to whether the goods are intended for domestic or foreign shipment, being much more carefully performed in the latter case. When cloth is to be shipped from the mill to the bleacher, converter, or the domestic consumer, a number of cuts (varying according to their length and weight and the size of bale desired) are taken from the compartment in which they are stored in the cloth room, the number of yards and weight of each cut being entered in a book or on a sheet of paper. Each cut is folded one or more times, to reduce its width to the desired size, when it is ready for baling.

**20. Baling Presses.**—Three types of baling presses are used for cloth intended for domestic shipment—the **togglejoint press**, the **screw press**, and the **hydraulic press**. Screw presses are not now usually adopted, owing to their slow action, and hydraulic presses are expensive and usually too powerful for domestic baling; the togglejoint press is therefore most commonly installed in cotton cloth rooms for this purpose. Fig. 7 is a perspective view of a togglejoint press. The framework of the press is composed of the bed *b*, on the upper surface *a* of which the bale is formed, and the head *c*, both of which may be made of either cast iron or wood. The upright rods, or columns, *d*

are usually made of steel and serve to connect the bed *b* with the head *c*. Running horizontally across the machine below the head and between the columns is the screw *e*, which imparts motion to the working arms *f*, *f*<sub>1</sub>, *f*<sub>2</sub>, *f*<sub>3</sub>. This screw has a right- and left-hand thread and carries two

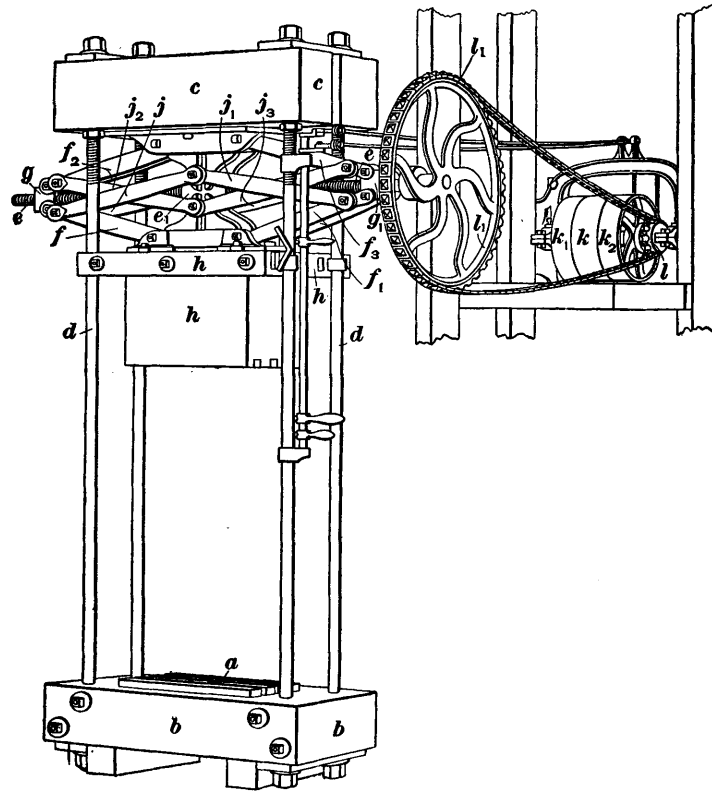

FIG. 7

nuts *g*, *g*<sub>1</sub>. The arms *f*, *f*<sub>1</sub> are pivoted at one end to the nut *g*, while their other ends are connected, respectively, to the follower *h* and to a bracket attached to the head. The arms *f*<sub>2</sub>, *f*<sub>3</sub> are similarly connected on the other side of the head. By this means, when the screw *e* is turned in one direction, it will draw the nuts toward the center of the

screw, straighten out the working arms, and force down the follower *h*. When the screw is turned in the opposite direction, it will draw the nuts out, cause the arms to fold up, and thus raise the follower. The arms *j, j<sub>1</sub>, j<sub>2</sub>, j<sub>3</sub>* serve merely to steady the working parts. The bed and follower are constructed with recesses through which cords may be passed while the cloth is under pressure, and secured before the pressure is released.

An automatic power attachment is used in connection with the press and consists of a bracket and short shaft containing three pulleys—*k*, which is attached to the shaft, and *k<sub>1</sub>, k<sub>2</sub>*, which are loose on the shaft. The bracket also carries two rods, with belt shippers, springs, and lever attachments for shipping the belts from one pulley to another. One loose pulley is driven by a crossed belt, while the other is driven by an open one and consequently revolves in the opposite direction. On the shaft with the pulleys is a small sprocket gear *l*, which drives, by means of a chain, a large sprocket gear *l<sub>1</sub>* on the same shaft as the screw *e*. In operation, one belt is first shipped to the tight pulley, which turns the screw in such a direction that the follower is forced downwards until the cloth has been compressed sufficiently, when the belt is automatically shipped to its loose pulley. After the bale has been secured with ropes or bands the other belt is shipped from its loose pulley to the tight pulley, which reverses the screw and raises the follower.

**21.** Before forming the bale of cloth, the required number of pieces of rope (if rope is to be used) of sufficient length to pass around the entire bale are placed in position in the grooves in the bed; it is becoming the practice now to use, instead of rope, steel bands cut to suitable lengths and secured by buckles. The method of passing these around the bale, however, is much the same in either case. After the ropes or bands have been properly placed in the grooves, a piece of burlap of sufficient size to cover the lower side of the bale and half of the surrounding four sides is placed in position on the top of the bed. The required number of

cuts of cloth are then placed on this burlap and covered with another piece of burlap similar to the first, after which the follower is allowed to descend and subject the cloth to the necessary pressure to produce a bale of the required size. The burlap is then drawn up from the bottom and down from the top so as to overlap and the edges are sewed together. The ropes or bands are next secured around the bale and the follower allowed to rise, after which the bale is removed and marked with the necessary shipping instructions and description of its contents, such as style, number, length, or other particulars. This marking is generally done by means of a stencil. If the bales are usually shipped to the same destination and they are usually marked with certain standard markings, it is customary to have these stencils made of brass plate, the letters being cut out. In those mills where the addresses to which shipments are to be made are constantly changing, stencil machines are being introduced which prepare paper stencils in a very short time. After the bales are completed they are trucked to the storehouse and held for shipment.

**22.** It is not customary to completely enclose the bale of goods in burlap, especially if it is to be transported a short distance, in which case it is common to use only a small strip of burlap for the bottom and another for the top, leaving the sides partly exposed. This is not a good practice, since bales of cloth are carelessly handled in transportation, and the exposed cloth may come in contact with the bottom of a car that is dirty or that has been used for oil, acids, or some other substance that has a detrimental effect on the fabric, or at any rate soils the edges of the folds. Similarly, bales become marked with grime and dirt when laid on wharves. As a result, when the cuts are opened, streaks of grime or dirt will frequently be found running across the cloth where it has been folded or along the selvages. These marks are known to the converters as *bale marks* and are very objectionable, as it is impossible in many cases to remove them in bleaching.

It is customary at the same time that the cuts are piled up in the press to make a record of the contents of the bale; that is, the style of the cloth, the number of cuts in the bale, the number of yards in each piece, the weight of each piece, the total number of yards, the total weight of cloth, and the average weight per yard, thus affording a means of ascertaining whether the cloth is being manufactured according to the weight per yard ordered.

**23. Foreign Shipment.**—When goods are to be shipped abroad, especially for long distances by ocean transit, the style of baling is somewhat different and much more completely and carefully performed. Bales for ocean shipment are pressed more closely than for domestic shipment, since ocean rates depend on the space occupied. The covering of the bales must be more elaborate, in order to resist moisture. Hydraulic presses are almost always used for baling cloth for ocean shipment, on account of the greater pressure that can be obtained. The bales are also much heavier than domestic ones, from 100 to 200 cuts being sometimes baled together; but this depends on the instructions of the foreign buyer, since in some cases small bales are made, to facilitate transportation to the interior of foreign countries.

The methods of covering foreign bales vary according to requirements, but one example will serve to illustrate all. On the bottom platform of the press a piece of burlap or coarse linen canvas is laid, and on the top of this, tarred cloth, which is canvas covered with pitch to make it waterproof. Above this, one or more layers of heavy gray or brown absorbent paper are laid, so as to prevent the pitch striking through to the cloth, and on this, thick white paper is placed. The cloth is then piled up to the required height and on the top paper and cloth are laid in reverse order, namely, white paper next to the fabric, then gray or brown absorbent paper, then the waterproof tarred cloth, and above it the outside covering of burlap. Sometimes additional sheets of oiled linen cloth are placed next the outer layer of paper, with still another layer of absorbent paper next the white

paper. The lower platform of the press is raised by hydraulic power and the ends of all the layers folded so that they will overlap and yet remain in their respective relative positions to the cloth. The outer coverings are sewed up at the sides and ends, after which four or more steel bands, usually painted to prevent corrosion, are secured around the bale and fastened by rivets, after which the pressure is released, the bale removed, and the necessary shipping marks placed on with stencils, together with the customary injunction, "Use no hooks."

---

#### SHIPMENT IN ROLLS OR CASES

**24.** It is becoming more and more customary to ship ordinary cotton cloth from the mill to the converter in rolls, just as it leaves the shearing-and-brushing machine, or, where it is not required to be sheared and brushed, as it leaves the sewing-and-rolling machine; that is, after the wooden roll on which the cloth is wound at these machines is removed. In this case a piece of burlap is placed around the roll and sewed where the ends overlap. The roll is then placed on its end and a small piece of burlap tucked in the upper end and sewed around the end of the roll along the edge of the selvage of the piece of burlap previously placed around the roll of cloth. The roll is then stood on this end and the opposite end covered in the same way, thus completely enclosing the cloth.

**25.** Another method of shipment is to pack the cuts of cloth in cases. This is common for gingham and those fabrics that leave the mill in the condition in which they are forwarded to the dry-goods commission houses, ready for the dry-goods store. The cases are constructed to hold the required number of bolts of cloth and are lined with paper. After the cuts have been packed in the case, they are pressed down and the cover nailed on; the cases are then stenciled with the required shipping instructions, after which they are removed to the storehouse to await shipment.

**CLOTH INSPECTION**

**26.** The proper inspection of cotton cloth is one of the most important matters in connection with the operation of a cloth room. It is important to have every piece examined in order to detect faults and trace them to the weaver who has caused them or allowed them to pass. It is also a means of detecting faults in the cloth that cannot be attributed to the weaver, but to some other operative in the weaving department or in some other department; as, for example, wrong drafts in the drawing-in room, or unsuitably mixed cotton, or defective yarn produced in the spinning room. By the inspection of cloth the different cuts are also graded for shipment. Almost every mill divides the cuts into two grades—firsts and seconds—and some into three or more grades, depending on the strictness of the buyer's requirements or the reputation that the mill desires to maintain. In addition to the regular grades, the inspection also results in producing a certain number of remnants, or *mill ends*.

**27.** Among the principal faults to be watched for is that known as *ends out*, where the weaver has failed to replace a broken end or ends as soon as the breakage occurs. *Mis-picks* result when the loom, after having been stopped by the filling breaking or running out, has run for a pick or two before being entirely stopped and then the weaver in starting with fresh filling has allowed the first pick of the new filling to lie in the same shed as the last, thus giving two consecutive picks in the same shed; this trouble is accentuated in fancy or colored goods, where the additional defect of making a break in the pattern results. *Broken picks* result when a pick of filling breaks part way across the shed and is not removed so as to be replaced by a complete new pick. *Bad selvages* are due to various causes. *Smashes* are produced by the shuttle remaining in the shed and breaking out a portion of the warp yarn; these can be remedied, if not of serious proportions, by the weaver piecing up the warp and making a new start in such a way as to avoid evidence of there having

been a smash, although this is not always done. *Thin places* in the cloth may result from starting the loom improperly after a breakage in filling, or may be caused when the loom is running; *thick places* are also caused in a similar manner, there being too much filling in a given space in comparison with the remainder of the fabric. *Floats* occur where there has been an entanglement in the warp resulting in imperfect interweaving for a short distance filling-way and warp-way, thus producing a hole in the cloth or a thin place where it has been scratched over. Most of these defects are the fault of the weaver.

*Slubs*, or *slugs*, and *thick places* in the filling are due to defective yarn preparation, attributable to departments previous to the weaving department. An *insufficient* or an *excessive number of picks* per inch results when the wrong take-up gears are placed on the loom by the fixer or second hand; and many other defects of a similar nature occur that are not the fault of the weaver. The duty of the weaver-room overseer, in a small mill where he is also the cloth inspector, is to call the attention of the proper officials to these faults, that they may deal with them in such a manner as will prevent or reduce the frequency of their occurrence and may also decide whether the cloth shall be considered as first quality or as seconds.

In case a defective length of cloth must be entirely cut out, it is customary in most mills merely to lay the two remaining pieces together and mark the cloth with the combined length of the two pieces, thus,  $25 + 20 = 45$ . This forms a *blind end*, and if shipped to the converter in this condition, this defect will not be discovered until the cloth is being run through some machine at a rapid rate, which will cause much loss of time in threading the cloth through the machine again and frequently the spoiling of a number of yards by the defective treatment of that portion of the cloth. The converter prefers that the two cut ends should be sewed together so as to make one continuous cut. Whenever it is necessary to sew two ends of cloth together for this or any other reason, it should always be done by



machine and not by hand, since hand-sewed seams in the gray cloth almost always break when they are subjected to the strain that is applied in certain converting machinery, thus causing entanglement and spoiling a considerable length of the fabric. Similarly, when in a piece of cloth a place that has been allowed to pass through the loom without having filling inserted is discovered, the two woven portions merely being connected by warp ends, this should be cut out and the ends sewed together. Since the warp alone is not sufficient to stand the strain of the converting processes the cloth would be broken or, in case of singeing, the ends would be burnt away, thus causing a break.

**28.** The cloth-room inspector should be trained to consider the requirements of the converter as far as possible, in order to obtain for the mill a good reputation for delivering cloth that causes little trouble in bleaching, dyeing, or printing. For example, the inside end of a piece of cloth should be left flat when the folds are doubled over for shipment and not allowed to crumple, as is often customary, since this causes wrinkles for  $\frac{1}{2}$  yard or more, which cannot easily be removed. The converters also appreciate a good selvage to a fabric, since defective selvages, by breaking, cause as much trouble as any other fault in cotton cloth, if not more. Many of the faults produced in weaving show up much worse after the cloth has been dyed or bleached.

The practice of placing pins or leaving needles in cloth should not be permitted; they should be looked for by the inspector and removed, as well as broken teeth of combs that have been used for scratching up defective places. Any such metallic substances damage the rolls of the converting machinery or adhere to their surfaces, thus producing a series of damaged places for a considerable distance.

No black lead (graphite) marks should be permitted, nor marks made by any material containing wax or grease, since such marks will not bleach out. Pure chalk crayons only should be used in any department for marking cotton goods, especially cloth that is to go to the converter.

**29.** The standard of quality for grading the cuts depends on the policy adopted by the mill and the requirements of the buyer, so that it is difficult to give any hard and fast rule for this. In general, it may be stated that where the requirements are fairly stringent and where cuts that contain any serious imperfections or any excessive number of minor imperfections are not classed as first quality, the number of seconds should not exceed 2 per cent. in a well-managed mill; it should be less than this for ordinary plain goods and not greatly in excess for fancy or colored goods. Some mills making both plain and fancy goods keep their seconds at less than  $1\frac{1}{2}$  per cent. the year around.

**30.** Cloths may be inspected in the cloth room in three ways: (1) at the brushing-and-inspecting machine shown in Fig. 1; (2) by means of an inspecting machine of simpler construction, consisting of little more than a black slanting table over which the cloth is drawn by hand or by means of revolving rolls which can be readily stopped in case a defect is noticed; (3) fold by fold, after it has been removed from the cloth folder and laid on a flat table.

The most common and perhaps the most satisfactory system of inspection is the one last named. The piece of cloth as it is taken from the folder is doubled over on itself once and each fold turned over by hand, and any defects noted. After one side has been inspected, the piece is turned over end for end and the other half of each fold examined in the same way. This is a more expensive system than the first and second, but results in a more careful examination, and as the piece of cloth is stationary the minor defects can not only be observed but in some cases remedied. For a more careful inspection, the cloth is laid flat as it comes from the folder and an entire fold turned over each time. In the larger cloth rooms the inspection is usually performed by girls, who refer especially defective pieces to the superintendent of the cloth room for final inspection and action.

**31.** The appliances required in a cloth room are scissors, cloth nippers, weaver's combs, a block of wood, a cloth

rubber, water, soap, and oxalic acid. The scissors are for the purpose of cutting out defective lengths of cloth, separating the pieces of cloth into single cuts, and clipping off loose ends of yarn. The nippers, shown in Fig. 8 (b), are for the purpose of grasping slubs and lumps in the cloth that have not been otherwise removed, and drawing them out. The comb, Fig. 8 (a), consisting of a number of sharp teeth leaded into a brass back, is for the purpose of scratching adjoining ends of warp or picks of filling over a thin place

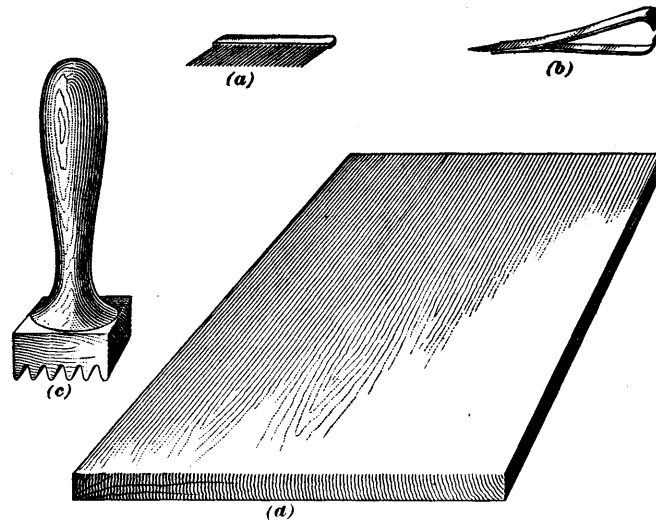

FIG. 8

or hole; as, for example, after a slub has been removed, the comb is used to draw over the open space preceding or succeeding picks of filling and remove any evidence of a flaw in the cloth. Small floats are scratched over in the same way. Spots or streaks of black oil are often found in cotton cloth, and if caused by a spot of oily lint, can sometimes be picked out with the nippers, but more frequently after doing so, or in case it is impossible to remove it with the nippers, the black place must be soaked in oxalic acid and rubbed until the black spot disappears, after which that portion of the

cloth must be carefully and thoroughly rinsed out with clear, cold water, so as to prevent the action of the acid continuing and *tendering* the fabric.

In some mills the use of oxalic acid for this purpose is prohibited, and oil stains are removed by means of soap and water. A good plan is to have a piece of whitewood board about 9 inches wide, 18 inches long, and  $\frac{5}{8}$  inch thick, Fig. 8 (*d*), which is used bare or covered with several thicknesses of cloth and placed under the oily mark. A little water is then poured on the fabric and the spot rubbed with white soap of good quality. When it has become thoroughly saturated with soap and water, it is rubbed with a wooden cloth rubber, such as is shown in Fig. 8 (*c*), which is an implement having the upper part fashioned into a handle and the lower part corrugated, until the marks are effaced, after which the cloth is rinsed with clean water and wiped as dry as possible with a clean cloth.

---

#### SUMMARY

**32.** A summary of the combinations of machines and processes used in the cloth room is now appropriate. The treatment of fabrics in the cloth room and the number of processes used depends on: (1) the class of goods made by the mill; (2) the differences of opinion among mill men as to what is suitable treatment even for the same fabric; (3) the policy of the management, whether tending toward economy in cost at the expense of quality or the desire to produce the best quality irrespective of cost.

Inspection and folding or rolling are the only absolutely essential processes in the cotton cloth room. Some mills making standard goods, such as print cloths, where little advantage is to be gained by making a high quality and where the only thing to be noted in the cloth room is to prevent too low a quality, are content with passing the cloth directly from the loom through a folder, inspecting it afterwards by hand, and then baling the cloth for shipment. Where such fabrics are shipped in a roll, they are passed

through a sewing-and-rolling machine, inspected at the same time, and shipped in the roll; or sometimes after being sewed and rolled they are passed through an inspecting machine, rolled, and shipped.

The later processes of brushing, shearing, and calendering depend on the conditions named. Shearing is adopted only when it is desired to bring out the pattern strongly or produce a comparatively bright face on the fabric, and where shearing is adopted it is always combined with brushing. Shearing-and-brushing machines may be used for coarse, medium, or fine fabrics, the differences being in the adjustment of the shears and brushes, since a delicate fabric will, of course, not stand the same amount of shearing and brushing as a coarse or medium fabric. The number of shears and brushes, generally speaking, is determined by the cloth to be operated on; the larger numbers being used for heavy and coarse fabrics. In some cases a large number are used for fine fabrics, each being set to operate lightly.

Emery rolls, beaters, and card rolls are usually applied only to those machines intended for dealing with coarse or medium fabrics, especially such as duck, ticking, sheetings, twills, etc. Such heavy fabrics will withstand the pressure and strain brought on them by the emery rolls, the beaters, and the card rolls, being finally treated by stiff brushes and either calendered or not, according to the requirements of the mill or of the buyer. For such fabrics it is not common to use shears, since sheetings and similar goods are enhanced in value if they have a full, soft appearance and feel.

The removal of dust, dirt, and small particles of foreign matter is desirable for all fabrics, and consequently brushing combined with a strong exhaust fan for removing the dirt brushed off is common to the treatment of almost all fabrics. In general, therefore, it may be stated that coarse, heavy goods, where a bare surface is not desired, are treated by emery rolls, beaters, card brushes, stiff brushes, and are sometimes calendered. Coarse goods, where a full, soft face is not desired, are treated by shearing also. Medium

and fine goods, where a bare face is desired, are sheared and brushed, but not usually calendered, the extent of the shearing and brushing being determined by the number of shears and brushes in the machine and by the closeness or openness of the setting. Fine goods, of course, will not stand as close a setting as medium and coarse goods. Sewing machines are only used where the fabric is to be shipped in a roll, or where a number of cuts are to be sewed together to facilitate the passage of the cloth through the shearing, brushing, or calendering machines. Otherwise, the sewing-and-rolling machine has no part whatever in changing or improving the appearance of the fabric.

The absolutely necessary processes in a cloth room are merely those that change the form from that in which the cloth leaves the loom to that in which it is to be shipped, namely, the folding or baling, or in some cases rolling, and, where required, stamping or ticketing. All other processes are optional. In fine-goods mills, especially those making fancy goods, and where the cloth is to be immediately forwarded to the converter, it is not usual to adopt any machines except the folding and inspecting machines and baling presses. The pieces are not even sewed together, but each piece is inspected on a machine of simple construction, then folded, inspected, and afterwards baled.