

# CLOTH ROOMS

Serial 500A

(PART 1)

Edition 1

---

## CLOTH-ROOM PROCESSES AND MACHINERY

---

### INTRODUCTION

1. After cotton cloth has been woven and taken from the loom, it is removed to what is known as the **cloth room**, where it passes through certain processes that are necessary or desirable before it is ready to be shipped from the mill to the dry-goods merchant, converting establishment, exporter, clothing factory, or wherever it is intended to be delivered, according to the use to be made of it or the customary method of distribution to the ultimate purchaser. Such shipping of the cloth may take place through the dry-goods commission merchant or through his order; or it may be done directly by the mill, according to the system of selling the goods that is adopted. A complete list of operations that occur in American cotton-mill cloth rooms is somewhat as follows:

1. *Receiving and checking* the cloth from the weave room, for the purpose of verifying the amount received of each style and checking the weave-room report of cloth produced, is required in order to make certain that all the cloth that has been woven or for which the weavers are paid is received in the cloth room, also in order to keep the management informed as to the amount of cloth being received of each style, so

that progress on various orders can be ascertained and arrangements made for shipping.

2. *Inspecting* is for the purpose of examining the cloth received from the weaver, with a view to detecting faults in the fabric and taking suitable action thereon to prevent a repetition of them, and also for the purpose of sorting out the pieces of cloth into first grade, second grade, and in some cases third grade.

3. *Sewing* is the stitching together of the ends of each two consecutive pieces of cloth that are intended to form a continuous length, in order to facilitate some succeeding treatment and to conduct it with the greatest economy.

4. *Rolling* is the process of winding, in a large roll, the continuous sheet of cloth that has been produced by sewing the ends of separate pieces together.

5. *Brushing* is the process of treating the cloth, on one or both sides, with revolving brushes (usually bristle brushes, but sometimes wire brushes followed by bristle brushes), for the purpose of removing loose threads, loose fibers, dust, pieces of leaf, stalk, or other foreign matter, and also imparting a smooth clean surface to the fabric and laying the projecting fibers in one direction.

6. *Scraping and beating* is performed on coarse and heavy fabrics for the purpose of rubbing and striking from the cloth small projecting particles of a fibrous nature (such as knots, lumps, and nubs) that are produced in the processes of manufacture, or those of a foreign nature (such as motes, leaf, and stalk) that come with the raw cotton; these are difficult to remove by means of a mere brushing action.

7. *Shearing* is the operation of cutting from the face, or sometimes from both the face and the back of the fabric, projecting threads and fibers, the presence of which is undesirable in most fabrics.

8. *Calendering* is a compressing and smoothing action produced by passing the fabric between heavy hot or cold rolls to impart a smooth surface to the cloth.

9. *Folding* is the process of arranging the cloth in superimposed layers, each of the same length, so as to provide a

suitable form in which the fabric may be baled for shipment and offered for sale in dry-goods stores, as well as to give a ready means of ascertaining the length in each piece from the number of folds obtained.

10. *Stamping* is the operation of impressing on the outside of a folded piece of cloth such marks as may be required or desired, as for example, the name of the mill, the name of the fabric, the number of yards in the piece, and (especially for export) the trade mark of the manufacturer.

11. *Ticketing* is the operation of attaching to the folded piece of cloth some printed ticket, frequently highly colored or strikingly designed, which may contain the name of the mill, the name of the fabric, the trade mark, the length or width of the goods, and such other features of a like nature as are desirable. Sometimes this is done by means of paper bands passed around the piece of folded cloth and pasted in position; this may be adopted instead of, or in addition to, stamping and ticketing.

12. *Baling* is the packing of a number of pieces of cloth within a covering of burlap, or other material, suitably secured by ropes or iron or steel bands, to prevent the cloth becoming soiled or damaged in transit, and to facilitate transportation by reducing the bulk.

2. In this list only those processes that are usually found in the cloth rooms of American mills are defined. No mention is made of such processes as singeing, bleaching, tinting, starching, tentering, mordanting, dyeing, printing, filling, mercerizing, or associated processes that are necessary in the case of some fabrics to prepare them for the market. Though in a few cases one or more of these processes are conducted in the same establishment as that in which the goods are woven, yet this is the exception rather than the rule, and consequently all such processes are ignored here, since they more properly belong to the operation of a converting, or as it is sometimes called a finishing, establishment.

The expression *finishing* is sometimes applied to the processes that peculiarly belong to the cloth room of a mill, but

it should not be used in this connection, since it is misleading, although there is a precedent for such a use of the term in connection with other industries, as for example in the knitting-goods industry, where finishing means the making up of the knitted fabrics in suitable form for the market, and in the woolen-and-worsted-cloth industry, where the finishing department includes some processes corresponding to those performed in a cotton-cloth room, together with such additional processes as are necessary to prepare the fabric for the market. However, in the cotton trade, it is becoming more and more common for all purely converting processes, which change the appearance of the fabric, to be conducted in a separate establishment, known separately as a bleachery, dye works, print works, or collectively as converting, or finishing, works.

The cloth-room processes listed here have as their object merely the changing of the form of the fabric from that in which it leaves the loom to a suitable one for shipment, and a slight or superficial cleaning of the cloth to make it presentable to the buyer, together with the necessary inspection and baling.

It is in comparatively few cloth rooms that all the processes listed are conducted, since but very few of them are absolutely necessary. The adoption of some or all of the processes depends on: (1) the fabrics that are to be treated; (2) the differences of opinion among millmen as to what is a suitable treatment even for the same fabric, and (3) the policy of the management either in the direction of avoiding all unnecessary processes, for the sake of economy, or of incurring additional expense in the equipment of the mill and in the operation of the cloth room, for the sake of producing the best quality.

3. The equipment and the operation of the cloth room cannot receive too much attention; in too many mills it is given but little consideration. In the designing or the equipment of the mill, very frequently any available space is utilized for the cloth room, while after the mill is in operation,

so long as the goods are inspected and baled, and the room is operated at a minimum expense, it receives no further attention. As a matter of fact, the proper equipment and operation of the cloth room is of vital importance to the successful running of the mill. The construction and location of the cloth room should be of the best, its equipment the most suitable for the fabrics being manufactured, and the arrangement of the machinery such as will enable the cloth to be treated with the least amount of handling and the greatest economy. The machines used should be so selected, set, and operated as to effect an improvement in the cloth between its leaving the loom and being packed into bales, that will far more than compensate for the comparatively small expense per yard involved. This will increase the reputation of the mill for producing well-made, well-classified, and well-finished fabrics, and will result ultimately in increased prices or preference when orders are being placed. Careful and constant attention to this department cannot fail to result in creating in the mind of the wholesale or retail buyer, the commission agent or the converter, those favorable first impressions of the goods that are so desirable, and in preventing the unfavorable impressions that must be produced by badly finished, badly inspected fabrics, made up untidily or irregularly, either in the piece or the bale.

4. In case a mill is sufficiently large to justify the expense, a cloth room should be located independently of the main building, preferably immediately between the weave room and the storehouse for baled goods and on the same level as these. It should be connected both with the weave room and with the storehouse by passages and should be of fireproof construction.

Where the weave room, the cloth room, and the passage between are all on one level, or approximately so, the cloth may be conveyed directly from the former room to the latter by means of trucks running on rails. When the weave room is situated above the cloth room, the cloth may be dropped into the cloth room by means of inclined chutes, while in

case the cloth room is at a higher elevation than the weave room, some mills adopt an endless belt, usually of rubber, that travels at a slow speed and has lags attached at short intervals, to carry the cuts of cloth up to the cloth room. In the case of the storehouse, it is important that the floor should be of such a height above the ground as to afford facilities for loading the bales of goods into railroad cars or on to trucks without raising them, and for this reason it is not always advisable to have the storeroom floor on the same level as the cloth room; but there should not be sufficient difference in the heights of the floors to prevent the bales being trucked from the cloth room to the storeroom on an incline.

One of the most important functions of a cloth room is the inspection of all the cloth manufactured by the mill, so as to ascertain imperfections that necessitate the classification of any pieces as *seconds*. In order that the persons inspecting the cloth may perform their work to the best advantage, the light should be of the best and should come from the best possible direction. It is desirable that this light should come from the roof; a good type is a saw-tooth roof taking the light from the north side, or if this is impracticable, a monitor roof is desirable. In case it is impossible to have either, the cloth room should be so located as to enable the light to be taken from the north side, where the inspection tables should be placed. The artificial light supplied should also be ample and suitable for use when daylight is not available.

The cloth room should be suitably constructed to reduce the risk of fire to a minimum, should be provided with fire-prevention apparatus, be well ventilated, and suitably heated. As many of the machines required are of heavy construction and others have intermittent motions that produce considerable vibration, the floor of the room should be of heavy construction. There should also be below it a well ventilated space, such as a low story or a basement, to provide against dampness in the floor. If this is impossible, the cloth room should be provided with a sufficient number

of slatted platforms on which cloth can be stored above the level of the floor. These platforms are divided by vertical slatted partitions into bins for the storage of different styles of cloth, after they have been folded and examined, until a sufficient number of cuts is collected to form a bale.

The arrangement of the machinery in the cloth room should be such as to reduce to a minimum the distances between the points where the cloth must be handled, always bearing in mind the necessity for adequate light at those tables or machines where inspection takes place.

Cloth rooms should be kept as clean as possible. If the condition of the room, as regards cleanliness, is not carefully considered and if dust and dirt are allowed to collect, it is evident that the objects of a large part of the work will be defeated by a simple matter that could be easily remedied by a little extra care and attention to details. For the purpose of keeping the cloth free from dust and dirt, the dust should be removed from the machines by means of a system of ducts and strong blowers or fans connected to the different machines.

#### CLOTH CHECKING

5. During the process of weaving, the cloth is wound around a roll on the loom until a certain length has been obtained, when it is severed from selvage to selvage and the roll on which it is wound taken out, leaving the cloth in a compactly rolled condition, in which form it is taken to the cloth room. What is known as a **cut** of cotton cloth is that length into which the cloth is finally cut and delivered to the dry-goods store or other ultimate purchaser. The length of a cut is usually about 50 yards, and the completion of each cut is indicated by means of a cut mark placed on the warp. Although the cloth is sometimes removed from the loom when a cut has been completed, it is more common to continue weaving until two cuts have been made; this is known as a *double cut*. In some cases, three, four, or more cuts are woven before the cloth is removed from the loom. The rolls of cloth are usually collected by an operative

detailed for that purpose, piled on a truck, and taken to the cloth room.

Cuts are also often spoken of as *pieces*; for example, it is occasionally found that the daily report of the weave room refers to so many pieces having been delivered to the cloth room. While the use of the word piece in this connection is to some extent justified by custom, it will not be used in this sense here; a piece will be considered as any continuous length of fabric without a seam, and the word *cut* will be used where the length of cloth between the cut marks is meant. The word *bolt* is also sometimes used to indicate a cut of cloth; for example, a bolt of gingham. The term *style* is used to describe a certain kind of cloth as determined by the weave, the weight per yard, the yarns, or any distinctive features in construction.

**6.** Different mills adopt different times for sending the cloth from the weave room to the cloth room, since this of course depends to a great extent on the size of the mill and the number of looms in operation; but it is always best to have a definite time set for this work, as by this means the operators in both rooms who have this in charge can arrange their other work to the best advantage. In the weave room, a record is kept of the number of cuts woven during each day, and if the room is running on more than one style of goods, the different styles are also designated, together with the number of pieces of each style woven. A duplicate of this report is sent to the cloth room, and the first duty of the overseer or second hand of this room when handling any newly arrived lot of cloth is to see that the weave-room report is carefully checked by means of the cloth received. This assures the discovery of any error that may have been made when booking the cloth in the weave room, and also makes it reasonably certain that no piece has been lost while the cloth has been passing from one room to the other. In some mills, it is customary for the list to be sent from the weave room in duplicate and one copy returned to the boss weaver by the overseer of the cloth room, either marked



correct or with any discrepancy between the amount called for by the list and that received in the cloth room indicated. This gives the boss weaver an opportunity of having the error rectified immediately. As different styles of goods are handled differently in the cloth room, and as a favorable opportunity is given, when checking the cloth received, for placing all the pieces that are to be handled alike in a pile by themselves, this should be done then, after which they can readily be taken to the different machines through which they are to pass. It is important that these piles of cloth from the weave room should not be allowed to accumulate, but should be opened, handled, and examined within a reasonable time after they arrive in the cloth room, for they may contain faults that should be discovered and reported to the boss weaver as soon as possible, especially in cases where the faults are those caused by defects in the loom, which should be remedied promptly to prevent the weaving of more cloth that will contain the same fault.

---

## SEWING AND ROLLING

---

### SEWING-AND-ROLLING MACHINES

7. It is more convenient and economical at some of the machines used in a cloth room to handle the cloth in a long continuous sheet, rather than in separate pieces. In some of these machines the cloth follows a path over and under certain brushes, rolls, shears, etc., through which it is difficult to thread the piece of cloth, and if this threading had to take place each time that a cut was run through, much time would be wasted and the production of the machine greatly reduced. Even in machines where the threading of the new piece through the machine would not occupy much time, the frequent stoppages at the ends of the cuts would reduce the production and increase the labor cost. If cuts of cloth 50 yards in length were passed through any of these machines one at a time, the greater part of the attendant's time would be devoted to stopping the machine after one

cut had run through and getting it ready to run another one. It is to avoid this loss of time that it has become customary to stitch the ends of consecutive pieces together and wind a number of them into one large roll, since by this means a much larger number of yards can be run at one time, without having to stop in order to start a new piece. As many of the later machines employed in a cloth room have a capacity of between 25,000 and 35,000 yards of cloth per day, if operated continuously, and as these machines are somewhat expensive to install, it is desirable to have as great a length as possible pass through each machine per day. It is also desirable to avoid any imperfect method of connecting the ends of cloth at the machine in question, which might result in damage to the machine or cloth or both. The sewing machine, therefore, has been introduced, and is widely used in cloth rooms for the purpose of neatly connecting the ends of pieces of cloth by means of a straight row of stitches extending from one side to the other, usually of the style known as a *continuous chain stitch*, and so arranged that the thread may be easily removed after it has served its purpose.

As the ends of the pieces are sewed together, some means must be provided for disposing of the cuts after they are attached to one another; this is generally done by winding them on a roll until a continuous length of as much as 1,000 yards or even more is obtained. The roll is then removed to the next machine through which the cloth is to pass, or in some cases is shipped in the roll to the bleachery or other converting establishment.

8. The two processes of sewing and rolling are generally performed in one machine, which is therefore called a **sewing-and-rolling machine**. Sometimes it is called the *opening-winding-and-sewing machine*, from the fact of its opening the small rolls of cloth that are taken from the loom and rewinding them into larger rolls, as well as sewing the ends together. The construction of the machine is such that after a piece of cloth is wound on the roll, the winding

arrangement is stopped until the end of a second piece is sewed to the end of the first piece, after which the sewing mechanism is stopped and the winding arrangement started

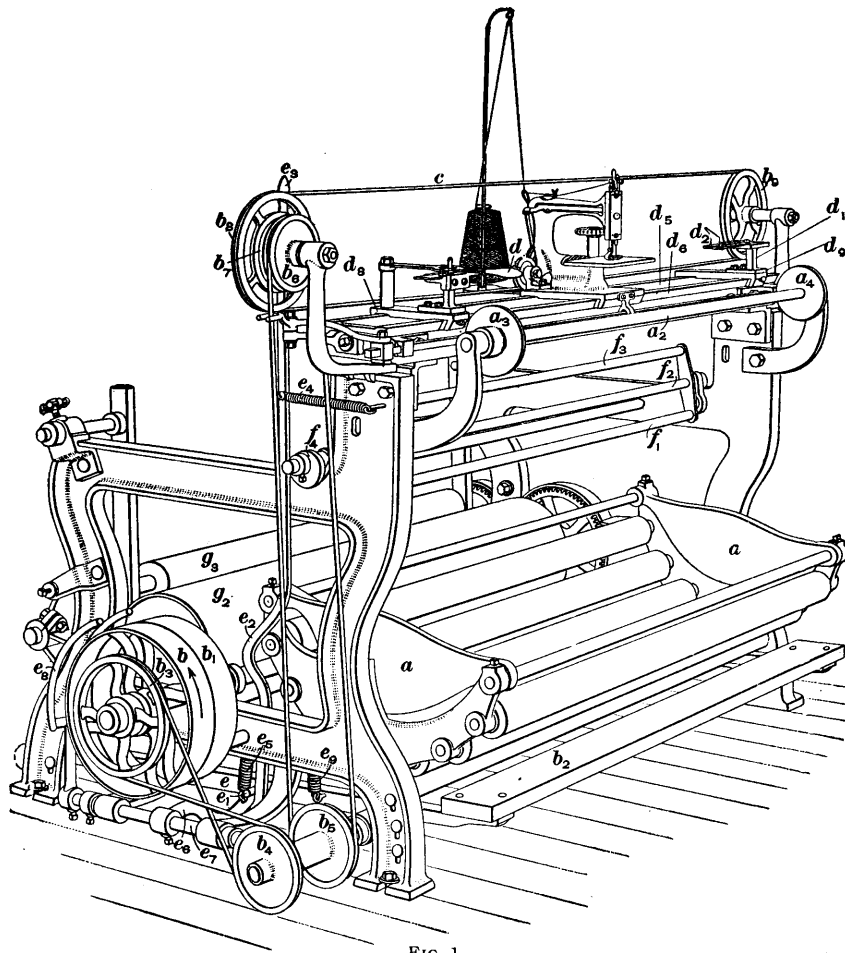

FIG. 1

and continued in action until the second piece is wound on the roll; winding is then discontinued and stitching repeated so as to attach a third piece of cloth to the end of the second, and so on. From the fact that the cloth is held stationary

during stitching, the ends being attached to and distended between steel pins, while the sewing machine travels along a track and inserts the thread that forms the chain stitch, this style of sewing machine is spoken of as the *railway sewing machine*. The seam should occur as near the edge of the piece of cloth as is possible, in order to reduce to a minimum the amount of waste cloth and the extra thickness where the joining occurs; this is desirable so as to offer as little obstruction as possible in passing through succeeding machines. The seam should not be so near the edge, however, that there will be danger of the cloth raveling. From 1 to 2 inches is usually left between the edge of the cloth and the seam, although this distance may be increased.

The sewing-and-rolling machine is almost always used in a cotton cloth room where the cloth has to be brushed, sheared, or calendered afterwards. The cloth passes to the sewing-and-rolling machine immediately after being checked, while still in the roll in which it left the loom, consisting of one, two, or more cuts, all in one piece.

**9. Rolling Mechanism.**—A view of a sewing-and-rolling machine is shown in Fig. 1, while a cross-section through the machine is shown in Fig. 2. The cuts of cloth are placed, one at a time, in the cradle *a* at the front of the machine and the end passed through until it reaches the back of the machine, where it is wound on a wooden roll *g*. The bottom of the cradle consists of wooden rolls, which revolve easily and facilitate the unrolling of the cloth. A cut of cloth is shown at *a*, Fig. 2, and the path that it follows indicated by the full lines. From the cradle, the cloth passes upwards and over the rod *a*, thence over *f*<sub>1</sub>, under *f*<sub>2</sub>, over *f*<sub>3</sub>, under the cylinder *g*, and thence to the roll *g*. In addition to the cylinder *g*, another cylinder *g* is in contact with the cloth that is being wound on the roll *g*. Both these cylinders are covered with sandpaper so as to provide them with a rough surface and enable them to grip the cloth sufficiently to draw it from the cradle *a* through the machine. The rods *a*, *f*<sub>1</sub>, *f*<sub>2</sub>, *f*<sub>3</sub>, not only guide the cloth, but assist in straightening it

out and producing a certain amount of drag to keep it tightly stretched.

The rods  $f_1, f_2, f_3$  also form part of an automatic stop-motion to stop the machine when each piece of cloth has been run through and a new stitching operation is necessary. The cam  $f_4$ , Fig. 1, is on the end of shaft  $f_2$ , on which the

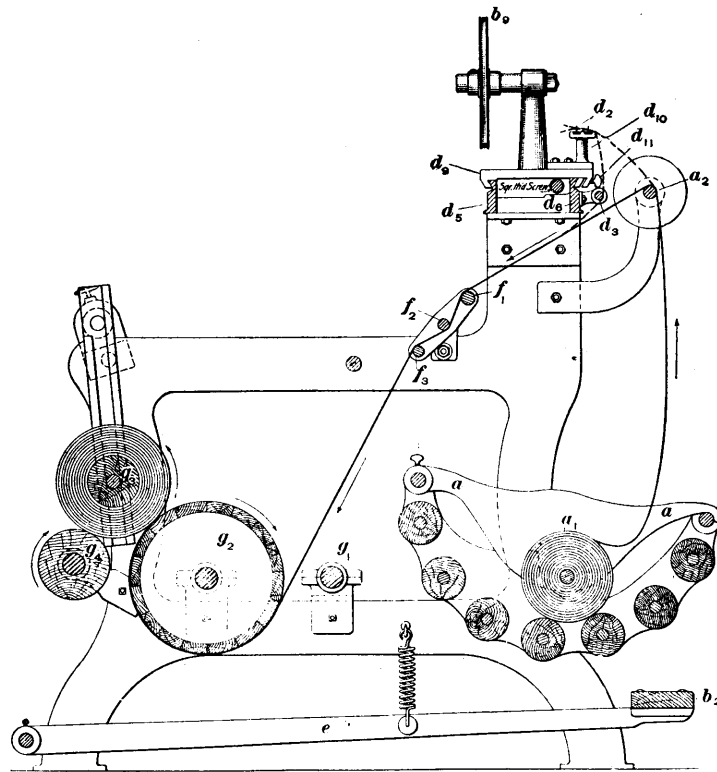

FIG. 2

tension bars  $f_1, f_2$  are held by arms. This shaft rotates freely in its bearings. The tension rods are weighted on one side so that  $f_1$  is heavier than  $f_2$ . Their natural position, which is assumed when there is no tension on the cloth passing through the machine and the last end of the piece is slack, is shown in Fig. 1, where  $f_1$  is at the bottom. The position of

the rods when the cloth is passing through the machine and is subject to tension is shown in Fig. 2, where  $f_1$  has been moved upwards to the right and  $f_2$  depressed to the left. This position is maintained until the *tail-end* of the piece approaches and the tension on the cloth slackens, which allows the rod  $f_1$  to return, thus throwing the cam  $f_3$  on the shaft  $f_2$  against the stop-lever  $e_2$  and, as the latter is moved by the cam, shipping the driving belt from the tight pulley  $b_1$  to the loose pulley  $b$ . At the same time a brake is applied to a brake pulley, on the shaft  $g_1$ , Fig. 2, and the winding mechanism is stopped. The brake and brake pulley are not shown in the views given, but are situated behind the pulley  $b_1$ , Fig. 1. In practice, this device is frequently disconnected, since the operator is generally in constant attendance on the machine and stops the rolling mechanism by means of the stop-lever or the foot-lever  $b_2$  at the bottom.

During the time that the cloth is being wound on the roll  $g$ , at the back of the machine, the cylinders  $g_2, g_3$  receive their motion from a gear on the end of the shaft that carries the tight and loose pulleys  $b_1, b$ , Fig. 1, the belt being on the tight pulley during this operation. The belt is shifted from the loose pulley  $b$  to the tight pulley  $b_1$  by the shipper fork  $e_s$ , which is controlled by a shaft  $e_1$ , to which is setscrewed an arm  $e_2$ , the other end of which is under an arm  $e$  controlled by the foot-lever  $b_2$ . The inner end of  $e_2$  is drawn up against the arm  $e$  by means of a spring  $e_3$ . When it is desired to ship the belt from the loose pulley  $b$  to the tight pulley  $b_1$ , the operator presses down the foot-lever  $b_2$ , which lowers the arm  $e$  together with the inner end of the arm  $e_2$ , turns the shaft  $e_1$ , and throws the shipper fork  $e_s$  in toward the machine, thus moving the belt from the loose pulley  $b$  to the tight pulley  $b_1$ . The arm  $e$  carries a projecting pin  $e_4$  that, when the foot-lever  $b_2$  is pressed down, engages with a notch in the lever  $e_2$  and thus holds the belt on the tight pulley.

In case it is desired to ship the belt from the tight to the loose pulley other than by the automatic device described, the handle  $e_5$  on the lever  $e_2$  is pushed toward the back of the machine, which withdraws the lower end of the lever  $e_2$  from

above the pin  $e$ , and allows the spring  $e_s$  to draw up the arm  $e$ , thus raising the foot-lever  $b_s$ . This allows the arm  $e_s$  to be drawn up at the same time by the spring  $e_s$  that tends to keep the inner end of  $e_s$  pressed up against  $e$ . The lifting of the arm  $e_s$  gives sufficient movement to the shaft  $e_r$  to throw the belt from the tight to the loose pulley. The grooved pulley  $b_s$  is attached to the loose pulley  $b$  and connected by a band to the pulley  $b_s$ , which is on the same sleeve as  $b_s$ , which is connected by a band to the grooved pulley  $b_s$ . Thus, when the driving belt is on the loose pulley  $b$ , the pulley  $b_s$  imparts motion to the pulley  $b_s$ .

**10. Stitching Mechanism.**—When the cut of cloth that is placed in the cradle  $a$  has been entirely unwound, the end is attached to the pins  $d_1$ , Fig. 3,  $d_2$ , Fig. 1, at the ends of the machine; a new cut is then placed in the cradle  $a$  and the end of this cut also fastened to the pins  $d_1, d_2$ . The position of the two ends that are to be stitched together is shown by the dotted lines in Fig. 2.

Preparatory to stitching the two ends of cloth together, the cloth is stretched by means of the handle  $d$ , Figs. 1 and 3. A pin passes through the rod to which this handle is attached and is connected to the slide on which the pins  $d_1$  are secured. After the cloth has been attached to the pins, the handle  $d$  is moved to the left until the arm rests in the notch shown, where it is secured until the stitching operation is completed, when it is raised out of the notch and moved to the right, in order thus to release the cloth. This stretches the cloth while it is being stitched, so that no wrinkles will be formed and also so that when released the cloth will not be narrower at the seam than elsewhere.

**11.** The action of the sewing mechanism is shown in Fig. 3. Just before the stitching action takes place, the driving belt is on the loose pulley and is imparting motion to the pulley  $b_s$  by means of the pulleys  $b_s, b_s, b_s$ , as shown in Fig. 1. When the ends of the cuts have been placed on the pins and are in a suitable position to be stitched, the rod  $d_s$ , Fig. 3, is moved to the left, which throws the leather band from the

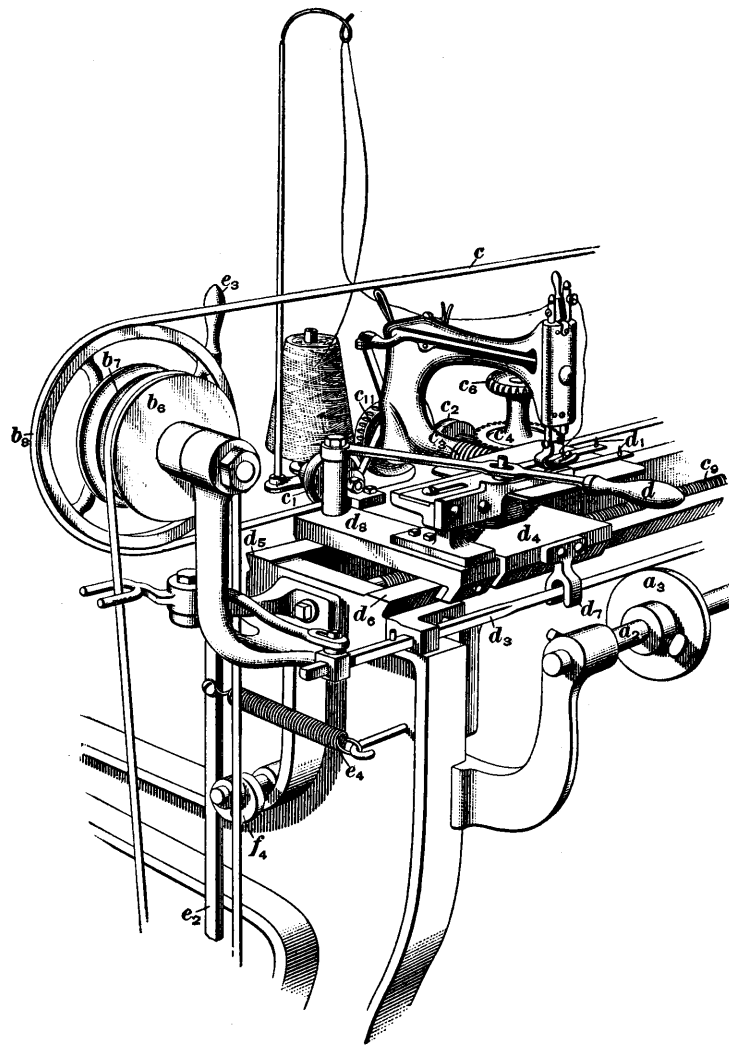

FIG. 3



loose pulley  $b$ , to the tight pulley  $b$ , and imparts motion to the pulley  $b$ , and the band  $c$ . This band passes around the two binder pulleys  $c_1$ ,  $c_2$ , and a pulley  $c_{11}$  on the sewing-machine head, and by this means starts the stitching mechanism in operation.

At the same time, the sewing-machine head travels from one side of the machine to the other. The mechanism that accomplishes this part of the operation is as follows: The

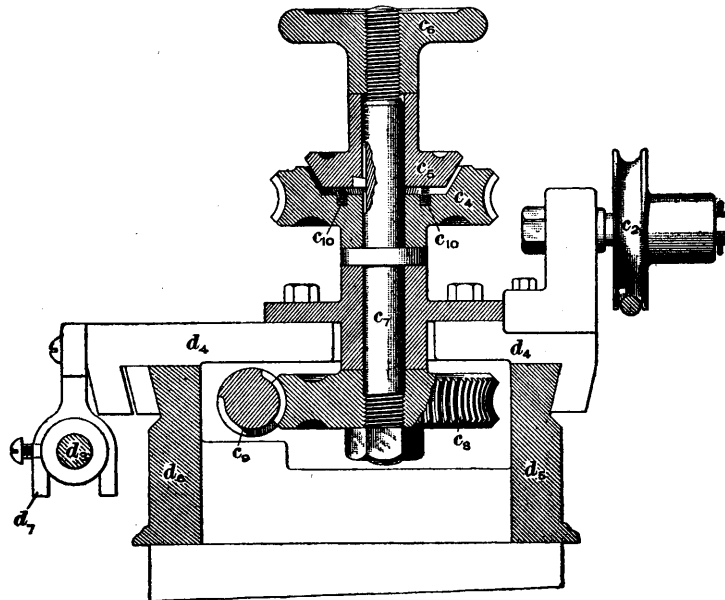

FIG. 4

pulley  $c_{11}$ , Fig. 3, that is attached to the sewing-machine head imparts motion to the worm  $c_3$ , which drives the worm-gear  $c_4$ . The worm-gear  $c_4$ , Fig. 4, forms a friction clutch with the casting  $c_8$ , which carries a key projecting into a keyway in the shaft  $c_7$ . At the upper end of this shaft is a thread on which is a hand wheel  $c_6$ , while at its lower end is a gear  $c_8$ , the teeth of which work in a stationary screw  $c_5$ . Before starting the stitching mechanism the hand wheel  $c_6$  is screwed down, which forces the casting  $c_8$  into contact with

the worm-gear  $c_1$ ; consequently, as the worm  $c_1$ , Fig. 3, imparts motion to the worm-gear  $c_2$ , Fig. 4, the shaft  $c_3$  is rotated, thus giving motion to the gear  $c_4$ . Since the screw  $c_5$  is stationary, the gear  $c_4$ , as it revolves, must necessarily receive a horizontal motion. It is by this means that the sewing-machine head is moved automatically from one side of the machine to the other during the stitching operation.

The plate  $d_1$  on which the sewing-machine head rests, slides on the supports  $d_2$ ,  $d_3$  and carries a projection  $d_4$ , shown in Figs. 3 and 4, which, when the head has traveled the full width of the cloth, comes in contact with a casting setscrewed to the rod  $d_5$ ; this moves the rod  $d_5$  to the right and shifts the band from the tight pulley  $b_1$  to the loose pulley  $b_2$ , thus stopping automatically the stitching mechanism when the seam has been completed. To move the stitching mechanism back to its original position the hand wheel  $c_6$ , Fig. 4, is unscrewed, which allows the springs  $c_7$  to force the casting  $c_8$  out of contact with the worm-gear  $c_4$  and breaks the connection between this gear and the shaft  $c_3$ . When the parts are in this position, the plate  $d_1$ , Fig. 3, together with the different parts of its supports, may be moved by hand to any desired position.

**12.** After the two ends have been stitched, they are removed from the pins  $d_1$ ,  $d_2$  and are allowed to fall between the rods  $a_1$ ,  $d_3$ , Fig. 2. The rolling mechanism is then set in operation by pressing down the foot-lever  $b_3$ , when the second cut of cloth is unrolled and rewound on the roll at the back of the machine. This operation is repeated with a sufficient number of cuts to form one large roll, which should be made large enough to facilitate the operation at the future machines, but not so large that it cannot be readily handled. Rolls are ordinarily made from 28 inches to 32 inches in diameter and contain from 800 yards to 1,200 yards of cloth.

**13.** The plate  $d_1$ , Fig. 3, to which the supports for the handle  $d$ , and the pins  $d_1$  are attached, is setscrewed to the supports  $d_2$ ,  $d_3$ , and does not move during the stitching operation.

The plate  $d_1$  is not attached to the plate  $d_2$ , although in Fig. 3 the latter is shown close to the former, as the sewing machine is there represented in its initial, or starting, position with the presser foot ready to pass between the pins  $d_1$  as the plate  $d_2$  and sewing machine start on their movement to the right. On the other side of the machine is a corresponding plate  $d_3$ , Figs. 1 and 2, carrying a pillar  $d_4$  supporting the pins  $d_5$ . The plate  $d_3$  is capable of sliding on the supports  $d_6$ ,  $d_7$ , but does not move during the stitching operation, being secured to the supports by means of a thumbscrew  $d_{11}$ , Fig. 2.

The guide plates  $a_3$ ,  $a_4$  shown attached to the rod  $a_2$  in Fig. 1, are secured to the rod by thumbscrews in such a position that they serve to guide the cloth correctly while it is being wound on the roll at the back of the machine, and also in suitable relative position to the pins  $d_1$ ,  $d_2$ . It is not customary to change the positions of the plate  $d_3$ , the pins  $d_1$ , and plate  $a_3$  except in extreme cases. When it is desired to make adjustments for different widths of cloth, the thumbscrew  $d_{11}$ , Fig. 2, is loosened and the plate  $d_3$  moved inwards or outwards to bring the pins  $d_5$  into the desired position, after which the thumbscrew is again secured. At the same time the guide plate  $a_4$  attached to the rod  $a_2$ , Fig. 1, is adjusted.

**14.** The sewing-and-rolling machine that has been described occupies a floor space of about 7 feet by 4 feet. The driving pulleys are 12 inches by  $2\frac{1}{2}$  inches, and are usually operated at a speed of 320 revolutions per minute. When operated at its full capacity, it can sew and wind in a day from 500 to 600 cuts, averaging 50 yards in length.

**15.** In some cloth rooms, the sewing machine is independent of the rolling attachment. In case a stationary machine is desired, that portion of the machine shown in the upper part of Fig. 1 is mounted on high stands resting on the floor and is driven by hand or by power as desired. Another arrangement when the sewing attachment is required to be used in connection with some machine,

other than a rolling machine, is to secure the upper portion of the mechanism shown in Fig. 1 to short stands suitable for attachment to any machine desired.

#### PORTABLE SEWING MACHINES

**16.** In many cases, it is necessary to stitch the ends of two pieces of cloth together in some part of the cloth room where it is more convenient to take the sewing machine to the cloth than to bring the cloth to the machine. This is the case when the stitches that bind the ends of two pieces

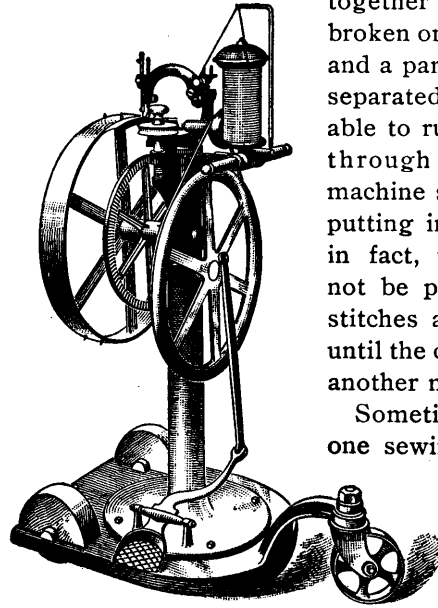

FIG. 5

together in a large roll have been broken or cut, through some cause, and a part at least of the two ends separated. It would be undesirable to run the entire roll of cloth through the sewing-and-rolling machine simply for the purpose of putting in these few stitches, and, in fact, in many cases it would not be possible, as the defective stitches are often not discovered until the cloth is being run through another machine.

Sometimes it is desirable to have one sewing machine available for use with several other machines; for example, when the cloth from a large roll has been run through a later machine and it is de-

sired to attach the end of a new roll to the tail-end of the one that has been run through. In such cases, a portable foot-power sewing machine, shown in Fig. 5, is used. This machine rests on wheels and consequently can be moved readily from one part of the room to another, as may be desired. In operation the ends of the two pieces of cloth

that are to be sewn together are attached by pins to a slowly rotating wheel. As the machine is operated by means of the treadle, this wheel feeds the cloth under the presser foot of the sewing attachment where the stitching is inserted. In other cases where the amount of available floor space is limited, the sewing machine is suspended from the ceiling of the room, and in still other cases where one sewing machine is required at various points in the room, the sewing mechanism is suspended from a track attached to the ceiling, so that it may be moved to different points in the room where it is required. In such cases, of course, the sewing is performed by hand power.

#### ROLLING MACHINES AND HAND SEWING

**17.** Many times, especially in the older cotton mills, machines are used for the same purpose as the sewing-and-rolling machine described, but constructed and operated without the sewing attachment. In general construction, they are similar to the machine shown in Fig. 1, although for special fabrics, such as those exceptionally wide and heavy, different styles of construction are adopted. The mechanism of the machine requires no description beyond that already given. With these machines, the ends of consecutive pieces of cloth are sewed together by hand, the operator using for this purpose a long, heavy needle with thin twine knotted at one end and longer than the width of the fabric. The tail-end of each piece is placed against the new end from another piece and the needle passed alternately through the cloth from one side to the other at intervals of about 2 inches. The knotted end of the twine remains at one edge of the cloth, while the operator ties another knot at the other edge after the thread has been passed through the cloth, so as to prevent its being drawn out in passing on to the roll or through a succeeding machine. This system is largely used in cloth rooms where consecutive pieces of cloth are sewed together temporarily, since it occupies less time and the thread can be easily drawn out later, but is not as satisfactory as machine sewing.

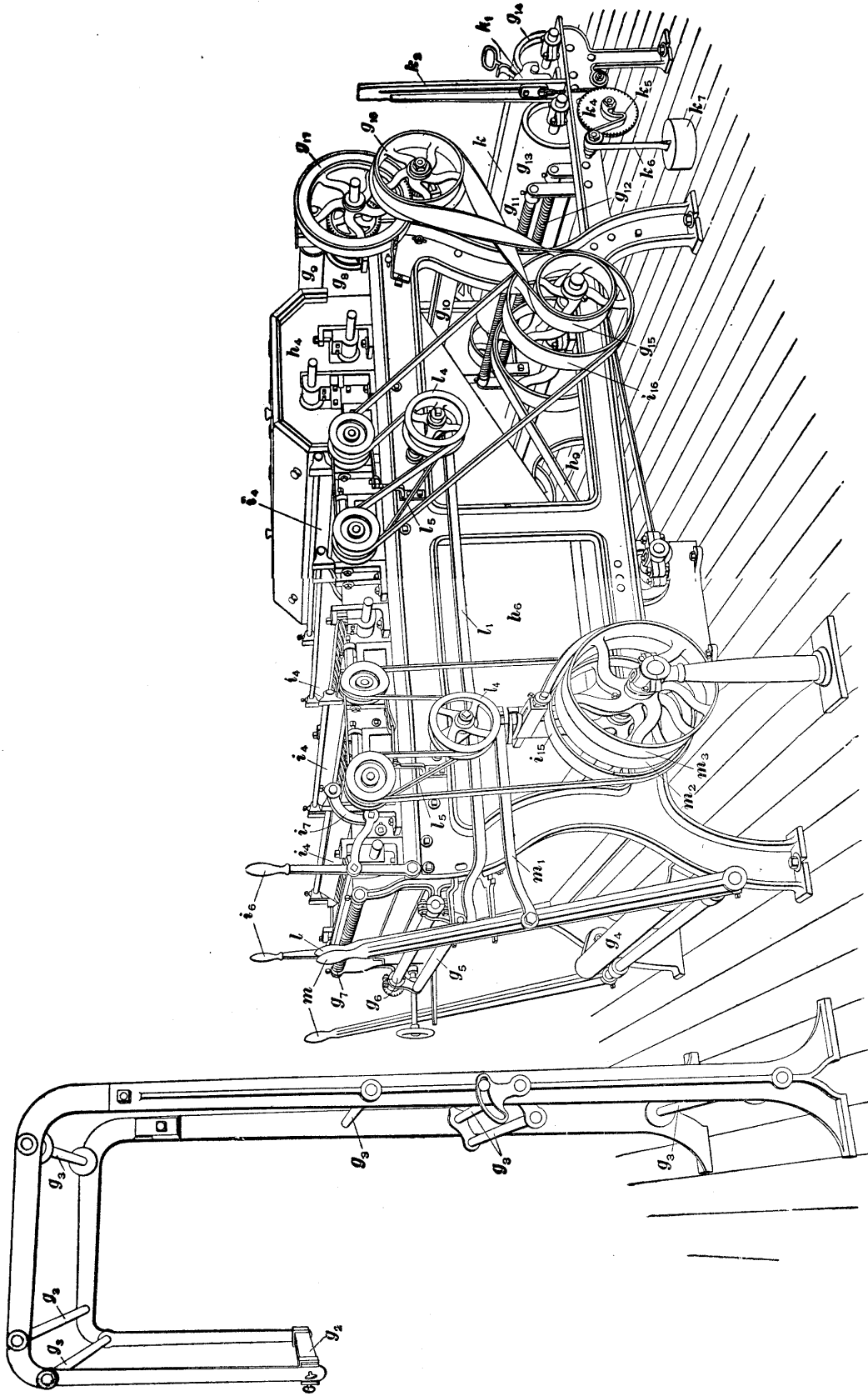

FIG. 6

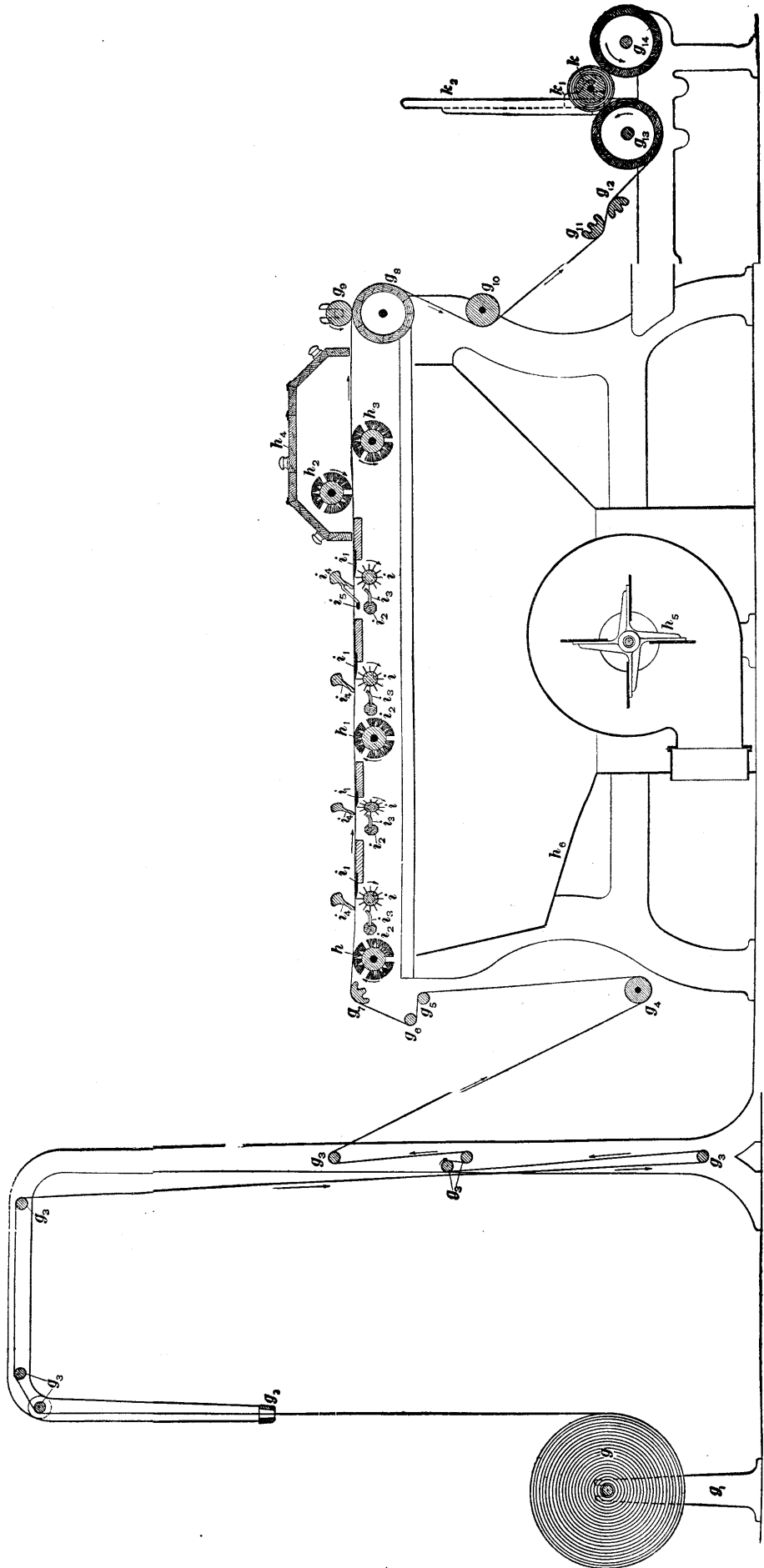

FIG. 7

ILL 9 500A

it, is spread out to its full width and passes into the machine perfectly free from wrinkles. This is accomplished by means of two series of flutes, one series slanting toward one end, and the other toward the other end of the bar, as shown in the illustration, with the result that as the cloth passes over the bar the tendency is to stretch it in its width.

In passing through the machine, the cloth is acted on by four brushes  $h, h_1, h_2, h_3$ , Fig. 7, three of which  $h, h_1, h_2$  operate on the face of the cloth, which is the under side in passing through the machine, and one  $h_3$  on the back of the cloth. Four *revolvers*  $i, i, i, i$ , in conjunction with their respective ledger blades  $i_1, i_1, i_1, i_1$ , shear the projecting fibers from the surface of the cloth. It is customary to have each revolver or each two revolvers preceded by a brush running in the same direction as the cloth, but at a greater speed; the brush thus serves to raise the fiber so that it can be readily cut from the surface of the cloth by the revolver and ledger blade. The brush  $h_3$  that comes in contact with the back of the cloth is simply for the purpose of removing loose threads, dust, bits of leaf, etc. from this side of the fabric. It is enclosed in a hood  $h_4$ , so as to prevent the flyings that it makes from passing into the air of the room in which the machine is placed. The brush  $h_3$  gives a final brushing to the face of the cloth, removing loose ends of yarn and fiber left by shearing and laying down smooth and in one direction those fibers forming a part of the cloth. The brushes  $h_1, h_2$ , which finally brush the fabric, run in the opposite direction to the cloth where they are in contact with it.

The fan, or blower,  $h_5$ , which is enclosed in a casing  $h_6$  so arranged as to enclose all the working parts of the machine, draws away all the flyings, fiber, and foreign matter removed from the cloth and discharges them, through a system of ducts, or flues, outside the mill. The amount of such matter removed in this way is considerable.

After passing through the machine, the cloth emerges between two rolls  $g, g$ , passes around a guide roll  $g_{10}$  under the bar  $g_{11}$ , over the bar  $g_{12}$ , both of which are constructed similar to the bar  $g$ , then under the roll  $g_1$  which



is covered with sandpaper, and finally is wound around the roll  $k$  by the roll  $g_{13}$  and an additional sandpaper-covered roll  $g_{14}$  that form what is known as the *rolling head*. The rolls  $g_8, g_9$  are positively driven and are the means by which the cloth is drawn through the machine, while the rolls  $g_{13}$  and  $g_{14}$ , also positively driven, take the cloth as fast as it is delivered and wind it into a roll.

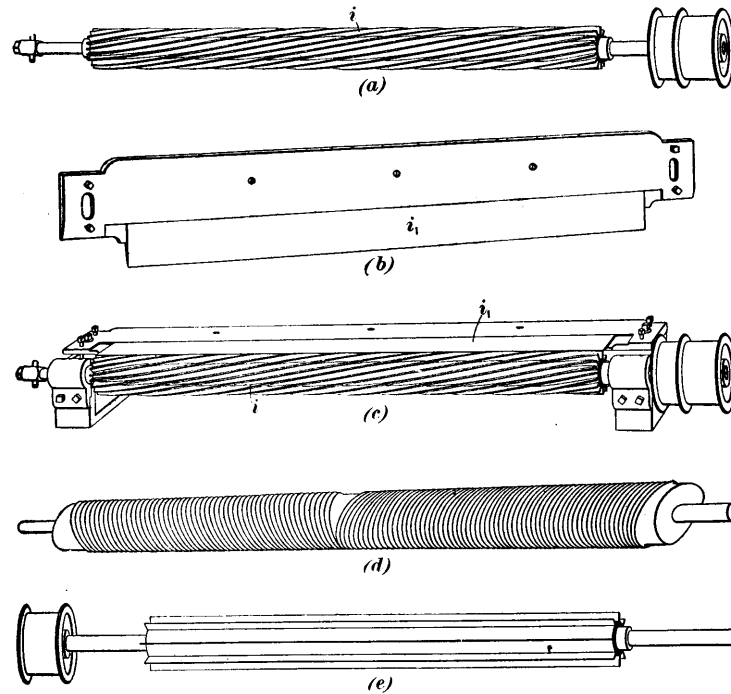

FIG. 8

19. The brushes of this machine are of ordinary construction and consist of a wooden barrel into which short, stiff bristles are inserted. Their only object is to clean the cloth of impurities and raise the fibers so that they may be readily cut by the revolvers and ledger blades.

20. Fig. 8 (a) shows the construction of a **revolver**, while Fig. 8 (b) shows the construction of a **ledger blade**.

The revolver has cutting blades arranged spirally on its surface so that as it revolves the projecting fibers of the cloth will be cut between them and the ledger blade, with which the cloth is in contact, in a manner similar to the action of a pair of scissors. Fig. 8 (c) shows a revolver and a ledger blade as mounted in the machine, with the ledger blade set lightly in contact with the blades of the revolver and its edge directly over the center of the revolver shaft. These parts together are known as a *set of blades*, or sometimes as a *shear*.

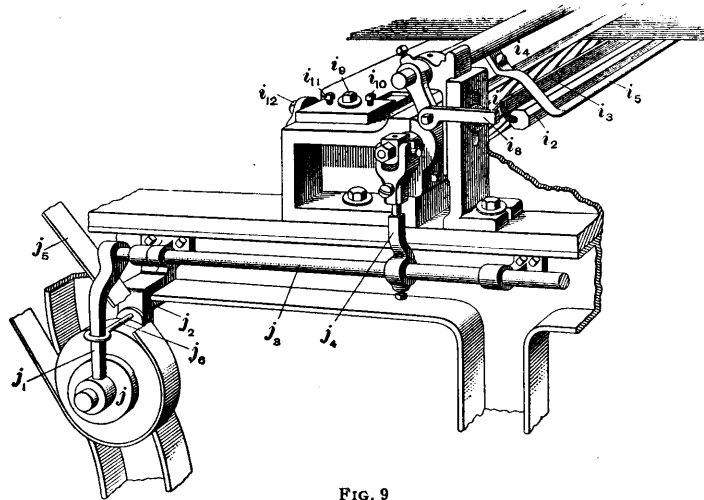

FIG. 9

The revolvers, in addition to having a rotary motion, also have a slight traversing motion, which not only aids them in shearing the cloth, but prevents uneven wear of the revolver or ledger blade. The method of imparting this traverse motion to a revolver is shown in Fig. 9. The revolver is supported at each end by stationary bearings, which hold it in the proper position with relation to the ledger blade, but still allow it to be moved laterally for a certain distance. This lateral, or traversing, movement of the revolver is obtained in the following manner: A rod  $j_5$  that is supported by brackets attached to the framework carries at one end an

arm  $j_1$  that is operated by a cam  $j$ , being held in contact with the cam by a spring  $j$ , acting through a rod  $j_1$ . As the cam revolves, the lower end of the arm  $j_1$  is caused to move in and out and consequently imparts a rocking motion to the rod  $j_1$ . Attached to the rod is an arm  $j_2$  that carries a forked casting, each arm of which contains a slot. Between the arms of this fork is a small casting that carries two pins, one on each side, that project into the slots in the fork. This latter casting is carried by the shaft of the revolver, and although when moved laterally it imparts the desired traversing motion to the revolver, it does not interfere with the rotation of the latter. Since the rod  $j_1$  receives a rocking motion it imparts a swinging motion to the forked casting, which in turn imparts the traversing motion to the revolver.

As each revolver is connected to the rod  $j_1$  in the same manner, as shown in Fig. 14, a traversing motion is consequently imparted to each revolver.

In order to maintain the necessary contact between the cloth and the ledger blades, cloth rests, or guides,  $i_1$ , Fig. 7, are placed in front of each revolver on the upper side of the cloth. Their function is simply to press down the cloth so that as it passes the shearing point it will be in perfect contact with the ledger blade and thus the fibers will be evenly trimmed. Slotted bars  $i_2$ , having a wick, or oil swab,  $i_3$ , inserted in them are so placed in front of each revolver that the swab rests on the cutting blades. These swabs should be well soaked in oil so that they will lubricate the cutting blades and prevent their *screaming*, which will occur if they are allowed to run dry against the ledger blades.

**21.** When the seams formed by stitching the ends of two cuts of cloth together are passed through the shearing-and-brushing machine it is necessary, in order to prevent cutting the cloth, to raise the cloth guides  $i_1$  so that the brushes  $h, h_1$  will lift the cloth away from the revolvers and ledger blades. Since there is no brush immediately in front of the last revolver, a lifter rod  $i_4$  is attached to the last cloth rest  $i_1$  so as to pass underneath the cloth at this point and

thus serve the same purpose. These guides are raised by means of two handles  $i_6$ , Fig. 6, either of which when operated raises a lever  $i_7$ , attached to the first cloth guide; and as all the other cloth guides are connected by a bar  $i_8$ , as shown in Fig. 14, this raises them all. This is done while the machine is in operation, the handle  $i_6$  being pulled forwards for a short time while the seam is passing through the machine.

The ledger blades may be set to the revolvers as shown in Fig. 10. The blade is bolted to the frame by a bolt  $i_9$ , and may be raised or lowered from the revolver by two adjusting

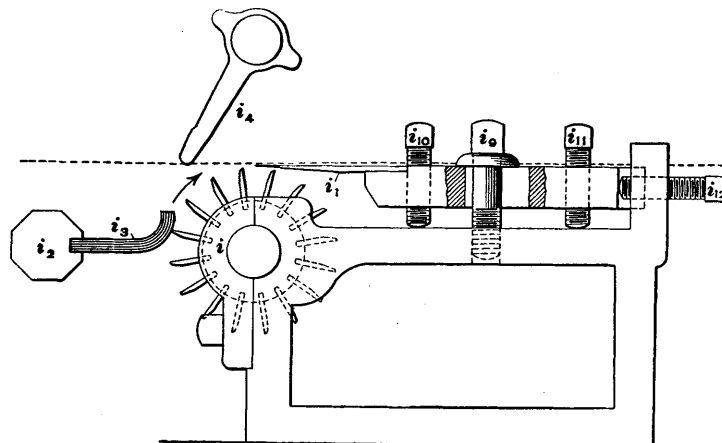

FIG. 10

screws  $i_{10}$ ,  $i_{11}$ ; a screw  $i_{12}$  enables it to be set forwards after it has been ground sufficiently to be shortened slightly. Fig. 10 shows only one end of a ledger blade, but the arrangement is the same for the other end and for all the blades.

Occasionally shears are arranged for the upper side of the cloth; when this is the case the arrangement is as shown in Fig. 11. The ledger blade in this case is adjusted by means of the screws  $i_{10}$ ,  $i_{11}$ ,  $i_{12}$ , and the oil swab  $i_4$  is placed over the revolver. A guard  $i_{13}$  is provided to press the cloth down and away from the revolver and ledger blade when seams are to be passed through the machine. This is

accomplished by the same handle  $i_6$ , Fig. 6, which when operated throws the guard  $i_3$  down under the revolver, as shown by the dotted lines in Fig. 11, and at the same time, by means of the connecting-rod  $i_{14}$ , lowers the cloth guide  $i_4$ , which in this case is placed underneath instead of over the cloth; the position of the cloth guide when it is lowered is also shown by dotted lines, while the corresponding positions of the cloth are shown by the two horizontal dot-and-dash lines.

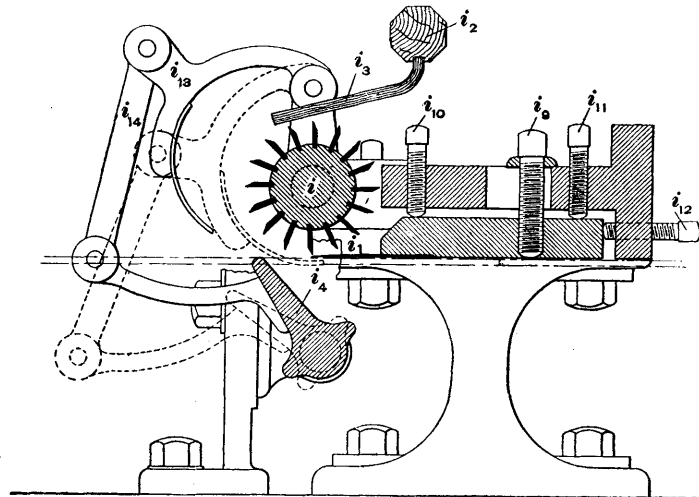

FIG. 11

**22.** In order to be sure that the cloth will not be cut when the seams are being passed through the machine, the driving belts of the revolvers are slackened and a friction is applied to them to check their rotary motion when this takes place. This is accomplished in the following manner: The belts that drive the revolvers pass around binder pulleys  $l_4$ , Fig. 12, that revolve on studs fastened in the castings  $l_2$ , which are pivoted at  $l_5$ . These castings are connected by a rod  $l_1$ , which is connected to a lever  $l$ , and also to friction bands  $l_6$  that pass around brake, or friction, pulleys on the shafts of the revolvers and are attached to brackets  $l_6$ . When the

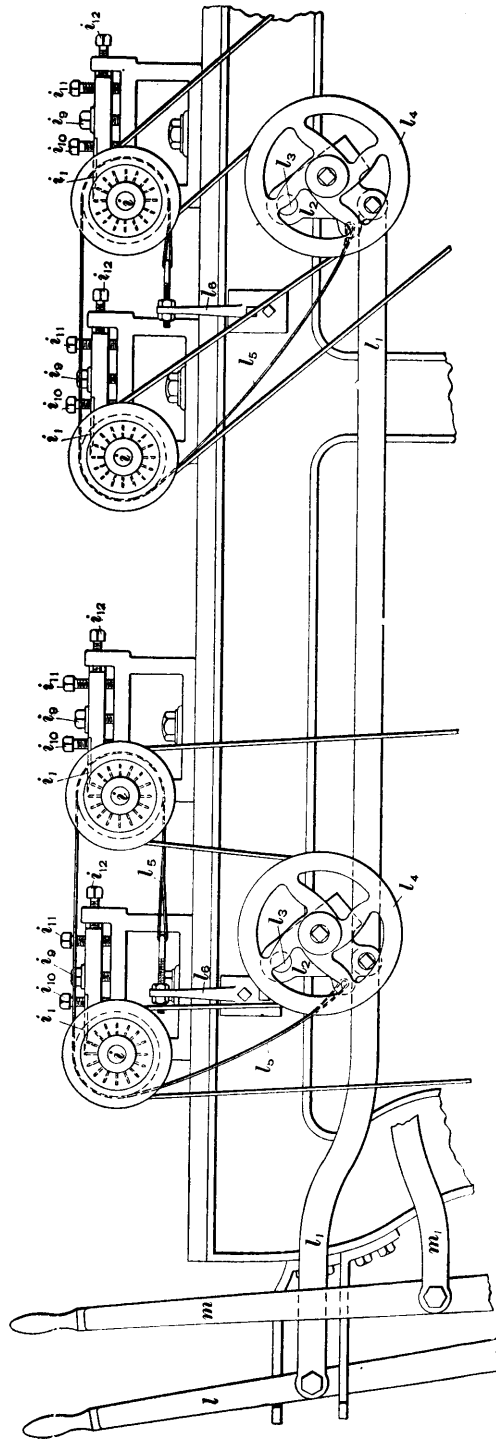

FIG. 12

handle  $l$  is forced forwards, the binder pulleys, in swinging about the center  $l_3$ , slacken the belts, and at the same time the steel friction bands  $l_4$  are tightened and the motion of the revolvers checked.

**23.** The construction of the rolling head is shown in Fig. 13. The cloth in being wound is wrapped about a roll  $k$ , the journals of which are in contact with castings  $k_1$ , that slide in slotted stands  $k_2$ . Motion is imparted to the cloth

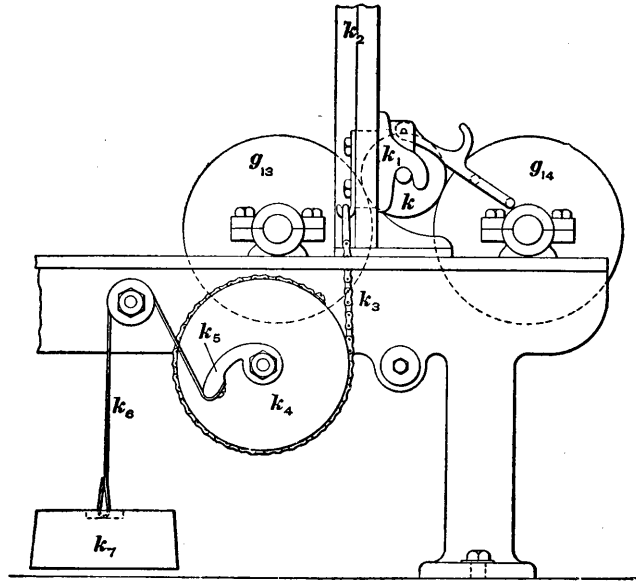

FIG. 13

by two sandpaper-covered rolls  $g_{13}, g_{14}$ . The chain  $k_3$ , attached to the casting  $k_1$ , is wrapped around a disk  $k_4$ , to which its other end is attached. Attached to a projecting wing  $k_5$ , cast in one piece with this disk is a strap  $k_6$  that supports a weight  $k_7$ . As the roll of cloth increases in diameter, the castings  $k_1$  are raised and the chain  $k_3$  imparts motion to the disk, which raises the weight  $k_7$ . As this proceeds, the strap  $k_6$  becomes wrapped around the smaller diameter on the wing  $k_5$ , so that the pressure on the journals of the roll  $k$

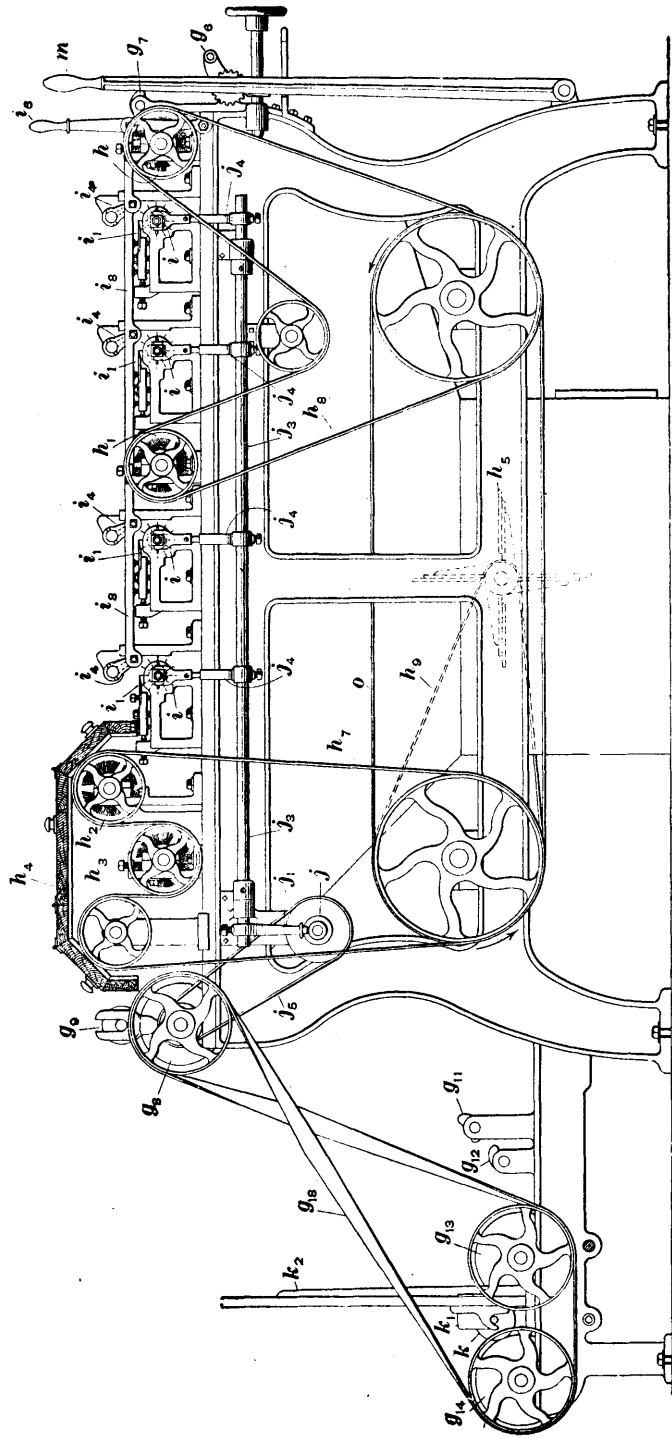

FIG. 14



on which the cloth is wrapped is decreased correspondingly as the diameter, and consequently the weight, of the roll of cloth increases.

**24.** The driving of the shearing-and-brushing machine is as follows, the references being to Figs. 6 and 14, the former of which shows the belts on one side, and the latter the belts on the other side of the machine: The motion of the machine is primarily controlled by two shipper levers  $m$ , either of which, through the rod  $m_1$ , controls the shipping of the driving belt on the tight and loose pulleys  $m_2$ ,  $m_3$ . The first two revolvers, as shown in Fig. 6, are driven by a belt from the pulley  $i_{1s}$  on the main shaft of the machine. The last two revolvers are driven by a belt from the pulley  $i_{1s}$  on a cross-shaft, to which motion is imparted by a belt  $o$ , Fig. 14. On the same shaft is a pulley that by means of a belt  $h_s$  drives the fan, or blower. A pulley  $g_{1s}$ , Fig. 6, on this shaft drives, with a cross-belt, a pulley  $g_{1s}$ , while a gear compounded with  $g_{1s}$  drives a gear  $g_{1r}$  that is attached to the shaft of the roll  $g_s$ . The roll  $g_s$  is driven by gears from the shaft of the roll  $g_s$ . On the opposite side of the machine the brushes are driven by belts  $h_7$ ,  $h_8$ , as shown in Fig. 14. The rolls  $g_{1s}$ ,  $g_{1s}$  are driven by a belt  $g_{1s}$  from a pulley on the shaft of the roll  $g_s$ . The cam  $j$  is also driven by a belt  $j$  from a pulley on this same shaft.

**25.** The machine represented in Fig. 6 is one of a large number of types of shearing-and-brushing machines. These machines differ very largely in construction:

1. They are made with from one to six sets of shears and from one to three brushes on one side of the cloth, usually the face side, in addition to the two finishing brushes—one on each side of the cloth. The number of shears and brushes on a machine depends on the finish required by a cloth, its condition, the material of which it is made, and the speed at which it is drawn through. Generally speaking, the coarser the cloth, the greater is the number of shears, etc. required, but some kinds of the finest cloth require a large number of shears and brushes. Where there is only

one shearing arrangement on one side of the cloth, there is usually one brush preceding it in addition to the two finishing brushes. Where there are two or more sets of shears on one side of the cloth, one brush precedes each set, or each two sets, of shears.

2. They may be constructed to shear and brush both sides of the cloth at the same time, with one or more sets of shears and brushes operating on the back of the cloth at the same time that others are operating on the face of the cloth, thus shearing and brushing both sides of the fabric by once running it through.

3. Card rolls may be added; these are wooden rolls covered with fillet card clothing, the teeth in which are somewhat straighter than those in ordinary card clothing; the rolls are run with the point of the teeth pointing backwards, in order to prevent forming any nap on the goods. They also are arranged on either one or both sides of the cloth and vary in number. A fuller description of them will be given in connection with the cotton brushing-and-calendering machine.

4. Emery rolls and beaters may be added; these are attached to the feed-end of the machine and are described in connection with the cotton brushing-and-calendering machine.

5. The rolling head may be replaced with a calender-rolling machine, by which the cloth is smoothed and pressed before being wound in a roll. This may be arranged for either cold rolling or hot calendering, with or without a steam moistening arrangement. This mechanism will be described later.

It will thus be seen that the differences in construction, caused by the variable number and arrangement of shears, brushes, and card rolls, and by the use or non-use of emery rolls, beaters, and hot or cold calender rolls, give an almost endless combination of mechanisms, resulting in hundreds of different arrangements of shearing-and-brushing machines; about fifty types are in regular use. The general principles, however, are here described, so that there should be no difficulty in thoroughly understanding the construction

and operation of any of these machines that may be met with in practice. The variable constructions prevent any definite information being given as to the dimensions of shearing-and-brushing machines, but for general guidance it may be stated that these machines vary in length from 8 feet to 12 feet; the width is generally about 7 feet in all machines. About 500 cuts per day is a good average production for a shearing-and-brushing machine.

---

#### SHEAR GRINDER

**26.** When the revolvers or ledger blades of shearing machines become dull, they are sharpened on a **shear grinder**. This is a machine of substantial construction carrying an iron cylinder that has a traverse of about 4 inches, and against which the revolvers or ledger blades are held. The cylinder is kept supplied with fine emery and oil for grinding purposes. When the grinder is used for sharpening the revolvers, they are held in a suitably adjusted stand and driven by chains and sprockets, so as continuously to bring their different parts against the grinding cylinder. When the ledger blades are being ground, a different arrangement of stand is applied to hold the blades in a suitable position, and they are pressed against the grinding roll by levers and weights.

---

#### COTTON BRUSHERS

**27.** The **cotton brusher** performs work similar to that of the shearing-and-brushing machine described, except that it has no shearing operation. It, too, is constructed in many different ways, with a varying number of brushes on each side of the goods, and in combination with other mechanisms for producing various results. Fig. 15 shows a section of one type of this machine that not only comprises a complete brushing machine proper, but also includes emery rolls, beaters, and card rolls, as well as a calender-rolling attachment. The framework *a* of the main machine rests on the floor of the room and is arranged with a level horizontal

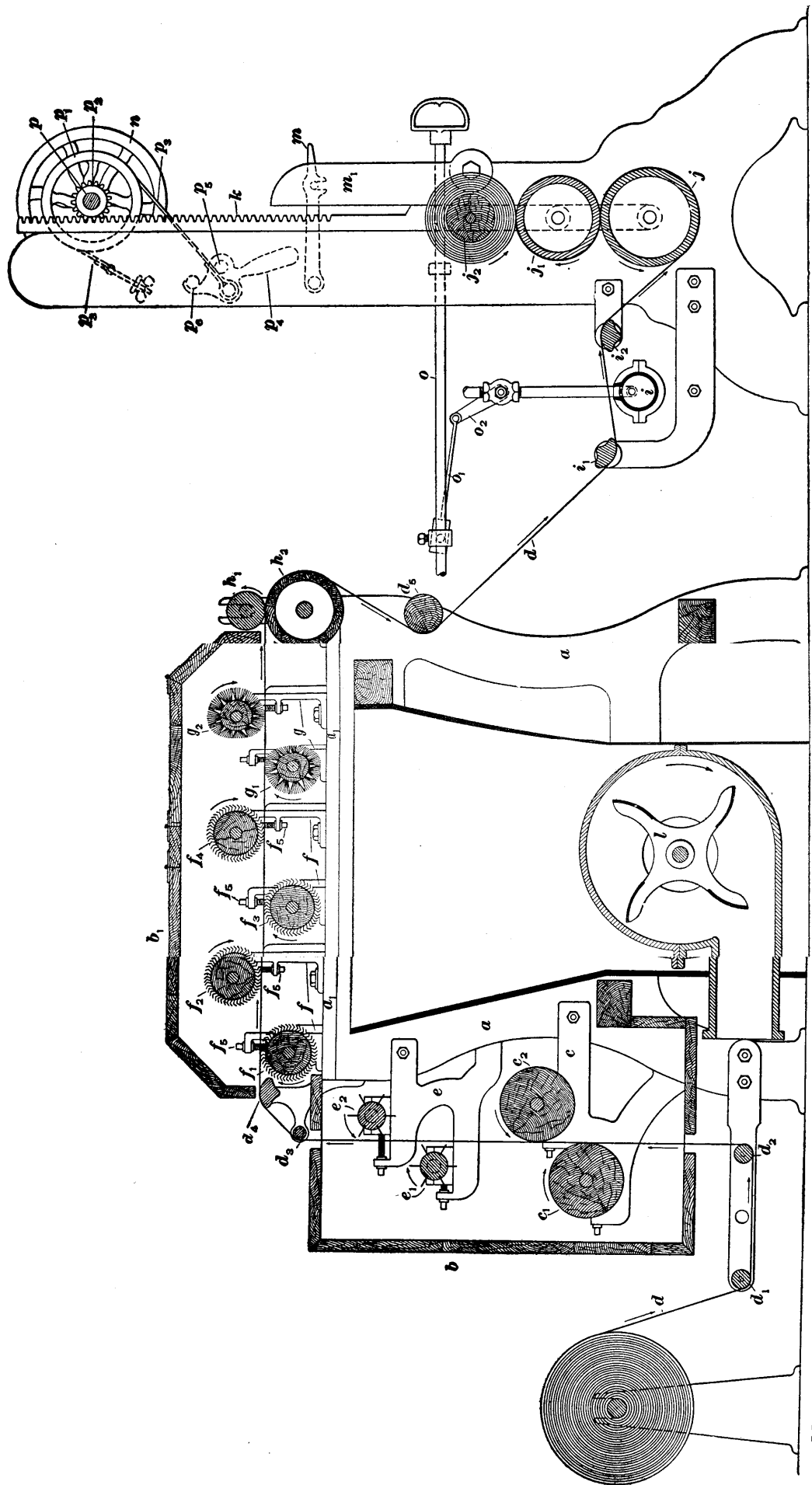

FIG. 15

ILT 9 500A

surface at the upper part  $a_1$ , on which rest brackets carrying the brushes, card rolls, and the rolls that draw the cloth through the machine. At the feed-end of the machine is attached a bracket  $c$  carrying in suitable adjustable bearings the emery rolls  $c_1, c_2$ , so arranged that one operates on the face of the cloth and the other on the back. Each emery roll consists of a wooden barrel covered spirally with a fillet of emery cloth secured at each end, or in some cases with a coating of coarse emery glued on to the surface of the roll.

**28.** The cloth  $d$  passes through the machine in the direction shown by the arrows, first under the guide rolls  $d_1, d_2$ , thence upwards and between the two emery rolls. These rolls revolve in the opposite direction to that in which the cloth is passing, and have a scraping action, which for the most part removes motes, leaf, and rough places projecting on each side of the fabric, those that are not removed being sufficiently loosened to facilitate their removal by the beaters, card rolls, or brushes of the machine. The beaters  $e_1, e_2$  are supported in adjustable bearings on a bracket  $e$  so that one operates on the face of the fabric and the other on the back. Fig. 8 ( $e$ ) represents one of these beaters removed from the machine. It has steel blades radiating from the barrel and set equal distances apart, each side of the edge of the blade forming a sharp corner. These beaters run in the opposite direction to that in which the cloth passes, and knock off the knots and nubs that in many cases cannot be removed by any other means, as well as loosen the dust and dirt so that it may be brushed off by the card rolls and bristle brushes.

The cloth continues its passage over a guide roll  $d_3$  and guide bar  $d_4$  and next comes under the action of four card rolls  $f_1, f_2, f_3, f_4$  supported from the framework by brackets  $l$  and adjustable by means of the setscrews  $f_5$ . The card rolls  $f_1, f_2$  operate on the under side of the cloth and  $f_3, f_4$  on the upper side. These rolls are covered with card fillet and run in the opposite direction to that in which the teeth point, thus avoiding the formation of a nap on the

cloth, but serving to remove motes, specks, etc. After passing between these rolls, the cloth is subjected to the action of two bristle brushes  $g_1, g_2$  mounted in adjustable bearings on brackets  $g$  that are set on the horizontal surfaces of the framework of the machine. These brushes are set with stiff bristles and correspond in their construction and operation to  $h_1, h_2$ , Fig. 7. The cloth then passes between the rolls  $h_1, h_2$ , which draw it through the machine. These rolls, in construction and operation, correspond to those shown at  $g_1, g_2$ , in Fig. 7, and are described in connection with the machine there illustrated.

29. The emery rolls and beaters are incased by the removable cover  $b$ , while the brushes and card rolls are covered by the upper cover  $b_1$ . Both of these covers are so constructed as to admit of their being partly removed, thus affording facilities for inspecting and cleaning the machine. An exhaust fan  $l$  is provided, which removes from the incased portion most of the lint, dust, and smaller particles of fibrous or foreign matter, delivering them into a flue or chamber arranged to receive them. The threads in many cases remain on the surface of the brushes or slightly embedded between the bristles and have to be removed at intervals—several times each day.

---

#### CALENDER-ROLLING MACHINE

30. The machine shown in Fig. 15 also differs from that shown in Fig. 6 in the treatment of the cloth after it leaves the machine proper. In the machine shown in Figs. 6 and 7, the cloth was simply rolled at a rolling head, but in the case of the machine shown in Fig. 15, an entirely separate mechanism is placed in front of the machine, known as a **calender-rolling machine**, the object of which is not only to form the cloth into a roll, but before doing so to pass it between heavy rolls for the purpose of smoothing out the goods. The cloth passes from the brusher under and partly around a guide roll  $d_1$ , thence under a guide bar  $i_1$  and over a second guide bar  $i_2$ , beneath which is placed

a hollow steam vapor cylinder  $i$ . This is connected to a steam pipe, and by means of perforations on its upper side allows a light vapor of steam to impinge on the cloth as it passes between the two guides  $i_1, i_2$ ; the flow of steam is very small and can be regulated as desired. The fabrics only require to be moistened sufficiently to aid the heavy calender rolls in smoothing out the cloth and to give it a softer finish and feel. The steam is admitted to the vapor cylinder through a cut-off valve so arranged that it shuts off the supply of steam entirely when the machine is stopped, thus preventing any excessively damp places in the fabrics. This is accomplished by connecting the lever  $o$ , that operates the valve to the shipper rod  $o$  by a rod  $o_1$ ; thus, as the shipper rod is operated to stop the machine, the steam is automatically cut off from the vapor cylinder  $i$ ; when the machine is started again the steam is admitted to it without further attention on the part of the operator.

**31.** After leaving the guide  $i$ , the cloth passes under and partly around the lower calender roll  $j$  and upwards and partly around the upper calender roll  $j_1$ , thence to the cloth roll  $j_2$ , around which it is wound. In passing between the rolls  $j, j_1$ , the cloth is subjected to a certain amount of pressure, since both rolls are of considerable weight, thus calendering or compressing the fabric and producing a smooth surface. These rolls may be driven at the same surface speed, in which case they have merely a compressive action; or, by the use of unequally sized gears, the upper roll may be driven slightly faster than the lower one, thus producing an ironing effect on the fabric and increasing the smoothing action of the rolls. The rolls  $j, j_1$  are hollow and fitted with stuffing-boxes, piping, and valves, so that steam may be admitted to the inside of both rolls in order to have them hot while the cloth is passing through; or in case it is desired that the fabric be cold rolled, the steam may be shut off and the fabric calendered without heat. In some cases where it is never desired to use the machine with hot rolls, smaller calender rolls are used without any arrangement for heating them.

**32.** At each side of the calender-rolling arrangement is a long rack, similar to  $k$ , Fig. 15, that rests on one of the journals of the wooden roll on which the cloth is wound. A gear  $p_2$  on a cross-shaft  $p$  extending across the calender-rolling arrangement engages with the rack  $k$ , a similar gear engaging with the rack on the opposite side, which is not shown in Fig. 15. Attached to this shaft is a friction pulley  $p_1$ , around which passes a friction strap  $p_3$  that is connected to a lever  $p_4$ . This lever is pivoted at  $p_5$  and so arranged that by raising it the friction can be immediately released, or by lowering it, as shown in Fig. 15, the friction can be applied to the friction pulley. When in the position shown, the lever  $p_4$  is held securely in place by means of a pin  $p_6$  that engages its hooked upper part. By means of this friction arrangement the racks place a considerable amount of pressure on the cloth as it is wound, so that a smooth, hard, and even roll of goods is produced. This pressure may be easily regulated by increasing or decreasing the amount of friction that the strap  $p_3$  places on the friction pulley  $p_1$ .

When a sufficient length of cloth has been wound around the cloth roll, it is removed by unhooking the latches  $m$  and swinging out the standards  $m_1$ , which are on each side of the calender-rolling head and pivoted on a pin at the lower part. These standards are lowered and the lever  $p_4$  raised, while by means of the hand wheel  $n$ , the racks are raised so as to relieve the pressure on the cloth roll, which is then removed from the machine and a new one inserted.

It is found, in practice, that by calendering the cloth in this way, especially in the case of hot calendering and where the upper roll is run faster than the lower one, there is a gain in length. This varies from  $1\frac{1}{2}$  to 5 per cent. and can be arranged to be still greater than this; but it is not desirable to stretch the goods too much, nor is there any ultimate advantage in doing so, since a certain length of the cloth has to be of a given weight, and the goods have to be made correspondingly heavier at the loom to offset the stretch.



**33.** After the roll of cloth has been formed and removed from the machine, it is customary to allow it to stand several hours or over night, after which the result of the steaming, calendering, and remaining under pressure for a considerable period is found to have imparted a very smooth appearance and feel to the fabric.

**34.** A cotton brushing machine with the attachments described occupies a floor space of about 10 feet by 7 feet and carries  $14'' \times 3\frac{1}{2}''$  tight and loose pulleys on a shaft revolving at a speed of about 400 revolutions per minute. Most of the belts connecting the various parts of the machine are 2 inches in width.