

# Carding Practices: Cotton and Synthetics

*By*

**JOHN K. STEARNS**

Director, School of Textiles  
International Correspondence Schools  
Member, American Association for Textile Technology

*In Collaboration With*

**JOHN CAUGHMAN, B.S. in T.M.**

Superintendent, Spartan Mills  
Past President, Southern Textile Association

Serial 6202

Copyright, 1955, by INTERNATIONAL TEXTBOOK COMPANY

Copyright in Great Britain. All rights reserved

Printed in U. S. A.



***International Correspondence Schools***

***Scranton, Pennsylvania***

***International Correspondence Schools Canadian, Ltd.***

***Montreal, Canada***

## *What This Text Covers . . .*

1. CARDS THAT ARE USED . . . . . Pages 1 to 5  
*The text begins with a brief review of prerequisite studies. Then follows a survey of the major makes of revolving-flat and roller-top cards used for carding cotton and synthetics.*
  
2. CARD CALCULATIONS . . . . . Pages 5 to 28  
*You'll begin here with the pulleys and belts, shafts and gears, that drive the various parts of the card. Then you'll find gearing diagrams for Saco-Lowell and Whitin cards. Next, you'll find rules and formulas for calculating the actual draft, the mechanical draft, the draft constant, and the draft gear for a card. Finally, you'll learn how to calculate the lickerin and doffer speeds, the production of the card, and the surface velocity of the various parts.*
  
3. SETTING THE CARD . . . . . Pages 28 to 51  
*This section starts you off with the right technique for setting a card. You'll study the gauges, and how to use them. Then, all the settings are discussed in the order in which they are usually made. Tables of the settings for revolving flat and roller-top cards are given for reference. Speed and production of the card in relation to setting are considered.*
  
4. STRIPPING AND MAINTENANCE . . . . . Pages 51 to 82  
*Here you'll first learn about the methods that can be used for stripping: the roll stripper, several types of vacuum strippers, and a central waste-collecting system. You'll see how stripping can be more or less eliminated. Next, you'll learn how to set up a card for grinding. Then you'll see how you can inspect a card and eliminate common troubles in carding.*
  
5. QUALITY CONTROL AND RESEARCH . . . . . Pages 82 to 112  
*Here you'll learn about scientific test methods. Waste and efficiency are the first problems considered. You'll learn also about methods to test the evenness of the sliver, and about nep counts. You'll take a look at what is being done by research, and see how it plays a part in improved carding methods.*

# Carding Practices: Cotton and Synthetics

## *Cards That Are Used*

### What You Need to Know

1. You wouldn't think of trying to study higher mathematics without a knowledge of simple arithmetic. Similarly, you can't get much out of studying carding practices unless you know the basic textile subjects. So, let's briefly review the prerequisites. If you remember them, that's all right. If you don't, review them before you go further.

By far the most common textile fiber is cotton. You should therefore have a fair knowledge of the cotton fiber. Even if you work with synthetic staple entirely, you should be familiar with cotton in a general way. The reason for this is simple: most cards were originally constructed for processing cotton. They have been modified, sometimes to a considerable extent, but basically they are still cotton cards. On the other hand, rayon and other synthetic staple are here to stay. So, even if you are presently working with cotton only, you should study man-made fibers as well.

If you know your fibers, you are ready to consider carding. We'll not go back to discuss *Carding Principles*, but will assume that you have studied these previously. The same is true of *Card Clothing*. Further, you'll find that you need *Mechanical Calculations*. Cards have belting, gearing, and some cam and lever action as well. You'll need to be familiar with the type of calculations used for such mechanisms.

**Why Study Carding Practices?**

2. If you work in a card room, and want to get ahead, you must study carding practices as a matter of course. It is not enough to learn just on the job, because then you would learn only one single type of card-room management. You should compare your practices with those of other mills, and learn the reasons behind these practices. This will lead to further improvements, as you experiment and see how many of those practices you can adapt to your own card room.

Many persons who are not carders should still have some idea of carding practices. The management trainee should know how every department in the mill operates. The methods engineer can't be very effective if he doesn't know the practices he is trying to improve. The spinner should know what the carder does, and what he can expect in the way of roving. The textile machine manufacturer must know the exact use that will be made of the machine he designs. In short, if you are interested in any way, directly or indirectly, in textile manufacturing, a knowledge of carding practices is indispensable.

To give you a further idea of the importance of carding, let's look at the equipment of a characteristic cotton spinning mill. The mill taken as an example has about 24,000 spindles and it is set up to produce 600 to 900 lb (pounds) of yarn per hour. Some of the yarn is combed, and some is carded. In such a mill you might find 140 cards, 12 combers, 10 drawing frames, 16 roving frames, and 80 spinning frames. The card room takes up about 40% of the floor space, the cards themselves about 20%. The exact numbers and percentages vary from one mill to the other, but in every case carding is a very important part of any spinning mill.

**Builders of Revolving-Flat Cards**

3. Since the beginning of the twentieth century, the revolving-flat card has been universally used for cotton. The same

card is used, with minor modifications, for the processing of fine, short-staple synthetics. Our study here will therefore be concerned mostly with revolving-flat cards. Most of these cards in the United States are built by two large companies: Whitin Machine Works and Saco-Lowell Shops. Both of these companies have built cards for well over a century. This fact, and the fact that they have survived when all other companies that built revolving-flat cards in the United States have not, would indicate that their cards are good and can be considered as the modern standard. All instructions given in this text, unless otherwise specified, will apply to both these cards.

There are no radical differences between the various modern revolving-flat cards. Of course, every machine company constantly works on improvements, and these improvements are widely publicized. However, the calculations and settings you will learn can usually be applied.

A few other names in cards may interest you, because they are found in some mills. In some old installations, you may find Pettee cards, built by a company that was merged with Saco-Lowell many years ago. In other mills you may find cards built by the H & B American Machine Company. This organization went out of the textile machine business in 1952, but spare parts for their machines are handled by Whitin.

Besides the American cards, you may find some cards that were imported from Europe. Most important of these are the cards by Platt Brothers, Oldham, England, imported into the United States by Atkinson, Haserick & Company. This covers the revolving-flat cards, with very few exceptions.

#### **Builders of Roller-Top Cards**

4. Although the revolving-flat card is fairly well standardized, the roller-top card is not. To understand the reason, let's look at the historical development of the two cards.

The revolving-flat card developed slowly, but without interruption, to its present state. The roller-top card, which had

#### 4      CARDING PRACTICES: COTTON AND SYNTHETICS

been used originally for long-staple cotton, disappeared from the cotton-carding picture by the beginning of the twentieth century. Roller-top cards, however, have always been used for woolen and worsted carding.

In the 1930's rayon staple came into the carding picture, to be followed later by acetate, then by nylon, and finally by the other synthetics. It was logical to assume that short synthetic staple could be processed on revolving-flat cards, and this turned out to be true. It was also logical that longer and coarser staple could be processed on worsted cards. However, at least in the United States, this did not happen for quite some time. Many progressive cotton mills immediately began to use synthetic staple, processing it on the available machinery. The woolen and worsted mills, however, repeated the mistake of the silk industry—with a few notable exceptions. They tried first to ignore, then to fight, the synthetics. Not until the 1950's did the majority of the woolen and worsted mills go seriously into synthetics and blends.

In the meantime the cotton mills had made good progress. Whiting, and also Saco-Lowell, built roller-top cards, on the same chassis as their revolving-flat cards. Building cards this way is advantageous. A mill can change from roller tops to revolving flats when fashion or economy indicate a change from cotton to synthetic staple, or vice versa.

There are other approaches to the carding of synthetic staple. Proctor & Schwartz for instance, built a card specifically designed for metallic wire card clothing. Also, as you'll remember, cylinders and doffers of all cards can be covered with metallic clothing. Platt builds a single-cylinder card for synthetics, similar to a single-cylinder worsted card. It will probably be many decades before the roller-top card for synthetic staple is anywhere near the standardization of the revolving-flat card. Under these conditions you cannot expect definite answers to all problems. You must, if you use roller-top cards, follow all developments closely, and keep experi-

menting until you arrive at a good solution for your particular problem. However, you'll always be able to use the basic calculations, suggested settings, and test procedures that you are about to study.

## *Card Calculations*

### **Card Gearing**

5. The ratio of speed, that is, the difference in surface speed between different parts of the card, is very important. In order to understand the various calculations, you must first have a clear picture of the card gearing. In Fig. 1 you'll see a simple sketch of the card as seen from one side. The other side is indicated in Fig. 2. The frame and all other distracting details have been left out so that you can clearly see the moving parts, the directions in which they move, and the belts, bands, shafts, and gears that connect the parts. We'll not repeat the purpose of the cards—if they are not familiar to you, review *Carding Principles*.

The main driving pulley of the card is shown in Fig. 1. The illustration shows this pulley driven by a belt from an overhead shaft. Some cards are driven instead by individual electric motors, either through belts or through silent chain drives. All you need to remember right now is that the drive is always on the cylinder shaft, and that all other parts are moved, directly or indirectly, from the cylinder shaft. On the other side of the cylinder shaft is a pulley with several flat and grooved faces, indicated in Fig. 2. The large flat face on this pulley carries a crossed belt that drives the lickerin.

Now go back to Fig. 1, and you'll find a pulley on the other side of the lickerin shaft. A long crossed belt from that pulley drives a pulley called the barrow pulley. Compounded with the barrow pulley is the barrow gear, which meshes with the doffer gear on the doffer shaft. This barrow gear is often

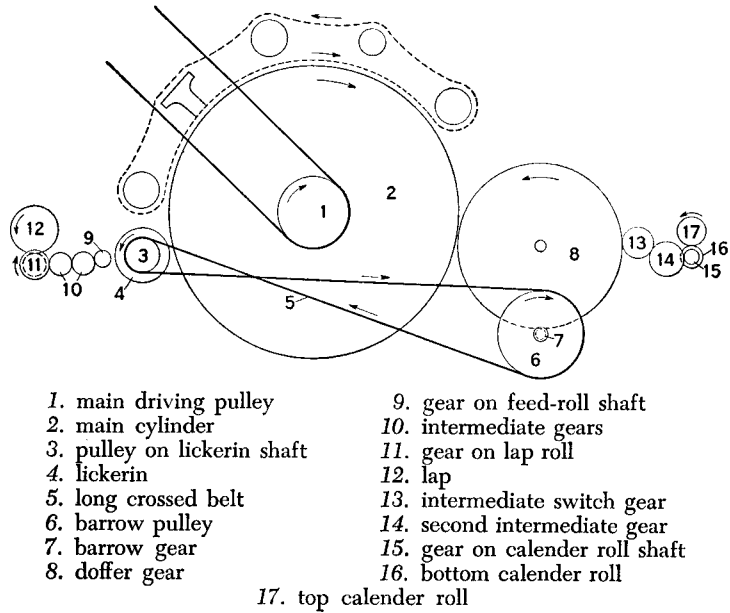

- 1. main driving pulley
- 2. main cylinder
- 3. pulley on lickerin shaft
- 4. lickerin
- 5. long crossed belt
- 6. barrow pulley
- 7. barrow gear
- 8. doffer gear
- 9. gear on feed-roll shaft
- 10. intermediate gears
- 11. gear on lap roll
- 12. lap
- 13. intermediate switch gear
- 14. second intermediate gear
- 15. gear on calender roll shaft
- 16. bottom calender roll
- 17. top calender roll

FIG. 1. CARD GEARING, RIGHT SIDE

called the production gear. It is the change gear that determines the amount of sliver delivered in a given time.

On the other side of the doffer, in Fig. 2, you'll see a bevel gear. This meshes with a bevel gear on the side shaft. The side shaft also carries a bevel gear on its other end, which meshes with a large bevel gear on the feed-roll shaft. On the other side of the feed roll, in Fig. 1, is a gear that drives the lap roll through two intermediate gears.

To summarize: the card feed is driven from the cylinder, through the lickerin and the doffer. You'll want to remember this, because it enters into the card calculations later.

6. Now let's look at some other connections which are important in driving the card, but which do not directly affect the draft and production of the card. The pulley on the cylinder shaft, Fig. 2, has a grooved surface. A band over this grooved surface connects the pulley on the cylinder shaft



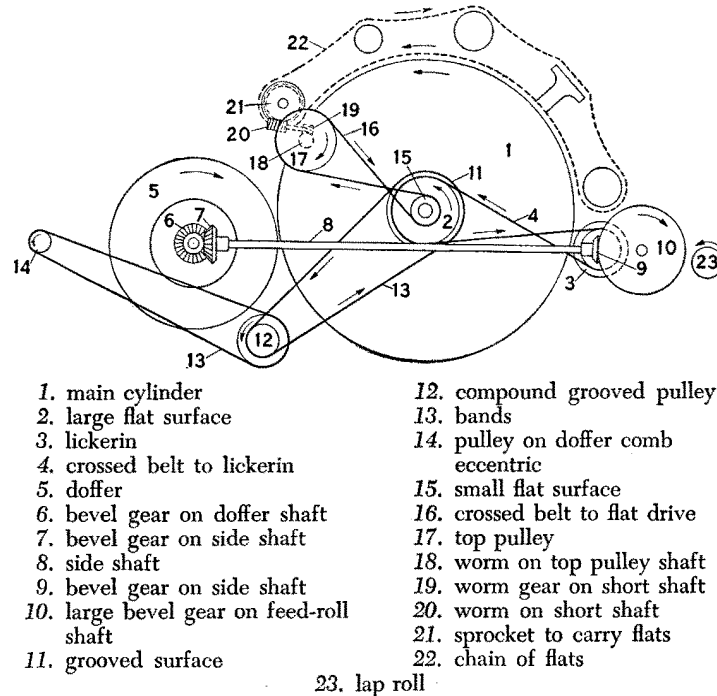
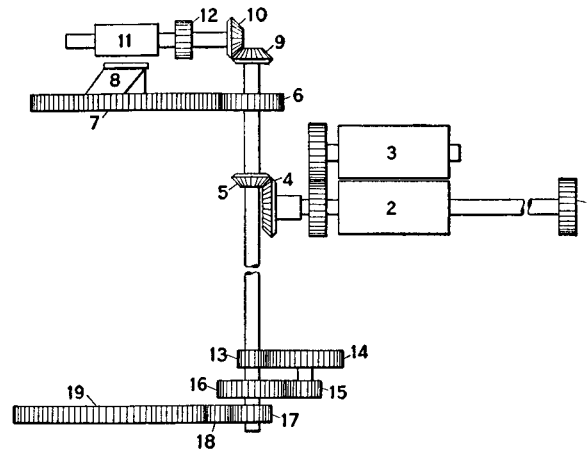

FIG. 2. CARD GEARING, LEFT SIDE

to a compound grooved pulley below and to the left of the main cylinder on the card. By means of this band, the pulley on the cylinder shaft drives the compound pulley. Another band leads from the compound pulley to the pulley on a short shaft which carries the eccentric for the doffer comb motion.

A smaller flat surface on the cylinder pulley is connected by means of a crossed belt to the pulley on top of the card. This pulley is on a short shaft, with a worm on the other side of this shaft. A short connecting shaft, with a worm gear on one side and a second worm on the other, connects the short pulley shaft with the sprockets that carry the flats on them.

This completes the main driving features except for the coiler and the parts connected to it. The drive for all these parts comes from a large gear on the end of the doffer, shown in



- |   |  |
|---|--|
| 1. gear on calender roll shaft (15 in Fig. 1) | 10. bevel gear on coiler calender-roll shaft |
| 2. bottom calender roll                       | 11. first coiler calender roll               |
| 3. top calender roll                          | 12. gear to second coiler calender roll      |
| 4. bevel gear on end of calender roll shaft   | 13. drive gear on upright shaft              |
| 5. bevel gear on upright shaft                | 14. driven gear on stud                      |
| 6. drive gear for tube gear                   | 15. drive gear on stud                       |
| 7. tube gear                                  | 16. driven gear on sleeve                    |
| 8. coiler gear                                | 17. drive gear on sleeve                     |
| 9. bevel gear on top of upright shaft         | 18. carrier gear                             |
|   | 19. can-table gear                           |

FIG. 3. COILER AND CAN GEARING

Fig. 1. This doffer gear drives the gear on the calender roll shaft through two intermediate gears. The first one of these gears is mounted on a switch cam, and fitted with a handle. By moving the handle, the gears can be disengaged to stop the whole calender assembly, including the drive for the coiler. On the end of the calender roll shaft is a bevel gear which meshes with a bevel gear on the upright shaft from which the whole coiler assembly is driven. We'll consider these in more detail later.

#### Coiler Assembly Drive

7. To understand the driving of the coiler assembly, look at Fig. 3. You'll note the calender rolls, and the bevel gears

connecting the assembly to the upright shaft. Near the top of the upright shaft is a gear that drives the large tube gear on the coiler plate. On the top of the upright shaft is a bevel gear, which meshes with another bevel gear on the coiler calender-roll shaft. The second coiler calender roll is connected with the first by two gears of equal size. These are not shown in the illustrations, since they don't affect any speed ratio, and they would be hard to show because the second roll is directly behind the first.

At the bottom of the upright shaft is a train of gears that drives the can table. This train seems to be somewhat round-about. The reason is that the can table must move very slowly; you'll find a small gear meshing with a large one until the speed has been reduced. The small drive gear on the upright shaft meshes with a large driven gear, that is, compounded with a small drive gear on an upright stud. This drive gear meshes with a similar pair that is compounded on a sleeve on the upright shaft. Since these gears are on a sleeve, they are held by, but don't receive the motion of, the upright shaft. The small gear on the sleeve drives the gear on the can table through a carrier gear.

This finishes the discussion of the drive, but keep the figures before you, so that you can compare them with the gearing diagrams.

#### Gearing Diagrams

8. You'll find a gearing diagram for a Saco-Lowell card in Fig. 4, while a similar diagram for a Whitin card is shown in Fig. 5. These diagrams, which you will want to consult as you study calculations and formulas, have been printed on separate insert. Remove them from the text so that you can keep them handy. Put them back when you get through with them so they don't get lost.

Cards are described as right-hand or left-hand. Saco-Lowell and Whitin call a card right-hand if the drive pulley is

at your right when you face the delivery end. By that definition, the card shown in Fig. 4 is a left-hand card. The card shown in Fig. 5 is a right-hand card. Of course, both machine builders build cards either way, to fit the needs of their customers. The cards were selected this way simply to show you that the gearing is quite similar, though located on opposite sides.

Here is a point you must remember if you work with English cards, or with cards built by the H & B American Machine Company. These cards are called right-hand if the drive is on the right when you face the feed end; that is, just the opposite of most American cards. You have to keep this in mind when you order spare parts, or set up the layout for a card room.

The major parts, such as cylinder, lickerin, and doffer, have been labeled in Figs. 4 and 5 to help you find your way through the diagram. The numbers in inches, given for rolls and pulleys, refer to the diameter of the part. The numbers on the gears refer to the number of teeth. The letters in parentheses, (*D*) for draft change gear and (*P*) for production change gear, will match the letters used in the formulas. Now review the articles on card gearing, and locate all parts as far as you can on the gearing diagrams. The band drive to the doffer comb, the drive for the flats, and some of the gearing on the upright coiler shaft have been left out of the diagrams, in order to simplify them as much as possible.

### **Draft in Carding**

9. Throughout the processing of fibers into yarn, you'll find the problem of draft, also called drawing or attenuation. The word attenuate means "to make thin, or slender." If you want to study what happens in carding to convert the thick picker lap into a slender card sliver, give a stick of chewing gum to your kid sister or your little daughter, or to any child you have handy. She will first pop the wad of gum in her mouth and

soften it by chewing around on it. Next, she will hold one end of the gum with her teeth, grab the other end with her fingers, and pull the gum into a long string. Practically the same thing happens in carding.

The cotton fibers in the picker lap tend to stick together. In the process of carding, the fibers are pulled apart, without losing contact with each other. Take, for example, a 14-oz (ounce) picker lap. One yard of this lap weighs 14 oz = 6,125 grains. Let's say the card produces 60-grain sliver, that is, 1 yd (yard) of the sliver weighs 60 grains. It then follows that 1 yd of picker lap has been drafted into  $6,125 \div 60 = 102$  yd of sliver. This would be called a draft of 102, or 102 draft. Although the draft in carding changes, it is normally between 80 and 120, and a draft of 100 is about average.

#### The Actual Draft

**10.** When you compare the picker lap with the sliver, as we have just done, you get the draft. This draft is called the *actual* draft and is not to be confused with the *mechanical* draft, which we'll consider later. Now let's look at a few problems in connection with the actual draft of a card.

To find the actual draft of a card, you must know 1) that there are 437.5 grains in 1 oz, 2) the weight of the picker lap to be carded, and 3) the weight of the sliver the card produces. Then:

**Rule:** To find the actual draft of a card, multiply the weight of the lap by 437.5, and divide the result by the weight of the sliver.

$$\text{FORMULA: } A = \frac{W_L \times 437.5}{W_s}$$

in which  $A$  = actual draft of the card;

$W_L$  = weight of lap, in ounces per yard;

$W_s$  = weight of sliver, in grains per yard.

12      CARDING PRACTICES: COTTON AND SYNTHETICS

EXAMPLE. You have 14-oz lap and want 60-grain sliver. What card draft do you need?

SOLUTION.  $A = \frac{14 \times 437.5}{60} = 102.1$ , or approximately 100 actual draft.    Ans.

11. It may happen that you have a card set up, and you have determined the actual draft. Now you want to feed a different weight of lap, and want to calculate the weight of the sliver. The necessary calculation can be based on the rule and the formula in Art. 10, by simply moving the letters around:

FORMULA 1:       $W_s = \frac{W_L \times 437.5}{A}$

EXAMPLE 1. You have a card set up for an actual draft of 100 and intend to feed 14-oz lap. What weight of sliver will the card deliver?

SOLUTION.  $W_s = \frac{14 \times 437.5}{100} = 61.3$ , or approximately 60-grain sliver.    Ans.

There is still another possibility. Suppose that you know the draft and the sliver, but you want to find the lap needed. You'll have to juggle your formula once more:

FORMULA 2:       $W_L = \frac{W_s \times A}{437.5}$

EXAMPLE 2. You need 60-grain sliver. The card is set up for a draft of 100. What weight of picker lap do you need?

SOLUTION.  $W_L = \frac{60 \times 100}{437.5} = 13.71$ , or approximately 14-oz lap.    Ans.

These calculations are fine if you keep accurate records of your actual draft, if you can count on very even picker laps, and if you don't want to experiment with your card setup. But when you change anything, you'll have to go into further calculations.

**The Mechanical Draft**

12. Suppose you put a little speed counter on the surface of the feed roll in a card, and find that this surface moves 2.5 in. per minute. Then you perform the same experiment on the doffer, and you find that the surface of the doffer moves at the rate of 250 in. per minute. You will have a draft of  $250 \div 2.5 = 100$  between the feed roll and the doffer. Of course this is the mechanical draft, and it differs from the actual draft in that no waste is considered. We'll study the mechanical draft before we worry about the waste.

When you studied mechanical calculations, you learned that you can compare the diameters of pulleys instead of their circumferences. The same is true of the draft. You can simply compare the diameters of two rolls, consider the gearing between them, and thereby determine the draft. In setting up a draft formula, you start with the number of teeth on the gear on the first roll that moves the fibers. Divide the number of teeth on this gear by the number of teeth on the next gear in the train, omitting the teeth on the intermediate gears, which act as both drivers and followers. Now you multiply by the number of teeth on the next gear, divide by the number of teeth on the next gear, and so on until you come to the last roll that moves the fibers. Multiply by the diameter in inches of this roll, and finally divide by the diameter in inches of the first roll. This sounds more complicated than it is, so we'll use some practical examples and see how it works.

13. Let's start out by finding the draft between the lap roll and the feed roll in the Saco-Lowell card shown in Fig. 4. We'll set up the formula as described in the preceding article:

$$\text{FORMULA:} \quad M_1 = \frac{47 \times F}{17 \times L}$$

in which  $M_1$  = mechanical draft between lap roll and feed roll;  
 $F$  = diameter of feed roll;  
 $L$  = diameter of lap roll.

14      CARDING PRACTICES: COTTON AND SYNTHETICS

EXAMPLE. Find the mechanical draft between lap roll and feed roll in a card geared as shown in Fig. 4.

SOLUTION.  $M_1 = \frac{47 \times 2.25}{17 \times 6} = 1.037$  draft. Ans.

You'll remember from your study of *Mechanical Calculations* that idlers and intermediate gears don't change the speed ratio; hence the two 31-tooth gears are disregarded. Note that the draft of 1.037 is negligible. It does not actually draft the lap at all; it merely keeps the lap stretched out while it is moving. Such a draft is called a tension draft. You'll find tension draft between rolls that merely transport the fibers, without changing the formation of the stock.

14. Looking at the diagram, Fig. 4, you'll notice that the feed roll is connected, through the horizontal shaft, to the doffer. Later we'll explain the intermediate drafts between feed roll, lickering, cylinder, and doffer. Right now we can disregard them, since they don't affect the total mechanical draft of the card.

FORMULA:  $M_2 = \frac{120 \times 40 \times R}{D \times 45 \times F}$

in which  $M_2$  = mechanical draft between feed roll and doffer;  
 $R$  = diameter of doffer;  
 $D$  = number of teeth on draft change gear;  
 $F$  = diameter of feed roll.

EXAMPLE. Find the mechanical draft between the feed roll and the doffer in a card geared like Fig. 4. Use a 15-tooth gear as draft change gear.

SOLUTION.  $M_2 = \frac{120 \times 40 \times 27}{15 \times 45 \times 2.25} = 85.3$  draft. Ans.

Here, then, is the main draft of the card. While the other gears that affect the draft are rarely changed, the draft gear  $D$  is one of the two important change gears on the card.



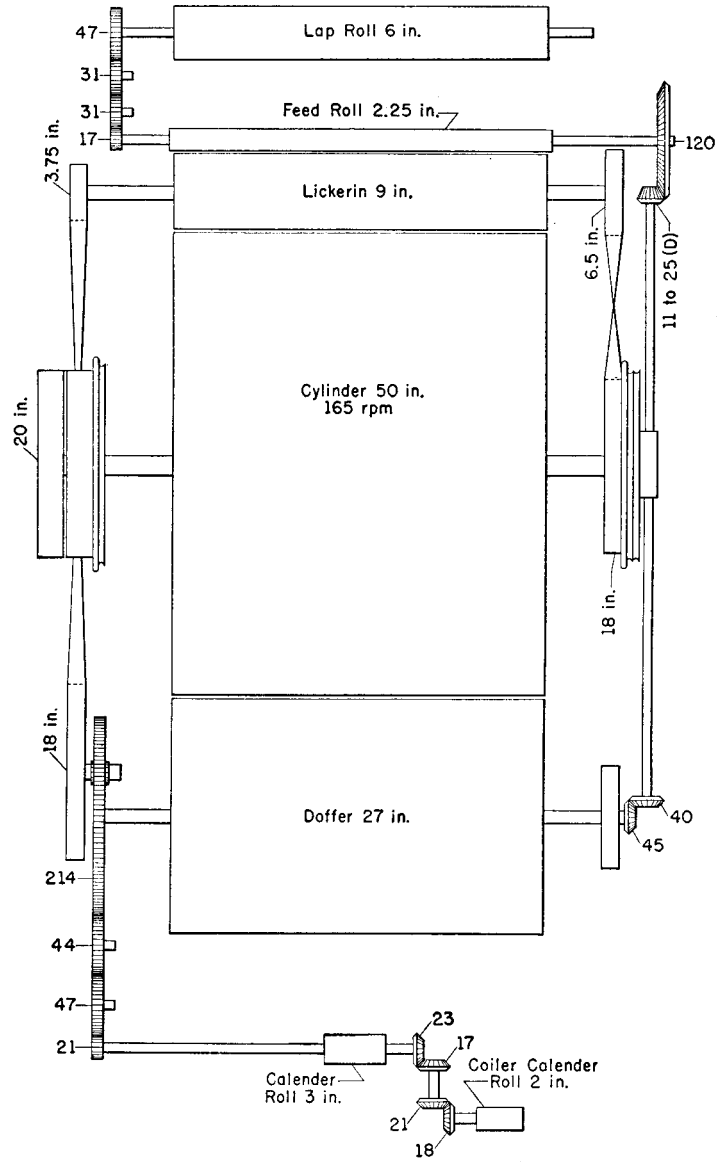

6202-73932

FIG. 4. GEARING DIAGRAM (SACO-LOWELL)

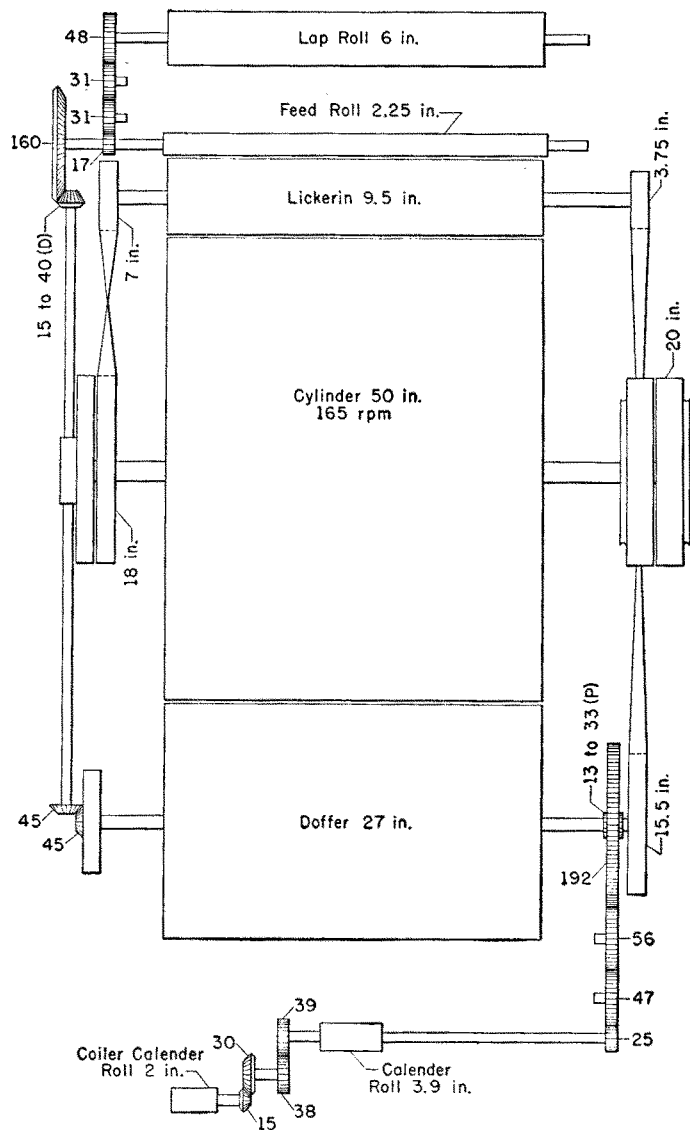

6202-73932

FIG. 5. GEARING DIAGRAM (WHITIN)

15. You'll need the draft between the doffer and the calender roll, which we'll call  $M_3$ . Finally, you'll need the draft between the calender roll and the coiler calender roll, which we'll call  $M_4$ . You have learned how to set up these formulas, so we'll not bother to go through the process again.

EXAMPLE. Find the mechanical drafts between the doffer and the calender roll, and between the calender roll and the coiler calender roll, in a card geared like Fig. 4.

$$\text{SOLUTION. } M_3 = \frac{214 \times 3}{21 \times 7} = 1.132 \text{ draft between doffer and calender roll. Ans.}$$

$$M_4 = \frac{23 \times 21 \times 2}{17 \times 18 \times 3} = 1.052 \text{ draft between calender roll and coiler calender roll. Ans.}$$

If you have trouble in following the gearing to the coiler calender roll on the diagram, look at Fig. 3. Note that there are only the two pairs of bevel gears to be considered.

16. Having determined the intermediate drafts, we can now find the total mechanical draft of the card. This can be done by multiplying all of the intermediate drafts.

$$\text{FORMULA 1: } M = M_1 \times M_2 \times M_3 \times M_4$$

in which  $M$  = mechanical draft of the card;

$M_1$  = draft between lap roll and feed roll;

$M_2$  = draft between feed roll and doffer;

$M_3$  = draft between doffer and calender roll;

$M_4$  = draft between calender roll and coiler calender roll.

EXAMPLE 1. Find the draft  $M$  of a card where  $M_1 = 1.037$ ;  $M_2 = 85.3$ ;  $M_3 = 1.132$ ; and  $M_4 = 1.052$ .

$$\text{SOLUTION. } M = 1.037 \times 85.3 \times 1.132 \times 1.052 = 105.3 \text{ draft. Ans.}$$

You can also calculate through the whole card in one operation. Simply follow the gearing between lap roll and coiler calender roll. Disregard all the intermediate rolls.

FORMULA 2:

$$M = \frac{47 \times 120 \times 40 \times 214 \times 23 \times 21 \times D_R}{17 \times D \times 45 \times 21 \times 17 \times 18 \times L}$$

in which  $M$  = mechanical draft; $D_R$  = diameter of coiler calender roll; $D$  = number of teeth on draft change gear; $L$  = diameter of lap roll.

EXAMPLE 2. Find the mechanical draft for a card geared like Fig. 4, if the draft change gear has 15 teeth.

SOLUTION. 
$$M = \frac{47 \times 120 \times 40 \times 214 \times 23 \times 21 \times 2}{71 \times 15 \times 45 \times 21 \times 17 \times 18 \times 6} =$$
  
105.4 mechanical draft.    Ans.

Note that, by using the two methods of calculating the draft, you have a suitable means of checking your results. The small and insignificant difference between 105.3 and 105.4 is due to rounding off the numbers for easier calculation.

#### Draft Constant

17. You don't want to calculate through the whole train of gears every time you change drafts. After all, normally you'll change only the draft change gear. It therefore saves a lot of time if you determine the draft constant. For this purpose you use a formula similar to that used for finding the draft, but without the draft gear  $D$ .

EXAMPLE. Find the draft constant  $C$  for the card shown in Fig. 4.

SOLUTION. 
$$C = \frac{47 \times 120 \times 40 \times 214 \times 23 \times 21 \times 2}{17 \times 45 \times 21 \times 17 \times 18 \times 6} =$$
  
1,581 draft constant.    Ans.

As you can guess from the size of the constant, it is technically a constant dividend. That is, you divide the constant by the draft to find the number of teeth on the change gear.

Or, you divide the constant by the number of teeth on the change gear to find the draft.

18. To make working with the draft constant quite clear, we'll set up three formulas that are easy to remember.

$$\text{FORMULA 1:} \quad D = \frac{C}{M}$$

$$\text{FORMULA 2:} \quad M = \frac{C}{D}$$

$$\text{FORMULA 3:} \quad C = M \times D$$

in which  $D$  = number of teeth on the draft gear;

$C$  = draft constant;

$M$  = mechanical draft.

EXAMPLE 1. You have a card with a draft constant of 1,581. What draft gear will you use to get a mechanical draft of approximately 105?

$$\text{SOLUTION.} \quad D = \frac{1,581}{105} = 15\text{-tooth draft gear. Ans.}$$

EXAMPLE 2. You have a card with a draft constant of 1,581 and a 15-tooth change gear. What will the mechanical draft of the card be?

$$\text{SOLUTION.} \quad M = \frac{1,581}{15} = 105.4 \text{ mechanical draft. Ans.}$$

EXAMPLE 3. You know that the mechanical draft of a card is 105.4, and that the card has a 15-tooth draft gear. What is the draft constant of the card?

$$\text{SOLUTION.} \quad C = 105.4 \times 15 = 1,581 \text{ draft constant. Ans.}$$

You have now learned how to determine the draft constant for any given card and how to use it. However, for most purposes you will need the actual draft, rather than the mechanical draft. So, let's see how these drafts can be compared with each other.

**Drafts and Waste**

19. The mechanical draft, or machine draft as it is sometimes called, is based on only the surface velocity of the rolls or cylinders that move the stock. If no waste were removed, the mechanical draft would equal the actual draft. The waste ranges from about 5% in normal cotton carding to considerably less in carding synthetics. We'll see later how accurate waste tests are made. For the time being, it is enough to remember that the waste percentage must be accurately determined, otherwise your calculations cannot be accurate either.

Now let's see how the mechanical draft compares to the actual draft. You can use the following formulas to compare the two drafts.

$$\text{FORMULA 1: } M = \frac{A \times (100 - W)}{100}$$

$$\text{FORMULA 2: } A = \frac{M \times 100}{100 - W}$$

in which  $M$  = mechanical draft;  
 $A$  = actual draft;  
 $W$  = waste percentage.

EXAMPLE 1. You have determined by tests that the actual draft of a card is 106.7, and that the card makes 5% waste. What is the mechanical draft of this card?

$$\text{SOLUTION. } M = \frac{106.7 \times (100 - 5)}{100} = 101.4 \text{ mechanical draft. Ans.}$$

EXAMPLE 2. You have calculated the mechanical draft of a card to be 101.5, and determined that the card makes 5% waste. What is the actual draft of the card?

$$\text{SOLUTION. } A = \frac{101.4 \times 100}{100 - 5} = 106.7 \text{ actual draft. Ans.}$$

In practice the actual draft is often determined as a result of a calculation. You may therefore hear this draft called

resultant draft. Remember that resultant draft and actual draft are the same.

#### Determination of Draft Gear

20. It often happens that you want to change the draft of a card in order to change the weight of the sliver. When you studied the draft constant, you found that the draft multiplied by the draft gear gives the constant. You can deduce then that:

$$\text{FORMULA 1: } D_1 \times M_1 = D_2 \times M_2$$

in which  $D_1$  = number of teeth on the present draft gear;  
 $M_1$  = present mechanical draft;  
 $D_2$  = number of teeth on the changed draft gear;  
 $M_2$  = changed mechanical draft.

You can further deduce that, if the waste percentage remains unchanged, the actual drafts will be in the same proportion to the numbers of teeth on the change gears as the mechanical drafts. Consequently, when you want to change the draft, and when there is no change in waste percentage, you can find very simply the draft gear to use.

$$\text{FORMULA 2: } D_2 = \frac{D_1 \times A_1}{A_2}$$

in which  $D_2$  = number of teeth on the required draft gear;  
 $D_1$  = number of teeth on the present draft gear;  
 $A_1$  = present actual draft;  
 $A_2$  = desired actual draft.

**EXAMPLE.** You have a card set up to make 60-grain sliver from 14-oz lap. You want to change to 55-grain sliver from the same lap. You are now using a 15-tooth change gear. The waste percentage is to remain unchanged. Consequently, you can use the formula you studied in Art. 10 to find the present and desired actual draft. What change gear will you need?

$$\text{SOLUTION. } A_1 = \frac{14 \times 437.5}{60} = 102.1 \text{ present actual draft}$$

$$A_2 = \frac{14 \times 437.5}{55} = 111.4 \text{ desired actual draft}$$

$$D_2 = \frac{15 \times 102.1}{111.4} = 13.7, \text{ or } 14\text{-tooth draft gear. Ans.}$$

Remember, you can use this formula only when the waste percentage remains unchanged. It does not apply if you take more or less waste out than before the change.

In the preceding calculation you noticed that a 15-tooth change gear resulted in 60-grain sliver, but a 14-tooth change gear was needed to produce 55-grain sliver. Since a smaller change gear gives lighter sliver, the gear and the sliver weight are in direct proportion. Remember that, if the sliver is too heavy, you must use a smaller change gear.

#### Lickerin and Doffer Speed

21. While you studied the draft, you jumped directly from the feed roll to the doffer, and from there to the calender roll. Since both are connected with gearing to the doffer, this procedure was justified: any change in doffer speed will be equally transmitted to the two rolls. Consequently, changes in doffer speed do not affect the draft in any way.

Now let's look at it another way. The speed of the doffer determines the speed of the intake, as well as the speed of the delivery. Consequently, there is a direct relation between the speed of the doffer and the production of the card. Speed up the doffer by putting on a larger barrow gear, and you will increase the number of pounds of sliver delivered per hour. Slow down the doffer by putting on a smaller barrow gear, and the card will deliver fewer pounds of sliver per hour.

Going back to the gearing diagram, Fig. 4, you'll note that the cylinder shaft carries a pulley with an 18-in. (inch) flat face, connected by a crossed belt to a 6.5 in. pulley on the lickerin shaft. Most revolving-flat cards are run with a main cylinder speed of 165 rpm (revolutions per minute). If you work in a mill where the main cylinder speed differs from the



standard 165 rpm, you can easily substitute this figure in the following calculations.

$$\text{FORMULA: } R_L = \frac{R_C \times C_P}{L_P}$$

in which  $R_L$ =revolutions per minute of lickerin;  
 $R_C$ =revolutions per minute of cylinder;  
 $C_P$ =diameter in inches of flat surface on cylinder pulley;  
 $L_P$ =diameter in inches of driven pulley on lickerin.

**EXAMPLE.** If a card is geared as shown in Fig. 4, and the cylinder makes 165 rpm, what will be the speed of the lickerin?

$$\text{SOLUTION. } R_L = \frac{165 \times 18}{6.5} = 457 \text{ rpm of lickerin. Ans.}$$

Having determined the speed of the lickerin, we can proceed to the doffer.

**22.** You'll see in the gearing diagram, Fig. 4, that a 3.75-in. pulley on the lickerin shaft drives the 18-in. barrow pulley. This pulley is compounded with the barrow gear, or doffer change gear, often called the production change gear. The change gear meshes with the 214-tooth gear on the doffer shaft. Adding these gears to the formula in the preceding article, we get:

$$\text{FORMULA: } R_D = \frac{R_C \times C_P \times L_D \times P}{L_P \times B \times G}$$

in which  $R_D$ =revolutions per minute of doffer;  
 $R_C$ =revolutions per minute of cylinder;  
 $C_P$ =diameter in inches of flat surface on cylinder pulley;  
 $L_D$ =diameter in inches of drive pulley on lickerin;  
 $P$ =number of teeth on production gear;  
 $L_P$ =diameter in inches of driven pulley on lickerin;  
 $B$ =diameter in inches of barrow pulley;  
 $G$ =number of teeth on large driven gear on doffer shaft.

EXAMPLE. A card is geared as shown in Fig. 4. The cylinder makes 165 rpm. A 25-tooth production change gear is used. What is the speed of the doffer?

$$\text{SOLUTION. } R_D = \frac{165 \times 18 \times 3.75 \times 25}{6.5 \times 18 \times 214} = 11.12 \text{ rpm of doffer. Ans.}$$

Although other gears and pulleys on the card are seldom changed, the draft change gear and the production change gear must often be calculated. As you have seen, a draft constant greatly simplifies the draft calculations. Similarly, a doffer constant can simplify the doffer calculations.

#### Doffer Constant

23. The doffer constant can be determined by the same formula that has been used in the preceding article to find the doffer speed. All we have to do is to use the same formula, but omit the change gear.

$$\text{FORMULA: } H = \frac{R_C \times C_P \times L_D}{L_P \times B \times G}$$

in which  $H$  = doffer constant;

$R_C$  = revolutions per minute of cylinder;

$C_P$  = diameter in inches of flat surface on cylinder pulley;

$L_D$  = diameter in inches of drive pulley on lickerin;

$L_P$  = diameter in inches of driven pulley on lickerin;

$B$  = diameter in inches of barrow pulley;

$G$  = number of teeth on large driven gear on doffer shaft.

EXAMPLE Calculate the doffer constant for a card geared as shown in Fig. 4.

$$\text{SOLUTION. } H = \frac{165 \times 18 \times 3.75}{6.5 \times 18 \times 214} = 0.445 \text{ doffer constant. Ans.}$$

You'll notice that the doffer constant is quite small. Contrary to the draft constant, which is a constant dividend, the doffer constant is technically a constant factor.

24. The doffer constant when multiplied by the number of teeth of the production gear will give the doffer speed. On the other hand, the revolutions per minute of the doffer, multiplied by the constant, will give the number of teeth on the production gear.

$$\text{FORMULA 1: } R_D = H \times P$$

$$\text{FORMULA 2: } P = \frac{R_D}{H}$$

in which  $R_D$  = revolutions per minute of doffer;

$H$  = doffer constant;

$P$  = number of teeth on production gear.

EXAMPLE 1. A 25-tooth production gear has been put on a card with a doffer constant of 0.445. What is the speed of the doffer?

SOLUTION.  $R_D = 0.445 \times 25 = 11.13$  rpm of doffer. Ans.

EXAMPLE 2. A card has a doffer constant of 0.445. What production gear will you use to get a doffer speed of approximately 11 rpm?

SOLUTION.  $P = \frac{11}{0.445} = 24.7$ , or 25-tooth production gear. Ans.

Now that you know how to calculate the doffer speed, you are ready to calculate the production of the card.

### Production Calculations

25. As you know, the sliver produced by the card is delivered into the sliver can by the coiler calender rolls. You must therefore multiply the revolutions per minute of the doffer by the number of teeth on each driving gear between the doffer and the coiler calender roll; and divide by the number of teeth on each driven gear in that train. Then you multiply by the diameter of the coiler calender roll and by 3.14, to get the production in inches per minute. However, you want the production in pounds per hour. So you multiply by 60 (minutes per hour) and divide by 36 (inches per yard).

Then you multiply by the weight of the sliver in pounds, divided by 7,000 (grains per pound). Finally, you must allow for stoppages due to stripping and repairs. So multiply by the efficiency percentage and divide by 100. Now look at Fig. 4 again, and see how the following formula was set up.

FORMULA:

$$P_A = \frac{R_D \times 214 \times 23 \times 21 \times 2 \times 3.14 \times 60 \times W_s \times E}{21 \times 17 \times 18 \times 36 \times 7,000 \times 100}$$

in which  $P_A$  = average production of card per hour;

$R_D$  = revolutions per minute of doffer;

$W_s$  = weight of sliver, in pounds;

$E$  = efficiency percentage.

Note that the 44-tooth and the 47-tooth gear between doffer and calender roll are intermediate gears. They do not influence the speed ratio.

EXAMPLE. You have a card geared as shown in Fig. 4. The doffer makes 11.12 rpm. You are producing 54-grain sliver at 90% efficiency. What will be the average card production per hour?

SOLUTION. 
$$P_A = \frac{11.12 \times 214 \times 23 \times 21 \times 2 \times 3.14 \times 60 \times 54 \times 90}{21 \times 17 \times 18 \times 36 \times 7,000 \times 100} =$$

12.97, or 13 lb per hr (hour) average production.    Ans.

When you want the production of a whole card room by the week, you simply multiply the average production of the card by the number of cards in the room and by the number of hours the mill works per week. Years ago the working day was 10 hr. You'll therefore find the production of cards is sometimes calculated per 10 hr, rather than per 1 hr. Of course, it is simply a matter of moving the decimal point to convert one to the other.

#### Short Production Formula

26. Of all the factors in the production formula, only two are likely to change often: the speed of the doffer and the weight of the sliver to be produced. You can therefore reduce the production formula given in the preceding article.

FORMULA:  $P_A = R_D \times W_S \times 0.0216$

in which  $P_A$  = average production of card per hour;

$R_D$  = revolutions per minute of doffer;

$W_S$  = weight of sliver.

EXAMPLE. You have determined the short production formula for a card with a constant of 0.0216. What is the production of the card if the doffer makes 11.12 rpm and the card produces 54-grain sliver?

SOLUTION.  $P_A = 11.12 \times 54 \times 0.0216 = 12.97$ , or 13 lb per hr average production. Ans.

The result obtained by using this formula is close enough for practical work. However, you must remember that, after this short formula has been determined, you can only use it when you change nothing except the doffer speed and the sliver weight.

#### Calculations for Surface Velocity

27. The calculations you have studied up to this point are used in regular card-room practice. However, at times, further calculations may interest you. In many mills, experiments are carried out. Sometimes there are new fibers to deal with. Perhaps you have read about experiments in other mills, and want to try them. In any case, you should be able to calculate beforehand what effect certain changes will have, instead of going ahead blindly.

One factor that is most important is the speed at which the surface of a roll or cylinder moves, technically called the surface velocity. Fortunately, this is not difficult to determine.

FORMULA: 
$$V = \frac{R_C \times D_C \times \pi}{F}$$

in which  $V$  = surface velocity, in feet per minute;

$R_C$  = speed, in revolutions per minute;

$D_C$  = diameter of roll or cylinder, in inches;

$\pi = 3.14$ , to change diameter to circumference;

$F$  = number of inches in 1 foot,

26 CARDING PRACTICES: COTTON AND SYNTHETICS

**EXAMPLE.** The main cylinder of a card has a diameter of 50 in., or 50.75 in. to be exact, since you must allow for  $\frac{3}{4}$  in. of card clothing. The cylinder makes 165 rpm. What is the surface velocity of the cylinder?

**SOLUTION.** 
$$V = \frac{165 \times 50.75 \times 3.14}{12} = 2,190 \text{ ft (feet) per min (minute). Ans.}$$

**28.** In the draft calculations you found that the main draft was between the feed roll and the doffer. Now let's compare the surface velocities of the feed roll, the lickerin, the cylinder, and the doffer, to see what actually happens to the stock on the card. As an example we'll use a card geared as shown in Fig. 4, with a 25-tooth production change gear, and a 15-tooth draft change gear. If you understand mechanical calculations you should be able to follow the calculations without lengthy explanations. Just look at the diagram and compare the diameters and gears.

The speed  $R_L$  of the lickerin is:

$$R_L = \frac{165 \times 18}{6.5} = 457 \text{ rpm}$$

The surface velocity  $V_L$  of the lickerin, the metallic clothing of which hardly protrudes and can be disregarded, is:

$$V_L = \frac{457 \times 9 \times 3.14}{12} = 1,076 \text{ ft per min}$$

The speed  $R_D$  of the doffer is:

$$R_D = \frac{457 \times 3.75 \times 25}{18 \times 214} = 11.12 \text{ rpm}$$

The surface velocity  $V_D$  of the doffer, allowing for  $\frac{3}{4}$ -in. clothing, is:

$$V_D = \frac{11.12 \times 27.75 \times 3.14}{12} = 80.7 \text{ ft per min}$$

The speed  $R_F$  of the feed roll is:

$$R_F = \frac{11.12 \times 45 \times 15}{40 \times 120} = 1.564 \text{ rpm}$$

The surface velocity  $V_F$  of the feed roll is:

$$V_F = \frac{1.564 \times 2.25 \times 3.14}{12} = 0.921 \text{ ft per min}$$

29. Now let's see what these surface velocities tell. The feed roll feeds only a few inches of lap per minute. The draft between feed roll and lickerin is tremendous:  $1,076 \div 0.921 = 1,168$  draft. Then, between lickerin and cylinder, there is another draft:  $2,190 \div 1,076 = 2.04$  draft. These drafts, of course, tend to separate the fibers from each other, and much of the carding action is due to this separation.

What happens between the cylinder and the doffer? You get a "draft" figure of  $80.7 \div 2,190 = 0.0368$ , which is less than 1. A draft of 1 would be no draft at all, so a "draft" of 0.0368 is less than no draft; it is the exact opposite, namely, a condensing action. The web from the cylinder is loaded on the doffer, and you can readily see how the doffer would become loaded if it were not stripped by the doffer comb.

The interplay of drafts and condensing action is, of course, changed somewhat when you change draft or production gears or both. Even greater changes can occur when you change pulleys or other gears. It is always wise to determine the resulting surface velocities before you make such changes. You can then visualize what will happen to the drafts between the card surfaces.

After this brief excursion into the field of carding theory we'll return to practical card operation. But first, let's practice draft and production calculations.

30. You should practice the use of the calculations you have studied, so that you can perform them when necessary. For practice, we have selected practical situations that you may

run into when changing from cotton to rayon. Try the problems given here. Then check at the end of the text to see if you have the right answers.

### *Practice Problems*

1. Rayon staple is run on a revolving-flat card. The  $12\frac{1}{2}$ -oz picker laps are to be converted into 50-grain sliver. What is the actual draft needed?
2. *a)* When carding rayon staple, it is customary to run the doffer at lower speeds than when carding cotton. In order to get a lower doffer speed, a smaller pulley on the lickerin may be used to drive the barrow pulley. Suppose you have a card geared as shown in Fig. 4, with a cylinder speed of 165 rpm. However, the 18-in. barrow pulley on the doffer is driven by a 2.25 in. pulley on the lickerin, instead of by the 3.75-in. pulley shown. What is the doffer constant for the card? *b)* What is the draft constant for the same card?
3. *a)* You have a card with a draft constant of 1,581. What draft gear will you use to get a mechanical draft as close as possible to 108? *b)* What will be the mechanical draft with the draft gear you have calculated?
4. The waste on rayon staple is very low; let's say you are making 2% waste. If the mechanical draft is 105.4, what will be the actual draft of the card?
5. Suppose you have found the actual draft of a card to be 107.6. You are feeding  $12\frac{1}{2}$ -oz picker lap. What weight of sliver will the card produce?
6. The doffer constant of a card is 0.267, and you want a doffer speed of approximately 6.5 rpm. What production change gear do you use?
7. The gearing of your card between doffer and coiler is exactly as shown in Fig. 4. The doffer makes 6.4 rpm. You are producing 50-grain sliver at 90% efficiency. How many cards must you run in 3 shifts of 40 hr each to produce approximately 20,000 lb of sliver per week?

### *Setting the Card*

#### Principles of Setting

31. If you are familiar with an automobile, you know that it needs inspecting from time to time. The motor must be tuned



for greatest efficiency, the brakes and lights must be adjusted, and so on. The card also needs adjustments. Most of these consist of setting the parts in correct relation to each other, so the card adjustments are usually called settings. These settings must be changed at intervals to allow for wear. Also, the settings may have to be changed when different stock is carded. After grinding, stripping, or repairing, the settings must again be taken care of.

Accurate setting is a prerequisite of good carding. Most of the adjustments are made in thousandths of an inch, and they have to be just right. Setting is a responsible job, and to be done only by trained and responsible men.

One danger in setting is that the parts may move a little after the setting operation is completed. Suppose, for instance, that you have set the doffer to the cylinder so there is only a 0.005-in. distance between them. If that setting should close up just a little, the wire on the two surfaces would touch. This rubbing of wire against wire is called facing. You can, with a little practice, recognize it by sight, because the wire on the affected surfaces takes on a bright shine. This rubbing together of wires generates heat. This, in turn, causes the glue in the foundation to soften, so that the plies become separated. Therefore, facing in a card must be remedied immediately. The least it can do is to ruin the clothing, at the worst it may cause a card fire and burn down the whole mill. This will not happen if you use the right setting technique.

Practically every setscrew on the card is held by two nuts in a hole in the card frame or in another rigid part. This is illustrated in the section in Fig. 6. In order to move the adjustable part, loosen both nuts. Make the setting tight with the adjusting nut, perhaps a thousandth of an inch tighter than you need. Then tighten the backing-off nut as much as you can. This will open the setting to the point you actually want, and at the same time it will lock the setscrew securely, so it cannot come loose.

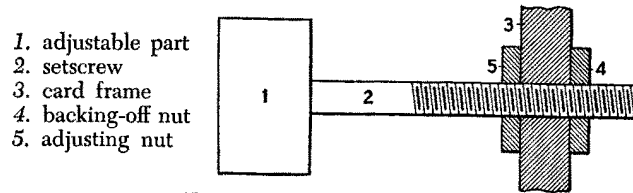

FIG. 6. FUNDAMENTALS OF SETTING

As you study the various settings, you may well ask: "How can a man remember all that?" You are not expected to, at least not for a few years. You'll have check lists. Furthermore, as you go ahead, you'll keep your own records of the results of various settings. However, you should memorize the basic setting technique just described. Settings made in this manner will hold better from one grinding to another. It is a little detail, but one that is very important.

### Card Gauges

32. In order to set the card, you need a set of gauges similar to those shown in Fig. 7. The leaf gauges have numbers showing their thickness in thousandths of an inch. For instance, the No. 7 gauge is 0.007 in. thick. When this gauge fits snugly between two parts, you have a setting of 0.007 in. If the gauge fits tightly, you have a setting of about 0.006 in. If the gauge fits loosely, you have a setting of about 0.008 in. For a setting coarser than 0.012 in., you can combine several of the leaf gauges. If you need a setting of 0.015, for example, you can use the No. 10 and the No. 5 gauges together, because their combined thickness is equivalent to a No. 15 gauge.

You'll realize that these thin gauges are easily damaged. You can't expect accurate settings with gauges that are bent or dented. Furthermore, if you allow a 0.01-in. film of dirt to accumulate between the No. 12 and the No. 7 gauge, you'll get a setting of 0.029 in. instead of the 0.019 in. you want. If you stick the gauges between running card parts, you'll not only ruin the gauge, but you may get your hand chewed off.

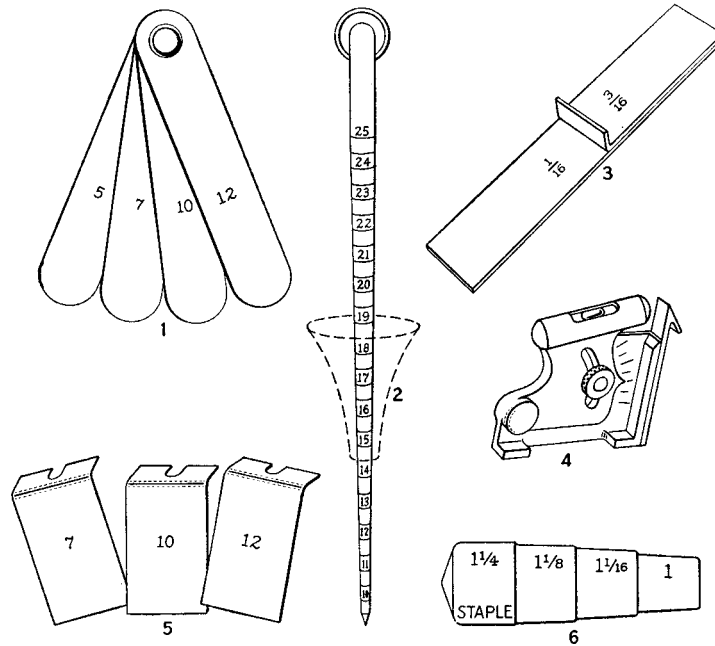

1. leaf gauges      3. screen gauge      5. flat gauge  
 2. trumpet gauge    4. angle gauge      6. step gauge

FIG. 7. CARD GAUGES

The trumpet gauge is used to measure the hole in the trumpet which condenses the web into a sliver. The gauge is inserted into the trumpet as far as it will go. At the last line showing below the trumpet, you can read off the diameter in hundredths of an inch. For example, if the gauge stops at 12, the trumpet hole diameter is 0.12 in.

Trumpets should be gauged about every three months. If the hole is too big, the trumpet must be replaced with a new one. The correct diameter for the hole depends on the sliver being run. A drill may be used to carefully ream out the hole to the proper size. Table 1 shows the hole diameters and the corresponding drill numbers used for common sizes of sliver.

TABLE 1  
COILER TRUMPETS

Sliver in Grains per Yard	Hole Diameter in Hundredths of an Inch	Drill Number
40	14	27
45	15	25
50	16	21
55	$16\frac{3}{4}$	19
60	$17\frac{1}{2}$	16
65	$18\frac{1}{4}$	14
70	19	12

The screen gauge is much coarser than the leaf gauges, its blades being  $\frac{1}{16}$  and  $\frac{3}{16}$  in. thick. It is used to measure the distance between the card cylinder and the screen.

The flat gauges are bent up on one side, so they can be attached to a handle. Because they then look like a tiny garden hoe, they are sometimes called hoe gauges. Like the leaf gauges, the flat gauges are calibrated in thousandths of an inch. They are used for setting the flats to the cylinder.

The angle gauge is hung on the blade of the mote knife. The level on top of the gauge is moved until the air bubble is in the center. The pointer then shows the angle of the mote knife.

The step gauge is used to check the distance between the bite of the calender rolls and the tip of the trumpet. The setting to be used at this point depends on the staple length of the fibers being carded.

#### Aligning the Card

33. Cards that were erected properly on a solid foundation have often given half a century of good service. To get maximum service, the cylinder must be assembled and balanced to perfection by the manufacturer. Furthermore, you must not put the card on a flimsy floor, where it might set up a

vibration which would disturb the settings and wear out the bearings. Don't move the cards around if you can help it. If you must move them, put the moving force on the base of the frame, never on the shafts, cylinder, or arches.

Let's assume that the card frame has been placed on the spot where it is to remain, and that the cylinder is in place. Now place a level on each side of the frame and find the highest corner of the frame. Put temporary chims under the opposite corner on the same side of the frame until one side is perfectly level. Then level the other side. When the card is level on both sides, and also level crosswise in front and back, replace the temporary chims by permanent hardwood chims. Also place chims under each upright member of the frame. Check the level once more, then cut off the protruding ends of the chims. Finally, fasten 1-in. molding wood all around the bottom of the frame. This should be tight, so no air currents can get in to interfere with the currents created by the carding action. Disturbed air currents are often the cause of uneven webs, and they also influence the amount of waste removed by the card.

Check the alignment after the first few times the card has been ground, to see that it has not settled out of line. After that, check the alignment once a year, or more often in buildings where the floor is liable to settle out of line.

#### Arches and Bends

34. The arches, which support the flexible bends, need no adjustments. However, the bends themselves need adjustment from time to time. As shown in Fig. 8 (*a*), an adjustable slide holds the bend to the arch. There are five such slides on each side of the card. As you can see in the illustration, the flats slide on the bends. Since the bends hold the flats at a given height, the positions of the bends determine the distance between the card clothing on the flats and the card clothing on the cylinder. This distance is the flat-cylinder setting.

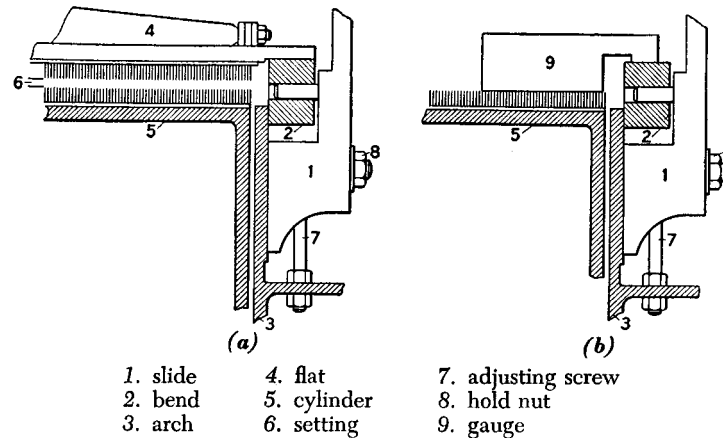

FIG. 8. FLEXIBLE BEND

Before using the adjusting screws, you must loosen the hold nuts which hold the slides in place. A special gauge is used before the flats are put on, as shown in sketch (b), to set the bends at a uniform height above the cylinder. Then put one flat across the card and check with the No. 12 leaf gauge to make sure there is enough clearing. Finer settings can be made later.

After each grinding, the wire clothing on flats and cylinder will be shorter. Consequently, the settings will open up. For adjustment, start at the top of the card. Loosen the hold nuts on the intermediate slides and adjust the settings on the sides. As you set the two lower slides on each side, the intermediate slides will be pulled into the correct position. We'll explain later the details about the adjustment of the flats. Remember though, no matter how setting arrangements on various models of cards may differ in detail, the setting is always made by adjusting the position of the flexible bends.

#### Installing the Flats

35. Flats and chains come in sets, and wherever possible, a set should be kept together. Let's assume that a set of flats

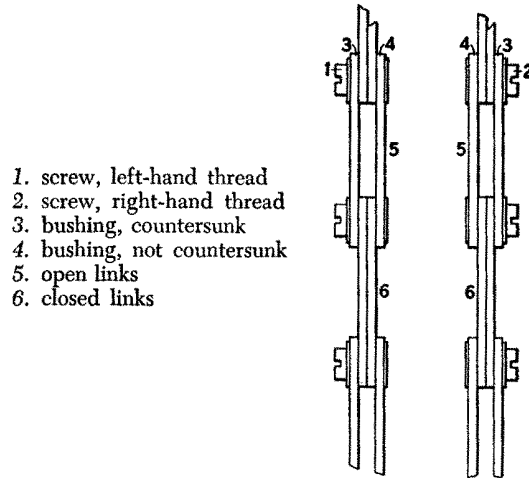

FIG. 9. FLAT CHAINS

has been sent out for clothing and is to be installed. There are several points you should keep in mind while doing this job.

First of all, examine the flats carefully to make sure there is no damage from rust or careless handling. While you are at it, lubricate, with a piece of graphite, the points that will touch the bends. Then examine the chains; clean, dry, and lubricate them. In Fig. 9 sections of the chains are shown, as seen from the delivery end of the card. Soak the screws in light oil, then wipe them. Keep the screws from the two chains separate—they are threaded in opposite directions. In putting the chains together, note that the outside bushings are countersunk, while the inside bushings are not. Make sure that the chains are parallel, that is, an open link on the left chain should be exactly opposite an open link on the right chain. When the chains are properly installed, put a pin into each at the top center stand of the card, so they will stay in place while you install the flats. But first, let's finish with the chains.

A chain must not be too tight; otherwise it will be hard to drive and will wear out quickly. If you have about 1 in. of

play up or down in the middle of a chain between feed end and tightener pulley, the tension for a new chain is right. But don't run a chain so slack that it sags enough at the back carrier pulley to let the flats touch the back plate; if this happens, the wire will be dulled. If the tension pulley has been moved all the way out, and there is still too much slack in the chain, you can take out two links and install an offset link. This will make the chain shorter and will permit you to use it for several more years before replacing it. However, many carders believe that cutting a chain is not good practice. Instead, they recommend having a foundry cast tension pulleys of a larger diameter. You then replace the tension pulleys and leave the chains alone. No matter what adjustments you make, be sure that both sides of the chain are set alike. If they aren't, there may be minor distortions, which will cause a variety of card troubles.

#### Setting the Flats

36. As you have learned, there are five setting points for the flats on the arches at each side of the card. In order to set the flats, you must remove one flat at each one of the setting points. Or, you can omit these flats when you install a new set. The setting flats are about 10 flats apart. The exact arrangement varies on different makes and models of cards. You can get exact instructions as to which flats are the setting flats from the manufacturer; or you can mark the flats while the card is standing still. Then run the card until the setting flats are on top, remove them, and run the card again until the empty spaces are exactly opposite the setting points, as indicated in Fig. 10 (*a*).

Insert in the handle the flat gauge you are going to use. Then put it under the flat next to the setting point, as shown in sketch (*b*). While you are setting the flats, the card is stopped, of course. In theory, you would do a better job if all the machinery in the room were idle, because the vibration



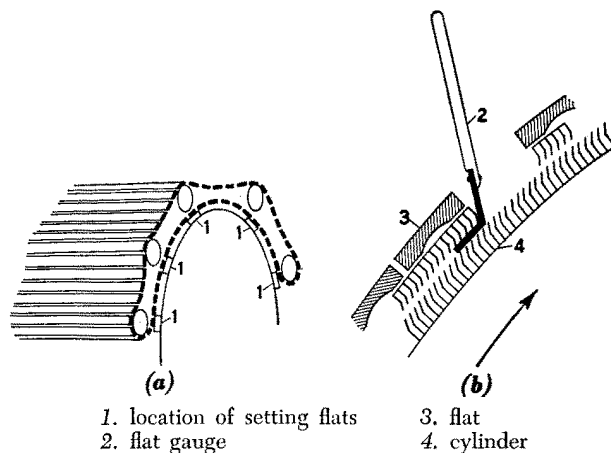

1. location of setting flats  
2. flat gauge  
3. flat  
4. cylinder

FIG. 10. SETTING THE FLATS

interferes with this delicate job. Normally, however, you'll have to set the flats while the mill is running. You must learn from experience how to make allowances for the vibration.

The side of the flat used for setting purposes is the heel. This is about 0.03 in. nearer to the cylinder than the toe. Insert the gauge first between the flat and the cylinder above the central setting point, and make the adjustment.

In setting a flat you can set only one end at a time. With one hand hold the end you are setting firmly in position on its bearings, and with the other hand move the gauge back and forth across the card between the flat and the cylinder. The card is too wide for you to move the gauge the entire length of the flat. Consequently, you must set one end temporarily. Then set the other end. Now test the first end you have set, and also test the other end once more, to make sure that the flat is in the proper position.

When both ends of the central flat have been set, work on the flat at the extreme front of the card. Next, set the flat nearest the rear of the card, and then the two intervening flats. In setting flats you should feel a certain amount of fric-

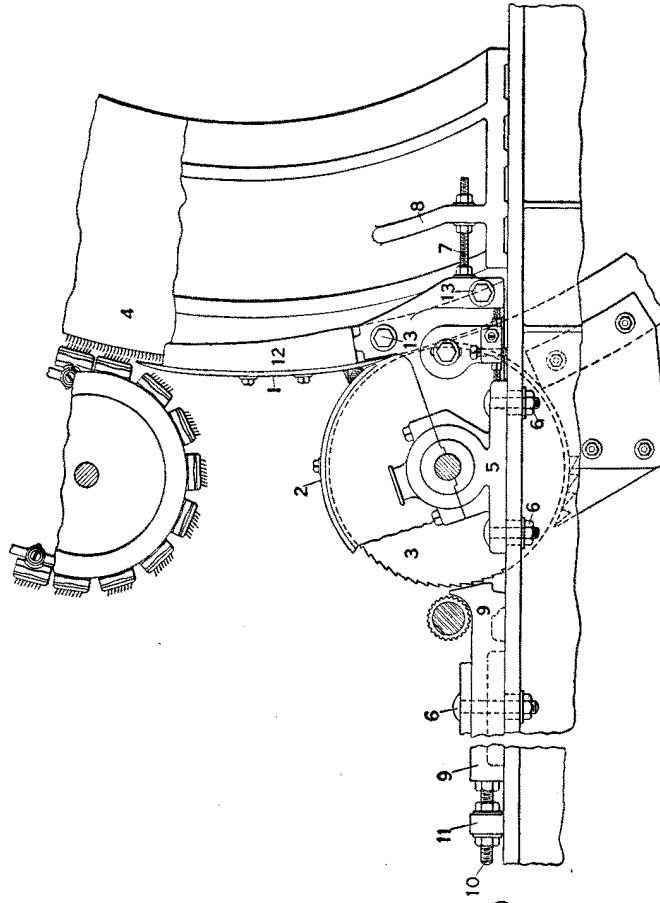

1. back plate
2. lickerin cover
3. lickerin
4. cylinder
5. lickerin bearing
6. retaining screws
7. adjusting screw (lickerin)
8. lug on arch
9. feed plate
10. adjusting screw (feed plate)
11. lug on frame
12. bend segment
13. adjusting screws (back plate)

FIG. 11. SETTING THE LICKERIN

tion, or resistance, as you move the gauge along between the flat and the cylinder.

37. The settings thus far are only temporary settings. After the adjustment of the flats, the slides should be secured, and the settings again tested. Make sure that the proper spaces exist between the cylinder and the flats. Now turn the cylinder slowly, moving the flats at the same time. If there is any rustling sound, you'll know that the wire surface of the flats is contacting the wire surface of the cylinder at some point. You must ease the flats farther from the cylinder at that point.

For normal carding, whether cotton or synthetics, the flats are set about 0.01 in. from the cylinder at the heel of the flat. That is, you use a No. 10 flat gauge. You'll want a little less space near the front of the card than near the feed end. Set the flats at the back very loosely to the gauge. Set those on the top and center consecutively closer. Set the flats near the front very tight to the gauge. Don't forget to make the final settings by tightening all of the backing-off nuts, so nothing can come loose later when the card is running.

#### Setting Lickerin to Cylinder

38. The settings involving the lickerin are important. If the lickerin does not continually feed an even amount of stock to the cylinder, you can't expect the card to produce an even sliver. The first step is to set the lickerin to the cylinder. The parts involved are shown in Fig. 11, but you must remove the lickerin cover, so you can reach in with the gauge.

The lickerin is mounted on movable bearings, which are screwed tightly to the card frame. You must loosen the retaining screws before you can move the lickerin. The adjusting screw for the lickerin is held in a lug on the arch of the card. If you loosen the nuts on the adjusting screw, you can move the bearings by tapping them lightly with a hammer. Or, if the bearings move easily, you can make the adjustments with the nuts—but don't strip the thread on the adjusting screw.

Insert the leaf gauge between the lickerin and the cylinder. Slide it all the way across, to make sure that the lickerin does not touch the cylinder anywhere. Make this setting tight; if necessary, use a finer gauge than the one you actually need. Then tighten the outside nut. Now use the backing-off nut to open up the setting, so nothing can come loose later. The normal setting for cotton and synthetics at this point is 0.01 in., that is, you use the No. 10 leaf gauge. For fine stock you can use a tighter setting, with the No. 7 leaf gauge. Be sure to turn the lickerin and to check the setting all the way across in various positions before you go on to the next setting.

#### Setting Feed Plate to Lickerin

39. While you have Fig. 11 before you, let's see how the feed plate is set to the lickerin. If you set the feed plate too closely, you'll get broken fibers, a great amount of fly, and weakened yarn. If you set the feed plate too far from the lickerin, it will pluck the stock off unevenly. This results in neps and irregular sliver. The correct setting varies according to the weight of the lap and the length of the staple. For instance, a 0.007-in. setting may be all right with a 12-oz. lap, but a 0.015-in. setting would be necessary for a 16-oz lap of similar stock. A 0.01-in. setting is normal for average weight cotton laps. A 0.017-in. setting may be regarded as average for synthetic staple. Check on how the stock runs, and keep a record of the results you get. Then you'll know how to handle similar jobs in the future.

The feed plate rests on the card frame. It is held in place by a retaining screw, which you must loosen before setting. The adjusting screw for the feed plate is held by nuts in a lug on the card frame. Insert the proper leaf gauge between the feed plate and the lickerin. Check all the way across and make the setting with the adjusting nut and the backing-off nut, as you have already learned to do. Remember to use two or more leaf gauges together if you need a wider setting than the thickest gauge you have available.

**Setting the Back Knife Plate**

40. The back plate extends from the lickerin cover to the flats, as indicated in Fig. 11. The back plate is fastened to a bend segment. In the illustration this bend segment is attached to the adjustable lickerin bearing, so it moves with the lickerin when this is set. Or, the adjusting screws shown can be used to set the plate independently. The exact arrangement varies on different cards, but you can always move the top and the bottom of the plate independently of each other, except on some very old cards, such as the Pettee card.

The leaf gauges are used to set the back plate to the cylinder. The top of the plate is set a little looser than the bottom of the plate. A setting of 0.024 for the top will be all right for some stock. However, a wider setting, say 0.029 or even 0.034, is often used on the top edge, especially on synthetics.

**Setting Doffer to Cylinder**

41. As shown in Fig. 12, the doffer also rests on adjustable bearings. Consequently, the technique of setting the doffer is quite similar to that for setting the lickerin. For normal work a setting of 0.007 is used, more or less, depending on the stock you are working with.

If the card web is cloudy, if the cylinder tends to load up, and if the waste contains a lot of good fiber, the chances are that your doffer setting is too loose. If waste fibers and impurities are passed along into the sliver, your doffer setting may be too close. You'll realize that the best setting distance depends on the type of stock you are carding and the weight of sliver you want to produce.

**Setting the Front Knife Plate**

42. A very important setting is that of the front plate, the top of which is often called the stripping plate or the percentage plate. As shown in Fig. 12, this plate reaches from the cylinder door above the doffer to the point where the flats

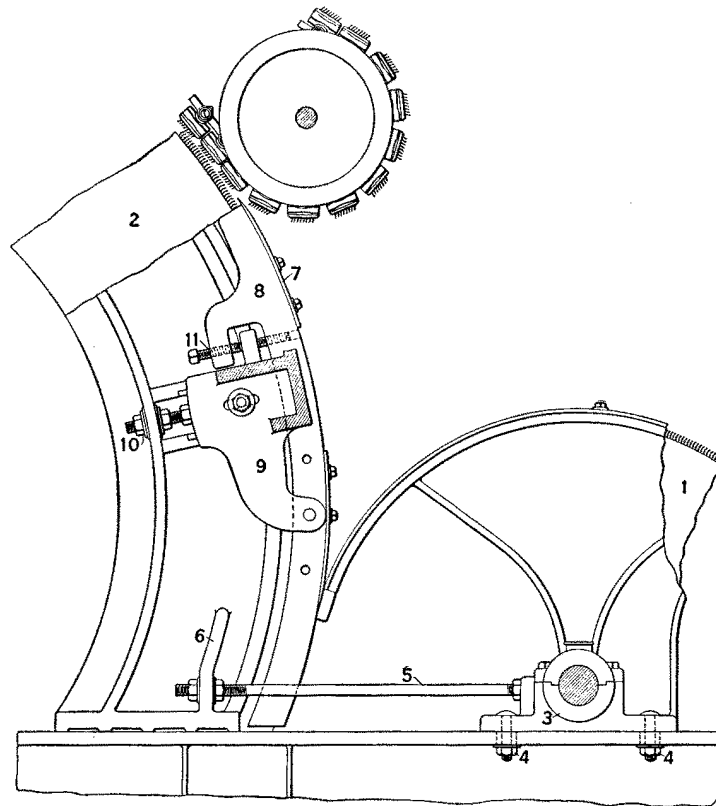

- |                               |                               |
|-------------------------------|-------------------------------|
| 1. doffer                     | 6. lug on arch                |
| 2. cylinder                   | 7. front plate                |
| 3. doffer bearing             | 8. bend segment               |
| 4. retaining screws           | 9. bracket                    |
| 5. adjusting screw (doffer)   | 10. adjusting screw (bracket) |
| 11. adjusting screw (segment) |                               |

FIG. 12. SETTING THE DOFFER

leave the cylinder. The plate not only prevents the formation of air currents at the front of the card, but it also controls the percentage of strips removed by the flats.

In the arrangement illustrated, the plate is fast to a bend segment. Adjustments can be made by moving the bracket on which the segment is carried. There are also setscrews

which permit changes between the bracket and the segment. Specific arrangements vary on different types of cards. In any case, however, the back plate is so attached that you can set the top edge and the bottom edge at different distances from the cylinder.

The leaf gauges are used for setting the front plate. The setting for the lower edge is normally 0.017 to 0.022 in. The setting for the top edge depends entirely on the number of flat strips desired. With clean stock, a setting of 0.024 or even 0.019 in. may be possible. For dirty stock, settings of 0.029 or even 0.034 will be better. The wider the setting, the more flat strippings will be made; that is, if your setting here is too loose, you'll waste good fiber. If you make the setting too tight, short fibers and dirt will be taken from the flats and carried around by the cylinder. In short, you must arrive at a setting that will neither make excessive waste nor produce inferior sliver.

#### Cylinder and Lickerin Screens

43. The exact arrangement of lickerin and cylinder screens differs somewhat in different makes and models of cards. In all models, however, the two screens are so attached to each other that you can set them accurately. Most cards are built so that the lickerin screen will be in the right position if you set the cylinder screen accurately. In case of doubt, get specific instructions from the manufacturer of the card. The front edge of the lickerin screen is usually set about 0.012 in. from the lickerin. The nose, on the point of the lickerin screen with which the fibers first come into contact, is usually set 0.034 in., but sometimes as much as  $\frac{1}{8}$  in. (0.125), from the lickerin wire. The looser this setting is made, the more fly will be made. That is, you will remove more short fibers from the stock.

The cylinder screen is set farther from the cylinder in the front than in the back. The setting in the back, or next to the lickerin screen, should be about 0.029 to 0.034 in. In

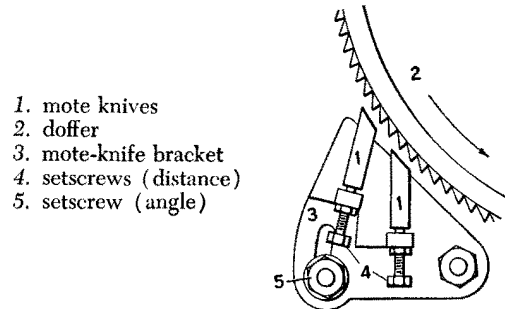

FIG. 13. MOTE-KNIFE ASSEMBLY

the case of synthetics you may go lower, say to 0.022 in. At the bottom the screen is set about 0.034 in. from the cylinder, or a little looser than that. At the front, or doffer end, the setting of the screen to the cylinder is very open. A setting of  $\frac{3}{16}$  in. (0.19) is commonly used. This wide setting prevents the ends of fibers that stick out of the cylinder clothing from contacting the edge of the screen and thus being removed as fly.

#### Setting the Mote Knives

44. In most settings you have to consider only one problem: to find the right distance between two parts. While there are some ancient cards in which the mote knives too are only adjustable for distance, modern cards have the mote knives arranged so that the angle can also be adjusted, more or less as shown in Fig. 13. The mote knives are held in a bracket below the lickerin. An adjusting screw permits each knife to be raised or lowered, so you can set the knives at the proper distance from the lickerin. Another setscrew in a slot of the bracket permits you to set the knives at any desired angle to the lickerin. As you'll see, this angle is important.

In order to set the angle, set the angle gauge at the desired angle, say 20 deg (degrees). Now hang the angle gauge on the edge of the top mote knife. Move the mote-knife bracket until the air bubble on top of the gauge is centered. Then



tighten the bracket firmly. The degree at which the knives are set varies from 13 to 30 deg. As you increase the angle, that is, move the knives down from an upright position into a more slanting position, more fly is made. In other words, if you want to remove as many burs, neps, and tangled fibers as possible at this point, increase the angle. If you don't want too much waste taken out by the mote knives, decrease the angle.

After the angle is set, you can set each of the knives at the correct distance from the lickerin. Depending on the needs of the stock, the settings are varied; 0.015 in. may be considered average. Some carders set both knives at the same distance. Others set the bottom knife a little closer, because the top knife can then catch the bigger motes and the bottom knife the remaining motes. For synthetics the knives should be set as close as practicable, since there are no burs, but only little neps or nits to remove. As with other settings, it is a good idea to keep records of results, so as to save future experimentation.

#### Setting the Doffer Comb

45. You can set the distance between doffer and doffer comb with a leaf gauge in just about the same way that you set most of the other settings. The comb is mounted on sliding bearings, which you can move with setscrews. If you set the comb too close, it will scratch short waste stock, motes, and burs out of the doffer wire and will transfer this trash into the web. Furthermore, the comb may contact the doffer wire, damaging both surfaces. If you set the comb too loosely, the doffer will load up and the web will become uneven. Doffer comb settings range from 0.007 to 0.022 in. A setting of 0.01 for cotton, and 0.017 for synthetics, may be considered average. Be sure to look at the web though, and adjust the setting as needed.

The sweep, or position of the comb stroke, is also adjustable. This adjustment is made in the comb box, by altering

the relative positions of the comb and the eccentric from which it receives its motion. If the web is reasonably tight, and moves smoothly to the calender rolls, the stroke is set right. If the web tends to sag, raise the stroke. If the web tends to break, lower the stroke. The decision on how to make this setting is not a difficult one, because one look at the web will show you whether it is correct, sagging, or breaking.

### Setting the Brushes

46. Last, but not least, you must set the brushes that keep the flats clean. Set the large spiral brush above the flats so that its bristles can reach into the flat wires and clean out the waste. Don't set it so deep that the bristles ruin the foundation of the wire, or that they push the dirt down instead of sweeping it out. When the bristles reach just about to the knee of the wire, the brush is set right. Then set the hackle comb that strips the brush so that its tines reach about  $\frac{1}{2}$  in. into the bristles of the spiral brush.

Finally, check the various small brushes that keep the flats and the chain brushed off. They must perform their jobs; otherwise everything will become clogged with lint, and wear out.

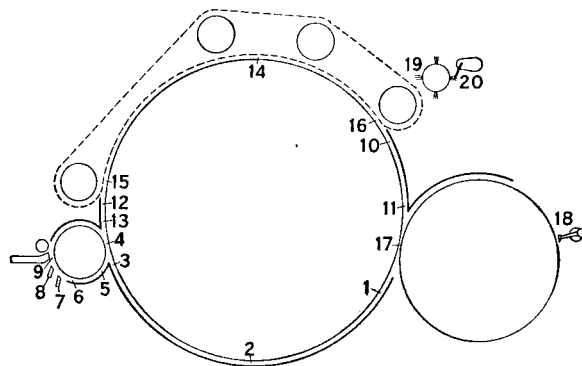

FIG. 14. LOCATION OF SETTINGS

TABLE 2  
AVERAGE CARD SETTINGS

No.	Setting Point	Distances in Thousandths of an Inch	Remarks
1	Screen—cylinder (front)	190	
2	Screen—cylinder (center)	58	Varies in different makes of cards
3	Screen—cylinder (back)	29	
4	Lickerin—cylinder	10	No. 7 for fine stock
5	Screen—lickerin (front)	29	
6	Screen—lickerin (back)	125	
7	Bottom mote knife—lickerin	15	Also set angle, 18 degrees
8	Top mote knife—lickerin	17	Change according to stock
9	Feed plate—lickerin	10	
10	Back plate—cylinder (top)	29	
11	Back plate—cylinder (bottom)	24	
12	Front plate—cylinder (top)	24	Check strip percentage
13	Front plate—cylinder (bottom)	19	
14	Flats—cylinder (center)	10	Remember intermediate setting points
15	Flats—cylinder (back)	11	No. 10 gauge, loose
16	Flats—cylinder (front)	9	No. 10 gauge, tight
17	Doffer—cylinder	7	Watch card web
18	Doffer comb—doffer	10	Also set sweep
19	Spiral brush—flats	...	Set to knee of wire
20	Strip comb	...	Set ½ in. into brush
21	Coiler trumpet (diameter of hole)	...	Depends on sliver run. See Table 1

### Check List for the Settings

47. Since there are so many different settings on the card, it is a good idea to make up a check list. On top of the list, put the make and model of the card. Then put down the exact type of material you are running, whether cotton or synthetics. Leave room so that later you can mark down the waste percentage, the results of sliver and yarn tests, and so forth. If you fill out such lists for every card you set, you will eventually have an excellent file of reference data. All we can do here is to give a list in Table 2 which you can use as a guide. Remember that the settings given are just average settings. You'll have to determine your own for specific cards and specific jobs. For quick reference, the locations of the settings are marked in Fig. 14. Numbers 1 to 20 on this sketch correspond to the numbers in the table.

Since the lickerin must be set to the cylinder, this setting must be made before you can set the mote knives to the lickerin. The order of settings given in Table 1 is arranged so that you can follow it without having to repeat any settings. If you check off each setting as you make it, you'll be certain of not having omitted any. The check-off system is particularly useful when the setting of the card is started on one shift and completed by someone on the next shift.

### Roller-Top Cards

48. The settings for roller-top cards built on the same frame as revolving-top cards are not difficult. Of course, the exact settings change with the weight of the lap and with the stock used, but most settings are just about the same as those we have already discussed. Of course, instead of setting the flats, you must set the rollers.

First, set each worker to the cylinder. The normal setting is about 0.01 in., or No. 10 gauge. Just as in setting flats, you should set the workers near the back of the card a little looser, and the workers near the front a little tighter.

When the workers are set, adjust the strippers two ways. First, set the stripper to the cylinder. Then set the stripper to the worker. The normal distance is 0.01 in. for both settings. However, if the strippers tend to load up, set them a little wider from the workers, up to about 0.017 in. Keep in mind that setting the rollers accurately takes longer than just reading about it. Remember to turn the rollers a little and check again and again, to make sure the carding surfaces don't touch anywhere.

### Card Production

49. As we'll see, the best speed and production of a card are debatable. At this point we'll look at common practice. Later, we'll look at some experiments deviating from this practice. In general, the production of the card depends on two factors: 1) the stock you work with, and 2) the requirements of the yarn. If you use coarse stock for low counts of yarn, you can card faster. But if you want to spin fine numbers from long staple cotton, or if you work with synthetics, you must slow down.

A card production guide, as recommended by Saco-Lowell for 40-in. cards, is shown in Table 3. This table is based on production per hour. Other tables are often based on 10 hours, because many mills once worked a 10-hr day. If you work with such a table, simply adjust the figures.

EXAMPLE. A production table, based on a 10-hr day, shows 90 lb as the production of a card. How many pounds will the card produce when you run it three shifts of 40 hr each?

SOLUTION. 
$$\frac{90 \times 40 \times 3}{10} = 1,080 \text{ lb per week. Ans.}$$

When you run synthetics on revolving-flat cards, the production is more or less the same as on cotton. A production of 7 to 8 lb per hr may be regarded as average. Roller-top cards produce at least twice as much; production figures of 25 lb per hr are often reached.

TABLE 3  
CARD PRODUCTION

GRADE AND STAPLE OF COTTON	KINDS OF GOODS	COUNTS OF YARN	CARD PRODUCTION IN POUNDS PER HOUR	
			Average Work	Quality Work
$\frac{3}{4}$ to 1 inch Strict low middling to strict good ordinary	Twines, coarse yarns, carpet warps, ducks and Osnaburgs, insulating yarns.	4 to 12	11 to 14	9 to 11
$\frac{5}{8}$ to 1 inch Middling to strict low middling	Heavy sheetings and drills, coarse knitting yarns. Ordinary industrial fabrics. coarse tire yarn.	12 to 20	10 to 12	8 to 10
1 to 1 $\frac{1}{8}$ inches Low middling to strict middling	Knitting yarns, converters' goods, print cloths, fine twills, medium tire yarns.	20 to 30	8 to 10	6 to 8
1 $\frac{1}{8}$ to 1 $\frac{3}{8}$ inches Middling to strict middling	Carded shirtings, fine convertibles, shade goods.	30 to 50	7 to 10	5 to 8
1 $\frac{3}{8}$ to 1 $\frac{1}{2}$ inches Middling and better	Combed yarns for knitting, mercerizing, and weaving.	30 to 70	5 to 8	4 to 6

In general, high production is desirable only when it can be obtained without lowered quality. It does not pay to save a few minutes in carding if, in doing so, you take a chance on bad yarn, lost time in spinning and weaving, and faulty goods. We'll see later how the quality of carding can be accurately controlled. But first you must study card maintenance, especially stripping.

### *Stripping and Maintenance*

#### **Development of Stripping**

50. Perhaps the most troublesome problem in carding is the necessity for stripping. Stripping the flats is taken care of fairly well by the flat-stripping comb and the spiral brush. This leaves the cylinder and the doffer. We will look at various methods, beginning with the simplest, that have been adopted to accomplish stripping.

Stripping was first done by hand. This is not done any more because it is not only slow, but also extremely dangerous. The hand method consisted of using a hand card made by tacking a piece of card clothing to a rectangular-shaped board. The card was drawn over the surface of the card cylinder and the doffer, and the wire teeth on the hand card combed the embedded fibers from the clothing of the cylinder.

Now consider the economics of stripping. The card tender goes along the alley in front of the card to gather the flat strips. These are taken, usually by a suction conveyer system, to the waste room. Then the card has to be stripped—usually twice every 8-hr shift. This amounts to one stripping for every 50 lb of sliver on fine work, or one stripping for every 100 lb of sliver on coarse work. No wonder then, that a power-driven stripping roll had replaced the hand stripping by the beginning of the twentieth century. Let's see how such a stripping roll operates.

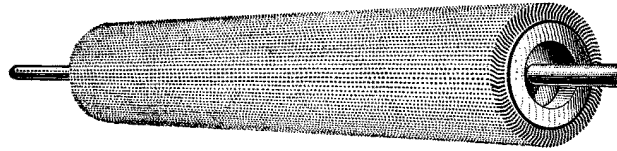

FIG. 15. STRIPPING ROLL

### Roll Stripping

51. A stripping roll, as shown in Fig. 15, is slightly longer than the width of the card. Steel shafts project from both ends to support the roll, which is driven by a grooved pulley keyed to one of the shafts. The stripping roll is covered with card clothing similar to that used on the card cylinder, except that it has much longer teeth and they are not set so close together. Brackets bolted to the framework of the card act as bearings. One set of brackets support the stripping roll in such a position that the wire on it comes in contact with the wire of the card clothing. Another set holds it in contact with the doffer.

To stop a card for stripping means a reduction in the amount of sliver produced. Plan carefully so that the card will not be stopped any longer than necessary while it is being stripped, and so that you can get it in operation again immediately after stripping. In stripping cards, two men are needed to handle the long stripping roll. Time can be saved by having one man prepare the next card for stripping, while the other man restarts the card previously stripped and removes the strippings from the stripping roll. You can strip the cylinder before stripping the doffer, and start the feed while the doffer is stripped. Then, the cylinder will be filled and the sliver can be pieced as soon as stripping is completed. In order to reduce the amount of strippings removed from the card, the feed roll should be stopped a short time before the card is stopped. This allows the good cotton to run through the card and drop on the floor in front of the doffer; it is then returned to the mixing room.



52. Stop the feed roll by disengaging the side shaft at the doffer. Also, stop the coiler assembly by means of the switch gear in the gear train between calender rolls and coiler calender rolls. As soon as the good cotton has run out, stop the card by shifting the belt to the loose pulley. Lower the door in the front plate, so as to leave the cylinder bare at that point. Place the stripping roll into the top set of bearings. Run a band from the outer groove of the loose pulley of the card to the grooved pulley on the end of the stripping roll. Cross the band in order to give stripping action to the roll. With the stripping roll in this position, its teeth should project about  $\frac{1}{8}$  in. into the wire of the cylinder. At the point where the roll is in contact with the cylinder, the teeth of both must point in the same direction. The surface speed of the roll must be greater than that of the cylinder to make the stripping possible.

Now move the driving belt of the card partly onto the tight pulley. Move it just enough to turn the cylinder slightly, but leave enough of the belt on the loose pulley to give power to drive the stripping roll. Make sure that the cylinder surface does not move faster than the roll; if it does, the waste will be taken from the roll by the cylinder.

After the cylinder has made one complete turn, remove the band that drives the stripping roll. Remove the stripping roll, clean it, and place it in the lower set of bearings, at the doffer. Run a crossed band, somewhat longer than the one previously used, from the loose pulley of the card to the grooved pulley on the stripping roll. Strip the doffer in the same way as the cylinder.

53. After stripping the card, the strippings must be removed from the stripping roll. A stripping box is used to strip the roll. This box is about 18 in. wide, 3 ft deep, and long enough for the clothed part of the stripping roll to rest between its ends. The ends of the shaft rest in V-shaped grooves in the ends of the box. A strip of wood about 4 in. wide, covered with card sheets, is fixed below the stripping roll so that the

wire teeth of the roll will just enter the wire of the sheets. To clean the roll, turn it by hand with a backward and forward movement. This causes the strippings to be removed and dropped into the box.

Remember that a card, immediately after stripping, produces a sliver slightly lighter in weight until the clothing fills up again with fiber. If you want to make even yarns, you can't strip, all at the same time, all the cards that supply the next machine, but must take them in sections of two or four, supplying different machines.

During roll stripping, a lot of fly and dust is thrown into the air. This makes for such unhealthy working conditions that workers often wear respirators. The dust settles on other cards, causing dirty slivers and clogged machine parts. In short, roll stripping is a dangerous and messy operation, and it costs time too. Let's look, then, at some better methods that have been developed. Some of these are designed to make stripping safer and less offensive from the viewpoint of eliminating dirt. Others try to do away with intermittent stripping entirely. Roll stripping, however, is still used to give the card a thorough cleaning before grinding and overhauling.

#### **Portable Vacuum Stripper**

54. You know how a vacuum cleaner works. It has a fan inside which sucks in the air through a nozzle. The dirt is held in a bag, while the air escapes. Much the same principle is used to do away with the fly and dust in a portable vacuum stripper.

Essentially, the portable vacuum stripper, Fig. 16, consists of an ordinary stripping roll covered with a metal hood. A flexible tube is attached to the hood, and runs to a fan which exhausts into a waste bag for separating the cotton waste from the air. The portable vacuum stripper shown is mounted in a box on casters. To the right and left of the mechanism, the box has empty spaces where the strips can be stored until

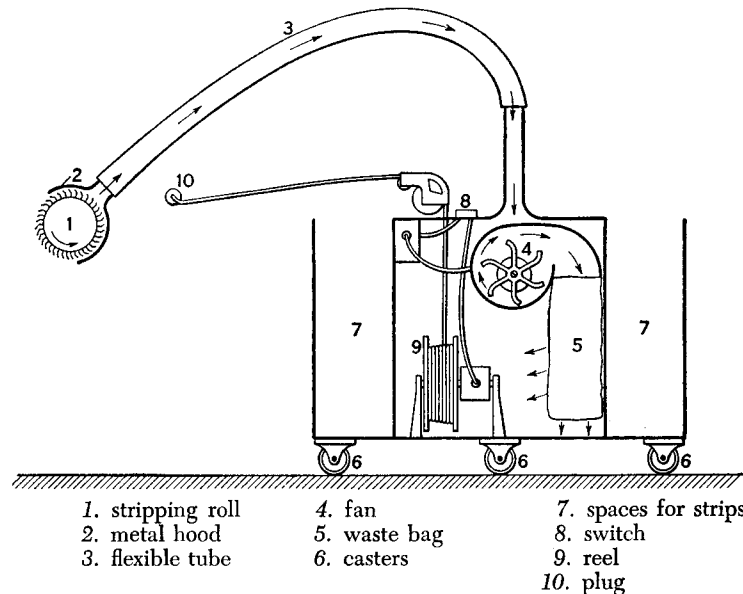

FIG. 16. PORTABLE VACUUM STRIPPER

they can be disposed of. The little electric motor that drives the fan is connected to a switch to stop and start it. A long electric cable is stored on a reel, and the cable can be pulled out and plugged in at the nearest outlet. The stripping roll must be cleaned just as in roll stripping. The stripping box for this purpose can be mounted on top of the unit.

The portable vacuum stripper does little to save labor costs. However, it effectively does away with the fly and dust of ordinary roll stripping. Furthermore, it is an inexpensive unit. It also retains the burnishing action of the stripping roll on the card wire, which some carders believe to be helpful in keeping the wire in condition.

#### Brush Vacuum Stripping

55. With mounting labor costs, many mills looked for a more automatic stripping device. The Saco-Lowell vacuum stripper was designed to retain as many of the good features

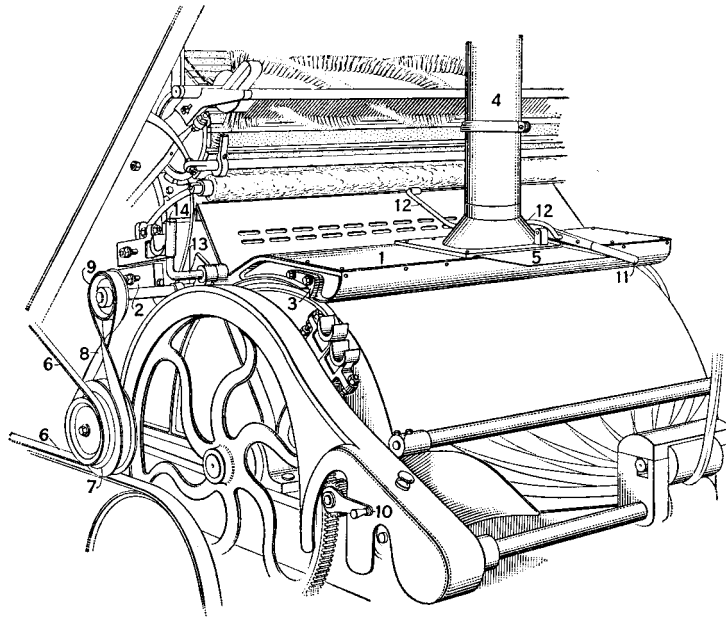

- |                          |                          |
|--------------------------|--------------------------|
| 1. casing                | 8. flat belt             |
| 2. bracket               | 9. stripping-roll pulley |
| 3. adjustable projection | 10. switch-gear handle   |
| 4. vacuum pipe           | 11. door lever           |
| 5. door                  | 12. connecting rod       |
| 6. band                  | 13. stripper rod         |
| 7. compound pulley       | 14. stripper handle      |

FIG. 17. SACO-LOWELL VACUUM STRIPPER

of the portable stripper as possible, but to do away with carting a stripper around. It is mounted permanently on each card instead of being a separate unit.

As shown in Fig. 17, the stripper consists of a casing mounted on the card. The casing contains a stripping roll. Casing and roll act as one unit. That is, the roll is free to rotate within the casing, but the casing and the stripping roll must be moved together when it is desired to change the position of the roll. Special brackets are fastened to each side of the card framework to help support the unit. The bearings holding the stripping roll in the casing are held in the brackets,

and have a limited horizontal motion. The portion of the casing over the doffer is supported by adjustable projections that rest in notches on the card frame. The casing contains a chamber with one end connected to the vacuum pipe. The other end of the chamber tapers to a long narrow nozzle, with an opening about 1 in. in diameter located next to the stripping roll and extending the width of the stripping roll. A door at the lower part of the pipe is used to close the vacuum connections.

56. When you install a Saco-Lowell vacuum stripper, several alterations must be made on the card. The front plate must be changed and connected to the door in the pipeline. When the door closes the vacuum connections, the front plate is closed to prevent stray air currents from interfering with the carding action. But when the vacuum connections are opened, the front plate will be removed, exposing the card clothing. The stripping roll is driven by the main driving pulley. A circular band fits into the groove on the outside of the loose pulley and drives the compound pulley. A flat, crossed belt runs between this pulley and the pulley on the end of the stripping roll.

Two forms of stripper installation are available. One form has all the vacuum pipes connected to overhead pipes that run the full length of the card room. The pipes lead to one main vacuum pipe, which is connected to a condenser and a fan. The condenser, similar to the condensers used in trunk lines in the opening and picking rooms, separates the cotton waste from the air, while the fan exhausts this air into the dust chamber. The other form has all the vacuum pipes located beneath the card-room floor. This eliminates all overhead pipes, which clutter up the room and collect dirt.

57. The operation of the Saco-Lowell vacuum stripper is very simple. Disengage the side shaft, to stop the feed rolls. Move the switch gear, Fig. 17, by means of the handle, to stop

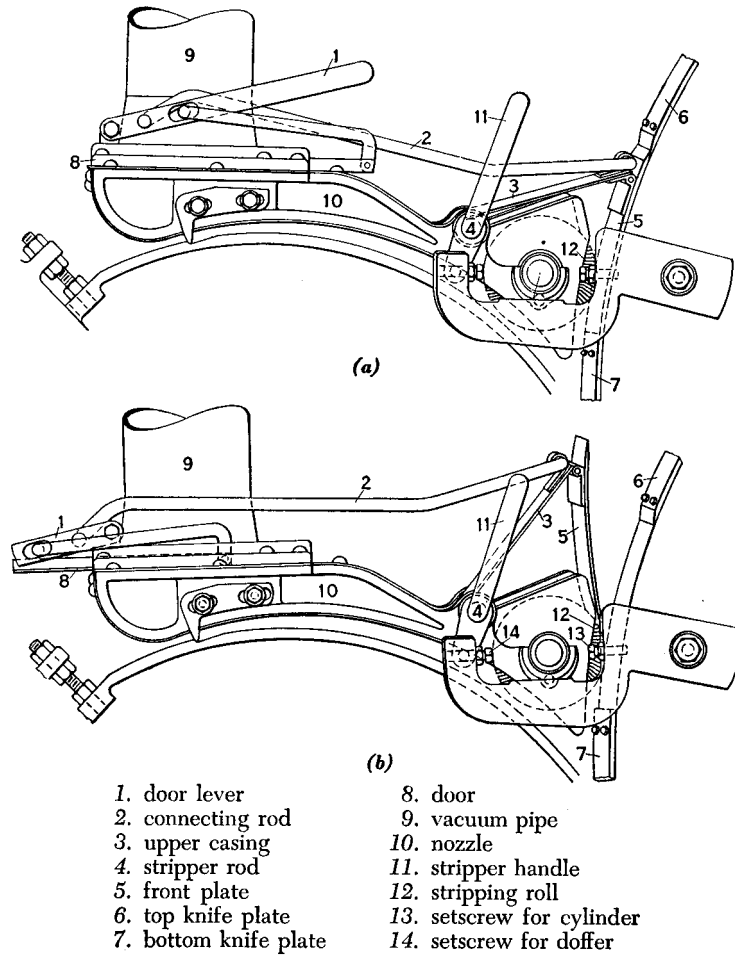

FIG. 18. OPERATION OF STRIPPER

the calender rolls and the coiler. The cotton that is in the card will be combed from the doffer to the floor in web form. The web is returned to the picker room to be reworked. When the card has been cleared, place the band around the loose pulley and the compound pulley. Move the main driving belt to such a position that it will run partly on the loose and

partly on the tight pulley. Make sure that the compound pulley and the stripping roll revolve rapidly, and that the card cylinder turns slowly.

The door lever, Fig. 17, is connected to the door in the vacuum line and, through a rod, to the upper part of the stripper casing. Normally, when the stripper is not in operation, the lever is in a forward position. If you push the door lever backward, the connecting rod pulls the upper part of the casing with it, causing it to rotate around the stripper rod about which it is hinged.

Now let's look at the details of the section, Fig. 18 (*a*). The front plate is hinged to the top of the stripper casing, so that it rests in its normal position against the top and bottom knife plates when the door lever is in the position shown. When you push the lever back, as in view (*b*), it will raise the cylinder plate upward and out, leaving the cylinder wire exposed. At the same time, the lever also moves the door outward, opening the vacuum connections between the vacuum pipe and the nozzle.

The stripper rod extends the full width of the stripping unit. When you push the handle on the stripper rod forward toward the card cylinder, the stripping roll will come in contact with the teeth of the card cylinder. The teeth of the rapidly running stripping roll pull the matted fibers from the clothing of the cylinder. As the stripping roll turns, the waste material removed by the roll passes by the nozzle, and a strong suction, concentrated over a small area by the nozzle, draws the matted cotton from the stripping roll. The strippings are carried through the nozzle, up the vacuum pipe, and through the line to the condenser.

Allow the cylinder to revolve a full revolution or more, in contact with the stripping roll, before pulling the stripper handle backward to bring the roll in contact with the doffer. The teeth of the stripping roll will mesh with those of the doffer, and strip it in the same manner. Return the stripper

handle to its central position after the doffer has been completely stripped. Remove the band from the loose pulley. Close the cylinder plate and vacuum pipe door.

Adjustments are provided for regulating the distance that the teeth of the stripping roll enter between the teeth of the cylinder and the doffer. One setscrew controls the cylinder, and another setscrew controls the distance the teeth penetrate into the doffer clothing.

58. The permanent vacuum stripper has several advantages. Superior stripping is obtained because of the partial elimination of the human element in stripping operations. For instance, when an urgent schedule of stripping is to be carried out with portable rolls, the operative may not strip each card thoroughly. This means that some matted fibers are not removed from the card clothing, and poor sliver may be produced. With the Saco-Lowell vacuum stripper, it is only necessary to move a lever to bring the stripping roll in contact with the card clothing, thus eliminating much of the manual work from stripping.

An important item is the saving in labor afforded by the Saco-Lowell vacuum stripper. Ordinarily, to perform roll stripping, two men are required. With the Saco-Lowell stripper, one operative can strip a great number of cards.

#### Vacuum Stripping

59. All the stripping systems you have studied so far have used a stripping roll. The stripper produced by the Abington Textile Machine Works dispenses with the stripping roll. It is, in principle, nothing but a large industrial version of the vacuum cleaner used by the housewife to clean rugs and furniture. Various adaptations of the Abington system are in fact used for collecting waste throughout the mill. We'll start by looking at a specific installation for cards.

As shown in Fig. 19, brackets are attached on the card frame at the doffer end to support the vacuum stripping unit.



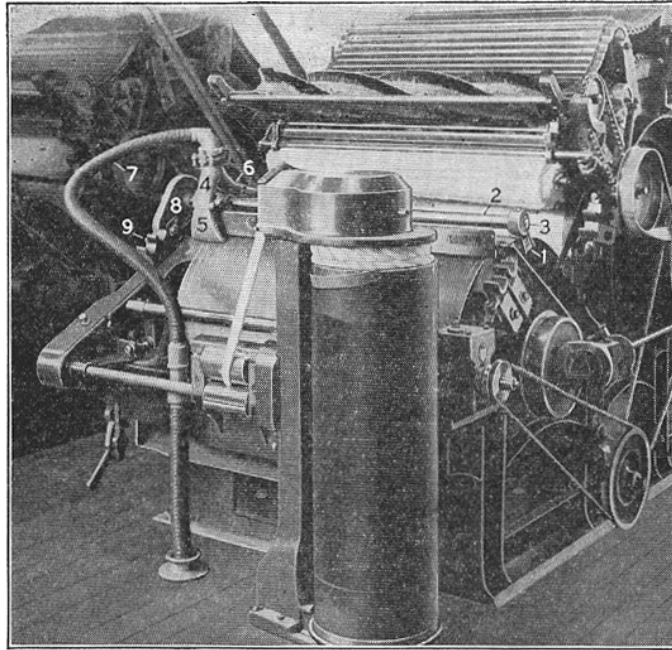

- |                       |                    |                        |
|-----------------------|--------------------|------------------------|
| 1. supporting bracket | 4. nozzle assembly | 7. flexible tube       |
| 2. shell              | 5. front nozzle    | 8. gear casing         |
| 3. shaft              | 6. back nozzle     | 9. disconnecting lever |

FIG. 19. ABINGTON VACUUM STRIPPER

A shell is held in these brackets. A shaft revolves inside the shell. The shaft has a thread cut into it, in which a cog from the nozzle assembly rides. When the shaft turns, the nozzle unit slides on the shell from one side of the card to the other and back again. That is, the nozzles have a traverse motion extending across the width of the card. The front nozzle is about  $2\frac{1}{2}$  to 3 in. wide. It is attached to the nozzle assembly and held close to the doffer wire. The back nozzle, which is only partly visible in the illustration, is about 1 to  $1\frac{1}{2}$  in. wide. It slides in a slot in the plate at the front of the cylinder. A flexible tube connects the nozzle assembly with the vacuum pipes leading to the central station.

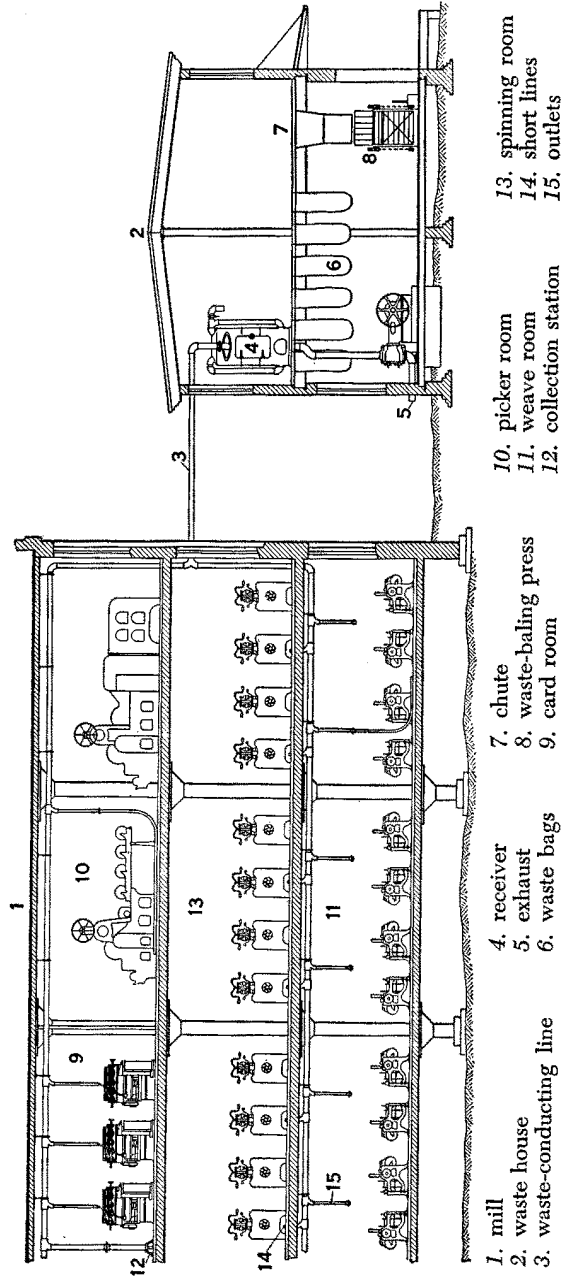

- 1. mill
- 2. waste house
- 3. waste-conducting line
- 4. receiver
- 5. exhaust
- 6. waste bags
- 7. chute
- 8. waste-baling press
- 9. card room
- 10. picker room
- 11. weave room
- 12. collection station
- 13. spinning room
- 14. short lines
- 15. outlets

FIG. 20. INSTALLATION OF WASTE-COLLECTION SYSTEM

As we have seen, the nozzle assembly receives its traversing motion from the shaft. This shaft has a gear at its end. This gear is enclosed in a gear casing, which is shown in the illustration. An opening is cut into the casing of the large gear on the doffer. An intermediate gear, also contained in the casing shown in the illustration, connects the large doffer gear with the gear on the end of the shaft of the stripper. Thus the doffer gear drives the traverse motion of the stripper. The gear casing can be lifted by means of a small lever, barely visible in the illustration. When the casing is lifted, the intermediate gear gets out of mesh with the large doffer gear, and the traverse motion stops.

60. To operate the Abington vacuum stripper, stop the feed in the same manner you learned in connection with other stripping systems. Connect the nozzle assembly to the vacuum line. Lock the lever to mesh the driving gears of the stripping mechanism with the large gear on the doffer shaft, thus setting the unit in operation. The nozzles will slowly traverse across the width of the card while the cylinder and doffer revolve at their normal speeds.

The stripping mechanism is so geared and adjusted that, as the nozzles move slowly across the width of the cylinders, a section of card clothing that has not been stripped will always be under the nozzles. It is desirable that the nozzle slightly overlap the section already stripped, to insure efficient removal of all waste. The strong air suction draws out practically all the embedded fibers, fly, and dirt that have accumulated in the card clothing. The central station in this system of vacuum stripping makes use of a receiving chamber, which we'll discuss presently. A vacuum pump operated in conjunction with it provides the high vacuum, or suction, required.

#### Waste Collection

61. The Abington stripping system is often referred to as a triple vacuum system because of the three purposes for which

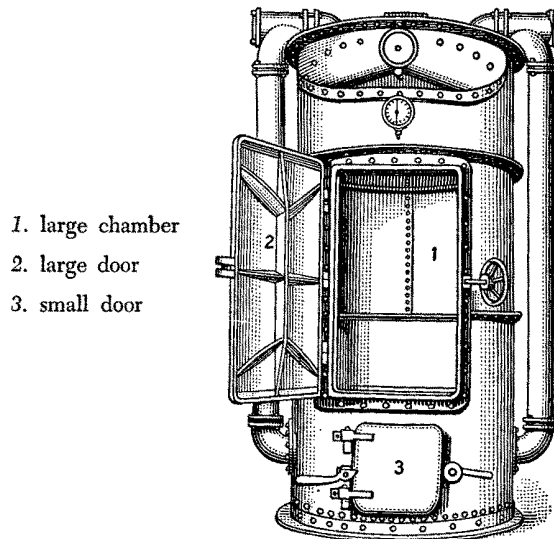

FIG. 21. WASTE RECEIVER

it may be used. The system may be used for card stripping, for waste collection, or for cleaning machinery, or for a combination of these three functions. A mill equipped to obtain full advantage of these features is shown in Fig. 20. You'll notice that the illustration shows an old-fashioned three-floor mill building. We have selected this because the diagram of a modern single-floor mill would cover three pages in the text. You can easily visualize the machinery and vacuum lines alongside each other instead of on top of each other.

The waste house is often a separate building, although this is not necessary. The conducting pipe connects the waste house with the mill. Generally, the waste house is placed near the mill because the waste is difficult to draw for more than 1,000 ft. The waste drawn through the conducting pipe is deposited in the receiver. The air is drawn through the receiver to the vacuum pump, from where it is exhausted outside.

The receiver is shown in detail in Fig. 21. The waste material enters the receiver at the top, and is deposited in the large chamber. This chamber will hold almost a bale of waste, making frequent cleaning unnecessary. The large door permits quick removal of the cotton waste collected. Grates are placed in the chamber at about the door level to allow the dirt and dust sucked along with the cotton waste to be separated from it and to drop into the dirt chamber below. The small door is used for cleaning the dirt chamber.

Usually, bins are built along the walls close to the receiver to hold the various grades of collected waste, until there is enough for baling. In another arrangement, shown in Fig. 19, openings in the floor are provided for holding waste bags. The waste is simply dumped into the bags for further handling. A chute in the floor allows waste to be fed directly to the baling press. If the waste is to be sold, it is baled for transportation.

62. In the installation shown in Fig. 20, a suction pipeline runs along the top of the card room and picker room. Another pipeline runs along the ceiling of the weave room. Both lines are connected to the waste-conducting pipe. As you have learned, this arrangement is hard to keep clean. In new installations the pipelines are usually put under the floor.

No matter where the lines are located, flexible tubes connect the card-stripping assemblies to the lines. Also, a waste-collection station is usually located in the card room. All waste matter—flat strips and the like—that is not removed by the vacuum stripper is collected at this point. From time to time the waste is dispatched through the collection system to the waste receiver. A collection station consists of a large vacuum pipe extending to the floor, with its opening arranged to suck the piles of loose waste through the system to the receiver. This method can handle all the waste in the card room.

The pipeline going to the picker room removes waste from beneath the pickers. The short pipelines extending through the floor of the spinning room are fitted with detachable airtight covers. Whenever the spinning frames are to be cleaned, a flexible tube is snapped on to the end of one of the short pipelines, which is connected to a suction pipe, and a nozzle on the end of this tube is used to clean the machine and the floor. Vacuum has an advantage over compressed air for cleaning, because it removes all lint and fly to a central receiving station, whereas compressed air simply blows the fly around. The system may be applied to the weave room by connecting flexible tubes to the outlets that extend from the pipeline.

If you have a definite schedule of cleaning operations, waste of certain classes will be sucked to the receiver without mixing. The segregation of waste increases its sales value. Also, suitable waste can be reprocessed.

As far as the card room is concerned, one man can strip about 200 cards twice on each shift. But how does the all-vacuum system compare to the brush-vacuum system? Just listen to two housewives argue about vacuum cleaners with brushes as compared to vacuum cleaners without brushes—you can take it from there. When everything is said, you go right ahead with the system that you like best. Either vacuum system is a world of improvement over the old-time stripping roll.

#### Carding without Stripping?

63. While stripping has been much improved, it still has two disadvantages: 1) the card production is interrupted for stripping, and 2) the sliver is light after stripping. When you studied card clothing, you learned that very little stripping is needed on cards with metallic clothing, because there are no spaces in which dirt and lint can settle. The question naturally arose as to whether it might be possible to use flexible cylinder

clothing, but prevent it from becoming clogged up. In other words, could an attachment to eliminate stripping be developed? Such an attachment was actually developed by Saco-Lowell, and many thousands are in use. It is known as the continuous stripper. In reality, it is a device to eliminate stripping, but it was introduced under the name "continuous stripper," and we will have to call it that. Remember, though, that it is not a stripper in the sense of a cleaning attachment for the clothing, but rather a device to reduce the need for frequent stripping.

When a card is stripped with a conventional stripper, there are several periods during each shift when the card is non-productive. Also, part of the sliver produced after stripping is light and has to be discarded as waste. The continuous card stripper reduces card stoppage and loss of production caused by stripping.

You normally need to strip the doffer only about once each shift with a stripping roll or vacuum stripper, and the cylinder only about once every five shifts, or during a 40-hr period. The exact time depends on the stock you run and the quality standards to be met. It is not always necessary to stop the card while the doffer is being stripped, but it is better to do so. Stopping the card prevents the stripping roll from throwing waste matter into the card sliver.

Essentially, the continuous stripper consists of a set of needles projecting from a rotor. The rotor is set so that the needles extend into the cylinder wire. As the roll revolves, the needles brush against the back of the wire. By continually raising the fibers that become embedded in the cylinder, normal carding action is maintained, and the necessity for stripping is lessened.

#### **Continuous Stripper**

64. The continuous-stripping unit is mounted at the feed end of the card, as shown in Fig. 22. Brackets are attached

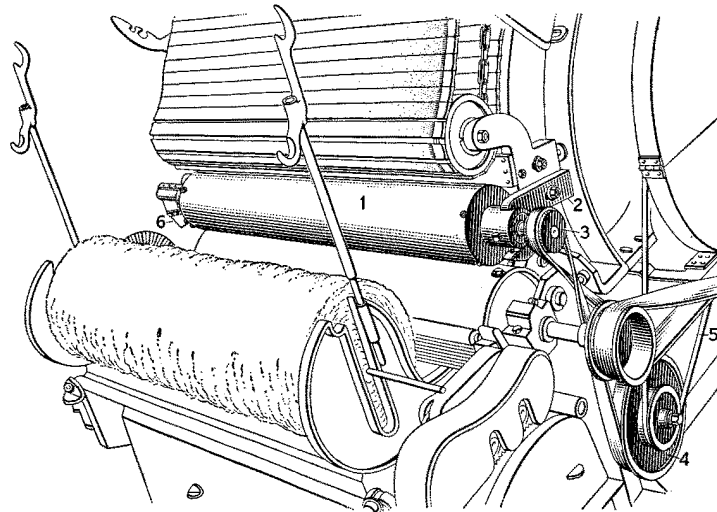

- |                              |                         |
|------------------------------|-------------------------|
| 1. continuous-stripping unit | 4. double pulley        |
| 2. bracket                   | 5. band to main pulley  |
| 3. rotor pulley              | 6. traversing mechanism |

FIG. 22. CONTINUOUS STRIPPER

to each arch of the card to hold the unit, which is enclosed in a steel casing. Power to drive the rotor is obtained from a double pulley, which in turn is driven from the main driving pulley. The drive is so arranged that the surface speed of the stripper is greater than that of the cylinder.

The rotor, shown in the section in Fig. 23 (*a*), is built around a  $1\frac{1}{2}$ -in. square steel shaft. The shaft has cylindrical ends which turn in roller bearings. Two lines of needle bars are attached to the square steel shaft. A side view of such a bar is given in view (*b*). The needle bars are mounted on wooden blocks which extend the length of the steel shaft. Bolts pass through the blocks, holding them to the shaft. The long, thin, flexible needles are mounted in groups of four. A group of three needle bars is bolted to each side of the shaft in such a manner as to stagger the needles; that is, the needle bars are so placed on the shaft that the needles on one side of



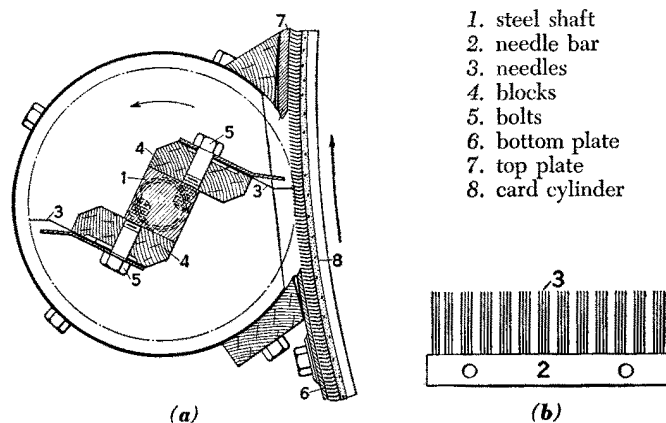

FIG. 23. ROTOR AND NEEDLE BAR

the shaft are not in line with, but come between, those on the other side.

A traversing mechanism, shown in Fig. 22, consisting of a worm and gear, is used to give the rotor a sidewise motion of about  $\frac{1}{4}$  in. The traverse varies the point of contact between the needles and the cylinder wire so the needles will pass between all of the wires.

**65.** Several changes must be made on a cotton card before a continuous stripper may be attached. The chain must be shortened by about six flats to make room for the stripping unit at the back of the card above the lickerin. A new back knife plate, made in two sections, is required. The bottom plate, Fig. 23, is bolted in place above the lickerin housing; keep a clearance of about 0.058 in. between the cylinder wire and the plate. A narrow top knife plate is bolted in place under the flats. Keep a clearance of about 0.058 in. between the lower edge of the plate and the cylinder wire, and a clearance of about 0.034 in. between the top of the plate and the cylinder wire. The stripper casing is bolted in place between the two plates in such a manner that the needles are in contact with the card wire for a distance of about  $1\frac{1}{4}$  in. This setting

should prevent the needles from extending too great a distance into the card wire and injuring the foundation of the card clothing.

You should be very careful in installing the stripper. It must always rotate in a direction opposite to that of the card cylinder and at a greater surface speed. The needle points must work against the back of the cylinder wire. With a cylinder speed of 165 rpm, the stripper should make about 1,720 rpm. Make the settings accurately. Keep the needles in good repair. The continuous stripper can be a great asset to the card, but only if it is properly taken care of.

While the continuous stripper works well on short and medium cotton, it is not recommended for extremely fine, long cotton. Nor is the continuous stripper suitable for use with synthetic staple. Except for work on these fibers, most mills that used the continuous stripper reported a reduction in carding cost, slightly less waste, and more uniform sliver.

#### Grinding the Card

66. When you studied card clothing, you learned about the need for grinding, and about the grinding rolls used. Review this material if you don't remember it. Now let's consider the details of grinding revolving-flat cards. Normally, the cards are ground in turn, unless some accident makes it necessary to regrind a card before the others are ground. Either way, you must get the card ready for grinding.

Disconnect the feed rolls by means of the switch lever, Fig. 24, which disconnects the side shaft of the card. Turn the feed roll backward by turning the plate bevel gear in the opposite direction from that in which it usually revolves. This rolls up the sheet and takes the fringe of cotton away from the lickering. Let the stock in the card run through. Strip the cylinder and doffer clean. Make sure that no fibers remain on the part stripped. Start the card, and let the flats run until they are bare of all strippings. This takes from 25 to 40 min.

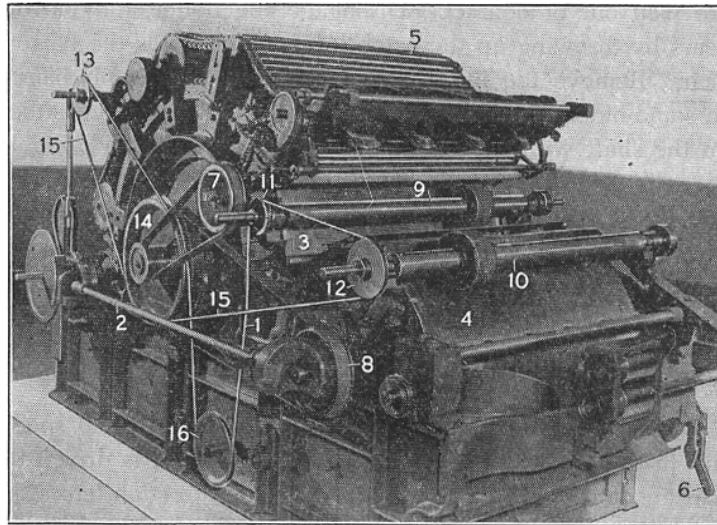

- |                           |                                    |
|---------------------------|------------------------------------|
| 1. switch lever           | 9. traverse grinder on cylinder    |
| 2. side lever             | 10. traverse grinder on doffer     |
| 3. cylinder               | 11. drive pulley, cylinder grinder |
| 4. doffer                 | 12. drive pulley, doffer grinder   |
| 5. flats                  | 13. drive pulley, flats grinder    |
| 6. catch lever            | 14. large pulley on cylinder shaft |
| 7. top pulley             | 15. long band to drive grinders    |
| 8. special belt to doffer | 16. tension pulley for long band   |

FIG. 24. CARD BELTED FOR GRINDING

Then stop the card again. Remove the fly from under the card and from between the sides of the cylinder and doffer, and from the framework where it collects. This waste is removed by means of a long, thin hook, usually made from a bale tie. Fly also collects around the shaft that connects the sprocket gears that drive the flats. Before grinding, be sure to remove all loose fly from around and under the card. If any fly remains, there is great danger of fire if the grinding roll strikes sparks.

67. Check and make certain that the switch gear and the side shaft, which were thrown out of gear before stripping,

are well out of contact. Disengage the doffer and barrow gears by throwing up the catch lever which holds the barrow gear. Remove the lickerin belt, flat belt, and comb bands. In some older-type cards, it is necessary to remove the pulley on the shaft with the worm that drives the flats, in order to accommodate the bands that are placed on the card for grinding. However, with most cards, you now reserve the belt that drives the top pulley for the flats. Later, when the direction of rotation of the cylinder is changed for grinding, the flats will move in the same direction and at the same speed as when carding. Look at Fig. 24, which shows a card that is belted for grinding.

During grinding, the cylinder is driven at the usual speed, but in the opposite direction to that in which it is driven for carding purposes. In order to reverse the direction, cross the driving belt, if it was previously open; but if the belt for driving the cylinder when carding was crossed, have the belt open when grinding. If you cross the belt for grinding, it will be somewhat tight. To avoid this, some card grinders use an extra belt of the right length, which they carry from card to card as grinding proceeds.

The doffer when being ground is driven in the same direction as it is for carding purposes, but at a higher speed. To do this, you use a special belt, driven from a pulley on the cylinder shaft. You had better use the setscrews to back off the doffer, that is, to move it further away from the cylinder. At the high grinding speeds, any contact between them would ruin the card clothing.

After you are sure that everything is clear of the cylinder and doffer and that the belts for driving them are properly adjusted, start the card. Brush the cylinder and doffer with a brush about 2 ft long and 3 in. wide. Hold the brush in contact with the cylinder and doffer wire, and move it from one side of the card to the other, thus removing all dust from the wire. Then let the card run a few minutes to remove the

dust that lodged in the flats when you were brushing the cylinder and doffer.

Stop the card, and remove the covers and bonnets. Put the traverse grinder for the cylinder in its stands. Then place the grinder for the doffer in position in its stands. Make sure the drive pulleys are on the proper side, that is, on the side opposite the main driving pulley of the card. The card cylinder shaft on the side opposite the main driving pulley carries a large pulley with two grooves to accommodate the driving bands for the grinders. Short bands are used if you grind the cylinder and the doffer only. But one long band is used if you have a third grinder that is also grinding the flats. Note in Fig. 24 how this long band is put on, and how it is held tight by a tension pulley at the bottom of the card frame.

When all the belting is in order and the grinders are set, you can go ahead with grinding, as you have learned in connection with card clothing. Correct grinding requires training right on the job, so you get "the feel" of it, before you can do it properly. It is best to work with an experienced card grinder for some time before you do it by yourself.

**68.** The grinding of the flats is a particularly difficult job. As you know, the flats are arranged in an endless chain, and they slide for a portion of their movement on a smooth, circular arc, while at another portion of their circuit they are carried over rolls on which they are suspended. This prevents their being driven past the grinding roll at the same speed as that at which they pass the card wire on the cylinder or doffer. It is possible—but it is not usually recommended—to grind the flats while the card is in operation. This is sometimes done, for instance, when metallic clothing is used on the cylinder and doffer. It saves a loss of time and production. In general, though, the flats can be ground at the same time the cylinder and the doffer are ground.

The grinding roll works on only one flat at a time, and therefore the flats must move very slowly.

Their slow movement causes considerable time to elapse before all the flats can be brought under the action of the grinding roll. To avoid this time loss, the dead roll is often used for grinding the flats, and is placed in brackets on each side of the card. These brackets are so adjusted that the roll, when resting in them, will lightly touch the wire of the flats as they pass from the front to the back of the card. That is, it grinds the flats while they are suspended by the bracket over which they move. An arrangement is used to firmly support the flat while it is being ground, and at the same time to hold it in such a position with relation to the grinding roll that the heel of the flat will not be ground off. When the flats are at work, the heel is closed to the card wire on the cylinder than the toe is. This relative position must be preserved with regard to the grinding roll, or the wire at the heel will be ground off before the wire at the toe is touched by the grinding roll.

69. Different attachments are used to grind the flats properly. We'll look at one of them, so that you will understand the principles. This attachment is illustrated in Fig. 25; sketch (a) shows the grinding apparatus in position, while sketch (b) is a perspective view of some of the essential parts. The brackets that support the different parts are attached to the side of the card, one bracket on each side. Resting against the inclined surface of the bracket is a casting that carries the bearings for the grinding roll. Attached to this casting is a finger that locks the grinding-roll shaft in position. The casting is secured to the guide piece by setscrews. It can be adjusted by loosening the retaining nut and turning the set nut. Using these adjustments, you can move the grinding roll nearer to, or farther from, the teeth of the flats. A pin that is carried by the guide piece may be set in either of the slots cast in the bracket, sketch (a). At its lower part, the guide piece carries the most essential part of the assembly. This is called the former, and it is so shaped that, if it is pressed against the

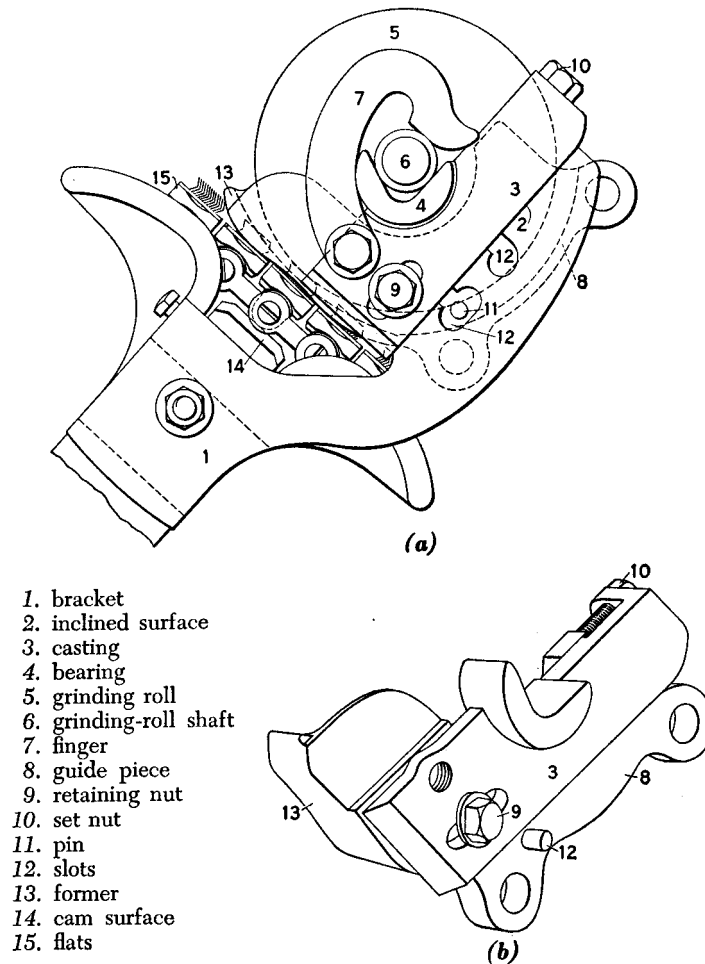

FIG. 25. CRADLE FOR GRINDING FLATS

end of the flat, the wire surface of the flat will be ground evenly across its width. These parts are, of course, duplicated on the other side of the card. Rods are held in the holes at each lower corner of the guide piece. The rods extend across the card and serve to connect the two sides. The whole mechanism is called a cradle.

Now let's see how it works. When the cradle is in position for grinding, the pin projects through the slot, as shown in sketch (a). Let's make it clear that, during grinding, the guide piece is not supported by the bracket. The weight bears on the ends of the flats, which are supported during this time by a cam surface attached to the bracket. As each flat moves from the front to the back of the card, it comes between the cam surface and the former, against which it will be rigidly held. The former is shaped in such a manner that it will bring the flat to its correct position in relation to the grinding roll. It is held in this position until it has passed entirely from under the action of the grinding roll. When the grinding arrangement is not in use, it may be raised and the pin inserted in the other slot, thus bringing all the parts out of contact with the flats.

#### Trouble Shooting for Revolving-Flat Cards

70. You should keep every card clean and in good repair. Follow carefully the manufacturer's instructions for lubrication. Set the card according to your check list. Grind it, or reclothe it, as needed. Watch temperature and humidity in the card room. If you do these things, you'll seldom have trouble.

To help you, we'll give you a check list for trouble shooting. It is based on recommendations by Saco-Lowell, but can easily be adapted to other cards. The locations of the points to check are given in Fig. 26, printed on an insert.

1. Look at the lap. It should be neither too tight nor too slack. Adjust the tension draft if necessary.
2. Slide your hand over the feed plate. It should be clean and perfectly smooth. If it is rough, smooth it with fine emery, and polish it with black lead.
3. Test the waste removed by mote knives and screens. Make sure you don't lose good fibers.
4. Worn bearings on the feed roll may cause neps and irregular sliver. Replace them if there is more than  $\frac{1}{32}$  in. of play.



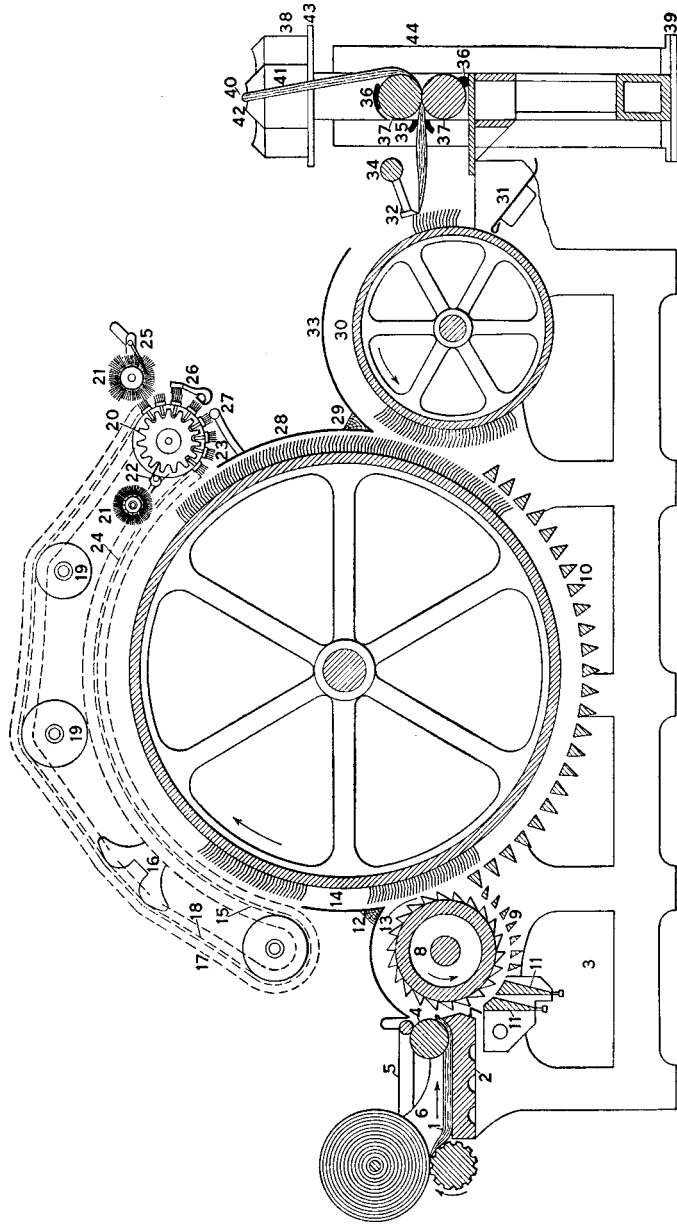

6202-73932

FIG. 26. CHECK POINTS FOR REVOLVING-FLAT CARD

5. The feed roll is pressed down by weights on hooks. If the hooks are bent or the weights don't hang free, the lickerin may pluck. This causes neps or thick places in the sliver.
6. On a 40-in. card, the selvage guides should be set so that the lap on the feed roll is a little over  $39\frac{1}{4}$  in. wide. On a 45-in. card, the laps should be a little wider than  $44\frac{1}{4}$  in. Check the selvage guides if the card web has ragged edges.
7. Run your hand over the nose of the feed plate. If it is rough, polish it with fine emery, and finish with whiting. Remember to change to a feed plate with a longer nose when you change to long-staple synthetics.
8. Check the lickerin carefully. The roll should be perfectly balanced, without high or low places. The wire must be sharp and clean. Make sure you are using the correct wire for the stock you are running.

The lickerin is the most important part of the card as far as cleaning is concerned. Worn, unbalanced, or misshaped lickerins, or those with dull or damaged wire teeth, will injure the stock. At each grinding, check the lickerin with special care. If you notice grease spots, rings of cotton, or impurities embedded in the teeth of the wire, look for the cause of these defects and remove it. When the wire teeth are dull, bent, burred, worn, or broken, such teeth will tear off the end of the lap in lumps. Increased waste, neps, high end-breakage in spinning—all of these are often the result of the false economy of using lickerins in poor condition instead of replacing them.

9. Dust, oil, cotton, wax, tar, and lint may stock to the lickerin screen. Clean the screen and polish it with black lead when it gets dirty.
10. The cylinder screen gets just about as dirty as the lickerin screen, but it is much harder to reach. If it has become so dirty that you can't just wipe it off, use a rag dipped in a 50-50 mixture of household ammonia and water. Then smooth it with whiting and polish it with black lead.
11. Run your hand over the edge of the mote knives. Remove nicks, or rough places where fibers may cling.
12. Make sure that no stray air currents enter between the lickerin cover and the back plate. The seal should be tight.

13. If the web is cloudy or full of holes, check the lickering setting.
14. If flats and cylinder load up, check the back plate setting. Make sure it doesn't touch the flat clothing.
15. The bend is most likely to wear at the point where the flats first touch it. Replace bends if a hollow is worn into them.
16. If the flats don't seem to act right after grinding, check the grinding cradle. The stands must be exactly parallel on both sides, or the flats are ground lopsided.
17. Check frequently for felted flats, blistered or damaged clothing, and other faults on the flats. It is quicker and cheaper to fix a damaged flat than to rebuild the card after a fire.
18. Check the flat screws after grinding. Tighten any that are loose.
19. The oiler doesn't like to reach up—a drop of oil may run down his arm. To be sure that he has done his work, check the flat-chain idler guide pulleys. If they have been neglected, clean choked bearings and oil them.
20. Check the worm drive assembly for the flats after grinding. It needs cleaning and oiling from time to time. If the chain that drives the spiral brush has stretched too much, take out a link.
21. Brushes that are dirty, oily, or worn can't keep your cards clean. Keep the brushes clean. Replace them when worn.
22. A piece of leather, called a scavenger, keeps the disks clean. Replace it when it is worn.
23. Check the slack of the chain. The flats may touch the back plate when the chain has stretched too much. Check the back plate settings.
24. Take a look at the flexible bends. They sometimes become scarred or cracked, or lose their even shape. Lubricate the bends lightly with graphite and oil.
25. Check the hackle comb to be sure that it keeps the spiral brush stripped.
26. The stripping comb for the flats wears out in time. Make sure it isn't bent or damaged. Watch for teeth that are worn round and dull.
27. The scavenger roll, or Thompson roll, has a rough cloth surface to catch and roll up the flat strips. Re-cover the roll

- when it becomes smooth. Check the roll shaft for wear, and replace it if it is worn. A spring holds the roll in working position. Replace this spring when it has lost its tension.
28. Check the stripping door in the front plate. If it has been banged around and bent, air currents will get in.
  29. Make sure that no stray air currents enter between the doffer cover and the back plate. The seal should be tight.
  30. Check the inside of the doffer cover. Smooth rough spots and polish with whiting.
  31. The edge of the dust pan should be  $\frac{1}{4}$  in. from the doffer surface. Keep it clean, or lint will be blown into the web.
  32. The working edge of the doffer comb must be straight. Replace it if you find worn, bent, dull, or hooked teeth.
  33. Brush off the doffer cover. If you find oil drippings, investigate to find out where they come from.
  34. Check the comb box carefully. Normally, the comb eccentric shaft should run about 125 times as fast as the doffer shaft. It will not work if the drive bands are loose. Check for worn parts. Oil if necessary.
  35. The trumpet plate must be clean and smooth and free from lint, so it can guide the web properly.
  36. Clean the calender roll clearers. Re-cover them before the cloth becomes so worn that the metal underneath touches the calender rolls.
  37. Check the calender rolls. The surfaces must be clean and smooth. Don't permit fly to collect in the gearing. Keep the bearings cleaned and oiled.
  38. While grinding, clean and oil the coiler gearing from one end to the other.
  39. Clean and oil the gearing and moving parts that give motion to the can table.
  40. Check the coiler trumpet with a trumpet gauge. Make sure the trumpet is clean and smooth. Be sure you are using the right size for the weight of sliver you are running.
  41. Check the lug on the trumpet tongue. If it is worn, the trumpet drops down a little. This causes lumpy sliver.
  42. The coiler calender rolls are small and run rapidly. Make sure their bearings are clean and oiled.
  43. Clean the tube gear and the plate that carries it. Oil the gear lightly. Rough spots inside the tube will cause chokes.

44. The coiler assembly must be in alignment, vertically and horizontally. If the cans are not holding as much sliver as they should, check the gearing and setting.

#### Trouble Shooting for Roller-Top Cards

71. When you compare the check list for the roller-top card with that for the revolving-flat card, you'll find that the cards have much in common. However, instead of referring you to the former list, we'll repeat these items, so that you have a complete list for each type of card. The location of the check points is given in Fig. 27, which you can refer to as you go through the list.

1. If there is too much, or too little, tension on the lap, the sliver weight may fluctuate.
2. You can't expect smooth delivery if the feed plate is rough. Remove rough places with fine emery. Clean the plate and polish it with black lead.
3. Check the waste extracted by mote knives and screens at least once every 40 hr. Set, clean, or repair these parts if good fibers are being wasted.
4. If the play in the feed-roll bearing exceeds  $\frac{1}{32}$  in., you may get neps and irregular slivers. Repair it before this happens.
5. To prevent neps, plucking, and thick places in the sliver, the feed rolls must be pressed down to exercise control. Make sure that the weight hooks are not damaged and that the weights hang freely.
6. If the web has ragged edges, the chances are that the selvage guides are not set right. Measure the width of the lap on the feed roll. It should be  $\frac{1}{2}$  to  $\frac{3}{4}$  in. narrower than the width of the card cylinder.
7. The special long nose of the feed plate for synthetics must be perfectly smooth. Remove rough spots with fine emery, then clean it, finish with whiting, and polish with black lead.
8. For good work, the lickerin must be perfectly balanced, and the wire must be clean and sharp. Increased waste, broken ends in roving and yarn, excessive neps—all these defects can often be traced to a bad lickerin. Check, clean, and repair the lickerin when necessary—at the least, every time the card is ground. Be sure the lickerin cover is clean inside, and that it is tightly in place while the card is working.

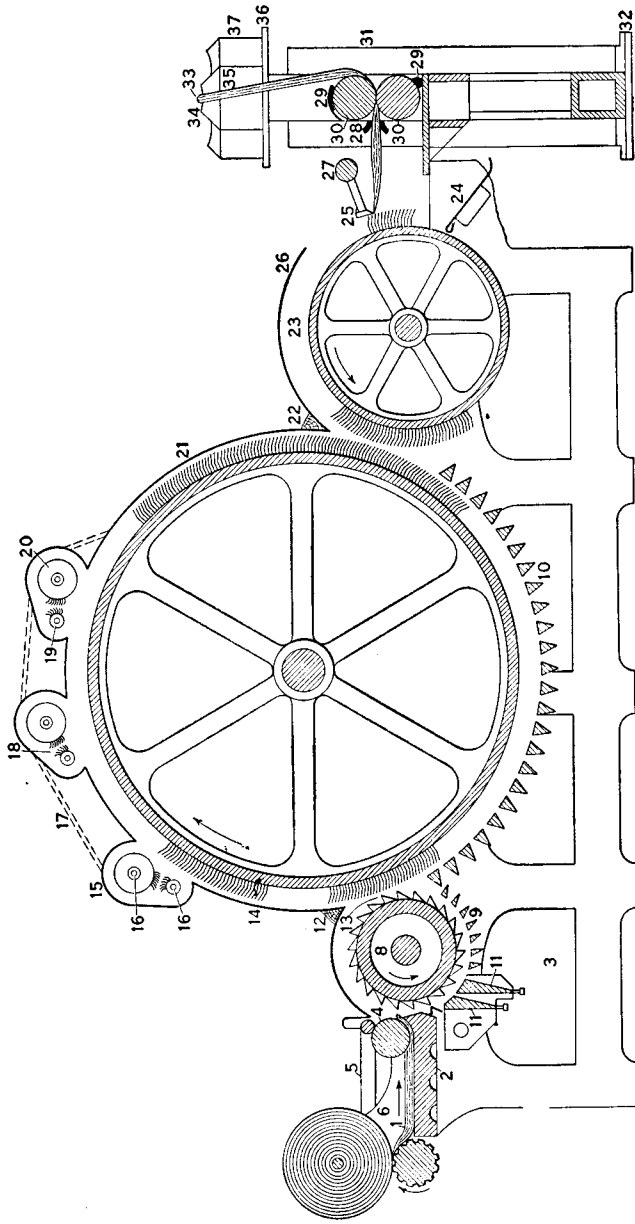

6202-73932

FIG. 27. CHECK POINTS FOR ROLLER-TOP CARD

9. The lickerin screen must be cleaned and polished with black lead whenever it gets dirty.
10. The cylinder screen needs care, just like the lickerin screen. Since the cylinder screen is harder to get at, it is often neglected. Check it at least once a year.
11. Clean, smooth, polish, and set the mote knives. Though there are no "motes" in synthetic stock, the knives will help to remove many neps and broken fibers.
12. Check the seal between lickerin cover and back plate, so no air can get in.
13. If the web is cloudy and full of holes, check the lickerin-cylinder setting. Stop the card and look at the lower part of the lickerin, that is, the part that has passed the cylinder. If it is full of fibers, check the setting—it may be too loose.
14. Cylinder and workers sometimes become loaded, especially in carding synthetics. Faulty setting of the back plate is often to blame.
15. The covers on the rollers must fit tightly. If air currents get in, they will disturb the carding action. Covers that are dented through careless handling may touch the roller clothing and cause fires.
16. Lint may get into roller bearings, where it causes friction. Worn bearings will result, and will prevent accurate settings.
17. The chain (or on other models, the V belt) which drives the workers must be just right. If it is too tight it will strain and wear the bearings. If it is too loose it will sag and skip. Keep it free from lint and dirt.
18. Even if the cylinder has conventional flexible clothing, the workers and strippers usually have metallic clothing. Hooked or dull wire will not give good carding action. Metallic clothing requires just about the same care as the lickerin.
19. Check rotation of the strippers. They should normally make 295 rpm in a clockwise direction. Set them with a No. 17 gauge to the worker and with a No. 10 gauge to the cylinder.
20. If you have trouble with the workers, experiment with rotation. Normally they should run clockwise at about 8 rpm. Sometimes, especially on fine stock, they will work better if you run them in the opposite direction. Set them to the cylinder with No. 10 gauge.
21. Check the stripping door in the back plate. It should be clean and straight, and should fit tightly.

22. The seal between doffer cover and front plate must fit tightly, so no air can get in.
23. Clean the inside of the doffer cover. Polish it with whiting if necessary.
24. Keep the dust pan clean, or lint may be blown into the sliver. The front edge of the pan should be  $\frac{1}{4}$  in. away from the doffer clothing.
25. A doffer comb with bent, worn, or hooked teeth cannot prepare a smooth web for the doffer to take off the cylinder.
26. Clean the doffer cover. If you see oil drippings, find out where they come from.
27. Check the comb box mechanism for dirt and wear. The normal speed of the cam is 125 times the speed of the doffer.
28. Polish the trumpet plate. The sliver cannot be smooth if it gets caught on rough edges of the trumpet plate.
29. Keep the clearers clean. Re-cover them before the metal comes through and damages the calender rolls.
30. The calender rolls must be polished. Their gears and shafts should run in a film of oil, not in a layer of lint.
31. Clean, oil, and check the whole coiler gearing at each grinding at least.
32. Clean the plate gear and its assembly in the base of the coiler.
33. Check the trumpet hole with the trumpet gauge. Make sure that the opening is right for the sliver you are running.
34. Look at the position of the trumpet tongue. It is held in position by a lug. Replace the lug if it is worn and allows the trumpet to hang too low.
35. The small coiler calender rolls run rapidly. They should run in well-oiled, not lint-packed, bearings.
36. Clean the tube gear and its plate at least once every 40 hr. Polish the inside of the tube, or you'll get chokes.
37. Check the gearing and alignment of the coiler assembly. Otherwise you'll have trouble with filling the cans properly, and with lifting the sliver out later on.

### *Quality Control and Research*

#### **Empirical Methods**

72. The dictionary defines empirical as "depending on experience or observation alone, without using science or theory."



This is the way the whole card room was run about half a century ago, and even today experience and observation are still important. Let's see how an experienced overseer makes use of the empirical method to check the quality of the carding operation.

First, he takes a piece of the web and holds it against the light, so that neps and impurities show clearly. If, in the opinion of the overseer, the web is below standard, he'll inspect the card to see what is wrong. Second, the overseer takes a handful of waste from underneath the card. If, in his opinion, the waste contains too much good fiber, he checks the card. Third, he looks at the sliver from time to time, to see if it looks even. If it does not, he experiments with speeds and settings until the condition improves.

By such simple methods, quick spot checks can be made on the card production. The empirical method requires an experienced overseer, but no expensive instruments and no special test personnel are needed. The only trouble is that the overseer is human. If he is sick or on vacation, trouble brews in the card room, unless there is a first-rate assistant overseer. If the overseer is harassed with personnel problems, as he is likely to be these days, his judgment may not be perfect. For these reasons, and also for more accurate test results, scientific methods were developed to supplement the judgment of the overseer. Let's clearly understand, however, that the scientific quality-control methods should not be regarded as a substitute for the experienced card-room overseer. They simply give him better information to work with, just as a microscope makes it possible to see things that are too small to be visible to the naked eye.

#### Scientific Methods

73. We have noted the three factors checked by the card-room overseer: 1) the waste made by the card; 2) the evenness of the sliver; 3) the neps contained in the web. Scientific

tests have been developed to check these factors. The tests are used to reduce the amount of waste to the necessary minimum, to assure reasonably even sliver in further processing, and to avoid defective yarn due to neps. Furthermore, the tests make it possible to evaluate different models of cards in an objective manner. You'll be able to select the best card for your purposes without being influenced by the claims of the card builder or by the fact that you like or dislike his agent. Finally, when you read about new theories regarding card speed and card settings, you can test to find out whether or not they will work with the cards you use and with the fibers you are carding.

The management in most textile mills today is aware of the value of scientific control methods. The only question is how far to go in adopting them. A research and quality-control department, if set up as an independent unit, has an unfortunate tendency to grow and expand far beyond the point where it assures maximum efficiency. Without good coordination, much of the department's efforts may be wasted. The quality-control personnel should have thorough, practical mill training. On the other hand, the card room overseers and second hands should receive some training in scientific test methods. In this way, close cooperation can be achieved, and the test results can be promptly put to practical use. Now let's look in detail at some scientific test methods used in carding.

#### Types of Card Waste

74. Waste tests consist of the careful weighing of all waste matter and all sliver produced by a card, as well as the weighing of the amount of stock fed to the card. They should be conducted at periodic intervals. A waste test offers a check on the loss of stock in carding. It also gives an indication of the mechanical condition of the card. Last, but not least, records are obtained which are helpful for computing costs.

Let's examine the three main types of waste produced by a card.

1) *Motes* are removed from the stock by the mote knives and the lickerin screen. They are therefore found under these parts. In cotton carding, motes usually consist of heavy leaves, sticks, dirt, and practically all heavy foreign matter not removed in the opening and cleaning processes. This type of waste matter has practically no market value, because it generally consists of trash and contains very little cotton fiber.

In carding synthetics, the mote knives remove fly and small bunches of matter fiber. Fly consists of short fibers and light dust that have dropped or have been thrown from the main cylinder and the doffer. Some of this waste comes from under the cylinder screen. Fly is generally included with the mote waste in tests, because only a small amount is usually found. Fly is a term also applied to the short pieces of lint that defile the air and settle on various parts of the machinery and on the floor of the card room.

All material found around a card during a waste test is recorded as waste, called floor sweepings. Motes, fly, and sweepings amount to perhaps 1 to 3% of the stock fed to the card.

2) Another type of waste consists of *cylinder and doffer strips*. These are obtained by stripping the cylinder and doffer of embedded fibers. Usually these strips consist of short matted fibers, with some dust and dirt. The amount of waste to expect from this source is about 0.5 to 1.5% of the stock. The exact percentage varies, depending on the fibers used, the condition of the card clothing, and the frequency of the stripping operations. Fiber of this character generally has very little market value because of its shortness. Of course, if you use metallic card clothing, or a continuous card stripper, there will be hardly any cylinder strips.

3) There are also *flat strips*. These consist of the fibers carded from the stock by the revolving flats. Generally, flat

CARD WASTE TEST

\_\_\_\_\_ COMPANY

Lot No. \_\_\_\_\_ Test No. \_\_\_\_\_ Date \_\_\_\_\_ 19\_\_

Grade \_\_\_\_\_ Time Run \_\_\_\_\_

Staple \_\_\_\_\_

Waste Collected			
Waste	Pounds	Ounces	Per Cent
Cylinder and Doffer Strips			
Flat Strips			
Motes and Fly			
Sweepings			
Total Card Waste			
Wt. of Lap—Start _____		Wt. of Sliver _____	
Wt. of Lap—Finish _____		Wt. of Sliver Waste _____	
Total Fed _____		Card Waste _____	
		Total Delivered _____	
CHECK BALANCE			
Total Fed _____			
Invisible Gain _____			
Total Delivered _____			
Invisible Loss _____			
Total _____			
Per Cent Invisible Loss or Gain _____			
DATA			
Size of Lap _____			
Size of Sliver _____			
Main Cylinder R.P.M. _____			
Lickerin R.P.M. _____			
Doffer R.P.M. _____			
Flats—Inches per Min. _____			
Draft Gear _____			
Barrow Gear _____			
		MOISTURE CHECK	
		Wt. at Start _____	
		Wt. at Finish _____	
		Loss or Gain _____	
		Per Cent _____	
Remarks: _____			
Test made by _____		Approved by _____	

strips amount to about 2.5 to 3.5% of the stock, depending on the grade of stock run, the card settings, and the condition of the card clothing and flats. Flat strips have a fair market value. However, some mills that work on low and medium grades return the flat strips to the picker, to be used with the new stock.

The objectives of carding, as far as waste is concerned, are simple. Undesirable dirt, fly, and neps should be removed, as far as possible. As little good-fiber stock as possible should be removed.

#### Records for Waste Tests

75. In order to have a record for evaluation, the results of the waste tests must be recorded. A record sheet similar to the Card Waste Test shown is used. Divisions are made on this record sheet for tabulating the data. Under the heading *Waste Collected*, space is provided for recording, in pounds, ounces, and per cent, the amount of waste stripped from the cylinder and the doffer, the flat strips, the motes and fly, and the floor sweepings. Space is also provided for the original weight of the lap and for the weight of the lap remaining after the test. The final lap weight should include the lap rod, because it is weighed with the lap before starting. If the entire lap is consumed during the test, the weight of the lap rod will constitute this reading. In short, you must record the amount of stock fed during the test.

In another column the weight of the sliver produced is recorded. This is generally found by subtracting the weight of the sliver can from the gross weight of the sliver. The sliver waste, that is, the sliver discarded at the beginning of the test as being too light, is listed, and also the total card waste. The invisible gain or loss (a calculated value) is computed, both in weight and in per cent.

The term *invisible gain* signifies an increase in the weight of the fiber processed. In other words, if the card produces

a combined weight of sliver and waste which is greater than the weight of lap fed to it, there will be an invisible gain. The term *invisible loss* is the opposite of invisible gain. That is, more stock is fed into the card than can be accounted for at delivery. A moisture test is usually run simultaneously with the waste test for checking the invisible losses or gains. Space is left for recording the weight of a sliver used for the moisture test at its start and finish. Additional space on the sheet is used for listing such information as cylinder speeds, draft gear sizes, and the like. Also, as you have learned previously, it is a good idea to fill out a check list of the settings, so you can refer to it when you evaluate the waste test.

#### Conducting the Waste Test

76. Clean the card thoroughly before the waste test run is begun. Strip the card cylinder and the doffer. Let the flats make one complete revolution, to be certain all waste matter in them has been removed. While the flats are being stripped, remove all waste from under the card. Brush the card to remove all lint and fly that may have settled on it. Sweep the floor around the card. Throw out all waste thus far collected; it is not pertinent to the waste test.

Weigh the lap. Place it in the card, and start the card. Record the lap weight under *Wt. of Lap—Start* on the test sheet. The card sliver produced should be running at its normal size after a few minutes of card operation. As soon as it is normal size, thread the sliver through the coiler head. Let the card operate for a standard time, or until the lap has about run out. Weigh the sliver in the can, and enter the weight under *Wt. of Sliver*. Weigh the undersize sliver which was first produced and which was not run through the coiler head. Record it on the test sheet under the heading *Wt. of Sliver Waste*, along with the web waste made after the sliver has been broken off at the completion of the test. Weigh the remaining lap section and enter this weight under *Wt. of Lap*

—*Finish*. Subtract this weight from the gross lap weight to find the total fed into the card, and enter the result under *Total Fed*.

Let the card run out. Strip the cylinder and doffer. Remove all card waste. Record its weight in the proper columns, the notes and fly being weighed together. After the flats have revolved once to insure stripping of all of them, weigh and record the flat strips. Brush the card and sweep the floor in the vicinity of it, to collect all fly and lint that has been thrown off by the card. Record the weight of the sweepings. Add these wastes and enter the total under *Card Waste*.

Enter under *Total Delivered*, the sum of the weight of all card waste, of sliver waste, and of card sliver produced. Theoretically the total weight fed and the total weight delivered should be exactly equal. However, there will often be a difference. It is possible that the stock has lost or gained a little moisture during testing. You can run a moisture check, to make sure that this was the cause of the invisible loss or gain. If the moisture check doesn't agree with the invisible loss or gain, better run another test—very carefully this time.

#### Moisture Check

77. You should study complete moisture tests in connection with textile testing. All we need at this time is a simple check on the waste test. The moisture check is easy to make and doesn't require expensive equipment. Take a sample of the lap being processed—for example, one weighing 500 grains. Place it close to the card and on which the test is being made. Weigh the sample after the waste test to determine whether the sample has gained or lost weight. An increase in sample weight indicates that it has picked up moisture from the air. The same per cent of increase will also take place in the fibers being tested in the card. Therefore, the total weight delivered will exceed that of the total fed. This weight increase does not actually change the volume or the amount of stock processed, and because of this it is called an invisible gain.

A decrease in the weight of the sample during the moisture test will indicate that the air has absorbed some of the moisture that was in the stock. In this case the check balance of the test sheet should show an invisible loss.

The per cent listed under *Check Balance* and the per cent listed under *Moisture Check* will show you whether the invisible gain or loss is due to moisture or to errors you made in the test. Generally, the gain or loss in the stock expressed in per cent and the gain or loss in the moisture check expressed in per cent should be approximately equal. A large variation in the percentages shows that errors have been made in the waste test.

In calculating results, remember that there are 7,000 grains, or 16 oz, in 1 lb. Also remember that the percentages are always expressed in hundredths of a given total. In the waste test this total is the total weight of the lap fed. In the moisture check the total is the weight of the sample, which was 500 grains in our example. The accuracy obtainable on a 10-in. slide rule, as explained in *Mechanical Calculations*, is usually sufficient for a waste test.

#### Waste Tests to Compare Lots

78. If you run cotton, it is important to know how much of a given lot you'll lose as card waste. For example, you have two different samples of cotton, both of the same grade but from different sections of the country. Let's assume that practically all the characteristics of the cotton are alike, but that the mill management would like to know which cotton would be the more economical to buy. A card waste test could be run, and the sample showing the lower percentage of waste would normally be the better grade to buy.

Comparative waste tests are often run on various grades of cotton to determine which grade is the most economical to process. Even though the initial cost of a lower grade of cotton may be less than that of a superior grade, the final cost



of the processed cotton for the better grade may be less. This is partly shown by the waste test. Usually, a much greater amount of waste will be obtained from the low-grade cotton, and therefore more frequent cleaning of the card will be necessary. The increased amount of waste and cleaning will increase the frequency of card grinding, and will result in an increase in production cost. When the final cost computations are made, in many cases it will be found that using a higher grade of cotton will be more economical. That is, in spite of the higher initial cost of the cotton, the final cost per pound processed may be less.

#### Waste Tests for Card Efficiency

79. Suppose you want to test a number of cards, to see if they are operating efficiently. In that case, all the cards in the test group must be processing the same type of stock and running at the same speed. Conduct the tests as much alike as possible. Then compare the results. If a few cards show excessive amounts of waste, these cards need attention.

An expert carder can often determine the mechanical condition of his card by inspecting the waste produced. For instance the carder may, by glancing at the waste, know if his card needs regrinding. The efficiency of a card can also be determined by inspecting the flat strips. The strips should have just a sufficient amount of long fiber in them to allow them to hang together. If a greater amount of long fiber is present, good fiber is being removed by the flats; if not enough long fiber is present to hold the strips together, insufficient fiber is being removed by the flats.

Another reason for performing waste tests is to compare different models of cards. Let's say the mill management is undecided as to which make of card to buy, and orders two test cards. Both cards will be set by the erectors from the card manufacturer, and you must run them with the same speed and on the same stock. The first waste test shows that

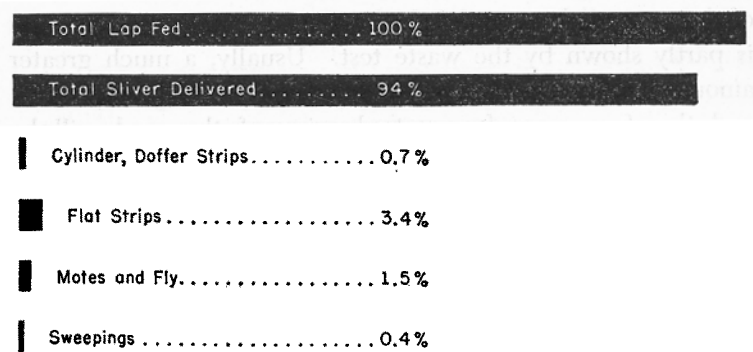

FIG. 28. WASTE PERCENTAGES

card A makes just a little more waste than card B. You continue to test every day for several weeks, while the cards are kept producing. After four weeks you find that now card A still makes about the same amount of waste as it did in the first test; but card B makes much more waste than either card made in the first test. Chances are then that card B does not hold the settings very well, or needs other attention. Of course, waste is only one factor in evaluating cards, but it should be considered.

#### Composition of Waste

80. Each different grade of cotton will result in a different type of waste. Also, a card with flexible clothing and without a continuous stripper will make more waste than a card with a continuous stripper or one with metallic clothing. So it is impossible to say exactly what you can expect in the way of waste.

Just to give you an idea though, let's look at the results of a waste test in graphic form. This test was conducted on a card producing  $4\frac{1}{2}$  lb per hr, carding stock of  $1\frac{3}{8}$  middling cotton. In Fig. 28 you will note that 6% waste was made, and you can see how this per cent was distributed for each type of waste. Now we'll find out what carding did to the fibers.

In the original lap the average fiber length was 1.1 in., but 25% of the fibers were under  $\frac{1}{16}$  in. In the sliver the average fiber length was 1.09 in., but there were only 22% of the fibers under  $\frac{1}{16}$  in. Thus, while a few long fibers were broken in carding, many undesirable short fibers were removed. As you saw in the illustration, more than half of the waste consisted of flat strips. In these the average fiber length was 0.95 in., with 40% of the fibers under  $\frac{1}{16}$  in. This waste obviously is still a fairly good material for processing into coarser yarns. The cylinder strips were a little poorer, and the doffer strips were still poorer. However, the dirtiest and poorest waste is found under the screens. The lickerin waste, for instance, had an average fiber length of 0.4 in., and 92% of the fibers were under  $\frac{1}{16}$  in. In general, then, as far as cleaning action is concerned, the screens and mote knives are the most important points of the card. It will be well for you to keep this in mind, because they are often neglected in card maintenance.

#### Uniformity Tests

81. The subject of waste is of great importance to you if you are responsible for the cards. But of equal importance, or even greater importance, is the uniformity of the sliver. After all, the stock is carded and put into sliver form only so that it can be drafted into roving and spun into yarn. Let's say, for instance, you are supposed to produce 50-grain sliver. Your cards are not set very well, and some cards produce 48-grain sliver, while others produce 52-grain sliver. Suppose these two groups of slivers are kept separated by some chance. Eventually, if you are spinning 25s yarn, you will wind up with 24s and 26s instead. Testing can help you two ways in this case: 1) the light slivers can be matched evenly with the heavy slivers during drawing; and 2) corrective action can be taken on the cards.

In the example just given, we assumed that the sliver from any one card was uniformly light or heavy. More often, sliver

from the same card may be nonuniform, or uneven. That is, thick and thin places alternate in the sliver. If you are lucky, this condition may be removed during drawing. If the thick places in one card sliver happen to be alongside the thin places of another sliver while both are being run through the drawing frame, they may cancel each other more or less. Years ago, when numerous drawing and roving processes were used, this was the generally adopted principle. With luck, skill, and persistence you would wind up by getting reasonably good yarn.

Today this hit-or-miss system is too costly. The number of processes has been reduced. With constant testing for evenness and with improved fiber control in modern machinery, we can have better yarn with less repetitive operations. We'll now explain some methods, from the simplest to the most complex, that are used for evenness testing.

#### Sliver Weight Tests

82. A check on the uniformity of the sliver can be maintained by weighing 1-yd lengths of the sliver at frequent intervals. To do this, cut 10 lengths of sliver, of 1 yd each. Weigh each individually. Calculate the average of the 10 weighings. The deviation—that is, the variation between each weighing and the average weight—can then be determined to give an indication of sliver evenness.

In this test you have found only the variation of each 1-yd length. But it is possible for variations to occur in lesser lengths, such as 1-in. lengths of sliver. For example, a 1-yd length of sliver may show great variations in 1-in. lengths, but these variations may cancel each other in a 1-yd length. That is, the sum of the variations above the average weight and the sum of the variations below the average weight may equal each other. In this case, the 1-yd weight would appear to have practically no variation, while actually, inch for inch, a tremendous variation would exist.

It would be impracticable to weigh smaller units of length than a yard. Not only would it take too much time, but errors are hard to avoid in small weighings. Yet the checking of small units of length in a sliver is of great importance for the production of uniform sliver. Therefore, mechanical and electronic instruments have been developed to test uniformity efficiently and constantly, and with a minimum loss of valuable sliver.

#### Saco-Lowell Sliver Tester

83. A sliver tester was developed by Saco-Lowell. This machine contains two rolls that slowly draw between them the card sliver to be tested. A weight acting through a set of levers compresses the sliver as it passes between the rolls. A pen carried on one of the lever arms records, on a traveling chart, the degree of compressibility in the sliver, and consequently the variation in sliver evenness. You'll notice that the sliver tester doesn't test the weight of the sliver, but tests its diameter under pressure. However, the weight and the compressibility are closely correlated, and the tests are valid for most practical purposes. The sliver tester can be easily adapted for tests on roving, but in this text we'll only study its value for testing card slivers.

In former times, when it was desired to determine which of two lots of cotton would make better sliver, it was necessary first to make the cotton into yarn. Then, by comparative breaking tests, the better cotton was determined. Today, it is only necessary to process the cotton through the card. Then, by comparing the charts of each sample of sliver as it is run through the sliver tester, the superior sliver can be ascertained. Generally, uniformity in sliver will be carried into the drafting and spinning processes. Uniformity in the spun yarn is usually an indication of yarn strength and quality.

Comparative card tests may be run and the sliver tester used to determine which card is producing the highest quality

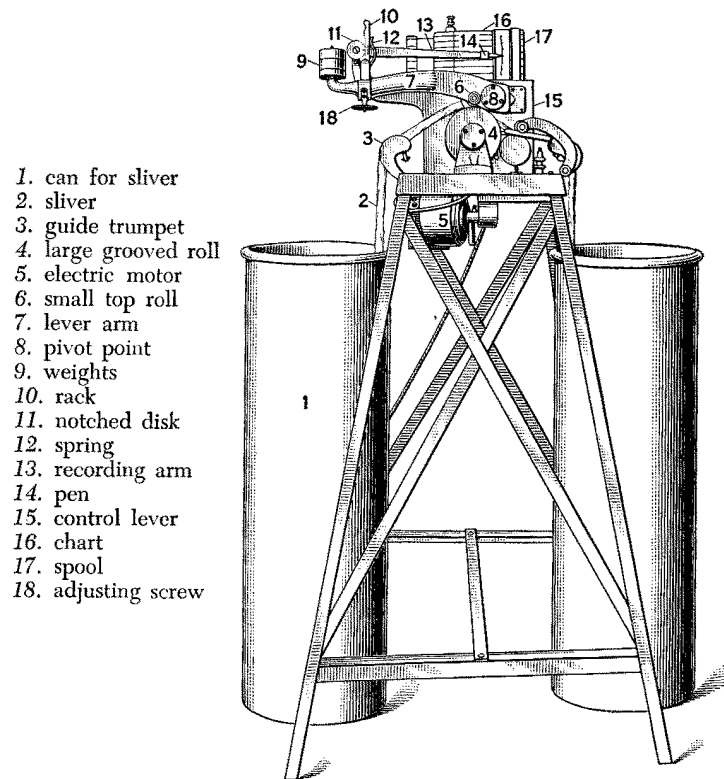

1. can for sliver
2. sliver
3. guide trumpet
4. large grooved roll
5. electric motor
6. small top roll
7. lever arm
8. pivot point
9. weights
10. rack
11. notched disk
12. spring
13. recording arm
14. pen
15. control lever
16. chart
17. spool
18. adjusting screw

FIG. 29. SACO-LOWELL SLIVER TESTER

of sliver. Those cards producing uneven sliver can then be adjusted to improve the quality of their product. Often it is found that the production of a card may be increased considerably without reducing the quality of the sliver produced.

In short, intelligent quality control, closely coordinated with the technical management of the cards, results in a better product and increased production.

#### How the Tester Works

84. The Saco-Lowell sliver tester is shown in Fig. 29. A can of card sliver is set in position, and the sliver to be tested

is threaded through a guide trumpet and put between the rolls. The large lower roll is driven by an electric motor, through a gear train. Two grooves of different widths but of the same depth are cut into the circumference of this roll. One groove is made wider than the other to accommodate slivers, while the smaller groove is used for roving tests. A small roll is located above the large roll. The small roll is constructed in such a manner that two V-shaped disks on its surface mesh with the grooves on the lower roll, so you will not need to change rolls every time you switch from testing sliver to testing roving. The small top roll is held in the lever arm by a pin. The lever arm is free to revolve about its pivot point. The sliver is drawn forward by the rolls and is compressed in the groove by means of weights acting through the lever arm and the small top roll.

A variation in cross section of the sliver as it is slowly drawn forward by the rolls will result in the raising or lowering of the small roll, and consequently of the lever arm. An upright rack is carried at one end of the lever, and by means of a spring this rack is held in mesh with a partially notched disk. A capillary pen is carried at the end of a recording arm which is attached to the disk. Motion imparted to the lever arm by the sliver will raise or lower the rack, which, in turn, moves the notched disk. The disk will cause the recording arm to raise or lower the pen.

The sliver tester is so constructed that any movement given to the small roll is multiplied 100 times at the pen. Therefore, for each 0.001 in. the top roll moves, the pen will move 0.1 in. The movement of the pen is recorded on a paper chart, which is drawn behind it at a uniform rate of speed. The resulting chart is a continuous line plot of the sliver variations recorded in thousandths of an inch. The mechanism for driving the chart is so arranged that by moving the control lever the speed at which the chart is wound on the spool may be varied. One speed records the variations of 1 in. of sliver over a distance of

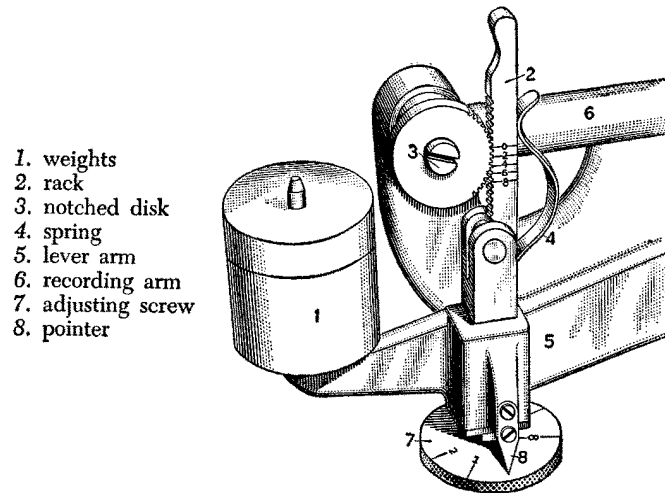

FIG. 30. DETAILS OF TESTER

1 in. on the chart, while the other speed records the variations in 1 yd of sliver over a distance of 3 in. An extension cord attached to the motor makes the tester a portable unit, and you can move it from one end of the mill to the other. Tests can be made under the same temperature and humidity conditions as those used in processing the sliver.

85. The weights of the sliver tester and the parts near it are shown in more detail in Fig. 30. Both of the weights shown are required on the weight arm, when sliver is tested, to provide the correct degree, but only one weight is required for roving.

To operate the tester, move the lever controlling the speed of the chart to its central, or neutral, position. This motion disengages the clutch and prevents the chart from being drawn forward by the take-up roll. The capillary pen is filled with a special ink used for such purposes and is adjusted to come in contact with the chart. Make a long twisted point on the sliver in order to thread it through the trumpet.



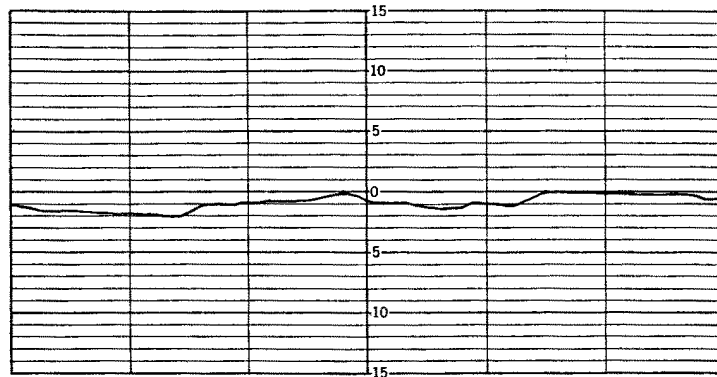

(a)

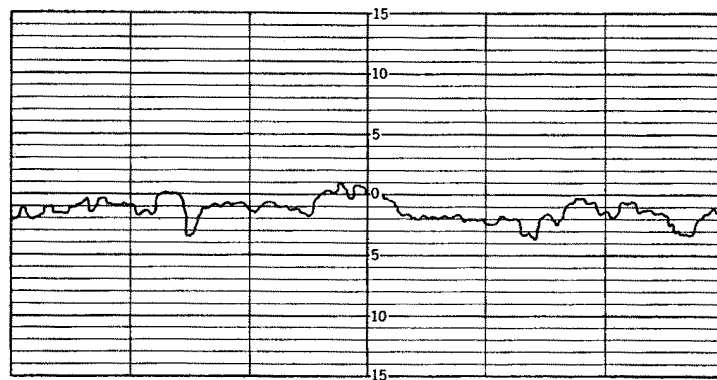

(b)

FIG. 31. SLIVER TEST CHARTS

Hold the rack to one side, thus disengaging the disk as you start the motor. The lower and top rolls revolve and draw the sliver forward. The lever arm and the rack will rise as the sliver passes between the rolls. Don't release the rack until the pen is at the center of the chart. This makes all calculations in connection with the charts simpler. Use the numbered adjusting screw to bring the pin to the approximate center of the chart. You can start the chart by moving the control lever down. This will record at the rate of 3 in. on

the chart per 1 yd of sliver. If you move the lever up, the tester will record 1 in. on the chart for 1 in. of sliver.

#### Sliver Test Charts

86. Sliver test charts, as illustrated in Fig. 31, contain horizontal lines. The actual size of the chart has been reduced for the illustration. In reality, the chart paper is divided by light horizontal lines spaced 0.1 in. apart. Each horizontal division will, because of the construction of the tester, represent a variation of 0.001 in. in the sliver tested. Every fifth horizontal line is a heavy line to help in reading the chart. The center line is also drawn heavy and is marked 0. The heavy lines above or below this center line are marked in the following order: 5, 10, and 15. Therefore, a line marked 5 and located above the center line indicates that the sliver at this point is 0.005 in. thicker than the thickness of the sliver desired. A line marked 5 and located below the center line represents a sliver 0.005 in. thinner than the sliver desired.

The chart illustrated in view (*a*) is called an inch-by-inch chart, or simply a 1:1 chart. This chart has vertical lines too. The vertical lines are 1 in. apart and each third line is heavy. Therefore, each heavy vertical line will represent 3 in. of sliver, while the light vertical lines represent 1 in. of sliver.

In the chart shown in view (*b*), the variations occurring in 1 yd of sliver are recorded in a space of 3 in. Therefore, each heavy vertical line now represents 1 yd of sliver. The light vertical lines, of course, show  $\frac{1}{3}$  yd, or 12 in., of sliver. Consequently this form may be called a 1:12 chart.

The two kinds of charts can be distinguished from each other only by the characteristics of the line plotted. A 1:1 chart has a plotted line that is relatively smooth, with gradual changes or trends in direction, as shown in view (*a*). The regular chart made in most test runs records 1 yd of sliver in 3 in. of chart length. Thus, the variations found in 12 in. of sliver must be crowded into a space 1 in. long on the chart. The

result, shown in view (*b*), is a plotted line that is more irregular. The same chart paper is used for either of the two forms of charts; the only difference is in the speed with which the chart is drawn past the pen.

#### Reading the Tester

87. The first calculation you need in evaluating a sliver chart is that of the average thickness of the sliver. The adjusting screw, Fig. 30, has its circumference divided into ten divisions. One complete turn of the adjusting screw will raise the rack and move the pin by 0.01 in. Therefore, each division on the adjusting screw represents 0.001 in. in the sliver diameter. The rack has a number of teeth cut on its face. The teeth fit in the notches on the disk. Each notch represents 0.01 in., and alternate notches are numbered. Therefore, the notch marked 6 would represent 0.06 in., while the notch between 6 and 8 will indicate 0.07 in. When the notch on the disk and the line marked 0 on the rack are opposite each other, the top roll, fitting into the groove on the lower roll, will be resting on the bottom of the groove.

As you start the sliver tester, hold the pen at the height equal to the center line of the chart, and allow the rack to engage with the gear. Next, stop the machine, and bring the pen to the center line by means of the adjusting screw. Now read the number of the line on the rack opposite the notch in the disk; let's take 4 as an example. Note the division on the adjusting screw under the pointer shown in Fig. 30; let's take 9 as an example. The thickness of this sliver would be read as 49. Expressed in inches, it would be 0.04 in. + 0.009 in., or a total thickness of 0.049 in. This figure represents the average thickness of the sliver, or the distance the rolls are held apart by it.

When you make calculations from various chart values you had better make all readings in whole figures and forget about the decimals. For example, in reading the average thickness

of the sliver, it is much easier and simpler to read 49 than it is to change it to its correct unit, that is, 0.049 in. In short, while you should be aware of the actual values, simplify the calculations as much as you can.

#### Maximum Variation

88. To find the maximum variation in thickness of a sliver, count the number of lines between the highest and the lowest points of the plotted line on the chart. Actually, this is finding the difference in thickness of the sliver, or the maximum variation of the sliver between its thickest and its thinnest point. For example, suppose the maximum peak of the plotted line rises to the seventh line above the center line, and the lowest point is 3 lines below the center. Although each line is spaced 0.1 in. from adjacent lines, it represents a variation of 0.001 in. The total variation in this case would be 0.007 plus 0.003, or a maximum variation of 0.010 in. This may be expressed simply as 10.

To find the maximum variation in a length of roving, expressed as a per cent, you can use either a rule or a formula.

**RULE:** Divide the maximum variation by the average thickness and multiply the quotient by 100.

$$\text{FORMULA:} \quad A = \frac{B \times 100}{C}$$

in which  $A$  = maximum variation as per cent;

$B$  = maximum variation as read from chart;

$C$  = average thickness of sliver.

**EXAMPLE.** The average thickness of a sliver was found to be 50. The maximum variation reads 7.5. What is the maximum variation expressed as a per cent?

$$\text{SOLUTION.} \quad A = \frac{7.5 \times 100}{50} = 15\% \text{ maximum variation. Ans.}$$

**Average Variation**

89. You can get the best information from the sliver charts when a reliable index is used to designate the uniformity of the sliver. The maximum variation in sliver weight has little use as an indication of sliver evenness because the sliver may be excessively thick in one place, while throughout the rest of its length the thickness may not vary greatly. Under such conditions you don't get a true indication of sliver uniformity.

The thickness of a sliver generally varies unit for unit of length. The plotted line showing the variations in thickness of the sliver will usually vary as shown in Fig. 31 (*a*). The line may first tend toward the heavy side, then toward the light side, but it will always show a tendency toward unevenness. Therefore, at one point the sliver may be heavy, and at another point a few inches away it may be light. By averaging the variations in thickness of the sliver over short units of length, the average of the variations in the sliver is obtained. This gives a true indication of the sliver variation in thickness, and it therefore serves as a measure or an index of approximate variation and unevenness of the sliver.

To find the average variation of a sliver, expressed as per cent, you can use either a rule or a formula.

**RULE:** Multiply the sum of the maximum variations per unit of length by 100, and divide the result by the product of the length of the sliver multiplied by the average thickness.

$$\text{FORMULA:} \quad D = \frac{F \times 100}{G \times C}$$

in which  $D$  = average variation as per cent;

$F$  = sum of the maximum variations per unit of length;

$G$  = number of unit lengths tested;

$C$  = average thickness of sliver.

**EXAMPLE.** Suppose you have tested 5 yd of sliver and use the yard as the unit. That is, you read the maximum variation in each

of the 5 spaces between heavy lines covered on the test chart. The readings are: 5.5, 4.8, 6.0, 5.8, 5.0. The average thickness of the sliver is 50. What is the average variation expressed as per cent?

$$\begin{array}{r} \text{SOLUTION.} \quad 5.5 \\ \quad \quad \quad 4.8 \\ \quad \quad \quad 6.0 \\ \quad \quad \quad 5.8 \\ \quad \quad \quad 5.0 \\ \quad \quad \quad \hline \quad \quad \quad 27.1 \end{array}$$

$$D = \frac{27.1 \times 100}{5 \times 50} = 10.84\% \text{ average variation. Ans.}$$

#### Evaluating Results

90. You can get an excellent indication of sliver evenness by subtracting the average variation from the maximum variation and comparing the result with the average variation. This form of test is useful in evaluating the results obtained from running a sliver test on two different grades or kinds of cotton. Or it may be used for determining the best settings and the correct drafts to use with different types of stock.

The percentages of maximum variation represents the extremes occurring in a given length of sliver. The percentage of average variation represents the average of the maximum variations occurring at definite units of length in a number of yards of sliver. The ideal sliver would be one having both the average variation and the maximum variation equal 0. The sliver would then have absolutely no unevenness. While this ideal state is unattainable, it is highly desirable to have the average variation close to the maximum variation. Therefore, as the difference between these two values diminishes, the sliver evenness will increase.

For example, a test run was made of two lots of cotton at the card. A maximum variation of 20% and an average variation of 10% were found in the sliver of the first lot of cotton.

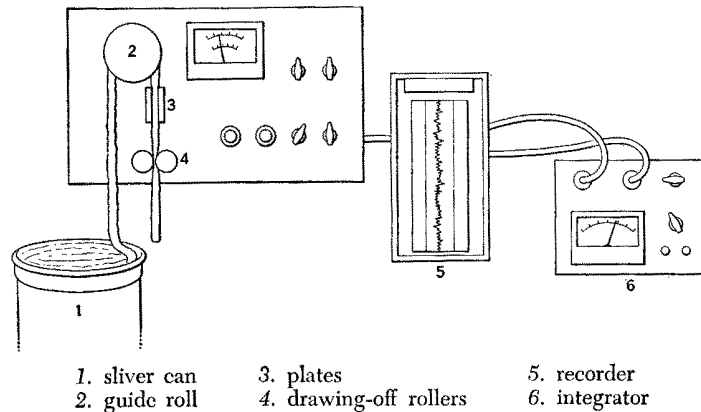

FIG. 32. USTER EVENNESS TESTER

The second lot of cotton showed a maximum variation of 23.5% and an average variation of 10.7%. The difference between the two values in the first case would be 10 and in the second case 12.8. The cotton in the first lot would probably produce the superior yarn because the sliver is more even.

Card sliver ordinarily shows a maximum variation of about 20% and an average variation of about 10%. These percentages are only approximate and do not apply to every card sliver. One sliver may show a great variation and its percentages may be much larger than the percentages mentioned here, or it may be exceptionally even and show only a slight variation. Experience and records will show you how the test results compare with those made on slivers previously produced.

#### Electronic Evenness Tester

91. Every country has a specialty in which it excels. The United States has developed mass-production methods to a remarkable extent; Scotland is famous for its whiskey; and Switzerland has long specialized in precision instruments.

The Uster evenness tester, which can be used for testing the evenness of sliver, roving, and yarn, was developed in Switzerland. It is sold in the United States by the Uster Corporation, Charlotte, North Carolina. The evenness tester, shown in Fig. 32 as set up for testing card sliver, is an electronic measuring instrument. While the instrument is very complex, it is not much harder to use than to tune in a station on a radio or TV set.

As shown in the illustration, the sliver is drawn from the can, guided over a roll, and drawn between two plates by a pair of drawing-off rollers. The sliver is neither drafted nor compressed. The evenness is measured by electric waves passing between the plates. Alongside the measuring instrument is a recorder, which prepares an evenness chart, similar to those you have already studied. An optional instrument, called an integrator, automatically calculates the average variation.

The Uster tester can be adjusted to run from 2 to 100 yd of material per minute, so you can test a whole canful of sliver in a very short time. The paper speed in the recorder can be adjusted from 0.4 to 10 in. per min. You can readily see how this tester permits you to check the card slivers regularly, and to see variations that occur at distant intervals.

The instructions for operating the tester change somewhat with the different models. However, you can get them from the manufacturer, and there is no point in going into them here. Just remember to let the tester warm up for 10 min before you start, so the electronic tubes will operate at full capacity. What we need now, in connection with carding, is a little practice in evaluating the charts produced in testing card sliver.

#### How Test Charts Can Help You

92. Two characteristic test charts produced by the Uster tester are shown in Fig. 33. The chart shown at (a) is on a scale of 1:72. The sliver was run at 68 yd per min, while



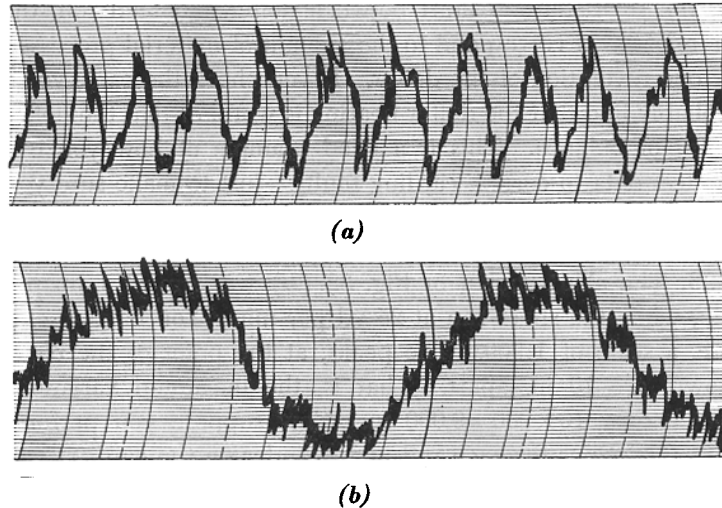

FIG. 33. CHARTS OF IRREGULAR SLIVERS

the paper was run at 4 in. per min. Then,  $8 \times 36 \div 4 = 72$ ; that is, 72 in. of sliver are recorded on 1 in. of paper. You must test at least 5 yd of sliver, a little more than the circumference of the cylinder, to get enough information for it to be significant. For special defects you may have to run over 100 yd before you can trace the pattern. Now let's see how you can use the chart.

In chart (a) you'll notice constant large variations. Measuring from one peak to the next, you see that these cycles are about 1.25 in. apart on the paper. Actually you have thick and thin places in the sliver, about  $1.25 \times 72 = 90$  in. apart. Now remember your mechanical and draft calculations, and go through the card from the delivery end to the feed. The coiler calender rolls have a diameter of 2 in., or a circumference of  $2 \times 3.14 = 6.28$  in., so obviously they are not at fault here. The calender rolls, with a diameter of 3 in., can be ruled out by a similar calculation. This brings us to the doffer.

The circumference of the doffer is  $27 \times 3.14 = 84.8$  in. Allowing for the doffer clothing, which adds to its diameter, and

for the small tension draft between doffer and feed roll, the 90 in. of sliver correspond to the amount of material processed by one revolution of the doffer. If you check the card, you'll probably find that the doffer bearing is worn, or that the doffer is out of balance. This is a good example of how you can use test data to correct carding faults. Just to make sure you understand the method, let's try another example.

93. The chart shown in Fig. 32 (*b*) was run at 1 in. per min, while the sliver ran at 25 yd per min. You have, therefore, a scale of 1:900. The peaks, at the point of the chart shown, are 10 in. apart. That is, the maximum variations stretch over  $10 \times 900 = 9,000$  in. Now suppose you perform the calculations for each roll and cylinder on the card. Even allowing for the drafts, you don't get as much as 9,000 in. But don't give up. Go on to the lap, which is on the lap roll. The lap has a diameter of 24 in. The card has a draft of 120. Then,  $24 \times 3.14 = 75.4$ , and  $75.4 \times 120 = 9,050$ , which is quite close to the 9,000 you were looking for. Like the Canadian Mounted Police, the scientific test methods get the culprit every time. In this case the carder can relax and let the picker operator find out why the lap was uneven.

#### Counting the Neps

94. One problem that plagues the carder is the formation of neps. As you know, neps are small bunches of cotton fiber that are tightly curled together. All through your study of carding, you have learned how to curb the formation of neps through accurate settings and proper maintenance of the card clothing. Now let's see how you can count the quantity of neps made in the card web.

For testing purposes, you must take a sample of the card web. Place this sample on a black cardboard, or a cardboard covered with black cloth. Avoid distorting the web, so that it gives you a representative distribution of neps. You can

then place a pick counter on the web, and count the neps within the 1 in.×1 in. opening. Repeat this on different places, perhaps on 10 or 20 different square-inch spots. You can then determine the average number of neps per square inch.

Another method of counting the neps was developed by the North Carolina State College, School of Textiles. This consists of a metal plate into which 20 circular holes are cut. Each hole has a diameter of 1.128 in., or roughly  $1\frac{1}{8}$  in., that is, it covers an area of 1 sq in. (square inch). The surface of the plate is dull black, to provide contrast and avoid eye-strain. The sides of the holes are tapered so that the neps can be easily reached with a needle or pincers for accurate counting. The black cardboard plate with the card web can be clamped to the back of the metal plate.

Remember, then, to compare these three factors at regular intervals: 1) waste, 2) evenness, and 3) nep count. It is only when you compare all three that you can make a proper comparison of the quality in carding.

#### Processing Research

95. The basic purpose of research is quite simple. You have a certain job to do—in our case, carding. Once you know how to go about it, you can go on and on, never thinking of changing your methods. However, competition being what it is, there will always be someone who wants to do the same thing cheaper, quicker, or better. This person uses research to find a means to this end.

Research in the simplest form is conducted every day by every alert textile supervisor who tries to find ways and means of doing a better job on the process he is in charge of. Also, in many mills there are special departments that devote all of their energy to process research. There are still others interested in progress: the textile machine manufacturers, who want to develop superior machinery that will make

old machines obsolete before they wear out through decades of hard use; the textile colleges, who are looking for support from the industry, and who are anxious to contribute to greater progress; the United States Department of Agriculture, which wants to stimulate the consumption of cotton; and the chemical manufacturing companies, who want to promote the consumption of man-made fibers.

All these different organizations publish the results of their work in the textile trade magazines. You can find these magazines in the reading room of nearly every mill. Or you can subscribe to the magazines at low rates. You will be well advised to subscribe to one of them when you complete your course, in order to keep your knowledge up to date. Your instructor can tell you where to write for the magazines.

#### The Trend in Research

96. Of course, it is impossible to predict the future accurately. However, the trend in textile-processing research during the last few decades has been quite consistent. The chances are that further developments will follow along this same trend.

Textile processing in the past was somewhat along the same lines that you follow when you hunt with a shotgun. The shot spreads all over, and if your aim isn't too far off you may hit something. The idea was something like this: "Beat the cotton through a lot of opening processes, then card it thoroughly. This way it will be good and open. If some of the fibers curl up their toes and die in the form of neps, you can always comb the stock. If the sliver becomes uneven, you simply put it through a lot of drawing and roving processes, in the hope that the thick and thin places will equalize each other." Time was not so important, and wages were lower in those days.

Today it has been established beyond any doubt that over-processing is harmful for the fibers. Fewer processes, care-

fully controlled, will result in better yarn. Now, let's see how this trend to fewer processes affects the carding process.

97. One fact is becoming evident through carefully controlled experiments. It is possible to raise card production—under certain conditions, at least. Experiments have shown that it is possible to speed up the lickerin to the point where its surface velocity almost approaches the surface velocity of the cylinder. Then, if the settings are very close and carefully maintained, if the card clothing is in perfect condition, and if the cotton is of suitable quality, the doffer speed, and therefore the production, can be increased. In the experimental installations, and in some mills too, the quality itself actually increased. That is, the sliver was more even, the amount of waste and the nep count were reduced, and the resultant yarn was stronger. However, as you have noted, there were many “if’s” involved. In mills where any one of the conditions mentioned was not met, the results were very poor.

The conclusions you can draw are simple. If you happen to read about an experiment that worked under controlled conditions, it may or may not work for you. But, remember it when conditions change. You may start to work with another grade of cotton or a new type of man-made fiber. Or perhaps you get new improved cards. At such a time you can experiment with new methods and try out everything you have learned. If you have studied this instruction text carefully, you'll know how to handle the cards, and how to check the results.

*Answers to Practice Problems  
In Article 30*

1.  $\frac{12.5 \times 437.5}{50} = 109.4$  actual draft.    Ans.
2. (a)  $\frac{165 \times 18 \times 2.25}{6.5 \times 18 \times 214} = 0.267$  doffer constant.    Ans.  
       (b) 1,581 draft constant. The gearing between cylinder and doffer doesn't enter the draft calculations, so the constant remained unchanged.    Ans.
3. (a)  $1,581 \div 108 = 14.6$ , or 15-tooth draft gear.    Ans.  
       (b)  $1,581 \div 15 = 105.4$  mechanical draft.    Ans.
4.  $\frac{105.4 \times 100}{100 - 2} = 107.6$  actual draft.    Ans.
5.  $\frac{12.5 \times 437.5}{107.6} = 50.8$ , or approximately 51-grain sliver.    Ans.
6.  $6.5 \div 0.267 = 24.3$ , or 24-tooth production gear.    Ans.
7. The production formula is the same as in Art. 26; that is, 0.0216 is used as the constant. Therefore:
 
$$6.4 \times 50 \times 0.0216 = 6.91 \text{ lb per hr}$$

$$6.91 \times 3 \times 40 = 829 \text{ lb per week}$$

$$20,000 \div 829 = 24.1, \text{ or } 24 \text{ cards.    Ans.}$$

# Carding Practices: Cotton and Synthetics

Serial 6202

Edition 1

## *Examination Questions*

Notice to Students.—Study this instruction text thoroughly before you answer the following questions. Read each question carefully and be sure you understand it; then write the best answer you can. If the answer involves a mathematical solution, show enough of your work to indicate how you obtained your answer. We will not accept answers alone. When you complete your work, examine it closely, correct all the errors you can find, and see that every question is answered; then mail your work to us. DO NOT HOLD IT until another examination is ready.

1. You need 55-grain card sliver, and the picker lap you have available weighs 15 oz per yd. What actual draft is needed on the card to give you the correct sliver?
2. Suppose that the cards are set up for an actual draft of 120, and that you need 50-grain card sliver. What weight of picker lap will you order from the picker room?
3. Find the mechanical draft between the draft roll and the feed roll in the Whitin card shown in Fig. 5.
4. Find the mechanical draft between the feed roll and the doffer in the Whitin card shown in Fig. 5, when a 32-tooth draft change gear ( $D$ ) is used.
5. Find the mechanical draft between the doffer and the calender roll in the Whitin card shown in Fig. 5.
6. Find the mechanical draft between the calender roll and the coiler calender roll in the Whitin card shown in Fig. 5.

2      CARDING PRACTICES: COTTON AND SYNTHETICS

7. Find the total mechanical draft of the Whitin card shown in Fig. 5, with a 32-tooth draft change gear. Set up a formula and calculate the whole draft in one operation.
8. Check the result you obtained in answering question 7, by multiplying the intermediate drafts you determined in questions 3, 4, 5, and 6.
9. Find the draft constant for the Whitin card shown in Fig. 5.
10. You have a card that is making 50-grain sliver from 12.5-oz lap with a 20-tooth draft gear. You now want to make 55-grain sliver from the same lap, without changing the waste percentage. What draft gear will you use?
11. A card has a doffer constant of 0.535. What production gear will you use to get a doffer speed of approximately 13 rpm?
12. Find the doffer constant for the Whitin card shown in Fig. 5, when the cylinder speed is 165 rpm.
13. You have 24 cards geared like the Whitin card shown in Fig. 5, and the doffer speed on each card is 13 rpm. You are producing 50-grain sliver at 92% efficiency. What will be your production in a 40-hour shift?
14. Suppose you were put in charge of the card room in a mill. On inspecting the cards you find facing on the cylinder clothing of several cards. What would you do to prevent this condition in the future?
15. How would you use the leaf gauges shown in Fig. 7 to get a setting of 0.02 in. between two carding surfaces?
16. Suppose you were taking over the card room from the previous shift. The flats on one of the cards have just been set. How would you check the card before starting it?



17. A card has been stripped properly, but too many burs are found in the web. How can you change a setting on the card to remove more burs?
18. The strippers in a roller-top card are loading up. What can you do to correct this trouble?
19. List four different methods of stripping the card, and two different ways to eliminate stripping. Then explain, in your own words, which method you prefer for stripping the card, or for eliminating the need for stripping. Give at least two reasons for your choice. Your answer should indicate that you have compared the different possible systems, and that you have selected one of them after giving the matter careful consideration.
20. Suppose you make a waste test on a card every two weeks. The normal waste on the type of work run is 6%.

Test A shows the following results: Wt. of Lap—Start, 46 lb 5 oz; Wt. of Lap—Finish, 10 lb 13 oz; Wt. of Sliver, 33 lb 1 oz; Wt. of Sliver Waste, 6 oz; Cylinder and Doffer Strips, 4 oz; Flat Strips, 1 lb 3 oz; Motes and Fly, 8 oz; and Sweepings, 2 oz. The moisture check shows no change in weight.

Determine the per cent of each type of waste. Check the balance. What do the results tell you?
21. Test B on the same card shows the following results: Wt. of Lap—Start, 48 lb 12 oz; Wt. of Lap—Finish, 13 lb 0 oz; Wt. of Sliver, 33 lb 4 oz; Wt. of Sliver Waste, 6 oz; Cylinder and Doffer Strips, 14 oz; Flat Strips, 1 lb 4 oz; Motes and Fly, 8 oz; and Sweepings, 2 oz. The moisture check shows no change in weight.

Determine the per cent of each type of waste. Check the balance. What do the results tell you?

4       CARDING PRACTICES: COTTON AND SYNTHETICS

22. Test C on the same card shows the following results: Wt. of Lap—Start, 45 lb 15 oz; Wt. of Lap—Finish, 10 lb 10 oz; Wt. of Sliver, 33 lb 9 oz; Wt. of Sliver Waste, 6 oz; Cylinder and Doffer Strips, 4 oz; Flat Strips, 1 lb 3 oz; Motes and Fly, 4 oz; and Sweepings, 2 oz. The moisture check shows a 1% gain, due to increased humidity.
- Determine the per cent of each type of waste. Check the balance. What do the results tell you?
23. You have tested 10 yd of sliver on an evenness tester. The yard is used as the test unit. The test readings are: 5.9, 5.6, 5.3, 5.5, 5.0, 4.9, 5.0, 5.5, 5.9, and 5.8. The average thickness of the sliver is 50. What is the average variation expressed as a per cent?
24. Suppose you have run an evenness test on a card sliver. The sliver chart shows a regular fluctuation in evenness at approximately 10-in. intervals. What is likely to be wrong on the card?