

# WOOLEN AND WORSTED WARP PREPARATION

(PART 1)

---

## INTRODUCTION

1. Between the processes of spinning and weaving there are several intermediate operations necessary before the yarn that is to constitute the warp of a fabric can be placed in suitable form for the weaving process. The object of these operations is to place the warp yarn on the loom beam so that it may be readily unwound as the cloth is woven and in a manner best suited for making a perfect fabric in the loom. In order that this object may be accomplished, it is evident that a definite number of threads or warp ends must be wound on the loom beam, according to the specifications of the cloth to be woven, and that each of these threads must be of the same length; that is, the required length of the warp.

To obtain the best results in weaving it is also imperative that each end of the warp shall be laid on the loom beam under the same tension, so that the warp will leave the beam evenly and the threads have a uniform tension while being woven. This is important not only in order to avoid poor weaving or the production of faulty cloth from the loom, but also to produce a fabric so constructed that the subsequent operations will not injure it. For instance, suppose that a fabric is being woven in which all of the warp ends have the proper tension with the exception of a few threads that are wound

*For notice of copyright, see page immediately following the title page*

loosely on the beam. It must necessarily follow that these threads will be woven into the cloth loosely throughout the whole piece, and if the fabric is piece-dyed a light shade, they will dye *darker* than the body of the fabric. The reason for this is that in a thread that is loose in the fabric the fibers do not lie so closely together and so will absorb the dyestuff more readily, thus taking up more of the dye and becoming darker in shade. Even in cases where the goods are not dyed in the piece, there is a strong tendency for a loose thread to show more prominently on the face of the cloth, since it is not drawn down level with the other threads by the tension of the warp. In some fabrics, also, loose threads are liable to cockle, thus producing a serious defect and causing the cloth to be classed as seconds.

**2.** Not only is it necessary when making a warp to have the right number of ends on the beam for the cloth to be woven, but it is also necessary in the preparation of some warps to use differently colored threads and to arrange the pattern of the warp correctly in order that certain effects of coloring may be obtained in the fabric. By examining any piece of cloth that contains threads of different colors in the warp it will be seen that these colors are arranged in a definite order, or **pattern**, which is repeated a certain number of times in the width of the cloth. In order to weave such a cloth, it is evident that the colors in the warp must be arranged in the same order on the beam as they are arranged in the cloth.

**3.** Another operation that is sometimes performed during the preparation of the warp is the application of a suitable dressing compound, or **size**, to the yarn, the object being to glue down the projecting fibers and make the thread smooth, so that the chafing of the reed and harnesses will not wear or rough up the yarn during the operation of weaving.

**4.** When the warp has been wound on the beam in suitable form so as to be readily unwound while being woven, it is next necessary to draw the separate ends of the warp through the harnesses according to the designer's draft and

also to draw the correct number of ends through each dent of the reed. After drawing in and reeding, the preparation of the warp is complete and it is then placed in the loom by the loom fixer and the cloth woven by the weaver.

5. As a summary of the foregoing it may be stated that the yarn that is to compose the warp of a fabric must be wound on the loom beam with an even and uniform tension; the pattern of the warp and the number of ends in the warp must be regulated; the warp may or may not have a suitable sizing compound applied in order to enable it to withstand the weaving process to better advantage; and the yarn must be drawn in through the harnesses and reeded.

6. **Processes Employed in Warp Preparation.**—In order to accomplish these results there are four processes generally employed, the object of which is to ultimately make a warp from the yarn as it comes from the spinning room on bobbins. These processes are: (1) *spooling*, (2)  *Dressing*, (3) *beaming*, (4) *drawing in and reeding*. Although these operations are in reality separate and are so spoken of when considered separately, it is customary to speak of the operations of warp preparation in general as *Dressing*, all of them being conducted in a department known as the *Dressing department*, usually under the charge of the boss weaver, or sometimes in large mills, a boss dresser.

## SPOOLING

### THE SPOOLER

**7.** The first operation necessary in the preparation of a warp is that of **spooling**, the object being to take the yarn from the bobbins on which it is spun, or twisted, and wind it on dresser spools, or jack-spools. These spools are constructed with a long wooden barrel having a head on each end, and are made to hold a certain number of threads, depending on the capacity of the spooler. The machine for spooling the yarn is commonly known as a **spooler**, and is shown in Fig. 1.

**8. Bobbin Stand.**—A bobbin stand similar to that shown in connection with the spooler is always necessary when the yarn is received on bobbins, as is generally the case with woollen yarn. It is for the purpose of holding the bobbin securely, in order to allow the thread to be unwound.

Spoolers and bobbin stands are usually made for 40 ends, but occasionally for 48 ends; the number of ends is regulated by the number of holes in the guide bars of the spooler. Guide bars with a smaller number of holes can be substituted and used if necessary.

**9. Operation.**—The operation of the spooler is as follows, the references being to Fig. 2. The bobbins *a* are placed on fixed pins, or spindles, on the bobbin stand and the yarn is passed behind one of two rods *a*, that serve as guides, and thence over hooks in the top of the stand. From these hooks the yarn passes to another row of hooks in the top of the spooler. The yarn next passes through a perforated guide bar *b* that has a traverse motion and then around two tension rolls *c, d* that are covered with leather having a roughened surface.

From the tension rolls the yarn passes through another traversing guide *e* and is ultimately wound on the spool *f*, the bar *e* being for the purpose of building the yarn on the spool smoothly. The spool is driven by friction with the

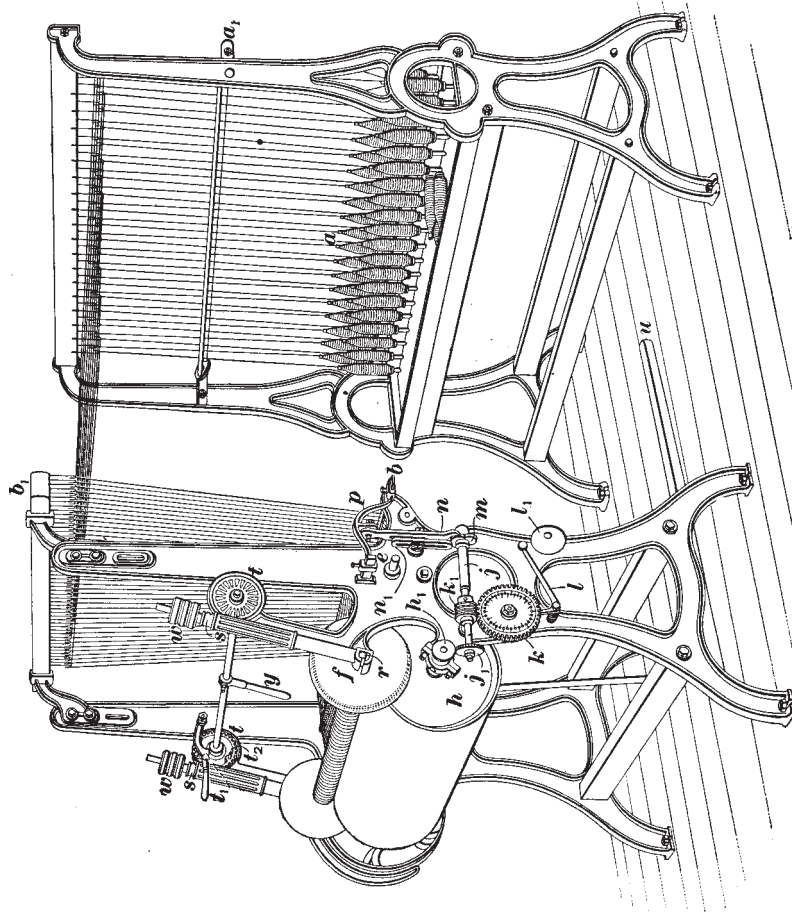

FIG. 1.

drum *h*, on which it is held firmly by means of a device that will be explained later. The drum is exactly 1 yard in circumference, so that at each revolution that it makes, 1 yard of yarn is wound on the spool. The beam *b*<sub>1</sub>, in which the

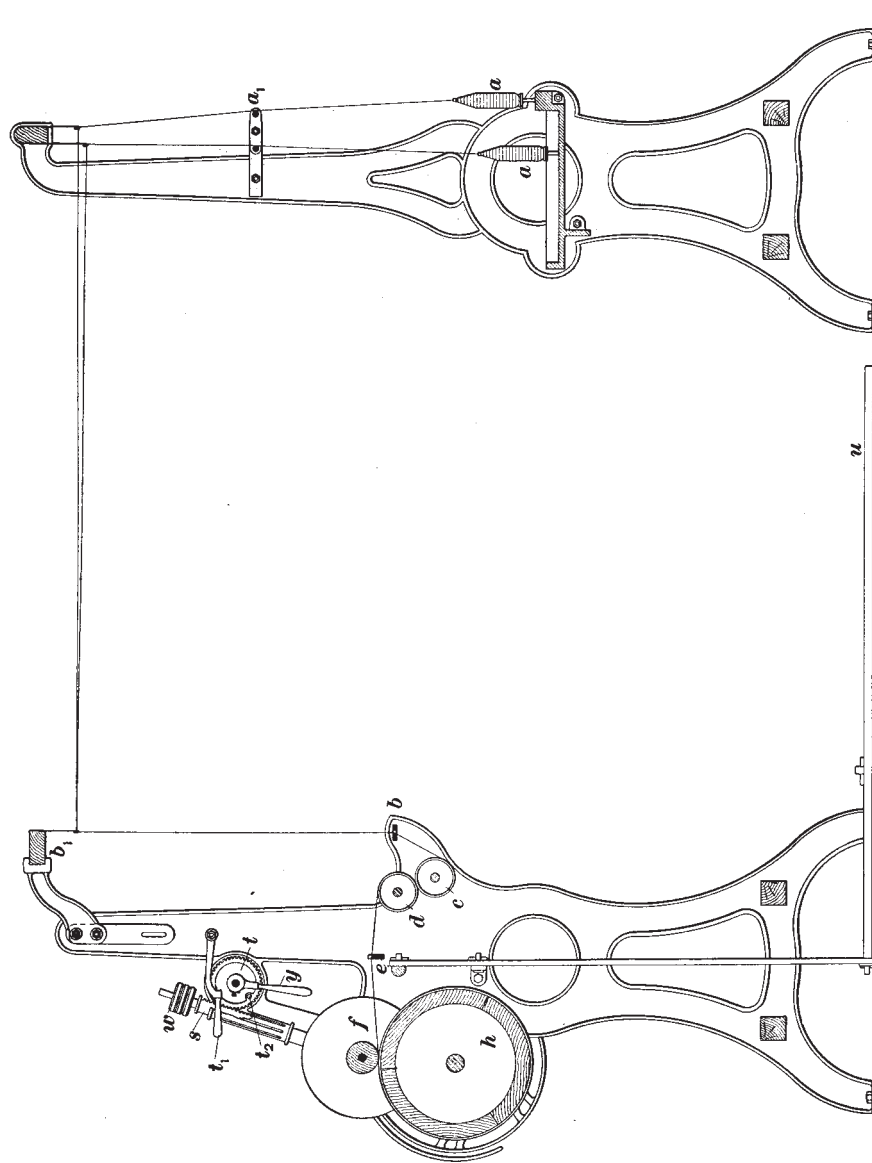

FIG. 2

row of wire hooks is placed, is adjustable by means of slots in its supporting uprights (as shown in Fig. 1), so that if the operative is of small stature it may be lowered in order to facilitate the work when tying in broken ends.

**10. Tension Rolls.**—The tension rolls *c*, *d* are driven only by means of the yarn passed around them; they thus regulate the tension with which the yarn is wound on the spool and also prevent kinks from passing forwards to the spool. The tension may be regulated by the position of the tension roll *d*, which may be moved farther back into another set of slots for increasing the tension or farther forwards to decrease the tension. The tension is also regulated in some cases by means of the frictional resistance of a cord fastened at one end to the framework of the machine; the other end is led around a grooved iron pulley at the end of the tension roll and has a weight attached. In this case more or less tension may be obtained by increasing or decreasing the amount of weight or the length of cord in contact with the pulley.

Although rolls covered with leather are best, many spoolers are equipped only with smooth, polished tension rolls. The guide *b* has a traversing motion, in order that the yarn shall not run in one place and thus wear grooves in the tension rolls, and also to correspond with the movement of the guide *e* and thus reduce the strain on the yarn as it traverses.

**11. Measuring Motion.**—There is a measuring, or clock, motion attached to the spooler, which is shown in Fig. 3, as well as in Fig. 1. On the shaft of the drum *h* is a worm *h*<sub>1</sub> that meshes with a 30-tooth worm-gear *j*<sub>1</sub> attached to a side shaft *j*. Attached to this shaft is a worm *k*<sub>1</sub> that meshes with a dial gear *k*. This gear is marked off so that the number of yards spooled can be readily ascertained. The drum *h* is 1 yard in circumference; the worm *h*<sub>1</sub> is a single-threaded worm; the worm-gear *j*<sub>1</sub> has 30 teeth; and the worm *k*<sub>1</sub> is single-threaded. Therefore, it will be readily seen that each tooth on the dial gear equals 30 yards

of yarn on the spool, and that in order to find the number of yards spooled it is simply necessary to multiply the number of teeth that the dial gear  $k$  moves by 30. This may also be reckoned by means of the scale marked on the dial gear.

There is an *alarm* connected with this mechanism whereby a bell is made to ring when a given number of yards has been spooled. In the dial gear  $k$  there is a row of holes, in any one of which a peg  $l_2$ , Fig. 4, may be placed. This peg

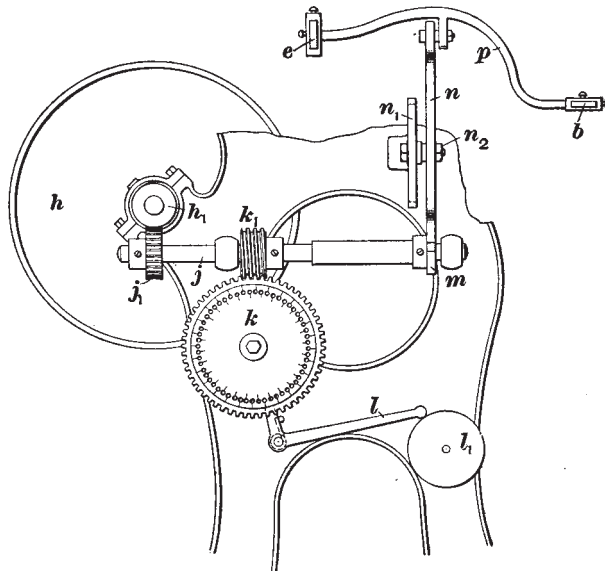

FIG. 3

when brought around by the rotation of the dial gear raises a hammer  $l$ , which is pressed against the bell  $l_1$  by a coil spring upon the stud on which the hammer is centered. When the peg slips past the hammer, it will fall against the bell, thus notifying the operator that the desired number of yards have been spooled. It will be readily seen that the bell may be made to ring when any multiple of 30 yards of yarn has been spooled by simply placing the peg in the correct hole in the dial gear.



**12. Traverse Motion.**—One of the most important parts of a spooler is the traverse motion. Referring to Figs. 1 and 3, it will be seen that the guide bars *b, e* are connected outside of the frame of the machine by a curved bar *p*. By this means the guide bars are made to move in unison, thus not only keeping the tension rolls free from grooves and building a level spool but also at the same time avoiding unnecessary strain on the yarn. The recipro-

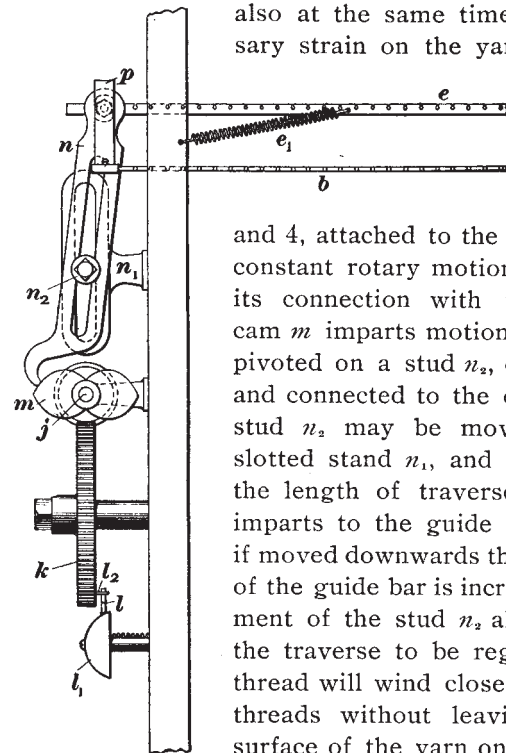

FIG. 4

ating motion of the guide bars is obtained by means of a double heart cam *m*, Figs. 3

and 4, attached to the shaft *j*, which has a constant rotary motion imparted to it by its connection with the drum *h*. The cam *m* imparts motion to a lever *n* that is pivoted on a stud *n2*, on which it swings, and connected to the curved bar *p*. The stud *n2* may be moved vertically in a slotted stand *n1*, and if moved upwards the length of traverse that the lever *n* imparts to the guide bar *e* is reduced, or if moved downwards the length of traverse of the guide bar is increased. This adjustment of the stud *n2* allows the length of the traverse to be regulated so that each thread will wind close up to the adjacent threads without leaving hollows in the surface of the yarn on the spool, and also without overlapping or being wound over the adjacent threads. Sometimes when

making a pattern on the dresser a full spool is not wanted, in which case it may be desirable to alter the length of traverse. Suppose that it were necessary to have only 20 ends on a spool; then a thread could be drawn through every other hole in the guide bars and the traverse

increased to twice the original throw. This is not often done, however, and many operators would simply draw the 20 ends either in the middle or at one end of the spool, running perhaps an odd waste end of a different color at the side of the desired ends to keep them from slipping down. A spring  $e$ , tends to pull the guide bar  $e$  toward the side of the machine, and as the guide bar is connected to the lever  $n$ , the lower curved end of the lever  $n$  is constantly pressed against the face of the cam  $m$ .

As the cam revolves it will alternately allow the point of the lever  $n$  to move closer to or be forced farther from the shaft  $j$ , which will give a corresponding traversing movement to the guide bars  $b, e$ . As the cam  $m$  is a double one, it will cause two complete traverses of the guide bars to be made for each revolution of the shaft  $j$ .

**13. Spool-Holding Device.**—In order that a rotary motion may be imparted to the spool so that the yarn will be wound on the same, it is necessary that the spool shall be held in contact with the rotating drum with sufficient pressure to drive the spool by the frictional contact between it and the drum. It was formerly the custom to obtain this pressure by hanging weights with iron hooks upon the gudgeons, or journals, of the spool. The objection to this method is that it is apt to wear out the spools rapidly by loosening and otherwise damaging the journals, and is also inconvenient in the operation of the machine. A better method of holding the spool firmly in contact with the drum is that employed on the spooler shown in Fig. 1. In this case the journals of the spool are carried on bearings  $r$  formed in the ends of racks  $s$ . Weights  $w$  fastened to extensions of these racks exert a pressure on the journals of the spool and keep the latter in contact with the drum  $h$  with sufficient pressure to prevent slipping.

In order that the spool may be raised from the drum when replacing a full spool with an empty one, two gears  $l$  are fastened to a shaft passing across the machine. These gears mesh with the rack, and when the handle  $y$  is raised,

the racks and the spool also will be raised from contact with the drum. A pin  $t_2$  on the gear  $t$  engages with the dog  $t_1$ , so that when the spool has been raised it is prevented from dropping again until the dog  $t_1$  is disengaged from the pin.

Occasionally it will be found that there is some tendency for the spool to slip on the drum of the spooler, especially if the drum has become very smooth through wear. The clock of the measuring motion is therefore liable to register a greater length of yarn than is actually wound on the spool. A good way to prevent the spool from slipping is to wind a strip of rough leather around the drum until its surface is completely covered. Fillet card clothing with the teeth removed is a good material to use for this purpose. Covering the drum with leather not only prevents slipping, but also increases the diameter of the drum slightly, so that there is no danger of the amount of yarn on the spool being less than registered by the clock.

**14. Belt Shipper.**—Beneath the spooler, as shown at Fig. 1, there is a lever  $u$  pivoted on a pin projecting from the floor and connected with the belt guide, by means of which the belt may be shifted upon the tight-and-loose pulleys by the foot of the operator, thus allowing the machine to be stopped very readily for the purpose of tying in broken threads.

**15. Speed.**—The main driven pulleys of a spooler are usually from 12 to 14 inches in diameter, and for good results should run from 100 to 120 revolutions per minute.

**16. Stop-Motion.**—Nearly all modern spoolers are equipped with a stop-motion, which is a device for stopping the machine immediately when one of the bobbins becomes exhausted or a slug or tangle in the yarn causes an end to break. This motion therefore prevents imperfect spools from being made, since it will be seen that if the machine is not immediately stopped when an end breaks or runs out, many yards of thread will be missing on the spool because of the high velocity at which the drum of the spooler is driven. When this happens, the operator finds the broken

end and repairs it, of course without unwinding the yarn that has been spooled on other parts of the spool in the interval of time between the breaking of the thread and the stopping of the machine, with the result that the spool has one end that is several yards shorter than the others. If the broken end is much shorter than those on either side, it leads to another defect; for in this case a hollow of considerable depth is formed in the spool and the ends on each side have a tendency to fall into this and wind over the short end after it has been pieced up. When such a spool is placed in the creel behind the dresser, there will be difficulty in making it unwind properly without some of the ends becoming broken and imperfect work resulting.

Fig. 5 (*a*) and (*b*) shows a stop-motion applied to the ordinary type of woolen and worsted spooler. On the main shaft of the machine, which carries the drum *h*, an eccentric *l* is placed just inside the frame and on the pulley side of the machine. This eccentric imparts motion to an arm *l*<sub>1</sub>, to which a casting *l*<sub>2</sub>, having an inverted V-shaped slot in one end, is bolted. An oscillating rod *j*<sub>1</sub> extending across the entire width of the machine is supported from a shaft *j*<sub>2</sub> by arms, one of which *j* extends below the shaft *j*<sub>2</sub> and has a pin *j*<sub>3</sub> fastened at its lower end. The pin *j*<sub>3</sub> passes through the slot in the casting *l*<sub>2</sub>, and as the rod *l*<sub>1</sub>, *l*<sub>2</sub> has no support except from the eccentric *l* and the pin *j*<sub>3</sub>, the upper part of the slot in *l*<sub>2</sub> rests loosely on the pin *j*<sub>3</sub> during the ordinary working of the machine. As the eccentric revolves, motion will be given to the pin *j*<sub>3</sub> and the lever *j* will be moved forwards and backwards about its fulcrum at *j*<sub>2</sub>, and the rod *j*<sub>1</sub> will consequently have an oscillating motion. Each end *a* that is being spooled is threaded through a guide *k*<sub>2</sub> in a drop finger *k*<sub>1</sub>, which is supported loosely by a rod *k*<sub>1</sub> extending from one side of the spooler to the other. Each drop finger is independent of the others, and can swing on the rod *k*<sub>1</sub>. Besides having a guide for the thread to pass through, each finger is made with a projection *k*<sub>3</sub> extending downwards, and constantly tending to pull the finger down by its weight. The tension of the thread is sufficient to hold

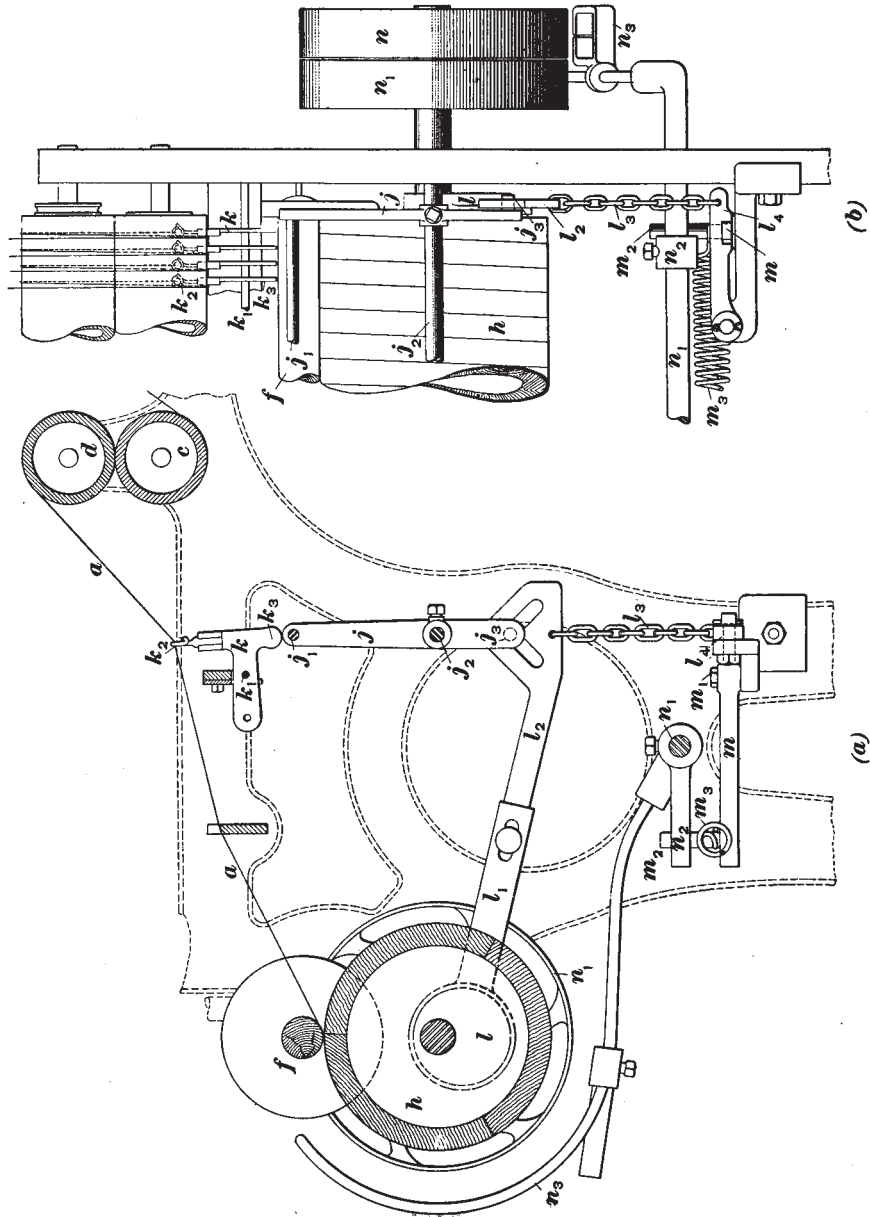

FIG 5

the drop finger in a raised position during the ordinary working of the machine, in which position it is impossible for it to come in contact with the oscillating rod  $j_1$  situated just beneath it; but, if for any reason the thread should become broken or missing, the drop finger will fall, since it is so weighted as to be supported only by the thread. Whenever this happens, the extension  $k_3$  on the drop finger will come in contact with the oscillating rod  $j_1$  and check its motion; the lever  $j$  will therefore also be held firmly, and, since the eccentric  $l$  is not stopped and the pin  $j_3$  is held fast, the casting  $l_2$  rises because of the upper edge of the slot being forced past the pin  $j_3$ . As the slot provides an inclined surface on either side of the pin  $j_3$ , it is immaterial on which side of the extension  $k_3$  on the drop finger the rod is engaged. When the casting  $l_2$  rises it will tighten a chain  $l_3$ , which in turn will raise a lock lever  $l_4$  and thus release a lever  $m$  fulcrumed at  $m_1$ . At the end of the lever  $m$  is a stud  $m_2$  to which a spring  $m_3$  fastened at the opposite side to the framework of the machine is attached. When the lock lever  $l_4$  is raised and the lever  $m$  released, the spring draws the lever over, and the stud  $m_2$  coming in contact with a finger  $n_2$  set-screwed to the shipper rod  $n_1$  forces the belt from the tight pulley  $n$  to the loose pulley  $n_1$  by means of the guide  $n_3$  through which the belt passes. The finger  $n_2$  does not interfere with the regular shipping of the belt, and when the broken end has been replaced the shipper rod is forced back again, in so doing shipping the belt to the tight pulley and forcing the lever  $m$  back so that it will again be locked by the lock lever  $l_4$ .

If it is desired to make a spool with fewer ends than there are drop fingers, the unused drop fingers must be raised so that they will not stop the machine. This may be accomplished by passing a wire through the holes in the rear of the fingers, the weight of the wire holding the fingers in a raised position; or the fingers may be tied up.

**WORSTED CREEL**

17. When worsted yarn is being spooled, it is usually necessary to substitute a creel for the bobbin stand shown in Fig. 1, since worsted yarn is usually received in the dressing room on small spools. Fig. 6 shows a common type

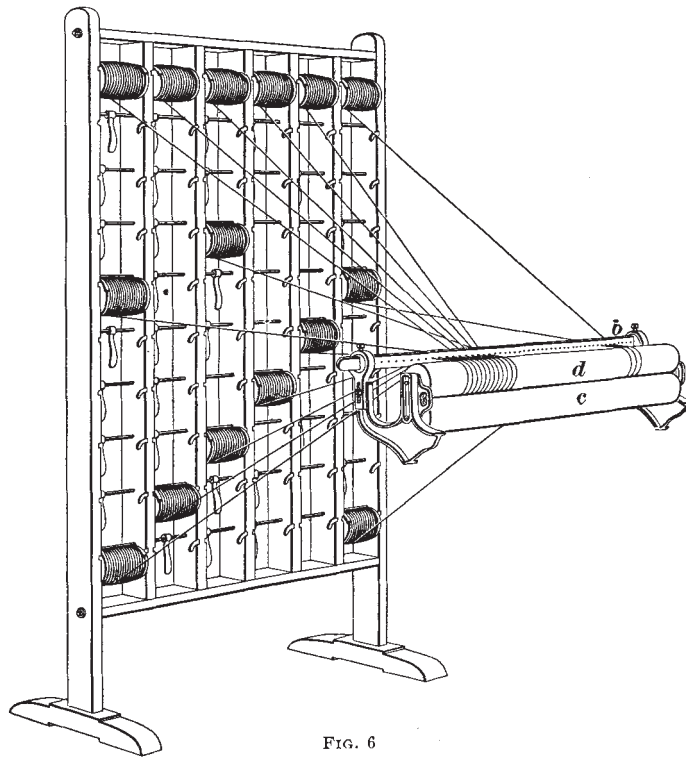

FIG. 6

of creel used for this purpose. It consists simply of a wooden framework arranged so that the spools containing the yarn may be placed on wooden skewers, which are supported in slots cut in the framework of the creel. In order to secure enough friction on the spool to prevent the spool from overrunning when the spooler is stopped, small castings are hung loosely upon rods extending across the creel. These

castings are grooved on the under side so that they will fit over the head of the spool and by virtue of their weight prevent the same from turning too freely. Sometimes instead of iron castings, small wooden paddles are used for placing the friction on the spools. These are usually arranged to rest on the surface of the yarn and not on the head of the spool.

#### THE COMPRESSING SPOOLER

18. In the ordinary type of spooler the hardness of the spool is regulated to a great extent by the amount of tension that is placed on the yarn during the spooling. If any attempt is made to increase the firmness by increasing the weight on the journals, or gudgeons, of the spool, it will result in greater pressure being exerted on the ends than in the center of the spool, as the spool tends to spring at the center. This will make a spool with a greater diameter in the center than at the ends and will result in unsatisfactory warps, since the fact that some ends are wound loose and others tight causes uneven tension. If an increase of the firmness of the spool is obtained by placing a greater tension on the yarn, the results are even more unsatisfactory, since in this case not only will the elasticity of the yarn be injured, but frequent stoppages with consequent loss of production will be necessary on account of the tension frequently breaking the yarn.

It is the object of the **compressing spooler** to overcome these difficulties and to wind the yarn on the spool in such a manner that not only will each thread have the same length, but the spool also will be made much firmer and will contain from 30 to 50 per cent. more yarn than a spool made in the ordinary way. This latter point is of great advantage in itself, since the spools will run longer in the dresser, and consequently the time consumed in tying in new spools and the number of knots in the warp will be reduced to a minimum. Since increased firmness of the spool is obtained by this system without undue tension on the yarn in spooling, the elasticity of the yarn is not impaired in the least, but is



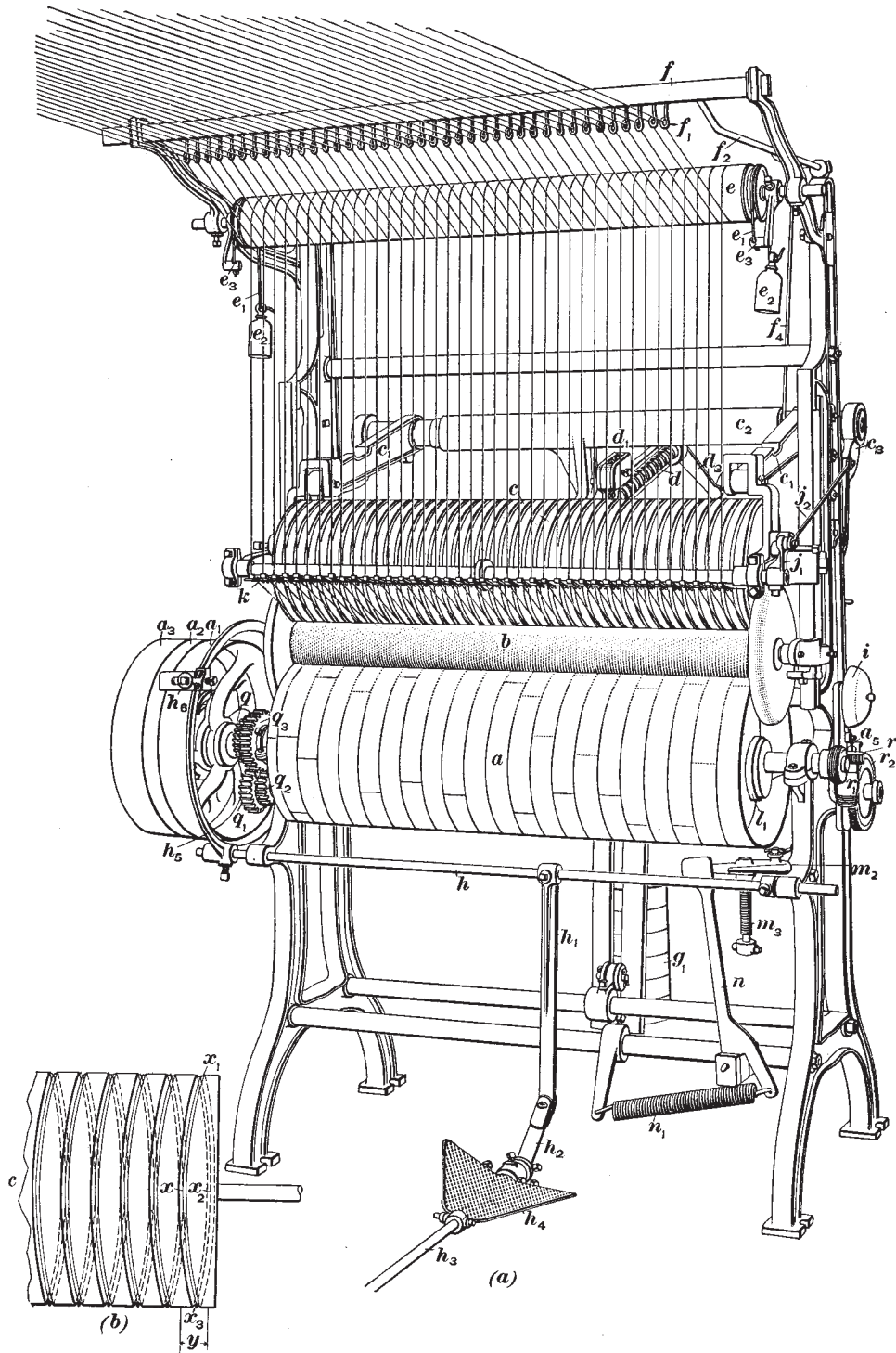

FIG. 7

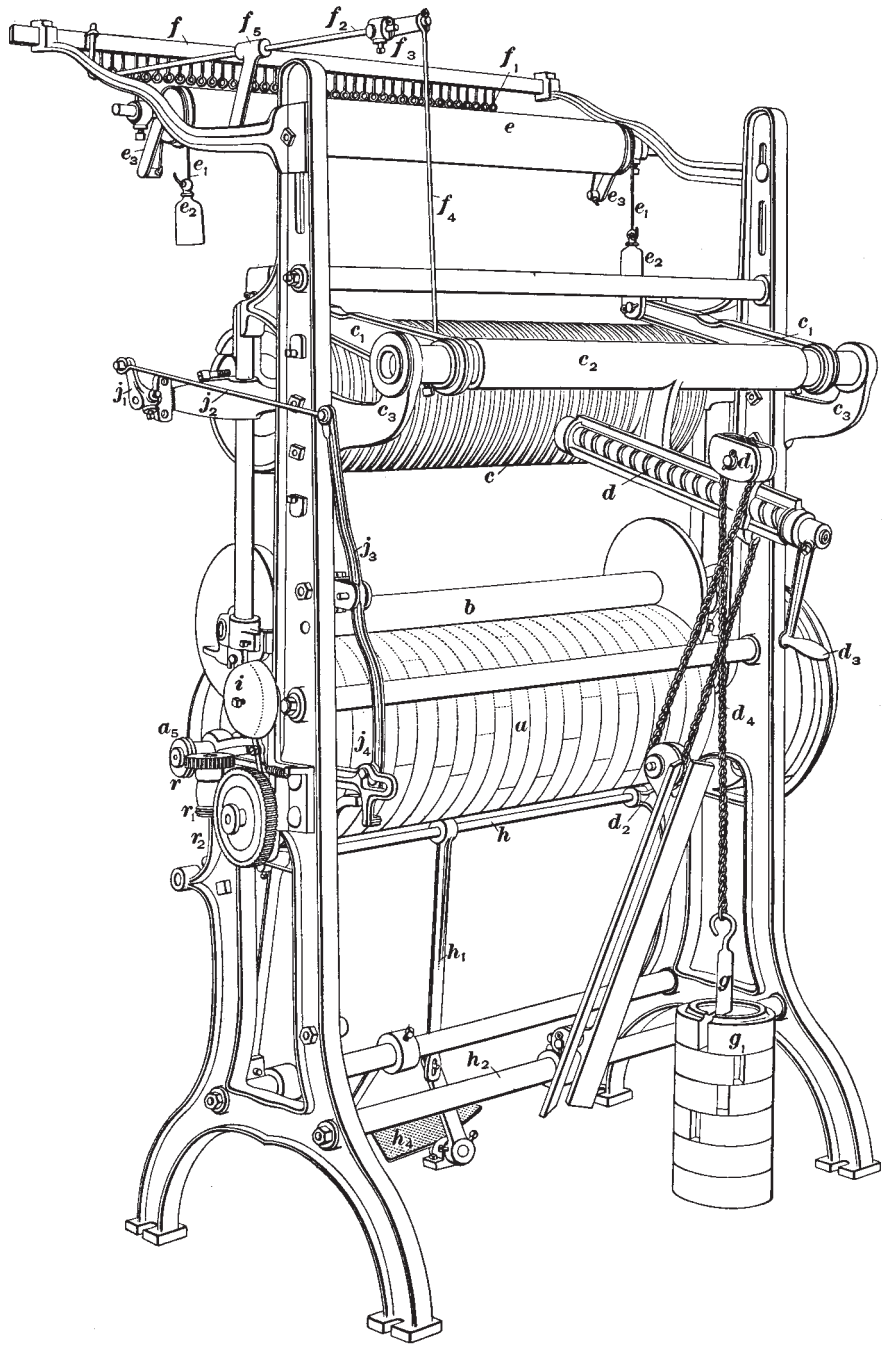

FIG. 8

fully retained. A front view of the compressing spooler is shown in Fig. 7 (*a*), while Fig. 8 shows the appearance of the machine as seen from the rear. It is important to notice that Fig. 7 (*a*) shows the machine in operation, while Fig. 8 shows it stopped for the removal of a full spool.

**19.** The operation of this spooler is as follows: The spool *b*, on which the yarn is wound, is carried on the usual rotating drum *a*, which is covered with a filleting of rough leather. Resting on top of the yarn as it is wound on the spool is a heavy iron compressing roll *c* supported in bearings at the end of two arms *c*<sub>1</sub>, *c*<sub>1</sub>. These arms are attached to a shaft *c*<sub>2</sub> that is journaled in brackets *c*<sub>3</sub>, *c*<sub>3</sub>, which are bolted to the side frame of the machine.

The object of this roller *c* is to exert a heavy pressure on the spool, so that the yarn will be wound in such a manner as to form a firmly compressed spool. The pressure on the yarn is obtained by the weight of the compressing roll itself, and also by means of the weights *g*<sub>1</sub> at the rear of the machine. Carried in a casting that is part of the shaft *c*<sub>2</sub> is a screw *d*, which may be turned by a crank *d*<sub>3</sub>; this screw carries a sliding block *d*<sub>1</sub>, in which a pulley is mounted. Attached to the bottom of the block is a chain *d*<sub>4</sub>, which is led through a pulley *d*<sub>2</sub> attached solidly to the framework of the machine, then back through the pulley in the sliding block and finally to a spindle *g*, upon which a number of weights *g*<sub>1</sub> may be placed, according to the desired pressure to be exerted by the compressing roll. The object of the screw arrangement is to provide for the raising of the compressing roll when it becomes necessary to remove a full spool from the machine and replace it with an empty one.

While the machine is in operation, the compressing roll rests on the surface of the yarn, and the block *d*<sub>1</sub>, being screwed to the end of the screw nearest the compressing roll, passes the fulcrum of the shaft *c*<sub>2</sub> and exerts a downward pressure on the compressing roll, thus holding it firmly on the yarn. When, however, it is desired to raise the compressing roll for replacing the full spool with an

empty one, the block  $d_1$  is screwed back to some such position as is shown in Fig. 8. When this is done, the weight  $g_1$  will operate outside of the fulcrum, and the weight of the compressing roll will be counterbalanced so that it may be raised.

**20. Traverse Motion.**—The compressing roll is cut with a number of grooves corresponding to the number of ends that it is possible to place on a full spool. These grooves take the place of the traversing thread guide in the ordinary type of spooler. They are somewhat **V** shaped and about  $\frac{3}{8}$  inch in depth, and instead of being cut in a true circle around the compressing roll, are cut at an angle, so that as the compressing roll rotates, the grooves have an oscillating motion and the thread is guided back and forth the distance between two rings. By this means, the traverse motion is obtained without any chafing of the yarn as is the case with the traversing guide bar on the ordinary type of spooler.

Fig. 7 (*b*) shows the arrangement of the grooves on the compressing roll and illustrates the principle on which the traverse action of the roll is based. With the roll in the position shown, the thread is being wound on the jack-spool at a point  $x_3$ , exactly in the center of its traverse motion, but as the roll continues to revolve, the point  $x$  will come in contact with the spool and thus guide the thread to the left. The continued movement of the compressing roll will then bring the thread back as the point  $x_1$  is exactly over the point  $x_3$ . Then, as the motion continues, the thread will be carried to the right as the point  $x_2$  is brought in contact with the spool, and so on, until the point  $x_3$  is again reached.

It will be seen that in making a half revolution between the points  $x$  and  $x_2$  and through the points  $x_1$  or  $x_3$ , the thread will be traversed the distance  $y$ , which is equal to the distance between two rings. It will also be noted that the thread is traversed to the right and then back again to the left in one revolution of the compressing roll, that is, it

makes one traverse to each half revolution of the roll; and since the circumference of the compressing roll is 25 inches, one complete traverse is obtained with  $12\frac{1}{2}$  inches of yarn, whereas in the ordinary spooler, 15 yards of yarn is necessary for each traverse. This renders the spool especially firm, and if only a few ends are to be spooled it is unnecessary to run extra ends on each side, since the traverse is so short that the yarn will build up squarely without any support at the sides. Another advantage of this traverse motion is that if, when tying in a broken end, the operator should place the end in the wrong groove of the compressing roll, in one revolution of the roll the thread would be carried back to its proper groove, in which it would drop and continue to run. The reason for this is that the tendency of the thread to stay in the groove is not sufficient to cause it to stay in a groove on either side of the proper one for the reason that the thread is pulled out of its true course and compelled to run in a direction that forms an angle with the direction in which it is inclined to run.

**21. Tension Roll.**—The yarn that is being spooled is taken from a bobbin stand of ordinary construction and passed overhead through wire hooks  $f_1$ , then round a tension roll  $e$ , then through a small porcelain pot eye  $k$  to the spool. The object of the tension roll  $e$  is not so much that of placing tension on the yarn as to regulate the yarn so that the same length of each thread will be delivered. The tension is obtained by means of cords  $e_1$ , fastened to a casting  $e_2$ , and passing over a groove in each end of the tension roll. On the other end a weight  $e_3$  is hung, thus securing the requisite friction. This friction may be easily varied by means of the casting  $e_3$ , which is setscrewed to the stationary shaft of the tension roll  $e$  and may be readily turned in either direction, by loosening the setscrew so that more or less of the cord will be in contact with the tension roll. If more of the cord is in contact with the roll, the friction will be increased, and vice versa. With this type of spooler, very little friction should be placed on the tension roll, since the object of

this machine is compression rather than tension. The tension roll is covered with leather in order that it may firmly grip the yarn, and the bar  $f$  in which the wire hooks are placed is given a slow lateral movement so that the yarn will not wear grooves in the roll. This movement is obtained by means of the rod  $f_4$  attached at one end to the arm  $c_1$  of the compressor and at the other to a casting  $f_3$  setscrewed to the rod  $f_2$ , which is carried in a bearing  $f_5$  bolted to the frame of the machine; the other end of the rod  $f_2$  is bent at right angles to the main part of the rod and engages with the bar  $f$ . As the spool builds, the compressor roll and the arms  $c$  are raised, this motion imparting a slight lateral movement to the bar  $f$  so that it will gradually move to the left in Fig. 8. This traversing motion, of course, is very slow, since only one traverse is made while the spool is building.

**22. Slow Motion.**—A slow motion is attached to the compressing spooler so that the machine may be run at a slow speed while bobbins are being tied in or while the operator is watching for a bobbin to run out. At other times the machine may be run at its maximum speed. The position of this motion is shown in Fig. 7 (*a*), but Fig. 9 shows its construction in detail. The main shaft of the machine, on which the drum  $a$  is fastened, carries three pulleys  $a_1$ ,  $a_2$ ,  $a_3$ ; the pulley  $a_3$  is a tight pulley and is setscrewed to the shaft of the machine; the narrow pulley  $a_2$  is the slow-motion pulley and is loose on the sleeve  $p$ ; the pulley  $a_1$  is a loose pulley and is loose on the same sleeve as the slow-motion pulley. On the inside of the loose pulley and fastened to the sleeve  $p$  is a gear  $q$  meshing with a gear  $q_1$  loose on a stud fastened to the framework of the machine. Compounded with this gear is a gear  $q_2$ , which drives a gear  $q_3$  fastened to the main shaft of the machine. On the other end of the sleeve  $p$  is a ratchet  $p_1$ , which is driven by means of a pawl  $p_2$  fastened to the slow-motion pulley. When the belt is on the loose pulley  $a_1$ , no motion will be imparted to the machine, but when the belt is on the slow-motion pulley  $a_2$ , the pawl  $p_2$

will engage the teeth of the ratchet  $p_1$  and drive the drum  $a$  at half speed through the sleeve  $p$  and the gears  $q, q_1, q_2, q_3$ . When the belt is on the tight pulley  $a_3$ , the machine will be driven at its full speed.

The reason for driving the slow motion with a pawl and ratchet, as shown, is that as the belt takes hold of the tight pulley in being shifted from the slow-motion pulley, the slow-motion pulley, if fast to the sleeve, would begin to run at a speed in excess of that of the tight pulley, because

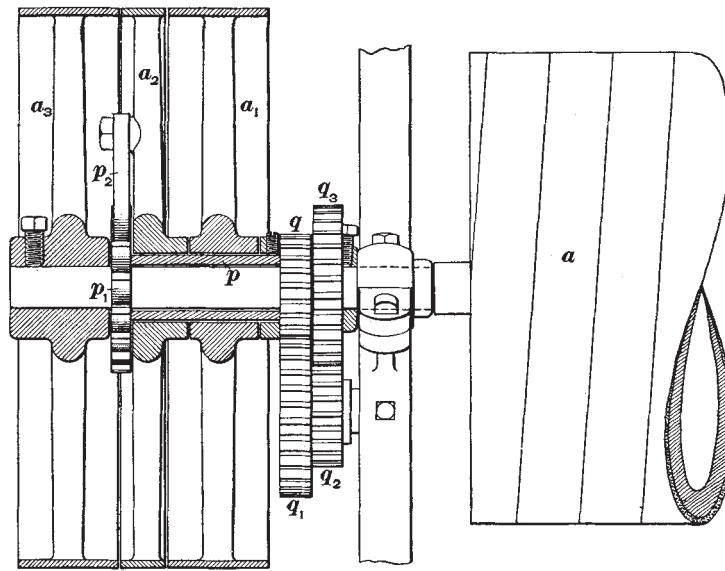

FIG. 9

motion would be imparted to the slow-motion pulley from the pulley  $a_3$  by the gears  $q_3, q_2, q_1, q$ . This letting go of one pulley and taking hold of another would make a jump in the speed, since the slow-motion pulley would act as a brake until the belt was shifted entirely on to the fast pulley, if it were not for the pawl and ratchet. The pawl makes a release, so that as the belt begins to take hold of the tight pulley it releases the slow-motion pulley, which makes the latter act as a loose pulley.



The belt is shifted on the three pulleys by means of the shipper rod  $h$ , Fig. 7 (*a*), on one end of which an iron hoop  $h_s$  is setscrewed. To this hoop an adjustable belt guide  $h_a$  is fastened; this belt guide, together with the hoop, to which it may be fastened in any position, is so constructed that a belt may be guided on the pulleys when delivered at any angle. Attached to the shipper rod is a casting  $h_1$  at the lower end of which is a slot engaging with the lever  $h_2$ , which is attached to a rod  $h_3$  carried in bearings on the floor. A treadle  $h_4$  attached to this rod enables the machine to be easily started or stopped.

**23. Measuring Motion.**—The compressing spooler is equipped with a measuring motion very similar to that previously described. On the main shaft of the machine is a single-threaded worm  $a_s$ , Fig. 10, engaging with a worm-gear  $r$  of 30 teeth. This worm-gear is fastened to a small upright shaft carried in a bearing bolted to the framework of the machine. Fastened to the lower end of the upright shaft is another single-threaded worm  $r_1$  engaging with the dial, or clock, gear  $r_2$ , which contains 100 teeth. In this gear is a pin  $r_3$ , which is for the purpose of ringing a bell  $i$  whenever the desired number of yards has been spooled. This pin comes in contact with a hammer  $i_1$ , forcing it away from the bell  $i$  against the tension of the spring  $i_2$ . As the gear  $r_2$  revolves, the hammer  $i_1$  slips off the pin  $r_3$  and the spring draws it forcibly back, thus ringing the bell. The drum  $a$  is exactly 1 yard in circumference; the worm  $a_s$  is single-threaded; the worm-gear  $r$  has 30 teeth; and the worm  $r_1$  is single-threaded. Therefore, 1 tooth of the dial gear equals 30 yards of yarn wound on the spool, and since the dial gear contains 100 teeth, one revolution of the latter will equal 3,000 yards of yarn spooled. When the pin  $r_3$  is in such a position that the hammer  $i_1$  has just slipped from it and rung the bell  $i$ , the 3,000-yard mark on the dial gear  $r_2$  will be exactly opposite the pointer  $r_4$ , and since one complete revolution of the dial gear will be required before the bell will ring again, it follows that 3,000 yards of yarn, as indicated



by the pointer, will be spooled before the bell rings again. If any other number of yards is desired to be spooled, the dial gear is loosened, removed from the worm  $r_1$ , and

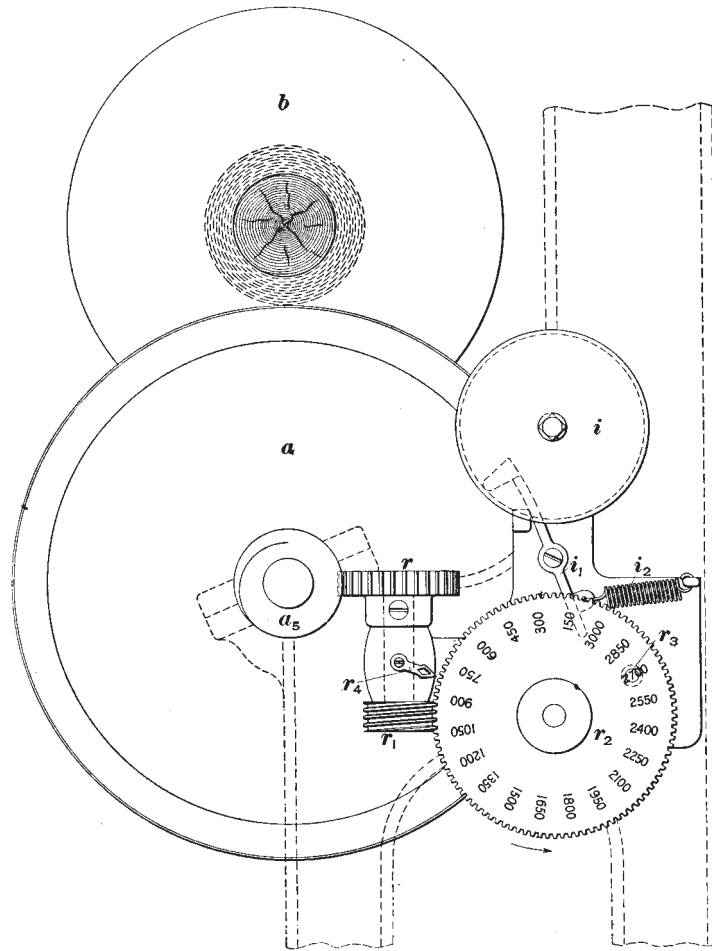

FIG. 10

replaced in such a position that the pointer  $r_4$  will indicate the desired number of yards, which number will therefore be spooled before the bell will ring.

**24. Stop-Motion.**—The compressing spooler is equipped with a very simple and reliable stop-motion for stopping the machine when any thread becomes broken or runs out. This motion is shown in Fig. 11 (*a*) and (*b*), the former showing the device as seen from the side and the latter as seen from the front of the spooler. The yarn in passing to the spool is carried through small porcelain pot eyes in the end of drop fingers *k*, which are so arranged as to be supported by the tension of the thread. These drop fingers are fulcrumed at *k*, and have a small projection designed to engage with the grooved oscillating bar *j*, if for any reason the thread becomes broken and allows the finger to drop. Motion is imparted to the oscillating rod *j* by means of the eccentric *l* on the main shaft of the machine. This eccentric imparts motion to an arm *l*<sub>1</sub>, at the end of which is bolted a casting *l*<sub>2</sub> having a long slot with a **V**-shaped notch at the top. A pin *j*<sub>4</sub> fastened in a lever *j*<sub>3</sub> supports the casting *l*<sub>2</sub> and the arm *l*<sub>1</sub> when the machine is in a normal condition, the pin resting in the **V**-shaped part of the slot. By this means the eccentric imparts an oscillating motion to the lever *j*<sub>3</sub>, which through the connecting bar *j*<sub>2</sub> and the casting *j*<sub>1</sub> setscrewed to the end of the grooved bar *j* imparts an oscillating motion to the latter. Whenever a thread breaks and the drop finger engages the grooved bar, the oscillation of the latter is checked, which in turn stops the lever *j*<sub>3</sub>. The movement of the eccentric then draws in the arm *l*<sub>1</sub> so that the pin *j*<sub>4</sub> will move out of the **V**-shaped slot, in so doing raising the casting *l*<sub>2</sub>. At the end of the casting *l*<sub>2</sub> is a small projection *l*<sub>3</sub>, which ordinarily clears the curved lever *m*; but, when the casting *l*<sub>2</sub> is raised, *l*<sub>3</sub> comes in contact with the end of this curved lever. When this happens, the action of the eccentric will impart motion to the lever *m*, and, through the connecting-rod *m*<sub>1</sub>, to the lock lever *m*<sub>2</sub>. The catch in the end of the lock lever ordinarily holds in position the lever *n*, which is forced against it by a strong spring *n*<sub>1</sub>; but, when the rod *m*<sub>1</sub> is pushed back, the casting is turned on its shaft and releases the lever, which then

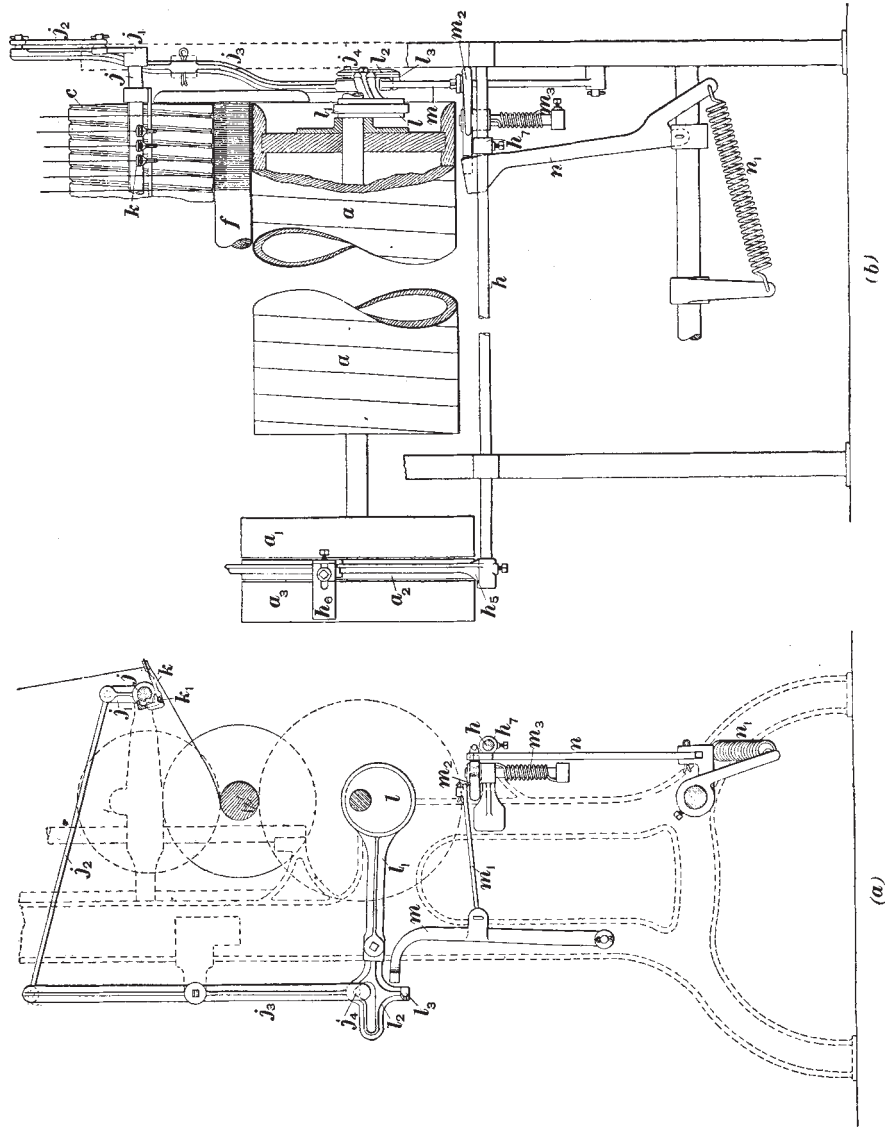

FIG. 11

comes in contact with the collar  $h$ , setscrewed to the shipper rod  $h$ , and by means of the spring  $n_1$  forces over the shipper rod and shifts the belt from the tight to the loose pulley. A spring  $m_3$  is so arranged as to hold the lock lever  $m_2$  in contact with the lever  $n$ , so that the spooler will not be stopped by the vibration of the ordinary running of the machine. A recess in the lock lever receives the lever  $n$  when the machine is stopped by the stop-motion.

# WOOLEN AND WORSTED WARP PREPARATION

(PART 1)

---

## EXAMINATION QUESTIONS

- (1) What four operations are necessary in preparing a warp?
- (2) Explain, fully, why all the threads of a warp should have the same tension.
- (3) What is the object of a spooler?
- (4) How many yards are spooled while the dial gear of a spooler moves 17 teeth? Ans. 510 yd.
- (5) What is the reason for giving the guide bar *l*, Fig. 7 (*a*), a reciprocating movement?
- (6) What is the object of the tension rolls on the spooler shown in Fig. 1?
- (7) What is the usual number of threads wound on a spool?
- (8) How is motion imparted to the spool in a spooler of the usual construction?
- (9) Explain how the mechanism shown in Fig. 5 stops the spooler when a thread breaks or runs out.
- (10) What advantages does the compressing spooler have over a spooler of the ordinary type?
- (11) Describe the principle of the compressing spooler.

(12) What is the object of having the block  $d_1$ , Fig. 8, movable on the screw?

(13) Describe the stop-motion on the compressing spooler.

(14) What length of yarn is required to make the traverse ( $a$ ) on the compressing spooler? ( $b$ ) on the ordinary spooler?

(15) What would happen if a thread was placed in the wrong groove of the compressing roll?

(16) Why is it unnecessary to run extra ends on each side if only a few ends are to be spooled on a compressing spooler?

(17) Describe the slow-motion arrangement.

(18) What is the weight of the yarn on a spool containing 40 ends, if 2,400 yards has been spooled, the yarn being 2/40s worsted? Ans.  $8\frac{1}{7}$  lb.

(19) A spool of woolen yarn contains 40 ends 960 yards long. The spool and yarn together weigh  $10\frac{1}{2}$  pounds, the known weight of the spool being  $2\frac{1}{2}$  pounds. What run is the yarn? Ans. 3-run

(20) A spooler tender spooling 4-run yarn, 40 ends on a spool, is paid  $\frac{3}{4}$  cent per pound. If an average of 2,400 yards per hour is spooled, how much will the tender earn in a week of 58 hours? Ans. \$6.53