

E. B. BIGELOW.

7 Sheets--Sheet 1

No. 6,806.

CARPET-LOOMS.

Patented Oct. 23, 1849.

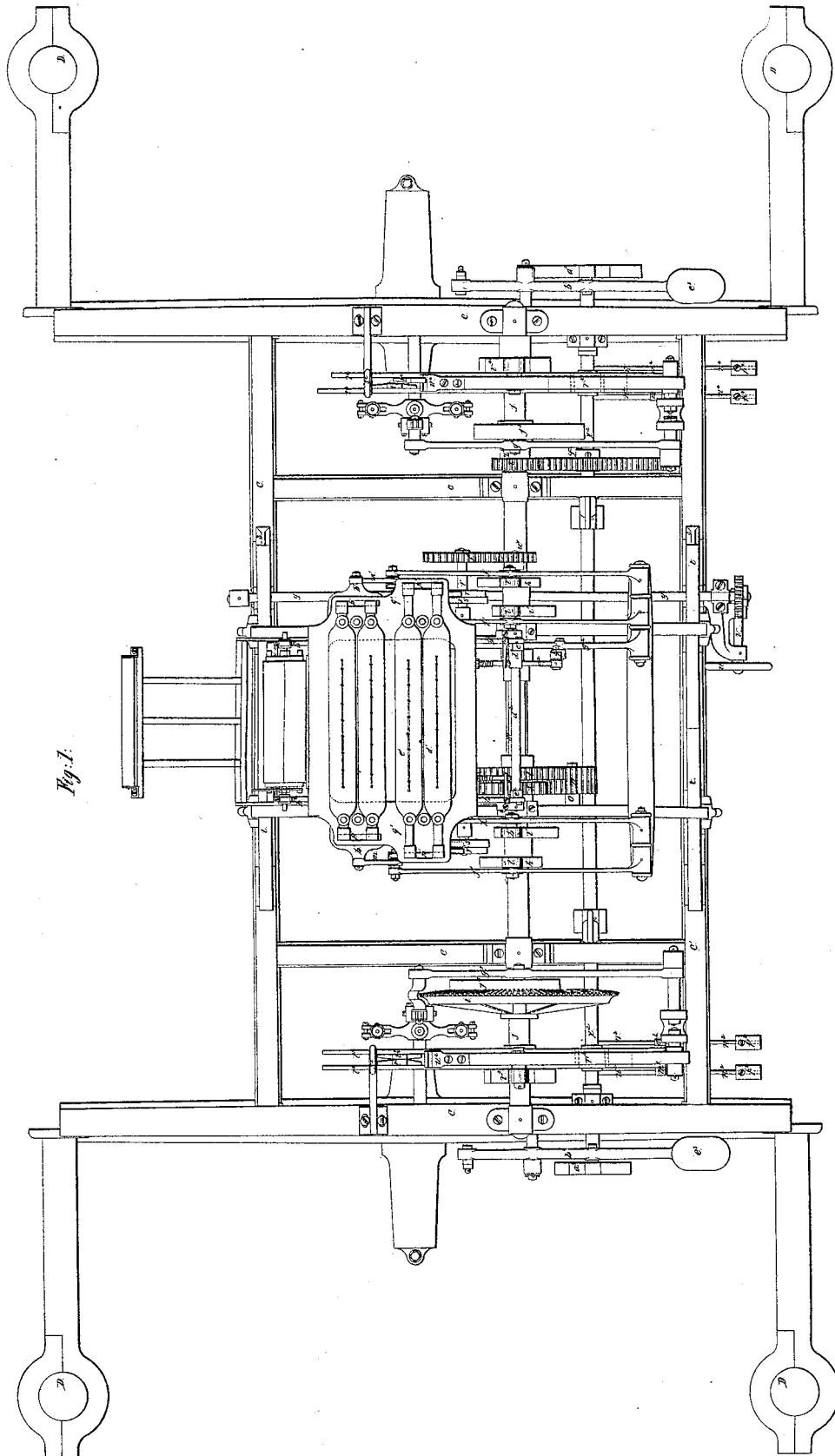

E. B. BIGELOW.

7 Sheets—Sheet 2.

No. 6,806.

Patented Oct. 23, 1849.

CARPET-LOOMS.

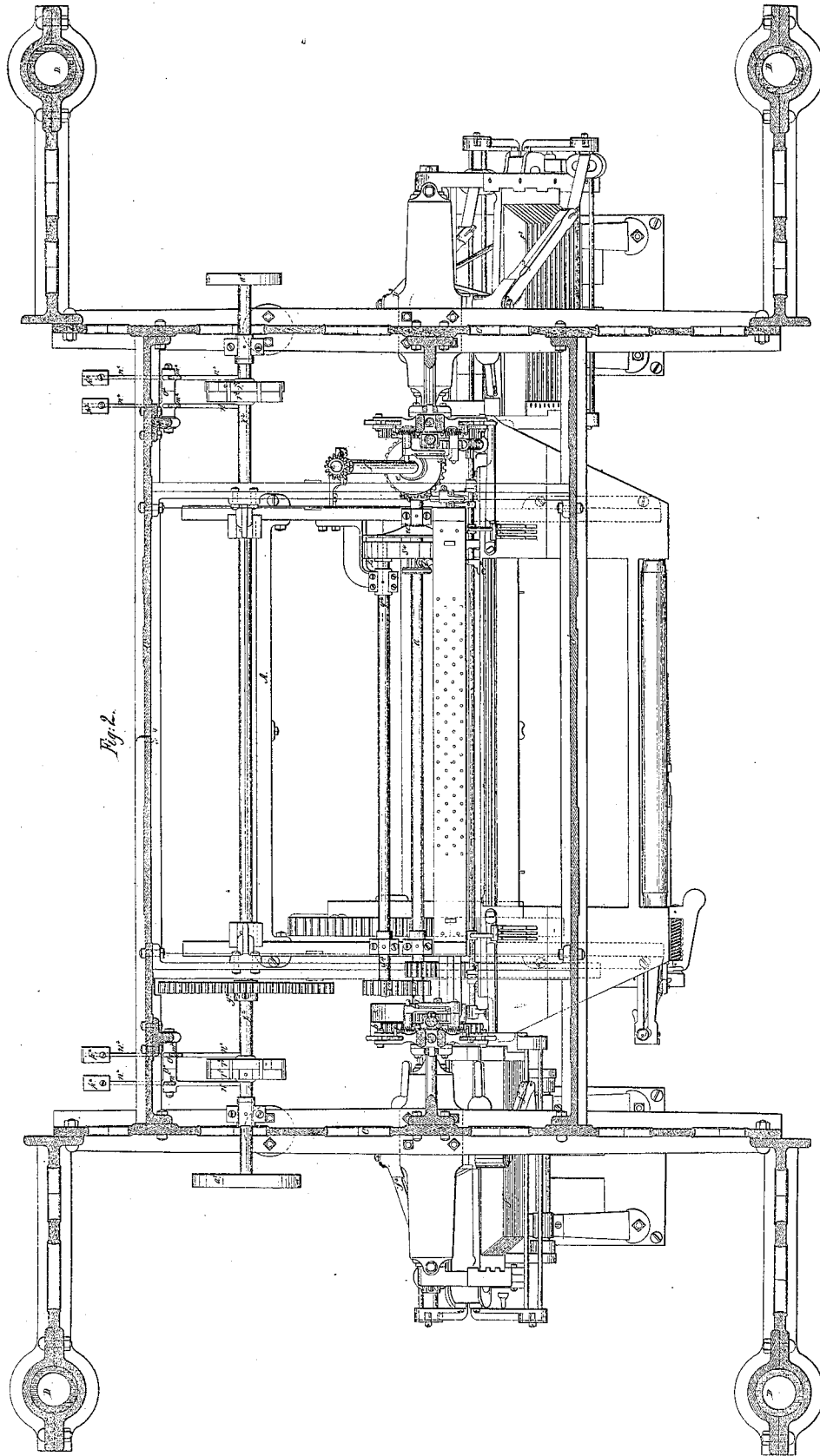

E. B. BIGELOW.

7 Sheets--Sheet 8

CARPET-LOOMS.

No. 6,806.

Patented Oct. 23, 1849.

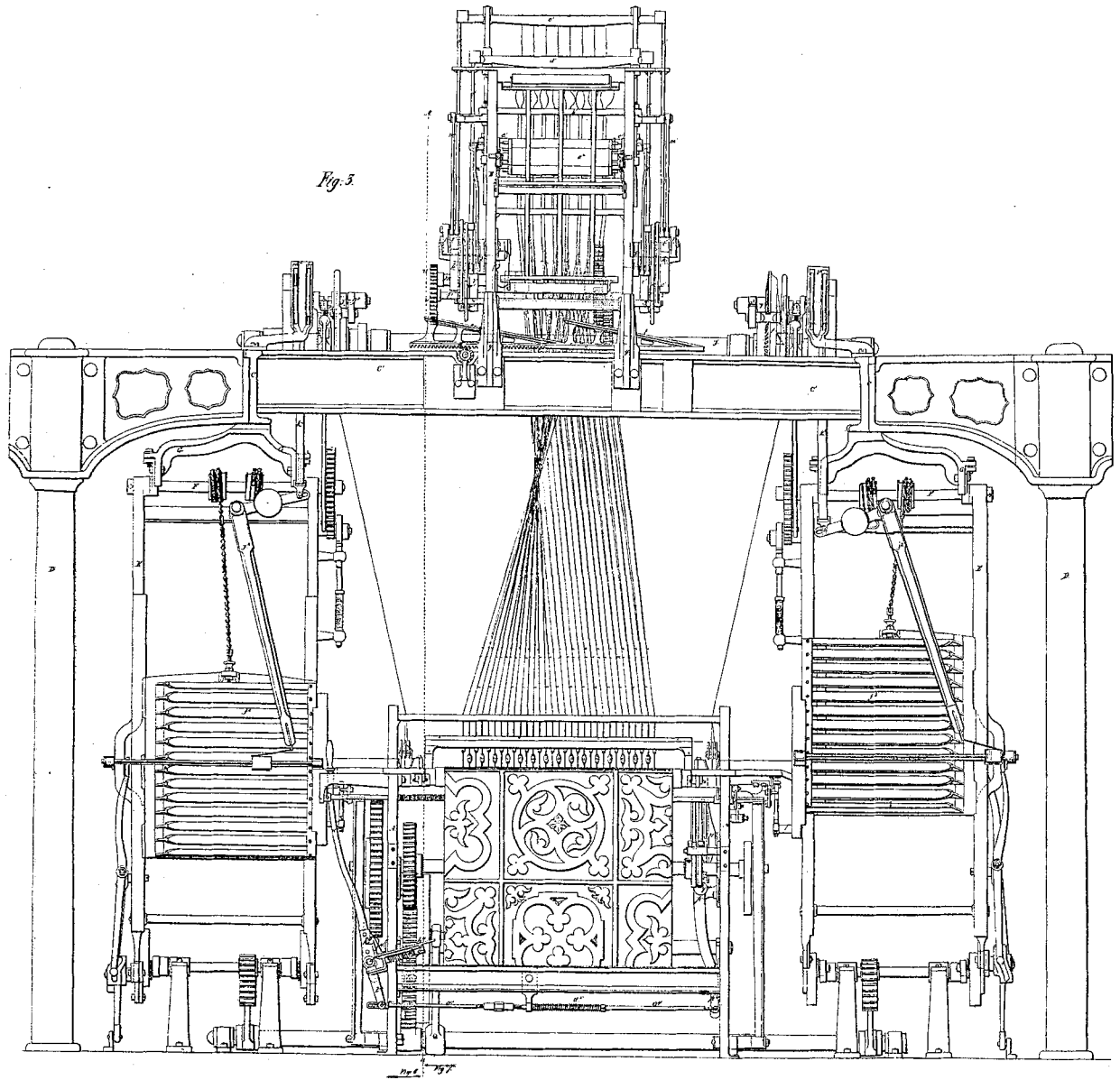

E. S. BIGELOW.

7 Sheets—Sheet 4.

No. 6,806.

CARPET-LOOMS.

Patented Oct. 23, 1849.

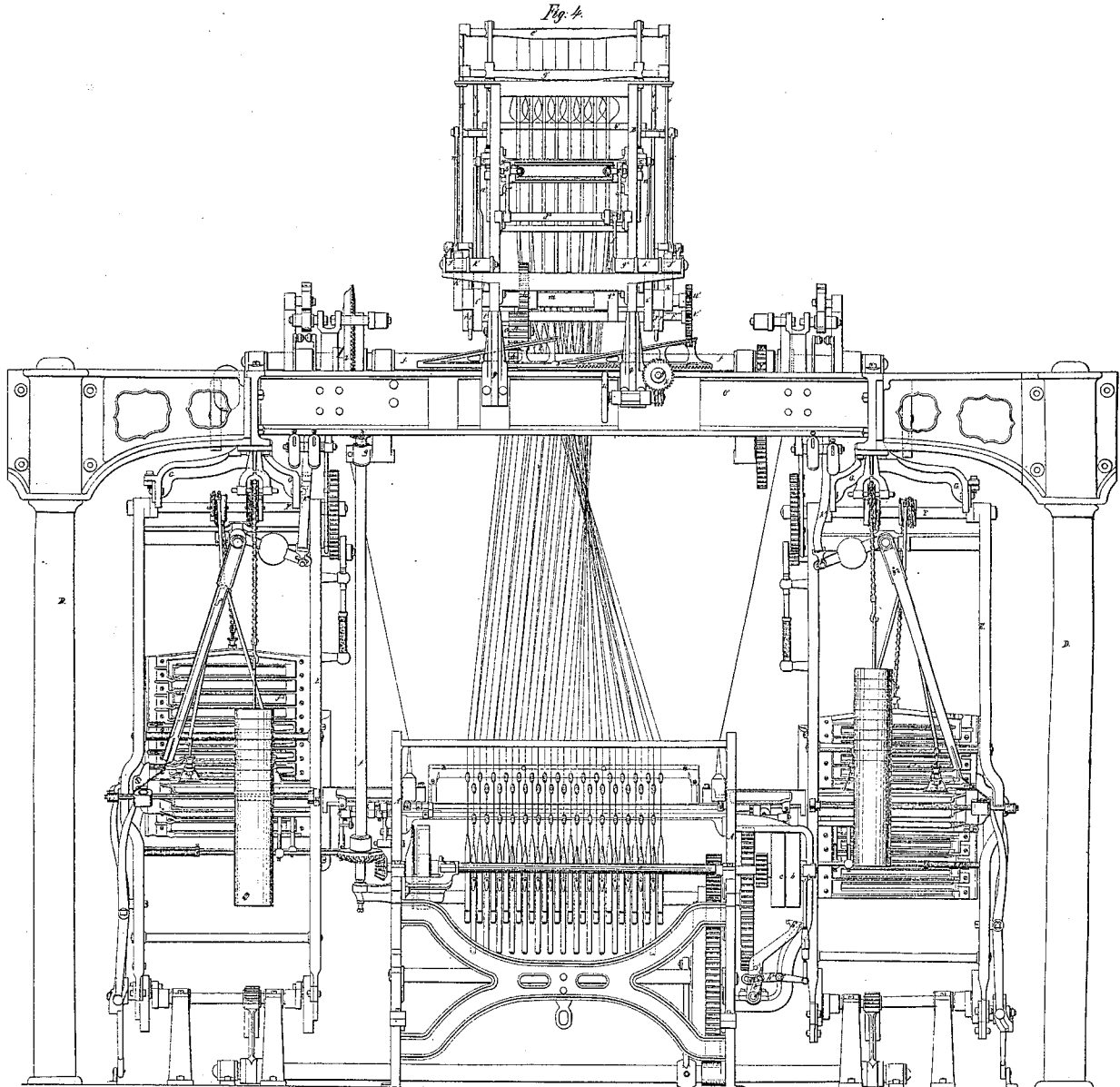

E. B. BIGELOW.

7 Sheets—Sheet 3.

CARPET-LOOMS.

Patented Oct. 23, 1849.

No. 6,806.

Fig. 5.

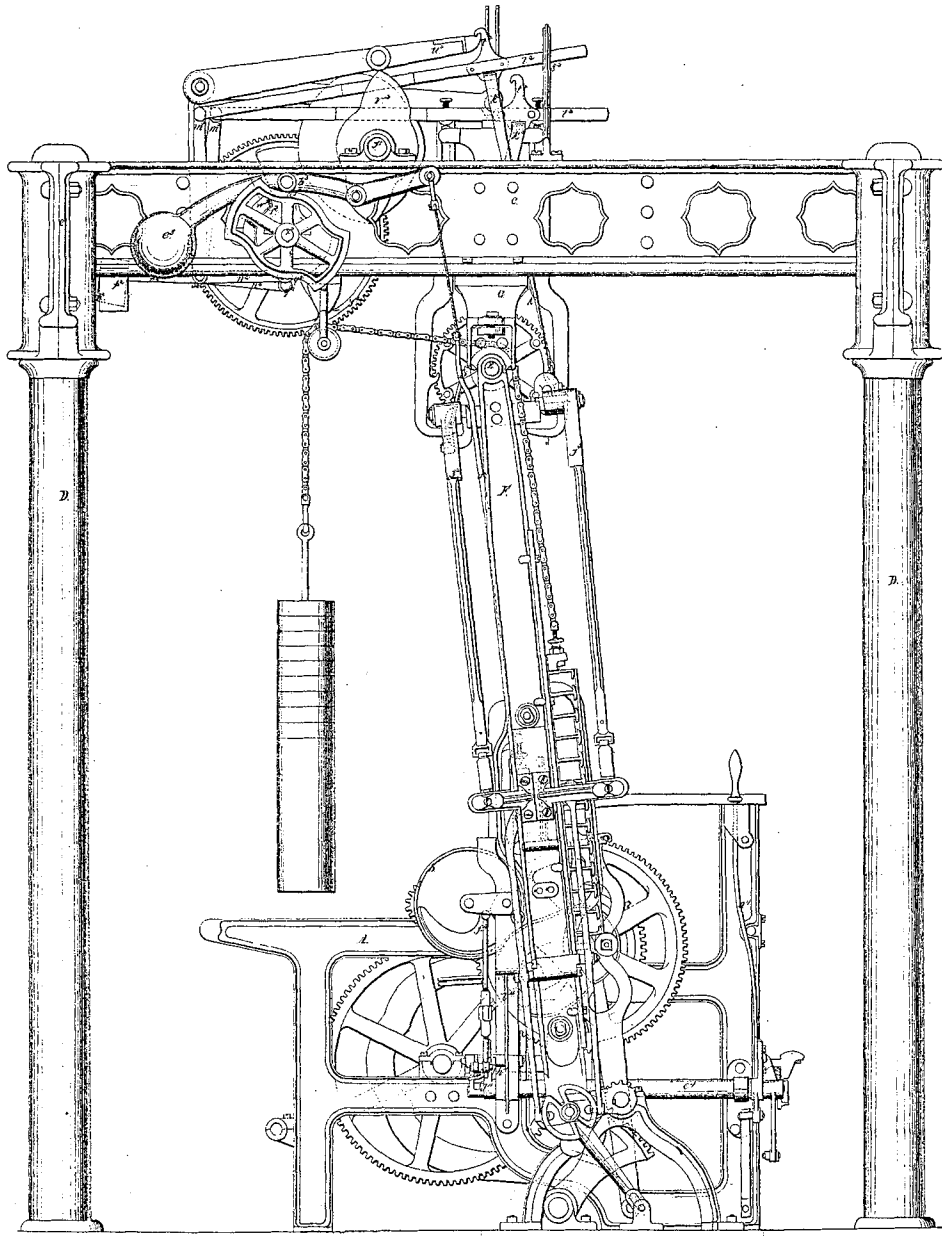

E. B. BIGELOW.

7 Sheets--Sheet 6.

No. 6,806.

CARPET-LOOMS.

Patented Oct. 23, 1849.

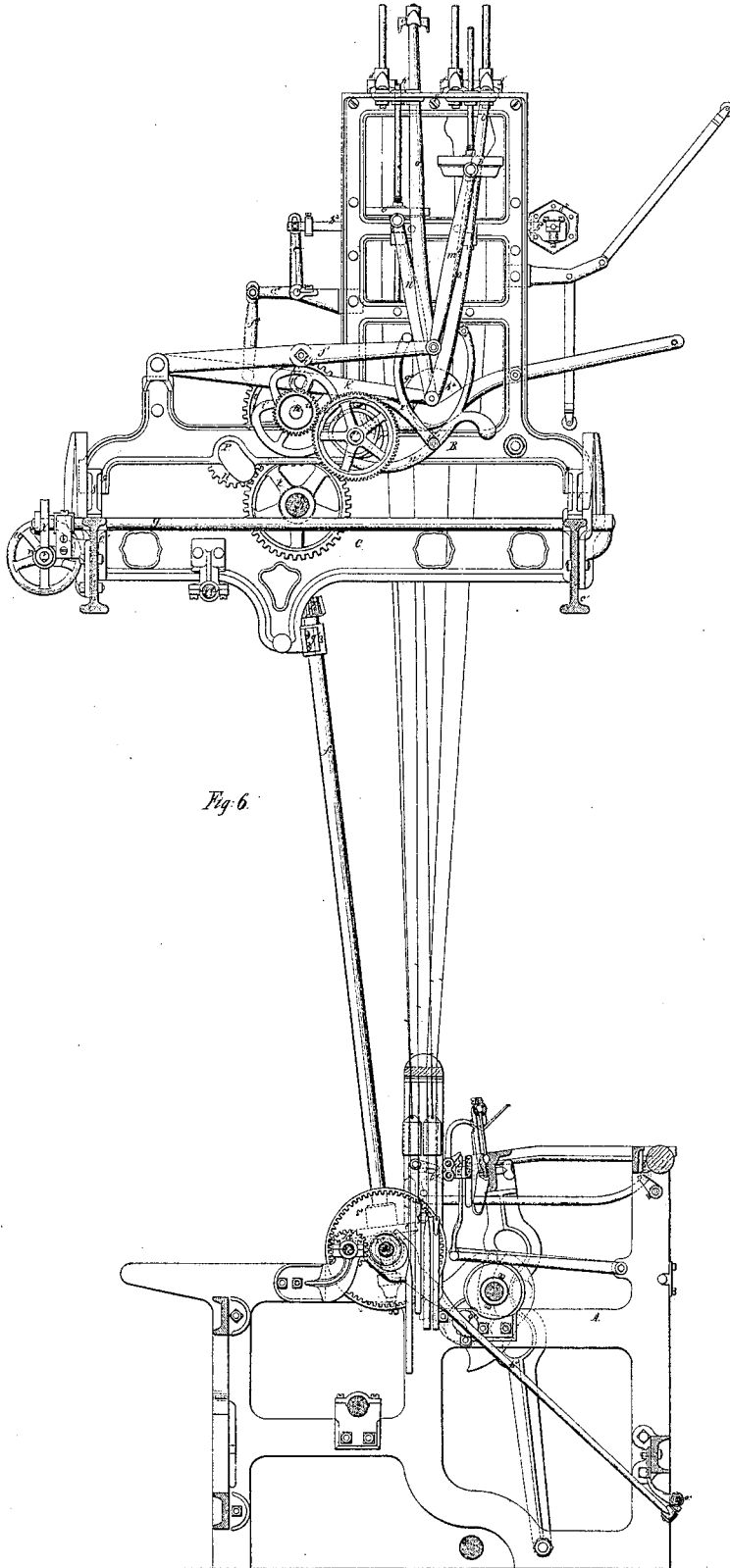

Fig. 6.

E. B. BIGELOW.

7 Sheets--Sheet 7.

CARPET-LOOMS.

Patented Oct. 23, 1849.

No. 6,806.

Fig. 7.

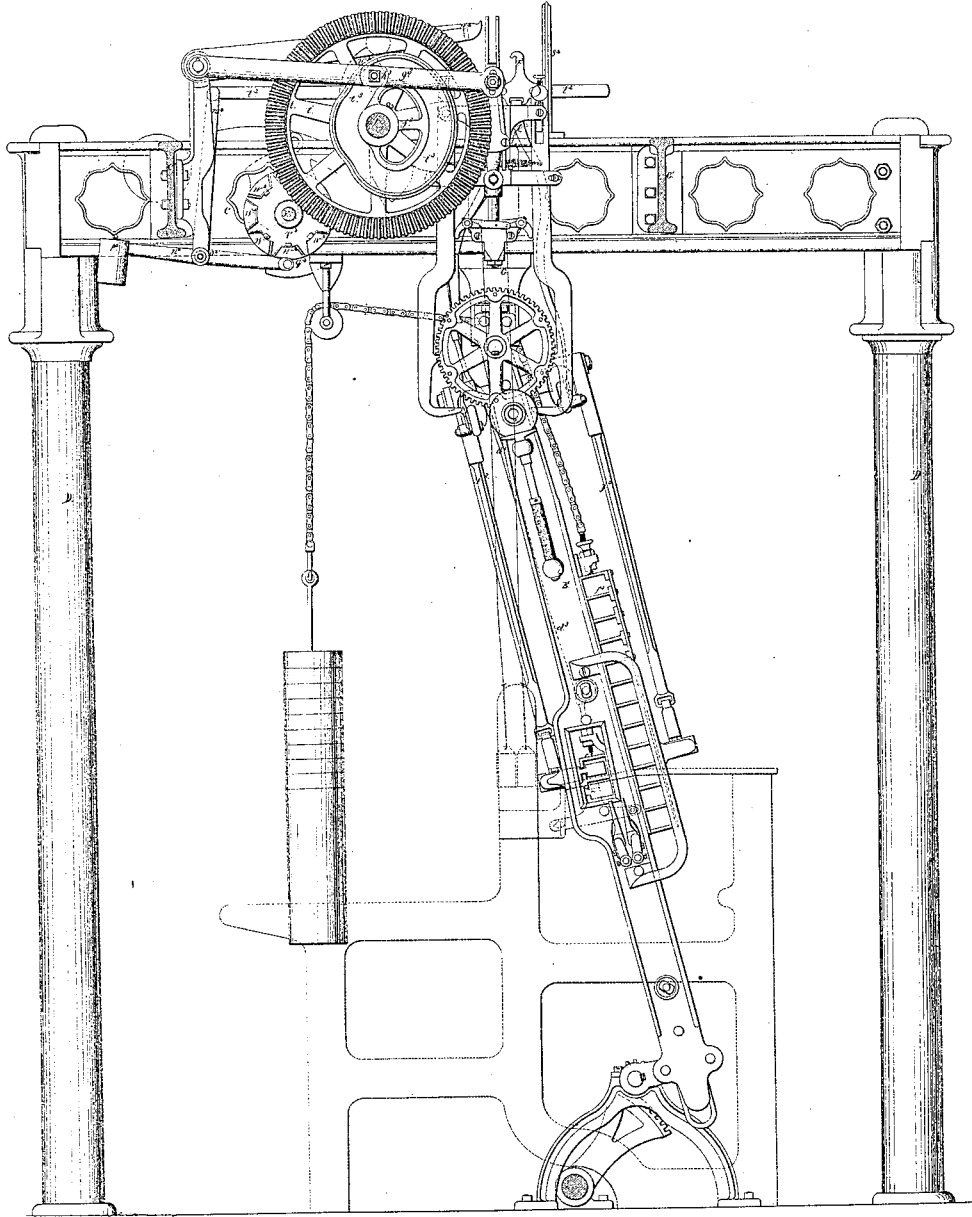

UNITED STATES PATENT OFFICE.

ERASTUS B. BIGELOW, OF CLINTONVILLE, MASSACHUSETTS.

JACQUARD LOOM.

Specification of Letters Patent No. 6,806, dated October 23, 1849.

To all whom it may concern:

Be it known that I, ERASTUS B. BIGELOW, of Clintonville, in the county of Worcester and State of Massachusetts, have invented
5 certain new and useful Improvements in the Power-Loom for Weaving Carpets and other Figured Fabrics, and that the following is a full, clear, and exact description of the principle or character which distinguishes them
10 from all other things before known and of the manner of making, constructing, and using the same, reference being had to the accompanying drawings, making part of this specification, in which—

15 Figure 1, is a plan of a loom on my improved plan; Fig. 2, a plan of the loom below the jacquard; Fig. 3, a front elevation; Fig. 4, a back elevation; Fig. 5, an elevation of the left hand and without the jacquard;
20 Fig. 6, a vertical section with the jacquard taken at the line (A a) of Fig. 3; and Fig. 7, another section taken at the same line of Fig. 4, but looking in the reversed direction of Fig. 6.

25 The same letters indicate like parts in all the figures.

In the accompanying drawings I have represented all the parts of a completely arranged loom with the jacquard arrangement
30 for weaving all kinds of figured ingrain carpets, and applicable to the weaving of other figured fabrics; but as many parts are well known to those acquainted with the art of weaving, and some portions of the principle and arrangement have heretofore been pat-
35 ented by me, the following specification will be limited to the description of the improvements which I now claim, and to the connection of them with what have heretofore
40 been known, so far as it may be necessary to a full, clear, and exact understanding of the principle, construction, and use of my improved loom.

In all looms heretofore used for weaving
45 by power in connection with the jacquard frame, all the motions of the jacquard have been derived directly from some part of the loom and communicated by means of connecting rods, which are necessarily of great
50 length. The leading difficulties attending this mode of communication are inaccuracy in the motions, by reason of the great length of the connections, and their liability to derangement, and the great labor, and difficulty

of adjusting the connections to the varying 55 lengths of the cords of the harness as they are affected by atmospheric changes.

To remedy these evils, the first part of my invention consists in giving to the jacquard a separate organization independent of the
60 loom, that the various motions of the jacquard may be taken from, or given by a shaft or shafts within it, and simply deriving its, or their rotation from some part of the loom, or from some first mover corre-
65 sponding with, or regulated by the motion of the loom or part thereof that the motions of the jacquard may correspond with those of the loom. In this way the motions of the jacquard are rendered more accurate and
70 steady, and the weight of the motive parts is greatly reduced.

The second part of my invention consists in making the whole frame of the jacquard adjustable at one operation relatively to the
75 frame of the loom that the distance between the two may be adjusted to the varying lengths of the cords of the harness, whereby the utmost nicety in the adjustments can be
80 obtained.

The third part of my invention relates to the shuttle motion of looms which have series of shuttle boxes in separate pendulous frames at the sides of the lay, and consists
85 in communicating the required motions to the picker staffs, and to the apparatus for shifting the shuttle boxes, from a shaft or shafts above, whereby I avoid the difficulty of communicating the motions from a shaft
90 or shafts below to the picker staffs and the apparatus for shifting the shuttle boxes which must be attached to, or connected with the shuttle box frames that vibrate on axis
above. And the last part of my invention relates to the introduction in power looms
95 of a reversing motion.

Heretofore the power loom has been provided simply with the means of stopping its motions to enable the attendant to piece the threads, or to do what may be necessary
100 preparatory to restarting; but as the loom cannot always be stopped in the position required, the attendant has to reverse the parts by the application of hand power to the driving pulley, a mode of procedure attended
105 with a waste of time and great inconvenience, for the attendant must leave his usual position to go to the driving pulley,

and in large heavy looms such as are used for weaving carpets, much strength is required to set the parts in motion.

To remedy these defects this part of my invention consists in combining with the power loom a reversing motion whereby after the driving power has been suspended and the moving parts arrested, the attendant may liberate them and reverse their motions.

In the accompanying drawings (A) represents the power loom and (B) the jacquard frame resting on beams (C, C, C' C') supported on columns (D D D D) from the main floor. The pendulous frames (E E) which carry the series of shuttle boxes have their arbors (F F) suspended in hangers (G G) from the beams and these pendulous frames together with the shuttle boxes and their appendages are constructed and operate on the principle and in the manner specified in Letters Patent No. 4696, granted to me and bearing date the 18th day of Feby. 1846.

The driving shaft (a) of the loom has a fast and loose pulley (b, c) on one end which receives the driving belt from any first mover in the usual way; and on the other end the said shaft has a bevel pinion (d) which takes into and drives a bevel wheel (e) on the lower end of a line shaft (f) which extends up to, and has its upper bearing in a box (g) attached to one of the beams (C), the upper end of the said shaft having a bevel pinion (h) which engages and carries a bevel wheel (i) on one end of a horizontal shaft (j) which has its bearings in boxes attached to the tops of the beams (C). It is from this horizontal shaft that all the jacquard and shuttle motions are taken. On this shaft (j) there is a cogged wheel (k) which communicates motion to a cog wheel (l) on the jacquard shaft (m) by the medium of a connecting pinion (n) which turns on a stud pin (o) adjustable in a sector mortise (p), the curve of which is struck from the center of the shaft (m) that the pitch line of the said connecting pinion may be always at the same distance from the axis of the wheel (i) when its stud pin is shifted. By this means when the jacquard frame is adjusted the connecting pinion can also be shifted and adjusted relatively to the pinion (k) on the shaft (j).

The frame (B) of the jacquard, as already intimated, instead of being permanently attached to the beams (C' C') are free to slide vertically for the purpose of vertical adjustment to suit any change in the length of the harness. The side pieces (q q) of the frame of the jacquard embrace the transverse beams (C' C') and slide thereon accurately but freely. The jacquard frame rests on two horizontal slides (S S) which are adapted to slide on

the transverse beams (C' C'), the upper surfaces of each being formed with two inclined planes (t t) one for each of the sides of the jacquard frame to rest on, so that when these two slides are moved so the one side or the other the entire jacquard frame will be elevated or depressed relatively to the loom below, the stud pin of the connecting pinion (n) being at the same time adjusted in its sector mortise to adjust the pitch line of the cogged gearing. The slides (S S) are operated simultaneously by a hand wheel (u) on a short arbor (v) in front which carries a worm (w) that engages the cogs of a wheel (x) on a shaft (y) that carries two pinions (z) (only one shown in the drawings) that engage the cogs of a rack (a') on each of the slides.

For the purpose of adjustment it is only necessary to turn the band wheel until the jacquard is brought to the required position and then to adjust the gearing by shifting the stud pin of the connecting pinion, the thread of the worm on the band wheel arbor, and the inclination of the wedges being sufficient to retain the parts in a permanent position.

The required motions of the trap boards (b') and (c') and the journals (d' e' f' g') are desired from the jacquard shafts (m) which as described above receive a continuous rotary motion from the driving shaft of the loom below, and the proportions of the gearing as represented in the drawing should be such as to give to the jacquard shaft one revolution for every two of the lay shaft of the loom. On each end of the jacquard shaft (m) there are two cams (h' i') and (h' i') which are all of the same form represented in the drawings. The cams (h' h') are placed on opposite ends of the shaft and in corresponding positions to work the trap board (b') and the other two cams (i' i') are arranged in the same manner but on the opposite side of the axis of the shaft (m) to operate the other trap board (c') as one trap board descends as the other ascends; and the form of the cams should be such that one trap board shall begin to ascend as the other begins to descend. There are four levers (j' j' k' k') placed above the cams and operated by them, each lever being hung on a fulcrum pin at the rear of the frame and having a roller (l') which bears on the cam. The two levers (j' j') are connected with the ends of the trap board (b') by connecting rods (m' m') that the cams (h' h') may communicate the required motions to it, and the other levers (k' k') are in the like manner and for the same purpose connected to the other trap board (c') by similar rods (n' n'). In this way it will be perceived that the required alternate up and down motions are given to the two trap boards.

The same cams and levers are employed for operating the four journals (d' e' f' g'). The two journals (d' e') are alternately elevated with the trap board (b') and the other two (f' g') are in like manner with the other trap board (c') which is effected in the following manner. To the ends of the four levers (j' & k') are jointed four rods (o' o' o' o') (one to the end of each) the upper ends of which play in slots (p' p' p' p') in the top plate (q') of the jacquard frame, these slots being of such length that the rods can vibrate sufficiently to pass from one journal to the other. The upper ends of these rods are rounded and enter sockets in the under face of the ends of the journals, so that when brought under either of the journals when the levers are raised by the cams the journals will be elevated. As there are two journals for each trap board, and these are alternately elevated with the corresponding trap board the lifting rods must be alternately shifted from the one to the other. As the rods are so jointed as to incline outward when liberated they will by gravity fall against the outer end of the slots (p') which are so located as to hold the rods in a position to catch under the two outer journals (d') and (g'). In this position when either of the trap boards are elevated one of the journals will be carried up with it, but when the other journals are to be lifted the rods (o') are to be shifted from the outside journals to the inside ones and this is effected by cams (r' r' s' s'), two on each side of the frame, and on one and the same shaft (t') receiving motion from the shaft (m) by two cog wheels (u' v'). These four cams are all of the same form as represented in the drawing and arranged in two sets, one of each set being on each end of the shaft, and the position of the two sets relatively to each other will depend upon the form and position of the levers which they operate.

On each side of the frame there are two levers (w' x') (the two sets corresponding in every particular) that vibrate at (y') on the same arbor, the one (w') bears by the disposition of its weight on the periphery of one of the cams (r') and the other (x') on one of the cams (s'). The other arm of each of these levers acts against one of the rods (o') so that there is one such lever and cam for each rod (o') and as the shaft (t') of these cams makes but one rotation for every two of the jacquard shaft, the levers (w') and (x') will act upon the corresponding rods (o') at every alternate descending motion of each trap board.

The form of the cams (r' s') is such that during one rotation of the jacquard shaft (m) they elevate one set of levers (w' w') to shift the two corresponding rods (o' o') from one journal to the other, and during

the next rotation of the jacquard shaft they recede to permit these rods to fall back, while the other set of levers (x' x') shift the other two rods (o' o') from one to the other of the other set of journals, the next rotation liberating these and shifting the first set. In this way it will be seen that during one operation when the trap board (c') descends the journal (g') descends with it, the trap board (b') at the same time is carried up and with it the journal (e') at the end of this motion the cams (r' r') throw out the levers (w' w') which shift the rods (o' o') to the journal (f')—at the next operation the trap board (c') is elevated and with it the journal (f'), at the same time the trap board (b') descends and with it the journal (e'), and when this has reached the end of its down motion the rods (o' o') continue the motion down sufficiently to clear the sockets of the journals, and then by their own weight the rods fall back to the journal (d') to be ready to carry it up at the next upward motion of the trap board (b') and when this takes place the trap board (c') descends and with it the journal (f') at the end of the down motion of which the rods (o' o') fall to come under the journal (g') so that at the next upward motion of the trap board (c') this journal may be elevated, during which the trap board (b') descends and with it the journal (d') and when this is entirely down the cams (s' s') act upon the levers (x' x') which shift the rods (o' o') to the journal (e'). Thus the journals (d') and (e') are alternately carried up and down with the trap board (b') and the other two journals (f') and (g') with the trap board (c'). The journals of the card prism (a^2) which is of the usual construction are hung in two rods (b^2 b^2) which slide horizontally in the sides of the jacquard frame and which at the back are jointed to two arms (c^2 c^2) in a rock shaft (d^2) from which projects another arm (e^2) connected by a rod (f^2) with a treadle (g^2) that vibrates in a fulcrum pin at the back, its front end being provided with a weight (h^2) of sufficient gravity to push out the prism, the levers being elevated to draw in the prism by a cam (i^2) on the jacquard shaft (m). The form of the cam (i^2) and its position relatively to the trap board cams must be such as to operate the prism during the rest of the trap boards.

Having described the construction and arrangement of parts constituting the jacquard so far as is necessary to a full and clear understanding of what constitutes my invention therein, I will proceed to describe the construction and arrangement of the mechanism for operating the picker staffs (j^2) which are four in number as I employ four series of shuttle boxes, two for each of the shuttle box frames which are arranged on

each side of the loom as described in the Letters Patent granted to me on the 18th day of Feby 1846. The straps (l^2 l^2 l^2 l^2) of the picker staffs extend up to and are secured each to a picker lever (l^2), there being two such levers on each side which are jointed at their back end to the upper arm (m^2) of two levers (n^2 n^2) that vibrate on a stud pin (o^2) attached to one of the beams (C).

The levers (n^2 n^2) constitute each two arms at right angles with the arm (m^2) the back one carrying a weight (p^2) which must be sufficient to carry back the picker lever (l^2) and the forward end carries a roller (q^2) which bears up against the periphery of a cam wheel (r^2) so that when the roller bears on the periphery of this wheel the picker lever is pushed and held forward to the full length of its longitudinal motion, but when, by the rotation of the wheel, the roller is permitted to enter a depression in its periphery, the picker lever is drawn back. As stated above and as represented in the drawings there are two picker levers on each side, one for each picker staff and therefor two inverted T levers (m^2 n^2) and one cam wheel (r^2) for each lever (m^2 n^2). The forward end of the picker levers (l^2) work between vertical guides (s^2) to prevent lateral play and they are each provided with a hook (t^2) which when the lever is drawn back hooks into the end of the picker treadle (u^2) which is made of sufficient breadth to receive and operate the two, there being one treadle on each side and operated at the proper periods of time by two cams (v^2 v^2) one for each treadle and placed on opposite ends of the shaft (j) before described. Each cam has two projections opposite to each other so as to operate the treadle twice for each rotation and the projections of the two cams are placed in the same line so that the two treadles are operated at the same time and the shaft makes one rotation for every two beats of the lay of the loom, hence the treadles are both worked once for each beat. This simultaneous working of the treadles is rendered necessary because two shuttles have frequently to be thrown in succession from the same side, as both treadles are operated for each beat of the lay and there are two picker staffs on each side, at each beat of the lay one of the picker levers (l^2) must be put in connection with one of the treadles while the other remains disconnected. This is effected by drawing back the picker lever which is to be operated until its hook catches into one of the treadles, and this must be done while the treadle is down and at rest. The manner in which the picker treadles are drawn back to effect the hooking onto the treadle has already been described, as also the man-

ner of pushing them forward to carry their hooks beyond the range of motion of the treadles, and it only remains to explain how the succession is determined. This is done by means of four cam wheels (r^2), (the four are seen in Fig. 2) which act on the four levers (n^2 m^2) as described above. These cam wheels are formed with a series of cam like depressions (w^2) made at equal distances around the periphery, into each of which the roller of the levers (n^2) enter, and when this takes place the weights on the levers (n^2) draw the picker levers so far back that the treadles in rising catch under the hooks and elevate the picker levers, and the further rotation forces out the rollers from the cam like depressions into the periphery of the circle of the wheels which forces the picker levers so far forward as to disengage the hooks.

There must be as many of these cam like depressions in each cam wheel as the number of changes of shuttle required in the kind of fabric to be woven, eight being the number represented in the drawings for eight changes of shuttles. To each of these depressions is fitted a block, which, when put in, forms the periphery of the wheel cylindrical; and when all are in, the picker levers will not be engaged or hooked by the treadle and hence no shuttle will be thrown and therefore in setting the loom for any particular kind of fabric the operator will leave out of each of the cam wheels as many of these blocks, and in the order required as may be necessary for operating the picker staffs in the order required for the succession of the shuttles.

The four cam wheels (r^2) are on a shaft (x^2) parallel with, and receiving motion from the shaft (j) by a cog wheel and pinion (y^2 z^2) the shaft (x^2) making one rotation for four of the shaft (j).

There are two cams (a^3 a^3), one at each end of the shaft (x^2), which cams operate two levers (b^3 b^3) and these levers are connected each with one of the back series of shuttle boxes (c^3 c^3) by means of connecting rods (d^3 d^3), the other end of these levers being provided with weights (e^3 e^3) of sufficient gravity to lift the shuttle boxes. The form of these cams and the periods of their action on the levers to operate the back series of shuttle boxes are essentially on the principle described in the Letters Patent granted to me bearing date the 18th day of February 1846, before referred to, except that the cams are placed on a shaft above instead of below, by which variation I attain the advantages above pointed out. This being the only variation in this part of my invention from my before recited Letters Patent, I deem it unnecessary to describe the details of the construction and arrangement as these will be found set forth in the said

(s⁴) so that the motion of the loose pulley communicates a reversed motion to this wheel which drives the main shaft in the reversed direction whenever they are locked together by the friction plate. The moment that the attendant removes his foot from the treadle the wheel is withdrawn from the friction plate by the tension of a helical spring (a⁵) on the slide rod (o⁴) and the parts are then in a condition for starting the loom by the shifting of the belt onto the fast pulley.

I have thus specified the principle or characteristics which distinguishes my invention from all other things before known together with the construction and arrangement which I have essayed and deem best adapted to the successful application of my principle to use. I do not however wish to confine myself to this special construction and arrangement as it is susceptible of many modifications, all involving and partaking of the essence of my invention; as for instance, the jacquard motion may be given in any manner desired from one or more shafts, so long as the jacquard has a separate organization from the power loom, the motions therefor being taken from a shaft or shafts making part of the jacquard but deriving motion from the loom or from some first mover governed by or working in unison with the loom. The means employed for adjusting the jacquard frame relatively to the loom may be variously modified within the range of this part of my invention, as for instance, scroll wheels on two parallel shafts geared together, or a series of screws geared together may be substituted, in short any known equivalent means of elevating or depressing the jacquard frame equally and from any one point may be substituted for the one described and represented.

The motions for the picker staffs and for communicating the required motions to the apparatus for shifting the series of shuttle-boxes may be various; and I do not therefore wish to limit myself to the employment of any particular mechanical movement or movements as this part of my invention consists in simply taking these various motions from a shaft or shafts above instead of below and therefore it will be obvious that the motions themselves or the mechanical arrangements may be various so long as they are taken from a shaft or shafts above. And finally as to the reversing motion of the loom I have described an arrangement of mechanical means for applying this part of my invention, but as the principle like all other general mechanical principles, is susceptible of numerous modifications I do not wish to confine my claim to the special combination and arrangement described, but to cover all which are essentially the same for reversing the motion of the moving parts after the

belt has been shifted and the momentum of the moving parts have been arrested.

What I claim as my invention therefore and desire to secure by Letters Patent is—

1. Giving to the jacquard frame of jacquard looms working by power, a separate organization, that is giving the various motions of the jacquard by a shaft or shafts within or making part of the jacquard in contradistinction to the weaving loom, but receiving motion from the loom or frame, some first mover governed by, or working in unison with the loom, substantially as described, and for the purpose specified.

2. I claim the method of adjusting the jacquard frame relatively to the weaving loom substantially as described so that the attendant can from a given point make the adjustment to suit the condition of the harness as described.

3. I claim taking the motions for operating the picker staffs and the apparatus for shifting the shuttle boxes from a shaft or shafts placed above and in combination with the pendulous frames which carry the shuttle boxes, substantially in the manner, and for the purpose specified.

4. And lastly I claim in combination with the power loom a reversing motion substantially as described, so that after the driving power has been removed and the momentum of the moving parts arrested, the attendant may set in motion the reversing motion and drive the loom in the reverse direction to bring the parts to the position required for restarting, substantially described.

E. B. BIGELOW.

Witnesses:

JAMES STEWART,
CHAS. STEVENS.

Disclaimer.

To all whom it may concern:

Be it known, that whereas on the 23rd day of October, A. D. 1849, Letters Patent of the United States for Improvements in Jacquard Looms, were granted unto me, and whereas I then believed and do still believe that I am the original and first inventor of all the improvements recited in the specifications of claim in the said Letters Patent; and whereas for more than two years prior to my application for the Letters Patent aforesaid, certain reversing motions or apparatus of my invention were with my consent and allowance in use in power looms in the city of Lowell in the State of Massachusetts; and whereas I, ERASTUS B. BIGELOW, the patentee named in the Letters Patent aforesaid, have been lately informed by compe-

Letters Patent. And as to the front series of shuttle boxes ($f^3 f^3$) they are constructed and arranged, as also the apparatus for shifting them, in the same manner as in the before mentioned Letters Patent, but instead of working the shifting apparatus by cams on a shaft below I operate them by levers ($g^3 g^3$) which have rollers ($h^3 h^3$) working in cam grooves ($i^3 i^3$) in cam wheels ($j^3 j^3$) on the shaft (j) which carries the cams for operating the shuttle staffs, the form of these cam grooves and the connections of the levers with the shifting apparatus being on the principle of, and arranged in the manner substantially similar to that described in my before recited Letters Patent to which reference is made. Having described my improvements in connection with the working of the shuttles and shuttle boxes, I will proceed to describe my improvements in the method of stopping and reversing the motions of the loom. The belt is shifted from the loose to the fast pulley, and vice versa, by the belt shipper (a^4) and belt guide (b^4) in the usual way, but to adapt this to the introduction of a reversing motion the shipper and the guide are differently arranged.

The shipper (a^4) and the belt guide are on opposite ends of a shaft (c^4) hung in appropriate boxes, and this shaft is hollow and within it there is an arbor (d^4) which extends out at each end. From the rear end of this inner arbor projects an arm (e^4) which carries a wrist pin (f^4) that fits and slides freely, but accurately in a curved mortise (g^4) in one arm of a lever (h^4) that turns on a fulcrum pin (i^4), its other arm being jointed to the connecting rod of the brake (j^4) that works against the inner periphery of the fast pulley (b) in the usual way of arranging the brake for arresting the operations of a loom when the belt is shipped from the fast to the loose pulley. When the inner arbor (d^4) is therefore connected with the shaft of the shipper, the brake is operated to make friction on the fast pulley, when the belt is shifted to the loose pulley, and liberated to relieve the friction when the belt is shifted to the fast pulley, the motion of the shipper to shift the belt from the one to the other of the pulleys being sufficient to move the arm (e^4) so that its wrist (f^4) shall move over a distance equal to half the length of the curved mortise in the lever of the brakes—the curve and the length of this mortise being such that in moving the wrist pin from either end of the mortise to the middle will force the brake against the pulley to make friction, and from the middle toward either end will remove the brake. As I employ the loose pulley for the purpose of giving the reverse motion it becomes necessary in the first place to stop the loom, and then to start it in the

reverse direction, and therefore in shifting the belt from the fast to the loose pulley the brake at first must be operated to make friction to arrest the parts, and then liberated while the mechanism of the reversing motion is brought into action. This I effect in the following manner. On the front end of the arbor (d^4), where it projects beyond the hollow shipper shaft, there is an arm (g^4) which projects out toward the middle of the loom nearly in a horizontal direction and at a convenient height to be reached by the attendant's foot. On this arm is journaled a treadle (h^4) and so connected with the arm (g^4) by means of a helical spring (i^4) that when no force is applied to it, one arm (j^4) which projects upward from its inner end is held against a projection (k^4) of the shipper so that the arbor of the brake and the shaft of the shipper are kept in a locked condition by the helical spring (i^4) to be operated together, but when pressure is applied on the top of the treadle then the brake is operated separately to remove the friction from the pulley.

When the attendant moves the shipper toward him the belt is shifted from the fast to the loose pulley, the brake at the same time being drawn down to make friction for arresting the momentum of the moving parts and then the attendant with his foot forces down the treadle which relieves the brake which liberates the parts preparatory to the reversing motion which is brought into action by the same motion. From the bottom of the treadle projects an arm (l^4) that carries a pin (m^4) that plays freely in a mortise (n^4) in the end of a sliding rod (o^4) and the length of this mortise is such that the motions given to the arm (l^4), by the ordinary motions of the shipper, will not communicate motion to the sliding rod, but when the treadle is borne down to relieve the brake after the shifting of the belt into the loose pulley, the sliding rod is drawn down in the direction of the arrow.

The sliding rod (o^4) is jointed to the lower arm of a lever (p^4) which turns on a fulcrum pin (q^4), its upper arm being forked and made to embrace the collar (r^4) of a wheel (s^4) which slides freely on the main driving shaft (a) of the loom. When the sliding rod (o^4) is drawn in the direction of the arrow it forces the wheel (s^4) against the face of a friction plate (w^4) which is fast on the main shaft, and this friction plate has the effect to lock it with the main shaft so that any motion given to this wheel (s^4) will drive the main shaft.

The hub (v^4) of the loose pulley carries a pinion (w^4) which engages another pinion (x^4) on a parallel shaft (y^4) the other end of which has a pinion (z^4) which engages cogs on the inner periphery of the wheel

70

75

80

85

90

95

100

105

110

115

120

125

130

tent legal authority, who have at my request examined the aforesaid patent, that the last clause of the specification of claim taken in connection with the schedule and description, would cause such specification to be so construed too broadly, so as to hold as infringers of that patent parties making or using a reversing motion or reversing apparatus like that used at Lowell aforesaid more than two years prior to my application for the aforesaid patent.

And whereas I have also been lately informed by the authority aforesaid, that the use at Lowell aforesaid would be considered, treated and held by the courts of the United States as a public use, and that therefore my last specification of claim in the aforesaid patent covers more than is truly and justly my own by virtue of said Letters Patent.

And whereas the reversing motion specially described in the aforesaid patent operates by the use of the same belt that drives the loom ahead thus working the loom ahead and backward by a single belt, and also operates to reverse the loom by the use of a friction clutch, [called in the patent a "wheel" and "friction plate"] which starts the loom gradually from a state of rest, thereby avoiding wear and tear, and breakage of parts, and also lifts or raises the brake so that it shall not impede the loom while moving backward; and whereas none of such features existed in my reversing motion used at Lowell as aforesaid more than two years prior to my application for the same.

And whereas I, the aforesaid E. B. BIGELOW, am the sole owner of the patent aforesaid.

Now, therefore, I do publish and declare that the aforesaid last clause of specification of claim is hereafter to cover and hold and to be construed as a claim, only to reversing motions which operate substantially as described in the patent aforesaid, by the use of a single belt both for reversing and driving the loom ahead, or by the use of a friction clutch by means of which the loom is started gradually from a state of rest to acquire its reversing motion, or by the use of a contrivance which relieves the loom from the action of the brake while it is being run backward, substantially in the manner described in the aforesaid patent; and I do further declare that I will not hereafter claim or hold by virtue of said patent, or treat, or complain of, as infringers thereof, manufacturers or users of a reversing motion like that used at Lowell aforesaid, more than two years prior to my application aforesaid, and not working by the use of a single belt, or a friction clutch, or by a lifting of the brake when the loom is moving backward, substantially as set forth in the aforesaid patent.

And this my disclaimer is to operate to the whole extent of the patent aforesaid.

Boston, 11th Sept., 1863.

E. B. BIGELOW.

Witness:

N. JULIUS PARKS.