

P. GREENWOOD.
LACE MAKING MACHINE.
APPLICATION FILED JAN. 8, 1917.

1,351,329.

Patented Aug. 31, 1920.
3 SHEETS—SHEET 1.

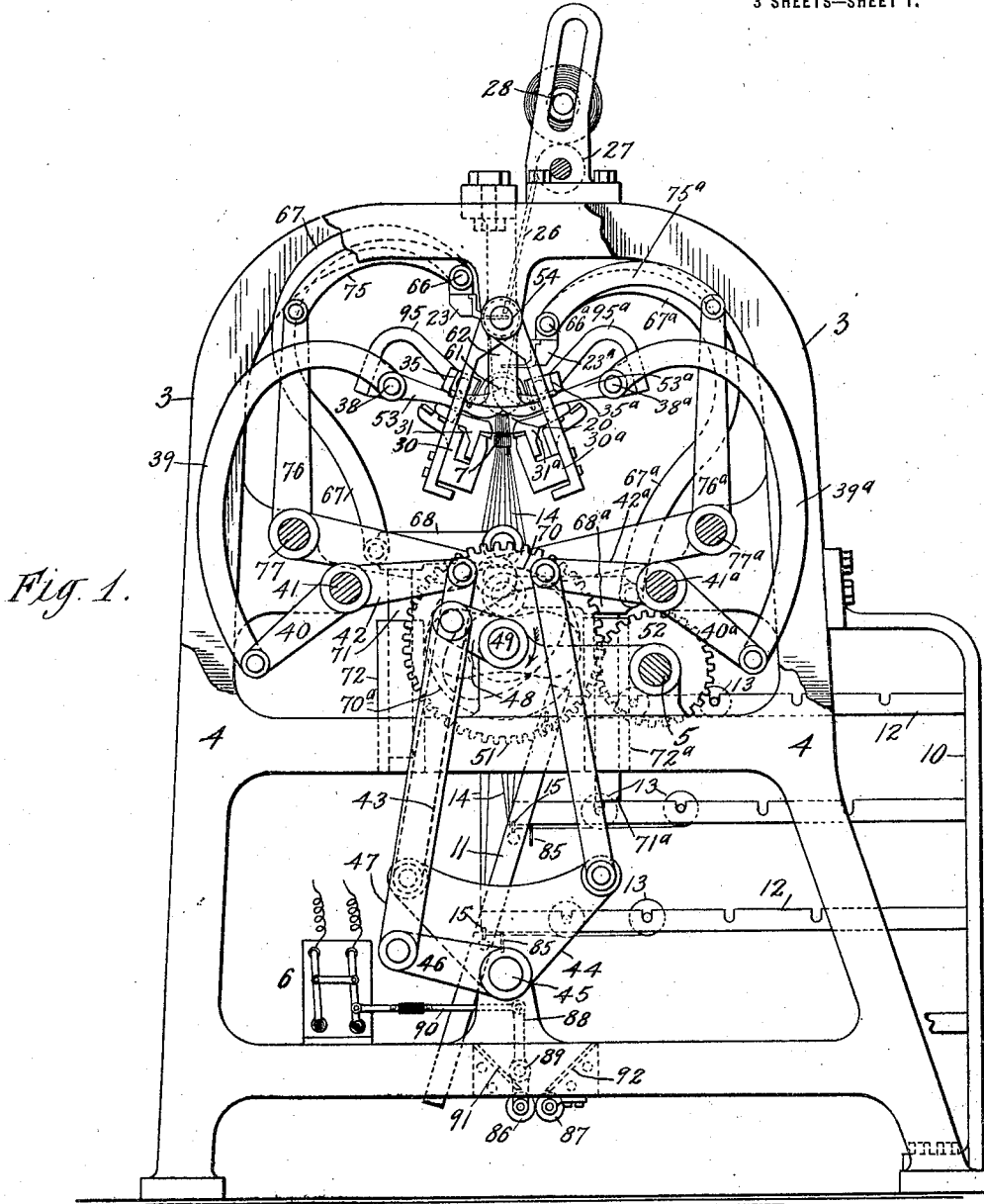

Fig. 1.

Inventor:
Percy Greenwood
by his Attys
Philip Augustus Rice Kennedy

P. GREENWOOD.
 LACE MAKING MACHINE.
 APPLICATION FILED JAN. 8, 1917.

1,351,329.

Patented Aug. 31, 1920.

3 SHEETS—SHEET 2.

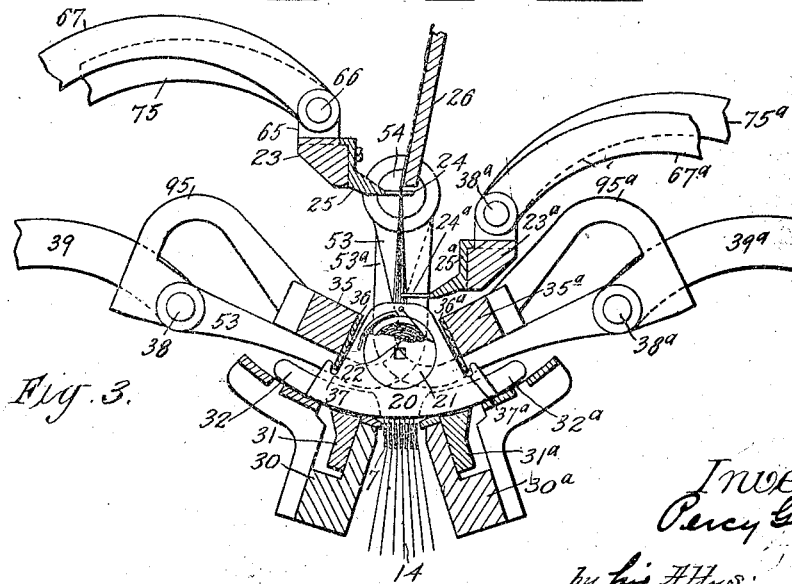
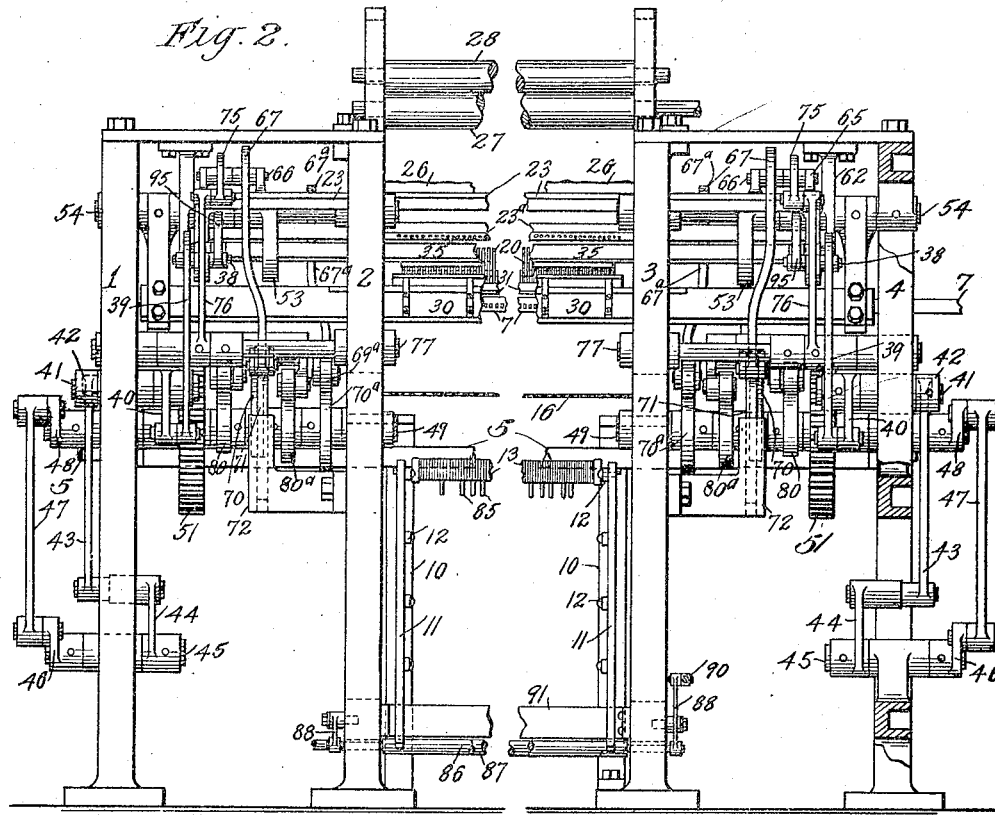

Inventor:
 Percy Greenwood
 by his Attys:
 Philipp Dunper Reis & Kennedy

P. GREENWOOD.
 LACE MAKING MACHINE.
 APPLICATION FILED JAN. 8, 1917.

1,351,329.

Patented Aug. 31, 1920.
 3 SHEETS—SHEET 3.

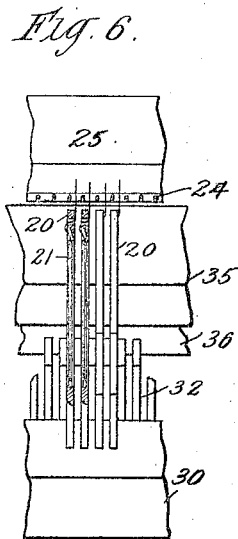
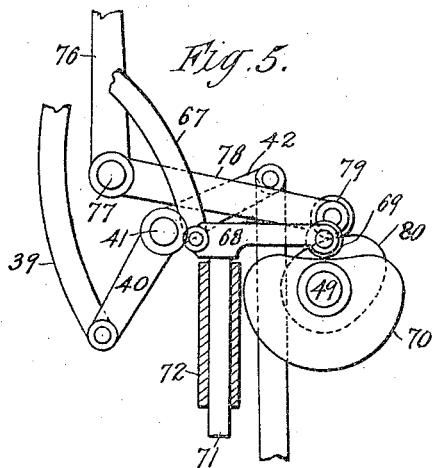
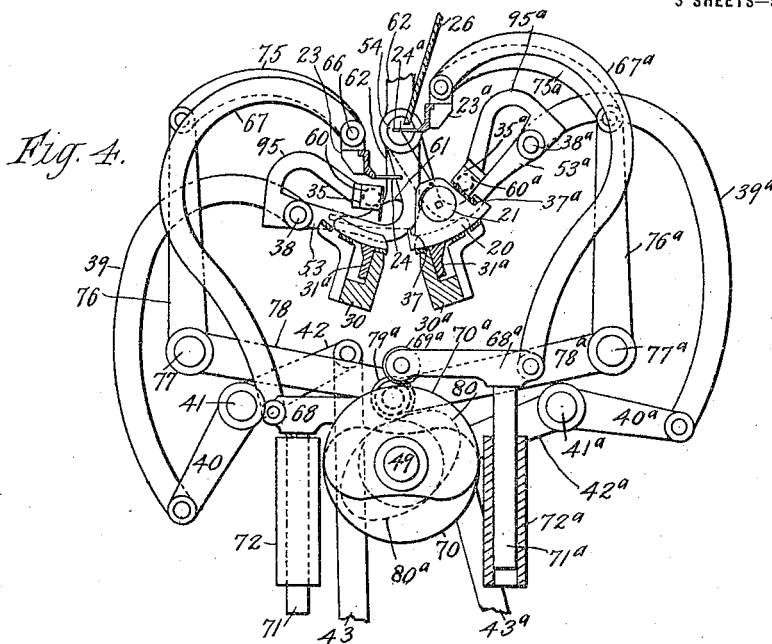

Inventor
Percy Greenwood
 by his Attys:
Philip Danvers Rice & Kennedy

UNITED STATES PATENT OFFICE.

PERCY GREENWOOD, OF NEW YORK, N. Y., ASSIGNOR TO AUGUST A. FOLLMER, OF
NEW YORK, N. Y.

LACE-MAKING MACHINE.

1,351,329.

Specification of Letters Patent. Patented Aug. 31, 1920.

Application filed January 8, 1917. Serial No. 141,115.

To all whom it may concern:

Be it known that I, PERCY GREENWOOD, a subject of the King of Great Britain and Ireland, residing at New York city, borough of Bronx, county of Bronx, and State of New York, have invented certain new and useful Improvements in Lace-Making Machines, fully described and represented in the following specification and the accompanying drawings, forming a part of the same.

This invention relates to improvements in lace making machines. The primary object of the invention is to provide a machine which will be much smaller in size, much more compact and much more easily accessible for inspection, repairs and adjustment in use, and which, at the same time, will be equal in capacity of lace production to machines heretofore in use having the same equipment, in number and size, of lace forming devices. This object is attained by a novel arrangement, relatively to each other, of the lace forming devices and the operating devices therefor. This novel arrangement results, not only in the utilization of space within the machine which has heretofore been wasted, but also in removing the obstacles heretofore present in lace making machines to inspection, repair and adjustment of the machine or of the lace threads therein. The removal of these obstacles by the present invention greatly facilitates such inspection, repairs and adjustment, which furthermore may be performed with safety while the machine is running. A further advantage of the novel arrangement referred to is a substantial decrease in the cost of building lace-making machines. Another object of the invention is to provide a safety device for automatically stopping the operation of the machine on the breaking of a thread, so as to avoid the production of defective lace.

Figure 1 is a side elevation of a lace making machine constructed in accordance with the present invention.

Fig. 2 is a front elevation of the same partly broken away in the middle.

Fig. 3 is a vertical sectional view on enlarged scale, and partly, in section, of certain of the lace forming devices.

Figs. 4 and 5 are similar views illustrating the parts in different positions, and

Fig. 6 is a detail, in front elevation, on an enlarged scale, of certain of the devices shown in Figs. 1 to 3.

Referring to said drawings, 1, 2, indicate standards constituting the frame work for the right-hand side of the machine, while 3, 4, indicate standards constituting the framework for the left-hand side, these various standards being suitably connected and supported. Mounted in this frame work is the driving shaft 5 which extends across the machine from standard 1 to standard 4 and is driven from any suitable source of power, as, for example, an electric motor (not shown) the circuit to which is controlled by a switch 6.

The lace making machine shown has combined with it a jacquard mechanism (not shown) which operates, in the usual way, jacquard bars 7 suitably mounted in the standards 1, 2, 3, 4, for endwise movement in a horizontal direction across the middle of the machine between standards 2, 3. In this middle portion of the machine an open lace-making space is provided through which the lace forming threads pass and at the upper end of which the lace-forming devices operate upon them to form the lace, as shown later on.

Mounted in standards 10, 11 are notched racks 12 for supporting the spools 13 which supply the warp threads 14 to the lace forming devices. These threads 14, on leaving the spools 13, pass through eyes 15 in the standards 11, thence upwardly through a slay 16 and finally through eyes in the jacquard bars 7 and to other lace forming devices above them. These other lace forming devices comprise the usual bobbin carriages 20 carrying bobbins 21 containing the locking threads 22 for the lace, and also front and rear point bars 23, 23^a having the usual points 24, 24^a for engaging these threads as laid and moving them upwardly into proper relation to each other to complete the lace. The points 24, 24^a, are formed or mounted in blocks 25, 25^a, secured along the bars 23, 23^a. The lace as formed passes upwardly over a face bar 26 to wind up rolls 27, 28, which wind up the lace as completed and at the same time draw

the lace forming threads upwardly through the machine.

The bobbin carriages 20 are mounted on an arc shaped frame 30, which supports the comb bar 31 carrying the combs 32 between the teeth of which the bobbin carriages 20 reciprocate back and forth, between the front and rear of the machine and, as they thus reciprocate, position the locking threads 22 with relation to the warp threads 14. The bobbin carriages 20 are thus reciprocated by a pair of opposed catch bars 35, 35^a, at the front and rear, respectively, of the machine. These catch bars are provided with catch plates 36, 36^a engaging slots 37, 37^a in the ends of the bobbin carriages. The means for operating the front and rear catch bars 35, 35^a are identical. Those for the front catch bar 35 will only be described in detail, like reference numerals, followed by the letter "a" being applied to like operating parts for catch bar 35^a. Catch bar 35 is loosely hung, by an arm 95, on a pivot 38 in one end of a link 39 the other end of which is connected to an arm 40 fixed on a rock shaft 41, this rock shaft also carrying an arm 42 which in turn is connected by a link 43 to a rocker arm 44 mounted on a rock shaft 45. The latter has secured to it an arm 46 to which is pivoted one end of a link 47 the other end of which is pivoted to a crank arm 48 fixed to a shaft 49 which is rotated in the direction of the arrow Fig. 1, by gears 51 fixed to it and meshing with pinions 52 (one of which is shown in Fig. 1) secured to the driving shaft 5. The pivot 38 for catch bar 35 has also loosely connected with it one end of an L-shaped lever 53, the other end of which is loosely hung or pivoted on a shaft 54 near the upper end of the machine, so that said lever is free to swing on said shaft in an arc coincident with the upper surface of bobbin carriage guiding frame 30.

As the parts are shown in Figs. 1 and 3 the bobbin carriages 20 are in their mid position, to which they have been moved from the front of the machine by catch bar 35, and are about to continue their movement toward the rear of the machine. Their continued movement in this direction is effected by catch bar 35^a, as shown later on. In this mid-position of the bobbin carriages the rocker 44 occupies the position in which it is shown in Fig. 1, with both catch bars 35, 35^a engaged with the bobbin carriages. Further rotation of shaft 49 in the direction indicated by the arrow in Fig. 1, moves rocker 44 upwardly at the left and downwardly at the right, thereby raising the link 43 at the left and correspondingly lowering the link 43^a at the right. As the former is raised it will, through arm 43, arm 42, rock shaft 41 and arm 40, move the arm 39 downwardly, as shown in Fig. 4. While the arm

39 is being so moved the arm 53 will, by reason of its pivotal connection at 52 with the frame of the machine, move the pivot 38 of the arm 39 rearwardly, and therefore move the catch bar 35 rearwardly. As the catch bar 35 is thus moved a bowl 60 carried thereby will engage a stationary cam 61 mounted on a bracket 62 fixed to the frame of the machine, which cam will then raise the catch bar 35 so as to disengage its catch plate 36 from the bobbin carriages. While this is taking place the link 43^a is, as before stated, moving downwardly and, in doing so, will, through arm 42^a, rock shaft 41^a, and arm 40^a, move the arm 39^a upwardly to the position shown in Fig. 4. As the arm 39^a is thus moved upwardly the catch bar 35^a, the catch plate 36^a whereof is retained by gravity in engagement with the slots 37^a in the bobbin carriages 20, will move the bobbin carriages rearward. As the rotation of the shaft 49 continues and the rocker 44 is therefore rocked in the opposite direction to that just stated the bobbin carriages 20 will be moved by the catch bar 35^a in the opposite direction, that is toward the front of the machine, until the bobbin carriages have reached their mid-position (Fig. 3) when the catch bar 35 will ride off the cam 61 into reengagement with the slots 37 in the bobbin carriages 20 and catch bar 35^a will be withdrawn, by the engagement of cam 61^a with bowl 60^a, from engagement with the slots 37^a in the bobbin carriages; the movement of the carriage to the front of the machine being thereafter completed by the catch bar 35. It will thus be observed that the catch bar 35 moves the bobbin carriages 20 from the front of the machine to the middle thereof; that it is then disengaged by cam 61 from the bobbin carriages; that the rearward movement of the carriages is then completed by catch bar 35^a; which meanwhile has dropped off its cam 61^a into engagement with the carriages, that the catch bar 35^a then moves the carriages from the rear to the middle of the machine; where the catch bar 35^a is disengaged from the carriages by cam 61^a, and that the catch bar 35^a then reengaging the carriages moves them toward the front of the machine and then back to their mid-position; and so on.

The operation of the point bars 23, 23^a is effected at the proper time with reference to the reciprocations of the bobbin carriages 20 by double sets of cams for the right and left sides of the machine. As the two sets of cams and parts operated thereby for both ends of the machine are alike, only one set of such devices need be described in detail, like reference numerals being applied to the other set. It should also be noted that as the two front and rear point bars 23, 23^a, with their cam and other operating connections, at each end of the machine are identi-

cal, only one, with its cam and other operating connections, need be specifically described, the same reference numerals being applied to both, followed, in one case, by the reference letter "a". Selecting, therefore, the front point bar 23 it will be observed that it is fixed by brackets 65 and studs 66 to one end of a link 67 the opposite end of which is pivoted to an arm 68 which carries a bowl 69 resting upon a cam 70 fixed to shaft 49. The arm 68 carries a depending guide bar 71 sliding in a guiding bracket 72 secured to the frame of the machine, as shown in Figs. 1 and 2. The function of the cam 70, as hereinafter more fully pointed out, is to raise and lower the point bar 23. The point bar 23 is also pivotally mounted in one end of a link 75, the other end of which is pivotally connected with an arm 76 fast to a rock shaft 77 journaled in the machine frame and to which is secured one end of an arm 78, the opposite end of which has a bowl 79 engaged by a cam 80 fixed to the shaft 49. The functions of this cam, as will presently be more fully stated, is to move the point bar 23 inwardly and outwardly with relation to the lace forming threads.

As indicated in Fig. 3 the point bars 23, 23^a operate successively upon the lace threads. As there shown, the point bar 23 has completed its upward movement, to move the locking threads engaged by it upwardly to proper position, while the point bar 23^a is just about entering between the threads. In this position of the bars, 23, 23^a, the cams 70, 80, and 70^a, 80^a, occupy the positions in which they are indicated by dotted lines in Fig. 1, with the bowls 69, 69^a, in engagement with the high and low parts of cams 70, 70^a, respectively, and the bowls 79, 79^a, in engagement with the low and high parts of cams 80, 80^a, respectively. As the shaft 49 continues to rotate in the direction indicated by the arrow (Fig. 1) the high part of cam 80 will engage the bowl 79 of lever 78 and, moving the free end of said lever upwardly, will, through the rock shaft 77, arm 76 and link 75, move the point bar 23 outwardly from engagement with the lace threads or toward the front of the machine. At the same time the arm 67, by reason of its connection with the stud 66, will be swung outwardly on its pivotal connection with the arm 68. The bowl 69 of arm 68 then rides down from the high part to the low part of cam 70, and the arm 68 and guide 71 move downwardly and, in doing so, through the arm 67, move the point bar 23 downwardly from the position shown in Fig. 1 to the position shown in Fig. 4. The rotation of shaft 49 being further continued the bowl 79 will move downwardly from the high part to the low part of cam 80 and thereby, through lever 79, rock shaft 77 and the other connections just referred to, move the point

bar 23 inwardly into engagement with the lace threads. Thereupon the bowl 69 will be engaged by the high part of cam 70 and the arm 68 and parts connected therewith will be moved upwardly so as to move the point bar 23 upwardly through the lace threads to the position in which it is shown in Fig. 3. The arrangement, on the cam shaft 49, of the cams 70^a, 80^a, for the rear point bar 23^a is the reverse of that of the cam 70, 80, for point bar 23, so that the point bars 23, 23^a, will operate successively, that is to say, as the point bar 23^a is moved inwardly between the lace threads the point bar 23 will be at its uppermost position between the threads (Fig. 3) and will remain in position between the threads until the point bar 23^a, having completed its inward movement between the threads, is moved upwardly therethrough below the point bar 23 whereupon the latter is fully withdrawn from between the threads and then moved downwardly and then inwardly between the threads as already described, and so on.

Heretofore, in lace making machines of the type herein illustrated, it has been the practice to support the main operating mechanism for the point bars and catch bars, in other words, the cam mechanism for the point bars and the crank mechanism for the catch bars, at points above the point bars and catch bars, and to also support some of the driving connections in front of the machine frame. Because of this, such machines have been of unnecessarily large size, over all, in height and depth, and inconvenient (and also unsafe while running) for the purposes of inspection, repair and adjustment of the machine parts or the materials operated upon. All of these inconveniences and objections are avoided in the machine provided by the present invention in which the cam mechanisms and crank mechanisms, together with the driving shaft therefor are arranged in a lower plane than the point bars and catch bars. These mechanisms are, as shown, also arranged outside and at the sides of the lace-making space of the machine, which is thus left free and unobstructed. This arrangement enables me to also locate the driving connections between the driving shaft and these cam and crank mechanisms, and the connections between the latter and the point and catch bars, below the point and catch bars, and to inclose all of these mechanisms and connections within the machine frame, in a space therein that has heretofore been wasted. Furthermore, the cam mechanisms and crank mechanisms being located within the machine frame and arranged outside and alongside the lace-making space they leave the front of the machine unobstructed so that the operator may, conveniently and with safety, closely approach the oper-

ating parts of the machine and inspect, repair and adjust the same, or the materials operated upon, whether the machine be operating or standing still. The arrangement of the mechanisms referred to beneath the point bars and catch bars brings them within convenient reach for such purposes.

The machine is equipped with a device for stopping the operation of the machine whenever from any cause one of the warp threads 14 breaks. The means provided for this purpose consists of a thin metal plate 85 for each of the threads 14, which, should its thread break, will drop down between a pair of rolls 86, 87, the former being movable relatively to the latter, which is driven, in any suitable way, from the driving mechanism of the machine or otherwise so as to feed the fallen plate downwardly. The movable roll 86 is pivotally mounted in a lever 88 fulcrumed at 89 in the machine frame, the opposite end of said lever being connected by a rod 90 connected with the switch 6 which controls the circuit between a source of electric supply and the electric motor (not shown) which drives the main shaft 5. Should one of the plates 85 fall between the rolls 86, 87, it will be fed down from the roll 87 and, in doing so, rock the arm 88 and thereby move rod 90 so as to open switch 6 and thus arrest the operation of the machine. In order to insure the delivery of a falling plate 85 between the rolls 86, 87, guides 91, 92 are provided which converge at their lower ends above the rolls 86, 87. This stopping mechanism, operated automatically on the breaking of a thread, is a very important feature of my invention. In all lace-making machines threads are liable to break and when this occurs the machine must be stopped so that the break may be repaired. Because of this it has always been necessary to have for each machine a skilled operator, one of whose most important duties was to constantly watch the multitude of moving threads so as to discover breaks as soon as they occur. Notwithstanding the watchfulness of such operator, however, it frequently happens that a break will occur without his immediately observing it, with the result that the lace made will be imperfect in spots, which must be mended or repaired, and the further result that the machine will have to be stopped for a very substantial length of time, while he laboriously re-threads the machine with and then ties together the ends of the broken thread. The loss of material or time, in such cases, through imperfections

thus occurring in the lace, and through stoppage of the machine, present serious difficulties for which no remedy had ever been suggested prior to my invention from the advent of lace-making machines down to the present time, beyond the employment of a highly-skilled, watchful operator for each machine. With my automatically-operated stopping mechanism the breaking of a thread is instantly made known to the attendant by the stopping of the machine, so that watching of the threads by him is no longer necessary and the break may be repaired by him with very little laborious re-threading of the thread through the machine, with the production of a minimum of imperfect lace to be subsequently mended, and without any substantial loss of time due to stoppage of the machine. Furthermore, while prior to my invention it was always found necessary to employ a highly-skilled, watchful attendant for each machine, an entirely unskilled attendant may be employed with my machine with equally good results, and his or her duties are so reduced by the provisions of my automatically-operated stopping mechanism that one such attendant can take care of several machines simultaneously, the expense of running these machines and therefore of making lace being very materially reduced.

The term "lace-making machine" as used herein and in the following claims is meant to refer to machines which make not only the net but also the ornamental part of the lace.

What I claim is:—

1. In a lace making machine the combination of point bars and catch bars and main operating mechanism therefor located in a lower plane than said bars, with a lace making space between it and said bars, and operating connections, at opposite ends of the machine and beyond the lace making space, extending upwardly from said operating mechanism to said bars.

2. In a lace making machine the combination of point bars and catch bars and main operating mechanism therefor located in rear of the front frame of the machine and in a lower plane than said bars, with a lace making space between said mechanism and said bars, and operating connections, at opposite ends of the machine and beyond the lace making space, extending upwardly from said operating mechanism to said bars.

In testimony whereof I have hereunto set my hand.

PERCY GREENWOOD.