

June 18, 1929.

J. ALMOND

1,718,198

HARNES MOTION FOR LOOMS

Filed May 9, 1928

2 Sheets-Sheet 1

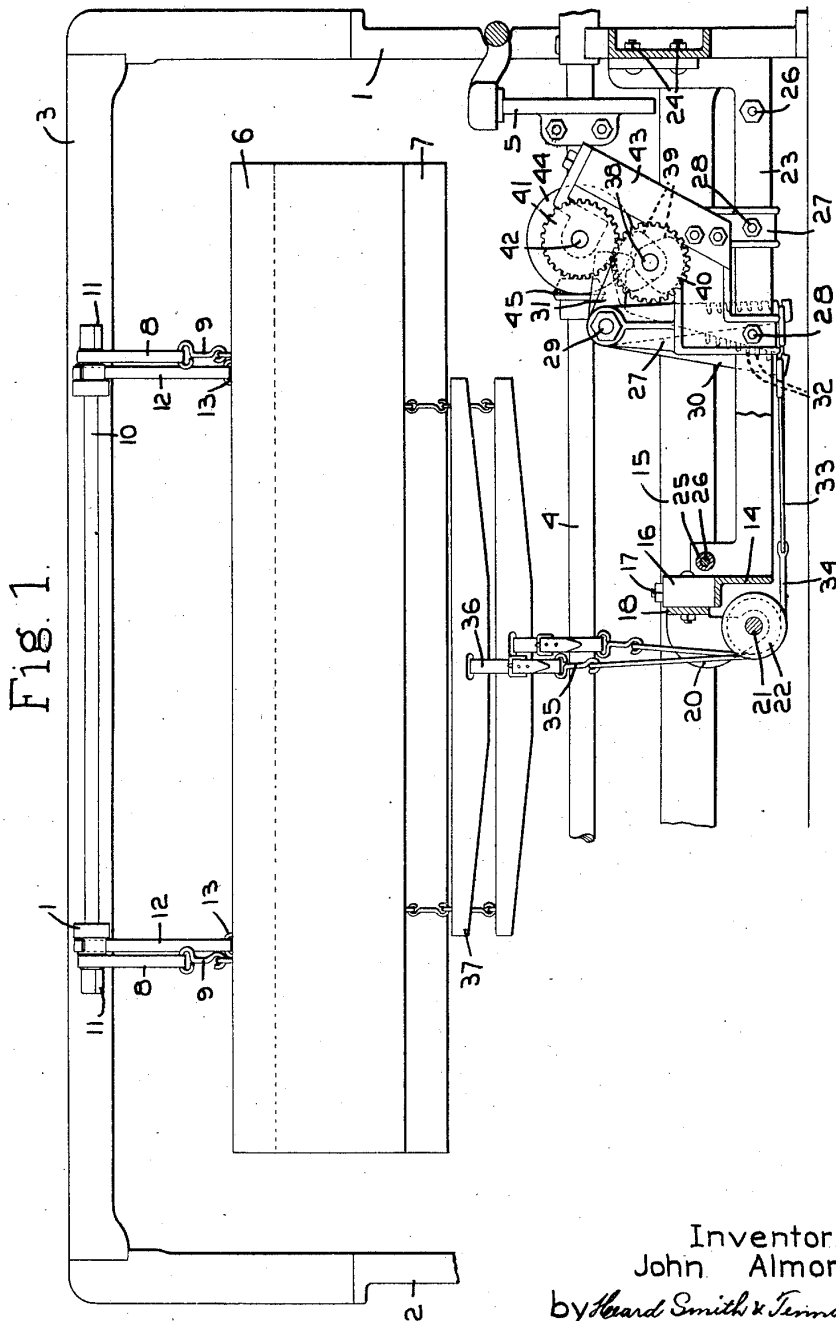

Fig. 1.

Inventor.
John Almond
by *Harold Smith & Tennant.*
Attys.

June 18, 1929.

J. ALMOND

1,718,198

HARNESS MOTION FOR LOOMS

Filed May 9, 1928

2 Sheets-Sheet 2

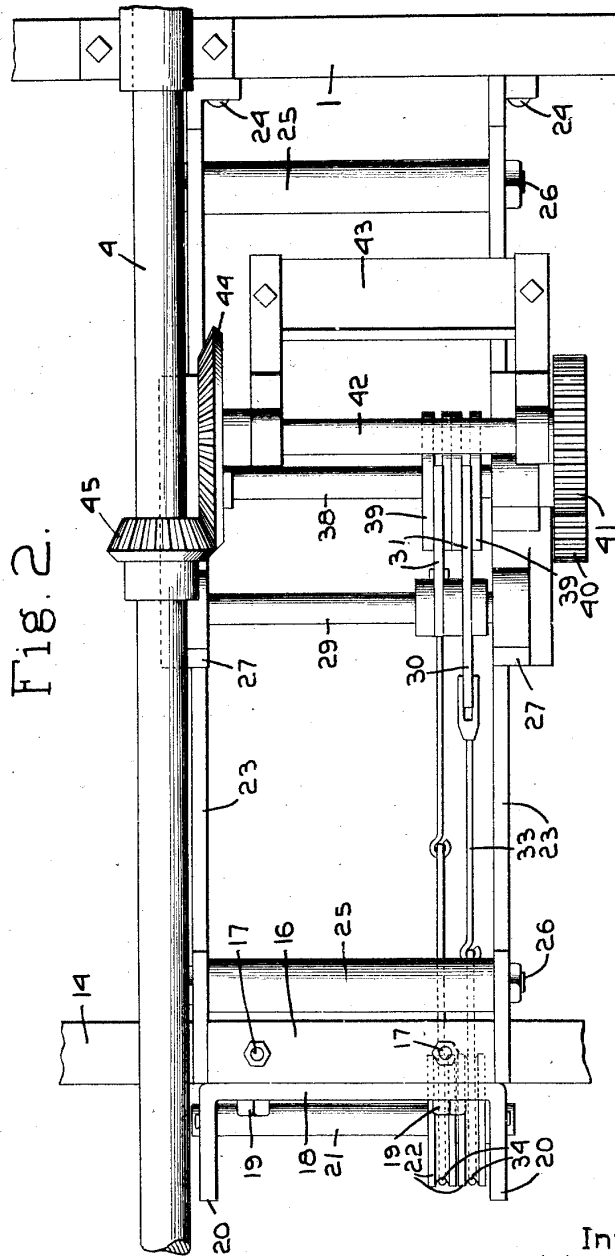

Fig. 2.

Inventor.
John Almond
by *Beard Smith & Tennant.*
Attys.

UNITED STATES PATENT OFFICE.

JOHN ALMOND, OF METHUEN, MASSACHUSETTS, ASSIGNOR TO DRAPER CORPORATION,
OF HOPEDALE, MASSACHUSETTS, A CORPORATION OF MAINE.

HARNESSES MOTION FOR LOOMS.

Application filed May 9, 1928. Serial No. 276,471.

This invention relates to a harness motion or shed forming mechanism for looms.

The object of the invention is to provide a simple and compact form of mechanism for operating two or more harness frames entirely located inside the loom frame between one of the side frame members and the center of the loom and beneath the harness frames.

The object of the invention is further to provide such a shed forming mechanism in which the levers for operating the harness frames have their arms connected to the frames by flexible connectors and extending vertically so that the swinging motion of the levers and any adjustment of the connectors to the levers take place without interfering with the vertical rectilinear movement of the harness frames.

These and other objects and features of the invention will appear more fully from the accompanying description and drawings and will be particularly pointed out in the claims.

The drawings illustrate only so much of an ordinary type of loom as is necessary to disclose a preferred embodiment of the invention and the essential location of such an embodiment in the loom.

In the drawings:

Fig. 1 is a front elevation of a portion of the loom frame and arch showing a pair of harness frames and a mechanism embodying the invention.

Fig. 2 is a top plan view on a larger scale of the mechanism for operating the harness frames and the adjacent portion of the loom frame.

The invention is applicable to any type of loom wherein two or more harness frames are employed and where the weave to be made is such that the harness frames may be operated after the manner of the ordinary cam type of shed forming mechanism.

A portion of a loom frame is shown comprising the side frame members 1 and 2 and the arch 3. The usual cam shaft 4 is shown extending between the side frame members and carrying, in Fig. 1, the pick cam 5.

Any required number of harness frames may be employed that can be operated with this type of mechanism. It is sufficient to illustrate two such frames because the addi-

tion of further frames simply requires the addition of corresponding connections, levers and cams. Preferably, the harness frames are arranged in pairs, one such pair being shown. Suitable suspending connections from the arch of the loom frame to the harness frames are provided, but preferably these suspending connections are also arranged in pairs with one member extending from one harness frame to the loom frame and the other member back from the loom frame to the other harness frame to permit the vertical movement of the harness frames in reverse phase. Thus the harness frames 6 and 7 near each end have suspending connections comprising a flexible member 8 attached at its lower end by a hook 9 to the frame 6 and at its upper end connected to a drum on the shaft 10 journaled at 11 on the arch 3 and comprising a flexible member 12 attached at its lower end by a hook 13 to the frame 7 and at its upper end connected to another drum on the shaft 10. The connections 8 and 12 extend in opposite directions around the respective drums. Consequently as one harness frame rises or falls, the other harness frame falls or rises in alternation therewith.

The harness frames are arranged in vertical parallelism, preferably in pairs, and any number as required by the weave.

The harness frames are operated from beneath in this invention and the mechanism for thus operating the harness frames is located entirely inside of the loom frame between one side frame member, such as 1, and the center of the loom. Thus the operating mechanism for effecting the shedding motion is arranged very compactly and entirely within the confines of the loom frame.

In the preferred construction illustrated, an auxiliary framework for supporting the operating mechanism is secured to or built into the loom frame. For this purpose an angle iron 14 is secured to the loom frame and extends fore and aft between the lower girders, one of which is shown at 15. A wooden block 16 is bolted at 17 to the top of this angle iron. A bracket 18 is bolted at 19 to the left-hand side of the block 16 and presents at each end depending arms 20 supporting a shaft 21 on which is journaled be-

neath the center of the harness frames a plurality of idler pulleys 22. These pulleys constitute deflecting means for the flexible connections extending to the bottom of the harness frames.

Frame bars 23 rest at one end upon the angle iron 14 and extend therefrom in parallelism to the side frame 1 of the loom and are secured thereto by bolts 24. These frame bars are braced longitudinally of the loom by sleeves 25 clamped up by bolts 26 extending therethrough. Upstanding brackets 27 are secured by the bolts 28 to the frame bars 23 near the center thereof and carry at their upper ends a shaft 29 extending beneath and at right angles to the harness frames. Upon this shaft is fulcrumed the required plurality of operating levers, one for each harness frame. In the preferred form of the invention, each lever is of the bell crank type having one arm 30 extending vertically downward from the fulcrum and the other arm 31 extending laterally from the fulcrum. But the essential feature is that the arm of the lever which is connected to the corresponding harness frame shall extend substantially vertically from its fulcrum and shall swing in a plane parallel with and beneath the harness frames. This operating arm 30 is provided along its edge with notches 32 by means of which the connection to the harness frame may be adjusted to vary the throw of the harness frame. Each connection from the lever to the corresponding harness frame is shown as a flexible connector including a link 33 engaging one of the notches 32 at one end, a belt or strap 34 extending from the other end of the link 33 around the corresponding idler pulley 22 to a hook 35 and strap 36 connected to a bar 37 in turn connected to the bottom of the corresponding harness frame.

It will thus be seen that no matter what notch 32 may be engaged by the flexible connector, and no matter what may be the swing of the lever 30, the movement of the harness frame will always be vertical and rectilinear.

Suitable means are provided for operating the levers, but these means are located between the side frame member, such as 1, of the loom and the center of the loom and beneath the harness frames. In the preferred form of the invention, a cam mechanism such as illustrated is employed. For this purpose a shaft 38 is journalled in bearings in the brackets 27 extending parallel with the fulcrum shaft 29. Upon this shaft are secured a plurality of cams 39, one for each lever 30. In the preferred construction the cam shaft 38 is beneath the lateral arms 31 of the levers and the cams are of substantially the shape shown, with the members of each pair of cams alternating diametrically so as to give the required alternation of the movement of the harness frames. The cam shaft

38 is shown as carrying at one end a gear 40 intermeshing with a gear 41 on a parallel shaft 42 journalled in a bracket 43 upstanding from and supported by the bracket 27. This shaft 42 carries at its opposite end a bevelled gear 44 meshing with and driven by a bevelled pinion 45 secured to the cam shaft 4.

The operation of the mechanism will be apparent. The rotation of the main cam shaft 4 is imparted to the cam shaft 38, thus rotating the cams 39 which in turn operate the levers 30 to effect the required shedding motion. Preferably, as shown, the levers and harness frames are arranged in pairs, but any desired grouping of the harness frames and levers and of the cams and any desired configuration of the cams may be employed.

It will be seen that the entire mechanism is located and operates between one side frame member of the loom and the center of the loom and beneath the harness frames, and that the levers are arranged parallel with the respective harness frames and are fulcrumed on an axis extending beneath and at right angles to the harness frames, and that one arm of each lever extends vertically, and preferably downward, from its fulcrum. There is thus produced a very simple, compact and efficient mechanism for operating the harness frames.

Having thus described the invention, what is claimed as new, and desired to be secured by Letters Patent, is:

1. In a loom having a frame with side members, shed forming mechanism comprising a pair of parallel vertically movable harness frames, suspending connections from the harness frames to the loom frame, a pair of levers located and operating between one side frame member and the center of the loom beneath and parallel with the respective harness frames and fulcrumed on an axis extending beneath and at right angles to the harness frames with one arm of each lever extending vertically from the fulcrum, deflecting means beneath the harness frames, a flexible connector extending from each harness frame down around the deflecting means to the vertical arm of the corresponding lever, a cam shaft parallel with the fulcrum axis, a pair of cams on said shaft co-acting respectively with the levers, and means for rotating the cam shaft thereby to effect the required shedding motion.

2. In a loom having a frame with side members, shed forming mechanism comprising a pair of parallel vertically movable harness frames, suspending connections from the harness frames to the loom frame, a pair of levers located and operating between one side frame member and the center of the loom beneath and parallel with the respective harness frames and fulcrumed on an axis extending beneath and at right angles to the harness

frames with one arm of each lever extending vertically from the fulcrum, deflecting means beneath the harness frames, a flexible connector extending from each harness frame
 5 down around the deflecting means to the vertical arm of the corresponding lever, and means located between said side frame member and the center of the loom beneath the harness frames for operating the levers in
 10 alternation to effect the shedding motion.

3. In a loom having a frame with side members, shed forming mechanism comprising a pair of parallel vertically movable harness frames, suspending connections from the harness frames to the loom frame, a pair of bell
 15 crank levers located and operating between one side frame member and the center of the loom beneath and parallel with the respective harness frames and fulcrumed on an axis extending beneath and at right angles to the
 20 harness frames with one arm of each lever extending vertically downward and the other arm extending laterally from the fulcrum, deflecting means beneath the harness frames, a flexible connector extending from each harness
 25 frame down around the deflecting means to the vertical arm of the corresponding lever, a cam shaft parallel with the fulcrum axis, a pair of cams on said shaft co-acting respectively with the lateral arms of the levers, and
 30 means for rotating the cam shaft thereby to effect the required shedding motion.

4. In a loom having a frame with side members, shed forming mechanism comprising
 35 a pair of parallel vertically movable harness frames, suspending connections from the harness frames to the loom frame, a pair of bell crank levers located and operating between one side frame member and the center
 40 of the loom beneath and parallel with the respective harness frames and fulcrumed on an axis extending beneath and at right angles to the harness frames with one arm of each lever extending vertically downward and the other
 45 arm extending laterally from the fulcrum, deflecting means beneath the harness frames, a flexible connector extending from each harness frame down around the deflecting means to the vertical arm of the corresponding lever,
 50 and means located between said side frame member and the center of the loom beneath the harness frames engaging the lateral arms of the levers and operating the levers in alternation to effect the shedding motion.

5. In a loom having a frame with side members, shed forming mechanism comprising
 55 a plurality of parallel vertically movable harness frames, suspending connections from the harness frames to the loom, a plurality of levers located and operating between one side frame member and the center of the loom beneath
 60 and parallel with the respective harness frames and fulcrumed on an axis extending beneath and at right angles to the harness frames with one arm of each lever extending
 65 frames with one arm of each lever extending

vertically from the fulcrum, deflecting means beneath the harness frames, a flexible connector extending from each harness frame down
 70 around the deflecting means to the vertical arm of the corresponding lever, a cam shaft parallel with the fulcrum axis, a plurality of cams on said shaft co-acting respectively with the levers, and means for rotating the cam shaft thereby to effect the required shedding
 75 motion.

6. In a loom having a frame with side members, shed forming mechanism comprising
 80 a plurality of parallel vertically movable harness frames, suspending connections from the harness frames to the loom, a plurality of levers located and operating between one side frame member and the center of the loom beneath and parallel with the respective harness
 85 frames and fulcrumed on an axis extending beneath and at right angles to the harness frames with one arm of each lever extending vertically from the fulcrum, deflecting means beneath the harness frames, a flexible connector extending from each harness frame down
 90 around the deflecting means to the vertical arm of the corresponding lever, and means located between said side frame member and the center of the loom beneath the harness frames for operating the levers to effect the
 95 required shedding motion.

7. In a loom having a frame with side members, shed forming mechanism comprising
 100 a plurality of parallel vertically movable harness frames, suspending connections from the harness frames to the loom, a plurality of bell crank levers located and operating between one side frame member and the center of the loom beneath and parallel with the
 105 respective harness frames and fulcrumed on an axis extending beneath and at right angles to the harness frames with one arm of each lever extending vertically downward and the other arm extending laterally from the fulcrum, deflecting means beneath the harness frames,
 110 a flexible connector extending from each harness frame down around the deflecting means to the vertical arm of the corresponding lever, a cam shaft parallel with the fulcrum axis, a plurality of cams on said shaft co-acting respectively with the lateral arms of the levers,
 115 and means for rotating the cam shaft thereby to effect the required shedding motion.

8. In a loom having a frame with side members, shed forming mechanism comprising
 120 a plurality of parallel vertically movable harness frames, suspending connections from the harness frames to the loom, a plurality of bell crank levers located and operating between one side frame member and the center of the loom beneath and parallel with the
 125 respective harness frames and fulcrumed on an axis extending beneath and at right angles to the harness frames with one arm of each lever extending vertically downward and the other arm extending laterally from the ful-
 130

crum, deflecting means beneath the harness frames, a flexible connector extending from each harness frame down around the deflecting means to the vertical arm of the corresponding lever, and means located between said side frame member and the center of the loom beneath the harness frames engag-

ing the lateral arms of the levers and operating the levers in alternation to effect the shedding motion.

In testimony whereof, I have signed my name to this specification.

JOHN ALMOND.