

The
H
A
N
D
I
C
R
A
F
T
E
R

November-December
1931



Price
Forty
Cents

"HANDCRAFT" is certainly a book which no craft class should be without

It offers to handicrafters a hundred-and-one projects, simply planned and complete with full sized patterns and instructions easy to follow and requiring the minimum of inexpensive tools.

"HANDCRAFT" takes the child step by step along the road of adventure in this creative art; and mastery of the book only increases the student's enthusiasm to create designs and ideas of his own.

From the full sized diagrams contained in the book, stencils can be cut for the use of parent, school or church teacher, summer camp or playground director.

Again, the simplicity and low cost of making these articles makes the "HANDCRAFT" book doubly attractive. And at a price to suit the most slender purse.

\$1.50 per Copy

Write for your copy of "HANDCRAFT" today. Send money order, stamps or check to

NATIONAL RECREATION ASSOCIATION

315 Fourth Avenue, New York City



3222 Lake Shore Avenue
OAKLAND + CALIFORNIA

◆◆◆ LOOM BUILDERS ◆◆◆

Hand Looms + Foot-Power Looms + Gobelin and Tapestry Looms
Two-Harness and Up—to Your Specifications + Any Size and Material

LET US QUOTE YOU

PACIFIC COAST DEPOT FOR

BERNAT "WEAVERITE" YARNS

FOR YOUR CONVENIENCE AT FACTORY PRICES + SERVICE DE LUXE

November
December
1931
Vol. III No. 7

THE HANDICRAFTER

\$2.00 per year
40 cents per copy
Canada and Foreign
\$3.00 per year

Published six times a year in August, October, December, February, April and June by Emile Bernat & Sons Co., Publication Office, 10 Ferry St., Concord, N. H., Editorial Office, 89 Bickford St., Jamaica Plain, Massachusetts. Printed in U. S. A. Material in this magazine is available for reprinting only on expressed permission of the publishers. Entered as second-class matter, August 1, 1931 at the Post Office at Concord, N. H., under the Act of March 3, 1879.

PAUL BERNAT, *Editor*

Associate Editors

MARJORIE AMES
New York City

ELLA S. BOWLES
Franconia, N. H.

PAULINE SCHINDLER
California

CONTENTS

☞ THE HANDICRAFTER welcomes contributions of articles with or without photographs or illustrations. To get the best results for reproduction, photographs should be on glossy paper and drawings must be in India ink.

☞ The publishers can assume no responsibility however, for the safety of either manuscripts or photographs, though due care will be exercised in their return if considered unavailable.

Editorial	2
Handwoven Curtains <i>Virginia S. Doan</i>	3
Further Notes on Speck Drafts. <i>R. F. Heartz</i>	7
The Shuttle-Craft Guild of Hand-Weavers	12
Handweaving on Loom Frames — Part II The Kircher Loom <i>Cecelia Cleveland Willard</i>	16
A Traveling Exhibit of Hand Weaving.	21
Attention! Boys and Girls — Make Your Own Christmas Gifts <i>Helen Perry Curtis</i>	22
The Pros and Cons of Fly-Shuttle Weaving <i>Florence B. Cathcart</i>	26
Block printing your own Christmas Cards <i>M. Louis Arnold</i>	27
Silver Bookends and a Bracelet <i>Mary Angood</i>	31
A Utility Bag <i>Hermine Roberts</i>	34
The 1931 Weaving Institute at Penland	36

Willa-Craft Studios

Correspondence Course "Adaptations of Tapestry Weaves"

(Just published, copyright 1930)

Consists of 10 lessons and includes Embroidery Weaves, and also Spanish, Coptic, Tapestry and Laid-in methods.

The course is illustrated with blueprints and each lesson is demonstrated with woven sample.

Full course, with reply to questions and criticism \$30.00

Full course, without supplementary correspondence 20.00

Single lessons with reply to questions and criticism 4.00

Single lesson, without supplementary correspondence 3.00

CECELIA CLEVELAND WILLARD
82 East End Avenue New York, N. Y.

HAMMETT'S



The "Tawido" Belt Loom is one of the many types offered in our weaving catalog.

Send for free weaving and art material catalog; also free Basketry catalog

J. L. HAMMETT & CO.
Established 1863 CAMBRIDGE, MASS.

Editorial

THE more lenient and laudatory attitude displayed by art critics towards the minor arts of the past opens up an interesting vista on the relative positions of artists and craftsmen. In a previous editorial we discussed the rôles of craftsmen and artists in society, granting that the artist possesses a greater modicum of genius and is motivated by higher aspirations. The height an artist must attain to be worthy of his rôle, however, requires a plethora of imagination and a knowledge of sentience that is rare in most humans.

In perusing the critical works of our best authorities, we find that very little is accepted wholeheartedly. In the last month the writer read two books of this sort — one on art, the other on literature. Sitwell, in his book, "The Gothick North," brands cathedrals like Rheims cumbersome piles of masonry; Zweig, in his book, "Three Masters," refers to an author like Zola as a portrayer of wooden characters, meticulously wrought but devoid of reality. When one considers the years of labor merged in the erecting of the Gothic cathedral, then to be told a little chapel in Portugal is far finer as a work of art, we can wonder if the rôle of "artist" should be lightly taken and whether the craftsman though attempting less is not in a preferable position.

Further perusal of Sitwell's delightful book brings us to his chapter on Gothic tapestry for which he has unstinted praise while dilating on the extraordinary power of depiction, gorgeous coloring, and overwhelming grandeur of design revealed in these masterpieces of weaving. Yet tapestries are the creations of artist craftsmen and picayune in conception alongside the vastness of the city cathedrals. The limited conception in a tapestry provides for greater surety of success. Gothic tapestry narrated in stilled action, charming color, and entrancing composition; it captivates the aesthetic mind, but does not sway with clash of grandiose theory, new concepts, or positive portrayal.

The tapestry weaver did not lay over-much stress on the dramatic, nor was he the prophet; his power lay in his understanding of the materials with which he worked and his ability to achieve a decorative effect. It is a much simpler task for a craftsman to build a chair that is harmonious in proportion and comfortable than for a sculptor to breathe sentience into an equestrienne statue. In a flourishing craft age like the Kang Hsi in porcelain, the great bulk of the productions were fine; in a statue-producing age like the past fifty years, there have been thousands of productions, yet many

critics brand virtually all of them as devoid of real artistic value.

The crafts have had their ups and downs; yet excepting a few periods in which they were travesties on the artistic impulse, their outpourings are accepted as faithful renderings of an artistic spirit and worthy of retention. In examining or criticizing a craftsman's work, our approach is different than that to a painting or sculpture. In a chair we expect harmony of line, comfort, good cabinet-making, well grained and colored wood; in a jewelled reliquary we look for exquisite workmanship, delicate lines, charming conception; should there be human, animal, or plant forms, we do not expect the figuration to be so real that the human could step off the reliquary, or the leaf flutter with a sigh of wind. From the portraitist, though, we demand original composition, spiritual reality, delving into the human character. Simpler is the task of the craftsman, much less is expected, far more amplified is the background with which he works. The cabinetmaker has dozens of models in the current style, and need only modify to be creative; with the portraitist each commission is a new task, and a museum of masterpieces will not make an artist of him or a work of art of his portrait if he lacks the requisite genius and imagination.

That the craftsman can use a host of models for his own productions is not a reflection on himself; it is the chance boon that emanates from the limitations of his craft. The minor arts are too restricted in scope to allow for free play of imagination. A table must conform to set restrictions in its utility and the style mode; but in a sculpture there is no limit, and if it is portrayal there must be the ability to catch the inner spiritual content as well as the reality. The greater the amount of variation, the more imagination required; the more dependent is success on the ability of the artist.

The very fact that in the crafts we talk in terms of periods and in the higher arts of artists is evidence of the difference. Most craftsmen have not been individual enough to clear new paths — there have been few Chippendales; but hundreds of artists have lived and are remembered. The craftsmen have lost and gained through this anomaly; but success within their limitations has not been over-difficult to attain. Today the craftsman can also profit from his position. The fame and achievement of a Masacio is worth all the struggles that are thrust in oblivion; but also the proud record of the Gothic tapestry weavers is valuable, and therein is a host, while the other is remembered in a solitary individual.

Editor's Note. — The illustration on the cover page is that of an Egypto-Roman tapestry woven in the sixth century A.D. This tapestry is but four inches by four wide, and has silk warp, sixty threads to the inch. The tapestry is in the Victoria and Albert Museum of London, and this illustration is used through the courtesy of Luther Hooker, Esq., who made the water color sketch of which the photograph was taken. Mr. Hooker is now preparing a series of articles on tapestry weaving that will appear in coming numbers of the HANDICRAFTER. The first article will appear in the February number.

Handwoven Curtains

BY VIRGINIA S. DOAN

HOUSEKEEPING a year, and no curtains in the dining room. It really was a family disgrace, and yet I had the idea (peculiar, to say the least, but not unusual among craftsmen) that they must be handwoven; but how one person could warp a 44-inch loom was a mystery to me. Finally, with the help of three friends who had never even seen a loom before, we warped it, using 20/3 Egyptian cotton and threading it in one of Mary M. Atwater's adaptations of one of John Landes patterns taken from an old coverlet in the Philadelphia Museum. This pattern is a combination of the whig rose and chariot wheel. Any other pattern might be used; for instance, the rose path or honeysuckle patterns. The warp was 20 yards long, enough to weave the curtains and a coverlet which I wanted to make, using this same pattern. I repeated the unit of the pattern five times, and tied a piece of string to the first heddle of the last group, so that by simply unthreading the last group and threading in the

border, my loom was ready to weave the coverlet without unthreading the entire loom. The threads were threaded two in each reed of a beater with reeds, fifteen to an inch, making thirty threads to the inch. The extra warp threads turned out to be a great blessing in figuring the amount of warp left on the loom, and I do not think I shall ever set up a loom without leaving an extra thread at one side to help measure the remaining yardage. When making the coverlet I tied extra pieces of thread

to the last unit of the design, re-threaded these through the heddles and the beater, and wrapped these ends around common pins, which had been pinned through the material just woven, pulling the ends tight enough to make the tension the same

as in the other part of the loom. The extra threads I threaded in place and tied them to the beam with a piece of ribbon. Next I shot a few inches of cloth through the shed to separate the threads evenly, and I was ready to proceed.

To return to the story of my curtains: in order to speed up the work of making them, I chose the heaviest material I could find, a mercerized thread, No. 3 perle cotton, in sand shade. It turned out to be a happy accident, as the sand when woven through the white warp gave a very pretty texture and, when hanging at the windows, have a transparent, almost gold effect with the light shining through them.

Weave 8 inches of plain weave, then the following narrow border: two rows plain weave (blue), one row plain weave (sand), and the following, called the key, which gives every possible combination of the pedals of the loom and is a great help in weaving, especially in designing borders. A Danish teacher taught me to always weave the key in every piece of weaving, as it may be a great help to refer to it later, and it can be worked into most any design.

Then:

Pedals 1 and 2, orange, 1 row
 " 2 " 3, " 1 "



Handwoven Curtain

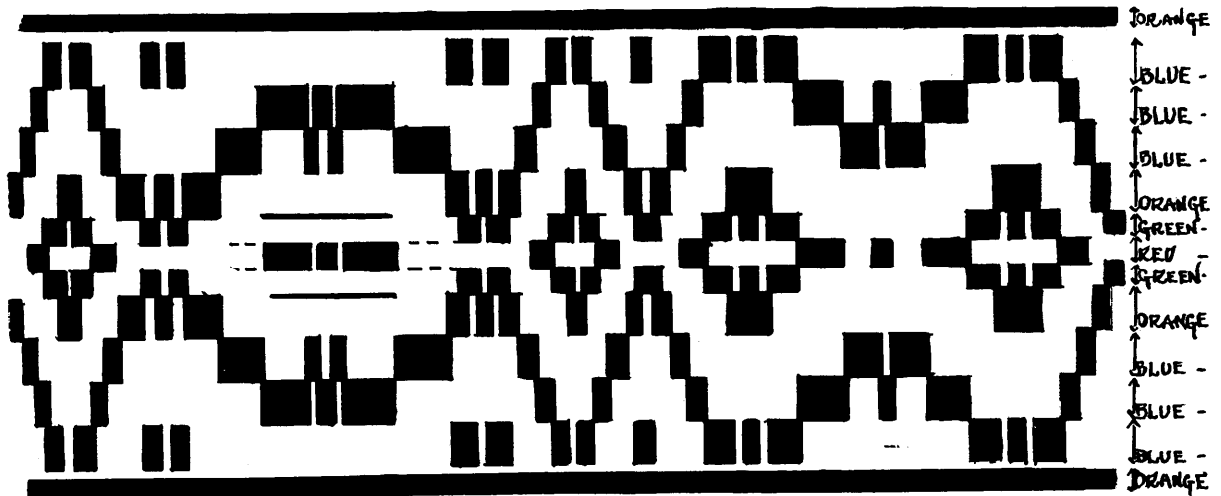
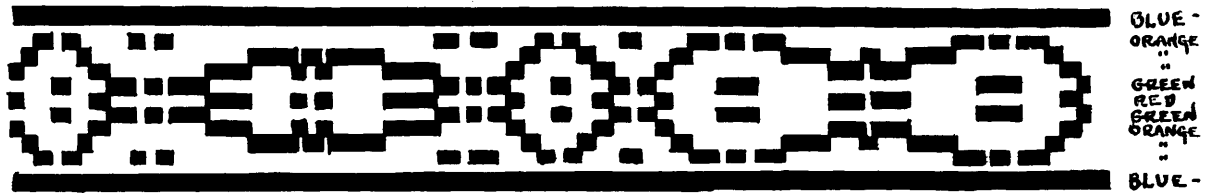

DESIGN FOR CURTAIN BORDER-

Pedals 3 and 4, orange, 1 row
 " 1 " 4, green, 1 "
 " 3 " 4, red, 1 "
 " 1 " 4, green, 1 "
 " 3 " 4, orange, 1 "
 " 2 " 3, " 1 "
 " 1 " 2, " 1 "
 1 row sand, plain weave
 2 rows blue, plain weave
 9 rows sand color
 2 rows orange, plain weave
 1 row sand, plain weave
 Pedals 1 and 2, blue, 4 times
 " 2 " 3, " 4 "
 " 3 " 4, " 4 "
 " 1 " 4, orange, 4 "
 " 1 " 2, green, 2 "
 " 2 " 3, red, 2 "
 " 1 " 2, green, 2 "
 " 1 " 4, orange, 4 "
 " 3 " 4, blue, 4 "
 " 2 " 3, " 4 "
 " 1 " 2, " 4 "
 1 row sand (plain).
 2 rows orange "
 9 " sand "
 Repeat key.

Now weave $7\frac{5}{8}$ inches sand, plain weave, which will shrink to 7 inches when the material is removed from the loom. Then with the shuttle thread on the left-hand side of the loom, weave the following stripe, using the sand-colored thread for both the pattern and the binder:

(1 and 2), 1 time	(1 and 2), 1 time
(2 " 4), 1 "	(2 " 4), 1 "
(2 " 3), 1 "	(2 " 3), 1 "
(1 " 3), 1 "	

This little stripe adds to the hand-woven effect and at the same time is a big help in measuring your material.

Repeat $7\frac{5}{8}$ inches of plain weaving as many times as desired for the length of your curtains. Then repeat the "key" and weave 10 inches plain weave in sand color for the heading at the top of the curtain.

I was quite pleased to discover while weaving these curtains that by weaving about 8 inches of my second curtain I could cut off my first one and pin the second one to the apron on my loom with common pins, placing them about every inch apart. This is sometimes a great saving in warp if a person desires to cut off one article on the loom without sacrificing valuable inches of warp, which may be just enough for certain planned work.

Of course, some people do not like fringe (I do not like the movie theatre kind, either) but, to take away the hand-tied fringe on handwoven articles, part of the handicraft look is lost, so I tied twelve threads together all the way across, allowing 6 inches for fringe. If you would add a certain Czechoslovakian look to them, tie a second row of knots in the following manner, numbering these groups, from left to right, one to nine, making the second row of knots about $\frac{7}{8}$ inch below the first row (measuring diagonally), or $\frac{5}{8}$ inch below (measuring in a straight line):

- 1 and 3 knotted sections together
- 2 " 5 " " "
- 3 " 7 " " "
- 6 " 9 " " "
- 8 " 11 " " " , etc.

The curtains may be simply hemmed at the top edge and gathered on the rod, but I think they are more attractive if they are hung on rings with folds, as "draw curtains" are made. A special ring with an upper and lower projection may be pur-

chased in the drapery section of a dry goods store for 50 cents a dozen. It requires about six for each yard. Made in this way these curtains answer for glass curtains and drapes as well, and may solve the problem of curtaining a difficult arrangement of windows. Mine were 42 inches wide and, with one-half pound, 34 inches could be woven so at \$2.00 a pound. It really makes very inexpensive curtains. You must be sure, however, to measure your windows carefully and to allow for the shrinkage when the material is removed from the loom. I found that out of every 8 inches woven and measured on the loom, I would have about a shrinkage of almost an inch.

For the border I used wool yarn in order to obtain the shades which I desired for my room, and I liked the effect. For a binder I used the same sand mercerized thread.

THREAD-UP FOR CURTAINS:

- (3 and 4), 1 time (3 and 4), 6 times
- (1 " 4), 1 " (1 " 4), 5 "

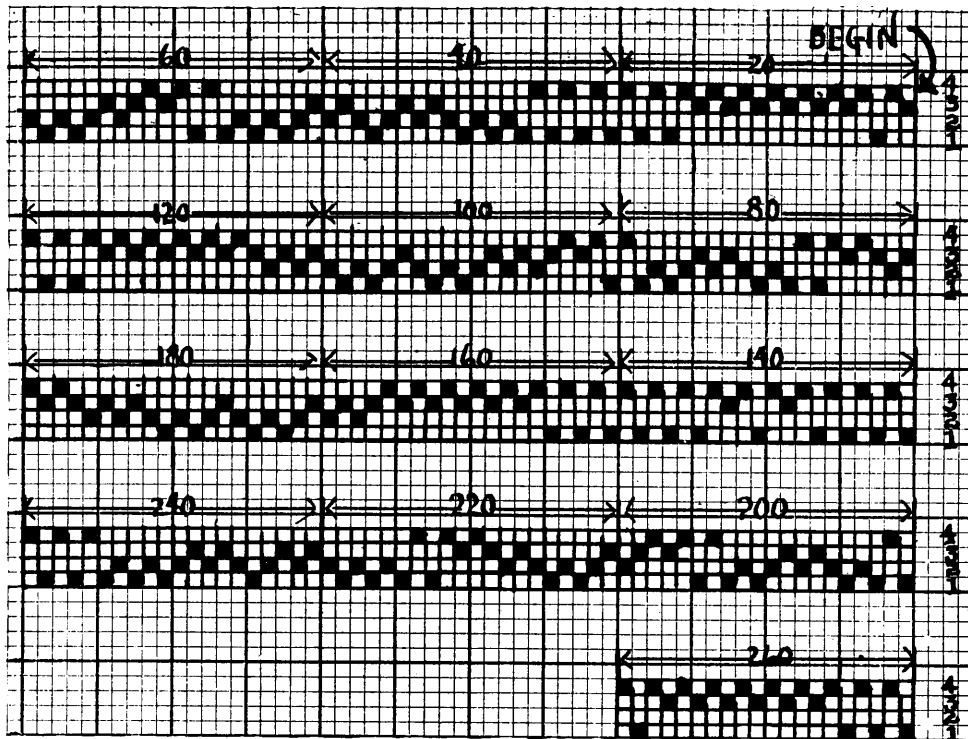

Repeat 5 times for curtains. Repeat 4 times END 78. 46 to 78—7 times to make border for coverlet
Combination Whig Rose and Chariot Wheel



Repeat as often as desired for curtains Rose Path Pattern

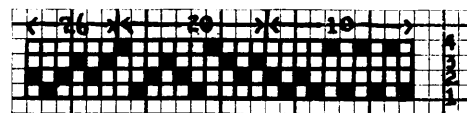

Repeat as often as desired for curtains Honeysuckle Pattern

(1 and 2), 3 times	(1 and 4), 2 times	(3 and 2), 1 times	(3 and 2), 1 times
(3 " 2), 2 "	(3 " 4), 1 "	(1 " 2), 2 "	(3 " 4), 2 "
(1 " 2), 1 "	(3 " 2), 3 "	(3 " 2), 3 "	(1 " 4), 1 "
(3 " 2), 2 "	(1 " 2), 2 "	(3 " 4), 2 "	(1 " 2), 3 "
(1 " 2), 2 "	(3 " 2), 1 "	(1 " 4), 1 "	(3 " 2), 2 "
<i>Thread No. 46</i>			
(1 and 4), 2 times	(1 " 2), 2 "	(1 " 2), 2 "	(1 " 2), 1 "
(3 " 4), 1 "	(3 " 2), 2 "	(3 " 2), 2 "	(3 " 2), 2 "
(3 " 2), 2 "	(3 " 4), 6 "	(1 " 2), 1 "	(1 " 2), 2 "
(1 " 2), 2 "	(1 " 4), 6 "	(1 " 4), 2 "	(1 " 4), 6 "
(3 " 2), 1 "	(3 " 4), 1 "	(3 " 4), 1 "	(3 " 4), 6 "
(3 " 4), 2 "	(1 " 4), 1 "	(3 " 2), 2 "	(1 " 4), 1 "
(1 " 4), 1 "	(middle)	(1 " 2), 2 "	
(1 " 2), 2 "	(3 and 4), 1 "		
(3 " 2), 2 "	(1 " 4), 6 "		
(1 " 2), 1 "	(3 " 4), 5 "		
	(3 " 2), 3 "		
	(1 " 2), 2 "		
Repeat five times for curtains.			
Repeat four times for coverlet and from beginning to star, and from thread No. 46 through thread No. 78 six or seven times for border.			

TREADINGLING FOR COVERLET

<i>First Section</i>	<i>Second Section</i>	<i>Third Section</i>
(3 and 4), 2 times	(2 and 3), 4 times	(3 and 4), 2 times
(1 " 4), 2 "	(1 " 2), 3 "	(1 " 4), 2 "
(3 " 4), 8 "	(2 " 3), 2 "	(1 " 2), 2 "
(1 " 4), 8 "	(1 " 2), 3 "	(2 " 3), 2 "
(1 " 2), 4 "	(2 " 3), 4 "	(1 " 2), 2 "
(2 " 3), 3 "	(3 " 4), 8 "	(1 " 4), 2 "
(1 " 2), 2 "	(1 " 4), 8 "	(3 " 4), 2 "
(2 " 3), 3 "	(3 " 4), 2 "	(2 " 3), 2 "
(1 " 2), 4 "	(1 " 4), 2 "	(1 " 2), 2 "
(1 " 4), 2 "	(3 " 4), 2 "	(2 " 3), 2 "
(3 " 4), 2 "	(1 " 4), 8 "	(3 " 4), 2 "
(2 " 3), 2 "	(3 " 4), 8 "	(1 " 4), 2 "
(1 " 2), 2 "	(2 " 3), 4 "	(1 " 2), 4 "
(2 " 3), 2 "	(1 " 2), 3 "	(2 " 3), 3 "
(3 " 4), 2 "	(2 " 3), 2 "	(1 " 2), 2 "
(1 " 4), 2 "	(1 " 2), 3 "	(2 " 3), 3 "
(2 " 3), 2 "	(2 " 3), 4 "	(1 " 2), 4 "
(1 " 2), 2 "		(1 " 4), 8 "
(1 " 4), 2 "		(3 " 4), 8 "
(3 " 4), 2 "		(1 " 4), 2 "

Repeat from beginning, First Section

You will note that "I" is exactly the opposite of "III" in pedals pushed down; "IV" exactly the opposite of "VI," "II" of "V," and the middle section of the pattern is the opposite of the beginning and end which comes together when the pattern is repeated.

Further Notes on the Speck Drafts

BY R. F. HEARTZ

THE notes as they appeared in the May-June issue of the *HANDICRAFTER* were not complete for weaving purposes, as they were originally intended for a collaboration of the notes of several weavers for a book review, so necessarily had to be brief. The Editor thought that they would be of interest, so he published them in their original form. It was planned that later they should be given in more detail with weaving directions, but because of the interest that they have aroused it

to try to tie them into the body of the cloth. This, of course, makes a distinct right and wrong side to the fabric because of the long overshots underneath, but the effect of the right side is most interesting and worth working for. The finished pieces are suitable for bags, pillows, upholstery, wall panels and any similar pieces that are backed or that can be lined.

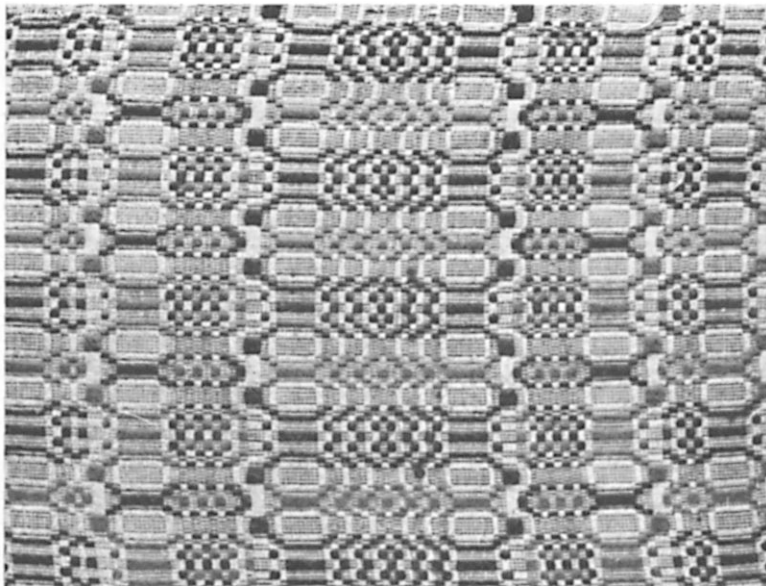

Fabric in Madder Red and Blue

Treadling draft for No. 5A Plain Overshot Draft:

1	8 times	3	4 times
2	4 "	4	4 "
3	4 "	1	8 "
4	20 "	2	4 "
3	4 "	3	4 "
2	4 "	4	20 "
4	2 "	3	4 "
2	4 "	2	4 "
3	4 "	4	4 "
4	4 "	3	4 "
1	8 "	2	4 "
2	4 "	4	4 "
3	4 "	3	4 "
4	20 "	2	4 "
3	4 "	4	4 "
2	4 "	3	4 "
4	2 "	2	4 "
2	2 "	4	4 "
4	2 "	3	4 "
2	2 "	2	4 "
4	2 "	4	4 "
2	4 "		

has been found expedient to prepare them for immediate publication.

Draft No. 5. The suggestions made for weaving this pattern in two colors were not found to be wholly satisfactory, though it can be accomplished. An easier way of doing it was worked out, and is given below. The drawing-in drafts were not changed, but in weaving with the tie-up and treadling drafts as given for two-color weaving on the overshoot principle, the filling up of the two strands of weft in one pick of the pattern and also the showing through of the two colors between the warp threads, so affected the design that it is not wholly practical.

The better arrangement is to allow the pattern yarns to float on the back of the fabric rather than

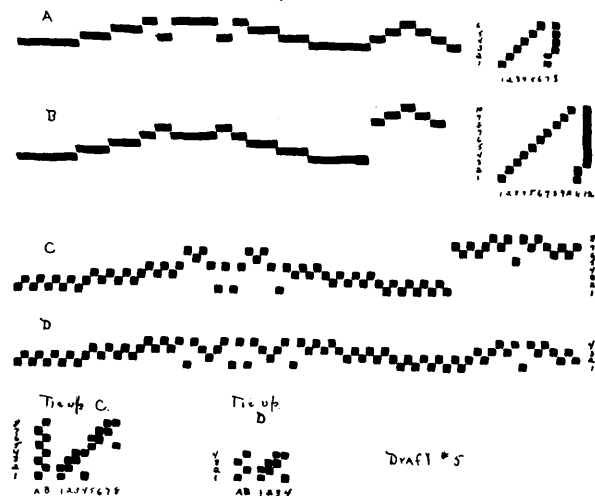

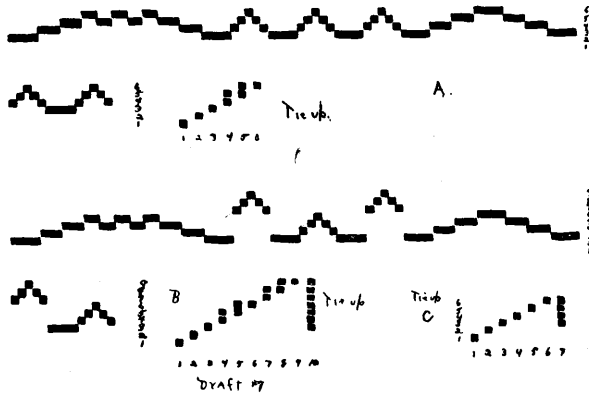

Treadling for No. 5B, tie-up at B. Two color overshot weaving.

Treadles 1 & 2 are used for tabby weaving.

3 green 8 times	5 purple 4 times
4 & 7 green 4 ..	9 green 4 times
8 purple 4 ..	4 purple 4 ..
5 green 4 ..	7 & 8 green 4 ..
9 purple 4 ..	6 purple 4 ..
6 green 20 ..	10 green 4 ..
10 purple 4 ..	4 purple 4 ..
5 green 4 ..	7 & 8 green 4 ..
9 purple 4 ..	6 purple 4 ..
4 green 4 ..	10 green 4 ..
7 & 8 purple 4 ..	4 & 7 purple 4 ..
6 green 4 ..	8 green 4 ..
10 purple 4 ..	6 purple 4 ..
4 green 4 ..	10 green 4 ..
7 & 8 purple 4 ..	4 & 7 purple 4 ..
5 green 4 ..	8 green 4 ..
9 purple 4 ..	5 purple 4 ..
6 green 4 ..	9 green 4 ..
10 purple 4 ..	6 purple 4 ..
3 purple 8 ..	10 green 4 ..
4 & 7 purple 4 ..	3 green 8 ..
8 green 4 ..	4 & 7 green 4 ..
5 purple 4 ..	8 purple 4 ..
9 green 4 ..	5 green 4 ..
6 purple 20 ..	9 purple 4 ..
10 green 20 ..	6 green 20 ..
	10 purple 20 ..

5 green 4 times	6 green 4 times
9 purple 4 times	10 purple 4 times
4 & 7 green 4 ..	5 green 4 ..
8 purple 4 ..	9 purple 4 ..
6 green 4 ..	4 & 7 green 4 ..
10 purple 4 ..	8 purple 4 ..
5 green 4 ..	6 green 4 ..
9 purple 4 ..	10 purple 4 ..
4 & 7 green 4 ..	5 green 4 ..
8 purple 4 ..	9 purple 4 ..
6 green 4 ..	4 & 7 green 4 ..
10 purple 4 ..	8 purple 4 ..
5 green 4 ..	6 green 4 ..
9 purple 4 ..	10 purple 4 ..
4 & 7 green 4 ..	5 green 4 ..
8 purple 4 ..	9 purple 4 ..
6 green 4 ..	4 & 7 green 4 ..
10 purple 4 ..	8 purple 4 ..
5 green 4 ..	6 green 4 ..
9 purple 4 ..	10 purple 4 ..
4 & 7 green 4 ..	5 green 4 ..
8 purple 4 ..	9 purple 4 ..

This same treadling draft is also used for the two-color double face or summer and winter weaving, but with the drawing-in draft and tie-up given at No. 5C, ground treadles 1 and 2 being used alternately with each of the pattern sheds given above.

The treadling draft for weaving the regular double-face type of weave in a solid color is given below, and is for use with the drawing-in draft and tie-up at No. 5D.

3 20 times	5 4 times
4 4 ..	6 4 ..

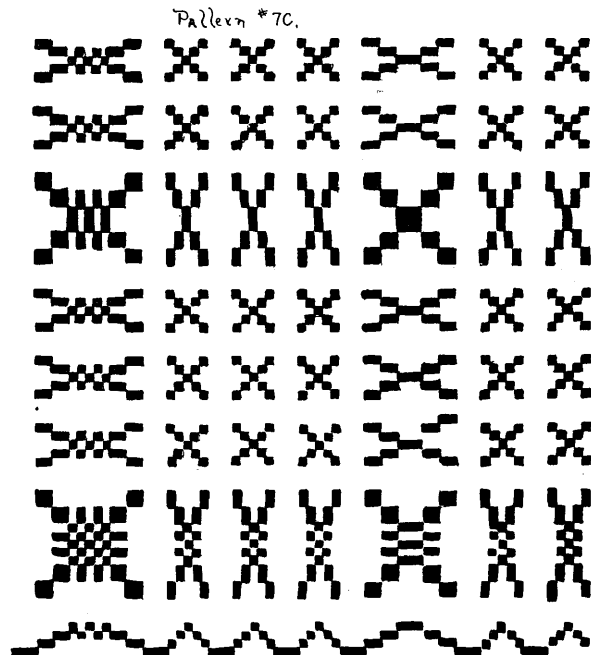

5	4 times	4	4 times
4	4 "	5	4 "
6	4 "	6	4 "
4	4 "	5	4 "
5	4 "	4	4 "
6	4 "	6	4 "
3	20 "	5	4 "
4	4 "	4	4 "
5	4 "	6	4 "
6	4 "	5	4 "
5	4 "	4	4 "
4	4 "	6	4 "
6	4 "	5	4 "
4	4 "	4	4 "
6	4 "	6	4 "
4	4 "	5	4 "
6	4 "	4	4 "
4	4 "	6	4 "
5	4 "	5	4 "
6	4 "	4	4 "
3	20 "	6	4 "

NOTE. — The above numbers are for the treadles for pattern harnesses only, and must be used alternately with treadles 1 and 2 to get a complete shed.

The treadling drafts given all produce the pattern effect that is shown in the illustration of No. 5 Speck Draft. The four-harness draft may be used with different treadlings, woven as "drawn-in" or sampler fashion; the resulting designs may then be developed in color. These and other arrangements may also be used for interesting effects on the double-face drafts.

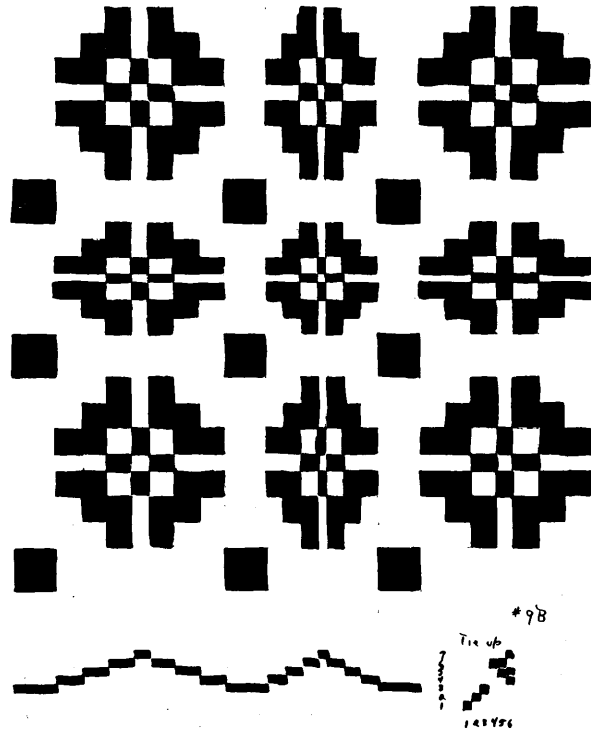

Draft No. 7. The drawing-in draft and tie-up for weaving this pattern in solid color in double face is given at No. 7A. The treadling draft is as follows:

6	4 times	3	8 times
5	4 "	4	4 "
4	4 "	5	4 "
5	4 "	6	10 "
4	4 "	5	4 "
5	4 "	4	14 "
4	4 "	5	4 "
5	4 "	6	4 "
6	4 "		

The treadling draft for a two-color effect with this pattern is given below and is used with drawing-in draft and tie-up at 7B.

6	brown	4 times	4	brown	4 times
9	orange		7	orange	
5	brown	4 "	5	brown	4 "
8	orange		8	orange	
4	brown	4 "	6	brown	4 "
7	orange		9	orange	
5	brown	4 "	3	orange	8 "
8	orange				
4	brown	4 "	4	brown	4 "
7	orange		7	orange	
5	brown	4 "	5	brown	4 "
8	orange		8	orange	

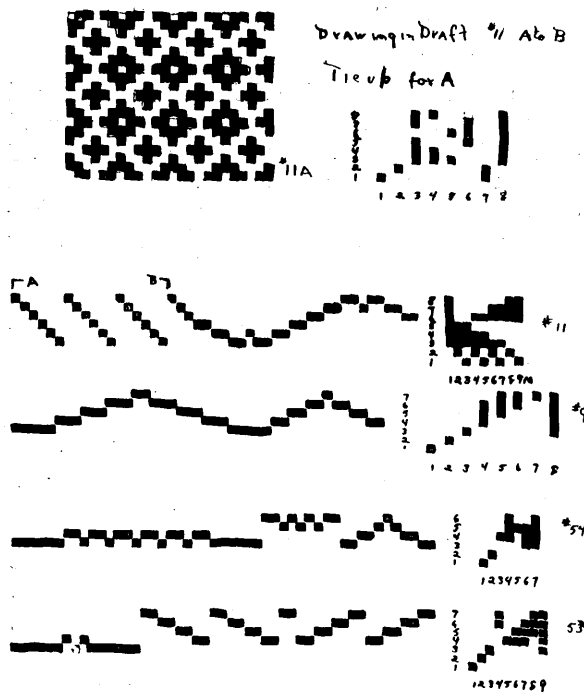

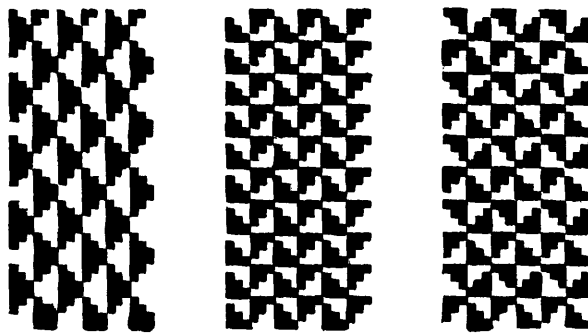

B

C

D

6 brown	4 times	5 brown	4 times
9 orange		8 orange	
5 brown	4 "	6 brown	4 "
8 orange		9 orange	
4 brown	4 "	3 orange	8 "
7 orange			

In weaving the double-face draft for this and the preceding pattern to produce the two-color effects, the method of splitting the sheds for the insertion of the colored weft is used. This was described in the July-August issue.

Illustration No. 7C is the draft No. 7 woven as drawn in.

Treadling for No. 7C. Tie-up No. 7B used for this draft also.

The ground weaving is inserted on sheds 1 and 2.

Treadles 1 and 2 against treadle 7 for plain or tabby weaving.

Ground	5	2 times	
weft	8	times	
4	6	"	
5	6	"	
6	2 or 4		
5	2	times	Ground
6	2	"	weft
5	2	"	8
6	2	"	4
5	6	"	2
4	6	"	5
			2
			4
Ground			Ground
weft	8	"	weft
4	2	"	8
5	2	"	4
6	2	"	4
5	2	"	5
4	2	"	4
			6
			8
			5
			4
Ground			Ground
weft	8	"	weft
4	2	"	8
			4
			2

5	2	times
6	2	"
5	2	"
4	2	"
Ground		
weft	8	"
4	2	"
5	2	"
6	2	"
5	2	"
4	2	"

Draft No. 9. The treadling draft to be used with the drawing-in draft and tie-up to produce the original pattern arrangement is given below. This is a double-face weave.

3	7	times	4	16	times
4	4	"	5	14	"
5	4	"	6	16	"
4	4	"	7	8	"
5	4	"	6	4	"
4	4	"	7	6	"
3	7	"			

Illustration No. 9B is a different suggestion for weaving the same drawing-in draft, but the changed tie-up as noted with the second pattern illustration. Treadled as follows:

3	7	times	3	7	times
4	4	"	4	2	"
5	4	"	5	2	"
6	4	"	6	2	"
4	2	"	4	1	"
6	4	"	6	2	"
5	4	"	5	2	"
4	4	"	4	2	"

It is possible to combine the original border and the pattern at No. 9B, thus making a center all over design as at No. 9B, with the border No. 9 across the ends and on the sides. This would be done much the same as the patterns with the pine-tree borders. Several more harness frames and a new tie-up would be required. To get the side border draft for No. 9, turn it sideways and bring down the blocks. Afterwards develop and combine the harness frames and tie-up so that the side border would be woven at the same time as No. 9B. In weaving, the regular draft for border No. 9 would be woven first and followed by treadling draft for No. 9B, repeating the No. 9B treadling draft the necessary number of times to fill in the center.

Draft No. 11. As noted in the previous article, there are quite a number of ways in which this draft can be woven, modernistic and otherwise. This is a similar draft to the familiar Cat Tracks, and can be woven as such, but for the few samples of this weave offered, the border A or B of the

original draft is all that is used. This is a straight twill draft and was enlarged four times for the patterns included here. Any of the common four-to eight-harness diaper and twill weaves can be similarly arranged for double-face weaving, and the weave effects obtained in the regular twills can be much enlarged with very interesting results.

At No. 11A is shown a diaper arrangement of the above suggestion; the tie-up is included, treadling draft below.

3	7 times	6	7 times
4	7 "	5	7 "
5	7 "	4	7 "

Repeat.

In the tie-up at No. 11 with the regular draft it will be noted that a double tie-up was used on an eight-harness ten-treadle loom, and with this tie-up only one treadle is used at a time in weaving. It is an easy matter to change the tie-up to a smaller number of treadles, but then two treadles would be necessary for weaving.

At No. 11B, C, D, are three patterns woven on the enlarged border draft and tie-up at No. 11.

Treadling for No. 11B

2	20 times	6	7 times
3		7	
4	7 "	8	20 "
5		9	

Reverse to beginning.
Treadling for No. 11C

2	7 times	6	7 times
3		7	
4	7 "	8	7 "
5		9	

Repeat.

Treadling drafts No. 11B and 11C make the treadling draft for weaving the whole pattern when the complete drawing-in draft at No. 11 is used, 11C being the border draft and 11B the treadling draft for the center part of the design.

Treadling draft for No. 11D

2	7 times	Woven from top to bottom, then reversed and woven from bottom to top. Each time that the direction of weaving is reversed, the order of inserting the colors is also reversed, i.e.: weaving down, use black for the pattern and orange for the ground; weaving up, orange for the pattern and black for the ground.
3		
4		
5		
6		
7		
8		
9		

Draft No. 53. Drawing-in draft unchanged, tie-up as given.

Treadling draft

3	10 times	7	6 times
4	2 "	8	6 "
3	2 "	5	6 "
4	2 "	6	6 "
3	10 "	7	6 "
5	6 "	8	6 "
6	6 "	5	6 "

Reverse.

Several interesting developments of this pattern may be made by using different tie-up and weaving drafts similar to Nos. 5, 7, or 9.

Draft No. 54. Tie-up for original method of weaving this pattern is given with draft. Treadled as follows:

3	12 times	3	12 times
4	2 "	5	4 "
3	2 "	6	2 "
4	4 "	5	2 "
3	2 "	6	4 "
4	2 "	5	2 "
3	4 "	6	2 "
4	2 "	5	4 "
3	2 "	3	2 "
4	4 "	4	2 "
3	2 "	6	2 "
4	2 "	5	2 "

Reverse.

This pattern may also be woven as drawn-in, as is shown at No. 54B, tie-up also included. Treadled as follows:

(Continued on page 38)

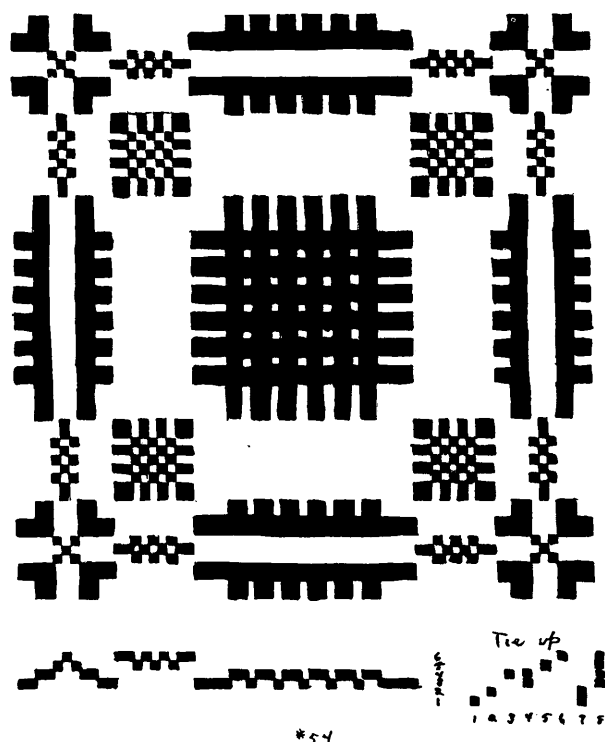

The Shuttle-Craft Guild of Hand-Weavers

THE Shuttle-Craft Guild is an organization of hand-weavers with members in all parts of the United States and many members in foreign countries. Included in its membership are college professors, housewives, army officers, teachers, artists, business people, writers, firemen, farmers, missionaries, doctors, — people living on isolated ranches in the Rocky Mountains and people living in New York apartments; in fact most of the different kinds of people to be found between lower California and the northern tip of Maine have representatives in the group.

The Guild was organized about seven years ago, with the idea of providing a meeting ground for people interested in the revival of hand-weaving, and to provide a center where those who wished to become weavers could obtain all available information. In the early days of the revival it was often very difficult for people living far from the large centers to get any help in this matter. There were not many people capable of giving the necessary information, and some of these, unfortunately, preferred to keep their knowledge to themselves. It seemed to the group who organized the Guild that this attitude was a mistake, and that if hand-weaving was to become once more a truly "popular" art we must make it easy for those who had the urge.

A common meeting ground has been the *Shuttle-Craft Bulletin*, a little news-letter sent out once a month to Guild members. Through the *Bulletin* many special activities are carried on, such as traveling exhibits to which members contribute articles made by themselves. These exhibits go from one to another, "round-robin" fashion, giving weavers an opportunity to see the work that is being done by others — a service particularly valuable to those

who live far from the large cities. Many such exhibits have been held, and there is usually one on the road. The Guild also from time to time publishes special matter of interest to hand-weavers. Some years ago the Guild — with the permission of the Pennsylvania Museum of Art — published the patterns contained in the old John Landes book of drawings, with drafts prepared by Mary M. Atwater. More recently the Guild has brought out

a little pamphlet of patterns in the new crackle-weave. The Guild also does a good deal of what may be called public service in the interest of the craft. A few years ago many of the leading magazines carried misleading advertisements of machine-woven products masquerading as "hand-woven." Most of this advertising we have been able to stop. One of the members, on behalf of the Guild, took up the matter with the Federal Trade Commission, and in the government's own good time we shall have an official ruling.

The Guild does not conduct a sales-agency for hand-woven products, though plans for such a service have been formulated and will be carried out when the membership so elects. However, inquiries often come in from people who wish to have coverlets or other articles woven to order, and these inquiries are referred to Guild members who are weaving for profit. And weavers who wish to find a sales-outlet are referred to the Guild members who conduct shops, — a service to both.

The chief aim of the Guild, however, is to raise the standards within the craft, so that hand-weavers will not be satisfied with mediocre work, but will produce only fabrics of excellent workmanship and high artistic value. A hand-woven fabric is not necessarily either good or beautiful simply because made by hand — if poorly woven and of poor colors



Leather mounted bag, "Queen's Delight" pattern, woven by Mrs. Charles Smith, St. Paul, Minn.



Fireside rug, "Summer and Winter" weave, Sunflower pattern. Pillow top and corner of rug "Wreath Rose" pattern overshot weaving Woven by Mrs. Eric Green, Providence, R. I.



Coverlet. Woven by Eleanor Foht, Fresno, California

or poor design it cannot compare with the beautiful machine-made fabrics in the shops, and may be simply a waste of time and good material. A successful piece of hand-weaving, however, is like a good etching as compared to a commercial "half-tone," or like a concerto performed by an artist compared to the rattle of a mechanical piano. There



The weaving studio of Emily N. Goodwin, Brooklyn, N. Y.

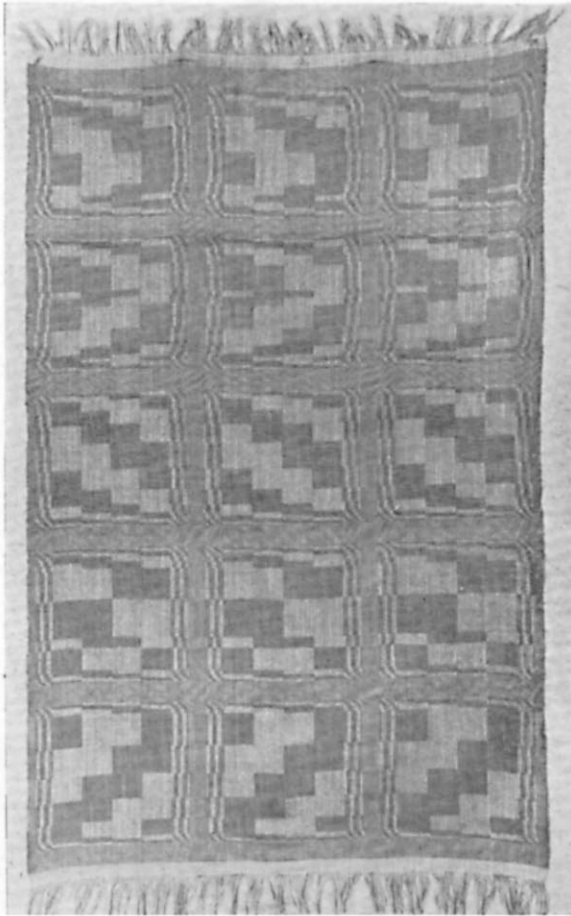

Wall hanging in modernistic style, crackle weave, "The Three Twills" pattern. Woven by Mr. Roger Millen, Hackerstown, N. J.

is a very real place for hand-weaving, — but it must be good hand-weaving.

In the beginning, membership in the Guild was limited to those who had taken or were taking the Shuttle-Craft Course of instruction. This was done to insure a common basis. At present, however, associate members are admitted to the circle in the idea of further extending its usefulness.

The Guild is very proud of the fact that so many of the people who are doing distinguished work in our craft are members of the Guild. Some are well known to readers of the *HANDICRAFTER*: Miss Glaser, who directed the work at the St. Louis School of Fine Arts and whose splendid exhibition was written up in the *HANDICRAFTER* some months ago, was one of the charter members, and so is Miss Ella Jurgens of St. Louis, whose fine work was shown in the same article; Mrs. Reed, Mr. Roger Millen, Mr. Hartz, Miss Fetterolf, Mrs. Nellie Johnson, Miss Davis, Miss Hall, and others whose articles have appeared in the *HANDICRAFTER*, belong to it; Miss Winifred Mitchell, who has made such a

splendid success of the Tenafly Weavers, is a charter member; Miss Winogene Redding, whose work in a southern mountain school was written up not long ago, Miss Goodwin and Miss Wolverton of New York, whose beautiful work has been mentioned in the *HANDICRAFTER*, — all these belong and many, many other distinguished weavers whose names ought to be mentioned but cannot be for lack of space.

Mrs. Atwater, who is the guiding spirit in the Guild, is a decorative designer by training — Chicago Art Institute, École Julian and École Calorossi, Paris, France; also she was designer for several years with the Winslow Brothers Co. of Chicago and later teacher of design in an art school. Her marriage to a mining engineer cut short her artistic career, but she began weaving fourteen years ago while living in the little mining camp of Basin, Montana, where she still makes her home. Having decided to start a "village industry" in hand-weaving at Basin, she purchased looms and obtained the services of an instructor. Most of the women in the little community came to the "Shuttle-Craft House" and wove. They soon had a flourishing little industry, exhibited work in New York and Chicago, and took many prizes. The war, however, intervened, and when the government

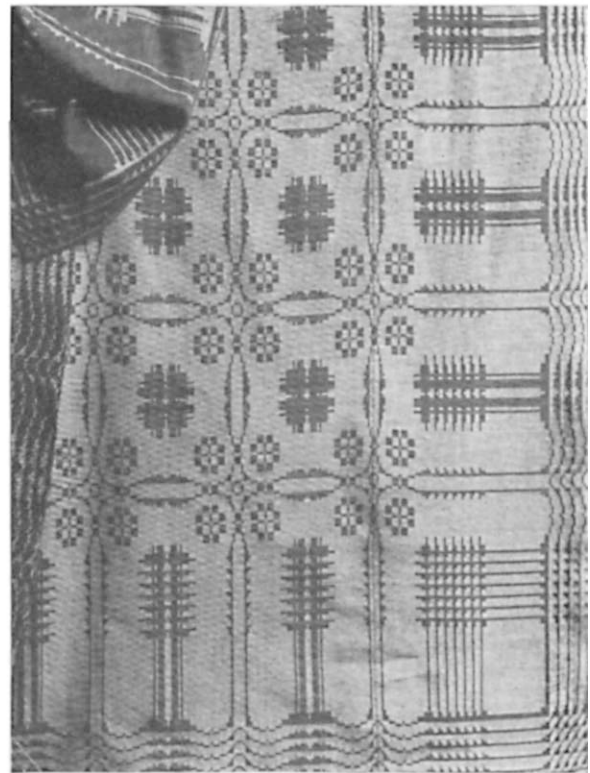

Coverlet, "Summer and Winter" weave, Snowball pattern with Pine Tree Border. Woven by Miss Virginia Shearer, Lewiston, Idaho

organized the reconstruction service and issued a call for women skilled in handicraft she enlisted and spent a year in army hospital service. After leaving the service she continued in occupational therapy for a number of years.

Later on Mrs. Atwater decided to have a weaving course and, with the generous help of Miss Grace Denny, in charge of the Textile Department, University of Washington, she "tried out" her course on a group of university students. These young people had never seen a hand-loom before. They were given the set of instructions and an empty loom, and their progress was closely observed. They came out very well indeed, without any help except what they got from the notes. In fact one of

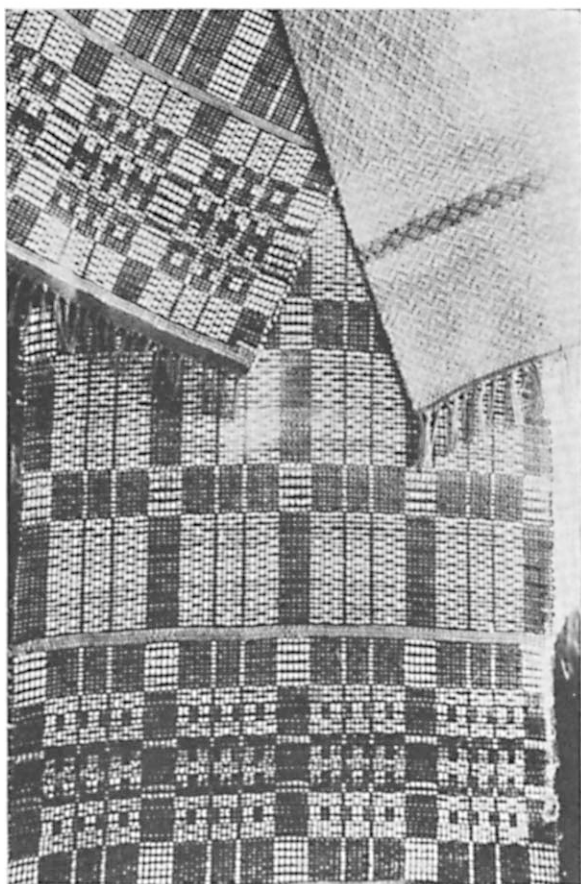

Unusual rugs in crackle weave. Woven by W. Clyde Dunbar, Arkansaw, Wis.

them "demonstrated" hand-weaving in one of the down-town shops at the end of a two-week session. She then offered her course to the public with some confidence, and since that time many hundreds of people have learned to weave, and to weave well, through written instructions and the criticism and correspondence that is part of the course.

Mrs. Atwater has devoted much of her time to questions of design, and it is through research work



Coverlet, "Summer and Winter" weave; pattern, "Lisbon Star with Pine Tree Border." Woven by Mrs. Shipley Brown

in museums and among old manuscripts that a number of the lost weaves of ancient times have become current again. "Double" weaving, widely advertised as a lost art, proved to be no such matter; the "Summer and Winter" weave, however, really appeared to be a lost art, and it was her work in experimenting on the loom and in deciphering ancient notes that finally unravelled the puzzle. The "Bronson" weave, too, was unknown among modern American hand-weavers till she dug it up, gave it a name, and set it going again. More recently she introduced to American weavers a very useful and little-known weave of Scandinavian origin, that through experimental work has given some very remarkable results.

NOTE. All the illustrations show work of members of the Guild.

Handweaving on Loom Frames

IN FOUR PARTS

BY CECELIA CLEVELAND WILLARD

PART TWO

The Kircher Loom

THE Kircher Loom is the second loom in this group, and devotees of the craft of weaving will welcome with great enthusiasm the introduction of this new loom fitted to the needs of beginners and yet so well constructed as to be far removed from the class of a toy.

The Kircher loom is distinguished by its adaptability to the production of a 2- or 3-yard length of fabric and by mechanical features usually found in more expensive looms. The relatively low cost of this useful little apparatus will recommend it to the use of craft teachers in schools and camps, to mature students making their first efforts in weaving with or without a teacher, and to persons who pursue craft work for its beneficial effects.

Many articles of small or medium size, up to 20 x 48 inches for example, can be practically as well made on the Kircher loom as on larger and more complicated ones. A thorough knowledge of two-harness weaving may be gained by the use of this loom without the aid of other equipment; indeed it answers all the purposes of an inexpensive weaving device.

Most small looms hitherto placed on the market are in the form of a frame, with notches at either end to hold the warp ends. With this type of loom the length of the web is limited to the size of the frame. Few such looms have a beater or an arrangement for raising the sheds.

With the Kircher loom it is possible and practical to put on a 2- or 3-yard warp. After the weaver has become thoroughly familiar with the apparatus she may get good results with a longer warp, but it is not advised in the beginning. Another advantage is the reed that raises both sheds and serves for a beater.

The loom is furnished unassembled. It can be set up by following the accompanying directions. If it is for the use of young children the assistance of an adult may be required in connecting the parts, which are only seven in number. Actual operation of the loom is simple enough to be easily mastered by a child of ten years. It will be found absorbing work for adults who wish to make experimental

first steps in weaving before purchasing more expensive equipment.

The entire loom is constructed of hard wood, very sturdy and is smoothly finished, so there is no danger of splinters for little fingers. It has been used extensively in Germany in schools and in home weaving.

To Assemble and Warp the Kircher Loom

The loom consists of four wooden pieces that fit together to form the frame, the wooden reeds, and two metal brackets to hold the reed in place.

The two narrow wooden strips are the sides of the loom, and they are marked 2 and 4 and 1 and 3 on the diagram. The wider pieces, with the wooden "combs" on the edge, are the back and front of the loom. They are marked 4 and 3 and 2 and 1 on the diagram. The sides and end pieces of the loom are plainly marked with the same numbers that appear on the diagram as an aid to assembling the frame.

First slip one metal bracket on the side piece marked 2-4, and slip it down to the first hole near the end marked "4." When the hole in the side of the loom and the metal bracket coincide, slip the metal pin through to hold it in place. Do the same with the other side, and secure the bracket in place at the first hole near the "3" end of the second side. Now take the end piece marked 4-3 and turn down the little wooden block screwed to the extreme lower left end; slip the end of the side piece marked "4" in the slot of the end piece marked "4." Now turn the block back in place. This will keep the side pieces from being jarred out. Slip aside the block on the right side of the end piece and place the end of the side piece marked "3" in the slot, and turn the block in place.

To Warp the Kircher Loom

The loom at this point is partially assembled. The two side pieces with metal brackets attached are fastened to the end piece marked 4-3. This is actually the front of the loom.

The warp is now made and wound on the back end piece marked 2-1, and the warp threads are threaded through the reed before 2-1 is joined to the rest of the loom.

Linen Weaver makes an excellent warp for experimental purposes, as it is stronger than cotton and not so elastic as wool. One tube of Linen Weaver is required to make a 12-inch warp, 2 yards long.

It is advisable not to start with too wide a warp, as quite a little experience is necessary before a wide warp can be wound on the loom at an even tension; 12 inches is a very convenient size for table mats, bags, scarfs and other small articles.

loop at either end. As our loom measures 20 inches and our warp only 12 inches, we must start fastening the ends of the warp to the back of the loom 4 inches from the right end marked "1." Divide the 12 threads into three groups of 4 threads each. Fasten the first group of 4 threads around one of the little pegs that are set close together across the top edge of the back of the loom. The threads are fastened by pulling 2 of the threads to the right of the peg and 2 threads to the left and tying in a



Illustration No. 1
Kircher Loom

Our 12-inch warp is made in 10 sections of 12 threads. Each section is wound by itself, and no "cross" or "lease" is necessary.

The warp may be conveniently made by winding a single thread around two pegs placed 2 yards apart, or around the backs of two chairs placed back to back, but not too close together, so that an approximate 2-yard length will result.

After a little experience some time will be saved by using more than one thread to wind the warp, but this would necessitate a spool rack, and it is a little more confusing than using the single thread.

Wind the first section of 12 threads and cut the

secure knot. Now push the threads down as far as possible with a nail file, or some other pointed instrument, so that it will not slip off the peg.

Take the next group of 4 threads and fasten around the next peg in the same manner. Then go through the same process with the last group of 4 threads in the first section of warp. We now have 12 threads in groups of 4 threads fastened securely around three of the pegs across the back of the loom.

The next step is to thread this section of 12 threads through the reed. It will be noted that this reed is formed by narrow strips of wood set in a wooden frame. There is a small round hole bored

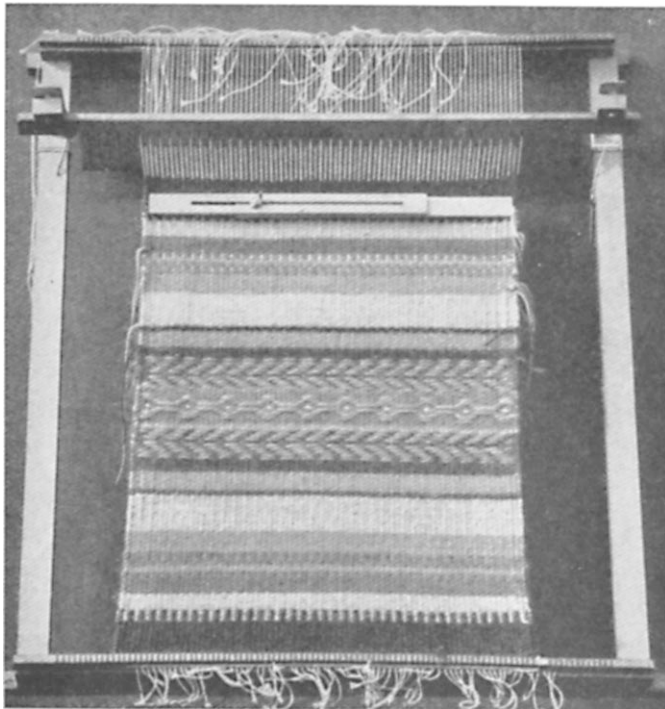

*Illustration No. 2
Another View of the Kircher Loom with Jalrie in Process*

in the center of each strip and a slit between every two strips.

The warp threads must be threaded first through a hole, then a slit, a hole and then a slit. The threads are pulled through by aid of a small wire hook.

Begin to thread the reed by starting 4 inches from the right end, making sure that the long end of the frame marked 7-8 on the diagram will come at the top of the loom.

Pull the first thread of the first group through a hole 4 inches in from the end of the reed, the second thread through the slit next to this hole, the next thread through the next hole, and the next thread through the slit. Continue in this way, alternating with the holes and the slits until the group of 12 threads are pulled through the reed.

Now pull the entire length of this group through the reed so that all the 12 threads are running in a straight line from the back through the reed. Secure this group with a slip knot.

Now wind another section of warp (group of 12 threads), fasten to the back and draw through the reed as before. Continue this until the 10 sections are fastened to the back and drawn through the reed.

Now untie the slip knots and, with the right hand, gather all 10 sections of the warp and pull firmly and evenly, so that all the threads are the same tension. Now hold the warp with the left

hand and comb the threads with the fingers and straighten out all snarls. Make sure all threads have been pulled through evenly. Now with the right hand wrap the warp around 2-1 (the end section) evenly by turning the entire end piece around and around. The first turn must be away from the weaver so that when the winding is completed, the threads will run from the top of the end section 2-1. (See Diagram 5.) It is important that the warp threads be wound on evenly and not in humps or mounds.

Wind until there is just enough warp to stretch across the frame and tie easily in the front. Now join 2-1 to the balance of the loom, and secure in place with the blocks. Place the long ends of the reed 7-8 on the metal brackets. Now tie the threads to the pegs in the front section in the same way as they were fastened to the back section, keeping in mind that in weaving all threads must go in a straight line from the back of the loom, through the reed, and fasten to the front beam.

Now start in the center of the warp and take the center group of threads, pull as tightly and evenly as possible, and tie in a secure knot around the peg, that is in a straight line with this group of threads. Take the next group of threads to the right, pull evenly and tightly, and tie to a peg in a straight line. It does not matter if some of the pegs are skipped over. The important part is to have the threads come to the front beam in a straight line. Now take the group of threads to the left of the center group and tie in a straight line to the front beam. Repeat until the entire warp is tied up and all the threads are taut and even. The loom is now ready for weaving.

The weaver should sit in a comfortably low, straight chair. The loom is held on the lap with the end 4-3 towards the weaver. The opposite end (2-1) is rested against a table at an angle where the reed may be comfortably reached for changing the sheds.

Weaving

The first or "A" shed (as the space for the shuttle to go through is called) is made by placing the reed on the wooden blocks of the metal brackets. It will be noted that half the warp threads (the threads through the round holes in the reed) are raised, forming an opening for the shuttle to go through. The second or the "B" shed is made by lifting the reed down from the metal brackets and depressing it. This raises the threads that were depressed in the "A" shed and depresses the threads that were raised in the other shed.

"Tabby" or Plain Weave

Put the loom in "A" shed by placing reed on the brackets. Wind a shuttle with a length of yarn, and put the shuttle through the shed from the right side to the left. The end is fastened by catching it around the end warp thread and drawing it up under about 3 warp threads. (See Diagram 3.) Now form the "B" shed by depressing the reed and putting the shuttle through from the left side to the right. Bring the reed down firmly to free the two rows close together. Put the loom in "A" shed again, and put the shuttle through from the right side to the left side. Press in place with the reed. Put the loom in the "B" shed, and continue in this manner. It is important to form the habit of making good, even selvages from the beginning. There should not be long loops left on the edges, but a worse and more common fault is to draw in the edges, thereby narrowing the warp. It is a good plan when putting the shuttle through the shed not to draw the thread in a straight line, but to leave it on a slant in the shed.

As the loom is warped with linen weaver, a luncheon set will be an excellent first project. For example, suppose we wish to weave a luncheon set consisting of six place mats and possibly a runner. The mats are woven first and then the loom is re-warped for the runner.

Make the first or "A" shed by placing the reed on the metal brackets. In the space thus formed, place a flat thin stick or a strip of cardboard 1 inch wide. Remove the reed from the brackets, and with it push the stick tightly against the front of the loom. Make the second or "B" shed by depressing the reed, and put in a second stick of wood or strip of cardboard and press it firmly against the first with the reed. These two sticks serve the purpose of bringing the warp end closely together and making a firm foundation to beat against.

Now make the "A" shed and put a shuttle wound with

linen floss through the opening from right to left and secure by going around the end thread and bringing the end up under 4 or 5 warp threads. Now lift the reed down from the brackets, bring it forward and beat the first row of linen firmly against the two strips. Next make the "B" shed, and put the shuttle through from left to right and beat in place.

Practice this until the motion of changing the shed, putting the shuttle through, beating in place, change, putting the shuttle through and beat has become thoroughly familiar. Care must be taken not to put two weft threads in the same shed, as an ugly streak will result. When about 2 inches of the tabby or plain weave has been accomplished, the border across the ends of the mat may be commenced.

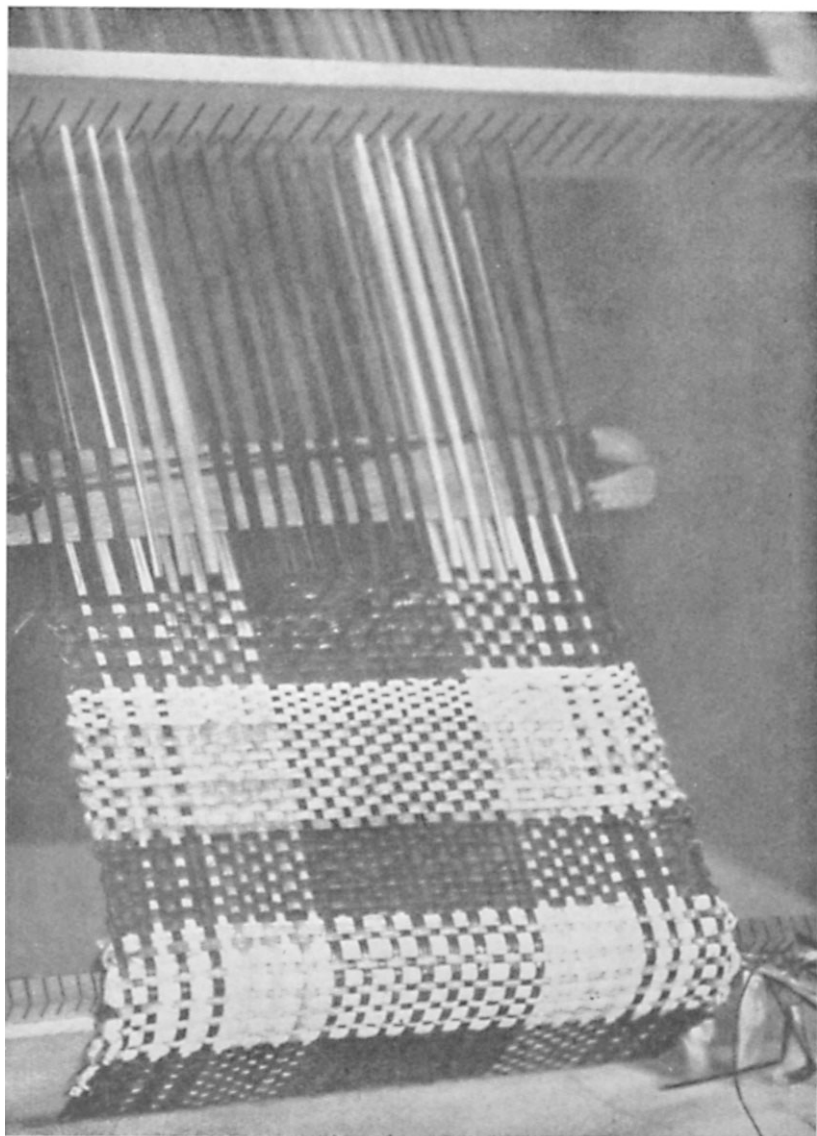

*Illustration No. 3
Carrying the shuttle through shed in Kircher Loom*

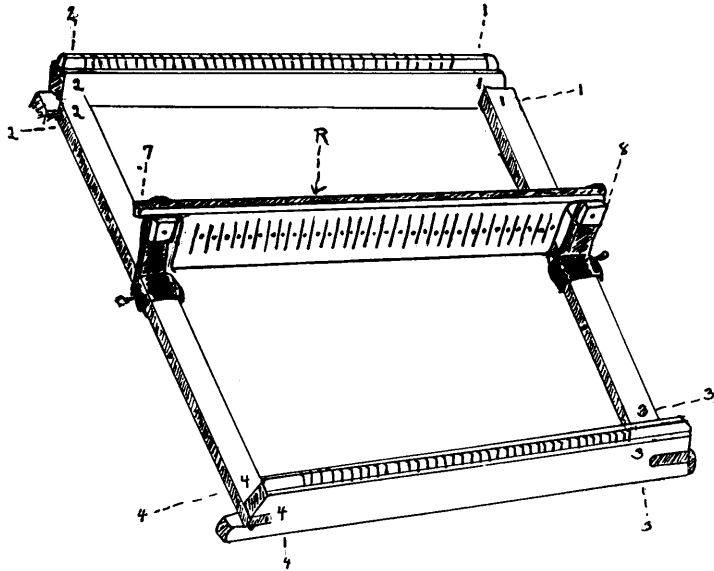

Diagram 4

Take a second shuttle and wind on it several yards of a contrasting color of linen floss. Green was used for the mat in the illustration.

End the white or ground color on the "B" shed, but do not detach it from the loom. Put the loom in the "A" shed, pass the green shuttle through the shed from right to left, and fasten the end around the last warp thread as before. Put the loom in the "B" shed, bring the white shuttle around the green thread and put it through the shed. (See Diagram 4.) Make the "A" shed and put the green shuttle through the shed. Make "B" shed and, after bringing the white shuttle around the green thread, put it through the shed to the left side. Make "A" shed and put the green thread through. Make "B" shed and, after bringing the green thread around the white thread, pass it through again to the right side. Make "A" shed and put in another row of green. (This makes 3 rows of green.) Make "B" shed and put the white shuttle through, going around the green thread. Make "A" shed and put in another row of green. Make "B" shed and put in a row of white. Make the "A" shed and put in another row of white. Make the "B" shed and put in a row of white. This makes 3 rows of white.

We now have a striped border consisting of 2 inches of white tabby weave for the beginning, 1 row of green, 1 row of white, 1 row of green, 1 row of white, 3 rows of green, 1 row of white, 1 row of green and 3 rows of white.

It will be noted, in putting in the stripes, that when the two shuttles are on the same side of the loom, the one that is then being

put through the shed must be brought around the other shed thread and then be put through the shed. This will insure a good selvage.

Now that we have our stripes we will add a center pattern. This little design is formed by alternating the green and white shuttles in the following manner:

- "A" Shed — Green
- "B" " — White
- "A" " — Green
- "B" " — White
- "A" " — Green
- "B" " — Green
- "A" " — White
- "B" " — Green
- "A" " — White
- "B" " — White

Repeat 3 times.

Finish the border by duplicating the stripes in the reverse order.

- "A" Shed — Green
- "B" " — White
- "A" " — Green
- "B" " — Green
- "A" " — Green
- "B" Shed — White
- "A" " — Green
- "B" " — White
- "A" " — Green

Many small all-over patterns and borders may be devised by varying the alternation of two contrasting colors. The two threads must be of the same weight and a decided contrast in color, or the effect will be blurred.

When the weaving approaches the reed so closely that it is difficult to get the shuttle through the shed, remove the metal pins from the brackets and push them down to the second hole. This will give more space. When this is also woven up the

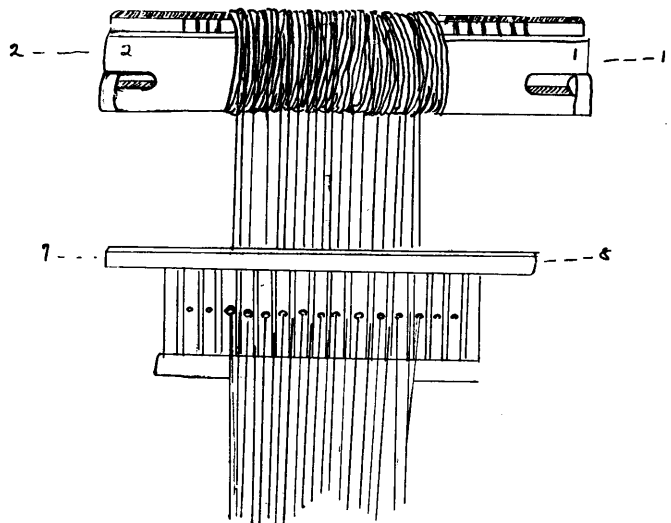

Diagram 5

Warp wound 2-1 and threaded through 7-8

brackets may be moved to the third and last hole.

After this space is woven up it is necessary to release the warp wound on the back beam and wind a portion of the woven material on the front of the loom.

First remove the reed from the brackets and allow it to hang loosely. Then push aside the two wooden blocks at either end of back beam (2-1), and pull the entire section out of the loom. Now unwind two turns of the warp and replace this section in the loom, taking care to match up the "2" with the "2" of the side piece 2-4 and the "1" with the "1" of the side piece 1-3.

Now push aside the two blocks on 4-3, and remove this section from the loom. Now wind the woven cloth carefully around the front beam in the same manner that the warp was wound around the back beam. Replace the front section 4-3 in the loom and put the brackets back in their original position, and put the reed in place. The loom is now ready to continue the weaving of a continuous length of fabric.

Errors

When the regular alternation of over and under, over and under of the tabby weave is interrupted by a vertical streak formed by two warp threads coming together, the trouble is the result of a mistake in threading the reed. An investigation will show that there are either two threads through two holes (without a thread through the adjoining slit), or there are two threads through two slits (without a thread through the hole between them). There is no remedy other than to rethread by starting where the mistake occurs and rethreading to the nearest end.

When there is a horizontal streak in the weaving this is caused by two weft threads going over in the same shed. To correct this it is necessary to "unweave" until the mistake is reached.

The Kircher looms come in three sizes, varying from 14 inches to 30 inches in width, and these looms can take about eight warp threads to the inch. They are suitable for school and hospital work, as well as for the individual.

A Traveling Exhibit of Hand Weaving

OF INTEREST to the weaver are the unusual exhibits of hand weaving that Mrs. Nellie S. Johnson of Detroit is rotating amongst subscribers. Though these exhibits are planned primarily for the bag weaver, craftsmen will find them valuable design and color harmony sources as well as a fund of suggestion.

The exhibits are comprehensive, as they contain finished bags, specimens of unusual weaves, drafts, treadling directions, and an assortment of bag tops. In the weavings Mrs. Johnson has included examples of her work as well as pieces of exceptional merit from other hand weavers.

Any craftsman strengthens her creative background by a study of the work of others; though one does not copy, the design structure and color combinations effected by ca-

pable workers helps in developing one's own. Also there is always the chance to secure ideas on texture structure through clever yarn combinations. As Mrs. Johnson is a weaver with a flair for the original, and has also been making a specialty of fine bag fabrics, the results of her experimenting are bound to be of value to weavers. To make the exhibits of practical value she has been explicit in directions on the fabrics included, giving information on yarns used and set-up of warp, as well as the pattern explanation. At all times revisions are being made

to bring the exhibits abreast with fashions and to show new weaves that are unusually good.

Craftsmen in isolated sections will find the exhibits valuable in their work, as it brings to their studios up-to-date examples of textures that can only be seen as a rule in the large cities.

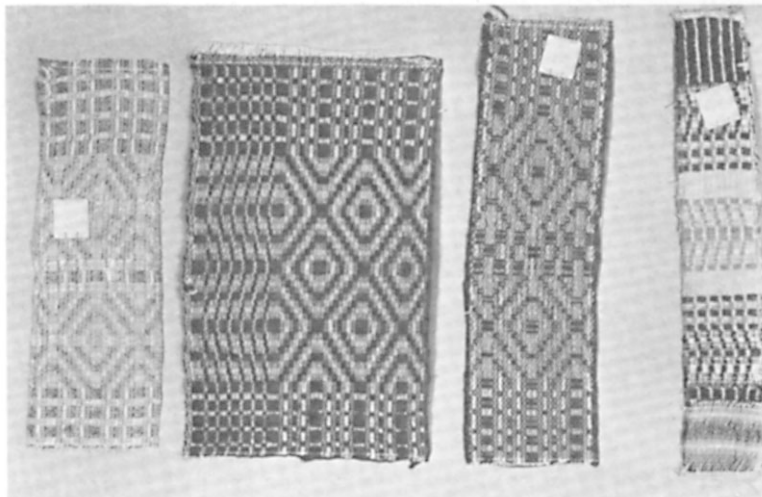

Attention! Boys and Girls!

MAKE YOUR OWN CHRISTMAS GIFTS

BY HELEN PERRY CURTIS

THE most thrilling thing about Christmas is getting ready for it! All the hurry and bustle, the whispering and plotting, the hiding away of suspicious-looking materials, the fun of almost being caught red-handed, the excitement of planning and then producing something that you have thought out yourself! And most of all the real thrill of giving a gift to someone you love, that has not just your money in it, but your effort and your imagination and your affection. If you go out and buy a ready-made gift, and go home and put it in your top bureau drawer until Christmas day, there isn't much of the real Christmas spirit about it. But if you begin to plan weeks ahead, simple things that may cost almost nothing, and you can make

yourself, just the right thing for each of your family and friends, you will find it loads more fun.

Here are a few gifts that other boys and girls have made. (And I don't mind telling you that grown-ups like to make them, too.) You may want to experiment by copying one or two of them first, but after that you will want to make your own designs and carry out your own ideas. These are just suggestions to get you started. You have no idea how much fun it is when once you get going.

First of all, you need a place to work. You may have an impromptu workshop in your cellar or garage, or may fix up a corner in your own room or your schoolroom. Be sure to have a lot of old newspapers to protect the floor or table, an old rag

for paint and glue, and a smock or apron to cover your clothes. Then get together the materials you need for each job.

Everybody loves to paint, and in every household there are tin containers and glass jars of one sort or another to be found. The accompanying illustrations show three or four delightfully simple and inexpensive ways of combining paint and containers to make colorful Christmas gifts. The only

necessary equipment is a one-inch flat brush, a small brush for making fine lines, and two or three cans of enamel, perhaps including one of gold or silver gilt. You should also have a bottle of turpentine, for thinning paint or cleaning brushes.

The vase (Fig. 1) is made of a large glass jar which was

originally full of strawberry jam. It is painted a lovely soft blue, using a dull rather than a shiny paint in this case. After it had completely dried (sometimes this takes only a few hours, sometimes a day or two, depending on the kind of paint used), it was stippled over with a stiff-bristled brush dipped in rather dry silver gilt. The stippling must be done very carefully, and it is well to try out the brush each time on a piece of paper before using it on the base, so that there may be no unexpected blots or blotches. If this were filled with bayberries, the branches of which had been painted bright blue or vermilion, leaving the berries the natural silver-gray, it would make a lovely all-winter decoration, which would please mother immensely as a gift. Another glass jar might be painted Chinese vermilion, and filled with small branches of fine-



Figure 2
Tea Caddy

Figure 3
Decorated Box

Figure 1
Flower Vase

leaved pine, with small cones touched at the tips with the same vermilion lacquer. Jam jars with screw tops may be interestingly painted, and filled with home-made candies. You will find your pantry full of delightful possibilities in the way of empty containers just longing to be transformed into jolly gifts.

The tin tea caddy with a cover (Fig. 2) was enamelled a shiny Chinese vermilion. In using this enamel it is necessary to work rather quickly, making the brush strokes all go the same way to assure a smooth finish, and any covered tin should be painted with the cover on, or in such a way that no paint touches the part that the cover slips over. After the enamel was dry, a simple design of lines, scallops and dots was put on with a fine brush. This was done free-hand, and the dots were of varying sizes. The box was then filled with stuffed dates, which anybody can make, and the result was a gift that was beautiful, not only for the Christmas season, but all the year round. Such a box is always useful for candy, salted nuts or small cookies.

The next box, a round flat one (Fig. 3), was covered with black enamel. The design used on the top was a conventionalized rabbit adapted from an old Persian plate, and was carried out on the black background in blue and silver with a few touches of Chinese vermilion. Such a box might be filled with Christmas cookies and later used for bonbons or buttons. A circle, any circle, presents a wonderful opportunity for design. If you have one to work out, draw several circles the right size on paper, and experiment with different types of design, using flowers, animals or geometric figures. It would be interesting first of all to study plates, architectural motifs and other types of design enclosed in circles. You may take your inspiration from Indian, Oriental or European peasant fabric, pottery or decoration. The only difficulty will be to stop drawing



Figure 4. Box with Decorated Paper Cover

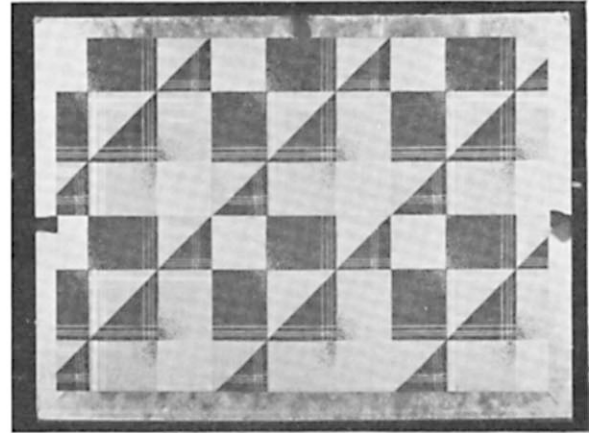

Figure 6. A Large Portfolio Bound in Paper

pictures in circles, and get down to business with your paint-brushes. There are any number of other sorts of tin receptacles in the kitchen cupboard, covered cans that are short and fat, or tall and thin, that crackers, cookies or coffee have come in, any of which may be charmingly made to hold Christmas goodies, and put to other uses for the rest of the year.

Delightful things may be made of paper and glue, too, and with a little patience and ingenuity you can produce all sorts of unexpected gifts for the family, from a box to hold small brother's collection of pebbles to a desk set for father. For this work glue is more satisfactory than library paste, and most paper-covered articles are improved by a final coat of white shellac, when the article is finished. A shellacked paper can be dusted or even wiped off with a damp cloth, so that it is much more practical than a plain paper.

There are a dozen kinds of paper that may be interestingly used for this kind of work. Left-overs of wall paper, Christmas wrapping paper, Japanese and Italian bookbinding paper, brilliant colored bits from the inside of lined envelopes, decorative prints from magazines, almost any kind of paper which is gay in color and jolly in design. You should have a one-inch flat brush for the glue for the bigger articles, and a separate brush for shellac. Any number of things may be covered with paper; boxes, books, portfolios, lampshades, wastebaskets, hatboxes and so on, *ad infinitum!*

The box shown in the illustration (Fig. 4) is made of one of the finer cigar boxes which has a cover that turns down around the edge. The box was covered in a Scotty wrapping paper in black and white,



Figure 8. Bag in Appliquéd Felt

and lined with a Chinese valentine of bright vermilion with a gold medallion on the under side of the cover. As the Scotty design had a distinct up-and-down, the paper had to be carefully cut so that all the dogs should be sitting up instead of standing on their heads. This necessitated cutting separate pieces of paper for the top and each side of the box, and putting them on one at a time. Sometimes the whole box may be covered with only two pieces of paper, one for the cover, and one for the box, by folding the paper carefully around the box, cutting out the corners, and gluing each side as you come to it. The glue may be put on the paper or on the box, as you prefer. All edges should be cut wide enough to overlap and turn under when necessary. It is easy to snip it off as you go along, but hard to make it bigger! The shellac may be put on while the glue is still wet, as it helps to hold the edges down. Wooden boxes such as candied fruit comes in, or stiff cardboard boxes, make handy receptacles for sister's necklaces or mother's sewing things.

A magazine cover or portfolio make acceptable gifts for almost any member of the family. The cover should be cut a half inch larger all around than the magazine it is intended to hold. The foundation should be made of firm cardboard, and the back strip is made

by cutting off an inch-wide piece from the left-hand edge of the cover. The illustration (Fig. 5) shows how this back strip is covered on both sides with a piece of gummed linen, and connected with the main part of the cover, leaving about a quarter of an inch between the two pieces. Both sides are made in exactly the same way. A wall paper with rather a modern design was chosen to cover the outside. The paper was laid with a straight edge about an inch and a half from the flexible side of the cover, and a half inch was allowed on each of the three other sides for turning over. This was then glued on and the corners cut out to make a neat finish underneath. Another wall paper, pale blue, with silver stars, was cut an eighth of an inch smaller than the inside of the cover, and glued on. Then the whole was shellacked, in this case giving a rather charming striped effect, as it was a water-color paper, and the color ran a little under the brush. Holes were punched in the back of the binding, and the two sides tied together with a cord. This particular binding was made to fit brother's Nature magazine in which proper holes were punched each month to make them fit the holder.

The big portfolio (Fig. 6) is suitable for sketches or a picture collection. It was made of very heavy cardboard, each side about eighteen by twenty-four inches, but it could be made in any size. A narrow strip of the same or somewhat lighter cardboard, about half an inch wide, runs down the back.

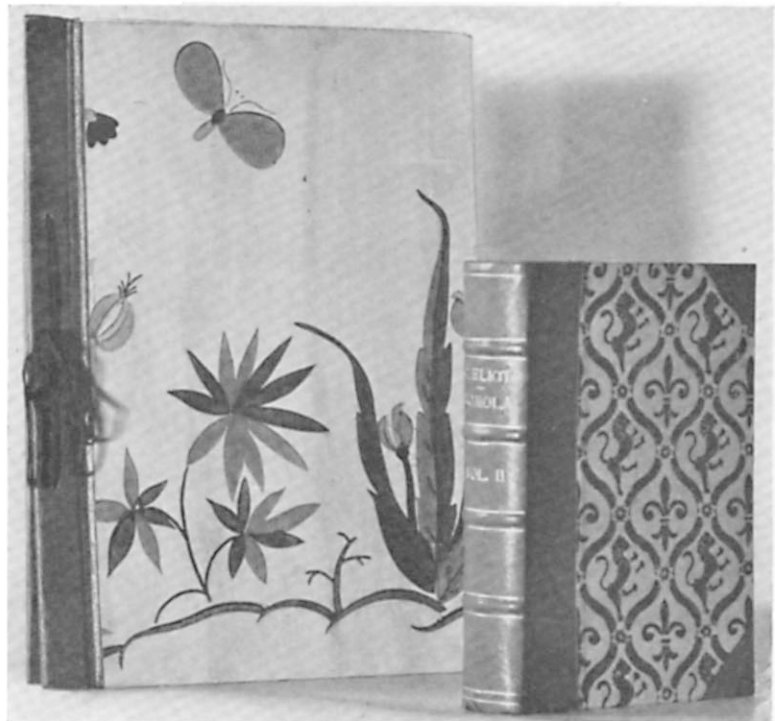

Figure 5. Portfolio with Wall-Paper Cover

Figure 7. Book Bound with Leather and Decorated Paper

This strip is held to the two sides with a piece of gummed linen, leaving about a quarter of an inch between, for the bend. A similar strip of linen is glued to the under side, making the back extra strong and flexible. A large piece of silver paper is used to line the covers, extending over the right side for an inch and a half on the three outer edges, with neatly mitred corners. If your piece of paper is not large enough, it may be neatly pieced, with the pattern matching. An extra strip of the silver paper, an inch and a half wide, runs down the back edge of the cover, next the linen binding. The outside is covered with a black and vermilion and silver paper in modernistic design, cut an inch smaller than the cover, so that the plain silver paper frames it all around. It is tied with black ribbon.

A quite ordinary book, in a plain cloth binding, may be turned into a charming gift with the addition of a lovely Italian paper put on over the original cover (Fig. 7). Lay a straight edge of the paper about an inch from the back-binding, and trim off the other three edges to fit the book, allowing a half inch to turn under. Crease the corners back so that each side of the corner triangle measures an inch and a half. Cut off at the crease. Put the glue on the paper in this case, being careful that it is not too thick at the edges, so that it will not run out and spoil the original book-binding. When the cover has been smoothly pasted on, open the book and cut an end-paper that will cover both the inside of the binding and the front page, allowing enough to push firmly into the fold of the binding. Glue this on carefully, and trim. It is a good thing to put a piece of extra paper under the front page, until the glue is dry, so that it will not run into the edges of the pages. A coat of white shellac over the outside of the book will give it the look of a lovely old volume, of which anyone might be proud.

Hatboxes may be covered with scenic wall paper to look like the old ones. The medallions should be chosen so that they will come in the center of the front, back and top of the box. Or a plain calico wall paper may be used, with an old print or any gay picture on the top of the cover. A coat of shellac will make it more practical, and mellower in color. Plain wastebaskets may be bought and covered with wall paper in a large design, or a finely-figured paper with the addition of an interesting picture or print. When you have once started covering things with paper, you will find any number of fascinating

things to make, and you will develop considerable ingenuity in cutting patterns and making neat finishes.

Another medium that is delightfully easy to work with, and colorful in its possibilities, is felt. This comes in many gay colors, and the fabric is firm enough so that it may be used for appliqué without turning the edges under. Both children and grown-ups love bags of all sorts, and every member of the family could use one for something or other. All sorts of interesting handles can be bought or made, and as a gift, a bag is sure to be satisfactory.

The first bag illustrated (Fig. 8) was made by a child of ten. She drew her own design of two very modernistic deer and some colored circles, and transferred it to a piece of bright-blue felt. Then she chose shades of felt in beige, yellow and fawn for the appliqué. She planned the bag to fit a ten-inch zipper. These zippers come in various lengths and make a simple and inexpensive closing for a bag. After the felt appliqué was cut out and sewed on, the bag was stitched up the sides, turned and sewed close enough to the zipper so that only the metal part showed. The handles were made of two-inch strips of felt folded in the middle, stitched a quarter of an inch from the edge, and turned with a safety pin. The ends were then cut in a point and sewed to the sides of the bag. The whole was lined with beige satin, sewed once near the metal part of the zipper, and again about a quarter of an inch from the metal so that there is no danger of the zipper catching in the lining.

The next bag (Fig. 9) was made of light brown felt, with a dark brown Scotty appliquéd on. This was closed with a six-inch zipper, and a finger-loop attached near one corner to carry it by, finished it off properly. If you happen to be a boy, and do not like to sew, make this bag of soft suede leather, with the Scotty pasted on, and give it to father for a tobacco pouch, or to little brother for his marbles. Perhaps some kind soul will sew it on to the zipper for you! All sorts of jolly bags may be designed, using felt or leather, with flowers, animals, or geometric modernistic decoration.

After you have experimented with a few of these gifts for your family and friends at Christmas time, and find out how easy it is to make them, I am sure one of your New Year's resolutions will be to make a lot of them for yourself during the coming year.

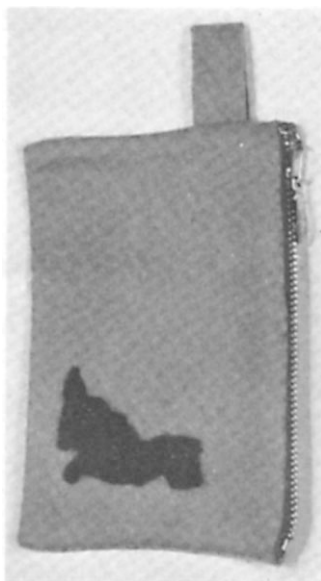

Figure 9.
Bag in Appliquéd Felt

The Pros and Cons of Fly-Shuttle Weaving

BY FLORENCE B. CATHCART

IS fly-shuttle weaving to be classed as hand-weaving? As our cautious lawyer friends answer, yes, and no. A fly shuttle in the hands of an intelligent weaver, using the same care to distribute the amount of weft necessary to produce good edges and to lay in the desired number of picks to the inch, produces cloth which cannot be distinguished from that made with a hand-thrown shuttle. In the hands of a speed-mad operator, whose chief thought is of daily yardage, material may easily become flat and uninteresting in appearance. It loses the qualities which give a surface varied enough to produce differences in light reflection. This does not mean differences large enough to be noticeable and amounting to flaws. Care-

less weavers sometimes rationalize these flaws as proofs that the material is hand-woven. Such flaws as "streaks," which are picks beaten too closely, and "spaces," or picks not beaten closely enough, are legally sufficient cause for the refusal of material. They occur in power woven material when the machinery gets out of order. They are quite as much a proof of the inefficiency of the human weaver.

Let us examine a foot-power loom equipped with a fly shuttle and see how it differs from one requiring a hand-thrown shuttle. The beater, which may

swing from above, or pivot from below, has a strip about two inches wide fastened in front of the reed and on a line with its lower edge. This strip, called the shuttle race, must incline slightly backwards, so that gravity will assist in keeping the moving shuttle on its support. At each end of the batten the race ends in a shallow box, just large enough to hold the shuttle without friction. Grooves in the sides of the box near the top support a square of wood, called the picker, which has hanging from it a leather loop. To the picker is fastened a rope which runs up and through a small pulley attached to the super-

structure of the loom and near its side supports. The two ropes, attached to the pickers in the boxes, meet in

a handle in the center. The ropes are long enough to allow the shuttle to reach the end of the box into which it is being thrown. The right hand holding the handle gives a quick pull, which causes the shuttle to fly through the open shed and lodge in the

leather loop of the picker in the opposite box. Here it is held while the beater is pulled forward, distributing the weft and battening it into place. The foot seeks the next treadle, the batten swings back and all is in readiness for the throw in the opposite direction. Sounds easy? But it is much more difficult than a hand-thrown shuttle. Time, not strength, becomes the determining factor, and movements must be under conscious control. Coördination between foot, shuttle-hand, and beater-hand must

(Continued on page 38)

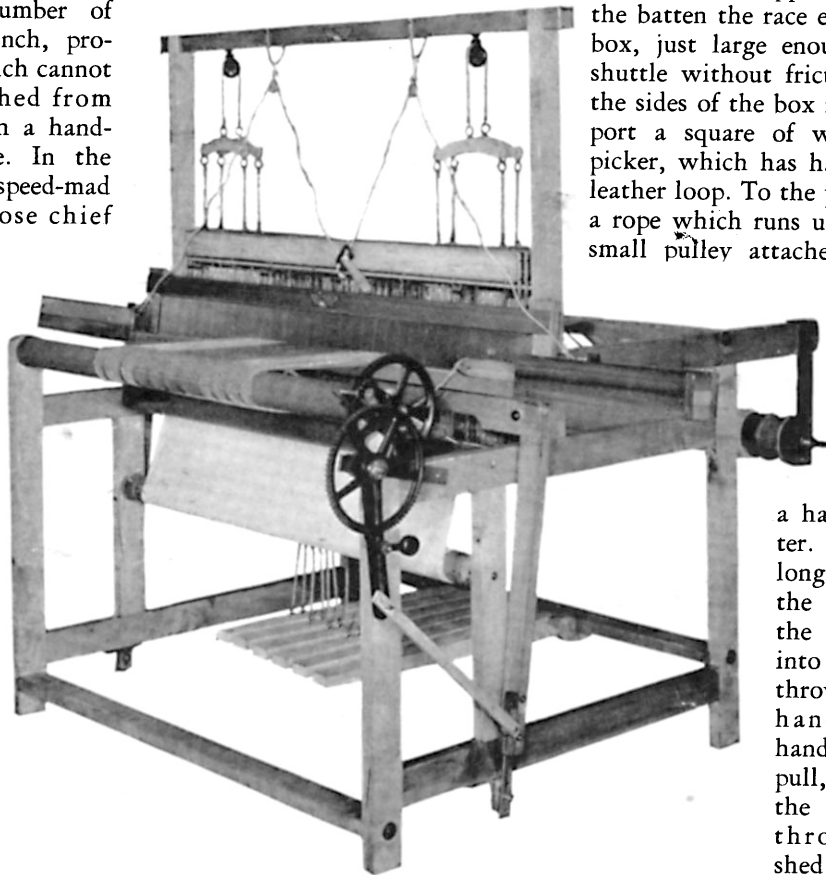

Block Printing Your Own Christmas Card

BY M. LOUISE ARNOLD

IF YOU have never made your own Christmas card, but plan to do so this year, you have before you a bit of work, some moments of concern, and a very great deal of pleasure. The individual card has become very important and, notwithstanding the beauty of the present-day commercial cards, the ones we hover over and call attention to when holiday groups gather are those designed and made by the senders themselves. And though you start with high hopes for a professional-looking job, remember that the charm is in the individual idea, the personal rendering.

Wood engraving, because of its great technical demands, is decidedly a craft for the skilled artist; but soon after Battleship linoleum was put on the market it was discovered to be an excellent substitute for the wood block and one easily handled by amateurs. More-

over, since it has its own fine points and limitations, the linoleum cut has come to have a certain standing of its own.

Battleship linoleum may be bought in any furniture store. Since it comes in a width of six feet and is fairly expensive, it is a good plan to inquire about scraps. Many dealers have pieces left from flooring jobs, and these can be had for very little.

Almost every art supply house carries some type of linoleum engraving tool, but as many of us hesitate to stock with tools for an untried trick, and since in our enthusiasm we may hate to wait, we will find a safety razor blade of the variety with one bound edge a very satisfactory tool. The double-edged blades will not do so well, since they have not sharp corners, and break easily.

Now for our design. First, as children say, we must "think of an idea." The old notion that Christmas cards must consist solely of Santa, fireplaces and holly has quite gone into the discard. In fact there is scarcely a subject which, if happily presented, will not make a suitable greeting. You may be sufficiently frivolous to use a jumping jack, or a snow man; a tiny flower pot may blossom in huge geometric flowers; or if you are feeling dignified a print of your favorite church tower may be used, or perhaps a little cut of your own door-

way to carry a seasonal note of hospitality.

Whatever the motif, it must be borne in mind that linoleum is a material which demands simple interpretations. Delicate lines and finely drawn spaces have no place with this medium. Make a few rough sketches on paper. Go over these with brush and ink.



This will help to eliminate the too fine areas. Use plenty of black masses. When the white spaces are too great it gives an impoverished appearance to your design. And remember in planning the darks they can always be cut out as the work progresses, but they just can't be cut back in again. If you must have fine lines let them be white lines in black spaces, since they are much easier to cut. Grey areas may be obtained by lines of light and dark.

There are two reasons why lettering may well be omitted. First, your print, without the words of seasonal greeting, may be a pleasant bit for a friend to keep, even to pin up on the wall. One of our professional printers said recently that she found it bad for her morale to make cards to help fill the wastebasket of the New Year. She now puts out



charming little prints which, because of their variety of subjects, are treasured the year through. In the second place, the printing, unless very well done, may detract from an otherwise attractive card, since discrepancies in the familiar letter forms are more noticeable than anywhere else. However, if you feel up to it, use a simple block letter, and don't fail to reverse the word or phrase. Examine the printing before a mirror before cutting, to be sure that all letters are reversed. Keep the letters thick and rather crowded. Otherwise they will seem sparse and weak when printed.

Now draw the design, or trace it with carbon paper onto the linoleum block. The paper may be fastened down with thumbtacks or pins, placing them in the light spaces. It will be easier to cut if the darks of the pattern are inked or blackened with pencil on the block itself. If you do not do this, keep your drawing at hand while cutting.

Holding the razor blade at a slight angle, cut along the dark edges, not very deep, and slanting away from the dark. This will leave the base of the darks wider than the top, and there is less danger of breaking the block in printing. Now cut along the dark lines, but a little away from them, about a sixteenth of an inch, and slanting this time toward the dark. Peel out the thin strip of linoleum next to the dark areas. You now have a clean edge for the printing, and the white areas can be cleaned out with less danger of nicking the dark edges. The white areas can be cleared by cross-cutting and

digging out the bits of linoleum. Many beginners make far too much work of this by digging too deeply. It weakens the block to do so, and is unnecessary. The small light spaces may be quite shallow, the larger ones a little deeper. In all probability you will have to clean out some flecks after a trial printing anyhow.

When the cutting is finished you are ready to make your trial print. Printers' ink may be used, and a small portion secured from your local printer will, when thinned with gasoline, go a very long way. If color is wanted, oil paints, thinned with a little linseed oil and gasoline, are good. Poster paints may be used with a bit of glue mixed in for body. Transparent water colors may be used with a little more glue, and India ink with glue is also satisfactory.

Any of these may be applied to the block with an ordinary brush. Brush up and down, then across the block to secure a smooth coating. The most satisfactory way, however, to apply the ink or paint is with a printer's roller or brayer. If your printer is very good-natured and properly approached, he may lend you his roller. For this process, the ink or paint should be rolled out thin on a piece of tin or



glass. Before rolling the ink on the block, pass the roller over a piece of scrap paper to take off excess ink. Now roll on the block crosswise, then lengthwise. Several rollings are necessary to ink the block the first time. The ink should be spread thoroughly but thinly, otherwise a greasy effect is created. It is almost impossible without a printing press to obtain a black without a great quantity of ink or paint, and since the texture is of more importance than the tone it is best to try for a deep even grey.

Now to print. Almost any paper which does not

have a too slick or too rough surface can be used. Ordinary drawing paper is good; certain wrapping papers are fun; Japanese rice paper makes soft, lovely prints, and if you like you can print on color. Black shows up best on cream, yellow and orange papers, though cool, snowy-looking prints result from using pale blues and greens.

It is possible to make prints by laying the inked block face down on the paper, with a thick soft pad of cloth or newspapers beneath and pressing very hard. If the paper you are using is very thin it may be laid on the face of the block and rubbed with the soft part of the hand. Far better prints will be obtained, however, with a letter press such as many offices have. A pad should be used with this also, the inked block slipped in as nearly under the center of the screw as possible and the wheel turned down. A piece of wood should be placed over the linoleum if the block is large, to insure distribution of pressure. Many people like to tack or glue the linoleum to a wood block to save placing the wood each time. A few trial prints will be necessary to find the right amount of pressure. Too much will



M.E. Gaurch South

Lois Clark

burst the paper; too little will leave a pale splotchy print.

Another device for printing, and one equally good, is an ordinary wash wringer. Set the screws far enough apart to carry the thickness of the linoleum. No pad is needed here, but two narrow strips of linoleum, longer than the block, should be inserted between the wringer rolls at either end. As these start before and finish after the block goes through the "pinch" mark at either end of the print will be avoided. Start your paper through; place the block against the rolls and turn slowly and evenly. Reach over the wringer and hold the block as it comes through, so that it does not smear the print, letting the paper fall free. Here again a little practice will indicate the desired pressure. It is best, whatever your method of printing, to use paper a little large and trim margins to fit the print, rather than try to locate a particular spot with a wet block. When one good even print has been secured, look for background bits that need cutting out. Sometimes accidental flecks add to the texture and may be left with good effect. Leave wet prints spread out until dry.

The printing process will be much easier if you have a supply of old newspapers to protect tables,

(Continued on page 39)

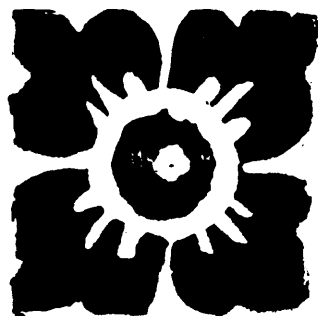

Silver Bookends and a Bracelet

BY MARY ANGOOD

SILVER! What magic there is in the word and what a vision of smooth, gleaming surfaces. All the joys of working with this fascinating metal, with its countless reflections of light and shade, may be experienced by even the most humble craftsman. That thrill felt by the silversmiths of long ago may inspire again the modern workman.

As pewter provided an inexpensive substitute for the early American artisan, so does the ordinary German silver, such as is used in the making of name plates and advertising signs for business houses, supply the craftsman of today. This metal possesses all the soft sheen and glowing color of pure silver, and is equally suited to the technique of the ultra-modern designer or that of the more conservative one. It is easily handled and at the same time durable enough to warrant the expenditure of considerable time and energy upon each piece. As in all craft work of real merit, the worth of the finished article depends not so much upon the value of the materials used as upon the knowledge and skill of the artist.

Design, that elusive quality which distinguishes the actual work of art from a mere handmade object, is of prime importance and, although the desire to begin on the metal at once is almost irresistible, it is much better to devote considerable time to the question of suitable decoration. Corrections in pattern are easily made upon the paper before the work is started on the metal, but are usually difficult, if not impossible, afterwards.

Because of the ease with which this material is handled and the few tools required, the work is as well adapted to a large class in the ordinary schoolroom as to the individual worker. The articles in the illustrations were made by members of a high school art class all of whom had had considerable experience in designing but none in metal work. Although there are many simple objects which may be made in any schoolroom with a reasonable amount of equipment for metal work, the bookends

and bracelet were made with the most common of tools. In addition to the metal, which was purchased in sheets cut to the approximate size of the different patterns, the following materials were used: a bottle of hat dye (any color); a half pound of nitric acid (chemically pure); a cheap water-color brush (medium size); a ball of etching ground (hard); two large but shallow pans or dishes, one of which should be glass or porcelain; a large soft blotter; a file and a dozen saw blades. The pans must be large enough for the metal to lie flat on the bottom so that the acid will eat evenly. The file should be fine and of good quality; a small triangular one may be bought at any jewelry supply house, where the files may be found in bunches of a dozen for about twenty cents a bunch. Of course they are to be used in a holder, which may be bought at the same time. A small vise, which may be found in any ten-cent store, is a great convenience in



Silver Bracelet designed by Louise Serrez, a pupil of the author

holding the metal securely while sawing. The etching ground, purchased from any art company carrying etchers' supplies, should be wrapped in a small piece of thin silk, as illustrated in the sketch. Liquid ground is easier to use in some ways, but is more likely to chip in the acid bath. A little salt and vinegar, some old soft cloths for cleaning the metal, and a little pumice and silver polish for the finished pieces complete the list.

The three pieces illustrated show three different styles of pattern development: the bracelet, a fine line design; the tree pattern, a combination of raised and lowered surfaces with no lines; and the horse, raised and lowered surfaces with line decoration upon the raised parts.

The bracelet consists of alternating bands and triangles, the bands being decorated with a fine floral pattern, which appears much finer and closer in the actual piece than in the enlarged photograph. The triangular spaces were given texture and tone by fine, closely spaced lines which were etched



Silver Bookends designed by Janet Wood, a pupil of the author

rather deeply. These were done free-hand, as it was not possible to trace this part of the pattern.

The tree design consists of an etched pattern of raised and lowered masses which are not decorated, but depend for their beauty upon the good size, placing and shape of both background and unit forms. Although not advisable for inexperienced workers, it is possible to use three different surfaces instead of two.

The horse, which is more modern in treatment, required considerable sawing as well as a longer time in the acid bath, so that the body with its pronounced curves and angles would be more prominent.

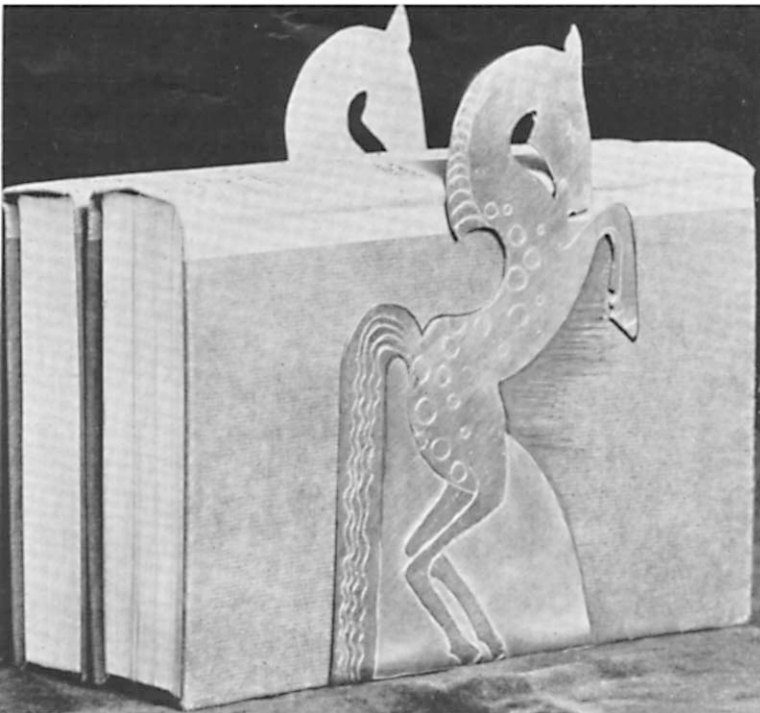

Silver Bookends designed by Ruth Miller, a pupil of the author

Of course the character of the design must be determined first, as it is of far greater importance than the method used. That is, a pattern depending for its beauty upon a series of smooth, unbroken masses against a lowered background could not be handled in the same manner as a pattern composed of numerous fine lines.

The size is optional, of course, six inches being the best length for the bracelets, with the width varying from one-half inch for the small to an inch for the large. The other pieces have a wider range within certain limits; a very large bookend appears cheap, while one

too small is not practical. The tree set is four inches at the highest point and three and a half at the widest, the part turning back being two and one-half inches deep. The horse is larger, being almost seven inches tall and three and three-quarters inches wide with a three-inch base.

The method of preparing and cleaning the silver is the same for all pieces, but the manner of applying the design varies somewhat. It is essential that the metal be thoroughly clean, but not polished. In fact the tracing is more easily seen on the duller surface. A little salt and vinegar rubbed on the metal is the simplest way of cleaning. A soft cloth may be used for wiping the silver and for handling it afterwards, as the fingers must not touch the metal after cleaning.

The design for the bracelet should be transferred from the drawing paper to a piece of thin, tough tracing paper by placing the paper over the drawing and using a hard pencil. The clean silver is placed over a gas or electric plate and heated, so that it will melt the ground when the ball wrapped in silk is passed lightly over the metal. The thin film of ground may be rolled smooth with a photographer's roller, but this is not necessary if the coating is thin enough and smooth. After cooling, the piece is put on a drawing board and the tracing, which has previously been chalked on the back, is fastened over the metal with thumbtacks close to the edge, but not touching it. The tracing is done with a sharp, hard pencil. The hand must not touch the metal even with the

paper between the two, as the ground will rub easily.

After removing the tracing, the design, which shows in a broad chalk line on the ground, is gone over with a fine, sharp metal point. This breaks through the ground. The point may be a Victrola needle in a little holder, a large darning needle thrust through a cork for a handle, or any other similar fine point. No effort need be made to scratch the metal; simply cut the ground so that the acid will act upon the silver. An even, smoothly flowing line must be made, as broken places will show in the acid bath and, of course, in the finished piece. When the needling, as this part of the work is called, is finished, paint the edges and back with a coating of the hat dye to protect the rest of the piece from the acid. It should be thoroughly dry before being placed in the liquid for etching.

The acid bath must be mixed about two hours before required, and consists of about forty per cent acid and sixty per cent water. These proportions cannot be definitely given, as the temperature affects the action of the acid. If the mixture is too strong and eats through the ground, it must be diluted with more water and, if it seems to act too slowly, it must be strengthened by adding the acid gradually and stirring with a soft feather or an old paint brush. The acid will spoil the brush.

The length of time required for the acid bath varies. Any breaks in the ground or the varnish must be patched by removing the piece from the acid, blotting it until thoroughly dry and painting again with the hat dye. In judging the depth of the pattern, allowance must be made for the coating of varnish, as the etching always appears deeper in the acid.

Remove the varnish with a little alcohol and clean the ground with gasoline or coal oil. Polish the metal with fine pumice and file the edges, slightly rounding the corners

(Continued on page 39)

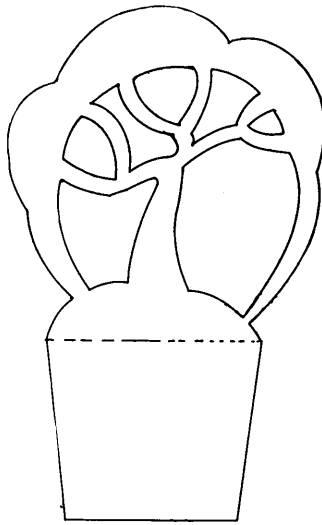

Tree design ready for varnishing after sawing.

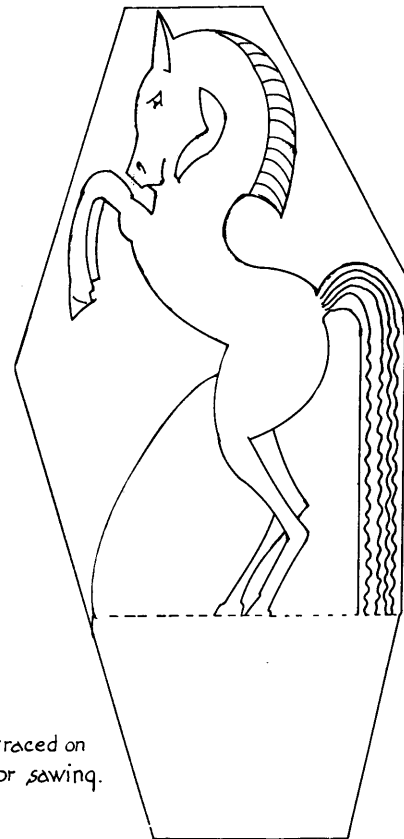

Horse design traced on silver ready for sawing.

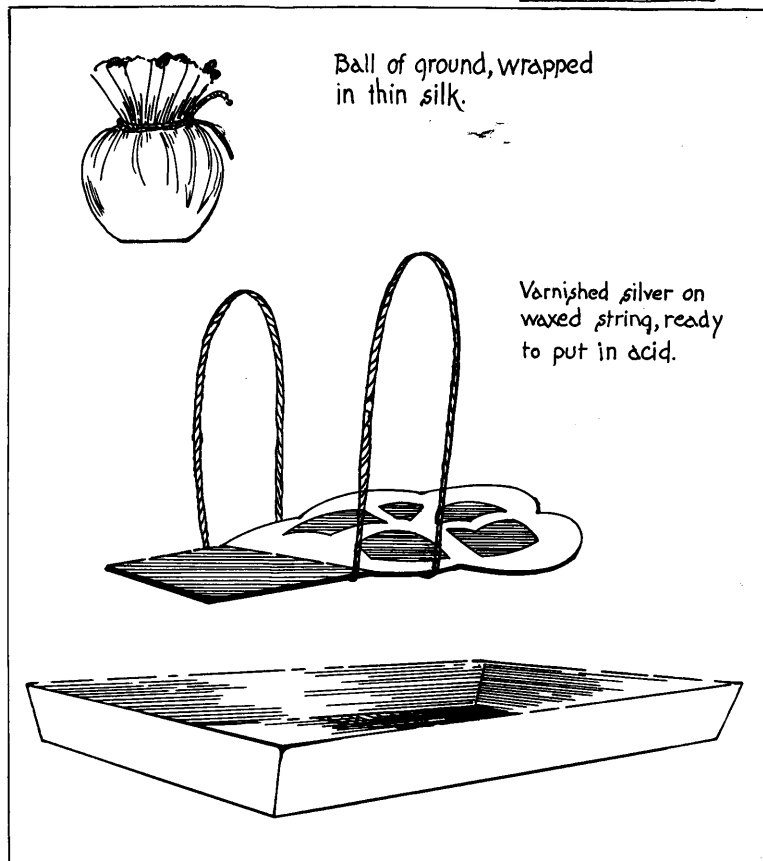

Ball of ground, wrapped in thin silk.

Varnished silver on waxed string, ready to put in acid.

A Utility Bag

BY HERMINE ROBERTS

WHAT *shall* I give her for Christmas?" This puzzling question must be settled ere long by all who have a friend who seems to have everything. Just anything will not do. She seems to demand something unique.

colors were used in the flower shapes for accents. If the background was of dark blue, black, brown, green, etc., the design parts were of lighter tones and brighter colors for contrast.

For the most part, the linings were of moiré,



A Group of Utility Bags

The utility bag answers this purpose, and can be made so attractive that it will be coveted by everyone who sees it.

The bags in the accompanying illustration were made of felt and were decorated with designs of felt, also.

When a light tone of some color, such as tan, was used for the bag, dark tones of blue, brown, green, etc., were used for the majority of the design parts (*e.g.* stems and leaves), and small spots of bright

taffeta, or silk crêpe, repeating or harmonizing with the brighter colors in the design.

The tops of the bags were made of wall board, or thin wood, and were stained or enameled.

Braided leather thongs, soutache braid, and silk cord were used for handles and for fastening tops to the body.

The following directions for making the utility bag may be found useful.

Cut a wrapping-paper pattern according to the

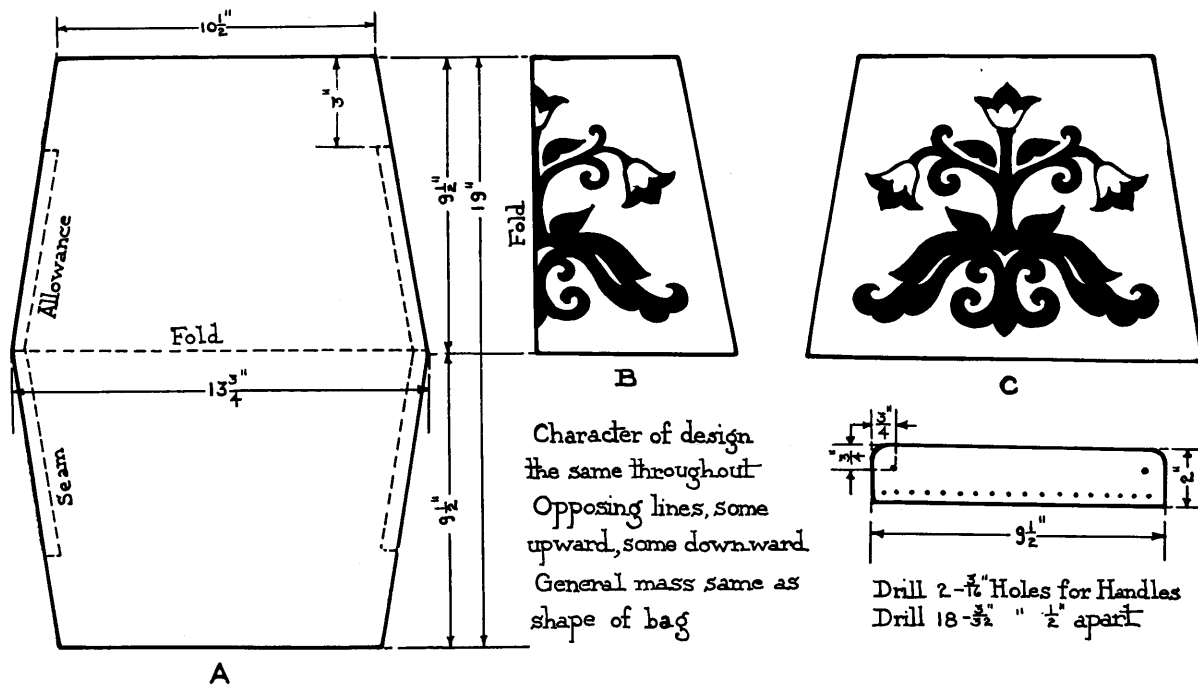

Design for Utility Bag

dimensions given in Diagram A. Cut a piece of felt and lining material like this.

A simple, bisymmetric design for one side of the bag may be made by cutting a piece of wrapping paper that has been folded vertically, as shown in Diagram B. This may be traced on to the felt with pencil to locate the position of the design parts and to insure their being fastened accurately.

Parts of the design are then cut and glued in place, or basted with thread, and may be enhanced by an outline or couching stitch of silk floss.

Fold the felt bag and lining separately and stitch, allowing one-half inch for seams, and three inches at top for bag to open (Diagram C).

With a coping saw, cut two pieces of wall board, or wood, from one-eighth to one-quarter inch in thickness, and nine inches by two inches; round corners, and sandpaper edges smooth (Diagram D). About three-eighths of an inch from the bottom and

about one-half inch apart, mark off eighteen holes and bore with a three-thirty-seconds inch bit. With a three-sixteenths-inch bit, bore a hole at either side, three-fourths of an inch from the edges, for the handles. Stain or enamel to harmonize with the bag.

With a harness, or ticket punch, punch holes in the felt to match holes in the strips of wall board, or wood.

Lace together with leather thongs, soutache braid, or silk cord.

Place the lining inside the bag and fell to top and sides, which have been left open.

Finish with handles of larger silk cord, or braided leather, or soutache braid.

Pockets for various uses may be stitched to the lining before it is put in place.

The result is a bag, rich and beautiful, which adds an air of distinction to milady's costume, and a spot of pleasing decoration to her room.

BAG FRAMES—Specials for December

CELLULOID GATE-TOP FRAMES — 10" shell only, 11" and 12" in white, black, beige, or shell, each \$1.50

METAL — a new pewter finish frame, two straight pieces 8" long, $\frac{3}{4}''$ wide, with slots at each end for handles, 65c each, or 6 for \$3.25

WOOD — as illustrated in cut: 8" \$1.25; 10" \$1.65; 12" \$2.00 each.

MOIRÉ SILK BAG LINING — excellent quality, in tan, grey, or white, 36" wide, yard \$1.25

Special stiffening for inside of envelope purses 75c yard. An excellent material, press this to your purse material with a warm iron, and you are ready for the lining.

NELLIE SARGENT JOHNSON

12489 Mendota Avenue

Detroit, Mich.



The 1931 Weaving Institute at Penland

THE craft of handweaving is fortunate in that one of its outstanding authorities is as self-sacrificing and generous of his time and knowledge as is true of Mr. Edward Worst. Once again Mr. Worst conducted the Institute at Penland, N. C., and the editor was there for the week's sessions. It seemed as if Mr. Worst was devoting all his hours to weaving, depriving himself of all relaxation in the desire to attack one more point in this complex subject. The mass of detail that he attacked was bewildering; there were excursions into draft writing; earnest coping with the intricacies of double weaving; a résumé of eight-harness weaving, round-table discussions on texture, design, color harmony, and the trends in weaving. Throughout the Institute Mr. Worst maintained a tireless pace, commencing early in the morning, often only desisting at night when the fingers of sleep closed in.

The Institute week was a success in every respect. There were visiting members from many parts of the country — the mountain section, Arkansas, New York, Massachusetts, Ohio, South Carolina, and Washington, D. C., were represented by weaving enthusiasts. In view of the limited time available for announcing the Institute, the attendance was surprisingly large, and many of the far-distant visitors had been obliged to make their decision within a few days' notice. It is to Mr. Worst's credit that people are willing to travel a thousand miles to spend a week studying under him. Numbers alone signify little — we are slowly commencing to realize that a thousand "yeas" do not mean a "right"; so the success of the Institute to the writer

is not measured by its numerical attendance. What proved gratifying to the writer was that everybody was so congenial, so determined to make the most of their opportunity, and that the Institute members did gain a good deal of knowledge from their attendance. No hidebound restrictions were laid down for the routine conduct of the Institute, and

its sessions did not run along greased rollers; but in the element of haphazardness much was gained. In the arts it is time we learned that efficiency is not necessarily conducive to beauty, and that following through processes faithfully in no measure adds to the artistry. The weavers attending, all of whom had a working knowledge of the craft, gained much more through these dartings in their field than a systematized course could have given.

To Miss Lucy Morgan, Director of the Penland Weavers and Potters, should be accorded unstinted thanks for making the Institute possible. Through years of untiring work Miss Morgan has developed the community industries in Penland; at all times endeavoring to be of assistance to the



Mr. Edward Worst

mountain people in this isolated section. Through a desire to learn the rudiments of advanced weaving, which knowledge could be conveyed to the mountain people, she studied with Mr. Worst several years ago. Having gained so much from the few weeks spent with him, she felt that she could assist the cause of mountain crafts by offering a local Institute under Mr. Worst's tutelage, and she was fortunate in being able to persuade him to undertake this task. Mr. Worst's presence in the mountains, his sincerity, which enables him to meet the

mountain people on a common ground, and the breadth of his knowledge have been of great assistance in aiding towards the improvement of craft standards.

The Institute activities were not confined to the loom alone; there were excursions into the back country with long-to-be-remembered visits to mountain homes; discussions as high mounting as the stars 'neath which they took place; friendships springing up, and gatherings at the dining table that turned into frolicsome parties. In describing the Institute for the pages of *Mountain Life and Work*, which is the magazine on mountain activities published in Berea, Ky., Mrs. Bonnie Willis Ford

says: "Altogether it was a most congenial group that met at Morgan Hall where the Institute was held. The city people were delighted with the mountain setting and the appetizing meals of fried chicken and country ham prepared for them by experts. In the cool evenings, when the day's instruction was over, they gathered around the fireplace and, in a strikingly harmonious way, shared with each other the varied experiences that life had brought to them. Although the days were, for the most part, filled with warping, beaming, weaving, and copying drafts, they found time to spend an afternoon at the potters', where they drank home-made cider from native pottery tumblers and watched demonstrations of pottery making and pewter hammering. Part of another day was spent



Mountain Boys Hammering Pewter in Molds

in visiting some of the weavers in their homes, and always the group was most enthusiastic about anything which pertained to the weavers or their work.

"The days were over all too soon, and it was with genuine regret that each member prepared to leave. Into every bag went samples of weaving, drafts, picture post cards, and exchange addresses — mementos of a very busy and a very happy week."

To everyone the Institute was a boon; and fortunate was its location. Just as we from the city have much to offer the mountain people, so can they give to us; perhaps not in the material, but something far more worthwhile, since in their open-handedness and sincerity repose gifts of the spirit that warm and elevate.



Mountain Women at the Penland Weavers Cabin

FURTHER NOTES ON THE SPECK DRAFTS

(Continued from page 11)

3	4 times	6	2 times
4	4 "	5	2 "
5	2 "	6	4 "
6	2 "	3	8 "
5	2 "	4	4 "
4	4 "	3	2 "
3	4 "	4	4 "
6	4 "	3	2 "
5	2 "	4	2 "
6	2 "	3	2 "
5	2 "		

Reverse.

There are numerous possibilities in each of the different drafts, and at least two different treatments of each draft have been prepared. For those weavers who possess or have available copies of Mrs. M. M. Atwaters' arrangements of the John Landes Book of Drafts, it will be most enlightening to compare the drafts of these patterns with some of the drafts in the John Landes Book. None of the drafts yet analyzed are quite like those in the John Landes Book, but many of them are very similar and yet developed so differently that they are well worth the comparison. The arrangements in each book suggest possibilities of new and interesting developments of the drafts in the other book.

It is to be hoped that at some time the whole set of Speck Drafts may be made available as have the John Landes Set, as the publishing of them was a most valuable addition to the store of designs and patterns for the weavers to today.



THE PROS AND CONS OF FLY-SHUTTLE WEAVING

(Continued from page 26)

be perfect, and capable of adjustment to the work in hand. The amount of weft laid in the shed depends on the length of time the shed is held open. A shed dropped on a shuttle still in motion will leave a small amount of weft to be distributed and will, therefore, cause a severe pull on the selvage threads, and prevent the weft threads from packing closely together. In open mesh work, such as scarfs, this is an advantage. In cloth to be closely woven and not narrowed in the weaving, it is fatal.

The motions must be perfectly rhythmical, following each other in the same order, and in the same tempo, or the appearance of the material will change. It is not often that weavers can interchange on a piece of work. A difference is noticeable at once, although each operator's work is excellent.

The appearance of material depends, however, on warp tension quite as much as on weft tension. A

warp tension secured by rachets is not always restored exactly after the web is taken up and the warp let out. For evenness of tension, weights, not only on the warp beam, but also on the cloth beam, are desirable. A round, revolving breast beam, covered with sandpaper, grips the woven cloth and keeps an even tension. This breast beam is geared to a wheel having the number of teeth corresponding to the diameter of the yarn in use as weft. The beater is equipped with a bar controlling pawls which fit into the pick wheel. Thus the cloth rolls forward with each stroke of the beater, so that no time or rhythm is lost in stopping to adjust the warp. This device by no means removes from the operator the necessity for perfection of coordination. There are merely more ways to make flaws in the cloth.

Given an intelligent weaver, with a sense of rhythm, a capacity for concentration, an alertness of eye and ear and a control of muscular effort, quite as beautiful material may be woven with a fly shuttle as with a hand-thrown shuttle. It may be made with less physical fatigue, as motions are simplified and the force required is decreased. The rhythm so necessary also reduces effort and fatigue. And the output is multiplied by any figure from two to ten, depending on the ability and endurance of the weaver.

Instruction in Weaving

BY THE COURSE OR SINGLE LESSONS

The Garden Studio

KATE VAN CLEVE

14A MARSHAL STREET, BROOKLINE, MASS.

9 to 12 a.m.

MONDAY WEDNESDAY FRIDAY

**HANDICRAFT
NEW INSTRUCTION MANUAL***Printed July 1931 — Price \$1.00*

300 Projects

400 Illustrations

SIMPLIFIED INSTRUCTION*in Leather, Celluloid, Metal, Woodcarving,**Batik, Primitive Crafts***HANDICRAFT SPECIALTIES***Tools — Materials — Instruction**Price List on Request*

LESTER GRISWOLD

Colorado Springs, Colorado

BLOCK PRINTING YOUR OWN CHRISTMAS CARD

(Continued from page 29)

to clean rollers and blocks when necessary, and a bit of gasoline on a cloth for your own fingers. When through printing, clean roller and block with gasoline if oil paints or printers' ink have been used. Water, of course, for the other mixtures.

If the prints are done in black, a bit of color may be added with watercolors when the ink is dry. This, of course, is against all rules of proper block printing, but just now we are making Christmas cards. Very little paint should be used, tiny bits of light, bright color are much better than large washes. Dark reds, purples, blues tend to dull the whole effect and should be avoided.

If you use boughten envelopes it is wise to select them at first and plan your card size to fit. While it is a bit tedious, having made one good pattern you can make your own envelopes with a little patience. Also the card can be printed on fairly heavy paper, allowing a good space at either side. These can be folded together, lapping a little and fastened with a seal, so that no envelope is needed. You can even print your own seals on bright paper. Several designs can be engraved on one block, printed and clipped apart. This insures speed and variety in the making of seals.

You will find that the pleasure of accomplishment will more than repay you for the labor. There is, however, one drawback which it is only fair to point out. Once you have produced your very own card and listened with that pleasant little glow to the flattering comments from your friends, you will never again approach a counter to buy your cards without feeling a little sheepish, a bit trifling. Which does make it something of a chore!

BOOKENDS AND A BRACELET

(Continued from page 33)

but keeping the edge square with no bevel. The shaping must be done gradually, beginning at the center and working evenly on both sides so that the curve, which should be oval, not round, will be uniform. A final polishing with silver polish completes the bracelet.

The bookends with the tree design require no ground, as the masses are plain. When the silver has been cleaned, the design is traced on the metal with heavy carbon paper and a hard pencil. All the parts which are to be raised, in this case the tree and the base of the bookend, as well as the back and edges are painted with the varnish. If possible, both pieces should be put in the acid at the same time, as the depth of the etching ought to be uniform. As the undecorated masses are larger in this design, the etching should be quite deep to give tone to the

finished piece. Of course the deeper the background, the darker it appears and the greater the contrast between that and the pattern.

Cleaning and finishing are much the same as in the other piece, except that the edges of the base may be beveled slightly. The finish is improved by a coat of lacquer, which makes a permanent polish.

The modern horse is made by a combination of the two methods. The silver must be clean, and a ground put on just as in the bracelet. The tracing is applied in the same manner, also using the chalked outline. All the lines upon the raised surfaces are needled with the sharp tool, and the ground removed from the lowered surfaces with a small piece of cotton wrapped around the handle of a small paint brush. If the ground does not come off easily, the cotton may be dipped in alcohol, but of course it must not touch any raised portions with the lines, or all the work will have to be done over. The back and edges are painted, and the silver is ready for the acid. Small breaks in the ground can be patched, just as in the others, by painting around the lines.

All of the pieces must be watched while in the acid and, if bubbles come from beneath the metal, removed and the back patched. The sketch shows the method of putting the silver in the acid bath and also of removing it. The string must be well waxed to prevent the acid eating it. It should be fine and well twisted rather than coarse and soft.

The horse bookends are finished in the same way as the tree design. As the bending of the base is a tedious process and purely mechanical, it is better to have it done by machine. Any auto repair shop is equipped to do this quickly and easily. If lacquer is used, it should be put on after the piece is bent.

The Cathcart Looms School of Weaving

Studio

132 West 87th Street, New York City

Offers a practical training course
in all branches of hand-weaving.
Small looms for the home weaver.
Fly-shuttle and pick-wheel meth-
ods for quantity production.

Until October 1st, address

FLORENCE B. CATHCART
THETFORD, VERMONT



For Christmas Gifts

HAND HAMMERED PEWTER HAND WOVEN TEXTURES

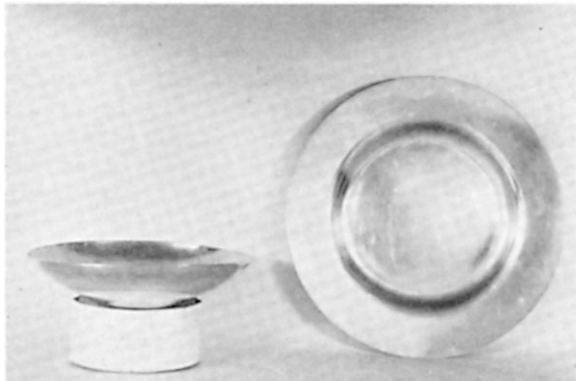

Pewter is an appropriate holiday gift. Its practicability, charming shapes, and exquisite color always appeal.

The Penland Weavers and Potters offer pewter plates, hand hammered by mountain youth. Prices are as follows:

4" diameter	\$.60
6" diameter	\$1.00
8" diameter	\$2.00
10" diameter	\$3.00
12" diameter	\$4.00

Send orders to

THE PENLAND WEAVERS AND POTTERS
Penland, N. C.



Wool scarves and shawls from the Arrowcraft Shop. Woven in soft wools and delightful colors. This Shop also offers linen towels, luncheon sets in colonial and laid-in patterns, handmade furniture.

THE ARROWCRAFT SHOP
Pi Beta Phi Fraternity School, Gatlinburg, Tenn.

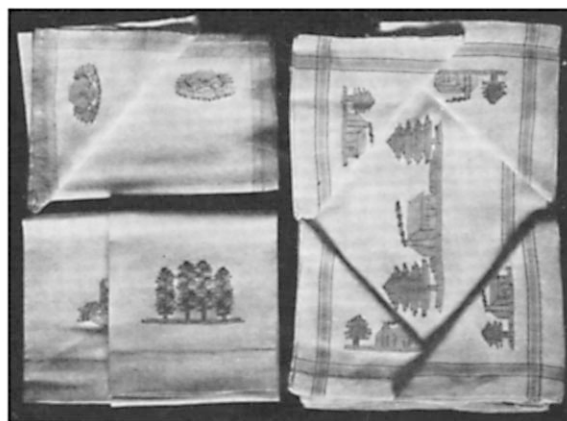

The Spinning Wheel has always specialized in unusual laid-in weaves of excellence in design and color. Amongst its offerings are also automobile robes, dress fabrics, and hooked rugs.

THE SPINNING WHEEL
Beaver Lake, Asheville, N. C.

The above craftsmen groups are members of the Southern Mountain Handicraft Guild. This Guild consists of a number of craftsmen and schools banded together in a cooperative group and producing a wide variety of craft articles, including furniture, toys, baskets, pottery, embroidery, and weaving. The Guild members sell wholesale and retail—also in consignment.

For further information, write

MISS HELEN DINGMAN, Secretary, SOUTHERN MOUNTAIN HANDICRAFT GUILD, BEREA, KY.



Structo Artcraft Loom No. 420

This is the newest loom in the Structo family and it is proving popular

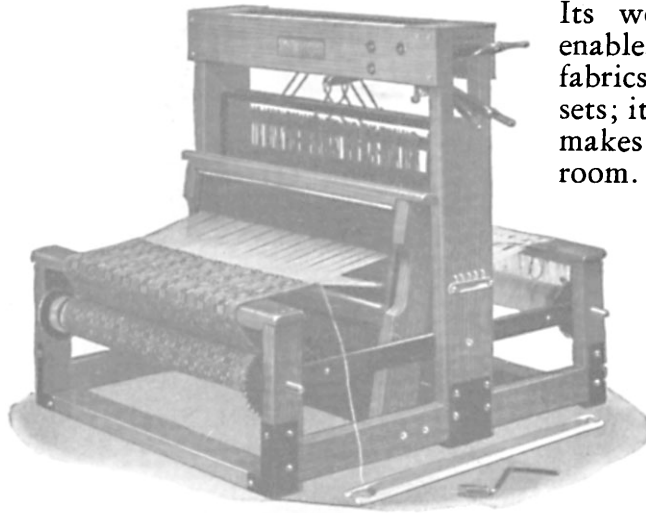

Its workable width, fourteen inches, enables the weaver to produce practical fabrics like bag material and luncheon sets; its inexpensiveness and compactness makes it a handy addition to the weave room.

Write for latest catalogue, describing this loom and other Structo products

Our new weaving manuals are now ready. These manuals contain adequate instructions on the warping and manipulating of the looms; and there is a special set of drafts with treadling directions for each loom model. The instructions are written so simply that a novice can follow them. The manuals are priced at \$1.00 each — in ordering specify the loom for which it is wanted.

THE STRUCTO MANUFACTURING COMPANY + FREEPORT, ILLINOIS

Hand Weaving

Mary M. Atwater, author of the Shuttle-Craft Book of American Hand Weaving, offers a course of instruction by correspondence designed to meet the needs of those who desire a thorough knowledge of the craft of weaving. Those who have never woven may become expert weavers through this course, and many weavers of long experience subscribe for the material for the sake of the many unusual weaves that are explained and also for the explanation of draft writing. The course includes a textbook and lesson sheets, criticism of work sent in and unlimited correspondence privileges. All the instruction is given personally by Mrs. Atwater. Subscription to the course carries with it membership in the Shuttle-Craft Guild with its various activities.

For further information address the

**SHUTTLE-CRAFT GUILD
or MARY M. ATWATER**

Box 31-H

Basin, Montana

STUDIO CLASSES

in ARTS and CRAFTS
TEACHING

Courses in leather, basketry, gesso, primitive crafts, polychrome, batik, tie-dye, jewelry, light metal and jig saw.

An Opportunity

for School Teachers, Camp Fire and Scout Leaders, "Y" Secretaries, Camp Counselors, Woodcrafters, Occupational Therapists and Hobbycrafters.

CLASSES OPEN OCTOBER 1, 1931

Telephone: Spring 7-8382

ELENORE M. STORR

**139 MACDOUGAL STREET
NEW YORK CITY**

THE KIRCHER LOOM

is a frame with a specially designed reed attachment for creating the shed, and it takes long lengths of warp

THE KIRCHER LOOM can be worked when it is rested against a table or a desk; to create the shed it is only necessary to raise and lower the reed bar, which also acts as a serviceable beater.

The Kircher loom is suitable for the classroom, occupational therapy department, home, and child's playroom. The weaver can use it for any type of

shuttle and an instruction manual which gives all necessary information on putting the loom together, warping it, and the mechanics of weaving. This loom takes eight warp threads to the inch.

Prices for the KIRCHER LOOMS are as follows (shipping charges are extra):

No. A, 14 inches in width \$3.75



The Kircher loom

two-shed weaving like tapestry, laid-in weaves, Swedish weaves, and plain stripe work.

The loom comes in three sizes, and is supplied in knock-down form. With each loom we supply a

No. B, 20 inches in width \$5.25

No. C, 28 inches in width 7.00

On single orders for one dozen looms or more, there is a discount of 15 per cent from list prices.

Special rates to dealers and weaving teachers — write for details.

EMILE BERNAT & SONS CO.

89 Bickford Street, Jamaica Plain, Mass.