

LOOMCRAFT

Single copy 1/3d. post free.

5/- per year inc.post.

BY WEAVERS—FOR WEAVERS—ABOUT WEAVERS

Volume Three.

April 1962.

Number 1.

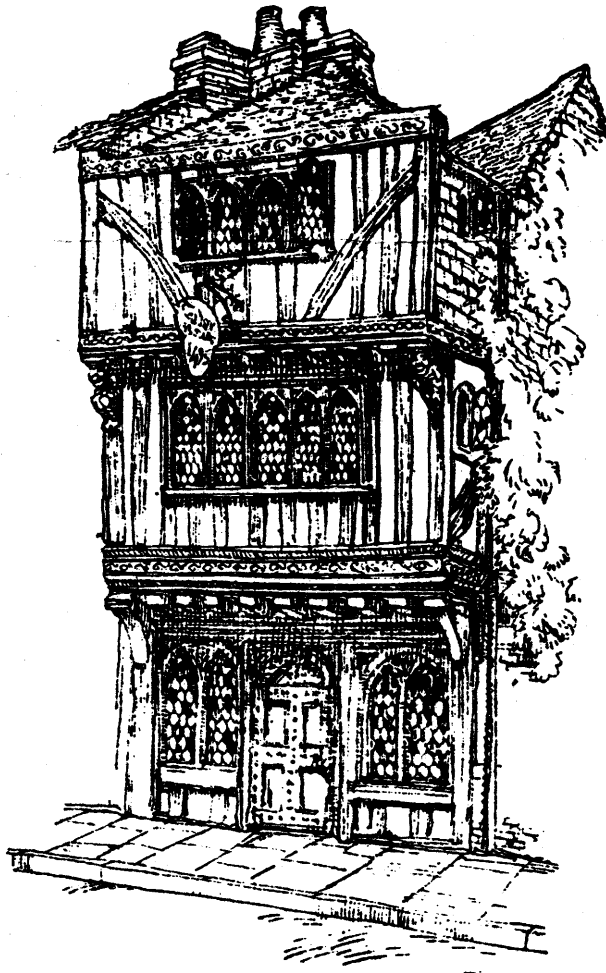

"HOME OF LOOMCRAFT"

Editorial.
"Palace" Boat Shuttle.
Tuition.
Gay Check Mats.
Bonus Scheme.
Readers' Write.
An Old Favourite
Repeated.
Cushion Cover -
Woven Sample.
Plastic Beach Bag.
Beach Jacket and
Shorts.
Handicraft Conference
& Trade Show.
Special Offer Yarns.
Sales and Wants.

"LOOMCRAFT" is issued
four times a year -
Jan. April. July and
October.

8, Palace Street,
CANTERBURY.
Kent.

April 1962.

Dear Readers,

How quickly the months slip by! Many of our friends say, "I wish LOOMCRAFT came out more often". We would very much like to comply with this wish, but believe me, we have only just found a lull in the flood of orders which have continued to pour in from the January number!

We hope that once more you will find something to please all of you amongst the articles we offer in this issue. We do try to give something for everyone.

With the Handicraft Teachers' Conference and Three Day Trade Exhibition being held during Easter Week, we have decided to close 8, Palace Street for the whole of this week, namely April 23rd. to April 28th inclusive so please note that no despatches will be made at all during this period, and when we re-open on April 30th we may have to keep you waiting a day or two in order to catch up with the accumulation of orders and correspondence which will be waiting for us. So, please bear with us and if possible send your requests in as early as possible or, if there is no great hurry, wait until May is with us.

May we take this opportunity to thank you for all your patience which we know you will extend during this period.

Apart from the above Conference, Canterbury is going to be a busy City during the Summer months as it is our Festival Year and many unusual events are planned to take place during this time. Why not come and join in the Festivities with us?

Sincerely yours,



MARGARET A. NORRIS (MRS.,)

JUST WHAT YOU 'VE ALWAYS WANTED.

How about using up more of the warp when the shed is too narrow for your standard size shuttle?

How about inserting a single pick of distinctive coloured yarn to give a cutting line when each design is completed on a longish warp?

Of course, you always do - but how? Do you fiddle it through the shed with your hands and fingers - with a piece of stick - or waste time looking for a stick shuttle and fail to find one that is not already filled? What is needed for just such a purpose, and indeed for any occasion demanding a quick change of yarn is the new "PALACE" Boat Shuttle.

Nothing of an unknown quantity - not something a "yard foot and a thick wide", but a perfectly balanced, light and handy shuttle - 6" long, just under $\frac{3}{4}$ " high, yet it takes a 3" pirn which in turn carries, if needed, a surprising quantity of yarn.

The new "PALACE" Boat Shuttle is made of polished beech, fitted with a tempered spring spindle hinged at one end, engaging its open end in a positive instant. Locking and release plate. No time lost hunting around for the spindle that has dropped out and got mislaid. You will wonder as we do - how you ever got along without it!

As for comparison with the usual stick shuttle for use with the smaller table loom, it is "just the job". A joy to handle - quicker and so much more efficient - apart from giving that added professional look to your equipment.

You can't afford to be without one or more - and you can afford to treat yourself to at least one - it costs only 5/6d. postage 6d. extra.

TUITION.

Canterbury is delightful in the early Summer and Autumn and one can move around in comparative comfort. Accommodation is easier and the coastal towns are so close. If you are taking your holiday at these times, why not have a week or so here and devote the mornings to a course of weaving? Then, use the afternoons and evenings for visits to the surrounding district.

We are always happy to help you if we can and a course of twelve hours or so is a very sound investment.

GAY CHECK MATS.

After the wonderful reception which the Linen Luncheon Mats received, we are tempted to give a pattern for mats suitable for the odd meals we shall hope to arrange in the garden this summer.

These are in a check design using coarse linen and an unbleached gimp. A fashionable colour this year is cerise and we can offer our readers some linen in this colour at an almost "give-away" price! To weave six place mats and one square centre mat you will need $\frac{3}{4}$ lb. of linen in cerise and $\frac{1}{2}$ lb of unbleached gimp. This will cost 11/6d., in all and look very smart on your garden table.

We used a 14 dent reed sleyed single through the dents and the healds were threaded singly in plain weave threading - 1, 2, 3, 4 repeat for a four shaft loom, or 1, 2 repeat for a two shaft loom.

The beauty lies in the striping of the warp and weft and should be as follows:-

For the fringe we laid 8 ends of a cotton (this is later removed) then:-

1 end Gimp)	
1 end Linen)	
2 ends Gimp)	19 times.
1 end Linen)	(228 ends)
1 end Gimp)	
6 ends Linen)	
1 end Gimp)	
1 end Linen)	Once
2 ends Gimp)	to balance
1 end Linen)	(6 ends)
1 end Gimp)	

finishing with 8 ends of cotton which are removed when the fringing is done.

The warp should be 3 yards long and 250 ends include the cottons. The actual weaving follows the same order as the warp and so gives the checked appearance. When all the mats are completed and removed from the loom, a fringe all round should be made by either machining along the outside gimp thread or hemstitching and then fraying out the eight cotton threads which will leave the warp and weft ends free. Steam press the finished mats and they will then look most professional and ready for use.

If the Cerise Linen we are offering at 10/- per pound does not appeal to you, try the standard 8/2's Mercerised Linens that we have on our Special Offer List, but here you must allow a little more as it is thicker than the cerise. Fortunately, it is on 2oz tubes, so I think 7 tubes will be enough. The cost of course is considerably more, but maybe you will want to weave a set which is going to give service for a very long time and as you know, linen improves with use and laundering.

A BONUS SCHEME FOR OUR READERS.

We have been thinking about some way to start a scheme which would give a little bonus to our many friends from whom we are always receiving small, but very welcome orders.

As we already have quite a lot of book-keeping to keep up with in order to record your purchases, we did not think it would be advisable to start another recording problem! So, we shall send to you with each invoice sent out after this number of "LOOMCRAFT" is issued, a slip which will act as a check, recording $2\frac{1}{2}\%$ of the purchase you have made. These we shall ask you to keep together until you have 2/6d. worth or more, and then send them with your next order, deducting the total amount of the checks returned from your remittance. We shall then retain these and show the deduction on that invoice. Then, you start again to save further checks until 2/6d. worth or more is collected. In this way it is up to you to watch the pennies for yourselves!

This offer applies to everything we offer - looms, equipment, books, yarns and if you take it, tuition. The only thing we shall not include is postage and packing as this shows no profit - very often the reverse, on our turnover.

ANOTHER USEFUL SUGGESTION!

Mrs.V.Williams, of Seaham, Co.Durham writes:- "Perhaps your readers would be interested to learn how I use up my warp ends. The smallest pieces of wool I turn into Chenille, either by sewing together on the machine or making a long crocheted chain holding a tuft in each loop. These lengths are woven into rugs - cotton is used to make tufted bathroom mats, very satisfactorily - wool or cotton short lengths can also be knitted in tufts for toy animals or tea cosies. All these suggestions make very pleasant fireside hobbies. I would like to add that I enjoy reading other readers letters very much."

Miss W.Harriott, of Gosforth, Newcastle-on-Tyne wrote us a very charming letter after having made a set of Luncheon Mats from instructions given in our last issue of "LOOMCRAFT":-

"I thought you might like to see the sample mat I made from your pattern for Luncheon Mats. I found your draft very simple to follow, but adjusted it to suit a smaller mat. As regards "LOOMCRAFT", I only wish it were a monthly issue but I know this is expecting too much! Incidentally, I think "LOOMCRAFT" is far and away superior to the American "Warp & Weft"."

Mrs.E.Voller, of Velson, New Zealand writes:- "I love "LOOMCRAFT". I wish I lived nearer. I am getting old but although I am shakey I can still weave and spin well."

"PEM'S FANCY" - AN OLD FAVOURITE IS REPEATED.

In a very early number of "LOOMCRAFT" we gave a modification of an overshot pattern and called it "PEM'S FANCY". It has proved such a favourite, both with visitors to our Showroom and amongst our many weaving friends, that we feel a revival of this pattern for our newer readers will be an advantage.

It is a threading which looks best in fine yarns and the nicest version I have seen was woven in 16/2's mercerised cotton for the warp sett at 28 e.p.i. and a 12/2's mercerised coloured cotton for the pattern thread, using 16/2's for the binder and I thought you may like to have a table or sideboard runner in this setting.

To give a width on the loom of approximately 16", you will require 451 ends as follows:-

Selvedge	12 ends.
Border	73 ends.
12 Patterns (22 ends).....		264 ends.
1 Part Pattern (17).....		17 ends.
Border	73 ends.
Selvedge	12 ends.

451 ends.

and it should be as long as you require the finished runner (allowing for the plain weave hems), plus about 18" for the tie-on wastage on the loom. If you decide to make more than one, it is only one wastage however many you weave - a great saving in the long run. I estimate a good 4oz will make a 3 yard warp and the binder rows for a runner a little over two yards finished.

The pattern weft for this length will need at least 4 oz according to the amount of beat you can get. Make a generous plain weave hem at either end as this gives beauty to the finished article - 6½" to 7" would give you a 3" hem. I would suggest once through the small pattern to begin and then the border lifts. Now measure the depth of this weaving so that you can calculate how much you should allow in the centre for the pattern repeats before you start the concluding border and hem. I have indicated the actual start and finish of the border.

Keep a nice even selvedge when weaving and if you wish it would be a good policy to thread the first and last two dents of your 14 dent reed with four ends each so giving a firm edge, but the rest of the warp should be 2 to a dent, so making 28 e.p.i.

Following our usual practice, you will find the threading draft and weaving lifts on the insert of this magazine.

THREADING DRAFT FOR "PEM'S FANCY".

```

      4 4 4   4   4 4 4 4 4           4 4 4 4 4   4   4 4 4           4           4
    3   3 3 3   3 3 3           3 3   3 3           3 3 3   3 3 3   3           3           3
    2 2           2   2           2 2 2 2 2 2 2 2 2 2           2   2           2 2           2           2
    1 1           1 1           1 1 1 1 1           1           1 1 1 1 1           1 1           1 1           1           1
  
```

..... Border 73 ends Selv. Shafts.
 3 times.

```

                x
              4 4 4 4 4 4 4 4 4 4 4 4 4
            3   3   3 3 3 3   3 3 3
          2   2 2   2 2
        1   1   1   1 1
  
```

Selv. Pattern 22 ends
 3 times.

Selvedge 12 ends.
 Border 73 ends.
 12 Patterns (22 ends)..... 264 ends.
 1 Part Pattern (17) 17 ends.
 Border 73 ends.
 Selvedge 12 ends.

451 ends.

Note x marks 17th thread for Part Pattern
 now return to border threading.

Standard tie-up is used for pedal looms.

Always follow a pattern row with a binder row.

X	∅								
<u>Healds.</u>	<u>Pedals.</u>	<u>Times.</u>	<u>Healds.</u>	<u>Pedals.</u>	<u>Times.</u>	<u>Healds.</u>	<u>Pedals.</u>	<u>Times.</u>	<u>Healds.</u>
1 & 4	6	1	1 & 4	6	4	1 & 4	6	1	
1 & 2	1	1	1 & 2	1	4	1 & 2	1	1	
2 & 3	2	1	2 & 3	2	4	2 & 3	2	1	
1 & 2	1	1	1 & 2	1	1	1 & 2	1	1	
1 & 4	6	1	2 & 3	2	4	1 & 4	6	1	
3 & 4	5	4	1 & 2	1	4				
2 & 3	2	1	1 & 4	6	4				
1 & 2	1	1	3 & 4	5	4				
1 & 4	6	1	2 & 3	2	1				
1 & 2	1	1	1 & 2	1	1				
2 & 3	2	1	1 & 4	6	1				
3 & 4	5	4	1 & 2	1	1				
		∅	2 & 3	2	1				
			3 & 4	5	4				

X

Work between X - X for first border, then repeat
 from beginning ∅ - ∅ for centre.

Work between X - X for final border, and then the
 5 lifts marked Balance.



"ROSEPATH" IN ANOTHER DRESS!



The summer days call for comforts which can easily be moved out into the garden and countryside. Creature comforts spell cushions and rugs to me, but I also like to have gay colours around me. So, this sample is suggested for cushions which will look well and wear well.

Using 6/2's plain warp cotton and sett at 18 e.p.i. a firm warp is put on the loom using a 9 dent reed double sleyed, or a 12 dent reed double sleyed 2 & 1 alternately. The usual "Rosepath" threading is carried out, threading the healds singly.

ROSEPATH THREADING.

4		4	4	4	4
3	3		3 3	3	3
2	2		2 2	2	2
1	1		1 1	1	1

Selv. once. Pattern 8 ends. Selv. twice. Shafts.
 (7 ends) repeated. (8 ends)

For approximately 20" off the loom you will need 375 ends which would give 45 patterns plus the two selvages. The length of the warp would depend on the number of cushions you require. It is a good idea to weave 1" of plain weave at the beginning and end of each cushion in the same yarn as the warp for a small hem when making up the cushions.

After the plain weave, commence the pattern weaving using 6/2's mercerised cotton for the coloured part but something much finer for the binder. We used a natural 40/3's cotton which can be purchased at 2/- per 2.oz tube. (See the Special Offer List).

WEAVING LIFTS are as follows:-

<u>Shafts.</u>	<u>Pedals.</u>	<u>Times.</u>	
1 - 4	6	1) Repeat throughout. A binder row follows each pattern row. Binder rows are 1 - 3, 2 - 4 alternately.
1 - 2	1	1	
2 - 3	2	1	
1 - 2	1	1	
1 - 4	6	1	
3 - 4	5	4	
2 - 3	2	1	
1 - 2	1	1	
1 - 4	6	1	
1 - 2	1	1	
2 - 3	2	1	
3 - 4	5	4	

Continued on Page 8.

FOR THE WET SWIM SUIT.

What to do with the swim suit after the bathe is always a problem, so why not weave a strip of cotton and plastic which can be fashioned into a large envelope in next to no time!

Here is how I would suggest it is done. A $\frac{1}{2}$ lb ball of heald cotton sett at 7 or 8 ends per inch would make the warp for two envelopes of 15" x 10" finished, and the weft would need 1 lb of Plastic Strip for the two. Use contrasting colours and then a little of each one can be used in the other. A little pattern could be introduced by threading the healds in modified Goose Eye which is as follows:-

4 3 2 1		4 3 3 2 2 1		4 3 2 1		4 3 2 1
Selv.twice	Link	Patt.repeat.	Selv.twice.	Shafts.		
8 ends.	to end once.	8 ends.	8 ends.			

If you are using a setting of 7 e.p.i. it will need 113 ends to allow for the two selvages, the odd end for the link, 16 repeats of the pattern, and will be approximately 16" on the loom. The weaving lifts will be the same as those used for twill weaving. 1 & 2, 2 & 3, 3 & 4, 4 & 1 repeat. Weave about $\frac{1}{2}$ " of plain weave with thick cotton or wool and this will act as a small "turn in" when making up. Now weave approximately 30" in plastic strip using the colour to suit your tastes, finish off with another strip of plain weave as at the beginning. Now do the second 30" strip, turn the ends and machine the hems. Fold into three to make the envelope and join up the sides to hold. A large press stud at each corner of the flap will secure it.

The total cost of two envelopes for swim suits will be 14/3d. which is 4/3d. for the warp and 10/- for two rolls of $\frac{1}{2}$ " plastic tape. The tape comes in Black, White, Blue, Beige, Green, Yellow and Red.

"ROSEPATH" - continued from Page 7.

It would look very smart to have a contrast colour for the 5 single pattern rows of each repeat, and the main colour for the 4 rows of shafts 3 & 4. In this way variety can be introduced to a set of cushions all made on the same warp.

Allow a little over 4oz of 6/2's plain cotton for the warp of each 20" x 20" cushion cover and 4oz of 6/2's Mercerised Coloured Cotton for the weft of each one. A 2oz tube of 40/3's or similar count for the binder will be sufficient for at least 4 cushion covers. A total outlay per cushion cover would be approximately 6/6d.,

JAUNTY BEACH JACKET AND SHORTS.

We hope that the summer ahead will have lots of ~~warm~~ sunny days so that we shall all need some new attractive Beach Wear. With this in mind, we offer you the suggestion and "know-how" to make a short Beach Jacket and perhaps shorts to match.

Most pattern books offer this type of thing and "Simplicity" in particular offer a pattern for a Jacket and Shorts which takes three yards of 36" material or four and half yards of 27" width. We have tried this out for ourselves and found the result most pleasing.

A coloured 6/2's cotton for the warp, sett at 20 or 21 e.p.i. with a plain weave weft of white gimp is a very good combination. You will need 1½ lbs. of a coloured 6/2's mercerised cotton which will cost 23/9d. and 1 lb. of fine white gimp at 8/- per pound to weave enough for the complete outfit of Jacket and Shorts. If you require the Jacket only, then your requirements should be cut by approximately one third.

The Jacket is without sleeves of course and reaches down to the thighs. Some patterns give large patch pockets but if the pattern you choose is without them, then it is quite easy to add these. It is usual to join them to the bottom of the jacket and the width could almost be from the centre front to the side seams. A belt is necessary and we used up some of the pieces left over to make one to match. Apart from this no fastenings are used.

We do not advise a patterned weave as this may entail more material than suggested. A good strong colour for the warp and the white gimp weft will appeal to many of our readers, but if you prefer a plain unbleached, i.e. off-white, warp, then you must have a coloured fine gimp. In this material we can offer Lilac, Lime, Lemon and Reseda. Some Nut Brown is available but not very much. All these colours are on offer whilst stocks last but we cannot guarantee to repeat.

If your taste calls for something thicker, then we have the Rayon Gimp in Black and Green, but be prepared for it to need 2 lbs. for the weft. All these yarns are given on our various price-lists with many others.

ARE YOU WEAVING A LENGTH OF TWEED?

Do remember to throw 8 or 10 picks of plain weave at the start of your project and again at the end. In this way you will ensure that during the finishing process it will not unravel at all. Any old waste yarn will do.

Incidentally, tweed can be sent to us for finishing, the charges being 1/9d. per yard or part of a yard, plus the return postage. Please allow 14 days for this service.

MORE OF THE HANDICRAFT TEACHERS' CONFERENCE.

The Trade Exhibition which is being held in conjunction with this Conference is open to the public from 10 a.m. until 6 p.m. daily from Weds. April 25th until Friday April 27th. We hope that as many of our friends as possible will come and see, not only our display, but all the other many interesting crafts. The various business houses are making a very fine effort to give as many live demonstrations as they can, so a day of great interest can be promised to all members of the family.

The Frank Hooker School, where this is being held, is on the London Road Estate which is just off the A.2. road, and the City Service Bus No.25 will take you to the School Gates. For those travelling by road there will be adequate car parking space. You will find us on the top floor and a very pleasant room it is - we have a good area and plan to put on plenty to interest everyone.

The new Warping Mill will be demonstrated daily and judging from the preliminary demonstration we gave to the Kent Branch of the Institute on February 17th, it will be keenly examined by the mechanics as well as the actual performance for the weavers!

We have invited Mr. Hewitt of Broadstairs, our blind weaver, to come over each day to weave on a "CHILTERN" Foot Loom. You may remember that he was at the Broadstairs Hobbies Exhibition during Easter week last year and he is looking forward to the Show very much indeed. Also, we shall have another "CHILTERN" loom working at intervals during the day.

A bank of dressed "PALACE" Table Looms will be at the disposal of the public if they are interested in trying them out for themselves. We have found from previous Exhibitions that this is the best way to get to know our visitors and for them to get to know us. The Spinning Wheel and some fleece, Romney Marsh, will also be in use plus the inexpensive spindles we can offer.

As far as possible we shall have yarns, shuttles, warping frames, spool racks, threading hooks etc., on show and as usual we shall be happy to offer advice on equipment problems and quote for "tailor-made" items if requested. Although we are primarily a weaving business we shall also exhibit materials we stock and supply for Embroidered Rugs, together with some examples of designs for Church Kneelers in the same medium. We shall have examples of Linens and Threads also used for embroidery. Books will be displayed so maybe you will discover something hitherto unknown to you.

You will find made-up garments of handwoven fabrics and many examples of articles given in "LOOMCRAFT" from time to time.

Do try and come - we should be so pleased to see you, and please make yourselves known to one or the other of us!

SPECIAL OFFER YARNS.

6/3's UNBLEACHED COTTON. This is a little thicker than 6/2's, in fact it is the same size as Lyscordet. An excellent yarn for medium to heavy weaving and suitable for warp and weft. The ideal setting for this yarn to produce plain weave is 12 e.p.i. but for simple pattern work where a certain amount of over-shot takes place, it could be used with a fourteen dent reed, single sleyed.

6/3's MERCERISED COTTON. The same thickness as the above giving 1,680 yards per pound. Makes a very good pattern yarn for the borders of aprons etc., A finer thread should be used for the binder thread so as to allow it to beat up closely and give a solid looking pattern band.

6's RAYON. This is a singles yarn and could very well substitute for a 12/2's in pattern weaving. It is a "shiny" thread and gives lift to any weaving into which it is introduced. For very fine "pick-up" or "laid-in" weaving it looks fine. For a binder with a fairly dull colouring of pattern thread, it lends a subtle background. The packaging is $\frac{1}{2}$ lb tubes, so at 8/- per pound it is most economical. The yardage is approximately 5,000 yards to the pound.

6/2's RAYON. This is double the thickness of the 6's Rayon, yielding 2,500 yds to the pound. This yarn can be used for warp and weft and is excellent for pattern bands but I do suggest that you use some cotton, either in the warp or weft, as Rayon on its own does not retain its crispness and after a time begins to look bright in colour but rather limp in texture.

12/2's MERCERISED LINEN. This is the linen used with the white gimp for the checked place mats. Cerise is the only colour we can offer at this give-away price but we have some mats here in the studio woven to this pattern and they do look most attractive. The white gimp gives the cerise linen a soft rosey glow and would fit in with so many colour schemes and I am sure you will decide that they are too good for just picnic purposes. You may have other ideas for the use of this linen - even a plain cotton with it would make excellent glass cloths. The approximate yardage is 1,800 yards to the pound.

16's LINENS IN WHITE. If you made the Canvas Weave luncheon mats given in the last issue of "LOOMCRAFT", you may like to weave serviettes to match. We have some finer linen which should be sett at 28 e.p.i. (or, if you do not possess a 14 dent reed, it could be 24 e.p.i.) and the number of repeats adjusted accordingly. The yardage per pound is approximately 4,800 yards.

SALES AND WANTS.

FOR SALE. "WEAVERMASTER" Loom. Model F.438. As new. Additional parts for conversion to Foot Operation. Books, Shuttles etc., Bargain at £5.
Apply:- Baldwin, 65 Beeston Road, Dunkirk, Nottingham.

FOR SALE. "DOUGLAS ANDREW" Hand-loom with 16, 64 inch shafts and one pedal dobbie. As new. What offers?
Apply:- Jenkins, Drapers, Wexford, Ireland.

FOR SALE. "HOMWEAVE" 15" Table Loom. 4 shafts. Well used but in excellent condition. £5 plus carriage.
Apply:- Cathedral Weaving Centre, 8, Palace Street, Canterbury.

FOR SALE. Small 4 shaft 6 pedal loom suitable scarf weaving and braids. Maximum width 16". Cord healds. 3 reeds, stick shuttles etc., £7.10.0. including carriage.
Apply:- Barber, 71, Old Dover Road, Canterbury.

FOR SALE. "CANTERBURY" Foot Loom 32" width. Good condition. Space necessitates sale. £15. including carriage.
Apply:- Box No.90. c/o "LOOMCRAFT". 8 Palace Street, Canterbury.

FOR SALE. "WEAVERMASTER" Foot Loom. 4 shaft 6 pedals. 38" width. Extra Rug Reed. £18 or near offer.
Apply:- Wells, 54 Park View Road, Lytham, Lancs.

EASTER CLOSURE.

One final word - in view of our participation in the Trade Show from April 25th/27th inclusive, we shall close at the Palace Street premises throughout Easter Week and NO DESPATCHES WILL BE MADE. So, if your requirements are urgently needed please get the order to us before these dates. If it can wait, leave it until early in May. Thank you.

LOOMCRAFT

Single copy 1/3d. post free.

5/- per year inc.post.

BY WEAVERS—FOR WEAVERS—ABOUT WEAVERS

Volume Three.

JULY 1962

Number 2.

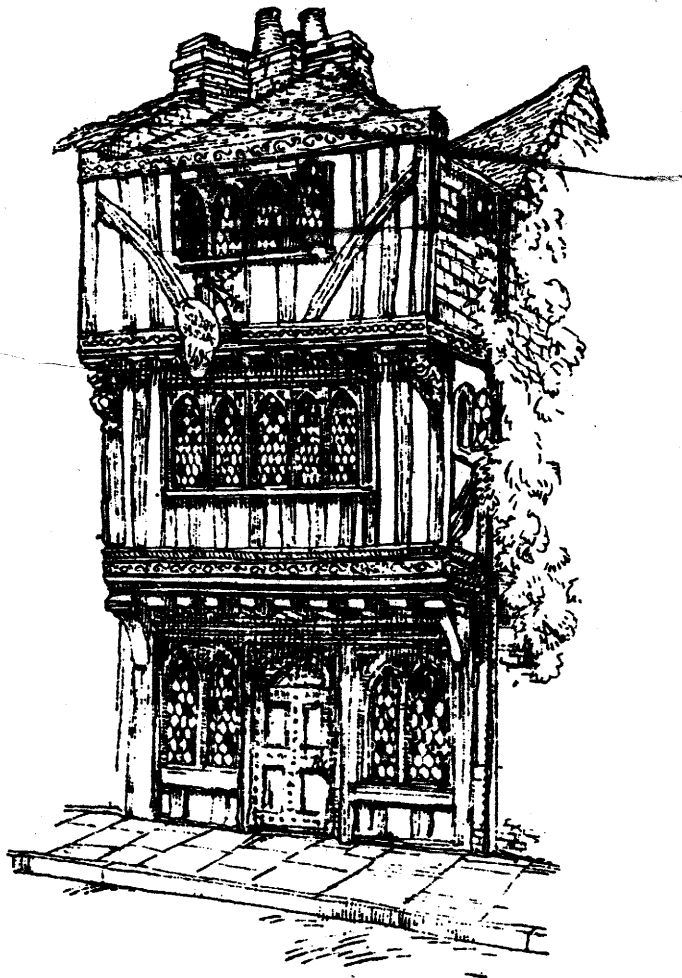

"HOME OF LOOMCRAFT"

Editorial.
"Loomcraft's" New Home.
Gay & Attractive Apron.
Latest Trend for Upholstery.
"Stars" - Another Crackle Weave Pattern.
Cuthil Tweed with Woven Sample.
Cushion Cover from Odds and Ends.
Weavers Quotes.
Report on the Conference.
Talking of Yarns..
Sales and Wants.

"LOOMCRAFT" is issued four times a year - Jan. April. July and October.

8, Palace Street,
CANTERBURY, Kent.

July 1962.

Dear Weaver,

Here we are in the middle of another year! So much has happened in our small world since 1962 came in that the months have slipped by without realising.

We had a very happy and successful time at the Institute of Handicraft Teachers' Conference and saw much in the Craft world to give us food for thought, besides enjoying and renewing old friendships and making new contacts.

Then, of course, we had the excitement of the "Get Ahead" Contest. I attended two preliminary rounds and became eliminated in the round immediately before the Television Heats. I would like to say "Thank you" to all the many kind friends who sent best wishes for my success. It would have been a wonderful opportunity to further the Craft we all enjoy but it seems it was not to be! However, quite a number of strangers contacted me and we have made several new weaving friends.

The Christmas present number of "LOOMCRAFT" will be with you early in October and already we are compiling articles for your pleasures. Please bear in mind that if you have an article you think would be of interest, we should like to see it, and if we like it, a voucher for 10/6d., will be sent to you so that we can use it in a future number.

With best wishes for good holidays and happy successful weaving.

Sincerely yours,

Margaret A. Norris

MARGARET A. NORRIS (MRS.,)

"A NEW HOME FOR 'LOOMCRAFT'."

This may come as a surprise to our many readers, but for some time we have been very conscious of the fact that with the increase of business this building, lovely as it is, is not large enough to house all our stock, and our Workshops being some distance away, rather complicates matters when discussing special equipment.

We expect to have completed our move by August 25th, so from the 27th. of that month onwards our address will be:-

The Cathedral Weaving Centre,
57, Castle Street,
CANTERBURY, Kent.

In our new home we shall have better facilities for teaching, a showroom which will offer better window space, our office lay-out will be all on the ground floor and also our stock rooms and despatch departments will offer even better service.

Also in the same building we shall have our workshops making looms and equipment, all of which we shall be pleased for the interested customer to see.

It is our intention to expand even more than we have done in the past, and also we shall be living on the premises which will give us the opportunity to be on hand at all times.

Now for personal shoppers, here are the details you should observe to find us. If travelling from London (Victoria) by train, follow the signs directing you to the City via the steps leading to Pin Hill; you will then come through St.Mary's Churchyard and find us opposite.

Should you travel by coach, then the Coach and Bus Station will position you at the junction of the main street and A.28; you will see the footpath running round the City wall and into the Dane John Gardens. If you come through the Gardens in front of the Municipal Buildings and along St.Mary's Street, you will find us at the bottom. Should you enter Canterbury on the A.2. then come up to the policeman on pedestrian crossing duty and turn right into St.Margarets Street, then Castle Street is the continuation of this. If you use the A.28 road, then keep left into Castle Street after you have passed under the Railway Bridge at the City end of Wincheap.

Do call and see us, we thrive on friendship! Officially our hours will be 9.30 a.m. until 5 p.m. from Mondays to Fridays, but we shall always be about as it will also be our home.

AN APRON THAT IS GAY AND ATTRACTIVE.

In the last issue I told you that I had received a letter from South Africa asking for tuition on the same lines as that arranged for another weaver some time ago. Well, Miss Roberts has been for her week's tuition and I fixed up for her to stay with the same lady as her friend had done previously.

We enjoyed her company very much and we now have yet another convert to our method of dressing a loom single-handed. It was a delight to see the enthusiasm and to know that one more weaver would not have to rely upon the friend or neighbour to help with a task that is not really their "cup of tea"!

During the studies we set up and made two aprons and several callers have said how much they would like the details, so here they are. Easy to weave and inexpensive to produce.

The warp is made of 6/2's warp cotton, and to produce two aprons make a warp with 379 ends, $2\frac{1}{2}$ yards long. This is threaded according to the draft I have given, and when the loom is fully dressed, the width in the reed is 27 inches.

Weave in plain weave with the white slub and lurex for $\frac{1}{4}$ inches to make the hem and turn up. Now weave the pattern border as given. The remainder of the apron is in plain weave and should measure 27 inches from the commencement, which allowing for the hem turn-up, gives a little over 24 inches.

Now throw a couple of rows of a coloured cotton for a cutting guide to help you when doing the making up. For the waist band weave 2 ins. of plain weave with the white slub and lurex, now weave part of the pattern to give gaiety to the band and finish off with another half inch of plain weaving with the white slub and lurex. Another cutting line should be laid and then weave the second apron in the same manner.

When the weaving is finished, the material should be washed or steam-pressed and then cut into the various pieces and made up as follows. Turn up the hem and sew into position; pleat the top of the apron into the waist-band leaving three inches at each side; insert tapes at each end of the waist-band and machine or handsew into position. Press all seams and pleats. The apron is now ready for use.

For the two aprons it will cost 13/-, but you will have some of the 6/2's warp cotton and some of the slub and lurex left over for the article you will find on Page 8 of this number on using up odd pirns of yarn.

The Draft for this will be found on the insert enclosed with others in the magazine.

A GAY AND ATTRACTIVE APRON.

Use a 14 dent reed single sleyed and single through the healds.
Warp 379 ends, 2 1/2 yards long. Standard tie-up for pedal looms.

Threading Draft.

4	4	4 4 4	4	4 4 4	4	4 4 4	4 4 4	4	4
3 3	3 3	3 3	3 3	3 3	3 3	3 3 3 3 3 3	3 3	3	3
2 2	2 2	2 2	2 2	2 2	2 2	2	2 2	2	2
1 1	1	1	1	1	1	1	1	1	1

Selvedge Section B Section A... Selvedge. Shafts.
7 ends. 31 ends. 13 ends. 7 ends.

Weaving Lifts.

<u>Shafts.</u>	<u>Pedals.</u>	<u>Times.</u>	<u>Shafts.</u>	<u>Pedals</u>	<u>Times.</u>	<u>Shafts.</u>	<u>Pedals.</u>	<u>Times.</u>
3 - 4	5	4	1 - 4	6	1)	1 - 4	6	1
2 - 3	2	2	1 - 2	1	1)	1 - 2	1	1
3 - 4	5	4	2 - 3	2	1)	2 - 3	2	1
			3 - 4	5	1)	3 - 4	5	1
Now weave 8 rows of plain weave with white slub.			2 - 3	2	1)	2 - 3	2	1
			1 - 2	1	1)	1 - 2	1	1
			1 - 4	6	1)	1 - 4	6	1
			3 - 4	5	4 ,			

Weave above twice.

Now weave 8 rows of plain weave with white slub.

Weaving Lifts (contd.,)

<u>Shafts.</u>	<u>Pedals.</u>	<u>Times.</u>
3 - 4	5	4
2 - 3	2	2
3 - 4	5	4

A binder row follows each pattern row.

Threading Guide.

Selvedge	7
Section A & B (44 ends X 8)	352
Section A (once) ...	13
Selvedge	7

379 ends.

THE LATEST TREND IN UPHOLSTERY FABRICS.

It is becoming quite the fashion to have tweed materials for furnishing fabrics, and this reminds me of a customer I had very early in my weaving activities. Her husband came with her to choose Tweed Yarns and I was very surprised at the bright and varied colours they were selecting. I thought it was to be a Sports Jacket, so you can imagine my astonishment when they told me it was for recovering a favourite chair! They had a check pattern and repeated the colour range of the warp in the weft. When it came back to me for the finishing service I was still a little perplexed about the eventual result, but after it was all done I did see that masterpiece and it really was most attractive in the contemporary surroundings of the sitting-room.

Since I have been in Canterbury I have had several other lengths for chair seats, but never a full armchair. Now, I see the modern three piece suites are getting just this finish, and the Latex rubber foam cushions which are being used and covered to match, make it a very worthwhile idea.

Some of the fabrics are woven in plain weave, but I have seen several using the twill weave which, of course, takes a little more yarn and it is, therefore, a little closer by virtue of the two ends lifted with each pick.

If your loom will take 32 inches width or more, work on the following calculations. For plain weave sett at 14 e.p.i. and allow 450 ends - this will need 8 ounces for each yard woven. If, however, you decide to make it thicker, then sett at 16 or 18 e.p.i. but do be sure that with this setting you are able to beat enough to obtain a balanced weave. Your lifts will be 1 & 2, 2 & 3, 3 & 4, and 4 & 1, repeated. This will give you Twill Weaving and will take 10 ounces per yard length and you will need either 514 ends for 16 e.p.i. or 578 ends for an 18 dent reed. If you have a coarser reed which will give you any of these settings, I would suggest that you use one of them so that it is less trouble to sley and also much kinder to the warp.

To my mind, the most suitable yarn would be Harris type 9 cut, but you could use the Tweed Mixture which we have on offer at 8/- per pound as the weft on a tweed warp and so cut the cost. (You may remember that this was suggested for the weft of the Travelling Rugs article in "LOOMCRAFT" sometime ago). All the colours in this yarn are varigated but a stamped, self-addressed envelope will soon bring you samples. The Harris yarn is, of course, in plain colours and a wider variety - here again samples will be sent on request.

The finished material will then, of course, need scouring etc., and we shall be very happy to carry out this service for you. The charge for this being, 1/9d. per yard or part of a yard, plus the return postage, allowing a week or ten days.

"STARS" - ANOTHER CRACKLE WEAVE PATTERN.

The Crackle Weave Pattern which we gave you about two years ago called "GOLDEN CROSS", is still proving so popular that we feel a further pattern on these lines would be useful. Several of our friends remarked that they liked it when we were using it at the Trade Show last Easter. Since then, we have been weaving up the warp in the Showroom and it has been greatly admired. So, here you are!

The warp and weft binder are 12/2's mercerised cotton - the weft pattern yarn could be the Rayon Crepe Twist or a new Rayon Yarn we have just introduced which is about the thickness of Lyscordet. You should use a 14 dent reed and double sley it to give 28 e.p.i. Let us suppose that you are going to weave a table runner with a finished measurement of 36 ins. long by a little over 12 ins. wide. The warp should be a little over 1½ yds long with 363 ends in it. Dress your loom as usual using the threading given, slewing the reed double but single through the healds throughout.

Threading Draft.

```

      4 4 4      4 4 4 4      4 4 4 4 4      4
      3 3 3 3 3 3 3      3      3 3 3 3 3 3 3      3 3
    2 2 2 2 2 2 2 2 2      2 2 2 2 2 2 2 2 2      2 2
  1 1      1 1 1 1 1 1 1 1 1      1 1      1 1      1
  
```

Pattern..... 60 ends 5 times,(300 ends)..... Border Selv.
5 times 30 ends.

Threading Guide.

Border Selvage ...	30	4	4 4
5 Full Patterns ...	300	3 3	3
Link... ..	3	2 2	
Border Selvage ...	<u>30</u>	1	
	<u>363</u> ends.	Border Selvage.	Link (once)
		5 times (30 ends)	

Weave a plain hem at either end with the binder thread using shafts 1 & 3 and 2 & 4 alternately (½" will give a 2" hem when made up). The pattern weaving is quite straight forward and should be repeated until the length required is obtained, finish off with a hem to match the beginning. A binder row follows each pattern row.

Weaving Lifts.

<u>Shafts</u>	<u>Pedals</u>	<u>Times</u>	<u>Shafts</u>	<u>Pedals</u>	<u>Times.</u>
1 - 2	1	4	1 - 2	1	2
1 - 4	6	4	1 - 4	6	2
3 - 4	5	6	2 - 3	2	6
2 - 3	2	6	3 - 4	5	6
1 - 4	6	2	1 - 4	6	4

Finish last repeat with shafts 1 - 2 (Pedal 1) 4 times to balance weaving. Materials required 4 oz. 12/2's Mercerised Cotton for warp and binder, and 2 ounces of Rayon Silk on the new 1.oz. tubes. (See Standard Stock List enclosed).

"WHAT IS CUTHIL TWEED?"

Hardly a week goes by without this question cropping up amongst the requests for samples of our weaving yarns. I suppose it is rather a strange name but I do not know how it arose; I can only tell you how it weaves and wears which, after all, is the thing that matters most.



We obtain all our tweed yarns from a firm of Spinners in Scotland so I can only suppose that it may be a name peculiar to that part of the country. Our Harris type yarn is a sturdy tweed yarn which does not have those many hairs which I find very difficult to contend with when weaving, and also, when our materials are returned from the finishers, it is a firm cloth very suitable for hard wear and long service. Our normal weight for Harris type yarn is 9 cut.

In the range I can call upon, the next size up is a 12 cut Cheviot, but the range of colours is not very great so I do not offer this on the Standard price list. To my mind this is a finer version of the Harris 9 cut.

The finest yarn is the Cuthil 20 cut and this is a sample of this yarn which was sett at 24 e.p.i. then finished in the normal way. The setting is the plain weave setting of 1, 2, 3, 4 repeat, and the shaft lifts were those for twill - 1 & 2, 2 & 3, 3 & 4, 4 & 1, repeat, but you can of course, use the Beauchamp twill lifts if you wish to have a skip twill instead.

Before the cloth is sent to the finishers to be scoured and processed, we find that for a square yard it is safest to calculate 7 to 8 ounces for both warp and weft. The approximate yardage per pound weight is 4,000 yards, and if double sleyed through a 12 dent reed it weaves very easily. I do not advise setting tweeds too close, it is difficult to get a clear shed, hard to beat down and when the cloth is finished it is so close and thick that the fibres cannot move easily and this restriction is a sure way of asking for the elbows and cuffs to wear and fray. I was once told that the test for well-woven tweeds is to be able to push a pencil through the cloth and when the pencil is removed, the fibres should return to their correct positions very quickly.

At the present price of 21/4d., per pound, it is possible to weave a length for a Sports Jacket for £2.0.0. plus the finishing charge.

I do hope that you will keep this yarn in mind for some future date when you are thinking about tweed weaving again. If you want a particular colour, please send me details of it and I will try to obtain it for you if it is not in our range on offer.

Continued overleaf on Page 8....

A CUSHION COVER FROM ODDS AND ENDS.

Whilst we were at the Conference of Handicraft Teachers' Trade Show, several of our visitors brought up the age old subject of the odd pirns and part tubes of yarns which everyone collects when weaving. I explained that the best way of using these up was to put on a warp using several odd ends of threads, but of a similar thickness.

Suppose we decide to make a square cushion cover of 18 inches and the threads we are going to use for the warp are 6/2's or Lyscordet. A fourteen dent reed will be needed having 260 ends which should be $1\frac{3}{4}$ yards long. The healds should be threaded singly throughout, but the reed needs four double at each selvedge, and the rest of the reed should be single sleyed. If you thread "Rosepath" as near as possible, or "Modified Goose Eye", it will give interest to your weaving.

Now, using either two shuttles or a double shuttle, put pirns in which are of different colours and if you wish, of different textures. If two shuttles are used they are thrown from opposite sides in the same shed, but with a double shuttle, and of course, there is only one pick per shed. The fine thread for binder is used in the normal way. I would suggest that you use a fine thread - 12/2's or 16/2's as a binder, then using the twill lifts you will obtain a pretty sawtooth pattern with the colours you are using up, each lift followed by a binder on 1 & 2 or 2 & 4. When either of the pattern pirns run out put in a totally different pirn so that the remaining thread has a new partner. In this way the colours are mingled and it does not matter how many different colours are used in the same piece of weaving. It all depends upon your method of pairing up the odds and ends.

Continue in this way until you have woven enough for your cushion cover, both sides, then it should be made up ready for use.

Don't be afraid to use wool as well as cotton, but do put one pirn of wool with one pirn of cotton, and as far as possible, see that a thick yarn is used with a thin one to balance up.

CUTHIL TWEED (continued from Page.7.)

The final word - we have mixed Harris 9 cut with Cuthil 20 cut and found it very attractive. It looks good when used in this way for a checked design, say four threads of Harris and then two of Cuthil in another colour. Use a fourteen dent reed, single sley for Harris but double sley the Cuthil, single through the healds throughout of course. Lay the weft to correspond with the warp threads to obtain a balanced check.

WEAVERS' QUOTES.

As you will always see on our front cover, "LOOMCRAFT" is a magazine produced by weavers, for weavers and about weavers. So, the following remarks are from a few of our weaving friends and I feel sure that they will be of interest to you.

One of our older readers, Mrs.S.Broughton of Yeovil, writes:- "As my hands have become very shakey, I'm unable to do much weaving though I keep in a little practice on my loom, as a therapy steadier. My interest is as keen as ever and the arrival of "LOOMCRAFT" thrills me. How I wish I were in the forties! "

Now this from a very dear friend of ours and it may be of interest and help to some of our readers who are in the same position as she is. Mrs.Netta Musket of Putney, London writes:- "I have arthritis of the hip and my Doctor advises gentle exercise of the joint without putting undue strain on it and stopping immediately I am in pain. Treadling my "Chiltern" Loom is the perfect answer!"

Mr.H.G.Bowles of Bletchley, Bucks writes of success in another way:- "I am pleased to report that at a recent local Handicraft Exhibition, I was awarded the Silver Cup (only small, of course!) for the best exhibit in the Show - a Traditional Tartan Stole. As I was told the Judges were unanimous and there were numerous classes of work, you can imagine how pleased I was. I thought you'd like to know". Of course we were pleased to know and wish you all success in these ventures.

Sometimes, after we have given an article in "LOOMCRAFT", many of our readers write to tell us of their ideas of using our suggestions and we think it only fair to pass their comments to you. Firstly, Mrs.M.S.Hedges of Market Harborough says, "I found Pem's Fancy" in the last issue of "LOOMCRAFT" made a lovely little pattern for a bookmark! I want to try so many things and will be sending for more yarns later." Secondly, two more of our readers wrote with the same idea for making book-covers. Mrs.Brown, of Ballymoney, Northern Ireland writes, "I am having fun with my "Palace" and my book-cover is coming on nicely". This, by the way, she is weaving in Golden Cross pattern, as is Mrs.Stordy of Cheltenham who says, "The book-cover for my new English Bible, using the "Golden Cross" design, looks lovely". In view of the popularity of this particular pattern, I have decided to include in this same issue an advanced Crackle Weave pattern on these lines and I do hope you are going to try it and have as much success with it as with the "Golden Cross".

We cannot resist including a few of the many compliments to our little magazine! Mr.Herbert Marshall, of Penn writes:- "I always count this as one of my pleasantest duties when I send along the annual subscription for a future supply of "LOOMCRAFT". I enjoy its reading, I enjoy its suggestions, and again I look forward to twelve months of pleasant interest as the new copies arrive". Miss Elsie Humphris of Colwall also expresses her approval - "I should be very sorry to miss receiving it, as I enjoy reading each number as it arrives.

THE TRADE SHOW AT THE NATIONAL INSTITUTE OF HANDICRAFT TEACHERS'
CONFERENCE.

How nice it was to see so many weavers we hear from but seldom see! We made a lot of new friends and contacts which are now beginning to bear fruit.

Altogether it was a very interesting week - lots of hard work preparing for it, plenty of talking and demonstrating during the actual Show, then came the dismantling of our exhibits. However, all hands on deck and we cleared by about 8 o'clock on the Friday and spent most of the weekend putting things away at "home". We were well pleased with it and our only regret was that our long-distance friends missed a fine showing of many crafts other than weaving.

BOOKS FROM AMERICA.

On the back page of this issue you will find a list of some old friends and the introduction of some new ones. I am very glad to announce that "Weave your Own Tweeds", by Millen is available again but, of course, not at second-hand prices! An old friend for some people is "Four-Harness Huck", by Neher; this is a very fine reference book (patterns) for texture weaves - a boon to the established weaver looking for something different.

A new book, to me, is "Heritage Linens", by Young. This is a subject which always bears new discovery, and in this book I was delighted to find a brief history of the American Early Weaves and yarns then in vogue. So many of the old techniques are suitable for modern weaves and it seems such a pity to let them become museum numbers. After all, linen will outlive wools and cottons, not to mention man-made fibres, and the more it is washed and laundered, the nicer it becomes. Not a present for the beginner, but a very useful gift for the advanced weaver who treasures books of this kind.

TUITION.

If you are thinking of a few days break in the Autumn or early Winter, why not come to Canterbury for a revisionary course of weaving? When we are settled in our new premises we shall be able to offer you better accommodation in our new studio. It would make a pleasant break when seaside holidays are not always attractive. Write and tell us what you would like to study and we will work out a syllabus for you. Also, at this time bookings at Guest Houses or Hotels are much easier. We estimate a short course of 14 - 15 hours, spread over three days, can give you a wealth of new ideas and techniques, costing £5.5.0. plus a little for any yarns you may use.

"TALKING OF YARNS....."

RAYON GIMP. (medium thickness)

This yarn is very attractive and useful for many weaving projects. In off-white only, so I dyed some to see what the result would be - the dyed yarn was even more attractive than in the 'grey'. As I needed some maroon yarn for a couple of small curtains, I bought a dye and followed the instructions given; the colour is perfect and I appear to have lost about two inches on the overall length of the hanks, so it is not a very great loss. The hanks are approximately $2\frac{1}{2}$ ounces and the yardage before dyeing was a good 230 yards. So, it is still a good investment at 1/3d., per hank.

COLOURED COTTON OF 7/7's TEXTURE.

Only two colours in this unfortunately - Black and Scarlet (apart from unbleached) but an ideal yarn for rugs etc., also most suitable for coarse table mats using it as spaced warp with $1\frac{1}{2}/6$'s soft cotton for the weft. A well spun cotton yarn and useful for many purposes. We are prepared to wind off $\frac{1}{2}$ lb. hanks (at 8/- per pound) but not less than this amount.

MAYGROVES YARNS.

Although it is over three years since Maygroves ceased to supply weaving yarns, we still get customers quoting their numbers and complaining that it is not possible to match up yarns they purchased several years ago. Now we do sympathise with these friends but it is a situation which is most unfortunate. So, please bear with us and if you are one of these people, we can offer you a very near match in most cases and hope that this will satisfy your needs.

BONUS VOUCHERS.

With our last number we introduced the idea of a bonus scheme for our readers. We send you a voucher slip for $2\frac{1}{2}\%$ of the purchases on the invoice it accompanies (under 5/- we cannot really make out a voucher - the amount would be so small). When you have collected 2/6d. worth of these vouchers, return them with your next order and we will deduct the amount from the purchase you are making at the time. Please do not send in a payment less your vouchers - this puts our book-keeping out of gear; we must have the vouchers back and deal with them ourselves. Many thanks.

SALES AND WANTS.

FOR SALE. 42" Foot Loom 4 shafts 6 pedals. £15.
36" Harris Table Loom 4 shafts. £7.
Space urgently needed. Can be seen at Worthing, Sussex.
Apply:- Box No.91. c/o. "LOOMCRAFT". 8, Palace Street, Canterbury.

FOR SALE. 30" ELEX Loom with equipment. £8 or near offer.
Apply:- B.Newton, 3, Collington Mansions, Bexhill, Sussex.

FOR SALE. 42" DOUGLAS ANDREW 8 shaft loom. Practically new. £25. Viewing
by appointment only. Apply:- Lockwood, 23, Second Avenue, Shotgate,
Wickford, Essex.

FOR SALE. 15" WEAVERMASTER Table Loom. 4 shaft. £3.
Apply:- Pratt, 168, London Road, Teynham, Kent.

FOR SALE. 12" 4 shaft Table Loom. £4. As new.
36" & 42" 4 shaft 6 pedal Foot Looms. £5 and £10.
42" Loom with Fly Shuttle Race. £40. Excellent condition.
Apply:- Digby Stuart College, Roehampton. S.W.15. These are surplus to
needs due to re-organisation.

FOR SALE. 36" Tableloom 4 shaft. Wire Healds, cloth and Rug reeds.
Accessories etc., Apply:- Isaacs, 105, Earls Hall Avenue, Southend-
on-Sea, Essex.

WANTED. Weavers capable of producing Headsquares in 2/24's Fine Wool.
Details to:- Cathedral Weaving Centre, 8, Palace St., Canterbury.

AMERICAN BOOKS JUST TO HAND.

"Handweavers Pattern Book", by Davison... .. 55/- p.p.2/6d.
"Shuttlecraft Book of American Handweaving" 55/- p.p.2/6d.
"Weave your Own Tweeds", by Millen... .. 35/- p.p.1/-

NEW TITLES ON OUR SHELF.

"A handbook of weaves, by G.H.Oelsner. 42/- p.p. 2/6d.
"Four-Harness Huck", by Evelyn Neher.. .. 21/- p.p. 1/-
"Heritage Linens", by Helen D.Young... .. 14/- p.p. 1/-

LOOMCRAFT

Single copy 1/3d. post free.

5/- per year inc.post

BY WEAVERS—FOR WEAVERS—ABOUT WEAVERS

Volume Three.

OCTOBER 1962.

Number 3.



Editorial.

Black is so Smart.

A Christmas Gift for
Your Church.

A Fringe for the
Book-Marker.

Maltese Cross.

A Chequered Towel -
With Sample.

Bathmats with a
Difference.

Make your Own Xmas
Cards.

Knee Rugs for the Car.

Special Xmas Offer.

Do you know that?

Sales and Wants.

"LOOMCRAFT" is issued
Jan. April, July & Oct.

57, CASTLE STREET, CANTERBURY, KENT.

Tele. Canterbury 3935

57, Castle Street,
CANTERBURY.Kent.

October 1962.

Dear Weavers,

We are now in our new home. It was quite an upheaval but all those friends who have managed to visit us since we settled in say how much they like the change. We have more space and all the rooms are so much lighter.

Many, many thanks for all the delightful cards and goodwill messages we have received - we had no idea we were so popular!

You will find several items in this issue of "LOOMCRAFT" which are intended for your interest in connection with Christmas, now so near to hand again. I am hoping that you will see just the ideas you have been looking for.

Also, I would like to draw your attention to our Special Special Offer list - this may be useful to you when planning your handwoven gifts.

We have found that this little magazine has been the medium of bringing many weavers together and many of them have become life-long friends. Now, I wonder if I could ask any of you living in or very near Broadstairs, whether you have an hour or two per week to spare to help one of our weaving friends who lives alone there. He is blind and would appreciate any help that could be given to him when setting up his loom. He is a most cheery soul and a warm welcome is given to all who call. If you feel you would like to pay him a visit, his name and address is:- Mr.J.Hewitt, 7o Stanley Road, Broadstairs, Kent.

Now I must once again say how much I hope all our readers will have a successful "weaving spree" preparing woven tokens for the Festive Season, and finally, that everyone will have a Very Happy Christmas and a Prosperous New Year.

Sincerely yours,

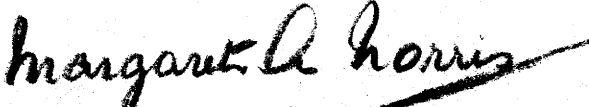
Margaret A. Norris (Mrs.,)

BLACK IS SO SMART!

Something quickly made yet madly interesting is always a problem at Christmas time. One year I decided that my very special friends should have a "Christmas card" that would last and be useful long after the decorations were taken down. I gave small tray cloths just large enough for the early morning tray, and I know that some of them are still in constant use after ten years! So, here is a simple pattern which you can use and from the instructions I am going to give, you can make three tray cloths or four place mats for only 8/-.

Here is how it can be done. You will need $\frac{1}{4}$ lb. of 12/3's for the warp, $\frac{1}{2}$ lb. of Black Boucle for the pattern weft, and a $\frac{1}{4}$ lb. tube of coloured 6's Rayon for the binder thread. These will cost just 8/- (plus postage) and you will have quite a lot of the 6's Rayon left for your store cupboard.

Lay a warp 459 ends (21 inches) by 60 inches long and dress the loom in the usual way using the draft we are giving, remembering to sley a 14 dent reed single and double alternately, except for the first and last four dents which should be all doubles. The healds are single throughout.

Set the web using as little warp as possible and then follow the lifts as given. If you are making three tray cloths then weave as near as possible, with a balanced pattern, to 14" as you can get. Put in a warp lath or use thick waste cotton to give 1 - $1\frac{1}{2}$ inches and then weave the same length of pattern again. Make the division again, and then weave the third tray cloth. After this has been completed, throw 4 or 5 rows of waste to hold the weaving until the making up is completed. Follow the same procedure if you are making four place mats, but only weave approximately 10 inches instead of 14" to give you the four mats.

When you have removed them from the loom they need finishing. This is carried out either by drawing a thread all round, about $\frac{1}{2}$ " in and machining in the space, or by hemstitching about $\frac{1}{2}$ " in all round and then removing the surplus warp and weft threads to give a fringe all round. Steam press and if possible put in a polythene bag to give them the professional touch. One cushion cover can also be produced on this length of warp. Here the weaver should make a plain weave heading of 1" and then weave 40" in pattern, finishing off with another inch of plain weaving. Turn down the plain at either end to form the hems, join up the sides and either put in a zipp fastener or press studs to close the pad.

DO YOU KNOW WHAT A DENT IS?

Dents are metal or wooden strips or teeth composing the reed. Also, the spaces between the teeth through which the warp threads are passed after leaving the healds on their way to the cloth beam. The number of dents or spaces per inch is said to be the size of the reed; i.e. a No.10 reed has ten dents per inch; a No.20 has twenty etc.,

A CHRISTMAS GIFT FOR YOUR CHURCH.

Recently I was asked to weave 10 Book Markers for a local Church. As it was a business deal and not a gift from me to the Church in question, I asked what they thought they ought to cost. To my amazement I was told that one measuring 48" x 1½" with plain gold Crosses at either end and heavy fringes, made of mercerised cotton, would be 48/6d! I therefore promised that even the 48" ones would not cost anything like this figure and would be handwoven in pure silk.

Several friends have asked for details of this so I thought perhaps other people would like to try these for themselves.

Allow one ounce of silk for each yard of warp and weft, but if you do several it will come out cheaper than this, say 3 yards from 2 ounces. Make a warp of the length you need, being generous so that you can afford to play around at the beginning to get good selvages and an even beat. You will need 88 ends and this is sleyed three to a dent using a fourteen dent reed, except for the first and last two dents which take four each. The threading is simple - 1, 2, 3, 4 throughout. I use a small shuttle that I can close my hand around and control the weft tension. Also, you need a smooth flat stick about ½" wide by 6" long to pick up the warp ends when making the pick-ups to give the Crosses at either end. A small quantity of gold floss is needed for the pick-up work - we can supply you with enough for two Crosses for 6d if you have nothing suitable by you.

When you are satisfied that your edges are good enough, then weave a couple of inches in plain weave. Now it is time to lay the first Cross in. Make a "butterfly" with the gold silk, or do as I do and wind enough for the Cross on to a lace bobbin.

The actual warp width is 28 dents of your reed, so the 6 threads which are entered through 14 and 15 are the middle. Now I raise shafts 2, 3 and 4; this gives 5 threads up with 2 on one side of the dormant middle thread and 3 on the other. Now pick up on your pick-up stick these 5 plus one more on the side raising only 2, so having 3 threads on either side of this one which is virtually the centre. If it helps you to check more easily, then it is 40 threads on one side, 3 on a pick-up stick, 1 missed, 3 on the pick-up stick and 41 at the remaining side. Turn your stick on its side and pass the thread to be laid in through the extra shed made. I always enter the cross thread so that when I throw the pick of self colour, it returns to the side from which the laid-in thread began. Beat in the usual way after changing to the plain weave shed and throwing the pick of self colour. Repeat the laid-in thread, followed by a plain weave pick until 32 rows of the gold have been woven in. Now on the same principle lift 30 threads - in other words - 12 on either side of the 6 just used, remembering that after every third end lifted, one is left and not counted. Make 6 picks with the gold on these 30 ends then return to the original 6 and make a final 10 picks which is the head of the cross. Always remember that a plain weave row follows a laid-in thread.

Continued on opposite page....

A CHRISTMAS GIFT FOR YOUR CHURCH. (contd.,)

About 30" - 31" of the plain weave now follows, and then the second cross is laid in but in the reverse order - 10 on the middle six, 6 on the middle 30 and 32 on the middle six. The matching 2 inches finishes off the book-marker.

You can either make a small fringe of the warp ends or weave a fringe according to the next article in this issue of "LOOMCRAFT".

A FRINGE TO FINISH OFF THE BOOK MARKER.

This is something of a "fussy" job, so if you are in a hurry to get finished, then I fear you will find it irksome.

There is rather a waste of warp unless you need several pairs (they are in pairs - one for each end). The warp takes 24 ends and once more the 14 dent reed is used. When your warp is ready, it is divided into two 12's. One lot is threaded on shafts 1 & 2 and the other on shafts 3 & 4. Three to a dent and sett in the reed so that it is central with a space in the middle of 4 inches with 12 ends at either side. You need two shuttles with yarn to correspond with the warp for the two wefts, and another shuttle preferably a stick type, for the thicker weft of which the fringe is woven. I use Rayon Crepe Twist but you may have other ideas. It should of course be fairly thick to give weight.

Now, after a small heading has been woven to set the warp, proceed as follows:- raise 1 & 3 and make a pick of the Rayon Crepe Twist, now raise shaft 1 and with the finer yarn make a pick through the shed given. Next, raise shaft 3 and with the other fine yarn shuttle make a pick. In other words, you are weaving two warps at the same time with a common thick weft for them both. Now use the shed to give you 2 & 4 and make another pick right across with Rayon Crepe Twist. It is now the turn of shaft 2 on one warp and shaft 4 on the other using the fine wefts. Continue alternating the shafts and threads for the length required. The fringe should embrace the book-marker covering the back as well as the front.

When you have finished and removed from the loom, the fringe should be cut down the exact centre to give two pieces, each with a neat and nicely woven heading to fix on to the book-markers. I do hope you will enjoy doing these.

The warp and binder weft is the same as the book-marker and does not take very much. For the thick weft a pair of fringe ends will take 12 yards of Rayon Crepe Twist, or 1.oz of the Rayon Crochet yarn at 1/3d., would be sufficient for three or four pairs. We can supply the Rayon Crepe Twist at 9d., which is enough to make one pair.

KNEELERS IN MALTESE CROSS PATTERN.

Warp 614 ends $2\frac{1}{2}$ - $2\frac{3}{4}$ yards long. Sley reed double through 14/1 reed, 22" wide to give 28 e.p.i. with W.W. Light Blue 12/2's mercerised cotton. Single threading in healds. The pattern thread is W.W. Dark Blue 6/2's.

THREADING DRAFT.

4		4		4 4 4	4	4	4 4 4	4	4	4
3	3		3 3 3		3	3	3 3 3		3	3
2	2		2 2 2		2	2 2	2		2 2 2	2
1		1 1 1		1 1 1	1	1 1 1		1 1		1

3 times Bal. Pattern (42) ends. 3 times
 12 ends (1) Thread 14 times 588 ends. 12 ends. Shafts.

Binder row of 12/2's mercerised Light Blue after every pattern row of Dark Blue, repeating lifts for length required.

SHAFT LIFTING.

<u>Shafts.</u>	<u>Times.</u>	<u>Shafts.</u>	<u>Times.</u>	<u>Warp Split.</u>
3 - 4	1	2 - 3	1	Selvedge ... 12
2 - 3	1	1 - 2	1	14 Patterns. 588
1 - 2	1	1 - 4	1	Balance ... 2
1 - 4	1	3 - 4	2	Selvedge ... 12
3 - 4	4	4 - 1	4	
2 - 3	4	1 - 2	4	Ends ... <u>614</u>
1 - 2	4	2 - 3	4	
1 - 4	4	3 - 4	4	
3 - 4	2	1 - 4	1	
1 - 4	1	1 - 2	1	
2 - 3	1	Now start at the beginning again.		
3 - 4	1			

Beating should be firm and even.
Binder rows are 1 - 3, 2 - 4, alternately.
 It is a good policy to weave about $\frac{1}{2}$ " - 1" plain weaving at the beginning and end of length required.

This is an all-over pattern which should be firmly beaten to give a strong hard-wearing fabric. If you are simply weaving tops for existing kneelers then you must adjust accordingly, but the above measurements are given to produce four kneelers, approximately 17" x 11" with a 2" depth all round. I suggest $\frac{1}{2}$ " of plain weaving at the beginning and end of each piece, then a good 15", or as near that as possible, bearing in mind the pattern lifts.

For four kneelers you will need $\frac{3}{4}$ lb of 12/2's W.W. and 1.1b. of 6/2's W.W. mercerised cotton. These amounts are on the generous side.

WEAVING INSTRUCTIONS FOR "BLACK IS SO SMART".

Threading draft.

4		4 4 4	4	4	4 4 4		4		4
3		3 3 3			3 3 3		3		3
2	2	2 2		2	2	2	2 2 2		2
1	1 1		1 1 1 1 1 1 1 1				1 1		1
<u>Selv.</u> (4)	<u>Bal.</u> (3)		<u>Pattern</u> (32 ends)				<u>Selv.</u> (4)		<u>Shafts.</u>

Warp analysis.

Standard tie-up for foot looms.

Selvedge... ..	4	Pedal	1	Shafts	1 - 2
14 Patterns (32)...	448	"	2		2 - 3
Balance	3	"	3		1 - 3
Selvedge... ..	4	"	4		2 - 4
	-----	"	5		3 - 4
	459 ends.	"	6		1 - 4

Binder rows are 1 - 3 and 2 - 4 alternately.

Shafts. Times.

1 - 2	2)	
2 - 3	3)	Repeat throughout.
3 - 4	5)	
1 - 4	4)	Binder row after each pattern row.
3 - 4	5)	
2 - 3	3)	

At the end weave 2 rows of Shafts 1 - 2 to balance weaving.

For a small border with a plain weave centre, I would suggest the following simple pattern:-

Shafts. Times.

1 - 4	2)	
3 - 4	2)	
2 - 3	2)	
1 - 2	2)	Binder row follows
2 - 3	2)	each pattern row.
3 - 4	2)	
1 - 4	2)	

A CHEQUERED TOWEL.

This can be made on a two shaft loom if a four shaft loom is not available. A 7 dent reed is needed, anything finer will not be suitable as the Snarl used as part of the warp must have a clear passage through the dents.

Working on the finished measurements of 24" x 36", you will need $\frac{3}{4}$ lb of snarl and 4oz of 6/2's cotton, all in Apple Green.



Lay a warp measuring $1\frac{1}{2}$ yards as follows:-
8 cotton, 4 snarl, repeated 22 times and finish with another 8 cotton.

Plain threading single through the healds, but the cotton is double sleyed in the reed, the snarl single sleyed. This gives four dents of cotton and four dents of snarl.

The weaving is plain tabby, using the cotton for $4\frac{1}{2}$ " to give a hem, and then 4 rows of snarl, 8 rows of cotton for 34", finishing with 4 rows of snarl. Now repeat the $4\frac{1}{2}$ " of cotton for the other hem. Turn the hems down and sew. Now soak in rain water for 24 hours and hang up to drip-dry. If you still need to launder it, do so, and it is then quite ready for use. This will cost 9/6d. for one towel with years and years of wear in it.

Another good idea to use with the above instructions is to make a Bath Mat to match. First buy a piece of foam rubber the size you require for your particular bathroom. Weave enough material to make a 'bag' to fit this, slip the foam into it, and either sew or use press-studs to close the ends. This is so easily removed for laundering when wash-day comes round, and will again give you lots of hard wear. Remember when calculating the amount of yarn required that the towel measurements were 24" x 36", so order your yarns accordingly.

Having made the towels and bath mat cover for your bathroom, now go all the way and weave the curtains to match! The same type of weaving will look nice or you can make the warp with less snarl and more cotton, say 2 ends of snarl and 2 picks of it in the weft, but with more cotton ends and picks to give a larger check.

We have made cloakroom curtains and roller towels with snarl and cotton warp but the weft is all white gimp. In this way the snarl gives a stripe only - very smart and a good medium for drying hands!

Do experiment all you can - I am sure you will find lots of interesting ways with which to use the snarl and gimp in the warp and it gives so much more variety than using these yarns in the weft only.

BATH MATS WITH A DIFFERENCE.

About three years ago there was a great interest taken in the all-plastic Bath and Kitchen Mats which were just reaching this country from Sweden. We were approached by two firms anxious to give the Home Market something of a like nature made in Britain. This we were able to help and advise upon and now there is a steady output in not only mats for domestic use, but for beach mats, toilet bags and now I understand, sandal tops for beach wear. At first sight the warp for this kind of thing can be rather frightening, but taken in easy stages and exercising care it can be done, and some very attractive handwoven articles produced.

You will need a 14 dent reed which is sleyed every other one, giving 7 e.p.i. If you only have a 16 dent reed, then use this in the same way but put on extra ends to give you 21 inches reed width.

Lay your warp with a cross in the usual way avoiding twists in the $\frac{1}{2}$ " plastic tape as much as possible, although some will slip by. You will need 147 ends and these should be $2\frac{1}{2}$ yards long to give two mats 20" x 30" finished. Remember to tie the warp well so that you can easily pick up the cross.

I advocate threading from the front of the loom, sleying the reed first and then threading the healds. Let me say here that the ordinary "Weavemaster" wire healds are not suitable for this material. If this is your first attempt at threading from the front of the loom, I would suggest that you carry out this simple method. The cross should be at the end of the chain taken from the warping frame or mill, not the beginning. Place the cross on the palm of the hand with the first finger above the cross and the little finger below the cross. These two fingers should have half the warp in front of the fingers and half behind, so that passing through the cross, those warp ends on top of the little finger are behind the first finger and vice versa for the remaining warp ends. Now, cut the extreme ends of the warp beyond the first finger and also the various ties on the warp. In this way each warp end will present itself by lying on top of the cross (finger tip end). With a threading hook inserted in the appropriate dent from behind, draw the warp ends through in strict sequence. Once the end is through a dent leaving 8 - 10 inches behind the reed, it should be released from the hand. Continue in this way until all the warp is through the reed.

Now, either turn the loom round so that the back now faces you, or sit at the back. Most looms are built so that the hack bar is removable, this will enable you to either sit in the loom if it is a large foot loom, or lean over it if it is a table model. When using a "Kentish" I always get in between the warp roller and the shafts, but it means stooping. Now draw the warp ends through the healds in pattern order for "Rosepath", remembering that the No.1 shaft is farthest from you. I always work in eights and check each pattern before straightening up the ends, and in the case of plastic, I use a small stapler to clip them together. Don't forget to keep out twists when threading.

BATH MATS WITH A DIFFERENCE. (contd.,)

On completion of this operation replace the back bar and then carefully take each set of eight ends and staple them round the tie-bar on the back roller. When this is done, carefully wind on the warp removing any tangles with the fingers or a fairly coarse comb.

Now tension at the front of the loom in the normal way, beginning in the centre and working outwards and staple in eights round the tie-bar on the cloth roller at the front of the loom.

Proceed to weave in the normal way, but as no binder thread is used, do not select a shaft lifting pattern calling for more than one pick at a time. I usually use the sequence 3 & 4, 1 & 4, 1 & 2, 1 & 4 repeat, or a twill which is 1 & 2, 2 & 3, 3 & 4, 4 & 1 repeat. When the mat is the required length, leave enough for a small fringe by inserting a warp lath or roll of paper wider than the weaving. Now weave the second mat and cut off the loom. It is possible to make a knotted fringe or run a row of machining along the warp ends to secure them.

Materials required using 7 e.p.i. will be 1.1b of Plastic Tape and either two $\frac{1}{2}$ lb rolls for the weft of another colour, or 1 each of two colours. Remember to beat evenly and well to obtain a good mat and I am sure you will be very pleased with the results.

MAKE YOUR OWN CHRISTMAS CARDS.

If you have a flair for cut-out paper work you can amalgamate it with a little weaving and produce your own Greetings Cards.

Maybe you are like me and cannot cut paper patterns so, therefore, get a wood-working friend to cut some ply-wood or lino templates in the Seasonal emblems of Christmas trees etc., Then put a piece of coloured paper or thin cardboard on a metal or hardwood surface and cut round the template with a sharp knife or razor blade.

Now weave a strip of material suitable to stick behind the cut away portion; this should have some sparkle to add gaiety to the cards. Suitable greetings on the front and inside will look good in coloured inks.

A Green or Red warp of 12/2's with a simple pattern which could be carried out in white spiral gimp and a binder of rayon and lurex would look charming and inexpensive.

I am sure you will enjoy making these and your friends appreciate them much more than those "ready-made" from the stationer.

KNEE RUGS FOR THE CAR.

When we were packing up the yarns for removal to Castle Street, it occurred to me that we should offer you a chance to use up the odd knitting wools you may have together with some of the inexpensive Fibro we can offer.

Look over your wools and sort out Double Knitting from 3 and 4 ply. Use a fairly coarse reed, 9 or 10 dent per inch, and sley the Double Knitting singly and the 3 or 4 ply double - and treat them as one warp end.

Lay your warp according to your loom width, allowing anything up to $\frac{3}{4}$ yard extra for wastage and tie on. Usually a 32" width needs a woven length of 48" - 54", so for one you would need to warp 7ft full, as each end would take a 6" fringe. If more than one is needed, add finished length to 7ft for each one.

Plain setting with twill lifts should need $\frac{3}{4}$ lb of Fibro Mixture for the weft of each knee rug.

When weaving is finished, make knotted fringes and then wash to thicken and remove any surplus grease. Soft soap in the water is ideal, finishing with a rinsing water with ammonia. Wring well and if possible iron dry. You can tease up with a teazle brush if you wish.

SPECIAL CHRISTMAS OFFER.

We thought that with the Christmas gift time so close upon us, it might be of interest to our many customers to take this opportunity to avail themselves of some yarns at greatly reduced prices. So, here you are. All are in good condition and in most cases, not even soiled by dust during storage.

8/2's Plain Unbleached Warp Cotton. 4lb cones at £1 each - normally 8/- lb. Ideal for weft in towels, curtains etc.,

Tweed Fibro. $\frac{1}{2}$ lb hanks at 6/- lb, but if you can take 2lbs or more, then the price is 5/- per pound. Three colours have a proportion of white with them - they are Red, Navy, Light Blue. Two colours have black instead of the white - they are Red and Lime. Used across a knitting wool (as articulated at the top of this page) or tweed warp, they are delightful for knee rug wefts.

Chenille. Usually in 8oz hanks, now being cleared at 5/- per pound. A shaggy texture in Beige, Rose, Maroon and Off-White. Close texture in Fawn and Mole Grey. Makes a wonderful weft for cosey chair backs and cushions.

Spot Gimp. This is very useful for a binder thread and gives a slight texture. In Off-White only and 1.1b cheeses, we can offer this at 5/- per pound. Strongly recommended as a "must" for the store cupboard.

Please add usual packing and postage rates to the above yarns.

??? DO YOU KNOW THAT ???

.... E.P.I. means the number of warp ends to the inch when calculating the width and the yarn needed you are proposing to weave?

.... the figures vis 14/1 means the number of dents (or slots) to the inch on a reed?

.... double sley means that when you are threading the reed it is 2 ends in each dent? For instance, a 14/1 reed is doubled sleyed to give 28 e.p.i.

.... when you wind a warp on the warping posts, warping frame or mill, you are "laying a warp"?

"The Loom of Time."

Man's life is laid in the Loom of Time,
To a pattern he does not see:
While the Weaver works, and the shuttles fly
Till the doom of Eternity.
Some shuttles are filled with silver thread
And some with threads of gold:
While often but the darker hue
Is all that they may hold.
But the Weaver watches with skilful eye
Each shuttle fly to and fro,
And sees the pattern so deftly wrought
As the Loom moves sure and slow.
God surely planned that pattern,
Each thread - the dark and fair -
Was chosen by His master-skill
And placed in the web with care.
He - only - knows its beauty
And guides the shuttles which hold
The threads so unattractive
As well as the threads of gold.
Not till the Loom is silent,
And the shuttles cease to fly,
Shall God unroll the pattern
And explain the reason why -
The dark threads are as needful
In the Weaver's skilful hand,
As the threads of gold and silver
In the pattern He had planned.

This little poem was sent to us by one of the first students we had in the new premises. Mr. Wedgwood actually came to keep his wife company but went away completely convinced that weaving is the craft he is going to take up most seriously!

SALES AND WANTS.

- FOR SALE. 32" CANTERBURY Loom. £17.10.0.
Apply:- Mrs.Freeman, 32 Douglas Road, Herne Bay.
- FOR SALE. AUTOSHED. 270 bars, springs, hooks etc., and instructions.
45/- carriage paid. Apply:- Turnbull, 117 Gracefield Gardens,
London S.W.16.
- FOR SALE. 2 new 31" 28 and 32 dent reeds.
1 good 57" 26 dent reed - could be cut. £1 each.
Apply:- Box No.92. c/o "LOOMCRAFT", 57 Castle St., Canterbury.
- FOR SALE. 36" DOUGLAS ANDREW Table Loom. 4 shafts. Perfect condition
with equipment. £8 or near offer.
Apply:- Spencer, 22 The Avenue, Ersham Park, Hailsham, Sussex.
- FOR SALE. 30" COTTAGE type Loom, foot operated. Good condition, some
accessories. Reasonable offer accepted.
Apply:- 120, Clarke Road, Tankerton, Kent.
- FOR SALE. 32" WEAVERMASTER Table Loom complete with bobbin winder and
accessories. £5. Apply:- Mrs.Hollings, 'Patrew', Pine Walk,
East Horsley, Leatherhead, Surrey.
- FOR SALE. WARPING MILL with heck block and spreader. Will lay 50 yards
warp. Folds flat. £10.10.0 or near offer.
Apply:- Miss Snow, 23b Ethelbert Road, Canterbury.

SURPLUS STOCK - ALL IN EXCELLENT CONDITION.

- FOR SALE. 44" KENTISH LOOM 4 shaft 6 pedal Fly Shuttle Batten ... £25.
FLOOR RICE ... £2.10.0.
FULL SIZE SPOOL RACK ... £2.0.0.
EASY MASTER 2 shaft 12" Table Loom. Wire healds. ... £2.10.0.
EASY WEAVE 12" Rigid Heddle ... 30/-
DRYAD 4 shaft 9" Table Loom ... £3.0.0.

Above prices include carriage.

LOOMCRAFT

Single copy 1/3d. post free.

5/- per year inc.post.

BY WEAVERS—FOR WEAVERS—ABOUT WEAVERS

Volume Three.

JANUARY 1963

Number 4



Editorial.
Chintz Yarns.
Heat-resisting
Table Mats.
An Old Friend
Visited.
Advanced Pattern
Sun, Moon & Stars.
Tweed with Sample.
Huckaback Towels.
Special Offer for
Handwoven Tapes.
Tablet Weaving.
New Yarns.
Sales and Wants.

"LOOMCRAFT" is issued
Jan. April, July & Oct.

57, CASTLE STREET, CANTERBURY, KENT.

57, Castle Street,
Canterbury, Kent.

January 1963.

Dear Weavers,

What a wonderful array of cards and good wishes we received from you during December! We would all like to thank you very much and wish we had the time to reply individually to you, but it is not possible, even at this slightly quieter time of the year. So, please do understand we appreciate your thoughts and hope that 1963 will be a good year for you all.

As usual we have had our ear to the ground for attractive Special Offer yarns and we think you will agree that we have found some very useful numbers. Samples are available where needed, we only ask you to send a 3d. stamp for postage.

We hope that readers in this district at any time will find time to call and see us in our new premises. Now is the time to begin making arrangements for early or late vacations with which to enjoy the Kent Coast, and take a fifteen hour course of tuition for handweaving. This can be taken straight off in three days, giving you the evenings free, or we can arrange for you to study in the mornings only, and so give you the remainder of the day free to visit the many interesting and relaxing spots around the district. Why not think seriously about it and then drop us a line for further details?

With this issue we are giving you the first of four Tweed patterns with woven samples, we hope that you will like it. We aim at unusual drafts and also something to give you a starting point at which to begin your own designing.

So, here's to a good weaving year for all of us! We shall be happy to help you if we can, and if we do not have yarns in stock that you need, we shall try to obtain them for you, and you may rest assured that we shall be most competitive with prices.

With kind regards,

Sincerely yours,

Margaret A. Norris

(Mrs.) Margaret A. Norris.

MULTI-COLOURED CHINTZ YARN.

We bought a consignment of delightfully coloured cotton yarn with a slub appearance which introduces all the bright colours possible.

This has arrived in time to offer in "LOOMCRAFT", and after a conference between ourselves about suitable warps and settings, we think you, like us, will want to try it out.

As it is so pretty and colourful, it does not require a pattern threading, so 2 shaft weaving can come into its own once more! We decided that a fine, close warp was best. As there are two colour combinations in our delivery we will call them Light and Dark. For the Light one we found that a Royal Blue, Deep Yellow, Scarlet or Maroon made the best warp contrasts. For the Dark coloured yarn it was surprising to find that light warps did not seem to be the answer, but that Navy Blue 16/2's or Black 12/2's proved the best.

So, at a setting of 28 e.p.i. (double sleyed in a 14 dent reed), lay a warp for the width and length required. Let us suppose you decide to make two cushion covers 20 inches square. You will need a warp of 580 ends, 3 yards long. This will give you a little wider warp than 20" to allow for the slight drawing in which may occur. Plain threading through the healds, single throughout and double sleyed in a 14 dent reed.

After the tension is correct and all ties are made, weave a small heading of 1" with the same material as your warp. Now, still in plain weaving, use the Chintz Yarn for 40" full and finish off with a 2" strip of weaving in the cotton as warp. Make a cuttingline of two picks with a contrast and weave the second cover in the same way.

When you have taken this off the loom, divide at the cutting line and turn in the 1" strip, double it back on itself to form a "lip" of plain coloured weave. This takes the press studs if you wish for them, or tucks in, should you decide to slip-stitch the cushion pad in. Oversee the sides on the inside and your cushion covers are ready.

The total cost is 15/9d., for $\frac{1}{2}$ lb of 12/2's mercerised cotton and 1 lb of Chintz Yarn.

WARP COTTONS.

We find that plain unbleached warp cottons are rather difficult to obtain at the usual low prices. So, as many of our customers prefer smaller cheeses, we shall only offer the W.W. yarns at 9/- per pound on the $\frac{1}{4}$ lb. cheeses. This applies to 6/2's, 12/3's, 4/4's, 7/7's and eventually 20/2's.

HEAT RESISTING TABLE MATS.

How often does it happen that when a nice little table mat is set out with another mat beneath it to stop the heat from marking the polished table, the two mats decide to part company and so spoil the effect of a carefully planned table?

When you have a polished table, it is not unusual to spread a large white linen cloth with a thick cloth beneath it to protect the polish. In these days of laundry bills, it is nice to be able to wash table-mats by hand, so here we suggest an easy way to overcome the heat problem. This can only be achieved on a four shaft loom, and this is how you should dress your loom for it.

Let us suppose that you would like to have a reversible mat, in which case you will lay a warp giving 28 e.p.i. employing two colours used alternately. I would suggest 12/2's mercerised cotton for this and allow enough for three inches of plain weave at either side with the 12/2's.

Make the warp 10" wide, that is 280 ends, and if you are proposing to weave six place mats and one twice as long for the centre of the table, your warp should be at least three yards long. For this and the weft ends allow $\frac{1}{4}$ lb each of the two colours. The warp is plain threading throughout, single through the healds and double sleyed through a 14 dent reed.

Now weave 3 inches of plain weaving, using the two colours alternately. You will find that according to the way you throw the colours in conjunction with the shaft lifting, so you can alter the salt and pepper effect, but do remember which way you use for repeating at the other end! For the square in the middle of each place mat you must weave in double weave to give an opening at one side. For this weft I suggest two colours of 6/2's Mercerised Cotton (I estimate $\frac{1}{2}$ lb. each) and arrange the lifts so that one side is one colour and the other side the second colour. To obtain this, use the following lifts:-

Shafts.

1. 2. 4.)	once each
2. 3. 4.)	repeat for
2.)	length
4.)	required.

Use first one colour for 2 picks and then the second colour for the next two picks; in this way you will get an opening at one side. Be careful to see that the threads are even at the closed side and do not pull in more than you can help. Weave enough in this way to give a square, but allow for the slight contraction of the warp when off tension. Now repeat the 3" of plain weave to complete the mats.

Continued opposite

HEAT RESISTING MATS (contd.,)

I would suggest a small fringed edge, in which case leave enough for two and begin the second mat.

When all six have been woven, make a centre piece in the same way, except that the double weave is twice as long but the plain weave at either end is 3" as for the place mats.

When off the loom finish the fringes, buy some foam rubber underlay and cut squares to fit tightly in the double weave - roughly one square yard will be required for the set. You then slip-stitch the opening and the heat resisting mats are ready for use. The plain weave ends give space for the cutlery. When necessary to launder, you can wash gently with the foam rubber in place, or, it is quite easy to undo the slipstitching and remove if you would prefer to do so.

I hope you like this idea of two colours - it does allow for variation.

AN OLD FRIEND VISITED.

At the end of November we travelled to Cowes, Isle of Wight, to deliver an Altar Frontal which we had promised to the Vicar of St.Mary's. This was made of Pure Silk with the pattern "Golden Cross" carried out in Rayon Crepe Twist, and multi-coloured braids joining the panels. This was one of the last pieces of weaving by my Mother who died in September, and as she was so fond of Mr.Cumpsty, we thought it a most fitting place to be.

Whilst we were there we were delighted to see a fine dressing-stool top which Mr.Cumpsty wove during one of his visits for tuition, now mounted and in constant use. Also, a large easy-chair newly upholstered in another piece of handweaving by the Vicar was duly 'unveiled'. A second version of this was still due to come back from the work-room. Although Mr.Cumpsty is a very busy man, he manages to squeeze a little weaving in, sometimes as late as 11 o'clock in the evening!

When we were there he was just about to start a run of "Stars" given in "LOOMCRAFT" for July 1962. Now we understand this has been completed and a request for another pattern in "Crackle Weave" is being dealt with and we hope to give it in a number fairly soon.

A most delightful day and a pleasant half-an-hour inspecting the Rabbit Family which is Mrs.Cumpsty's joy! For anyone with similar tastes, they are Bevrens. Incidentally, Mr.Cumpsty may be remembered by our early readers under the non-de-plume of "Rosepath 'Arry" - he has progressed since then!!

ADVANCED PATTERN - "SUN, MOON & STARS" MODIFICATION.

In the very early days of "LOOMCRAFT" a longer version of this old Colonial pattern was given, mainly to help so many weavers who called to see us, and liked a padded stool top I have.

Now I think a smaller draft of 90 warp ends will be useful for many things so I have worked it out to use for chair backs, shoulder cushions for the car or a high-backed chair, or even ends of table runners and casement curtains.

The warp setting is 28 e.p.i. (double sleyed through a 14 dent reed) and single threading of all healds. To give a width of 18" on the loom, lay a warp of 447 ends with 12/2's cotton. The first 44 ends are in twill, then 4 complete patterns, 90 ends each, finishing with 43 in twill at the other side. A breakdown and full threading instructions are given on the loose sheet herewith, also the shaft lifting, although it is "as drawn in".

For the pattern weft I suggest 6/2's Mercerised or Lyscordet. A fairly thin Candlewick will also do but always try a few picks first to be sure it suits the warp and binder thread. Where the pattern is woven continuously, a rough estimate is 4 oz of 12/2's cotton at this setting and width for the warp and binder thread. For the pattern allow $\frac{1}{4}$ lb. of 6/2's cotton or 5 to 6 ounces of Lyscordet per yard run.

A good idea is to use a natural coloured warp and vary the binder thread if you are making several articles, using either 12/2's cotton or machine Sylko. This will make most interesting weaving and give rise to new ideas, I hope!

BONUS VOUCHERS.

We shall continue to give Bonus Vouchers for purchases over 5/- but would once more point out that these are not exchangeable if under 2/6d., worth at a time. Also, please do not send them in to pay off odd amounts. We can only accept them with a new order; in this way we can adjust our invoice to allow for them, but not our Cash Book. I am sorry that it has been necessary to mention this again, but it is very awkward when these simple conditions are not adhered to. Thank you.

"NIDDY-NODDY".

A device in the shape of a wooden sword, used for skeining spun wool. Enables the weaver to wind a long skein with a relatively small implement.

THREADING DRAFT FOR SUN, MOON & STARS. ADVANCED PATTERN FOR JANUARY 1963.

Please note that owing to a printers' error, the width on the loom should read 16" for 447 ends. If you need 18" width add a further 56 ends when laying the warp, and thread the twill borders 18 and 17 times instead of the 11 and 10 as shown here.

4	4	4	4	4 4 4 4	4 4	4 4 4	4	4
3 3 3	3 3 3	3 3 3	3 3 3	3 3 3 3 3 3 3 3		3 3 3	3	3
2 2	2 2	2 2	2 2	2 2	2 2	2 2 2	2	2
				1 1 1 1 1 1 1 1 1 1		1	1	1
.....Pattern. Thread 4 times.....							Selv.	Shafts.
							(11 times)	
<u>Warp split.</u>		4	4	4 4 4	4 4	4 4 4 4		
Selv.	44	3	3	3 3 3			3 3	
4 Patterns	360	2	2	2 2	2 2	2 2		
Link bal.	3	1		1	1 1 1 1 1 1 1 1 1 1			
Selv.	40	Selv.	Bal.				
	447 ends.	(10 times)						

Weaving lifts. For pedal looms it is a standard tie-up. A BINDER ROW AFTER EVERY PATTERN ROW.

<u>Shafts.</u>	<u>Pedals.</u>	<u>Times.</u>		<u>shafts.</u>	<u>Pedals.</u>	<u>Times.</u>
1-2	1	1) Twill Border.	3-4	5	2
2-3	2	1) Repeat as	2-3	2	4
3-4	5	1) desired.	3-4	5	2
4-1	6	1)	2-3	2	4
1-2	1	4	∅	3-4	5	6
2-3	2	4		4-1	6	4
3-4	5	4		2-1	1	4
4-1	6	4		4-1	6	4
1-2	1	4		2-1	1	4
4-1	6	4		4-1	6	4
3-4	5	6		2-1	1	4
2-3	2	4		4-1	6	4
3-4	5	2		3-4	5	4
2-3	2	4		2-3	2	4
3-4	5	2				
2-3	2	4	4..contd			

If pattern is to be repeated throughout commence again at ∅, but if it is for a border only, then repeat the first lift marked, ∅, and complete the pattern by weaving the Twill border in reverse to match the beginning.

TWEED WITH SAMPLE.

The attractive thing about being a Handweaver is the variety and scope the Craft offers to anyone prepared to experiment whilst weaving. This we try to foster with our numerous articles in "LOOMCRAFT", but we on the other hand always welcome the handweaver who tells us that by variation of some instructions given, a completely new result has been evolved.



In the same way we are always pleased when a customer comes to the Showroom and says - "Can you weave a piece of tweed for me that is different from the usual run of checks and stripes which can be obtained so easily?"

This is to us a challenge, and we only stipulate that we are given time to analyse the sample with which we are confronted. The "Beauchamp Twill" came from such a commission, but it also had some strange colour combinations.

The sample is of a $4\frac{1}{2}$ cut knop yarn, and two colours of a fine Scottish Tweed such as we are bringing into our stocks to replace the 20 cut Cuthil which the makers are withdrawing.

A 9 dent reed was used, but if you do not have the size, an 8 dent will give you a slightly more open cloth and a 10 dent reed a little closer. You must also remember to adjust your beat accordingly if you wish to "square" the weave. The warp was:-

1 Red, 1 Green, 1 Brown, 1 Green, 1 Red, 1 Brown repeated for the width required.

The warp was threaded single through the healds throughout. The reed was sleyed with 2 fine tweed ends in one dent, but the Brown Knop yarn was sleyed singly. The threading was for plain weave and the shaft lifts were plain weave also.

Use a plain colour such as Black or Brown for the $4\frac{1}{2}$ cut Knop Yarn and bring colour into the weaving by way of the fine tweed yarns used with it. We have both brown and black knop yarns in stock and you will need $\frac{1}{2}$ lb. of this per yard length by 32" weaving width, which of course with scouring and finishing will bring it down to 27" - 28" width. Of the fine tweed yarn allow $\frac{3}{4}$ ounces per yard, split between the colours used.

We shall be happy to carry out the finishing process for you. This service is primarily for our customers and the charge is 1/9d., per yard or part of a yard, plus the return postage. Please allow 14 days for the return of your material.

HUCKABACK TOWELS.

Have you tried guest towels for your bathroom or cloakroom in Huckaback? They look very gay and attractive if carried out in a colour scheme to suit your surroundings.

I would propose a 12/2's mercerised cotton warp in colour, sett at 28 e.p.i. and then, except for the hems the towels themselves are woven with a fine white linen for weft. This is how I suggest to begin.

A $\frac{1}{4}$ lb tube of coloured 12/2's mercerised cotton will give you enough for a $2\frac{1}{4}$ yard warp of 372 ends and the weft for 2" of plain weave at each end of three towels. For the rest of the towels use a white or whitey brown linen of 25/2's allowing $\frac{1}{4}$ lb. for this length of warp. In this way the colour of the warp will be thrown in relief.

Use a 14 dent reed, double sleyed but single through the healds. After laying the warp thread and sley it into the loom as follows:-

Threading Draft.

4 4 3 3 2 1	4 4 3 3 3 2 2 2 1 1	4 3 2 2 1 1	4 3 2 1
<u>Selvedge.</u> (6 ends)	<u>Pattern</u> 10 ends. repeat 36 times.	<u>Selvedge.</u> (6 ends)	<u>Shafts.</u>

This will give you $12\frac{1}{2}$ " width through the reed. For pedal looms the tie-up is:-

<u>Shafts.</u>	<u>Pedals.</u>	
2	2)	
1 - 3	3)	
2 - 4	4)	Plain weave.
3	5)	

Counting from the RIGHT. This leaves the two outer pedals at each end not in use. Memorise these tie-ups or make a note of them on the Castle-head as the weaving lifts will be given in shaft numbers for the benefit of table-loom weavers.

Weaving Lifts. Work for 2 inches at the beginning and end of each towel in plain weave with 12/2's mercerised cotton as used for the warp. This will give a 1" hem which can either be machined in place, or 2 or 3 warp threads drawn out and hemstitched.

Continued opposite

HUCKABACK TOWELS (contd.,)

Now for 17" weave with linen as follows repeating throughout:-

<u>Shafts.</u>	<u>Times.</u>
1 - 3	1
2	1
1 - 3	1
2	1
1 - 3	1
2 - 4	1
3	1
2 - 4	1
3	1
2 - 4	1

I find that it is a good idea to throw a couple of picks at the end of each towel before commencing the second towel, this is a guide as to where to cut when making up.

Although I have suggested the greater part of the warp for each towel should be in linen, should you have a supply of contrasting cotton in hand, use this in the same way, but with the setting given do not use anything thicker than 12/3's, as it would make the material too thick for its purpose.

I would suggest that you soak the made-up towels in rain water for 24 hours, if available, and then hang up to drip-dry. Now launder in the usual way.

Providing you do not waste too much with the tie-on, it should be possible to make three towels on this warp, which will be 20" x 12" approx. for 14/6d., We have some White Linen on the Special Offer List (S.O.40) at 4/- per ¼ lb. cheese - this would bring your towels down to 9/- for three. I would like to mention that once this is cleared we cannot repeat.

PACKAGE AND POSTAGE. We find that quite a number of our postal friends are getting very forgetful in this direction. Once more I must remind you that by the time we have used wrapping and an outside paper, plus string etc., further weight is added to your requirements. Therefore, if you order 3 lbs. of yarns your parcel requires postage for 4 lbs. i.e. 2/6d., so please allow for this. Also, to give you door to door service it requires better packing than a paper bag as for cash and carry purchases. So, we do not feel we are being unreasonable to ask you to add 3d., more for packing material and labour involved. Please do try to see our point of view and co-operate. We do try to help!

Thank you.

LABELS FOR YOUR HANDWEAVING.

How often do you hear the remark, "Is it HANDwoven?" Perhaps the enquirer would have found much pleasure in the workmanship if a small label had been attached saying, "HANDWOVEN".

To buy the tabs giving your name as well as the word HANDWOVEN, is now becoming rather expensive, but of course some of our customers still like to have them and we are always happy to receive orders. This normally takes 14/21 days for delivery except in Mid-Summer when it can take six weeks. This is due to so many children going to schools where all clothing must be marked. However, if you do decide that 7/6d., for 3 dozen is within your budget, you should choose the colour and type of lettering you would like, bearing in mind that the tape is always white, and after allowing for the standard words, "Handwoven by ...", you can stipulate up to 11 letters more. One gross of tabs (for the very busy weaver) costs 13/9d., Do not hesitate to consult us if you need advice.

The plainer tabs in Beige satin with the word "HANDWOVEN" stamped on is well within the handweaver's budget and I advise a supply of these to all of you. Up to now we have bought these for resale at 1/6d., per dozen, but buying in bulk gives us the chance to offer them at 3/6d., for 3 dozen, post free. I do hope that you will take advantage of this offer and request us to include 3 dozen with your next order. For quantities less than 3 dozen, the price must remain 1/6d., per dozen, plus postage.

CHRISTMAS CARDS FROM THE OCTOBER NUMBER.

I think that quite a number of handwoven handmade cards were sent to people with unusual tastes, and I hope they all enjoyed them as much as I enjoyed one I received on Christmas Eve. It came from the Girls of Welling Secondary School, Berwick Road, Welling, and was a fine Christmas Tree with the shape and plant pot cut out of the front page. Behind this aperture was a piece of weaving which gave a red plant pot and a beautiful glistening tree of red and green woven with Lurex on a plain cotton warp. Inside this card was just the word, "Greetings", and then the message from the girls at the bottom saying, "Woven on a "Palace" Loom". We were very interested to see this card in our mail and I had the added thrill to think it was the fruits of a suggestion given in "LOOMCRAFT".

TABLET WEAVING.

A method used for making narrow fabric or braid. The 'loom' consists of thin, smooth squares measuring $\frac{2}{3}$ inches made of wood, bone or composition which act as heddles, and two metal or wooden uprights fitted with clamps which carry the warp threads. The tablets have holes punched into each rounded corner numbered 1 & 2, and 3 & 4. One warp thread is taken through each hole. A small flat shuttle with a smooth, thin edge carries the weft and is used as a beater. The shed is made by turning the tablets a quarter-turn to the right or left.

NEW YARNS ON THE SPECIAL OFFER LIST.

FINE EGYPTIAN MERCERISED COTTONS.

For some time we have been able to offer you 16/2's Egyptian Mercerised Cotton on $\frac{1}{2}$.lb cheeses at 20/- per pound. Now we have been fortunate enough to find some more colours in a slightly thicker count - 12/2's and 14/2's, which enables us to make quite a good range of fine cottons for the handweaver needing Egyptian cottons in colour. The only one of 14/2's count is a soft yellow-green; the rest of our new additions are 12/2's in Salmon, Pink, Maroon, Orange, Deep Purple, Dark Green and Light Royal. These, together with our existing range of 16/2's in Black, White, Pale Gold, Scarlet, Navy and Helio will in future be offered together as "Fine Egyptian Mercerised Cottons", and known also as S.O.13 at 10/- per $\frac{1}{2}$.lb cheese. I am assured they are fast dyes.

MULTI-COLOURED CHINTZ YARNS.

We have already introduced you to this by way of an article on Page 3 of this issue. It only remains for me to suggest that gay aprons, casement curtains, and if you have time, even a bedspread! In the Spring a cotton skirt would look good in this yarn with an appropriate warp. A 1.lb cone will go a long way.

THICK WEAVING COTTONS.

Some two years ago we obtained a quantity of thick coloured cottons which some folk term as "Candlewick". I think the Candlewick which was on offer in most needlework shops, but now discontinued by the Makers, appeared to be thicker, in fact, it only yielded 24 yards per ounce, so I refrain from giving our newest purchase that title. The thick weaving cotton we can now supply is in Green, Salmon, Wine, Gold, Royal and Scarlet. We also have some 4/4's Weaving Cotton in Pale Blue, Pale Green and Pink. These are all listed together with a small quantity of Lilac and Mauve, at 8/- per pound.

MEDIUM COUNT MERCERISED COTTON.

Three colours only in this offer. A good beige very handy for warps etc., a Rust which is most useful and a Deep Orange to brighten up any weaving. It is very similar to Lyscordet and at a quick guess I would say it is 4/2's count. Now that so many strong colours on the Lyscordet range have disappeared, these yarns will be very welcome for chair seats and fairly heavy fabrics. The price is right - 12/- per pound, and the pack is $\frac{1}{4}$.lb. hanks. We bought all there was of this yarn on offer so please order enough for your project to avoid disappointment.

OFF-WHITE RAYON GIMP.

We offered this last year but did not enlarge on it. Now you may be looking for something to add to the weft of your curtains due to be put up after Spring-cleaning. This yarn dyes quite well, so you need not fear that it is an off-white only line. It comes in hanks of $2\frac{1}{2}$ ounces approximately and they cost 1/3d., each. We heard of one weaver who found it most attractive in table mats but we do not quite know how she used it. We have suggested to her that she may like to let us have an article giving her method, so watch our pages.

SALES AND WANTS.

FOR SALE. "KENTISH" FOOT LOOM. 4 shafts 44" width. 16 dent reed. Cord healds. Warping pegs and skeiners. All accessories etc., Well preserved. Only reason for sale is need of space. £40 O.N.O.
Box No.93. c/o "LOOMCRAFT" 57, Castle Street, Canterbury.

FOR SALE. "CHILTERN" FOOT LOOM 38" width. 4 shafts, 14 dent reed, shuttles etc., cord healds. Excellent condition. Weaver reverting to narrower model, same make. £35 O.N.O.
Apply:- Box No.94 c/o "LOOMCRAFT", 57, Castle St, Canterbury.

FOR SALE. "EASIMASTER" 12" 2 shaft. Wire healds, shuttles etc., £2 incl.carriage. Apply, Cathedral Weaving Centre, Canterbury.

WANTED. DOUGLAS ANDREW "GUILD" LOOM. Send all particulars - age, use & accessories to Box No.95 c/o. "LOOMCRAFT", 57 Castle Street, Canterbury. Must be in good condition.

SECOND HAND REEDS FOR SALE.

9"	length.	12	dents	per	inch.	6/6d.	including	post.
11"	"	24	"	"	"	7/6d.	"	"
11"	"	10	"	"	"	6/6d.	"	"
12"	"	3	"	"	"	5/6d.	"	"
12"	"	20	"	"	"	7/6d.	"	"
14 $\frac{1}{2}$ "	"	20	"	"	"	8/-	"	"
32"	"	14	"	"	"	17/6d.	"	"
33"	"	5	"	"	"	17/6d.	"	"
36"	"	20	"	"	"	17/6d.	"	"
37 $\frac{1}{2}$ "	"	10	"	"	"	18/6d.	"	"
38"	"	14	"	"	"	18/6d.	"	"
38"	"	16	"	"	"	18/6d.	"	"
42"	"	14	"	"	"	21/-	"	"
43"	"	12	"	"	"	21/-	"	"

With our several School Scarves contracts, we have been trying out various wools for durability and economy. It is now proved that the Crossbred wool fills the bill in these respects. Therefore, we have now laid in a stock of colours and plys for your benefit. All colours can be supplied in 3 ply, 4 ply and Double Knitting, and is put up in balls. For a scarf 11" wide and 52" long, you will need 5 oz. of 3 ply and at 1/4d., per ounce this makes the cost 6/8d., If you weave two or more at a time, then I would add 4 oz. per extra scarf.

LOOMCRAFT

Single copy 1/3d., post free.

5/- per year inc.post.

BY WEAVERS—FOR WEAVERS—ABOUT WEAVERS

Volume Three

APRIL 1963

Number 5.



Editorial.
Trolley Cloths.
Folk Weave.
Folk Weave
Patterns.
Crackle Weave.
Tweed with Sample.
Upholstery Material.
Candid Comments.
Yarns.
Books.
Sales & Wants.

"LOOMCRAFT" is issued
Jan. April, July & Oct.

57, CASTLE STREET, CANTERBURY, KENT.

Tele. Canterbury 3935.

57, Castle Street,
CANTERBURY.
Kent.

April 1963.

Dear Fellow Weavers,

First of all may I say how much we all appreciate the very nice things you said about the January issue of "LOOMCRAFT". It is so interesting to learn how various articles appeal to different weavers. We try to make each number as varied as we can and it often happens that we plan the lay-out and then something comes along and we take one thing out and put another article in until we have altered it completely!

So many of you write chatty little notes with your orders and we are always happy to receive them, but please do not think we are unkind if we cannot send you an acknowledgement. We wish we could, but it is pretty busy here most of the time and we feel that early delivery of your orders should be our first concern.

We have just heard that at the end of April some of the Parcel Post charges are going up again. Will you please bear this in mind and help us to help you? We realise that this is something of a hardship to some folks, but we try to keep our prices at rock bottom and we cannot undertake to pay postage.

Do call and see us if you are this way at any time, we thrive on friendship.

Sincerely yours,

MARGARET A. NORRIS (MRS.,)

TROLLEY CLOTHS IN TWO COLOURS.

I saw a delightful set of coffee cups the other day placed on trolley cloths to match. I thought it looked extremely effective and I decided that I would pass the idea on to you with instructions for handweaving them. So, here you are!

Either in 25/2's Linen or 12/2's Cotton, both sett at 28 e.p.i. in plain weave, but the warp in the trolley cloth I saw was 1 end Off-white and 1 end Deep Blue. A fair sized cloth will need an 18 inch warp so, lay a warp of 500 ends, 3 yards long for two trolley cloths (16" x 24").

The weaving was also plain weave and after some waste cotton has sett the warp (this can be unravelled to give the $\frac{1}{2}$ " fringe when making up) proceed in stripes on lines something like this:-

1"	Off-white.
$\frac{1}{2}$ "	alternate Blue & White.
1"	Off-white.
1"	alternate Blue & White.
17"	Blue
1"	alternate Blue & White.
1"	Off-white.
$\frac{1}{2}$ "	alternate Blue & White.
1"	Off-white.

Remember to leave a couple of inches after a few rows of waste to hold the first cloth and before you begin the second one. When both are completed, remove from the loom and either machine all round or hemstitch $\frac{1}{2}$ " in, and then fringe to give finish. Launder in the usual way and they are ready for use.

I estimate you will need $\frac{1}{4}$.lb. of Off-white and $\frac{1}{2}$.lb. of the Blue in 12/2's Mercerised Cotton, or should you prefer to try 25/2's Linen, then you will need 4oz of Off-white and 6oz of Blue.

LUREX ON HALF-POUND REELS.

We were offered a small amount of Lurex in Gold and Silver on $\frac{1}{2}$.lb. reels which we bought knowing that some of our readers are often needing this for stoles and lacey scarves etc., Our usual price is 2/6d., for a $\frac{1}{4}$.oz. pirn, but we are happy to offer these $\frac{1}{2}$.lb reels at 15/- each. Most of them are still in the original wrapping paper and all are in perfect condition.

Please do not leave it too long before ordering as we do not have an unlimited supply of this. One, or even two of these in your store cupboard will always be useful; it stores well and gives glitter to weaving when this effect is desired.

FOLK WEAVE CURTAINS.

Now that we have a good selection of thick weaving cottons, it is possible that some weavers may like to try some curtains on the Folk Weave lines. Apart from our old friend "Rosepath", there are several other simple drafts which lend themselves to this kind of thing. "Monks Belt" is quite good but inclined to be rather stiff and square. "Honeysuckle" however, is graceful and offers quite a variety of patterns which are pleasant by themselves or blend together to give attractive bands to any fabric. One thing I would say about the "Honeysuckle" threading is, that in view of the overshots, it is advisable not to sett it too open.

If a 12/2's Cotton is used for the warp and sett at 21 e.p.i. then for the plain weave of the curtains a 6/2's could be used to give body to the curtains. If, however, you wish the plain weave to be in 12/2's throughout, then the setting should be 28 ends per inch. In either case, a fourteen dent reed can be used either threading 2 & 1 alternately or double sleyed. I like to see a pattern nicely balanced so I am setting the pattern draft out to cover this.

Threading Draft.

4	4 4 4	4	4	4 4 4	4	4
3		3 3	3	3 3	3	3
2		2 2 2	2 2	2 2 2	2	2
1	1 1 1 1	1	1	1 1 1 1 1	1	1

<u>Selvedge</u>	<u>End Bal.</u>	<u>Pattern</u>	<u>Selvedge</u>	<u>Shafts.</u>
twice (8)	Once (7)		(26 threads)		twice (8)	

The selvedge is 8 threads either side and the pattern is 26 threads repeated for width, balancing off with the 7 threads after the last repeat.

A binder row follows every pattern row. If you are using 6/2's for the plain weave part of the curtain, I would suggest you still use 12/2's cotton for the binder rows or even finer. Perhaps you may decide to use a colour to harmonize with the overall effect for the binder, in which case a machine twist will do.

The lifts are for a table loom, but weavers with foot looms should use standard tie-up which will give the same lifts.

We have split the pattern lifts up into units and if you allow an extra $\frac{1}{2}$ yard of warp, try them all out first so that any that do not appeal to you can be omitted.

Weave about $\frac{1}{2}$ " of plain weave between the bands of pattern, we can supply the thick weaving cotton in hanks as small as $\frac{1}{4}$ lb. so you have plenty of opportunity to make your curtains very colourful.

You will find five suggested patterns laid out on Page 5 opposite.

FOLK WEAVE PATTERNS. (Continued from Page 4.)

Pattern No.1.

<u>Shafts.</u>	<u>Times.</u>	
4 - 1	1) Repeat 3 times.
1 - 2	1	
2 - 3	1	
3 - 4	1	
4 - 1	15	
3 - 4	1) Repeat 3 times.
2 - 3	1	
1 - 2	1	
4 - 1	1	

Pattern No.2.

<u>Shafts.</u>	<u>Times.</u>	
3 - 4	1) Repeat 3 times.
2 - 3	1	
1 - 2	1	
4 - 1	1	
4 - 1	10	
4 - 1	1) Repeat 3 times.
1 - 2	1	
2 - 3	1	
3 - 4	1	

Pattern No.3.

<u>Shafts.</u>	<u>Times.</u>
4 - 1	1
1 - 2	1
2 - 3	1
3 - 4	1
2 - 3	1
1 - 2	1
4 - 1	2
1 - 2	2
2 - 3	2
1 - 2	2
4 - 1	8
1 - 2	2
2 - 3	2
1 - 2	2
4 - 1	2
1 - 2	1
2 - 3	1
3 - 4	1
2 - 3	1
1 - 2	1
4 - 1	1

Pattern No.4.

<u>Shafts.</u>	<u>Times.</u>
4 - 1	1
1 - 2	1
2 - 3	1
3 - 4	1
2 - 3	1
1 - 2	1
4 - 1	1

Pattern No.5.

<u>Shafts.</u>	<u>Times.</u>
3 - 4	1
2 - 3	1
1 - 2	1
1 - 4	1
1 - 2	1
2 - 3	1
3 - 4	1

ABOUT "LOOMCRAFT". (So writes Mrs.M.Baldwin, of Ohio.) I have been looking for a Niddy-Noddy for twenty years. Antique dealers look at me with their mouths open when I enquire for one! However, I remember seeing about a hundred of them in a heap at the Henry Ford Museum in Greenfield Village - I felt like lifting up the guard rope and swiping one! They had so many they did not value them."

SMALL CRACKLE WEAVE PATTERN.

If you need an all over pattern to take lots of hard wear, then I think you will like this draft. It will make very good "backs" to cushions where only one side in heavy pattern is required, or a cushion for the car or garden with both sides in this weave.

Make it fairly fine so that the little squares look like flower petals with the odd touches of colour in the background - a notable feature in this weave, and incidentally, the reason for its name. Mrs. Atwater found the weave in old pattern books and when she tried them out they reminded her of old china which had become slightly cracked with age, hence the name "Crackle" weave.

Use 6/2's Mercerised Cotton or Lyscordet for the pattern work, but a fine cotton 12/2's or 16/2's for the warp and binder threads. I would suggest a 14 dent reed, double sleyed to give 28 e.p.i. Allow 1/2 lb. of 12/2's per square yard and about the same of 6/2's of Lyscordet for the pattern thread.

Threading Draft.

4	4	4	4	4	4	4
3 3	3 3 3	3 3 3 3 3	3 3	3		
2 2	2 2 2 2	2 2 2 2 2	2 2	2		
1 1	1 1	1 1	1 1	1 1		

<u>Selvedge (7)</u>	<u>End Balance</u>	<u>Pattern 14 ends..</u>	<u>Selvedge</u>	<u>Shafts.</u>
	<u>of Patt. (11)</u>	repeat.	(7)	

Repeat the 14 ends of the pattern as many times as necessary for your width, ending with the extra 11 threads to balance. You will notice that both selvedges take only 7 threads each, borrowing the first and last threads of the patterns to make the 8 in each case.

Pedal looms take the standard tie-up and a binder row of 12/2's (or the same as the warp) follows every pattern row. The weaving proceeds as follows:-

<u>Shafts.</u>	<u>Times.</u>	<u>Shafts.</u>	<u>Times.</u>
3 - 4	1	4 - 1	1
2 - 3	1	1 - 2	1
3 - 4	1	4 - 1	1
4 - 1	1	3 - 4	1
3 - 4	1	4 - 1	1
2 - 3	1	1 - 2	1
3 - 4	1	4 - 1	1
	1 contd.....		

Repeat
for
length
required.

It is a good idea to weave 1/2" at least in plain weave at the beginning and end of each length, this allows for small hems. I am sure you will find this a most effective little pattern and so useful too.

TWEED WITH SAMPLE.

The Brown, Red and Green Tweed that we gave you last January has proved very popular, but I do wish more folks had varied the colour scheme. We did tell you that besides the Brown $4\frac{1}{2}$ cut Knop Yarn, we had Black in stock but only a few customers were bold enough to order anything other than Brown!

If you are still thinking about it, do consider Black with say Red and Yellow or, we can supply a light Fawn, same cut, which would take two darker colours very well.

Incidentally, a little under 1 yard makes the front of a gentleman's waistcoat - we tried it and my husband is very pleased with the one he is now wearing!

This time we are giving you another tweed with a check design. This uses two weights again but not a knop yarn. The Green and Grey are medium weight Scottish Tweed yarns and the Yellow is again a fine Shetland tweed yarn.

A 14 dent reed was used but if you only have a 16 dent reed then use this and put on more warp threads to give you the 32" width on the loom. Should you have neither of the above sizes, but a 10 or 12 dent reed, then you must adjust the warp lay and when sleying the reed, thread it to give either 15 or 16 per inch, bearing in mind that the 2 Yellow threads are always treated as one i.e. threaded in the same dent.

You will need a warp of 368 ends of the Scottish Tweed and 180 ends of the Shetland Tweed. It should be laid as follows:-

6 ends of Colour 1 Scottish Tweed.
2 " " Fine Shetland Tweed.

Then

4 ends of Colour 2 Scottish Tweed
2 " " Fine Shetland Tweed
4 " " Colour 1 Scottish Tweed
2 " " Fine Shetland Tweed.

Continue in this order until you have 89 repeats and finish with 6 ends of Colour 1 of the Scottish Tweed. All ends are single through the healds but when sleying the reed, the Scottish Tweed is single and the Shetland Tweed is double, except the first two and last two dents of the width in the reed which are Scottish Tweed sleyed double, hence the 6 warp ends at the beginning and end of the warp lay.



UPHOLSTERY MATERIAL

Are you thinking of recovering a chair? Then you may be interested in this suggestion sent to us by one of our regular readers.

The warp was 12/2's Black Cotton sett at 28/1 and double sleyed through a 14 dent reed, single through the healds. The threading was plain weave - 1, 2, 3, 4 repeated throughout, but the weaving took on rather an interesting sequence as follows:-

<u>Shafts.</u>	<u>Times.</u>	
1 - 2	6)	
2 - 3	6)	Repeated
3 - 4	6)	throughout.
4 - 1	6)	

The above was in Black 12/2's Cotton but each pick was followed by a binder thread of fine spot gimp in White, using shafts, 1 - 3 & 2 - 4 alternately. A firm attractive texture was the result and I can see that it will produce a good fabric for upholstery. Why not try it in a colour scheme to suit your room?

Allow $\frac{1}{2}$ lb. of 12/2's cotton to the square yard plus 3 to 4 oz. of the spot gimp for binder. At 5/- per pound this spot gimp makes a fairly inexpensive material that will look good and wear well.

User of a "Chiltern" and "Palace" Loom says:-

"It's such fun working things out on the PUP (Palace). Blessings on your "Chiltern" Loom. Thank God for looms!"

This letter was received when we were covered in snow and ice and indoor activities were such a boon.

TWEED SAMPLE (Continued from Page 7)

The threading is as for plain weave - 1, 2, 3, 4 throughout. The weaving lifts are twill - 1 & 2, 2 & 3, 3 & 4 and 4 & 1 repeated for length and the yarn is used to correspond with the colouring of the warp.

Allow 7.oz of the Scottish Tweed and 3.oz of the Fine Shetland Tweed per yard length, remembering that the width will reduce to approximately 27" - 28" when finally scoured and finished ready for tailoring. We shall be happy to carry out the finishing process for you, the charge being 1/9d., per yard or part of a yard, plus the return postage. We would, however, like to point out that this service is primarily for our customers as we do not like to accept the responsibility for yarns not of our supply.

CANDID COMMENTS.

We should like to say how grateful we were to receive the many letters telling us how much you all appreciated the January "LOOMCRAFT". Although we try to make each number as good as the last, it does us a power of good to learn that our efforts have proved better than we hoped. Perhaps it was the extreme weather that made you enjoy the first number of a new year. Perhaps you were also looking for something to take your minds off the heating problem and maybe you were unfortunate enough to be house-bound and the arrival of a new "LOOMCRAFT" saved the day!

The "Huckaback" Guest Towels were very popular, and I have seen several runs woven by local weavers and have also had glowing reports from friends farther afield. Some folks reversed the order and warped with a White 12/2's cotton using up odd spools of linens in the store cupboard. An excellent idea and a means of using up the remains from earlier projects.

The Chintz Yarn also amused many weavers and now we have only a few pounds left. This is one of the "easy" yarns where I do not have to rack my brains to make suitable suggestions for its use!

This brings me to a point we would like to mention. Will you please make sure that any pattern threads you are sending with your orders are securely fastened to your letters etc., We open many letters in the course of a week and if the orders reach the Despatch Room before we discover that the samples are not there, then there is a frantic search through the envelopes, (already in the wastepaper basket, and sometimes in the dustbin!) This takes up valuable time and if not found, we must then write to you which delays your order for days.

Thank you for being so understanding about pack and post. This is a big headache with us and we do ask you all to think carefully before putting down a figure far below the actual cost. If you send too much we can always make up the odd coppers with a few HANDWOVEN tabs.

We heard an amusing tale of the rigours endured by one of our weaving friends whilst the snow and ice were with us and we think it is worth passing on to you:-

Our friend is an Hungarian refugee, now living in England for several years. The Refugee Authorities put him in charge of a house near here with the idea of being able to send folks to stay for a short spell when they need a holiday. To augment his expenses, our friend weaves Priests Vestments and he keeps his looms in an outhouse - the weather got colder and colder, and the fuel for the stove in the weaving shed got lower and lower with no hope of more for days. He looked around and after old tables and chairs had been burnt, he decided that an ancient piano must follow suit. We have heard of Nero fiddling whilst Rome burnt, but this new version of weaving whilst the music burnt strikes us as very amusing. Still, it cleared a lot of junk our friend says! I think we all experienced some discomfort this winter as Mrs. Houston, of At. Austell wrote:- "Your journal came as a bright spot in a dreary month of frozen water, burst pipes, power cuts and fuel shortage!!!"

YARN COUNTS.

Cotton yarn is always in demand and I am frequently receiving orders which just state, "Please send me enough to make a warp", then the request for the number of ends and length needed. So many weavers do not know how to estimate the amounts required. First of all let me say this, always bear in mind that in all cases the Golden Rule is:- "The higher the number, the finer the yarn".

Now, let us suppose you wish to make a warp using 12/2's cotton. The "12" is the count or number of hanks to the pound of yarn. A hank of cotton is 840 yards, so, 840×12 gives 10080. The "2" is the ply which means that 10080 yards has been twisted or spun into a 2 fold cotton, so we now divide 10080 by 2, giving a final yardage of 5020 to the pound.

Therefore, supposing the warp is to be 20 inches wide when finished, you should allow another inch in the width for slight wasting on the loom and at least $\frac{1}{2}$ yard for tie-up at back and front. Hence, $28 \times 21 = 588$ ends, $3\frac{1}{2}$ yards long means $588 \times 3\frac{1}{2}$ times giving 2058 yards in all. As you will, no doubt, need a little perhaps for binder threads or headings, I should estimate $\frac{1}{2}$.lb. would be required. If you are intending to weave in 12/2's as well, then it would take the same amount for a balanced fabric and you should manage on $\frac{3}{4}$.lb. which takes up the excess from the $\frac{1}{2}$.lb. purchased for the warp. Treat other yarns of cottons in the same way. I hope you can now see how we have to work these things out for you and the amount of time it involves. Every one seems to have a different project!!!

Linens work the same way except that a hank of linen is referred to as a "lea" and is 300 yards in length, otherwise the working out is the same.

Tweed wools are slightly more complicated but I will tell you how I find it easiest to estimate for this type of weaving. Tweed yarn is known by "cuts" and is, of course, singles as no plying is done. A "cut" is 300 yards, but is worked on $1\frac{1}{2}$.lbs. not 1.lb as in the case of cottons etc., So, if you write in and ask for "enough yarn to make 5 yards of tweed", I work thus:-

A 9 cut yarn has 1800 yards to the pound, so, assuming you will sley at 14 e.p.i. and wishing to finish up with a piece of tweed ready for the tailor of 5 yards x 27" width, I would take 450 ends and calculate that you should have a warp of $6\frac{1}{2}$ yards to allow you to weave at least $5\frac{1}{2}$ yards. This will need 2925 yards for the warp alone, approximately 1.1b. 10.oz. Now you will, no doubt, weave this in a twill which gives a closer weave and you should lay about 16 picks to the inch, so for weft a little more. Therefore, I should send you $3\frac{1}{2}$ lbs of tweed yarn.

Work these figures out for yourselves and I am sure you will soon get the hang of it and feel you have achieved something.

BOOKS FOR THE HANDWEAVER.

From time to time new books for the Handweaver come into the Craft Shops and I am always interested to see them so that I may judge whether they are worth stocking for "LOOMCRAFT" readers. Two new ones were brought to my notice just before Christmas which were offered by an American house. One was about Lacey Weaves and the other deals with the Crackle Weave. So, I sent for them, and after studying them I think that they are useful text books for the more advanced weaver who does not think that 30/- is too much to pay for a semi-stiff covered book of approximately 60 pages.

The Lace and Lacey Weaves covers more than four harness weaving but is still a most interesting publication. Each pattern is given with instructions for weaving a sampler strip, usually 6 or 7 inches wide. This does help the weaver to decide whether the particular draft appeals without setting up a full width warp.

The second book of a like size and price covers Crackle Weave only. It shows how the drafts are composed, how they can be altered and again, gives full instructions for setting up sampler strips as initial projects. Not all the patterns are for four shaft looms, but even so, I thoroughly recommend it for the practical weaver who wants to learn even more about the exciting things a loom can produce.

A good twelve months ago I told you about the Four Harness Huck which was certainly no newcomer to the book shelf, but again something which called the attention of the weaver back to its pages, time and time again. My first batch were soon sold and I have re-ordered several times. All the drafts are for 4 shaft looms and the many illustrations show the kind of work you can produce.

The two Swedish Books by Malin Selander are still proving very popular - I prefer the first one, but both are good. Now it is possible to obtain it more freely in Great Britain through the wholesale distributors appointed over here, but the price has risen to 40/- per copy.

The Handweavers Pattern Book, by Porter Davison is, of course, still a firm favourite and contains a wealth of patterns with full weaving instructions. It does not set out to teach you how to weave, but what to weave.

The two Weavemaster Books are still available; the Recipe Book contains many drafts for tweed weaving and some overshot patterns, also for weavers interested in Tartan Setts this book gives many of these in great detail. The Rug Making Book is a good investment, both for woven pile and tapestry rugs, and is also extremely useful for charts needed when hooking or stitching rugs.

Weaving for Amateurs, by Coates is an excellent book and medium priced covering spinning, dyeing and weaving. All these subjects are dealt with from the initial stages.

SALES AND WANTS.

FOR SALE. DOUGLAS ANDREW Warping Mill with Heck Block and Spreader.
30 yard lay. Excellent condition. Only reason for sale
is space needed. £10.
DOUGLAS ANDREW "Kentish" Foot Loom 42" with fly shuttle
system. All accessories. £30.
Apply:- Mrs. Newman, 29 Lansdowne Road, Canterbury.

FOR SALE. DOUGLAS ANDREW "Canterbury" 4 shaft Foot Loom 32" width.
All accessories. £17.10.0.
Also, WEAVEMASTER 20" 2 shaft Table Loom. What offers?
Apply:- Mrs. Freeman, 32 Douglas Road, Herne Bay.

WANTED. A Village Settlement for mentally handicapped young
people is looking for a Weaver to build up a small industry
with a group of the young people who have already developed
some skill in weaving. Married couple considered.
Apply:- Secretary, Ravenswood Village Settlement,
Crowthorne, Berks.

BOOKS WE CAN SUPPLY.

Weavemaster Pattern Draft & Weaving Recipe Book ...	7/6d.	+ 6d.	Post.
Weavemaster Successful Rugmaking... ..	8/6d.	+ 6d.	"
Woven Rugs, by Grierson	4/6d.	+ 6d.	"
Sample Tartan weaving, by MacDonalld	5/-	+ 6d.	"
Handweaving, by Cherry.	6/-	+ 6d.	"
Weaving for Amateurs, by Coates	18/-	+1/-	"
Weaving Patterns, by Selander..	£2. 0.0.	+1/6d.	"
Swedish Handweaving, by Selander... ..	£2. 0.0.	+1/6d.	"
Four Harness Huck, by Neher	£1. 1.0	+ 6d.	"
The Crackleweave, by Snyder	£1.10.0	+ 6d.	"
Lace & Lacey Weaves, by Snyder.	£1.10.0.	+ 6d.	"
Handweavers Pattern Book, by Porter Davison	£2.15.0	+2/-	"
Shuttlecraft Book of American Handweaving, by Atwater..	£2.15.0	+2/-	"
Handbook of Weaves, by Celsner	£2. 0.0	+2/-	"
New Key to Weaving, by Black... ..	£4. 0.0.	+2/-	"

Lithographed by:- Hythe Printers Ltd., of 2 Marine Walk Street, HYTHE.

LOOMCRAFT

Single copy 1/3d., post free.

5/- per year inc.post.

BY WEAVERS—FOR WEAVERS—ABOUT WEAVERS

Volume Three

JULY 1963

Number 6



Editorial.
Cot Cover.
Place Mats.
New Special Offer
Yarns.
Advanced Pattern.
Tweed with Woven
Sample.
Cushion Cover.
Bath Mat.
Cross Stitch Books
Autumn Closure.
From our Postbag.
Sales & Wants.

"LOOMCRAFT" is issued
Jan. April, July & Oct.

57, CASTLE STREET, CANTERBURY, KENT.

Tele. Canterbury 3935

57, Castle Street,
CANTERBURY,
Kent.

July 1963

Dear Weavers,

I hope that the several small articles which we have given in this issue will help you to begin your gift planning for Christmas! I know it is a long way off, but to prepare some of the smaller gifts that can be woven on small looms easily moved into the garden, you may like to do this during the Summer months. The costs have been kept down to a minimum in order to help the pocket!

One of our most avid readers died a few weeks ago, Mrs. Netta Muskett, the novelist. We shall miss her cheery letters and many queries which arrived from time to time. She had been promising to come to Canterbury again for another refresher course as soon as her health improved, but unfortunately, we shall not have the pleasure of her visit now.

Please give attention to the one week in September when we are closed for part of the staff holidays. Whilst we are always pleased to hear from you, we do not like it to take the form of a complaint that the order you have particularly wanted was delayed for ten days.

We all hope that you will have a happy Summer and if you can call to see us, please do so - we have lots we should like to show you! For friends entering Canterbury on the A.2 from London, we would suggest you take the City ring road. Proceed along this until you reach the roundabout with the Norman Castle on the left. Take the road on the left which is Castle Street, and the first turning on the left is Rosemary Lane where a large FREE car park is now in use. We back on to this so it is only a few steps to call and see us.

With every good wish,

Sincerely yours,

(MRS) MARGARET A. NORRIS.

A COT COVER FOR THE NEWEST ARRIVAL.

In May 1959 we gave a pattern for a pram cover which even now is still being made and re-made by our readers. It was woven in Nylon Double Knit which is so easy to wash and does not shrink. Therefore, I will give you instructions now for a Cot Cover, but this time with a simpler threading and the introduction of a little colour according to your needs.

It will take 12oz. of Nylon Double Knit in White which I can supply at 1/7¹/₂d per ounce if you cannot obtain it locally. Also, you will need 2oz. of a coloured Nylon Double Knit, but I do not stock this, but I have no doubt you will be able to purchase this locally. Actually, you can use ordinary Double Knitting Wool if you have the colour by you.

Make a warp of 230 ends with White Double Knit Nylon, 1¹/₂ yards long and thread the healds single throughout in plain threading - 1, 2, 3, 4. Sley a 10 dent reed singly, except for the first and last 2 dents which should be double to make a good selvedge.

When you are ready to start weaving proceed as follows:-

12 rows of plain weave using 1 & 3, 2 & 4 alternately with White Nylon. Now take the coloured Nylon and lay in the "Dots" as follows:-

<u>1st. Dot.</u>	Use shafts	1 & 2	Coloured Nylon.
		1 & 3	White Nylon.
		1 & 2	Coloured Nylon.
		2 & 4	White Nylon.
		1 & 2	Coloured Nylon.

Now we need 5 rows of plain weave with the White.

<u>2nd. Dot.</u>	Use shafts	3 & 4	Coloured Nylon.
		2 & 4	White Nylon.
		3 & 4	Coloured Nylon.
		1 & 3	White Nylon.
		3 & 4	Coloured Nylon.

Repeat in this order with the 5 rows of plain weave in White after each row of Dots.

Weave until 33 inches have been achieved; Now finish off with 12 rows of plain weave in White Nylon to match other end.

Remove weaving from the loom and use the wide blanket ribbon, either in White or to match the colour of your Dots, to bind all round. Now you will find you have a very delightful Cot (or Pram) Cover that will wash and wear indefinitely. The size of this when finished will be approximately 34" x 22", which allows plenty for turning down if desired.

PLACE MATS WITH A DIFFERENCE.

We are always glad to hear from readers about their experiments with the odd length of warp which are left at the end of a project. So often they are cut off and wasted which is rather a pity in view of the fun and experience which can be obtained from them.

Just after the April number was sent to print, we received a delightful table mat which had been created in just this manner, and I asked Miss Harriott of Gosforth, Newcastle-on-Tyne, to allow us to use it in "LOOMCRAFT" and she very kindly agreed - so, here it is!

Unfortunately, the 10/3's Bleached Cotton which she used has all been sold, but I have adjusted the draft to suit a 16/3's Unbleached Cotton which I can offer to you, together with some Rayon Singles for the stripes of colour which occur every 2 inches in both warp and weft.

The 6oz hank of 16/3's Unbleached Cotton and a $\frac{1}{4}$ lb tube of coloured rayon are offered together at the special price of 4/- complete. The colours we can offer are Pale Blue, Pink, Rust, Maroon and a small quantity of Scarlet. If you send for this on its own please remember to add 1/3d. extra for pack and post, but if you are ordering this with other items, add all the weights together as usual.

Now to give you full instructions for making these. Lay a warp $2\frac{1}{2}$ yards long of 302 ends in the following order:- 42 cotton, 2 rayon, 3 cotton, 2 rayon, 3 cotton, 2 rayon, 3 cotton, 2 rayon, 3 cotton, 2 rayon, 42 cotton, 2 rayon, 42 cotton and 2 rayon. This brings you to the centre so reverse the order, omitting the centre 2 rayon. This will give you the 302 ends needed.

The heald threading is single throughout in plain weave, 1,2,3,4, and the reed is a 14 dent sleyed 2 & 1 alternately throughout, except for the first and last 2 dents which are sleyed double to give a firmer selvedge.

When you have the loom fully dressed and ready for weaving proceed as follows:-

$1\frac{3}{4}$ inches with cotton using shafts 1 & 2, 1 & 3, 3 & 4, 2 & 4, repeated.

Now the coloured border:- 1 & 2, 1 & 3 with rayon; 3 & 4, 2 & 4 with cotton; 2 plain weave rows with rayon; 1 & 2, 1 & 3 with cotton; 2 plain weave rows with rayon; 3 & 4, 2 & 4 with cotton; 2 plain rows with rayon; 1 & 2, 1 & 3 with cotton ending with 3 & 4, 2 & 4 with rayon.

Weave a further $1\frac{3}{4}$ inches in cotton using the same lifts as for the first $1\frac{3}{4}$ inches. Two rows of plain weave with rayon completes this. Now weave two more squares of cotton with 2 rows of plain weave rayon dividing them.

Contd. on Page 5 opposite.....

NEW SPECIAL OFFER YARNS.

SNARL. We have been fortunate in finding some natural Snarl which we are happy to offer in addition to the Beige and Apple Green already on our list. The Natural works out at the same price, 10/- per pound, and I need hardly tell you of its uses for Bath Mats and rough towels. Also, do not forget that it is strong enough to use as warp stripes in Bathroom and Toilet curtains if used with a 7 dent reed. It helps to make the texture so exciting.

SLUB. For a soft hand towel we have been able to buy a quantity of soft medium slub which is quite inexpensive at 5/- per pound (minimum quantity we can supply being $\frac{1}{2}$ lb). It is Off White only, but with a coloured cotton of your choice, it will be ideal.

W.W. RANGE OF YARNS.

When we were up in Manchester at the end of April, we made arrangements for several new lines which will be added to our W.W. range of yarns. There will be a limited number of standard colours in 12/2's and 6/2's plain yarns and also another coloured gimp in the six shades we already offer. This will not be so smooth as our present stock, but we shall of course, continue to stock this as well in order to give our customers a wide range to choose from. More of this in the Autumn issue.

WHAT CAUSES A COTTON TO BE MERCERISED?

Cotton is treated with a solution of caustic potash or soda which gives it a lustre to strengthen it. The method was discovered in 1850 by John Mercer and the process was given his name. Mercerisation gives cotton a high affinity for dyes.

PLACE MATS WITH A DIFFERENCE. (contd., from Page 4)

Repeat the border to match and then $1\frac{3}{4}$ " of cotton in pattern. Now leave a space sufficient to give a half inch fringe each on the first and second mats, and then proceed to weave the next five in this manner. Hemstitch the ends of the mats with the rayon, this gives a pleasing finish and then steam press to set the threads. The mats should be 14" x 10" plus small fringe (top and bottom) finished.

I hope you will find these very useful for Sales of Work etc., they are most attractive and inexpensive.

HAVE YOU TRIED BOUND WEAVING?

Some text books refer to this as Italian weaving, but be it that or bound weaving, it is very interesting and attractive.

Let us take a fairly simple draft and try it for ourselves. The principle is that instead of the usual binder pick of 1 & 3 or 2 & 4 after each pattern row, the opposite lift to the pattern lift is used to bind it.

Suppose we sett up for a cushion cover using 12/2's for the warp. Make a warp of 581 ends by 5ft long which will give a width on the loom of almost 21 inches, and the finished cushion cover will be 20" x 20" approximately. The healds should be threaded single throughout and a 14 dent reed double sleyed to give 28 e.p.i. The pattern draft will be found on the insert sheet in this magazine.

When the warp is threaded and the loom is ready, weave 1" of plain weave with the 12/2's Cotton. Now using 6/2's Mercerised Cotton in two colours, Light and Dark for the weft, weave as follows remembering each lift is used once only:-

<u>Shafts.</u>	<u>Colour.</u>		<u>Shafts.</u>	<u>Colour.</u>		<u>Shafts.</u>	<u>Colour.</u>
3 - 4	D		1 - 2	D		3 - 4	D
1 - 2	L		3 - 4	L		1 - 2	L
2 - 3	D		2 - 3	D		2 - 3	D
1 - 4	L		1 - 4	L		1 - 4	L
1 - 2	D		3 - 4	D		1 - 2	D
3 - 4	L		1 - 2	L		3 - 4	L
4 - 1	D		4 - 1	D		4 - 1	D
2 - 3	L		2 - 3	L		2 - 3	L
1 - 2	D		1 - 2	D		3 - 4	D
3 - 4	L		3 - 4	L		1 - 2	L
2 - 3	D		2 - 3	D		2 - 3	D
4 - 1	L		4 - 1	L		1 - 4	L
3 - 4	D		3 - 4	D		1 - 2	D
1 - 2	L		2 - 1	L		3 - 4	L
4 - 1	D		4 - 1	D		4 - 1	D
2 - 3	L	contd.....	2 - 3	L	contd...	2 - 3	L

D = Dark Cotton. L = Light Cotton. Repeat these lifts for 40 inches.

Complete the weaving with a further inch of plain weave for the hem. When the work is off the loom, turn the plain weaving down to make a hem and then join up the sides to form the cushion cover. If you place the opening in the middle of one side, a zipp fastener can be used for closing the cover instead of the usual slip-stitching.

This pattern would work up well in a towel using 12/3's plain cotton for the warp and two colours of fine gimp for the weft.

STOP PRESS NEWS.

BATH MAT (articled on Page 9 "LOOMCRAFT Vol3 No.6.)

We very much regret an error in the above article. The warping instructions should read as follows:-

"These two stripes should be repeated 12 times (24 x 12 = 288) plus 2 white at either side for selvedge gives 292 ends".

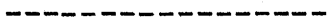

BOUND WEAVING. (Articles on Page 6 "LOOMCRAFT" Vol.3.No.6.)

Pattern Draft.

4	4	4	4 4 4	4 4	4 4 4	4	4/4	4	4
3	3	3	3 3 3	3	3	3 3 3	3	3 3	3
2	2	2 2	2 2 2	2	2	2 2 2	2 2	2	2
1	1	1	1 1	1 1	1	1 1	1 1	1	1

Selv.(7) Final Bal. One pattern repeat (40)..... Selv.(7) Shafts.
(7)

First Selvedge.....	7	Foot Loom weavers please
14 Patterns (40)...	560	note Standard tie-up for
Final Balance.....	7	pedals.
Last Selvedge.....	<u>7</u>	
	581	ends.



TWEED WEAVING WITH WOVEN SAMPLE.

Here is the third example of tweed which we have chosen for our readers. This will appeal to weavers who like a straight forward threading with the same thickness throughout.

We used the Scottish Tweed yarn of medium weight and sett it at 14 e.p.i. Two colours were used in the warp, 3 ends of yellow and one end of black - in that order!



Lay a warp of 452 ends which will give a width of 32" in the reed. The first and last two should be double sleyed for the selvedge. This has been allowed for in the calculated 452 ends.

When threading the healds the 3 yellow should be on the shafts 1, 2 & 3, with the black on the fourth shaft. Thread single throughout in plain - 1, 2, 3, 4. The weaving was on the principle of the balanced twill weaving, but instead of repeating the usual four lifts, it was extended to six as follows:-

<u>Shafts.</u>	<u>Times.</u>	
1 & 2	1)
2 & 3	1)
3 & 4	1)
4 & 1	1)
3 & 4	1)
2 & 3	1)

Repeat throughout.

We used Blue for the weft throughout and as you will see from the sample it made a very fine combination. Also, Tan in place of the Blue gives a very warm effect.

Allow 9 ounces of yarn for the warp and weft to give a yard of tweed sett as given above. This means that approximately 2 $\frac{1}{4}$ lbs of Blue for the weft and 9 ounces of Black and 1 $\frac{3}{4}$ lbs of Yellow would produce an eight yard length.

If you purchase the yarn from us and would like us to process it, we can undertake this at a cost of 1/9d per yard or part of a yard, plus the postage. Please allow up to 14 days for this service.

If you like definite stripes and are thinking of a suit or coat length for the winter, then I would suggest you wait for the October Number which will have such a pattern. For those of you who would like advance knowledge, a sample of this can be sent now upon receipt of a stamped self-addressed envelope.

CUSHION COVER IN PLAIN WEAVE.

Quite a number of our readers have 2 way looms which they find useful for carrying into the garden during the Summer months, and often they say that they are restricted in its use by virtue of the fact that pattern work can only be achieved by pick-up weaving which is rather slow.

Here is a suggestion for two cushion covers which can be woven on either a 2 or 4 shaft loom using 12/2's cotton and white rayon gimp. We also make a special offer to our readers of $\frac{1}{2}$ lb of Egyptian 12/2's cotton and $\frac{1}{2}$ lb of white rayon gimp - enough for two covers measuring 18" x 16" finished, for 8/6d., complete. If you send for this offer on its own it will cost another 1/6d., for packing and postage, if however, you include it with other items when ordering, then you calculate it in.

If you have a 14 dent reed then you will need 423 ends and these should be warped $2\frac{1}{2}$ yards long to allow just under a yard for the cushion covers and the residue for tie-on and loom wastage.

Thread the healds single; for a 2 shaft loom it is 1, 2, repeated throughout; if a 4 shaft, then of course, it is 1, 2, 3, 4 to give plain weave. The reed should be sleyed first and last 2 dents double but the remainder is 1 & 2 alternately.

Commence the weaving with the cotton for $2\frac{1}{2}$ inches, now use the gimp in the same manner for $\frac{1}{2}$ ". Weave with the cotton for 1" only and repeat the order, using first gimp for $\frac{1}{2}$ " and then cotton for 1", finishing off with $2\frac{1}{2}$ " of the cotton so that the length is $35\frac{1}{2}$ ". Now make a cutting line by using a waste cotton for 2 picks to show where the first cover finishes and the second one begins. Work in the same manner for this and then remove the weaving from the loom and cut the two covers apart.

Now draw a thread down each selvedge about $\frac{1}{2}$ " in and either machine stitch or hemstitch along on the inner side to hold the warp ends when you fray the $\frac{1}{2}$ " to give the fringe.

When this is done, turn in an inch hem at either end, then join up the sides, carefully matching the fringes. I rather like the idea of making the opening in the middle of one side in which case it is easier to slip-stitch the two sides together after the cushion is in position. Better still a zipp fastener can be used.

The colours available in the Egyptian cotton are Deep Pink, Salmon, Dark Green, Navy, Royal Blue, Gold and Maroon. Please note that we cannot supply less than $\frac{1}{2}$ lb. of any colour.

This threading and the amount of yarn allowed will, with care, produce six table mats with $\frac{1}{2}$ " fringe all round, finished size 18" x 10".

A BATH MAT ON A TWO SHAFT LOOM.

An easy to weave Bath Mat is always a firm favourite and this one can be made for 10/-. We will send you 1 lb of Off White Thick Cotton and Rayon Yarn and $\frac{3}{4}$ lb of a coloured thick Weaving Cotton which will produce a mat 22" x 44" plus fringe when finished.

You will need a 6 dent reed which must be double sleyed to give a setting of 12 e.p.i. Make a warp of $1\frac{3}{4}$ yards as follows:-

2 White for Selvedge.

First stripe. 1 White) Repeat
 1 Colour) 6 times.

Second stripe. 1 Colour) Repeat
 1 White) 6 times.

These two stripes should be repeated 16 times ($24 \times 16 = 384$ ends) and then 2 White for the final selvedge. They are threaded singly in the healds throughout and kept strictly in this order. The 6 dent reed is sleyed double to give 12 e.p.i. and 24" wide. If you cannot weave 24" wide, then adjust the length so that you can weave in narrower strips and join them.

Four shaft weavers know, of course, that they simply use all four shafts threaded 1, 2, 3, 4 and operate the lifts to give 1 & 3 then 2 & 4 for plain weave. Otherwise the instructions are the same.

Now you are ready to begin weaving, which all depends upon the sequence of the weft shots. Fill two shuttles with cotton, one of each colour and use them alternately until you have woven 12 picks (6 of each colour). Now reverse the order so that the second 12 begins with the same colour as the last of the first 12 rows. This simply means that you have 2 picks of the same colour. Continue in this manner until the weaving measures 44"; always beat well to give a firm texture. This will give a checked basket weave which looks most attractive.

Remove from the loom and use the tie-on knots at the beginning to make the fringe length at one end, the other can easily be allowed for by cutting the warp behind the shafts.

Make neat tight knots of four threads at a time as close to the weaving as possible. Then trim off to give a fringe $1\frac{1}{2}$ " to 2" at either end. You may like this pattern and wish to make Bathroom curtains to match, but using 6/2's cottons sett finer. We shall be very happy to advise you regarding quantities etc., Samples of the above mentioned thick weaving cotton will be sent on request with a stamped self-addressed envelope. Colours available are Royal Blue, Pale Blue, Pink, Scarlet, Maroon, Soft Green and Gold. Please add postage to the 10/- for this special offer.

CROSS STITCH BOOKS.

If you are like us you cannot resist a good pattern book! We are always looking for patterns with an easy to follow graph system as these are useful for weaving laid-in work and the heavier patterns can be adjusted for knotted rugs. Where the weaver is also a needlewoman, the books serve a dual purpose.

For some time we have been selling the Danish Cross Stitch Book at 3/- including postage; now we are able to offer six French Books on similar lines. Three are by D.M.C. and offer Borders and All-over patterns, these are 2/6d., each including postage.

The others are larger publications by Thiriez & Cartier-Bresson, two of them offer complete pictures in graph as well as motifs and borders; then the last one gives dainty borders and motifs and wider borders with heraldic figures etc., The last three books are offered at 5/6d., each including postage. A very useful thought for Birthdays etc.,

AUTUMN CLOSURE.

Two years ago we closed down completely for one week in the Autumn and we were able to get one week of our holidays over without dragging on several weeks with only part staff. Last year, owing to our move, we did not do this, but it was such a success in 1961 that we shall repeat it again this year. We all find that an early holiday between Easter and Whitsun sets us up for the Summer rush, and then another complete break just before the Autumn magazine is issued gives us a chance to get ready for the heavy mailing business which comes between October and the New Year. Therefore, please bear with us and remember that the first week in September (2nd to 7th inc.) we shall be closed in all departments and your letters will pile up behind the door.

As soon as we are back again, September 9th. onwards, we will push ahead with any accumulation which we find, so please, urgent orders by the last week in August or hold over until September 9th. Many thanks.

POSTAGE AGAIN!

Just a reminder that now it is permissible to send up to 22lbs. by parcel post. This is a great help where several weavers send in bulk orders for yarns. Some prices have changed since our last issue but the local Post Office will always help you. Please remember to add 6d. extra to the figure quoted - 3d. to cover the extra pound we must break into in order to wrap your parcels securely, and 3d. for the actual time and extra paper and string this takes. After all we cannot pass your order to the Post Office in a paper bag as we do to visiting customers and it all takes time and materials.

Overseas customers please note that some Overseas rates have been increased.

FROM OUR POST BAG!

We have not been able to spare a page for readers news for some time now, but as Mrs.G.V.Jones of Southampton reminded us by saying, "I always enjoy your magazine, it is so bright and full of helpful ideas for better weaving and I do so enjoy the little human bits of news of other weavers and how they cope", we have decided to find the space this time!

First a tip or two which other readers may find useful too. Mrs.M.K.Box, of Ludbrook, South Devon, sent us this idea:- "In the Spring I made two very successful pram covers, based on the Swedish lace you gave for linen trolley cloths in the August 1961 number of "LOOMCRAFT". I used double knitting threaded at 8 e.p.i. and by adjusting the repeats produced squares of about 2 inches. The warp was in Blue and White, while one weft was Pink and White and the other Yellow and Blue. The ends were bound in satin ribbon. The resulting covers were light, soft and warm and have been much admired".

After the rigours of last winter, I am sure many of you will appreciate the idea sent in by Miss E.E.Moody, of Haywards Heath:- "If anyone is interested, I have found a use for long narrow bits of weaving samplers - made into a tube, stuffed from each end with cut up foam (bags of it can be purchased from Woolworths), or other stuffing, tied tightly with a tassel at each end, it makes an attractive draught excluder for the winter. Used in one's home, one still has the sampler to hand!! Also, I should think that smaller pieces would make the door stops which hang each side from the handles."

Now for the little human touches that we really do enjoy reading from our post-bag! Mrs.H.Breckels of Hambro Hill, Rayleigh said this to us in a letter advising us that she had just moved house - "Once we get really unpacked I'm hoping to do more "looming", to quote my son, and even when this has been impossible, I've loved reading "LOOMCRAFT" - one of these years I'm coming to your Instruction Classes - do you have classes for small boys? + I don't mean this seriously as my small son would undoubtedly think up an idea for improving things or even invent a new type of loom altogether!"

From another busy mother, Mrs.R.Showell, of Sutton Coldfield, we enjoyed reading her letter which said:- "Weaving activities are at a stand-still at the moment. My hobby has got so out of hand (according to my husband and children) that we are having the roof of our house made into a proper loft-room for me, plus looms, warping mill, spare reeds etc., etc., I have now got four handicapped people weaving on small looms - one does beautiful work, two are doing fine, but number four insists on weaving dish-cloths only - she says she likes doing them and thats that!"

As always we do like to hear that our readers are pleased with their weaving projects - Mr.H.F.Marshall of Penn, Wolverhampton writes, - "When I wear my Shepherd's plaid waistcoat, I remember the pleasure I had in seeing it from wool to garment. A pleasure equalled by the reading of "LOOMCRAFT" which gossips and instructs so happily on weaving matters."

SALES & WANTS.

FOR SALE. "CANTERBURY" Loom. Reed 30", usual accessories. As new. £12.
Apply:- Champion, 10 Palmerston Court, Clarendon Parade, Southsea.

FOR SALE. "DOUGLAS ANDREW" Foot Loom 42". 4 shafts, 6 pedals. All accessories
inc. 3 reeds. Warping Board, Spool Rack, Bobbin Winder and Stool.
Excellent condition. £30 o.n.o.

FOR SALE. "Handweavers Source Book", by Marguerite Davison.
"Shuttlecraft Book of American Handweaving", by Mary Meigs Atwater.
"Weave your Own Tweeds", by Roger Millen.
All new condition. What offers?
Apply:- Box No.96 "LOOMCRAFT", 57 Castle Street, Canterbury.

NEW AND SECONDHAND TABLE LOOMS AND EQUIPMENT FOR SALE. SPACE NEEDED.

- 20" Secondhand 2 shaft "WEAVEMASTER" 14 dent reed 9½" wire healds.
Perfect condition and complete. £3.0.0.
- 15" Douglas Andrew "HOMEMASTER" 4 shaft loom. Completely new.
12 dent reed, cord healds, complete with shuttles. £7.10.0.
- 12" Douglas Andrew "EASYMASTER" 2 shaft loom 4¾" wire healds. Completely new.
14 dent reed, complete with shuttles. £3.10.0.
- 12" Secondhand Douglas Andrew "EASYMASTER" 2 shaft loom.
3 dent reed, 4¾" wire healds. Complete with shuttles. 30/-
- 12" Secondhand Rigid Heddle Loom. Good condition. 20/-
- 9" Kamar Rigid Heddle. Completely new. 35/-
- Swedish Wooden Wool Winder. Clamps to table. Completely new. 25/-

GARDERS FOR HANDSPINNING.

- 1 Pr. New Garders (Swedish?) 30/- pr.
2 Prs. Secondhand but excellent condition. 20/- pr.

ALL ABOVE ARE CARRIAGE OR POST EXTRA. PACKING FREE WHERE POSSIBLE.

Apply to:- CATHEDRAL WEAVING CENTRE, 57 Castle Street, Canterbury. Tele.3935.

LOOMCRAFT

Single copy 1/3d., post free.

5/- per year inc.post.

BY WEAVERS—FOR WEAVERS—ABOUT WEAVERS

Volume Three.

OCTOBER 1963

Number 7.



Editorial.
Cocktail Dress
& Stole.
Bedside Rugs.
Xmas Suggestions.
Evening Bag.
Tweed with Woven
Sample.
Weaving Books for
Christmas.
Oven Glove.
Gimp Towel with
Odds & Ends.
New Year Changes
for Loomcraft.
Sales & Wants.

"LOOMCRAFT" is issued
Jan. April, July & Oct.

57, CASTLE STREET, CANTERBURY, KENT.

Telephone:- Canterbury 3935.

57, Castle Street,
Canterbury, Kent.

October 1963.

Dear Friends and Weavers,

Perhaps you think this is a strange way to start a letter, but so many friends take the trouble to write from time to time and amongst those letters it is not uncommon to find one which states that although no weaving is being carried out nowadays, there is still the interest there sufficient to continue taking LOOMCRAFT. That, to my way of thinking, is just another kind thought which always gives me great pleasure. Thank you all, very much.

Well, here we are at the end of yet another year's weaving, and still I do not seem to have had time to complete all the projects I had planned! I do hope that you have been more fortunate and have much to show for your plans and labours. We, here at LOOMCRAFT, feel that when you write, or call to see us and tell us that you have woven the different patterns from your magazine, that all the weeks of working out articles has been worth the time and trouble.

Only today I remarked to Mrs. Hunt about a series I have in mind for 1964, and she laughed and said, "Always one jump ahead!" It is quite true, we do try to be just that, and some of the discussions we have over the mid-morning breaks are at times frightfully amusing and we enjoy them immensely.

As you will read in this issue we are aiming to improve LOOMCRAFT a little more by giving you some illustrations starting next January - we have our fingers crossed, but hope that the idea will please you.

On the insert we have only given a shortened list of standard lines, this is because we included a printed list of these, together with our equipment list, in the last issue, but if you have mislaid yours please do not hesitate to send a stamped, self-addressed envelope and we will forward another for your reference. On the shortened list we have tried to give you just the items dealing directly with the articles in this issue.

We regret that we cannot include the yardage of the various yarns on our lists, but we have from time to time given you instructions how to arrive at this for yourselves, also, we do try to give you an idea how much the various patterns need. We hope that you will understand.

So, although it will be something like ten weeks before Christmas is here, we know that these are going to be very busy ones for all weavers. We, too, expect to be busy sending off your orders, but we do say with all sincerity, "Have a wonderful time, both weaving before Christmas, during Christmas and the New Year itself."

Very sincerely yours,

(Mrs) Margaret A. Norris.

A COCKTAIL DRESS & STOLE IN FINE WOOL AND LUREX.

With the present trend towards simplicity in evening wear, we have been commissioned to weave and tailor several very straight Cocktail dresses, with scoop neck-line and sleeveless.

These are extremely easy to weave, and we feel that some of our weavers would welcome a little advice about these. Therefore, we thought we would take you through the motions of weaving such a dress and also a stole to match.

You will need to have either a ten dent reed or a fourteen dent reed which would be threaded 2 and 1 alternately to give 21 e.p.i., but a ten dent double sleyed would be better. The dress and stole will take one lb of 2/24's fine wool, and spool of Lurex of the 1/64" thickness which we can supply. Although the spool of Lurex contains more than you need, it may be useful as the binder thread if you are thinking of weaving the Evening Bag, given in this issue, to complete the picture. Also, the small amount of 2/24's fine wool can also be used on the bag, but more of that later.

We find that 23/24" width gives enough for the average size, but adjust this if you are planning a dress for a larger size than 36/38" bust. Lay a warp of 500 ends with the wool in a colour of your choice, and then sley the reed double with it if a 10 dent reed, but allow 520 ends if you are proposing to use a 14 dent reed sleyed 2 and 1 alternately. The warp should be a full six yards long to give 3 yards for the dress length, and then a gap of 8 - 10 inches before weaving the stole length which should be 2-2½ yds plus the unwoven warp at the end for the other fringe.

The healds are threaded single and in plain setting of 1,2,3,4, repeat, and when the weaving commences it should only be laid and not beaten. In other words the batten should be used with care so that the weft picks lay even.

We made our dresses with two inches of weaving in the wool only, and then one inch with alternate picks of Lurex and wool. We used a multi-coloured Lurex and the various colour changes gave the illusion of a patterned stripe, but this was not so - it was plain weave throughout.

The stole can be woven in the same manner, using wool on its own and then wool and Lurex alternately, or to give a contrast it could be alternate picks of wool and Lurex throughout. This kind of thing has proved very popular with our Stole customers. When removed from the loom lightly steam press.

Purchase a pattern on the lines we have described above, and complete the dress, but one more word from us, we lined our dresses throughout, it helps them to hang better and we also had slits in the side seams which allow freedom of movement.

The fringe of the stole should be knotted in groups of about 8 ends, close to the weaving, and then at least one more row of knots about 1½ inches lower and the first knots either split or crossed over to give a finished effect. We have seen some with several rows of fancy knotting which have made the stoles.

THE BEDSIDE RUGS WITH MAN-MADE FIBRES ONCE MORE.

In Number 7 of Volume 2, November 1960, we gave an article for Bedside Rugs and Runners using some Acrilan Sliver Tops which I had the good fortune to find on one of my buying trips. This was a great success and the stock I was able to buy was soon gone, and requests for more had to be disappointed.

Now I have found something of the same nature, Terylene Sliver Tops, still in continuous lengths and very suitable for this kind of project. It is, of course, in white only, but the colour element can be introduced by way of the warp or in some instances, the weft. This time I have bought much more, and also at a much more favourable price. We thought, therefore, that a revision of the article in this Loomcraft of three year's ago would be of interest to our new readers and also save our longstanding friends the trouble of looking up that particular number.

We estimate that it will take 2 lbs of Terylene Tops to make a tufted rug for the bedroom, plus one pound of warp cotton to make a rug 24 inches by 48 inches, or one yard square. This should help you to work the quantities for larger or smaller rugs according to your needs. This will cost just under £1 plus the post.

Sett your warp at 6 or 7 e.p.i. according to the reed you wish to use. When you are ready to start the weaving, which has been set for plain weaving, work about one inch of weaving in the warp cotton to make a heading before starting to put in the tufts. We found that 2 inch pieces were big enough but here you must judge for yourself. Each piece will be better for a twist before you make the knot round the warp. Do not forget that you must throw one or two picks of the warp cotton between the rows of knots to bind them.

Finish off the rug with the same amount of plain weaving as you started with, and when you remove the rug from the loom I would suggest that you turn the plain weave under and sew a wide piece of carpet binding over the turn-ins to make a neat finish.

The Terylene Tops can also be used as weft for a Tapestry Rug, and for this I would like you to turn to the Bathroom Mat pattern we gave in the August 1961 issue. No.10 of Vol.2. This was another very popular pattern, so with reduced costs it may appeal to an even wider circle just now.

Again allow 2.lbs of Terylene Tops in place of the Soft Weaving Cotton, and use a brightly coloured warp instead of the plain unbleached suggested. You could also have a still further contrast with the binder thread. I am sure you will find great satisfaction with working out the various colour combinations.

With both types of Rug do please remember to beat well so that you can pack the weft firmly down and make a solid, hard wearing Rug which will, I hope, give you a lot of pleasure, both to weave and to use in your home.

You will find that with a little care you can wash these rugs at home without a spin drier, just pick a fairly windy day so that they can get a good blow. Treat them in the same way as you would when washing Nylon articles and I think you will be pleased.

SUGGESTIONS FOR CHRISTMAS PRESENTS.

As time draws nearer to Christmas it always seems such a job to think of something to make which will be useful, and at the same time as inexpensive and quickly made as possible for you. May we therefore make a few suggestions which you may have seen in back numbers of "LOOMCRAFT" but forgotten? If you do not have the particular copy of Loomcraft stored away, or if you are a fairly new reader and it is before you "joined" us, we shall be happy to send you a typed copy of the pattern in question for a minimum cost of sixpence per copy, plus 3d. for the postage. Just quote the issue as we shall do, and then we will do all we can to send you the information you will need as quickly as possible, but do please have patience with us - we are now coming up to the busy period for post orders, although now I come to think of it we are always busy!

No.3. Vol.1. Stoles and scarves in fine wool. Always firm favourites for almost any age. With the 4/24 wool we have to offer at 24/- lb, on $\frac{1}{4}$ lb tubes, you will produce a somewhat thicker scarf than that shown by the sample, but this is a good thing. For the stole I would suggest that you sett the warp just a little more open, say 16 or 18 e.p.i. instead of the 20 in the article, and lay the weft accordingly.

No.11. Vol.1. In this issue we gave two small patterns which were easy to thread, and easy to weave, yet useful for borders to tray cloths and place mats. Try some cushion covers with one of these patterns throughout the entire length, this would not be difficult, but would be very acceptable I am sure.

No.11. Vol.1. Also in the same issue we gave instructions for weaving some linen which was completely plain, and so very useful for the embroidress. I am sure most people have such friends around them, and what a joy to hear them say at a later date, "Oh yes, the linen is handwoven!"

No.1. Vol.2. In this issue we gave a pattern for a Nylon Pram Cover, and even now we still receive repeat orders for the Nylon to make more and more of these for the newest arrivals. We too, still run them off from time to time as they are still firm favourites amongst our showroom customers - especially the overseas visitors.

No.7. Vol.2. In this Christmas issue we have a two page spread that will be of great value to the new reader. Firstly there was Shetland wool scarves and here we suggested that two scarves on the same warp would be a saving of time and money. They were quickly woven and if you follow our instructions to only lay the warp and not beat, they will be soft, warm and very popular! Secondly we suggested Mohair Cravats and here again they are a quickly made gift, perhaps you may wish to make these at the very last minute. The last suggestion in this number was for Trolley Cloths which are always popular amongst the housewives, and if they are like me, never too many! The cottons we suggest are still available and I am glad to say with an even wider range to choose from.

No.9. Vol.2. Finally, what about a run of Book Markers? Sett up in a pattern that will allow you to make some in pattern and some in plain weave.

AN EVENING BAG TO MATCH THE COCKTAIL DRESS.

Having made the suggestion that a Cocktail Dress and matching Stole would be fairly easy to weave, we thought that we should complete the picture with an Evening Bag, so with black 12/2's for the warp we got to work, and the following instructions were the outcome.

We used 12/2's Mercerised Black Cotton for the warp, but according to your colour scheme this can, of course, be changed. You may have some of this by you, but if not, then you will need a 1/2 lb tube of your colour choice. A fourteen dent reed was used and double sleyed. The healds were threaded single throughout.

Two types of evening bags were sampled, and I have given the measurements needed for weaving both of them on the same warp. This is because it takes so little for either one that you may find it a good thing to warp up for two or more, using the extra ones for Christmas presents. Black is such a good warp colour for anything of this nature, so do think hard about what you will want to do with the handbag you make for yourself as it will, no doubt, outlive the dress and stole.

The envelope type of bag takes 18 inches of weaving, but the evening bag with a metal top only needs a maximum of 12 inches, so you see 1 1/2 yards of warp will give you one of each style, and you can then decide which one to keep, and which one goes to your friend!

Lay a warp of 316 ends which will give you a little over 11 inches width on the loom, and approximately 10 inches off the loom. As I have already stated, this is double sleyed into the fourteen dent reed. The pattern threading is as follows:-

Threading Draft.

4	4	4		44	44		44	44		4	4	4	4		4	4		4	
3	3			3	3	3		3	3		3	3	3	3		3	3	3	3
2	2			2			2	2	2		2	2	2	2		2	2		2
1	1	1					11	11			1	1	1	1		1	1		1

Selv.(9) ... Part Two (22).. ... Part One (18) Selv.(9) Shafts.

Thread the selvedge of 9 ends, then Parts 1 & 2 seven times, then just Part 1 once more. This is to balance the pattern. Now complete the threading with the last selvedge of nine ends, which will use up all the 316 ends of your warp. Tie on and make your tension adjustments. You can now proceed with the weaving. First of all weave a heading, about one inch of plain weaving will do, then proceed with the pattern using either the fine wool left over from the dress, doubled in the shuttle, and the Lurex for the binder, or have a one ounce spool of the Art Silk we stock again in a colour to suit your plans. A one ounce spool will be enough for the envelope bag, but you would only need part of the ounce if it is for the bag set in a metal frame.

Continued on Page 8.....

TWEED WITH STRIPES AND PATTERN.

Now we come to the last of our present series of tweed patterns, and I was very pleased to find so many folks took the trouble to write in for a pattern of this one so that they had an idea of what was coming.

There is something of a history to this one, it happened in this way. A customer came in to enquire about a piece of material being copied in tweed. We offered to examine it and give our views. It proved to be a very interesting weave, and when we sampled it in our version the customer was thrilled and commissioned a long coat and skirt to match. Since then we have carried this out in several other colour combinations.



Unfortunately there is one snag which has occurred, and not of our making. This particular colour scheme, (see sample above) cannot be supplied. The spinners decided to curtail several colours without much warning, and our stocks of the Pink and Maroon can no longer be supplied. However, there is a very nice range of Blues, Greens, a Yellow, Orange and a fine Scarlet, also Black and White, so perhaps another combination of colours will appeal to you even better.

A fourteen dent reed was used for this, and although there is an unusual sleying of this, all the threads, irrespective of their thicknesses, are threaded in the healds singly. Please note this carefully as I shall not dwell upon this point again. It is plain threading, vis. 1,2,3,4 repeat throughout.

We used Ice Blue and Pink Scottish Tweed yarn, and Navy 21 cut Shetland for the plain stripes. It was warped in this order:- 1 Pink, 1 Ice Blue, five times, then 1 Pink. Now 4 of the Navy, then 1 Ice Blue, 1 Pink twice and ending with a single Ice Blue. Now repeat the 4 Navy again. This constitutes the pattern, and these 24 ends are repeated for the width required, but try and end after a wide stripe of the Pink and Ice Blue. We sett 32 inches width on the loom.

Now I will remind you once more that the warp ends are single threaded through the healds for the entire width. The reed is sleyed as follows, and I hope that you will watch this very carefully, it can make or mar your weaving!

<u>Sley:-</u>		<u>Contd.,</u>	
1 Pink) 5 times	1 Pink) single
1 Ice Blue) single sleyed.	1 Ice Blue) sleyed.
		1 Pink)
1 Pink) both in	1 Ice Blue) both in
1 Navy) one dent.	1 Navy) one dent.
2 Navy	in one dent.	2 Navy	in one dent.
1 Navy) both in	1 Navy	this is sleyed with the first Pink of next
1 Ice Blue) one dent.		stripe.

Continued on Page 9

Continuation of the Instructions for an Evening Bag. (from Page 6.)

Weaving Lifts.

		Now:-				Now:-		
<u>Shafts.</u>	<u>Ped.</u>	<u>Shafts.</u>	<u>Ped.</u>	<u>Shafts.</u>	<u>Ped.</u>	<u>Shafts.</u>	<u>Ped.</u>	<u>Times.</u>
2 & 3	2)	1 & 2	1)	3 & 4	5)			4
1 & 2	1)	2 & 3	2)	2 & 3	2)			1
1 & 4	6)	3 & 4	5)	1 & 2	1)			4
3 & 4	5)	4 & 1	6)	2 & 3	2)			1
				3 & 4	5)			4

These complete the pattern and the twill part should be woven after the final full pattern has been worked - this completes the bag, and another inch or so of plain weaving should complete each piece. One thing more, do not think that you have made some wrong threadings when you see several instances of two threads rising and falling together in the plain weave, this is quite in order and does not spoil the finished article.

Now to the making up. The envelope type bag will need to be stiffened and the best means of doing this will be to obtain a strip of tailors' canvas as wide as the piece of weaving. The bag should be lined with a material to suit your colour scheme, and two gussets should be let into the sides of the envelope part to prevent bulging when the bag is in use. One large press stud should be fixed on the flap - these can be bought at most general Craft shops.

For the other style of Evening Bag you will need a metal frame, either in silver or gold coloured metal, and when the piece of material has been made into a bag and lined, this should be carefully sewn into the framework using the holes which are stamped ready for this.

If you are not at all happy about making up these bags, why not approach one of your local craft shops for a price to do this for you, but please do not send to us as we are far too busy!

WEAVING BOOKS FOR CHRISTMAS - AND AFTERWARDS.

For the purely four shaft weaving we would recommend the following:-

"Handloom Weaving", by Christopher.	6/- plus postage	6d.
"Successful Rugmaking" by Weavemaster.	8/6d "	6d.
"Weaving Recipe Book", by Weavemaster.	7/6d. "	6d.
"Weaving for Amateurs", by Coates.	18/- "	1/-
"Four Harness Huck", by Neher.	21/- "	6d.
"Handweaver's Pattern Book", by Davison.	55/- "	2/6d.

For books that cater for a variety of shafts we can supply:-

"Lace and Lacey", by Snyder.	30/- plus postage	6d.
"Swedish Handweaving", by Selander.	40/- "	2/-
"Weaving Patterns", by Selander.	40/- "	2/-

TWEED WITH STRIPES AND PATTERN. (Contd.)

The entire weft was in Maroon. When working out your colour combinations for this pattern, do remember to choose a weft which is fairly quiet and something that will merge into the rest of the colours.

Now the weaving is quite simple and I am sure you will soon get the order in your mind. You will see that after each lift, which we call a pattern lift, there is a plain row following, but do not try to alter this or you will spoil the pattern.

<u>Shafts.</u>	<u>Pedals.</u>	
1 & 4	6	These lifts are used once only, and the sequence is repeated throughout.
1 & 3	3	
3 & 4	5	
2 & 4	4	
1 & 2	1	
1 & 3	3	
2 & 3	2	
2 & 4	4	

In the rush to get the magazines out to you once they are back from the printers, it is just possible that the sample may be put in with the side I consider the wrong side, uppermost, but you can soon check this is you look at both sides. The right side is the one with two long warp threads with a dot of the same colour between them. Actually I think that it will appear very obvious to you.

When estimating the amounts of yarn required, allow 5 ozs of one colour for the weft and $2\frac{1}{2}$ ozs each of two colours for the warp, all in Scottish tweed, and 1 oz of 21 cut Shetland tweed for the stripe. I have been fairly generous with the amounts, so if you are aiming to weave a good length, then you could cut off an ounce or two from each of the amounts given. We can, of course, undertake to scour and finish the tweed for you if you purchase the yarn from us. The cost is 1/9d., per yard, or part of a yard, plus the return postage. It is then ready for making up.

AN OVEN GLOVE MAKES A WELCOME GIFT!

For a stocking filler oven gloves are always useful for the house-proud woman, and they are so easy to make. The cost is also so low that one can afford to warp up for several at a time.

We used some inexpensive 8/2's warp cotton and laid a warp allowing 1 yard for each glove, by 8 inches wide, plus $\frac{1}{2}$ to $\frac{3}{4}$ yard for wastage on the loom. A ten dent reed was used and double sleyed, but you will do just as well with a fourteen dent which can be sleyed 2 and 1 alternately to give 21 e.p.i. The threading was plain, 1, 2, 3, 4, repeat, and single through the healds. Either plain weaving or twill will do. For the weft we used the fine slub offered at 5/- per pound, so for $\frac{1}{2}$ lb of 8/2's warp and $\frac{1}{2}$ lb of fine slub you could make four gloves. Weave them 36" long, turn the ends in and then machine a six inch pocket at each end to slip the hands into, and hey! presto! another Christmas thought!

GIMP TOWELS WITH "ODDS AND ENDS."

How often do you look at the remains of spools of cottons which are left after a weaving project, and how often do you think, "I wish I could use them up on something useful," but at a loss to know just what?

This may be the answer to your problem, we hope so! Try two or three hand towels, making them gay and colourful with the cottons you have by you. This is what we would suggest.

First of all gather your cottons together and sort 6/2's from the 12/2's, in other words, the thick from the thin. Now decide which fairly coarse reed you will use. We selected a nine dent but a seven or eight would do, but I do not suggest anything finer than a nine. This is going to be double sleyed, so remember that two threads have got to live together in each dent.

We decided that we would sett the towels to give a finished width of 18", so we laid a warp of 19 inches to allow for a slight waisting on the loom, and also for any shrinkage which may result from the first washing.

Half the warp was of cotton, and half of white gimp, so following our usual practice we made two warps, this being the easiest method for double sleying a reed with two different threads laying next to each other.

Our warp was 2½ inches of yellow, ½ inch of black, 1½ inches of green, 2 inches of yellow, 1½ inches of green, ½ inch of black, then 2 inches of yellow for the middle stripe and repeating from the last black stripe in reverse. This gave us the 19 inches on the loom. Our white gimp then gave one warp end to lay along side each cotton end, except for the black; here we laid black gimp. We then sleyed the reed with first the cotton warp, one end per dent, and then laid the gimp in the same manner so that a cotton and a gimp laid side by side in each dent.

The healds were threaded in plain weave, 1,2,3,4 for a four shaft loom, or 1,2 for a two shaft loom. The weaving was perfectly plain and we used white gimp throughout.

We allowed 30 inches for each towel, and this, plus the amount you need for the wastage and tie-on on the loom, should be calculated carefully. Remember that you need the same wastage etc., for one towel as you do for five or six.

If some of your colours are in 12/2's cotton, then treat them as 6/2's by doubling them and threading throughout in double, this will give you the required thickness. It would be rather a novelty to use two strands of 12/2's together of different colours. They would probably twist themselves together, but it would look rather attractive, I think.

For the gimp, warp and weft, of each towel allow 6 ozs of white and one oz of black, this is sufficient for the stripes of black and the same in the weft. The 30 inches allows for a 2 inch hem at each end, and the towels should be laundered before using to remove the dressing in the cotton gimp.

NEW YEAR CHANGES FOR "LOOMCRAFT".

For a long time we have been aware that something was missing from our set-up for "LOOMCRAFT". We have had friends call to see us, and when we have shown them various woven articles made from instructions published in the magazine, their enthusiasm is good to see, but the remarks are usually on the same lines - "I'd no idea it would look like this!" So at long last we felt that some sort of illustration would have to be included. We then made enquiries about the whole thing being printed, but first of all the price was far beyond what we had expected. It would have meant something like double the price for "LOOMCRAFT", and this I want to avoid as long as possible as I know that so many of our readers are now on fixed incomes when every penny counts. Another point which has turned us against this was that it would have been reduced in size, and here again it is not fair to the middle-aged to elderly readers. We then approached the firm that are at the moment producing "LOOMCRAFT" as it is, and here again we were advised to keep the print in the size now used, but to take the Sales and Wants from the back page, and put this item on the loose page which we duplicate ourselves. Then, with the back page free, this could contain photographs and perhaps line drawings relating to the articles on other pages. The illustrations will be referenced so that it will be easy for you to marry up the related matter.

We therefore propose to start this system with the first issue of 1964. We hope that if there are some shortcomings with the first attempts you will be a patient public and help us to help you. We shall also, as time goes on, advertise more widely. At the moment we do from time to time advertise in the Guild paper, but with a wider public, we may be able to improve even more. Fortunately, the extra cost we feel at this stage should be added to the subsidy we already have from the parent company of Cathedral Weaving Centre, without whose help we could not maintain the already low figure at which we offer it to you.

When I was going through the old numbers of "LOOMCRAFT" in an attempt to find some suggestions for small Christmas presents, I was somewhat staggered to see the kind of thing our earliest readers received and praised with as I can see, such enthusiasm and kindness - thank you all very, very much for all the support you gave our early efforts. We hope that this new move will give you as much urge to weave as the first numbers of "LOOMCRAFT" did.

REPLENISHMENTS OF STOCK.

The first tweed article we gave this year was for a 4 $\frac{1}{2}$ cut knop yarn with the fine Shetland tweed. We had quite a number of readers asking for a knop yarn other than we could offer. Just lately, however, we have had a small consignment of a Bottle Green with dull Gold and a lighter Green in the knops; also a Dull Gold with knops of Red, Gold and a Greeny Blue. We hope that if you are interested you will send for samples. Unfortunately, there is not an unlimited stock and it is a case of "first come, first served".

Remember, a good warp, well laid and carefully dressed, is 90% of a good fabric.

SALES AND WANTS.

FOR SALE. "DOUGLAS ANDREW" Foot Loom 42". 4 shafts, 6 pedals. All accessories. 3 reeds. Warping Board, Spool Rack, Bobbin Winder and Stool. Excellent condition. £25 o.n.o.
Apply:- Mrs. Rose, 37 Wootton Road, Finchfield. Wolverhampton.

FOR SALE. Dryad "WENDYCOTE" Loom. 15" width. 4 shafts. Wire healds. 14 dent reed. Good condition. £4.10.0.
Apply:- Mrs. Green, Oak Bank, Fordwater Road, Chichester, Sussex.

FOR SALE. "DOUGLAS ANDREW" Hide-away Loom. 4 shafts. Excellent condition but space needed. Part carriage paid in Great Britain. £12.
Apply:- Blake, 29 Windermere Road, Gloucester.

FOR SALE. "MAXWELL" Loom 38" 4 shaft 6 pedal. Very good condition. £18.
Apply:- Mrs. Keand, 5 Silverhill Cottages, Hurst Green, Etchingham.Sx.

FOR SALE. "DOUGLAS ANDREW" Canterbury 4 shaft Foot Loom. 32". £15. o.n.o. also, London School of Weaving Table Loom 4 shaft, side levers 24". £12.
Apply:- Miss Kathleen M. Blair, Monk's House, Seahouses. Northumberland. Tele. 372.

FOR SALE. "DRYAD" Warping Mill. Folds flat when not in use. Up to 50 yard lay. £7.10.0.
Apply:- Miss Woodward, "Elibank", Bolts Hill, Chartham. Canterbury.

FOR SALE. 20" Secondhand 2 shaft Weavemaster Table Loom. 14 dent reed. Perfect condition. £3.

12" Secondhand Easymaster 2 shaft Table Loom. 3 dent reed. Wire healds. Good condition. 30/-

Kemar Rigid Heddle Loom. Completely new. 30/-

Dryad Inkle Loom. Perfect condition. £2.10.0.
Apply:- Cathedral Weaving Centre, 57, Castle Street, Canterbury.

LOOMCRAFT

Single copy 1/3d., post free.

5/- per year inc.post.

BY WEAVERS—FOR WEAVERS—ABOUT WEAVERS

Volume Three.

JANUARY 1964

Number 8.



Editorial.
Further Tweed Pattern.
Colonial Overshot.
A Cotton Dress.
Huck-weaving With
Sample.
Handweaving In
Therapy.
A Tablecloth in Checks
& Lace.
New Yarns.
May We Remind You...
Illustrations.

"LOOMCRAFT" is issued
Jan. April, July & Oct.

57, CASTLE STREET, CANTERBURY, KENT.

Telephone. Canterbury 3935.

57, Castle Street,
CANTERBURY.
Kent.

January 1964.

Dear Friends,

Another New Year, and I expect we are all making resolutions to do more and more weaving! Judging from the first few days of this month quite a number of our customers have already started to put this into operation. Now with a new "LOOMCRAFT" I hope it will spur even more of our friends on to try out some of the ideas we have for you.

We must first of all apologise for the slight delay with the day of despatch, but it has proved something of a problem to make good our promise to make the back page into our illustration gallery. Please do bear with us if you do not think it is as good as you had hoped - we shall improve as the issues come along!

With the coming of the illustrations on the back page we have now put the Sales and Wants on the insert sheet. We feel that this is a good move as it also carries the current Special Offer list as well. This, of course, changes each month, so if it should get mislaid it will not matter as both these items soon go out of date.

Also on the insert page we shall try and give you a quick glance of some of the Standard lines which we have suggested for the various weaving projects we are offering from time to time. This also will not matter if it gets lost.

We should like to take this opportunity to send our warmest greetings for the New Year. This comes from all our staff, including our latest addition - Bill Beiler, the cat!

Sincerely yours,

(Mrs)Margaret A.Norris.

A FURTHER TWEED PATTERN.

So many readers have enjoyed the Tweed articles that I am prompted to give you yet another one, so I thought that a twill with a difference would appeal.

We used Scottish Tweed yarn for it and single sleyed a fourteen dent reed. Also, the warp ends were single through the healds. Allow 9/10 ozs of yarn per yard, sett at 32" width in the reed for the warp and weft. It would make a delightful skirt length if woven in two colours, one for the warp and another for the weft. Supposing you are preparing to weave enough for a straight skirt with a pleat at the back, then you will need 2 yards of finished material 27/28" width. For this allow 10 ounces each of two contrasting colours.

Make a warp 3 yards long by 451 ends. If you can weave very close to the castle, then you may reduce your warp by anything up to 12 inches in length, but do be sure to leave enough to weave about 2½ yards to allow for shrinkage in scouring and finishing which must be carried out before being made up.

Thread the healds singly throughout using the draft given below:-

4	4		4	4		4	4		4	4		4	4		4		4	
3	3		3	3	3	3		3		3	3		3		3		3	
2	2		2	2	2	2		2	2	2	2		2	2		2		2
1	1		1	1	1	1		1	1	1	1		1	1		1		1

Selv.(8) Patt."B" (15 ends) Patt "A" (15 ends) Selv.(8) Shafts.

Analysis of warp ends.

Weaving lifts.

Selvage... ..	8	<u>Shafts.</u>	<u>Pedals.</u>	<u>Times.</u>
Patt. A & B (14 times)	420	4 - 1	6	1
Patt. A (once).	15	1 - 2	1	1
Selvage... ..	8	2 - 3	2	1
		3 - 4	5	1
	<u>451</u>			

Repeat throughout length.

Just use up any odd inches of warp you may have left after the 2½ yds to try out other lifts - I am sure you will find other designs resulting from this draft which will please you just as much as this one.

We can finish the tweed for you if you wish. It will cost 1/9d., per yard or part of a yard, plus return pack and post. Please allow 14 days for this service.

All tweed is woven in oil, therefore the cloth must be scoured and shrunk before being tailored.

ADVANCED PATTERN OF COLONIAL OVERSHOT.

So many friends have remarked upon three cushion covers we have on the settee in our sittingroom, that I feel you may like to consider something on the same lines. They are on a 12/2's mercerised cotton warp with the same kind of thread for the binder but each cushion has a different colour pattern thread; one is Scarlet, another Gold and the third is Emerald. All in 4 fold Rayon Crepe Twist, and even after ten years wear and several hand washings, they still look as fresh as when they were new.

The finished size is 20" square and I propose to give you the details for making them just as I did. If you wish to modify them to your special needs, then I feel sure that you will be able to do this to suit your purpose. You will need 1.1b of Black 12/2's mercerised cotton for the warp and weft binder, and each cushion cover needed $6\frac{1}{2}$ ozs of Rayon Crepe Twist.

A fourteen dent reed was used and this was double sleyed to give 28 e.p.i. All threads were single in the healds throughout. Lay a warp of 607 ends by $4\frac{1}{2}$ yards long and thread pattern as given. This will be $21\frac{3}{4}$ inches approx. in the reed.

Commence weaving, after testing for crossed warp threads etc., by making a 2" plain weave heading with 12/2's cotton. Now follow the lifts given and work one cover. Finish off with 1" plain weave strip and then with a coloured thread weave 2 rows to mark the cutting line to guide you when dividing the covers ready to make them up.

Weave the second and third covers in the same manner except that the Rayon Crepe Twist pattern thread is changed to a different colour for each cover.

When finished and divided up, the 2" of plain weave is doubled over to give an approximate 1" "lip", and the 1" strip at the other end is folded on to the wrong side of the weaving and neatly slip-stitched down. The sides should be carefully matched and oversewn, leaving just the "lip" at one side. When the cushion or pad is in position in the cover, this lip is tucked in and the pattern is matched up along the two edges and slip-stitched to close it.

Care must be taken to keep an even beat so that the patterns will match up at the sides. It may be that you do not wish to use Rayon Crepe Twist, in which case, perhaps 6/2's mercerised cotton or a Lyscordet will have the colours you need. For 6/2's cotton I think you will need a little over 4oz of each colour, and with Lyscordet it will break into the sixth ounce for each colour.

We can supply Rayon Crepe Twist in Gold, Yellow, Scarlet, Emerald, Reseda Green, Pale Blue, Deep Blue, White, Peach and Rose. For 6/2's and Lyscordet colours please send a stamped addressed envelope stating the yarns in which you are interested and we shall be happy to forward samples of these for your selection.

COLONIAL OVERSHOT (contd.,)

The Weaving Lifts.

<u>Shafts.</u>	<u>Times.</u>		<u>Shafts.</u>	<u>Times.</u>
1 & 2	1		1 & 2	4
2 & 3	1		2 & 3	4
3 & 4	1		1 & 2	2
1 & 4	1	Selvedge &	2 & 3	4
1 & 2	2	Link once.	1 & 2	4
2 & 3	4		1 & 4	6
1 & 2	4		3 & 4	6
1 & 4	4		1 & 4	4
			3 & 4	4
			1 & 4	4
3 & 4	4		3 & 4	6
2 & 3	4		1 & 4	6
1 & 2	4	Border	1 & 2	4
2 & 3	4	3 times.	2 & 3	4
3 & 4	4		1 & 2	2
1 & 4	4	⊙	2 & 3	4
			1 & 2	4

Centre Pattern.

Now use Border lifts once only.
 Repeat lifts for Centre Pattern once more.
 Then working in reverse from ⊙ to beginning
 of selvedge. This gives one half of cover
 and the second side is worked exactly the same.

A binder row follows
 every pattern row.

Binder lifts are
 1 & 3, 2 & 4 alternately.

Threading for healds.

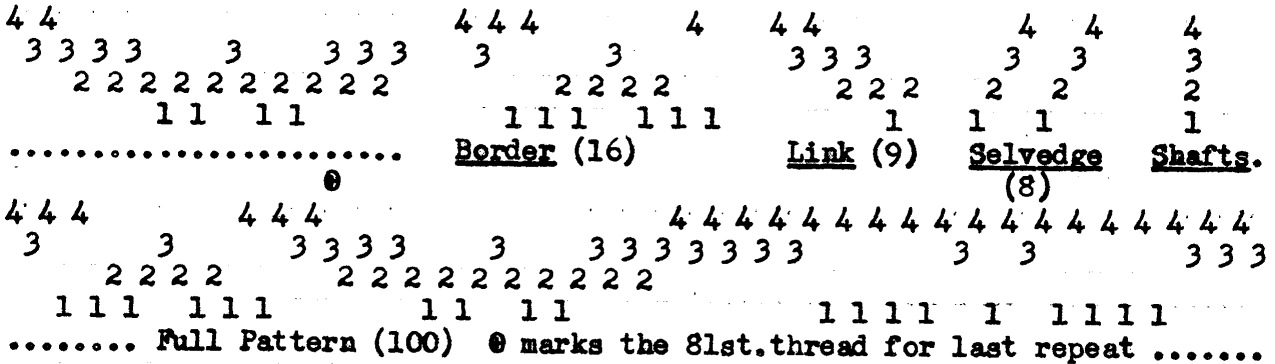

Warp thread analysis.

Selv. 8., Link 9., Borders 96.,	4	4		4 4	4		4 4 4
3 full patterns 300., 1 Part Pattern	3	3		3 3 3		3	3
to 81st. thread., 6 Borders 96.,	2	2		2 2 2		2 2 2 2	
Link 9., Selv. 8., In all 607 ends.	1	1	1			1 1 1	1 1 1
	<u>Selv.</u> (8)	<u>Link</u> (9)	<u>Border</u> (16).				

ALWAYS READ PATTERN THREADING FROM RIGHT TO LEFT.

A COTTON DRESS FROM HANDWOVEN MATERIAL.

When a reader sent in her subscription for "LOOMCRAFT" a week or so ago, she also made a request for "a copy of "Loomcraft" giving details for making a cotton dress". Well, I'm afraid I could not do this, simply because we have never given details for a dress! Cotton skirts, yes, but not even a cotton blouse, so I would like to make some comments here for a dress.

If you wish to use 12/2's mercerised cotton, allow $\frac{1}{2}$ lb yarn per square yard for warp and weft - if your pattern calls for 5 yards of 36" material, then purchase 2 $\frac{1}{2}$ lbs of yarn. For 16/2's mercerised cotton allow $\frac{6}{7}$ ounces per square yard, and so for your 5 yards of 36" material, 2lbs of yarn would be ample.

Do not ignore the offer on the Special Offer sheet enclosed in this magazine, for 20/2's cotton which could be used for this project if you can weave it close enough. In this case you will need 1 $\frac{1}{2}$ lbs of your chosen colour.

Now for some hints about settings etc., For 12/2's cotton use a fourteen dent reed double sleyed, 16/2's will need a twelve dent reed triple sleyed, failing this, use a fourteen dent reed and sley 2 & 3 alternately which will give you 35 e.p.i. If you decide to weave with 20/2's, use either a fourteen dent reed sleyed 3 per dent to give 42 e.p.i. or a twelve dent reed sleyed 4 per dent to make 48 e.p.i. if you can beat well (this depends upon your loom).

Make your calculations bearing in mind the width you can weave and the length you need, and then work out how many warp ends you need, making this as near to a multiple of 8's, so that if you thread the healds in "Rosepath" you can weave a strip at the end using another colour to cut for cuffs and collar and perhaps the belt. If you do carry out the suggestion of patterned collar and cuffs, use the same thickness cotton for the pattern.

Here I give "Rosepath" threading and a very simple pattern which may be useful to you. Remember, even with the warp threaded in pattern, by using shafts 1 & 3, 2 & 4 alternately, plain weave can be produced. When you have woven the full length, I would suggest either a very thorough steam pressing or a mild laundering before starting to make it up.

Threading for "Rosepath".

4	4	4	<u>Shafts.</u>	<u>Times.</u>	<u>Shafts.</u>	<u>Times.</u>
	3	3	3 & 4	1	3 & 4	1
	2	2	4 & 1	1	2 & 3	1
	1	1	1 & 2	1	1 & 2	1
			2 & 3	1	4 & 1	1

(8 threads repeated.) Shafts.

Repeat throughout pattern strip.

HUCK WEAVING.

Plain Huckaback weaving was featured several issues back with directions for making guest towels using cotton and linen. These proved very popular and we are still receiving orders for materials, several readers gave a number of these for presents over the Christmas just past. So, we thought something a little more advanced would be useful. With Spring cleaning only just round the corner, it might be a thought for kitchen or bathroom curtains and also bedrooms with cottage type windows.



The actual draft is quite simple and you can lay your warp to suit the width you need. This sample was sett at 28 ends per inch using 12/2's cotton double sleyed through a 14 dent reed and single in the healds throughout. One shuttle only is needed, this weaves both plain and pattern material. Allow 12/2's cotton as previously suggested; 1/2 lb per square yard of finished material.

The warp ends must have a total giving 8 ends each selvedge and then a multiple of 14 plus 5. Therefore, suppose you are weaving a width of 24" at a setting of 28 e.p.i. you would need 679 to be divided up as follows:-
Selvedge 8, 47 repeats of pattern 47 x 14 = 658, Balance of 5 once, and final Selvedge 8, giving a total of 679 in all.

The threading is as follows:-

4 4 4 4	4 4 4	4 4 4 4 4	4 4 4 4	4
		3		3
2 2 2 2	2 2	2 2 2 2 2 2	2 2 2 2	2
		1 1		1
<u>Selv.</u> (8).	<u>Bal.</u> (5).	<u>Pattern</u> (14 ends)	<u>Selv.</u> (8).	<u>Shafts.</u>
	(once)	Repeat as desired.		

Always read drafts from right to left.

The binder or plain weave is on Shafts 1 & 4, 2 & 3 alternately. Weave a heading of this to give you a hem or border whichever you need according to your requirements. Now the weaving lifts for pattern are as follows:-

<u>Part 1.</u>	<u>Part 2.</u>	Weave.	Part 1
<u>Shafts.</u>	<u>Shafts.</u>		Part 2
1 - 4)	2 - 3)		Part 1
1 - 2)	3 - 4)	Then eight rows of plain. Now	Part 2
1 - 4)	2 - 3)	weave	Part 1
1 - 2)	3 - 4)		Part 2 followed by
1 - 4)	2 - 3)		eight rows plain.

Continued on Page 8.....

HANDWEAVING IN THERAPY.

We are always happy to hear of Handweaving being used in Hospitals and Institutions, and from time to time we are requested to supply equipment and yarns for this purpose. When we started to manufacture the small table looms we little thought that they would carry the name of "LOOMCRAFT" to so many far off places. In particular we are sending them to South Africa at very regular intervals. They are being used in a home for Spastic Children, and from the reports we have from the teachers in charge, they are giving great satisfaction and help to their users. In this particular case the looms seem to be the property of the children as they are bought by the parents for their use in class. We are also sending yarns to the same Home.

About two months ago we were requested to despatch two of these looms to a School in Ceylon for Deaf Children, but in this case they were paid for by donations through Unesco. One loom was subscribed for by a school in the North of England, and the second by a troupe of Girl SCOUTS in America.

We also supply yarns to another Organization in Surrey which is for the care and employment of Chair-bound women and girls, who number amongst their occupations handweaving. They are engaged upon making tweeds, woollen scarves and stoles, and other household linens.

No doubt you have heard about the various activities of the Rudolf Steiner Homes up and down the country, and here again we are supplying many things to several of the Homes and Village Settlements. Recently we were called upon to supply two big looms and a quantity of equipment to a new Village Settlement in Berkshire. The teacher in charge of this came to visit us and so we were able to ask her lots of questions which she so readily answered. This Village Settlement is for teenage mongoloids, and from what I have heard in recent letters it is proving very successful. I have permission to quote from a letter so that you may know a little more about their weaving activities:- "Our looms are wonderful. The first one we had has already given us many yards of material woven by a mongoloid, and now a new warp has been made. The other is also in use. Another mongoloid is first threading it. It takes, of course, about three times as long as in normal cases, but that is part of the occupation. But, though slowly, he and his friend are doing well together."

HUCK WEAVING. (contd. from Page 7)

Repeat this order throughout and then the heading of plain to match the commencement. Remove from the loom, make up and then steam press or launder. We have also tried this for luncheon mats sett at 18 e.p.i. using the 4/2's mercerised cotton on the S.O. list, allowing 2 oz. per square yard. The warp was of Deep Yellow and the weft is a Warm Rust and the result was delightful. Any two strong contrasting colours would look extremely effective. It could also be woven in W.W. 6/2's mercerised cotton or Lyscordet. We do hope you will like this simple but effective draft.

A TABLECLOTH IN CHECKS AND LACE.

If you have a loom wide enough to sett at 38" you may be interested to read about the possibilities of a Linen afternoon tea cloth in two colours. You will need a fourteen dent reed which should be sleyed 2 & 1 alternately to give 21 e.p.i.

You will need 12 oz of 25/2 mercerised linen, 4 oz of one colour, whitey-brown or natural I would suggest, and 8 oz of the colour of your choice. If this does not appeal to you, substitute white for the whitey-brown or natural, but for the simplicity of this article I shall call it "W.B. & Colour". I am assuming that you can accommodate 38" on your loom and that you have a 14 dent reed. Proceed as follows:-

Lay a warp $1\frac{3}{4}$ yards long, including the threading cross, in this order:- 33 W.B. 33 Colour and 17 W.B. 15 times, finishing with 16 W.B. This will make 799 ends. These should be threaded according to the following draft.

			4 4	4 4		4 4	4 4					
3	3	3	3 3 3 3 3 3 3 3 3 3 3 3 3 3 3 3 3			3	3					3
2		2		2	2	2	2		2	2		2
					1 1	1 1						1
<u>Selv.</u>	<u>Link.</u>	<u>Last Stripe.</u>	<u>Part "B"</u> (34 ends)				<u>Part "A"</u> (16 ends)		<u>Selv.</u>	<u>Shafts.</u>		
(16)		(16 ends)	Repeat 15 times.				Repeat 8 times.		(16)	8 times.		
8 times.		8 times.										

Analysis of Warp.

Selvedge...	16	
Parts A & B (15 times)...	750	The plain weave is obtained by
Part A (once)...	16	using Shafts 1, 2 & 4, then
Link...	1	Shaft 3 only, alternately.
Selvedge...	16	
<hr/>						
<u>799 ends.</u>						

After the loom has been completely dressed and you are ready to weave, proceed according to the following lifts.

Plain weave for 33 picks, or enough to square the outer Whitey-Brown Stripe.

<u>Shafts.</u>	<u>Times.</u>		<u>Shafts.</u>	<u>Times.</u>	
3	1	}	1 & 2	1	}
2	1		3	1	
3	1	} Twice.	1 & 2	1	} Once.
2	1		3	1	
3	1	}			}
1,2 & 4	1		1,2 & 4	1	
			3	1	
3	1	}	2	1	}
1 & 2	1		3	1	
3	1	} Once.	2	1	} Twice.
1,2 & 4	1		3	1	
3	1	}			}

IN COLOUR.

NEW YARNS WHICH WE CAN OFFER.

A very good gimp has been added to our Special Offer Yarn list which I would like to bring to your notice. It is something of a large spot gimp and would be ideal for a texture weave using an ordinary cotton warp thread with it. I visualise it warped through a coarse reed in the same manner as the sample of snarl and cotton which we gave about eighteen months ago. In this way the gimp could be used in the warp as well as the weft, but it must be through a reed which will beat the web without breaking the gimp in the process. I would suggest a seven dent reed, or at the finest an eight. It comes in three colours only, Beige, Royal Blue and Bottle Green. (S.O.4).

If you are interested in the suggestion for a cotton dress and have had some experience of using fine threads, you may be interested in the new coloured 20/2's we are offering on the latest Special Offer list. It is, of course, something of a challenge to use for the first time, but there is much satisfaction when you take off a piece of weaving that does you credit. Colours are Rose, Rust, Searlet, Lime, Pink & Green. (S.O.61).

The 6/2's which we have also managed to run to earth, and are happy to offer at our usual S.O. price of 8/-, is worth considering if you do not wish to use the Four Fold Rayon Crepe Twist which I suggest as a good pattern thread for the Colonial Overshot pattern. The Blue, Yellow and Pink/White mottled would show up very well on Black, but I think that unless Green is a "must", you will be well advised to leave this for some other project as it is a little on the dark side and would look best on a lighter coloured warp. The Rose Pink is very charming, but I must warn you that there is not much of this, so do order all you need in case it is soon taken and you will not be disappointed. Remember, we cannot promise any more when these stocks are exhausted. (S.O.62)

Some time ago we offered some 4/2's in mercerised cotton which is the same as Lyscordet, but we were only able to obtain three colours. These were Rust, Beige and Orange. Although they were more than we like to offer our bulk purchases at, they were not dear at 12/- per pound, considering that Lyscordet is now 1/5d., per ounce, so do try the Muck pattern in this. (S.O.54)

A Tablecloth in Checks and Lace (contd.,)

Now weave 17 picks of Whitey-brown in plain weave. Continue in this manner until you have woven a yard, then 33 picks of Whitey-brown to match wider stripe at commencement. Remove from loom, make neat small hem all round and steam press. This can of course be woven in 6/2's mercerised cotton using the same setting but it will break into 1½lbs, of cotton.

Another good idea would be to weave serviettes to match. This can be achieved by making a wide Whitey-brown stripe down the middle of the warp. I would suggest 66 ends and then the same wide stripe of weft half way through. This would then form the hems of the four serviettes which would be approximately 17 inches square. I hope this will appeal to you.

"MAY WE REMIND YOU....."

When we first launched "LOOMCRAFT" eight years ago, we sent receipts for the subscriptions as we received them, but we soon found that the time, stationery and postage were so prohibitive that it was reluctantly ceased. From time to time we have published a reminder of this, but of late several readers have written in to enquire for acknowledgement of their subscriptions. Will you please note, therefore, that unless orders for yarns are also sent we cannot send a receipt. We will, of course, send this to you if a stamped and self-addressed envelope is included. We are doing all possible to keep the price of "LOOMCRAFT" as low as we can, and the price of the large envelopes has just risen again!

You will, I hope, appreciate that primarily the object of this craft magazine is to offer you the yarns most suitable for weaving the various articles given each quarter. Even so, keeping down our overheads to a minimum, quite a number of our readers never appear in the order books - either they are using up yarns accumulated over years, a very commendable act, or the yarns we offer do not appeal to these weavers; for this I am sorry and can only hope that sooner or later we can remedy this!

May we ask you not to remit stamps for small amounts. It upsets our book-keeping arrangements and must, therefore, ask you not to do this. We draw enough for postage charges each week and these odd amounts throw us out as Banks do not accept stamps on paying-in slips. Please bear this in mind.

Postal charges, over which we do not have any jurisdiction, seem to cause some customers a certain amount of confusion; this need not be so if you will bear in mind that pack and post on one pound is 1/9d., up to 2lb, including paper for packing is 2/3d., and then upwards add 3d., per pound. Do remember that if you order 3lbs of yarn, the postage on this is 2/6d. plus 3d. for packing etc., - the paper etc., must take the yarns over the 3lbs mark and then they are classed as "under 4lbs weight". Thank you!

FOR YOUR CONVENIENCE.

Postal Charges plus packing.

Parcels not over 2lbs...	2/- + 3d. pack.	Parcels not over 10lbs...	4/- + 3d.,
" " " 3lbs...	2/3 + 3d. "	" " " 12lbs...	4/6 + 3d.,
" " " 4lbs...	2/6 + 3d. "	" " " 15lbs...	5/- + 3d.,
" " " 5lbs...	2/9 + 3d. "	" " " 18lbs...	5/9 + 3d.,
" " " 6lbs...	3/- + 3d. "	" " " 22lbs...	6/6 + 3d.,
" " " 8lbs...	3/6 + 3d. "		

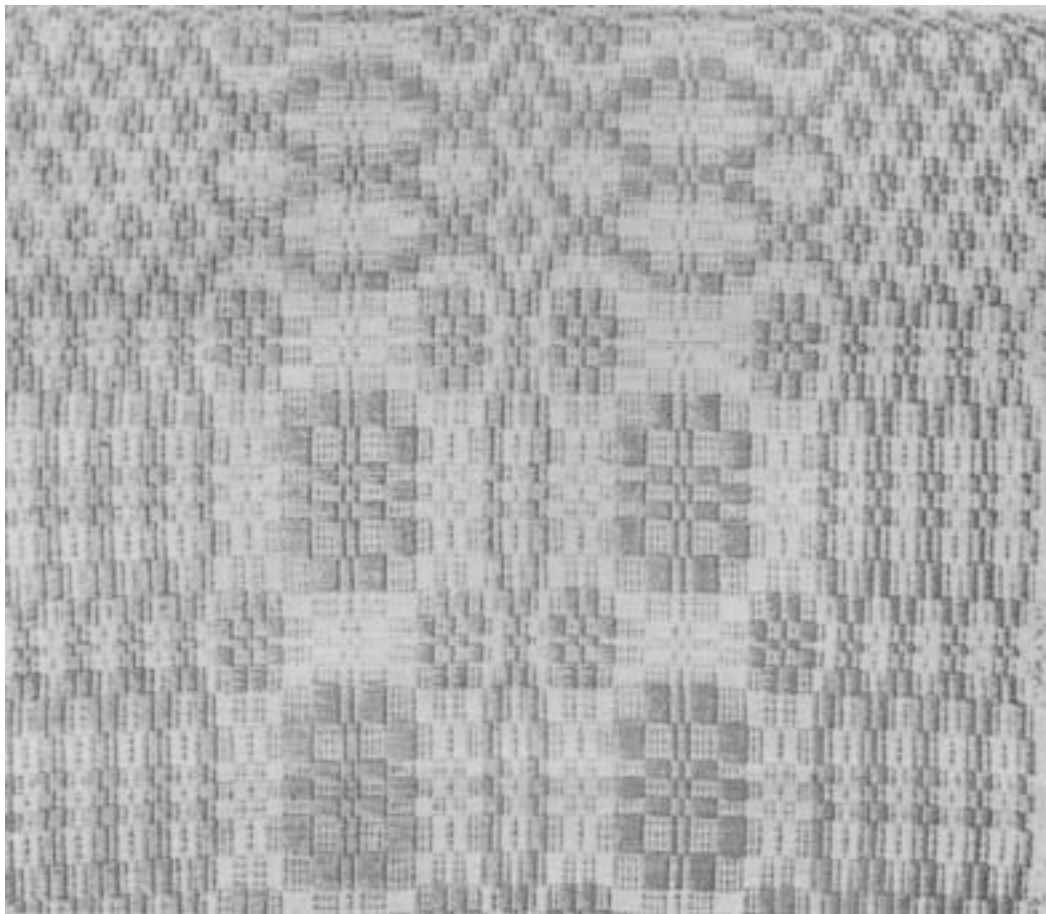

COLONIAL OVERSNOT PATTERN. PAGE 4.

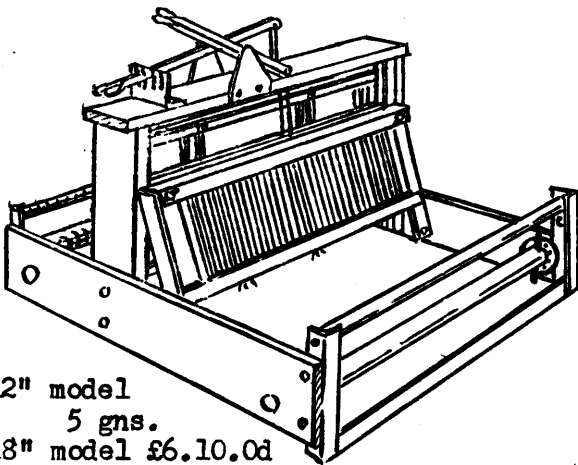

12" model
5 gns.
18" model £6.10.0d

"PALACE" 4 SHAFT TABLE LOOM.

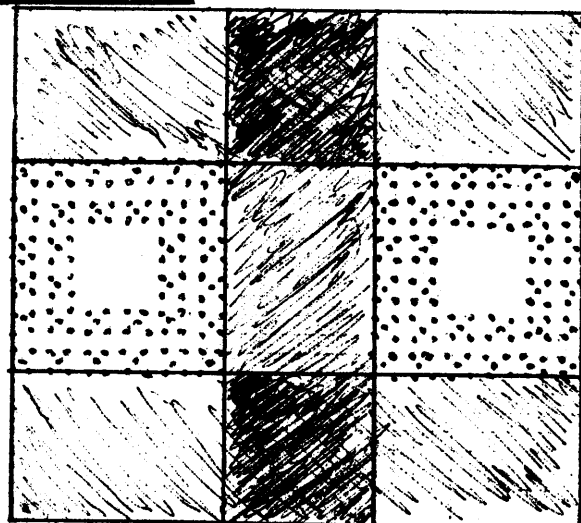

CHECKS AND LACE. PAGE 9.

LOOMCRAFT

Single copy 1/3d., post free.

5/- per year inc.post.

BY WEAVERS—FOR WEAVERS—ABOUT WEAVERS

Volume Three.

APRIL 1964

Number 9.



Editorial.
Another Tweed Pattern.
Colonial Overshot.
Rya Rugs.
Texture Weaving again.
Huck Diamond
 With Sample.
Padded Tea Cosy.
Tuition with Holidays.
Gay Beach Bag.
Check Summer Skirt.
Illustrations.

"LOOMCRAFT" is issued
Jan. April, July & Oct.

57, CASTLE STREET, CANTERBURY, KENT.

Telephone No. 63935.

57, Castle Street,
CANTERBURY, Kent.

April 1964.

Dear Readers,

We hope that once again we have managed to find plenty of weaving suggestions for this issue of "LOOMCRAFT", and that the looms will soon be working at full capacity once more!

When it comes to the final selection of ideas we want to pass on to you, it is always something of a conflict to know which we should use and which we should "put away for another time". Sometimes we get a last minute request for details of something which we think will be of interest to quite a number of readers, and then panic sets in to be sure we do not rush it and give some incorrect instructions! So now you can imagine what it is like here when "LOOMCRAFT" times comes round!

As this number will coincide with the end of Spring cleaning activities, we hope that you will find new ideas for covers, curtains and cushion covers etc., which will appeal to you and make you want to weave them. Although the Summer seems a long way off, we are sure that the Beach Bag sent in by Miss Scarfe of Guernsey will please you. It may be that you will weave several and find a ready sale for them - I know that is what Miss Scarfe is doing.

With the prospects of the Summer holidays in sight we look forward to renewing old friendships and making new ones with the many weavers who will be in this part of the country. So do pop in and have a look at our stocks, this will give you a better idea of what we can offer than all the lists we may issue. Also, do remember that we do not charge more for small amounts; our prices are based on one pounds which are then broken down into halves and quarters for the weavers who cannot always accommodate the larger quantities.

One last word; we have had an addition to our telephone number, so if you need to ring us at any time please note that it is now Canterbury 63935.

Happy weaving to you all,

Sincerely yours,

(Mrs.) Margaret A. Norris.

ANOTHER TWEED PATTERN IN TWO COLOURS.

The tweed patterns we have been giving during the last eighteen months have proved so popular that once more we offer yet another which may appeal to you. This, unfortunately cannot be illustrated as we do not have the time to weave another sample, but the overall effect is something of a zig-zag, and I am sure that if you like a tiny check in an unusual pattern, this will appeal to you just as much as the others we have offered.

Although the Autumn seems a long way off it may be a thought to suggest that a dress length in Shetland 21 cut tweed yarn would be a good idea. The project need not be rushed, and there is also ample time to have the tweed scoured and finished so that it is ready for making up.

The best setting for this fine tweed yarn is 24 to 28 e.p.i., and sett at 24 e.p.i. we find that it takes 5 ozs per yard of material threaded 32" in the reed, which gives a finished width of 28" when off the loom and scoured and finished professionally.

The pattern calls for two colours and the proportions are 3/5ths of a light shade and 2/5ths of a dark shade. So work out the length you will need and then allow 5 ozs for each yard as suggested above. Now divide this into the 2/5ths and 3/5ths for the two colours you have chosen. If you are going to use the closer setting of 28 e.p.i., then about $\frac{1}{2}$ oz extra for each yard should be added to your calculations to be on the safe side.

The threading is plain 1, 2, 3, 4 repeat throughout, and the weaving lifts are those used to produce twill, but I will give these later on.

Threading Draft.

D D L L L

L D D L L

L L D D L

L L L D D

"D" represents the Dark shade.

"L" represents the Light shade.

20 ends. Repeat throughout. Same proportion for weft as for warp.

All warp ends are threaded singly through the healds, but if you use a 12 or 14 dent reed, they are sleyed double through the dents.

Weaving lifts are as follows:- shafts 1 & 2., shafts 2 & 3., shafts 3 & 4., shafts 4 & 1., repeat throughout. Foot loom weavers use standard tie-up.

This pattern and combination of colours could also be used with cottons; 12/2's for instance would produce a delightful texture if sett at 28 e.p.i., and 6/2's sett at 20 e.p.i., would give a thicker material for late Summer wear.

We can undertake to scour and finish your woven cloth for you at a reasonable figure of 1/9d., per yard, plus the return postage. Please allow 10/14 days for this service.

ANOTHER COLONIAL OVERSHOT PATTERN.

This has always been a firm favourite with me, and I have used it for a number of projects from table mats to bedspreads and it always looks good. It has several names, but I think that its prettiest is "Snail's Trail and Pussy Cat's Paws." I suppose that as I am so fond of cats and as a child the sight of a snail with it's house on its back caused great interest at all times, this is not to be wondered at. When small children are in the showroom and I tell them the name, it seldom fails to promote enthusiasm in not only the children but in the adults too.

I have graphed this setting for you and, as with the last number of "LOOMCRAFT", I am giving instructions for its use in conjunction with cushion covers, but if you study the breakdown of the warp ends you will quickly see how you can use it for other projects - it simply means cutting out pattern repeats to reduce its width, or adding more to give a wider finished material.

Once more I suggest that one of the best yarns for the warp is 12/2's cotton, either in colour or unbleached. The same count yarn should be used for the binder thread, and pattern thread can be 6/2's mercerised cotton or Rayon Crepe Twist. For a cushion cover approximately 20" square you should allow 4/5ozs of 12/2's cotton and 6ozs of 6/2's cotton or 7ozs of Rayon Crepe.

This should be sett at 28 e.p.i. and I find that the best reed to use is a 14 dent one which should be sleyed double to give 28 threads to the inch. It is more economical to weave more than one at a time, so if you propose to do so, add 2 more feet to the length of warp for every one. For just one cover lay a warp of 603 ends 1 1/4 yards long. This is then sleyed double in the 14 dent reed, and single through the healds,

Threading Draft.

	3 3 3 3 3	3 3 3 3 3	4 4 4	4	4
			3 3 3	3	3
2 2			2 2 2	2	2
1 1 1 1	1 1	1 1 1 1	1 1	1	1
84 threads.....			<u>Border No.1.</u> 12 ends.	<u>Selv.</u> (twice)	<u>Shafts.</u>
4	4 4 4		4 4		
3	3 3 3		3 3 3 3 3	3 3 3 3 3	
2	2 2 2				
1	1	1 1	1	1 1 1 1	1 1
<u>Selv.</u> (twice)	<u>Border No.2.</u> (12 ends)	<u>Link</u>			<u>Pattern..</u>

To obtain a balanced pattern I have given enough warp ends to allow for the Pussy's Paws to appear four times across the width of weaving. So do carefully study the analysis of warp threads before you embark upon the actual threading of the healds. Regarding the last thread of the "pattern"; this is to be included with each repeat except the last, as this "No.1" appears as the first thread of the border.

COLONIAL OVERSHOT. (contd.,)

<u>Warp Threads Analysis.</u>	Selvedge.	8
	Border No.1. 6 repeats of 12 threads.	72
	Pattern. Patt., 3 borders, Patt., 3 borders, Patt., 3 borders.	360
	Pattern less the link.	83
	Border No.2. 6 repeats of 12 threads.	72
	Selvedge.	8
		<u>603</u> ends.

After all the threading and sleying has been completed, weave one inch of plain weave using shafts 1 and 3, and 2 and 4 alternately. This is with the 12/2's yarn which is also used for the binder threads that follow each pattern row. Now proceed weaving the pattern as follows, but remember to watch that the Paws are square as far as you can by either reducing the repeats or adding.

<u>Weaving Instructions.</u>	<u>Shafts.</u>	<u>Times.</u>	
For foot loom weavers	1 & 2	8) Pattern.
the standard tie-up	2 & 3	8	
applies, and will be	1 & 2	4	
found in other articles	2 & 3	8	
in this issue.	1 & 2	8	
	4 & 1	8	
	4 & 3	8	
	4 & 1	4	
	4 & 3	8	
	4 & 1	8	

Weave in this order:- Border 6 repeats; Pattern; Border 3 repeats; Pattern; Border 3 repeats; Pattern; Border 3 repeats; Pattern; Border 6 repeats.

If you are proposing to pattern both sides of the cushion cover, then repeat these instructions once more, but the beating must be uniform so that when making up the fold will come between the 6th and 7th working of the border repeats. Finish off with 1½ to 2 inches of plain weave with 12/2's which when folded will make the lip to fit into the cover, under the hem at the other side to take the press studs if fitted, or to allow for something to slip-stitch to if the opening is lightly sewn up. A plain back can, of course, be woven if preferred.



RYA RUG WEAVERS PLEASE NOTE. We have just obtained a quantity of Egyptian unbleached plain cotton in 9/4's count and this is most suitable for the finer rug warps, and together with the Worsted Carpet Thrums which we have in stock would be a very fine combination for this kind of work. I am very anxious to try one for myself but cannot seem to get sufficient time to settle down to the pleasant task I am sure it would prove to be. For those weavers who have not yet tried this, the warp should be sett at about 12 e.p.i., and the wool used for the knotting should be longer than that used for the ordinary pile rugs.

AN INTERESTING TEXTURE WEAVE.

If you are a good, even weaver you may appreciate this pattern for weaving a bedspread in sections on a fairly narrow loom. I think it will look best with a medium to dark warp of 6/2's cotton and a thick weaving cotton on a light shade for the weft.

As in the Tea Cosy pattern I will give the lifts in shafts, but for foot loom weavers I would suggest the following slight alterations to the standard tie-up of the pedals. Reading from the right, leave pedals 1 and 2 as they are with shafts 1 & 2 to pedal 1, and shafts 2 & 3 to pedal 2. Now with the two middle pedals tie shaft 1 only to pedal 3 and shaft 4 only to pedal 4. The remaining two pedals take the usual tie-up of shafts 3 & 4 to pedal 5, and shafts 4 & 1 to pedal 6. In this way you can use the two middle pedals with the others where needed to obtain three shafts in use at one ~~pick~~.

This weave needs a firm base, so I suggest that you thread at least 20 threads per inch. The pattern repeat needs 16 ends, so work out your width bearing this in mind, plus 9 extra for the selvages as I have given them in the draft threading.

4	4 4	4 4	4	4
3	3 3 3	3 3 3	3	3
2	2	2 2	2	2
1	1	1	1 1	1
<u>Selvage.</u>	<u>Pattern repeat</u>	<u>Selvage.</u>	<u>Shafts.</u>	
(4 ends)	(16 ends)	(5 ends)		

The weaving lifts are fourteen in number, but you will soon see the pattern sequence, and no doubt it will easily be followed without much reference to the instructions after a few patterns. Each lift is used once only, and the whole is repeated throughout for the length required.

<u>Shafts.</u>	<u>Shafts.(contd.,)</u>	<u>Shafts.(contd.,)</u>
2 & 3	3 & 4	2, 3 & 4
1 only.	2 & 3	3 & 4
1 & 4	1 & 2	1 & 4
3 & 4	2 & 3	1 only
2, 3 & 4	3 & 4	Repeat for length required.

Going back to my opening remarks about the weft yarn, why not use the Snarl offered on the Special Offer List, or even the Terylene Tops which should be split into either 2 or 3 pieces and lightly spun on a spinning wheel to give a more corded effect. There are so many things which could suggest themselves, even thin cotton remnants, but here again they need a light spinning to give a better finish. I cannot, of course, give you any quantity figures for how much you will need in these various textures, but for the 6/2's warp you can estimate an approximate figure by remembering that 2,500 yards goes to the pound.

HUCK DIAMOND IN TWO COLOURS.



The Huck pattern we gave in last quarter's "LOOMCRAFT" proved very popular, and many of our readers have settled upon a weaving project which takes in that pattern. Mostly the trend is for curtains, but I have heard of weavers who are going to use the draft and weaving lifts for fine woollen stoles. I am always delighted to hear about other weavers ideas with the various pattern drafts we offer. So, here is another draft on the same lines, but I think that employed as we have used it with two colours in a 6/2's cotton, it will be a good fabric for upholstery cloth so long as the beating is firm and even. I hope, however, that I shall hear of other uses which this pattern prompts in other folk.

Again it is fairly simple to sett, and the actual weaving is so easy once the rhythm is mastered. The sample was sett at 14 e.p.i., but this was done to give the Lime weft a chance to predominate. If you wish to give a more equal chance to the two colours, then sett at 16 e.p.i. For the rest of this article I shall work on the setting of the sample.

The pattern takes fourteen threads for each repeat after the first part has been threaded and should be sett as follows:-

Threading Draft.

3		4 4 4	4	4
2	2 2 2 2	3 3	3	3
1	1 1 1 1 1		2	2
<u>Selv.</u> (3)	<u>Part 2</u> (9)	<u>Part 1</u> (5)	<u>Selv.</u> (4)	<u>Shafts.</u>

Thread the selvedge (4) then parts 1 & 2 as many times as the width you intend to weave, then balance with part 1 only, and finish with the last selvedge of three ends as given.

For the pattern lifts the following instructions are given in shafts only, but as explained in other articles, the foot loom weaver should have the standard tie-up and work accordingly. Each lift is used once only.

<u>Section "A"</u>	<u>Section "B"</u>	<u>Section "C"</u>	<u>Section "D"</u>
Shafts 2 & 4	Shafts 1 & 3	Shafts 1 & 3	Shafts 2 & 4
2 & 3	1 & 4	2 & 3	1 & 4
2 & 4	1 & 3	1 & 3	2 & 4

To produce this pattern weave: A.B.A.C.D.C. Repeat throughout for length required. NO BINDER ROWS IN THIS PATTERN. One shuttle only.

The sample piece took approximately 10 oz. per square yard of 6/2's cotton, but this does not include the extra for warp tie-on and wastage, so add 2/3 ozs. according to how much you take for this purpose.

A PADDED TEA COSY IN DOUBLE WEAVE ON A FOUR SHAFT LOOM.

Do you like to make useful articles for your home, or to give as gifts which are in the novelty class and at the same time practical? If you do, then you will be interested in this Tea Cosy which is padded as you weave it, and when soiled can be washed without the irksome task of removing the padded lining first - and then putting it back afterwards!

I set up a loom with 12/3's plain warp cotton, but if you have it by you 6/2's cotton can also be used. I laid a warp to give me 24 e.p.i., and I made it just over 1 yard long. Now this is something of a waste, so if you have a Sale of Work coming along fairly soon, or a birthday present, then put on another 18 inches and this will provide enough warp and waste for two Tea Cosies. I allowed a width of 12 inches on the loom, but this drew in slightly with the weaving and padding. My warp was 290 ends, and I used a 12 dent reed, double sleyed, but an eight dent triple sleyed would serve the same purpose.

The healds were threaded single throughout, and the order was for plain weaving, vis. 1, 2, 3, 4 repeated for the width. I used a foot loom with the standard tie-up, except that pedal 2 had only one shaft connected to it through the lamms, namely shaft 2, and pedal 6 only had shaft 4 attached to it. So starting from the right side, pedal 1 was connected to shafts 1 & 2, pedal 2 to shaft 2 only, pedal 3 to shafts 1 & 3, pedal 4 to shafts 2 & 4, pedal 5 to shafts 3 & 4, and pedal 6 to shaft 4 only. In this way I was able to use pedals 1 & 6 together to give me shafts 1, 2 and 4 for one lift and pedals 2 & 5 together to give a lift of shafts 2, 3 and 4, and still have single lifts for shafts 2 and 4 when I needed them. Also, with pedals 3 and 4 tie-up to give plain weave, I had all I needed for this project.

For weavers using table looms the lifts are given in full, and should not present any difficulty. I have set them all out and foot loom weavers will quickly see the connections between shafts and the pedals that should be used.

We have now tied up and tensioned the warp, and we are all ready to be "off". First of all weave about one inch with plain weave, using shafts 1 and 3 and 2 and 4 alternately. This is to give something to beat against and also for the padding to build up to.

For the weft I used the Green Rayon Slub, but anything of the 6/2's texture will give a good result. Using each lift ONCE ONLY, proceed as follows:- Shaft 4., Shafts 2, 3 and 4, Shaft 2., Shafts 1, 2 and 4., repeat throughout for weaving. After you have woven 12 picks of these lifts which should be well beaten, raise shafts 2 and 4, this is to give the middle opening. Now cut off a length of Terylene Top, just a little longer than the width of the weaving, tuck this in the shed and beat it down with the batten, but do not make a pick of weaving. Now start again on the lifts given and weave another 12 picks, or as much as it takes to cover the Terylene

PADDED TEA COSY. (contd., from opposite page.)

Tops. Every so often you can put two lengths in at one time. Continue in this way until you have enough for one side of the Tea Cosy; I found that I needed $8\frac{1}{2}$ inches, and this took 2 ozs of Terylene Tops to pad it.

Now it is necessary to close the top and weave the second half. Raise shaft 4 and make a pick, raise shafts 1 and 3 and make a pick, this will be a little close in the actual shed, so take care when beating it down. Now raise shaft 2 and make a pick, then raise shafts 2 and 4 and make a further pick. Resume the usual order of weaving and complete another piece to match the first side.

After this, weave a plain piece to match up with the beginning. Now repeat the whole operation again if you are making two or more on the same warp. Cut the weaving from the loom and prepare to make up. As the padding is loose in the two pieces of weaving, I suggest that it should be "anchored" to keep it in place for washing purposes. Either English quilting in a fairly simple pattern, French knots at random over the surface, or some machine sewing for quickness. I used the sewing machine and made squares of approximately 2 inches all over.

Now join up the sides and turn up the pieces of plain weaving to make a hem on the side you have made the inside. To finish off the Cosy, either make a cord or buy enough to go up the sides and along the top with loops at the corners. I am sure you will be delighted with your novelty.

For one Tea Cosy you will need 4 ozs of Terylene Tops, 4 ozs of 12/2's warp or 6/2's warp, and 4 ozs of yarn for the weft. In the cottons etc., which I used, the Cosy, exclusive of cord, cost 5/6d.,

Other methods of using the Terylene Tops for padding with double weave will occur to you I am sure. What about Cot and Pram Covers?

-o-o-o-o-o-o-o-o-o-

COMBINING TUITION WITH HOLIDAYS IN THE SOUTHEAST.

With the holiday season coming along, quite a number of our readers are thinking about where to go and what to do. Each year we have students who are either staying on the North Kent Coast and coming into Canterbury each morning for a short course of weaving instruction, or they stay in Canterbury and use the Summer evenings to explore the City after spending five hours with us learning some of the weaving which they either have not tried before or find they are not too sure about. We are always happy to advise upon any problem that you consult us about, and also we can recommend a good Guest House, providing you do not leave your enquiries too late!

It always gives us pleasure to meet the various folk who do this kind of thing, and we positively glow when we get letters which say, "How often I have blessed you, (in the right way, not swearing,) when I sett up the loom in the way you showed me - by myself and always find I get a good shed."

GAY BEACH BAGS.

We received a very nice Beach Bag from one of our readers, and I have asked her to give us the details of the weaving and finish as I am sure that it will be very attractive to many weavers wanting ideas for something gay to use on holiday. So here are the instructions as submitted by Miss Scarfe of St. Peter Port, Guernsey, to whom we have sent a voucher for 10/6d., which can be exchanged for yarns etc.,

Warp a good $4\frac{1}{2}$ yards of 6/2's allowing 14 threads per inch and 18" wide. This calls for 256 ends, so that as the pattern is to be threaded in Rosepath, this number will give 31 repeats of the pattern and 4 for each selvedge.

The warp ends are single through the healds and the dents of a fourteen dent reed, apart from the first and last two which are double sleyed, are threaded singly. For the new readers the Rosepath threading is as follows:-

Pattern Threading.

4	4 4	4	4
3	3 3	3	3
2	2 2	2	2
1	1 1	1	1
<u>Selv. (4)</u>	<u>Pattern (8)</u>	<u>Selv. (4)</u>	<u>Shafts.</u>

Thread 31 times.

When all the threading, sleying and tie-up is complete weave as follows. Leave $1\frac{1}{2}$ " for the fringe, then weave 3" in plain weave using shafts 1 & 3 and 2 & 4 alternately. Now four different Rosepath lifts are used to give bands of colour.

<u>Pattern Band No.1.</u>	<u>Pattern Band No.2.</u>	<u>Pattern Band No.3.</u>	<u>Pattern Band No.4.</u>
<u>Shafts. Times.</u>	<u>Shafts. Times.</u>	<u>Shafts. Times.</u>	<u>Shafts. Times.</u>
2 & 3 2	3 & 4 1	3 & 4 1	3 & 4 3
1 & 2 2	1 & 4 1	1 & 4 1	1 & 4 3
1 & 4 6	1 & 2 1	1 & 2 1	1 & 2 3
1 & 2 2	2 & 3 1	3 & 4 3	3 & 4 4
2 & 3 2	1 & 2 1	1 & 2 1	1 & 2 3
In Yellow.	1 & 4 1	1 & 4 1	1 & 4 3
	3 & 4 1	3 & 4 1	3 & 4 3
	2 & 3 1		
	Repeat these lifts once more.	Repeat these lifts once more.	In Pale Mauve.
	In Pale Blue.	In Turquoise Green.	

A binder row follows every pattern row, and a fine machine cotton was used for this. As the base of the bag was in two fairly dark colours, (the one sent for us to see was a Royal Blue warp and a Reseda Green weft, with the colours as given at the end of each pattern), the brighter colour bands stand out very well, and the binder thread of machine cotton was a dull gold. First of all the four bands were worked as given and the Nos. 3, 2 and 1 were woven again, so that the No.4 was the middle of the bag with $1\frac{1}{2}$ " of plain weave between each band. Finally, another three inches of plain weave

Continued on Page 11.....

A GAY CHECK SKIRT FOR THE SUMMER.

When we were offered some fancy yarn in Black & White it occurred to me that it would look very smart and gay if mixed with a 6/2's mercerised or plain cotton and woven into material for a skirt length.

I would suggest that the 6/2's cotton be sett at 20 or 21 e.p.i., and with 20 ends of the cotton then two ends of the fancy yarn it would give a check of about one inch if the same number of picks can be beaten into one inch of weaving. According to the width you can weave on your loom will determine the number of lengths you will need, but do make it full so that there are plenty of pleats in the waist band.

Allow 4" more in length on each piece than you need for the finished skirt, this will allow for roughly one inch to fit into the waistband, and a hem of $2\frac{1}{3}$ " with the turning. As this will be all in plain weave, there is no need for me to give a threading draft, and it can be made on either a two shaft loom or a four shaft model. We find that with a yard width for each piece of skirt there are plenty of pleats on a slim person, but even so I would aim at a minimum of 48" for the front and the same for the back. A loom weaving up to 27" width will easily produce four lengths to give this, but care must be taken to ensure that the beating is even so that the checks will match up. Weave enough extra material to give a three inch piece for the waistband which will be doubled over to take the pleats and be about 1" wide when finished.

Estimate that for a square yard you will need a little under 12 ozs of 6/2's cotton, and about 2 ozs of Black and White Fancy yarn, which is on the Special Offer list. Steam press before making up.

-o-o-o-o-o-o-o-o-

GAY BEACH BAG. (contd., from Page 10)

completes the first half. Now weave two plain rows in another colour which will guide you where to cut when making up. Weave another piece exactly as the last, but in reverse, so that you will finish with the $1\frac{1}{2}$ " left for the fringe. This warp will be enough to produce four of these Beach Bags, and with a fairly dark coloured warp it gives plenty of scope for changing the weft base and pattern colour bands. Should you decide that four are too many for your requirements, then of course you will make your warp so much shorter. Each Bag needs almost 1 yard for the two sides.

To make these bags up you will need 1 yard of buckram for stiffening and one yard of plastic to line each one. Cut the sides at the cutting line, and also through the un-woven warp for the fringes; these can be carefully machined to stop the fraying or knotted in small groups of 4 or 6 to finish off. Fix in the buckram with the bag inside and then line with the plastic, turn rightside out and secure by hand-stitching or machine stitching at the bottom. Next find some matching wools and plait a long length with a tassel at each end. Fix the tassels at the bottom corners and make a long loop up each side, securing it so that the loop at the top makes the shoulder strap.

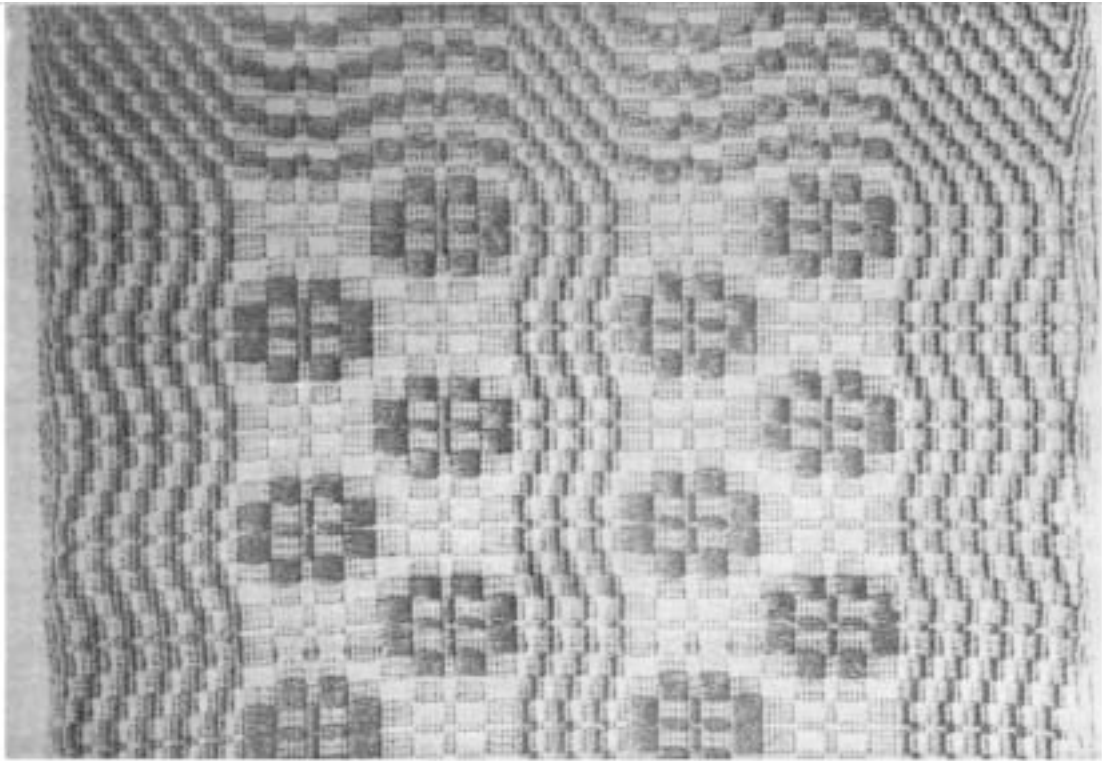

"SNAILS TRAIL & PUSSY'S PAW"



BEACH BAG

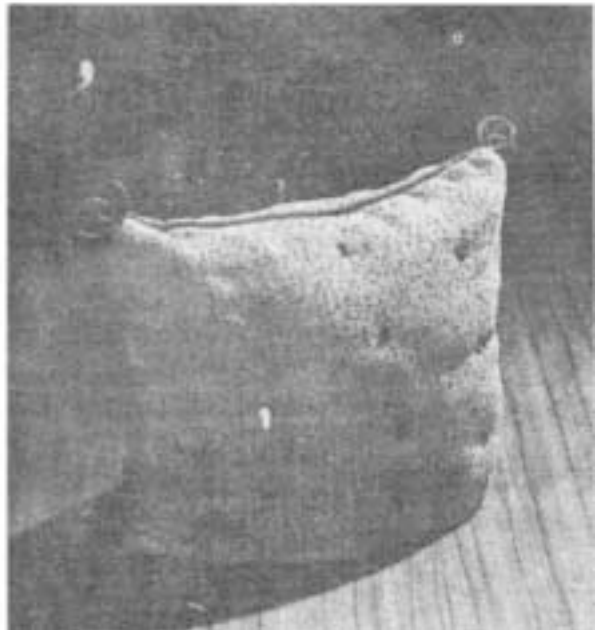

TEA COSY

LOOMCRAFT



ABOUT WEAVERS



ADVANCED OVERSHOT
PATTERN.

(Modified "Federal Knot")

Tele.No.Canterbury 63935.

57, Castle Street,
Canterbury, Kent.

July 1964

Dear Weavers,

We hope that you will approve of the new presentation of "LOOMCRAFT". For a long time we have been looking around for a printer to whom we could send the copy with the assurance that this type of finished article would be the end product. So, when we came across a small publication devoted to news and views about light railways, we made up our minds that this new size was just the thing for us.

The idea of making it into more of a book, with the illustrations at either end, seemed rather attractive and to this is added the fact that we need not fold the magazine when posting to our readers.

For the Christmas number we are getting together a good selection of small articles which will be fairly quickly and easily made, but we have tried to make a start with two items in this issue - the Shetland scarf, and the drip-mats. Why not try them out before the October number is issued?

Miss Scarfe very kindly allowed us to photograph her dress, and then sent us the brief instructions and we are very delighted to have this help and interest in our endeavours. If you have a contribution which you think we could use, please send full details, and if possible a photograph, so that we can use both for the benefit of our readers. We shall be happy to pass a credit note for 10/6d., for any article used.

Meanwhile, we hope that once the Summer Holidays are over you will start serious weaving again and that you will find much to interest you in the stocks of yarns we have just taken into stock.

Sincerely yours,

Margaret A.Norris (Mrs.,)

FOR THE NEWEST MEMBER OF THE FAMILY - A CELLULAR CARRY COT BLANKET

We have had great fun working out our latest addition to the many weaves we have in our pattern book, and judging from the interest which our personal shoppers have shown in our example, this is going to prove a winner!

It all started when an old friend of ours came back for an advanced course of weaving, and asked for something in wool weaving, "but not tweed". We knew from the numerous orders we have received from her since she purchased a "Chiltern" Foot Loom just a year ago, that tweed was not a medium upon which she needed tuition, as her order book has been fairly full with commissions of this nature. So, we decided that something which needed carefully laying and beating would be just the right exercise for her. This made us think about a weave we had been turning over in our minds some time ago, and after a little discussion we embarked upon it. The result was delightful so we agreed that our friends of "LOOMCRAFT" should be invited to enjoy it with us.

As the description may frighten some readers, we thought that a small item would be the best thing with which to get your appetites whetted! So, here we go!

It takes 7 oz of two ply Shetland wool for a Carry Cot Blanket which will measure 24 inches by 36 inches when finished. A six dent reed is used. Lay a warp about 60" long ($1\frac{3}{4}$ yards approximately) and 351 ends. All the healds are single threaded throughout, but the reed has the task of grouping the threads, and in this order:-

First eighteen dents are double sleyed; now take four threads into the next dent, one into the next and four into the following dent; now miss the next dent altogether. These four dents form one pattern and should be repeated 30 times more (123 dents) omitting the last empty dent. Now sley eighteen dents double to give the selvedge on the other side. This should give you about 26 inches width in the reed.

THREADING DRAFT (For Carry Cot Blanket)

4	4	4	4	4	4	4	4	<u>Thread Analysis.</u>	
	33	33					3	Selvedge.....	36
			22	22			2	Parts "A" and	
1	1	1	1	1	1	1	1	"B". 15 times...	270
<u>Selv.</u>	<u>Block "B".</u>	<u>Block "A".</u>	<u>Selv.</u>	<u>Shafts.</u>	<u>Part "A".....</u>				9
(18)			(18)		Selvedge.....				<u>36</u>
					Ends.....				<u>351</u>

The tension of this must be good throughout, and fairly tight to give a good, clear shed. For the pedal tie-up I used the standard one for a rising shed, but in any case you will tie the lamms to pedals to give you the four pedals in the middle of the loom so that the footwork is well under control. No true plain weave can be woven with this threading, but by using the usual tabby lifts, an interesting texture is obtained, and to match the footing this is also carried out in the selvedges throughout the pattern weaving. A good three inches of the plain weave is worked and then the pattern is obtained by using the following lifts:-

WEAVING LIFTS.

<u>Shafts.</u>	<u>Times.</u>		<u>Shafts.</u>	<u>Times.</u>		Repeat these Blocks
2 & 4	1)		1 & 3	1)		throughout, finishing
1 & 2	2)	"A"	3 & 4	2)	"B"	with Block "A" to give
2 & 4	1)		1 & 3	1)		balance.

As the middle lifts in both blocks are on the same shafts, you may do one of two things, either use two shuttles and enter from either side, retaining the second shuttle until the next double pick is reached and then changing again, or you can use the same shuttle but for the repeat pick it will be necessary to twist it round the two end threads to avoid pulling out the first pick with the second one.

Now a few words about how you should lay the picks. For the first one on shafts 2 & 4, enter this from the left, and lay it so that it leaves a gap equal to the space in the warp, now

change to shafts 1 & 2 and bring the batten down to push it carefully up to the first pick, then, if you are using two shuttles, which I found easier, change to the second shuttle and enter from the same selvedge as you have finished on with the first of the middle picks, and lay this, but after laying this one it is permissible to take the batten about two inches away from the weaving and give it just a little bump. Now using shafts 2 & 4 make the fourth pick of this pattern and again give the weaving just a slight beat. Work in the same manner for the second pattern, remembering that the gap must be left when laying the first pick of the second pattern. You will soon see a pretty basket weave emerging with fairly large spaces throughout. Be sure to keep a good firm tension and end with the three inches of plain weave to match the beginning.

Remove the weaving from the loom and steam press it. This will set the fabric which will close up slightly. Then purchase sufficient blanket ribbon to bind the work all round, and I am sure you will be very pleased with the result.

ADVANCED OVERSHOT PATTERN

This pattern, in the original draft, goes under the name of "Federal Knot", but it has been modified and you may like to give it a name of your own. This draft we are giving is designed for place mats or table runners, and when finished the width will be something like 12 inches. I would suggest that you use a fourteen dent reed double sleyed to give 28 e.p.i. and use 12/2's cotton for the warp and binder thread. For the weft it would be rather nice to use either 6/2's cotton or Lyscordet. As an alternative a coloured gimp would give a texture weave. If you are thinking of six place mats, allow $\frac{1}{2}$ lb of 12/2's cotton for warp and binder and $\frac{1}{2}$ lb of 6/2's cotton or Lyscordet for pattern weft, lay a warp of approximately $3\frac{1}{2}$ yards with 379 ends, allowing 15 inches plus one inch fringe at either end for each mat. For Foot Loom weavers the standard tie-up is recommended. For the first and last three dents of the reed sleying, it is a good idea to have three threads per dent to give a firm edge, but only one thread per heald when threading the pattern.

Threading Draft for Overshot Pattern.

```

4 4 4 4             4 4 4             4 4 4 4
  3 3 3       3 3 3             3 3       3 3             3 3
    2 2 2 2 2       2 2 2 2 2 2 2 2 2 2 2 2 2 2 2 2 2 2 2 2 2
  1 1           1 1           1 1 1 1 1       1 1       1 1 1 1 1 1 1 1
..... Part "A" 50 ends ..... Link 4 x 3
                                      Selvage 17 ends.

```

```

                4 4 4             4 4 4 4 4             4
          3 3       3 3             3 3 3       3 3 3
  2 2 2 2 2 2 2 2 2 2 2 2 2 2 2 2 2 2 2 2 2 2 2 2 2 2 2 2 2 2 2 2 2
  1 1 1 1 1 1 1 1 1 1 1 1 1 1 1 1 1 1 1 1 1 1 1 1 1 1 1 1 1 1 1 1 1
..... Part "C" 53 ends ..... 4 x 6
                                      Part "B" 24 ends

```

```

4           4 4 4             4 4       4 4 4 4 4 4 4 4 4 4 4 4 4 4 4 4
  3           3             3             3 3       3 3
    2
    1           1           1           1       1 1 1       1 1       1 1 1
4 x 3 Link           Centre 4 x 10     ..... Part "D" 25 ends.
Selvage 17 ends. Link. Part "E"

```

Warp Analysis.

Selvage.	17
Part "A" (50), Part "B", 4 x 6 (24), Part "C" (53)	127
Part "D" (25), Part "E", 4 x 10 & Link (41), Part "D" (25)	91
Part "A" (50), Part "B", 4 x 6 (24), Part "C" (53)	127
Selvage	<u>17</u>
Warp Ends..	<u><u>379</u></u>

Weave $\frac{1}{2}$ inch with the binder thread in plain weave, and remember to repeat this at the end of the mat. Also bear in mind that a pattern row is always followed by a binder row. The weaving lifts are as follows:-

<u>Pedals.</u>	<u>Shafts.</u>	<u>Times.</u>	<u>Pedals.</u>	<u>Shafts.</u>	<u>Times.</u>
1	1 & 2	4	1	1 & 2	4
6	1 & 4	4	2	2 & 3	4
5	3 & 4	4	5	3 & 4	4
2	2 & 3	4	6	1 & 4	4

contd., contd on

Weaving Lifts for Overshot Pattern (contd.)

<u>Pedals</u>	<u>Shafts</u>	<u>Times</u>		<u>Pedals</u>	<u>Shafts</u>	<u>Times</u>
1	1 & 2	8		1	1 & 2	8
2	2 & 3	4		2	2 & 3	4
1	1 & 2	4		1	1 & 2	4
2	2 & 3	4		2	2 & 3	4
1	1 & 2	8		1	1 & 2	8
6	1 & 4	4		6	1 & 4	8
5	3 & 4	4		5	3 & 4	4
2	2 & 3	4		6	1 & 4	4
1	1 & 2	4		5	3 & 4	4
2	2 & 3	4		6	1 & 4	8 \emptyset
5	3 & 4	4				
6	1 & 4	4		5	3 & 4	4
				6	1 & 4	4
1	1 & 2	4	} Four times.	5	3 & 4	4
6	1 & 4	2				
1	1 & 2	4				
						} Ten times
6	1 & 4	4				
5	3 & 4	4				
2	2 & 3	4				
1	1 & 2	4				
2	2 & 3	4				
5	3 & 4	4				
6	1 & 4	4				

This repeat brings you to the centre of the mats and you should regulate the number of repeats to give you the length of mats you require. Now work in reverse from the 8 times of shafts 1 & 4 marked \emptyset .

When all the mats are finished cut from the loom and divide through the unwoven warp which has been left for fringes, then either knot in small groups of about 4 or 6 ends, or hemstitch with some of the cotton left from the warp. Steam press and check to ensure that the fringes are even.

A little learning is a dangerous thing - be wise and have a little private tuition. Why not write to us for full particulars - we can advise you where to stay in Canterbury and there are some really delightful spots around the coast and country side which you could visit in the evenings.

GROUPED HUCK

This is our third Huck pattern and you will find it is very attractive for curtains and room dividers, as the grouping of the threads makes a very interesting fabric. Much of the ultimate beauty of this pattern must rely upon the colours you choose, so do be careful in your combinations of the yarns and textures. Since our sample was woven we have obtained a quantity of Silver Lurex of the $1/32$ " width, and also some Black and Gold Rayon yarn, both of which could be used in the weft of this pattern with a $12/2$'s cotton warp. In this case the colour must be in the warp so that the Black and Gold Rayon takes the place of the $6/2$'s used in the sample, and the thicker Silver Lurex will not swamp the cotton warp.



We used a fourteen dent reed, and with 605 ends it gave a width of approximately 24 inches on the loom, and finished up $22\frac{1}{2}$ inches wide when woven. One $\frac{1}{4}$ lb tube of $12/2$'s cotton will give you about $1\frac{1}{2}$ yards of this width, plus the wastage on the loom, so if you are making more than this width and finished length, work on these figures, remembering that only one wastage need be calculated. The weft quantities depend upon how much you beat the weaving, but in any case it is surprising how little one uses. I would estimate that a quarter pound of $6/2$'s cotton would be enough for the $1\frac{1}{2}$ yards, and $2/3$ ounces of the thicker Lurex, but even less with the finer one we used. The finer Lurex used in the sample actually has a fine black rayon thread with it, and we can offer this whilst stocks last; details are given on the price lists.

After you have laid your warp, dress the loom using the threading draft given for the healds which are threaded singly, but for the reed be careful that you group the ends in the various dents as set out below the threading draft.

When all the threading is completed, be sure that you have a very even tension and then weave about 6 or 8 picks with a length of cotton to set the warp ends. You are now ready to use the weaving lifts and I would draw your attention to these as I have

given them to fit the standard tie-up for Foot Looms as well as the lifts for Handweavers. Foot loom weavers will find that it is very simple to press down two pedals with one foot as they are next to each other with this tie-up.

Threading Draft.

4	4 4 4	4
3	3 3	3
2 2 empty	2 empty	2 2
1 dents	dents	1 1 1
<u>Selv.</u>	<u>Selvedge.</u>
(once)	1 dent	(once)
	
	One One One	
	dent dent dent	

14 dents completes one pattern.

Warp Analysis.

Selvedge	4	Thread in <u>one dent</u> all ends
42 patterns	588	marked (.....)
First 9 ends	9	
Selvedge	4	
	605	

Weaving Lifts.

<u>Part "A"</u>				<u>Part "B"</u>			
<u>Pedals</u>	<u>Shafts</u>	<u>Times</u>	<u>Yarns</u>	<u>Pedals</u>	<u>Shafts</u>	<u>Times</u>	<u>Yarns</u>
4	2 & 4	1	Lurex	4	2 & 4	1	Lurex
1 & 2	1,2,3	1	6/2's	3	1 & 3	1	Lurex
4	2 & 4	1	Lurex	4 & 5	2,3,4	1	6/2's
1 & 2	1,2,3	1	6/2's	3	1 & 3	1	Lurex
				2	2 & 3	1	6/2's
				3	1 & 3	1	Lurex

Repeat in this order throughout.

If you wish to vary your pattern from the sample, then repeat part "B", but only use part "A" once in each pattern. When off the loom steam press the fabric to set the weave. We do hope that you will like this weave, but remember that there is a right and wrong side - the sample is shown with the right side uppermost.

COCKTAIL DRIP MATS

Sometimes we are inclined to forget that there are many weavers with just the Rigid Heddle loom with which to work, and what wonderful results they achieve! Therefore, with the threat of Christmas not very far away, we thought it would be a good idea to think about small gifts that can be woven on either a Rigid Heddle loom, a two shaft loom, or the usual four shaft model.

I am bearing in mind that a Rigid Heddle is always 13 threads to one inch, and most looms are 14 dents on the reeds supplied, so please take this as read in the instructions which I shall now give you for Drip Mats, which, incidentally, can apply to any glass with a stem. Most cocktail glasses are around the $1\frac{1}{2}$ inch mark for the stand so the weaving need only be about 3 inches wide to give these mats. With cotton, coloured to match your decor if you wish, lay and dress your loom; I would suggest 6/2's thickness, but if you have some Lyscordet by you, this will do. Now for the weft I would recommend the heavy Spot Gimp and with this weave a pick, and then a pick of the cotton. Allow $3\frac{1}{2}$ inches for each mat, and start and finish with 4 or 6 rows of just the cotton. After you have completed each mat, throw two rows of a distinctive coloured cotton to act as a guide for cutting when you come to making them up.

After you have woven all you need, remove from the loom and divide up by cutting along the coloured lines you have woven for this purpose. Now make a very narrow turning at the top and bottom of each piece. Fold the two ends towards the centre so that the hems just touch, with the hem inside, and then machine or sew very carefully down each side about $\frac{1}{2}$ inch in from the selvedge. If it will help you at all, draw out two warp threads at the point you are going to make these side seams. After all this is done, very carefully cut away the end selvedge thread and unravel the remainder so that you have approximately $\frac{1}{2}$ inch of weft fringe at each side. As this fringe will be of the heavy Spot Gimp and cotton it will give a very pretty effect. Press lightly under a damp cloth and you will be ready to slip the bases of the glasses into these pockets, which in turn will be absorbent and save your tables and cloths from these awkward glass stains which mark so quickly.

SCARF IN SHETLAND WOOL

Another early Christmas thought is the good old stand-by - a scarf. Not to be frowned upon by the weavers with four shaft looms, and a good medium for the weaver with a two shaft loom or a simple Rigid Heddle.

Sometime ago we made quite a number of these for various friends and a few of them are still in use. Woven with the soft two ply Shetland we stock, they are easy to make and if you do not want them too long, say one yard, plus a two inch fringe at either end, you will be able to get a scarf out of 2 oz. So work out the colour scheme and if you intend to weave more than one, try to use colours which will look good on a Natural warp and vary the weft of each scarf. Again I am assuming that your two or four shaft loom is fitted with a fourteen dent reed, but if by any chance it is a 10 dent, as in the case of the 12 inch "Weavemaster", then thread the reed two and one alternately to give 15 e.p.i.

Lay your warp allowing the width to be 11 inches, and the number of ends you will require according to whether you are using a Rigid Heddle at 13 ends per inch, or a 10 dent sleyed two and one, or a 14 dent sleyed singly. The length should be 40 inches plus the wastage you need on your loom, bearing in mind that if you are weaving two or more on one warp, you will only need to add the wastage once.

Do not beat the weft in wool weaving, just bring the batten down on the weft to lay it close against the previous pick. If you beat wool you will make it hard to feel and most uncomfortable to wear!

Make sure that the weft picks are about the same distance apart as the warp ends; make certain that your selvages are neat and tidy as this is the first thing that shows whether you are a careful worker or not.

Leave enough unwoven warp between the first and second scarf to give you a two inch fringe at either end of each scarf after you have tied a row of knots, using about six strands to

each knot. I find that a gap of 6/7 inches between the scarves is ample. When all the knotting has been completed then each scarf needs a steam pressing, and if you want to make your gift look professional, then sew on a label which states that the article is handwoven and last of all, put each scarf into a polythene bag about the size of the scarf when it is folded in half and half again.

THE STANDARD TIE-UP FOR FOOT LOOMS

Although some weavers do not agree with the idea that a standard tie-up is recognized amongst handweavers, this is so, the only variation being that in America the two pedals taking the plain weave are always to one side, and the pattern pedals follow on, but here we set our plain weave pedals in the middle so that when weaving a length of plain weave, one can use each foot for a length of time and then rest it whilst the other foot takes over. Also, by positioning them in the centre it is better for rhythm when weaving in pattern to be able to use the right foot for the pattern on pedals 1 & 2, and with the same foot to operate the binder rows in between, and the same for the left foot when requiring pattern pedals 5 & 6. So, remembering that the pedals number from the right, in the same way as we read a threading draft, the pedals should be tied as follows:-

Pedal 6	Pedal 5	Pedal 4	Pedal 3	Pedal 2	Pedal 1
takes	takes	takes	takes	takes	takes
1 & 4	3 & 4	2 & 4	1 & 3	2 & 3	1 & 2
.. Binder Pedals ..					

Another advantage that I have found with this set tie-up is that when weaving a pattern which calls for three shafts to be used for one shed, (as in the Huch weave in this issue) one can use two pedals to give this without the effort of tie changes and additions, for instance, when 1,2 & 3 are needed together, as pedal 1 controls shafts 1 & 2, and pedal 2 controls 2 & 3, it is very simple to press them both down together as they are next to each other. Even where they are not adjacent, it is no great difficulty to use two feet at once and one soon gets used to the slight change of operation.

A SUMMER DRESS

When Miss Scarfe, of Guernsey came to take some more tuition this year she showed us a very delightful Summer Dress which she had made after seeing something very similar in a Fashion Display on the Island. As it was so simple, both from the weaving point of view and from the dressmaker's angle, we asked her to let us take a photograph of the finished article and then to put into her own words the method which she employed to produce it.

The original was in Royal Blue, but there are plenty of colours for you to choose from if you decide to follow her lead. Incidentally, Miss Scarfe is quite tall, so shorter folk will not need so much length.

"Warp and Weft. 12/2's Mercerised Cotton (same colour)

Warp. $3\frac{1}{2}$ yards long.
30 inches wide, sett at 28 e.p.i.

Threading. 1, 2, 3, 4.

Plain Weave. Shafts 1 & 3, 2 & 4 Alternately.

Materials required. Approximately 1.1b 4oz.

For making up I used a McCalls Pattern No.7196. For the saddle stitch I machined a very narrow tuck diagonally from centre of right shoulder to just below the waist and straight down skirt on the wrong side of the material. I did this before making up the dress and did the white saddle stitch about 1 inch from the tuck after making up the dress".

Perhaps this will inspire you to watch fashions which will give you ideas for your own achievements.

SUMMER DRESS
in
12/2's Cotton.

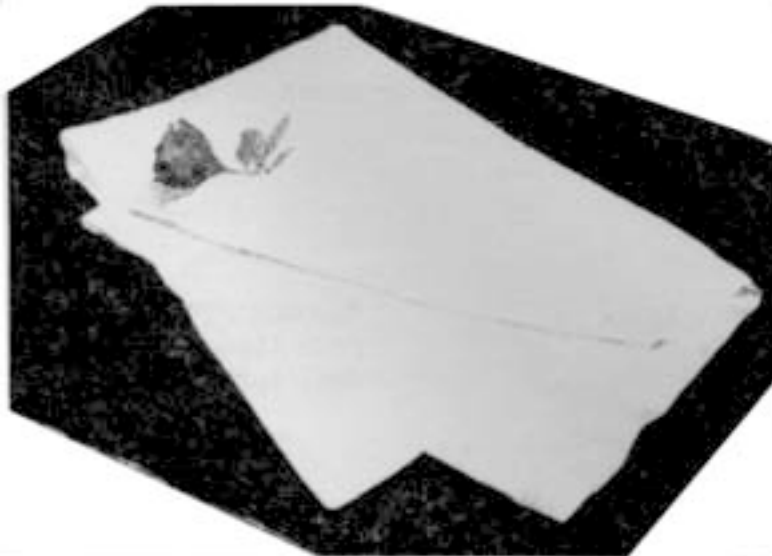

CELLULAR
COT
BLANKET.
in
Pure Snetland
wool.

CONTENTS OF THIS ISSUE OF "LOOMCRAFT"

Volume Three

SUMMER 1964

Number 10.

Editorial

Cellular Carry Cot Blanket

Advanced Overshot Pattern

Grouped Huck - with Sample

Cocktail Drip Mats

Shetland Wool Scarf

Standard Tie-up for Foot Looms

A Summer Dress in 12/2's Cotton

Single copy 1/3d., post free.
5/- per year inc. post.
1 Dollar buys 5 issues.

"LOOMCRAFT" is issued
four times a year -
Jan, April, July & Oct.

LOOMCRAFT



ABOUT WEAVERS

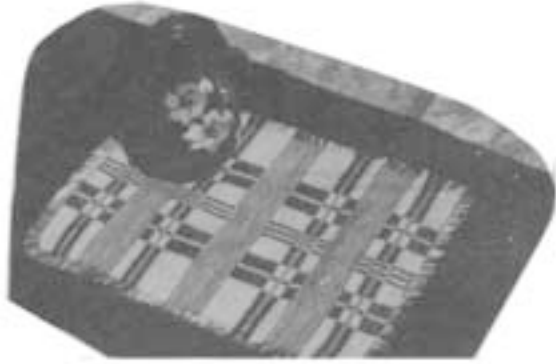

"Summer & Winter"
Weave.

"Hand Towels with
a Difference"

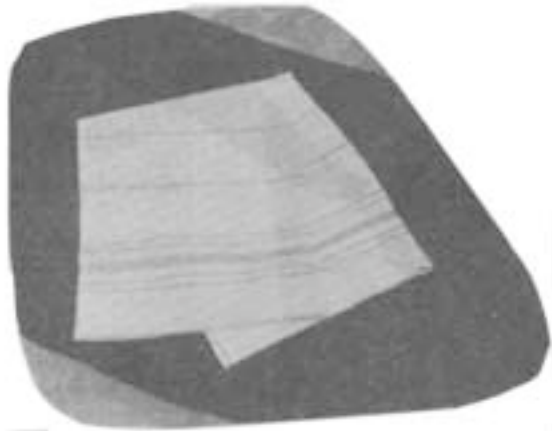

Telephone: Sutton Valence 3245.

"Southside",
Headcorn Road,
Sutton Valence, Kent.

October 1964.

Dear Weavers,

We have renamed and rehoused ourselves in the country! The needlework business was growing out of all proportion and we found that it was inclined to overshadow the weaving side of our activities, so we looked around until we found this property which has just the right proportions.

You will find that we are nearer to London (only six miles East of Maidstone) and for Surrey and Sussex Weavers we have halved the distance. Do try and come to visit us when the nice weather returns. There is ample parking space in our grounds and a line to request our leaflet, giving instructions on how to find us, will be gladly sent.

We shall endeavour to give even better service as time progresses and to make "LOOMCRAFT" more and more interesting as time goes on.

So, with our best wishes for Happy Christmas present weaving, and every kind thought for the New Year, we leave you to prepare the next issue of "LOOMCRAFT".

Sincerely yours,

Margaret A. Norris (Mrs.,)

SUMMER-AND-WINTER WEAVE

This is another weave which can be carried out on a four shaft loom and produces some extremely fine patterns of the block type. As you will see from our illustration it stands out boldly by virtue of the contrasting colours, and these, of course, help it to earn its picturesque name of Summer-and-Winter. Both sides of the weaving are the same except that one side shows the pattern dark - the Winter side, and the reverse gives a light pattern and a dark background - the Summer side.

According to the American weaver, Mrs Meigs Atwater, this weave does not lend itself to linen threads, but I find a warp of linen rather pleasing - in fact, the table centre in our illustration has a linen warp and a Lyscordet weft. I wove several of this pattern some years ago and the pieces have given good service. I do, however, agree that the colours must be a strong contrast - I also have a tray cloth in off-white linen warp and a green pattern thread, but it is not so attractive as the piece we have illustrated.

If you are thinking of trying this pattern, use 12/2's cotton for the warp and binder thread and either 6/2's cotton or Lyscordet for the pattern work. Suppose we estimate for two trolley cloths which can also be used as place mats if you wish. Allow, for the complete project, 6 ozs of 12/2's for the warp and binder thread and about the same for the pattern thread of 6/2's or Lyscordet. Unless you have a set colour scheme may I suggest Natural Egyptian 12/2's so that any Dark Colour can be used as the pattern yarn, but it must be thick enough to be bold when woven.

Lay a warp of 348 ends of 12/2's cotton which will give a width of 16 inches when sleyed 2 & 1 alternately through the dents of a 14 dent reed and so giving a setting of 21 e.p.i.,

The actual threading of the pattern into the healds is very simple and only calls for 4 threads to each unit. We will call them "A" and "B" and are as follows:-

<u>"A" Unit</u>	<u>"B" Unit</u>
3 3	4 4
2	2
1	1

These units are repeated the number of times required for a block, viz:- 4 A, 4 B, calls for 16 ends threaded 1,3,2,3,1,3,2,3, 1,3,2,3,1,3,2,3 and then 1,4,2,4,1,4,2,4,1,4,2,4,1,4,2,4 and so on. Study the following order carefully and then start to thread your healds singly throughout.

A B A B A B A B A B A B A B A
 26 4 1 4 6 1 1 1 1 1 6 4 1 4 26 = 87 units of 4 threads = 348 ends.

The weaving is just as simple once you have mastered it; two shuttles are required, one for each thread, binder and pattern. Make a small heading of about 6 or 8 rows with the 12/2's binder thread and then proceed as follows, again in-unit order:-

Weaving Lifts.

<u>"A" Unit.</u>	<u>"B" Unit.</u>
Shafts 2 & 4 Pattern	<u>Shafts.</u> 2 & 3 Pattern
3 & 4 Binder	3 & 4 Binder
1 & 4 Pattern	1 & 3 Pattern
1 & 2 Binder	1 & 2 Binder
2 & 4 Pattern	2 & 3 Pattern
3 & 4 Binder	3 & 4 Binder
1 & 4 Pattern	1 & 3 Pattern
1 & 2 Binder	1 & 2 Binder

So, you will weave "A" unit 26 times and then change to "B" unit for 4 times and so on.

This type of weaving is very flexible and you can increase or reduce the number of repeats of any unit according to the size of block you require. I am sure you will like it.

Leave a gap in the weaving after the small heading at the end of the first trolley cloth - this can be regulated by weaving in one or more warp laths to give double fringe and then weave the second one. After fringing they should be steam pressed to set the weave.

DO YOU KNOW? Log Cabin Weave is a plain weave in which patterns are produced through the alternation of light and dark colours in warp or weft or both.

HAND TOWELS WITH A DIFFERENCE

I expect some of our readers will feel that it is an old, old faithful coming up again, but I do feel that hand towels are always an appealing gift, and wear so well against those you can buy ready made from the large and small stores throughout the entire world. A well designed and well made handwoven towel is always a joy to use and looks good anywhere.

During the late Summer we have had many friends calling for yarns and a look round during their holidays on the Kent coast, and the latest addition to our stock of handwoven products has caused a lot of admiration, so I have decided that come what may in the way of a few folks being disappointed with something of a repeat performance, I will give the details for the latest one and remind you of another that has been given in an earlier number of LOOMCRAFT.

We used a seven dent reed, which was double sleyed to give 14 e.p.i., but as the Tuffle yarn, (fine gimp) does not have any knops in its construction, you could get by with a fourteen dent reed if you are careful. We made ours to finish at 20" x 30", so allow 33" length for each one, plus the wastage which you need for your particular loom. The cost of each towel will be under 3/-, but if you set up for four or more on one warp it could work out as low as 2/6d each.

The warp consists of one 6/2's cotton end and one Tuffle gimp end alternately, except for the selvedge. Lay your warp as follows:- 8 ends of cotton (for the selvedge), then one end of Tuffle gimp in Green, and then one end of 6/2's cotton, repeating this until you have 18 of the Green threads, plus the cotton ends. Now warp eighteen ends of Gold Tuffle with a 6/2's cotton after each one. The next stripe is still 18 ends of Tuffle gimp, but this time in Yellow, with a cotton following each one, now a narrow stripe of White Tuffle and 6/2's cotton alternately; this time it is 18 ends of Tuffle. For the middle stripe which is a little wider, use one of the three colours already engaged and warp 24 ends of the coloured Tuffle with a cotton end after each one. For the remainder of the towel work backwards, in other words, from the 8 White, then 18 Yellow, 18 Gold and finally 18 Green with a 6/2's cotton end after each one. For the final selvedge lay 8 ends of all cotton which will give 9 cotton ends at one selvedge, but this will balance very well. In all you

will have 332 ends, which are single through the healds, but 14 e.p.i., through the reed, according to the size reed you are using.

For the heald threading it is plain throughout, for a two shaft loom it is 1,2,1,2 and for a four shaft loom it is 1,2,3,4, repeat. This is very straightforward and you will not have any trouble I am sure.

The bulk of the weft is in the slightly thicker gimp, and is carried out in the unbleached. If you wish you can use one or other of the coloured Tuffle yarns every three inches, weaving four rows to give colour, but the weaving is plain throughout. You can, of course, put a few more coloured rows at more frequent intervals at either end of the towels to make them more attractive. Allow one inch hem at each end, and the actual weaving should measure a good 33 inches whilst on the loom. This will result in a towel 20" x 30" when finished. It is a good idea to have a different coloured stripe for the decoration in the weft for each towel, and in this way bring out one of the colours more than the others.

For something a little heavier I would suggest that you use the unbleached gimp in the warp, still using the setting of 14 e.p.i., and introducing your colour by means of 6/2's cotton of which, no doubt, you will find you have a good supply consisting of the odd pieces left on spools from other weaving projects. Then the weft is again all unbleached gimp, with perhaps a little of the warp colours thrown through from time to time.

Whichever you may decide upon, the best way to take out the newness of the dressing is to soak the towels in rain water for 24 hours and then let them drip almost dry before their final steam pressing.

For four of the Tuffle yarn towels you will need 8 ozs of the 6/2's warp cotton, one each of the four colours of the Tuffle yarn, and 8 ozs of the medium unbleached gimp. Of these quantities you will have some surplus, but these are the smallest amounts available. For the heavier towels allow 8 ozs of the unbleached gimp, plus odd amounts of coloured 6/2's cotton from your stocks, for each towel.

SUITING IN HUCK

We are delighted to know that the sample of Grouped Huck which was given in the July number of LOOMCRAFT proved so popular with a lot of our readers. We try to give you something which is out of the usual run of things, but, whereas we may think a pattern is fine, it may not find favour with the next reader. A great variety of uses has been thought up for its adaption and we hope that this one will be another winner. Although it is given here in Cotton Yarns, we can see it in woollen material for Spring outfits, and also used for household fabrics. Why not give it a trial and if you find an outstanding use for the pattern, do write and tell us all about it.



The great secret of this number is the laying of the warp, and if you take care to use the two threads in the order I have given, then the rest of the setting up will fall into place. Remember that after the four thicker threads for the selvedge, all other thick ones should come on the same shaft, either shaft one or shaft four, and always next door to each other. THIS IS THE GOLDEN RULE.

We used two colours that are very popular at the moment, Black and White either way would be very striking, but with Winter almost upon us we felt that the Nut Brown and Off White would look warmer.

You should use a twelve dent reed which will then be double sleyed throughout to give 24 e.p.i., and also help the 6/2's to give a closer effect. Two shuttles are needed, one for each thickness of yarn, but more of that when we get to the actual weaving.

To give a width which is usual in Dress material weaving, I suggest that you lay a warp to give a width on the loom of 32". This allows for a little loss of width on the loom and the finished cloth will then be 30/32" ready for tailoring. We estimate that warp and weft will require 5 ozs per yard of this width in the 12/2's cotton, plus perhaps two ounces of the 6/2's for the heavy stripes. These amounts are based on a length of at least 2 yards woven cloth and includes the wastage on the loom.

A warp laid as follows will give 774 ends:- 4 6/2's (for selv.), 13 12/2's, ϕ , 2 6/2's, 3 12/2's, 2 6/2's, 3 12/2's, 2 6/2's, 14 12/2's; repeat from ϕ 27 times more, then 2 6/2's, 3 12/2's, 2 6/2's, 3 12/2's, 2 6/2's, 13 12/2's and 4 6/2's for the final selvedge.

Now the threading should be carried out as follows, bearing in mind that although the threads are double through the reed, when threading the healds, these are single throughout.

Threading Draft.

	3 3	4 4
	2 2 2 2 2 2	3 3
	11 11 11	2 2
	. Block "A" ..	1 1
	. .14 threads.	Selv. Shafts
	. Plain weave	
	.12 threads.	
4	44 44 44	
3	3 3 3 3 3 3	3 3 3 3 3 3
2	2 2	2 2 2 2 2 2
1		
Selv.	..Block "B"...	.Plain weave.
	..14 threads..	.12 threads.

Always remember that a threading draft is read from right to left. You will find that you will finish up the last of the 12/2's with the second bank of 12 threads plain weave. You then omit Block "B" and thread the four 6/2's threads for the final selvedge.

The actual weaving is fairly simple once you have mastered the rhythm and repeats. Between each block of pattern you will see from the sample that we have a section of plain weave. So, start with one section of this, beginning with shafts 1 & 3 lifting together and followed by 2 & 4; repeat this until you have 12 picks. Now weave the blocks "A" and "B" as I have given them on the following page.

Block "A"				Block "B"			
Pedal.	Shafts.	Times.		Pedal.	Shafts.	Times.	
3	1 & 3	1	12/2's.	4	2 & 4	1	12/2's
1	1 & 2	2	6/2's	5	3 & 4	2	6/2's
3	1 & 3	1	12/2's	4	2 & 4	1	12/2's

Weave A,B,A,B,A, now weave 12 rows of plain weave again, but starting with shafts 2 & 4, then 1 & 3 alternately. Next weave the other block of pattern with B,A,B,A,B, repeat in this order throughout and if possible finish with a band of plain weave.

Now just a word about the two shuttles. Charge one with the thinner yarn, the 12/2's, and the other with the thicker, the 6/2's Use the thin one for the majority of the weaving, only bringing in the 6/2's for the picks which are repeated, and as they both lie in the same shed, the second one is obtained by passing the shuttle under the extreme end thread to secure the first pick. After the third repeat you may either cut this thread off or run the yarn up the side of the selvedge for the next block, it is just a matter of taste, but if you run it up I do suggest that you wrap the thinner yarn round it two or three times during the plain weaving.

AN APRON FOR THE YOUNG MOTHER

Fancy aprons - Garden aprons - and now an apron for the mother with a young family. These we have always found most useful and popular, so it may appeal to some of our readers for Christmas presents.

These are quickly made and do not cost very much for the materials. The whole of the warp is in 6/2's warp cotton and set at 14 e.p.i. For the weft the medium gimp in unbleached has been used with just a little relief in the coloured bands of the "Rosepath" pattern etc.,

This is really meant to be a pattern for the four shaft loom, but for anyone with a two shaft loom or even, at a pinch, a rigid heddle loom, then the bands will have to rely upon the colour only.

The width of the weaving on the loom is 24 inches, but if your loom is not wide enough to give this, then I would suggest

that you weave three pieces rather than two so that the apron would have a panel in the centre, with a piece joined at each side. We shall, however, refer throughout the article to the material in one width; those weavers with smaller looms will soon gather that the length of the warp etc., must be tripled to give the finished length.

If you can think of four people to whom you will give this type of apron, then you can also weave the pocket material without any waste. On this assumption I will give the instructions on these lines.

Lay a warp of 6/2's cotton $3\frac{1}{2}$ yards long plus whatever wastage your particular loom takes. The warp should be 336 ends long and, as already stated, it will be sett at 14 e.p.i., and the healds are threaded single throughout. For the pattern you will need the "Rosepath" threading after you have allowed for the first and last eight ends of the warp for selvedge threading which is 1,2,3,4,1,2,3,4. For the "Rosepath" it is 1,2,3,4,3,2,1,4, repeated throughout until the last 8 ends are reached and these are again 1,2,3,4,1,2,3,4.

Now when all the checking for crossed threads and tension is completed, the weaving commences using the Gimp, and in plain weave make enough to give the double thickness of a one inch hem, and then begin the coloured bands which will help to use up some of the odd yarns, preferably of the 6/2's or coarser thicknesses, using the following lifts:- once only for each lift, AND NO BINDER THREAD, shafts 3 & 4, 1 & 4, 1 & 2, 2 & 3, 1 & 2, 1 & 4, 3 & 4. Now four plain rows with the gimp and repeat the coloured pattern lifts twice more, with the four plain rows of gimp separating them. Repeat the four rows of gimp after the third pattern band and now weave four plain rows in colour following each row with one of unbleached gimp.

Follow these pattern bands again and then the four coloured rows of plain, finish off the colour band with a repeat of the three "Rosepath" patterns and their dividing gimps, but do not add the four rows of plain weave in colour.

The body of the apron is then woven in plain weave with the unbleached gimp until the weaving is 22" from the beginning, then two rows of a coloured thread are now woven to act as a cutting line for the finishing off. Repeat these instructions for the

remaining three aprons and then use up as much of the warp as possible in plain weave with the gimp. This plain strip will provide the 3 inches you will need for each waist band and also enough for the pockets which look so attractive.

Remove the weaving from the loom and steam press to make the cutting easier. Separate the four aprons and the plain weave. Now cut four strips right across the material for each waist band allowing a good 3 inches for each. The remaining piece should be shared out between the four aprons, and if you have woven up all you can and your calculations for the wastage is correct, it should give you approximately 6 inch squares.

For the tapes we bought one inch width tape and allowed one yard for each apron, but I have since heard that coloured furnishing tape looks better - I leave it to you. We pleated the apron into a 15" waistband, which was the 3" piece doubled and neatly tucked in. We shortened it to give the 15" and machined it onto the apron, arranging the pleats to give three on either side of a plain panel in the middle of about four inches. The yard of tape was divided, a small hem made at the extreme ends and then affixed to the waistband. The one inch was made at the bottom and the pocket piece neatly hemmed and machined on at an angle about 5" down from the waistband. After the apron had been lightly steam pressed once more, it was ready for presentation. We hope that you will like them.

Allow 10 ozs of 6/2's warp cotton for the warp and 12 ozs of unbleached medium gimp for the weft, pluss the odd pieces of 6/2's coloured cotton for the rows of coloured "Rosepath" and plain weave. In this way each apron should cost as little as 3/6d. each.

DO YOU KNOW? That the word "Tartan" comes from the Spanish "tiritana" meaning cloth with design in small checks? That there are 130 commonly used authentic clan tartans? Colours which occur most commonly in Scotch tartans are scarlet, royal blue, moss green, yellow, black and white and occasionally grey, azure and cerise.

COLONIAL OVERSHOT PATTERN

This is the fourth and last of our present series of these and for this one I must stress the need to have a good firm beat at your disposal as this pattern must be balanced to give the square effect it calls for.

The setting up instructions are as before and I advise 12/2's cotton for warp and binder with 6/2's cotton or a similar thickness for the pattern. A fourteen dent reed double sleyed will give 28 e.p.i. If the right beat is obtained then the completed pattern will result in a square of approximately twenty inches. A binder thread follows every pattern row.

THREADING.

```

          4 4 4      4      4 4 4 4 4 4 4 4 4      4 4 4      4
        3 3 3      3      3 3 3 3 3 3 3 3 3      3      3
    2 2 2 2      2 2      2 2      2 2      2 2      2
    1 1 1      1 1 1 1      1      1      1 1 1      1 1 1
    .....      .....      Outer Block      .....      Selv.
                               (31 ends)

    4 4 4      4 4 4 4 4 4      4 4 4 4 4      4 4 4 4 4 4
      3 3 3      3 3 3 3      3      3      3 3 3 3
        2 2 2 2      2 2 2      2 2      2 2 2
    1      1 1 1 1 1 1      1 1 1      1 1      1 1 1      1 1 1
    .....      Blooming Leaf and Inner Border      .....
                               (113 ends.)

        4 4 4 4      4      4 4 4 4      4 4 4 4 4 4 4 4 4      4
        3 3      3 3      3 3 3 3 3 3      3 3 3 3 3 3
    2 2      2 2      2 2      2 2      2 2      2 2
        1 1 1 1 1 1 1 1 1 1      1      1      1 1 1
    Link .... Centre repeat 10 times... ø.....
                               (30 ends)

```

Thread from right and proceed as given until 10th repeat of centre; now thread the three ends marked "link" and then commence at ø and thread BACKWARDS right through including selvedge. This will need 601 ends. Pedal loom workers will use standard tie-up.

WEAVING LIFTS.

<u>Shafts</u>	<u>Pedals</u>	<u>Times.</u>		<u>Shafts</u>	<u>Pedals</u>	<u>Times.</u>
4 - 1	6	4		3 - 4	5	1)
2 - 3	2	2	⊕)	4 - 1	6	4)
3 - 4	5	2	} Blooming Leaf.	1 - 2	1	2) Weave
4 - 1	6	2		4 - 1	6	2) 9
3 - 4	5	2		1 - 2	1	2) times
4 - 1	6	2		4 - 1	6	4)
3 - 4	5	2		3 - 4	5	1)
2 - 3	2	2		2 - 3	2	2)
1 - 2	1	1				
4 - 1	6	1		3 - 4	5	1)
3 - 4	5	1		4 - 1	6	4)
2 - 3	2	1		1 - 2	1	2)
1 - 2	1	2		4 - 1	6	2) Once
4 - 1	6	2		1 - 2	1	2)
3 - 4	5	2		4 - 1	6	4)
2 - 3	2	2		3 - 4	5	1)
1 - 2	1	2				
4 - 1	6	4				
3 - 4	5	2				
2 - 3	2	2				
1 - 2	2	2				
4 - 1	6	2				
3 - 4	5	1				
2 - 3	2	1				
1 - 2	1	1				
4 - 1	1	1				

Now work from ⊕ at beginning and back for second Blooming Leaf, this should work out to give a square of approximately 20".

Now omit last lift and work backwards to ⊕

For a cushion cover repeat the instructions if you wish to have both sides patterned. It would also look very good if the centre repeats were continued until enough had been woven for panels of a draught screen. I am sure once you have tried this pattern you will weave it again and again.



Apron for the
Young Mother.

Colonial Overshot
Pattern

(Quarter of draft
given)

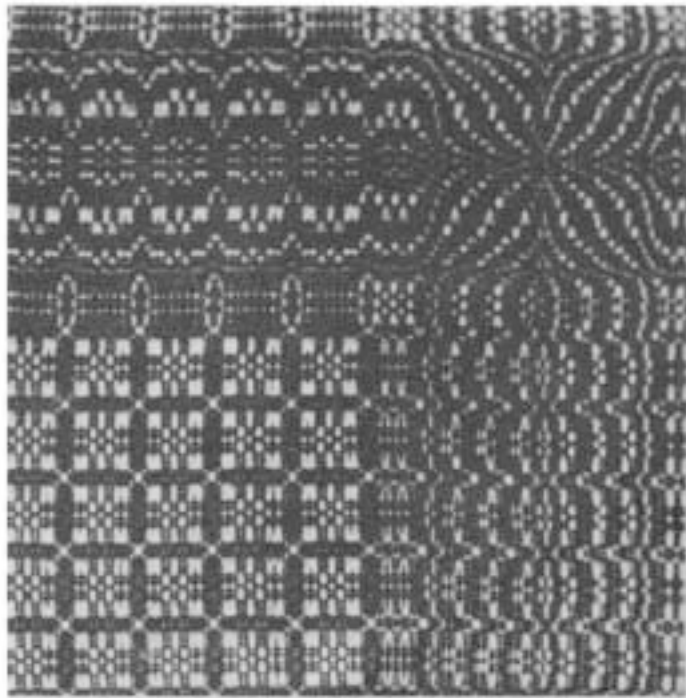

CONTENTS OF THIS ISSUE OF LOOMCRAFT

Volume Three

AUTUMN 1964

Number 11.

Editorial

Summer & Winter Weave

Do you know?

Hand Towels with a Difference

Suiting in Huck - with Sample

An Apron for the Young Mother

Another Colonial Overshot Pattern

Single copy 1/3d., post free.
5/- per year inc. post.
1 Dollar buys 5 issues.

"LOOMCRAFT" is issued
four times a year -
Jan. April. July & Oct.

LOOMCRAFT

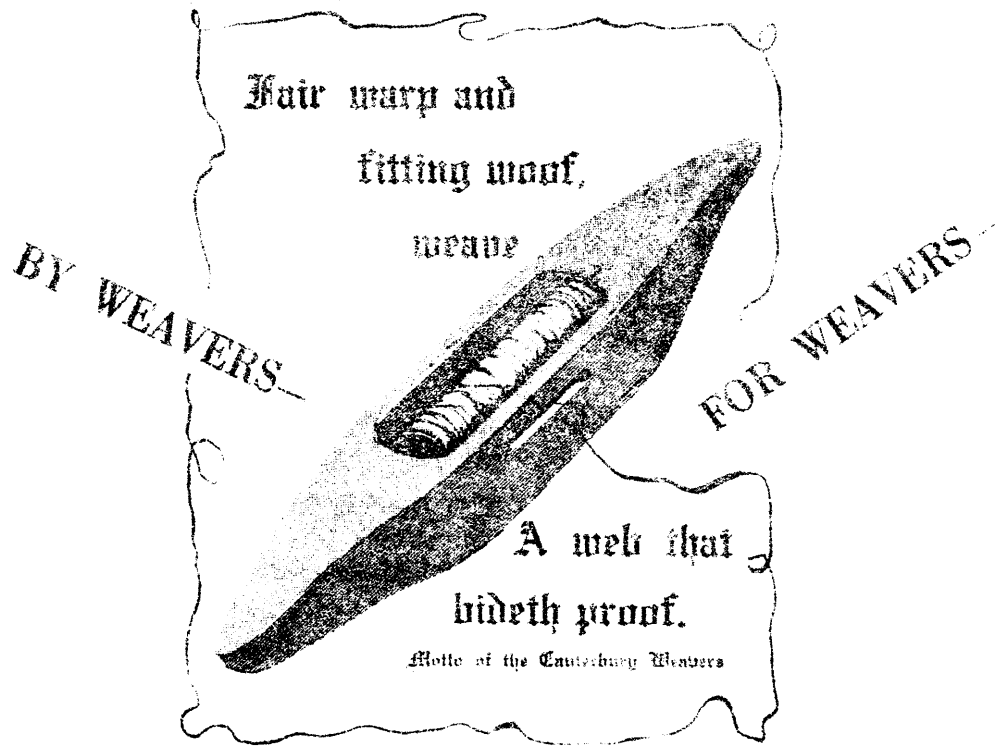

ABOUT WEAVERS

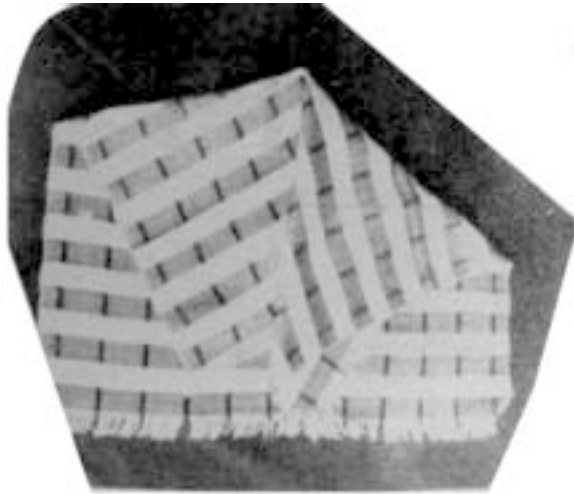

HEAD SQUARE IN
FINE WOOL



TWEED JERKIN

Tel. No. Sutton Valence. 3245.

"Southside,"
Headcorn Road,
Sutton Valence,
KENT.
January 1965.

Dear Weavers,

We are into another New Year and I send you every Good Wish for a most happy and successful year from all of us here at "Southside." It is our hope that we shall give you a great deal of inspiration and many ideas for weaving through the medium of LOOMCRAFT.

Although the first month is now well under way, we would like to thank all the many friends that have sent us Christmas and New Year Greetings. We appreciate them very much, and wish we could write to you all, but that would be something of a mammoth operation! Thank you all, very much.

We are delighted that so many of our friends, both old and new, have been to see us in our new surroundings. Also the large number of enquiries we have had for "details how to find you, please." On the back of the Special Offer list with this number you will find instructions for doing just that, and we look forward to greeting and meeting many of you during the year ahead of us. All are welcome, and there is ample parking, just drive in, please.

Quite a lot of ideas are being prepared for this year's LOOMCRAFT, and we hope that the article you had been needing will be amongst them. If not, please drop us a line and we will make a note of your requests.

With every good wish,

Sincerely yours,

(Mrs) Margaret A. Norris.

HEAD SQUARES IN FINE WOOL

Several requests have been made for Headsquares just lately, so we looked up previous copies of LOOMCRAFT and find that apart from the article given for scarves etc with a warp of fine silk and weft of fine wool, nothing in this line has appeared since the very early days of the magazine. I rather think we are inclined to think that as it is mostly plain weave it was not necessary, but now I think I must try and help some of our readers who would like to use this medium, but are a little hesitant about starting.

The one drawback at the moment is the large packaging of the fine wool which is normally used for the Headsquares and scarves. At one time we were able to supply this in 2 oz hanks, but the makers found that there was not a large enough call for it in this make-up, so now we can only obtain it in 1 lb cones, which are too large for the average weaver. I understand that it is possible to purchase a very fine knitting wool made up in $\frac{1}{2}$ oz balls, but these are fairly expensive. Therefore I will hank off some 1 oz skeins for you, but I may have to keep you waiting 7/10 days for this service, according to the pressure of other orders, and I shall have to charge 2/- per oz.

This is a balanced weave, therefore the warp takes only a little more than the weft, to allow for the warp wastage. We find that the best reed for Headsquares, Scarves or Stoles is a 16 dent, which can be double sleyed to give 20 e.p.i. If you already have a 14 dent reed, and do not feel that the outlay for a 10 dent is justified, then you must slightly adjust the number of ends to give 21 e.p.i. and sley the 14 dent reed 2 and 1 alternately throughout. For this article I shall give instructions for a 10 dent reed.

Let us say that you are proposing to weave 2 headsquares so to give a finished width of 27" you will need 476 ends a little over 2 yds long, according to how much wastage your loom takes.

The heald threading is single throughout, and is plain weave, 1,2,3,4, repeated. The reed is sleyed to give a slightly spaced warp which will break the monotony when weaving, and is as follows, double sley the first 17 dents of your width which uses up the first 34 threads. New leave 3 dents empty; in this way

you have allowed for 2 ins in width. Repeat this until you have 13 spaces of 3 empty dents each, and 34 ends still to be threaded, these form the last band of warp.

After the final tie-up and tensioning has been done you are ready to start weaving. We shall assume that you have selected a fairly neutral colour for the warp, and that you will use the warp colour and one other colour to weave into the weft. We found that a pale Lemon was a very useful colour, also a light Beige. Weave 20 - 22 picks of the lemon and then change to Black, (or some other darker colour), throwing the same number of picks of this. If laid correctly you will now have slightly more than 2 inches of weaving under tension, which when released from the loom will contract and give 2 inches.

Proceed in this manner throughout if you wish for coloured stripes, but it would be a good thing to use one or other colour all the time and instead of an unbroken length of weaving leave corresponding gaps in the weft to match those of the warp. This can be done by laying 34 rows and then carefully arrange the 35th approx 3/10ths from the 34th row, or a piece of flat stick or cane the right width laid in the shed before changing for the 35th row would give you a ready made gap, but make sure that your weft is loose enough to allow the cane to be removed after about 4 or 5 picks, and then kept ready for the next gap when required. Other ideas will suggest themselves as you continue, and perhaps you will become so quick and original at this type of weaving that your market will be most remunerative.

Weave about 28" and then leave a space large enough to give a fringe for the first headsquare of 1 inch and the same for the next one. When removed from the loom steam press the material before cutting apart. We found that they did not need knotting. Allow 3 oz of fine wool for each headsquare.

-0-0-0-0-0-0-0-

LOOMCRAFT Subscriptions.

Unfortunately there is the threat of possible increases in present postal charges, so we regret that we cannot accept more than one years subscription at a time. We are sure you will appreciate why we must make this condition, and bear with us if it cuts across your usual habit. Apart from the increase of postal rates it may also affect the printing costs, and as we are running so close to our tight budget, plus a helping hand from the Yarn sales, we must reluctantly make this condition.

CANE MATS ON A SPACED WARP

Although we are in the grip of Winter, we cannot ignore the fact that the Spring and Summer will soon be here again, and that, to my way of thinking, means picnic meals, and all the preparations which eating out of doors calls for.

It is all very easy to pack sandwiches etc, and sit with it on our laps to eat it, but nowadays there are so many tempting advertisements for inexpensive furniture which fold up and stow away in the car, that we are all inclined to invest in some.

Now comes the problem of tablecloths or table mats. Both forms are subject to untidyness if there is any wind at all, so the best way to make our outdoor tables look attractive is Cane Mats. These are so quickly made, and very inexpensive materials produce colourful mats.

Look in your oddments box for anything in 6/2's cottons, and no matter how little the amounts are they can all be used up on a spaced warp. As there is no pattern weaving required, a two shaft loom, or even a rigid heddle loom can be used, providing you can beat down the weft with either a beater, or at least an old table fork. It is most important that the weft is packed as closely as possible - that is the secret of the whole project, so if your loom cannot do this for you then, although it will slow up the operation a little it is worth it to have finished work which looks good.

All you need are five lots of 12 warp ends, and these need to be a good yarn and a half long to produce 4 mats. When you have the 60 ends of cotton ready they should be single through the healds, but when sleying the reed, which should be around the 12/14 dent mark, thread 12 single through each dent, and then leave 24 dents empty. Repeat this until you have the five groups. When ready for weaving cut the cane in rough lengths of 15 inches, wet the cane and wrap in an old towel to take out any curves. Then use one piece for each pick, and remember to beat well. Each mat needs to be 9 inches of weaving. You can throw about 6 picks of cotton at the beginning and end of each mat if you wish. Leave enough warp to give a knot at the top of each group.

A TWEED JERKIN TO MATCH YOUR SKIRT

Most of us can manage the tailoring of a plain skirt in tweed, and how proud we are when folks say, "Aren't you clever!" Very few can aspire to the tailored jacket to match, or even a waistcoat, but I am sure a straight jerkin is within the bounds of most of us.

Set a warp to give about $\frac{4}{5}$ inches wider than half the bust measurements needed, so a standard 36" will need $\frac{22}{23}$ inches on the loom. For both the back and front allow about $1\frac{3}{4}$ yards length.

We use Scottish Tweed yarn sett at 14 e.p.i., and wove ours in plain weave using the same colour as the skirt for the base. Introduce narrow bands of colour if you wish, but remember this may tie you as to the jumpers and blouses you may wear with the outfit. As our skirt was plain Oatmeal, and the base of the Jerkin the same, we introduced various browns, which toned with shoes etc.

As it was just plain weave, we feel that there is no need to go into detail as to how it should be woven. We feel sure that only a weaver with some experience will attempt tweeds, so this will be child's play to them.

After the piece of tweed has been scoured and finished, the making up proceeds as follows:- Hem the two ends and then find the middle of the cloth, both lengthwise and widthwise. For the neck opening cut down the middle on one side for $10\frac{1}{2}$ inches, this will be the front, and another $1\frac{1}{2}$ inches down the back, giving a neck opening of 12 inches. If you wish a larger opening then you must adjust accordingly, but remember there is still the fringe to come, which will give a little more. Now machine round this slit, beginning close up to one end, and curving out to about one inch from the slit by the time you have machined about 2 inches. Proceed with the one inch from the slit until you are nearing the other end of the slit, and then slope in towards the extreme end. Work down the other side to correspond with the first side. When the cottons have been secured, very carefully fray out the warp ends on the slit side, and this will give you a neck fringe. The next thing is to hem up the edges on either outside selvedge for thirteen inches, both back and front. For the remainder of the middle of each side, machine as for the neck opening, starting close to the end of the side hems and sloping out to about one inch from the selvedges. When this has been done very carefully cut the selvedge threads and unravel as for the neck, to give the armhole fringes. We then

fixed tapes 8 inches up from the bottom edge on the back at either side, these are to tie in the front, under the front flap of the jerkin, so that when the front is wrapped to the back on either side, it can be girdled with a belt, and make a neat fitting.

Another finishing touch which could be substituted for the belt, would be to slightly dart at the waist line, back and front, and sew up one side, fitting a zipper to the other with a detachable slider, so that it open up completely. We hope that this idea will appeal to you, and so make a break from the usual run of cardigans.

Altogether the jerkin should weave out of a little less than 12 ozs of Scottish Tweed yarn, or if you are using fine Shetland tweed yarn I would suggest you allow 8 ozs and a setting of about 20-21 e.p.i.

0-0-0-0-0-0-0-0-0-0-0-0-0-0-0

SAMPLES.

When I first came into this business, just over nine years ago, the practice of sending out samples upon request, was covered by a fee of 6d., but I found that folks tended to retain samples and price lists for such a long time afterwards, that very often it meant extra correspondence to write and explain this when an order was received with insufficient cash to cover either the yarns ordered or the postage involved. I quickly curtailed this, and asked for a list of yarns my customers were interested in for the very immediate future, and sent with a current price list. Now it is our practice to include an up-to-date list with every issue of LOOMCRAFT, so please only ask for the numbers you need, and do not request samples which are not likely to be of interest to you in the immediate future as this calls for unnecessary labour which could have repercussions on our prices. I spent a day and a half preparing and mailing samples in November, and of the 50/60 I sent out I think I have heard from perhaps 10 or 12. That time could very much better have been used in preparing future articles for LOOMCRAFT. Will you please bear this in mind? Thank you.

WAFFLE WEAVE

Having had such appreciative reports of the Cellular blanket pattern, we thought you might like a Waffle Weave pattern to follow on. This sample is in cottons, but if you are thinking in terms of Cot Covers, then I would suggest you use Nylon wools both 3 ply and Double knitting, instead, and so make the frequent washings an easy matter, with no shrinkage headaches!



I propose to give you the instructions for weaving exactly as the sample, but there are alternatives which may appeal to you, such as plain 8/2's cotton for the warp, sett at 14 e.p.i., and a coloured weft of thick weaving cotton. It may also look a very likely subject for guest towels, and here I would suggest either all linen, with 25/2's for the warp and 8/2's for the weft, or again, substitute 12/2's Egyptian cotton for the warp, and retain the 8/2's linen for the weft, setting at 28 e.p.i. It lends itself to stool tops, cushion covers and a host of other needs - in fact it is a very useful pattern to have in your records.

Let us suppose that you are proposing to weave a piece of cloth just as the sample, which you wish to finish up at 40 inches with a hem at either end, and approx 24 inches wide. We shall use 12/3's plain cotton for the warp, and sley it singly in a 16 dent reed. Lay a warp of 400 ends which will give you 25 inches in the reed. If you make the warp 2 yards long you will have at least 45 inches of weaving, perhaps a little more, it all depends upon how much wastage you need with your particular loom. Therefore with the hems at either end you should have a good 40 inches when finished.

The threading is single through the healds, and is as follows:-

4	4		4	4		4	4		4
3	3		3	3	3		3	3	
2	2		2	2	2	2	2		2
1	1		1	1		1	1		1
Selv.			Pattern repeat.			Selv.			Shafts.

When all tie-ups and tensioning is completed the weaving can proceed, and the lifts are used ONCE ONLY in each repeat, therefore no binder rows are necessary, and with a single shuttle the work should grow very quickly once you have mastered to lifts.

Now a word to those weavers with pedal looms. If you are using the standard tie-up I would advise you to use two pedals together where the pattern calls for three shafts in operation, this can be achieved by simple alteration as follows:- Pedal 6 carries shaft 1 only, Pedal 5 carries shaft 4 only, and Pedal 4 carries shaft 2 only, so untie the cords from lamms to Pedals for these, and leave Pedals 3, 2 and 1 just as they are. In this way you will quickly see that when 3 shafts are called for you will depress one Pedal on either side of the row to obtain these lifts. I often use this kind of thing and find the rhythm very easy to learn.

<u>Shafts.</u>	<u>Pedals.</u>	
1,2 & 4	1 & 5	
1,2 & 3	1 & 6	
1 & 3	3	
2	4	Repeat the lifts in this order
1	6	throughout for the length
2	4	required.
1 & 3	3	
1,2 & 3	2 & 6	

Always watch the SHAFTS when changing sheds, and you will soon spot any error in the lifts. Steam press the material to set the hthreads and then hem at either end.

For the length we have given you will need about 8 oz of 12/3's plain cotton, and upwards of 1 lb of 6/3's for the weft. For any changes to the thicknesses of the yarns used you adjust your quantities accordingly. Perhaps it would be a good thing to weave a length just as given first of all, so that you can learn the pattern and then make the adjustments you may find necessary for your second project.

0-0-0-0-0-0-0-0-0-0-0

Please remember to enclose a S.A.E. when asking for price lists.

COTTON & PLASTIC TAPE MATS

These came to us from Sweden, and now appear to be firm and lasting favourites in this country. We have woven them on cotton warps, and also on warps of the $\frac{1}{2}$ inch plastic tape, the same thing as the weft, but for this article I think we should confine ourselves to the type which takes the cotton warp, as these do not call for such trouble in preparing the warp as the all plastic ones.

They are most suitable for many purposes such as kitchens, bathrooms and the toilet. They do not present any difficulty in weaving, they are comparatively inexpensive, most certainly NOT cold to stand upon, quickly washed and dried. They give endless wear, and I recommend them most strongly.

The warp is made of 12/3's plain cotton, and sett at 9 e.p.i. To give a finished width of 18" lay a warp of 182 ends, and for two mats, each 30 inches long, plus fringes, it should be $2\frac{1}{2}$ yds long.

For the pattern draft I think Rosepath offers the better choice, as it can be modified in the actual weaving, so making for variation in the weaving. For the number of ends I have suggested you will have 22 repeats of the eight thread draft, plus the selv-edges.

	4	4	4	4
3		3 3	3	3
2		2 .2	2	2
1		1 1		1
selv.		Pattern repeat	selv.	Shafts.

When all the checking of tie-ups and finally tensioning has been completed, it is the first job to weave in plain weave, using shafts 1 & 3, and 2 & 4 alternately, 10 rows with the 12/3's cotton. This is to give a heading, and also to add the finished touch to the completed article.

I would suggest that two colours of plastic tape are used, and if one colour is used for the pattern and the other for the binder on the first mat, this order can be reversed for the next.

<u>Weaving Lifts.</u>	<u>Shafts.</u>	<u>Pedals.</u>	<u>Times.</u>
	3 & 4	5	1
	1 & 4	6	1
	1 & 2	1	1
	3 & 4	5	2
	1 & 2	1	1
	1 & 4	1	1
	3 & 4	1	1

A Binder row follows each Pattern row, and is 1 & 3, 2 & 4, with the other colour. Repeat these lifts for 30 inches, and then repeat the 10 rows of plain weave with the 12/3's cotton as at the beginning of the mat. Now be sure to leave sufficient warp unwoven to give about 3 inches for the knotted fringes on each mat. Weave the second mat in the same manner, but reversing the colours of the plastic tape. When all weaving has been completed remove from the loom, divide through the middle of the unwoven warp between the two mats, and make a knotted fringe very close to the cotton heading at each end of each mat. It is rather nice to have a second row of knots, but you may prefer to leave them with only one row, in which case cut the fringes fairly short, about one inch looks best.

You will need $\frac{1}{2}$ lb each of two colours of $\frac{1}{2}$ inch Plastic tape, and $\frac{1}{2}$ lb of 12/3's plain warp cotton. This will give you sufficient materials to produce two mats, which should measure 18 inches wide, by 30 inches long, plus the short fringes.

This pattern can also be used with very thick cotton yarn, or if you have some 6 ply Rug wool by you it can be used in the same manner as the plastic tape, and would produce very fine bedside rugs. In all cases, whatever the yarns used, do remember to beat well, so that all yarns are packed closely. With the Plastic tape you will find that until a few rows have been woven it will tend to rise in the sheds, but this is soon overcome by the following weft picks, and the final heading of 12/3's cotton "seals" it in at the end of the mats.

o-o-o-o-o-o-o-o-o-o-o

DID YOU KNOW? E.P.I. stands for "ends per inch" when working out the number of warp ends you will need for a particular width?

A COTTON SKIRT FOR EASTER

I make no apologies for giving yet another version of this kind of thing. I feel that one cannot have too many articles dealing with something that will help us to greet the Spring with a smile, and after all, you may not need it for yourself, in which case you will wish to have a completely different one from your own.

As we are likely to still have something of a nip in the air in April, I think you would be well advised to make the skirt a little thicker than the usual 12/2's warp with the 6/2's coloured weft, so I am proposing that you should use the 12/3's warp cotton, and for the weft one of the medium coloured gimps with yet another colour for the small pattern bands in 6/2's, and the plain rows of contrast can be in the natural gimp.

The warp of 12/3's plain unbleached cotton will take nearly 8 ozs, and the coloured gimp for the main body of the skirt will need about 10 oz, 6/2's merc cotton in a colour to blend or contrast with the gimp will call for roughly 2 ozs, of which, no doubt, you will have some left from another project. Of the natural gimp only about one oz will be needed.

These quantities are for the full gathered skirt, of which we give a picture, but if you are thinking of a straight skirt, with a pleat, or Dior flap at the back then you can reduce the amounts given by at least one quarter.

We used a 10 dent reed, but if you only have a 14 dent, then just adjust the number of warp ends to accommodate one extra end per inch, so that you will have 21 e.p.i. by threading 2 and 1 alternately through the reed. In all cases the pattern is threaded single through the healds.

For the gathered skirt you will require 718 ends to give just under 36 inches of width on the loom, or for the straight skirt it should be 598 ends to give approx 30 inches on the loom. These widths will be a little less when woven, as we all tend to "pull in" a little when weaving, but there will be sufficient for both styles. The warp ends should be $2\frac{1}{2}$ yds long in either width.

The threading draft for the pattern is already set out in this number for the plastic tape mats, so I shall not take up any more space in repeating it. Use this draft and repeat the eight ends of Rosepath until you have just enough ends left for the last selvedge.

Do not, however, use the weaving lifts in that article but refer to the list I shall give now.

Shafts. Pedals.

3 & 4	5	Use these lifts once only
1 & 4	6	No binder need be used with
1 & 2	1	these lifts.
2 & 3	2	

First of all weave in plain weave, with the gimp you have chosen for the body of your skirt, enough for the bottom hem of the skirt; we estimate 6 inches. Now to begin the pattern band. One row nat. gimp, 2 rows coloured gimp, three times. Now the pattern lifts three times, each repeat divided from the next by two rows coloured gimp. Weave five bands using all these repeats, and finish with an extra repeat of the natural and coloured gimps only. This pattern band should measure approx 9 inches, so now weave with the coloured gimp in plain weave until your work is 32" from the very beginning. Throw two rows of a complete contrast to act as a cutting line, and repeat exactly for the other half of the skirt. Put in another cutting line, and then weave the waistband either in plain weave, or you can use the rows of natural and coloured gimp, with just one repeat of the 6/2's pattern and then 2 inches of plain weave for the inside of the band. Remember to weave about 6 rows of plain weave first to allow for the turn up when making the waistband.

Remove from the loom and steam press. Now make up the skirt according to the pattern you have decided upon. For the gathered skirt it is just a matter of turning up the hem and joining the sides, inserting a zip fastener. Then gathering or pleating into the waistband etc. The straight skirt will no doubt need a paper pattern, but the instructions with it will be very clear, I am sure.

The estimated cost for the materials only will be about 12/6d for each skirt, and zipper etc will be covered by another 2/6d. A very inexpensive skirt, and one that will give endless wear.

PLASTIC TAPE MAT

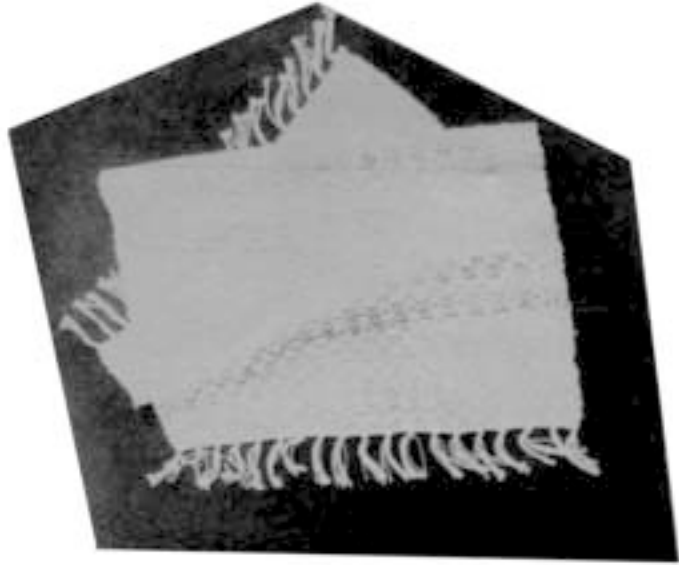

COTTON SKIRT
FOR EASTER

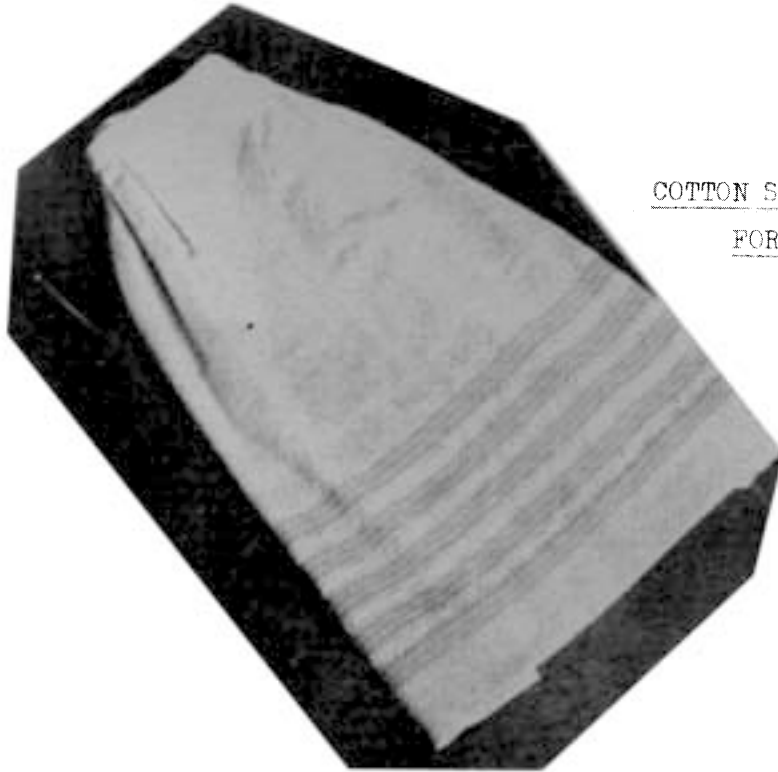

CONTENTS OF THIS ISSUE OF LOOMCRAFT

Volume Three

WINTER 1965

Number 12

Editorial

Head Squares

Cane Mats

Tweed Jerkin

Waffle Weave

- with sample

Plastic Mats

Cotton Skirt

Single copy 1/3d., post free.
5/- per year inc. post.
One Dollar buys 5 issues.

"LOOMCRAFT" is issued
four times a year -
Jan. April July & Oct.