

# LOOMCRAFT



CAMPDEN WEAVERS

Volume 9, No. 1

JANUARY 1977

\* \* \* \* \*

## CONTENTS

Editorial	page 2
Canvas Weave Scarf	3
Bedspreads	4
Curtain Material	5
Spinning Wheel Maintenance	6
What Price Weaving?	7
Classified Advertisements	8
Handweaving Yarns	9
Mailbag	10
Choosing A New Loom	10

\* \* \* \* \*

Subscriptions - £1.10 for 4 issues  
(including postage and packing)

Issued quarterly - January, April, July and October -

CAMPDEN WEAVERS  
16 LOWER HIGH STREET  
CHIPPING CAMPDEN  
GLOUCESTERSHIRE  
ENGLAND

tel: Evesham 840864

Dear Weavers,

Once again I have the pleasurable task of thanking you all for your encouraging comments.

It seems that the clearer printing of "Loomcraft" has been popular amongst our readers, and whilst we were rather ashamed of the bad layout of the October issue (which was unfortunately out of our hands), this issue promises to be much better.

We are very proud to be able to announce that we are now agents for LERVAD looms. These are Danish, and made to a very high standard. We are happy to recommend them and display some in our shop, and we would be pleased to advise anyone who is interested in buying a loom.

A note to those organising exhibitions of weaving and spinning either in England or abroad. We would be very glad to mention these in the magazine (free of charge), provided you can let us have full details well in advance. We get so many enquiries from weavers and other members of the public, that if we can help by passing on information, we should be delighted. If you can also supply us with a poster for display in our shop, or leaflets to hand out, this would be appreciated.

The tremendous upsurge of interest in spinning and weaving seems to be reflected in the number of classes which have started recently. However, for as many classes we hear of, there are more people still who come to us to ask where they can learn about weaving.

Naturally, we try to assist, but mostly all we can do is to put them in touch with Guild secretaries in the various counties. If you would let us know about classes, either privately run or in colleges, then we could put the enquirers in touch more directly. We could also pass on details of Guild meetings to people interested, if secretaries would send us the relevant details. We would like to build up an index of courses and Guild meetings, so wherever you live, from Torquay to Timbuktoo, please tell us about the weaving activities going on in your area.

Once again, I must thank all of you who have given us your continued support.

Happy weaving.

*Jennifer Green*

The scarf pattern I gave in the January 1976 issue of "LOOMCRAFT" seems to have been very popular. We have heard of so many people who have woven this, and I thought that this time I would give a different scarf pattern. This one is in canvas weave which makes an interesting open weave texture. Being lightweight and full of holes, it is lovely and warm to wear, yet uses very little yarn in the actual weaving.

Start by making a warp of 110 ends and  $2\frac{1}{2}$  yards long, using 2/16s pure Shetland wool. This allows sufficient for a scarf of 10 inches wide and 60 inches long, and includes wastage of  $\frac{3}{4}$  yard. If you want to put on enough for 2 scarves, then add another 2 yards, that is  $4\frac{1}{2}$  yards altogether.

The threading is as follows:

3 3 2 2	4 3 3 2 2 1	3 3 2 2	4 3 2 1
selvedge	pattern repeat 6 threads	selvedge	shafts

#### Analysis of threads

Selvedge	4
Pattern 6 threads, 17 times	102
Selvedge	<u>4</u>
	110
	<u><u>        </u></u>

Sley a 10 dent reed as follows:

Selvedge: 2 ends per dent  
 Pattern: 3 ends through 1 dent  
           miss 2 dents  
           3 ends through next dent  
           miss 2 dents  
                           continue thus to other selvedge  
 Selvedge: 2 ends per dent

Using the same wool for the weft as for the warp, weave a border of plain weave (1 & 3, 2 & 4) for 1 inch. Then start the canvas weave pattern, where the weft threads are laid in two groups with a space between, to give the open weave effect. The alternate groups of weft lifts are as follows:

1 & 3	2 & 4
1 & 2	3 & 4
1 & 3	2 & 4

The warp must be kept stretched fairly tightly while weaving, as the grouping of the weft threads is only possible under this condition. Throw 3 picks of weft, and then lightly beat into position together. Then throw the next group of 3 weft picks, and again beat lightly into position, leaving a space between the groups, say about  $\frac{1}{4}$  inch. After weaving 3 inches, weave another 1 inch of plain weave, then continue with canvas weave for 50 inches, and finish with 1 inch plain weave, 3 inches canvas weave and 1 inch plain weave.

Take it off the loom and finish each end with a fringe, knotting together 4 threads for the selvedges and in groups of 3 threads right across.

Some weavers would like to weave bedspreads and perhaps curtains to match, and the problem is always the width of the bed and the width obtainable on a loom. So this is what I have found very successful, and I have used up all those odd two ounces, one ounce, etc., which every weaver collects inevitably. Is my odd bits drawer empty - no! Is yours?

Decide on the width of required bedspread, then treble it or multiply by four, and that is the length of your warp (plus wastage of course). The length of bed and tuck in required will be determined by how many inches your loom can weave (never never set up a loom full width - one inch on both ends is minimum safety).

Choose a colour scheme or use the odd bits in a carefully planned sequence, and by now you will have realized that the joins selvedge to selvedge (so easy to sew strongly) are going to be across the bed. The joins will not show and the repetition of, shall we say, that inch of blue will be in the three or four widths, and so make its own pattern in colours. Use very small stripes no wider than an inch, and keep on varying width of stripes.

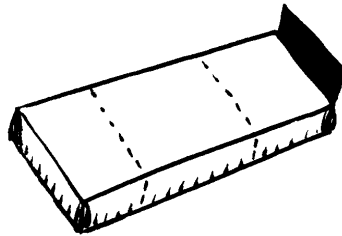

Weft - one yarn only. I find a cream or white gimp absolutely right, and the gimp blurs the stripes slightly.

Tabby threading (4,3,2,1) and a Twill treadling (1&2, 2&3, 3&4, 4&1). Start by a double thread through No. 2 shaft and finish with a double thread through No. 3 shaft, and a perfect selvedge is obtained if twill is sloping to the left. I used a 14 dent reed, set at 21 ends per inch. As I used up a few slub yarns I dared not do 24 per inch.

I used a single fine silver supported by another thread very occasionally, and the effect at night is a tiny bit luxurious. My warp was all shades of mauve, purple, hedgesparrow blue, grey, fawn and grassy green; the eiderdowns are turquoise/hedgesparrow, and carpet plain mauve. I wove a quick spaced lampshade to match, and a mauve corner washbasin completes my spare room, with violets on the morning tea-tray. And then the irony is - I haven't time for visitors!

CURTAIN MATERIAL

by Evelyn Green

Recently I went to a very interesting lecture on Craftsmanship by Sir Gordon Russell, the well-known furniture designer in Broadway, Worcestershire. Afterwards we were allowed to look round his showrooms and saw some of the magnificent furniture made there. I was particularly interested in the curtain materials displayed as a background to the furniture, and on looking closely at these, was struck by the lovely texture effects that were obtained just by using plain weave and varying the colours and textures of the yarns. They seemed to blend in so beautifully with the setting.



All this inspired me to make some curtain material. The sample piece this time is 24 inches wide so that it can also be woven by those with table looms, and wider curtains can be made by weaving double the length of fabric and neatly joining down the centre of each curtain.

Make a warp of 517 ends and 4 yards long, using natural unbleached cotton 10/2s and red cotton 2/14s. The order of warping is: 1 red, 6 natural, 1 red, 6 natural, repeated right across the warp.

The threading is as follows:

4	4 4 4 4 4 4 4 4 4	4	4	4	4
3	3 3 3 3 3 3			3	3
2		2 2	2 2	2 2	
1	1 1 1 1 1 1 1 1 1				1
selvedge	pattern repeat	34 threads		selvedge	shafts

Analysis of threads

Selvedge	3
Pattern 34 threads, 15 times	510
Selvedge	<u>4</u>
	<u>517</u>

Sley a 14 dent reed with 2 ends per dent for the selvedges and 2, 1, 2, 1, right across between selvedges.

The weaving is a variation of Swedish Lace pattern, and the lifts are as follows:-

2 & 4  
1  
2 & 4  
1  
2 & 4  
1 & 3  
4  
1 & 3  
4  
1 & 3

Either you can use the 10/2s natural unbleached cotton for the weft, or for a much more colourful effect, the red 2/14s, as used in the warp. For a stiffer fabric, use 16 lea rough spun flax, as I have

done in the sample piece. This linen thread gives it 'body', and it would make an ideal material for tablecloths, table mats or lampshades. Alternatively, how about using it for a wall covering?

The finished length of this piece of weaving was  $3\frac{1}{4}$  yards, and for this the quantities of yarn used were: for the warp, natural unbleached 10/2s cotton - 8 oz., red cotton 2/14s - 2 oz. The weft required about  $\frac{3}{4}$  lb. of either cotton, or the 16 lea rough spun flax.

Although it is perhaps more interesting to weave a pattern, for those of you with tabby looms don't feel downhearted, because this material done in plain weave and using different thicknesses of cottons in the warp for texture effect, would look most attractive.

\* \* \* \* \*

### SPINNING WHEEL MAINTENANCE

by J.A.N. Burra

(Mr. Burra is a craftsman who makes spinning wheels, and though these notes were written with his own spinning wheels in mind, they can also be applied to most other types of wheels.)

#### Storage

- (1) Keep, and especially store, the wheel away from heat sources such as radiators, hot pipes, fires and the sun.

#### Oiling

- (2) Neatsfoot oil, obtainable from saddlers, is ideal.
  - (a) Occasionally oil the wheel bearings, each end of the pedal bar, and the footman including the leather thong at its lower end.
  - (b) Oil each end of the spindle where it enters the leather bearings, fairly frequently.

#### The Bobbin

- (3) Make sure that the bobbin spins absolutely freely on the spindle each time the bobbin is changed or when starting to spin after a period when the wheel has not been in use. We do not recommend the use of oil on the bobbin or the bobbin spindle section, as wood tends to swell when oiled. Buy a round,  $\frac{1}{4}$  inch diameter, fairly coarse file and keep this handy. Bobbins which are not spinning freely can be cleared of dust and accumulated wool and lanoline by a few file strokes in the bobbin bore. Clean the spindle occasionally with Methylated or Surgical spirits. When the spindle is replaced, see that the flange on the spindle is not pressed too tightly against the leather bearing with the large hole, or the spindle and flyer will not rotate really freely.

#### The Driving Band

- (4) There is nothing very special about the type of string or cord used despite widely held views as to which is best. On single band wheels where no slip is required, a thicker band, giving better grip, may be preferable. The driving band will stretch in use.

#### Polishing

- (5) Use any good furniture polish.

\* \* \* \* \*

It is when weavers come to want to sell their work that the problem of what to charge presents itself. Despite the title of this article, there are no hard and fast rules for doing this, but I hope that it may give you some clues on how to decide what to ask for your work.

The first clue, and perhaps the only one that can be worked out fairly accurately, is the cost of the materials used. However, even this may be a stumbling block. It is easy to say that you were only using up odds and ends, or that you bought the yarn so long ago that you can't remember what it cost. However, yarn these days, unless you are very lucky, does not grow on trees! So for your first thought, I would say, work out the cost of your materials as if you were buying them new to-day. After all, if you want to weave more of a certain article and you have run out of odds and ends, then you will have to buy more, so that the cost of replacement materials must be bargained for.

After that, the problem is much more difficult. There is no set formula like: treble the cost of your materials or charge so much per hour for all the work you put in towards weaving whatever it is. Indeed, how can one put a value on time?

Obviously you, as a weaver, want to make as much money as you can. If you price your work too low, then it may sell very quickly, with other orders following, thus leaving you with the possibly enviable, but nerve-wracking task, of always struggling to keep up with demand, with hardly any profit to show at the end of it all. Alternatively, if the price is too high, you will be left with all the articles still on your hands, and no money at all.

Another clue to prices is to try and find out the price of comparable articles. Bear in mind when looking, that, especially if your weaving is good, you may have a unique article. Some people still think that if an article is handmade it should be cheap, but nowadays (despite some of the rude comments we get from people looking round our shop!) people are prepared to pay fairly high prices for something of good quality which they really want. However, if you want to command a high price, then your article must be really well made, well finished and preferably unique. If the customer can buy a similar machine-made article down the road for half the price, then believe me he will!

If you are selling through a retail shop, first of all get it clear on what terms your work is being accepted. If the retailer intends to take a percentage of what you have asked, then you may end up with less money than you thought! We prefer to ask the weavers we deal with what they would like for their work and then add our percentage on top of that, as we think this is a fairer way of doing business. A retailer after all is not going to sell your

work for nothing, as he has his overheads to pay, in return for giving you the chance of a shop window for your work.

Probably he will also be able to advise on what sort of price he can obtain for your work in his particular area. So take his advice, but don't let him beat you down too low! Remember he may only be interested in a quick turnover, but on the other hand, the higher the price he can get, the greater percentage profit he will make.

In conclusion, the only real advice I can give on pricing your work is to find out who you are selling to, and what they will be prepared to pay. After all, it is to all intents and purposes, a game that is played by trial and error, and the more you play it, the less rules there seem to be!

\* \* \* \* \*

#### CLASSIFIED ADVERTISEMENTS

We should be pleased to receive your advertisements for Sales & Wants.

The charge for this is 2p per word.

SPINNING & WEAVING COURSES for beginners.  
Week-end or full week. Tuition and accommodation in historic 15th century Priory, Suffolk. Log fires, central heating, home cooking. 5 acres quiet garden. Maximum number taken 4, so almost individual tuition. Courses run through January to December. Brochure on application to Wingfield Priory, Wingfield, Suffolk.  
Telephone: (037-984) 409.

FOR SALE - 3 only. Craftsman made Norwegian type spinning wheels. New. Beautiful and functional. £60.00.  
Telephone: Stradbroke (037-984) 409.

WANTED - (by Campden Weavers) More articles on relevant subjects to print in "Loomcraft". Remember, there's a year's subscription free if we include your article in the magazine.

ALSO - more good quality handwoven and/or handspun articles for sale in our shop. Either call in personally, or send details of your work.



## HANDWEAVING YARNS

We keep on being asked for warp yarn suitable for scarves, and we now have in stock some lovely soft 2/16s Shetland wool, which would be ideal for this purpose. It comes in natural white only, but would dye very well, and is priced at £2.24 per lb (plus postage and packing).

Slightly thicker and harder is the 2/7s fawn wool, which would be ideal as a warp for handspun yarn. This is also £2.24 per lb (plus postage and packing).

### Yarns mentioned in this issue of "Loomcraft".

10/2s natural cotton (CW 2/1) @ £1.76 per lb

2/14s red cotton @ £1.76 per lb

16 lea linen (CH 5/14) on 2-3 lb cops only  
@ 96p per lb

White cotton gimp (CW 2/6) @ £1.76 per lb

(Postage and packing charges are extra to all the above prices)

Samples of the above mentioned yarns are available, but please enclose a stamped addressed envelope (or two International Reply Coupons) with all enquiries.

### NEW IN STOCK

With the popularity of bead weaving growing, as well as stocking bead loom kits, we now have the replacement beads for these also, in a variety of colours. They come in small plastic boxes containing approx.  $\frac{1}{2}$  oz. of beads in one colour or a mixed selection. They are priced at 19p per box (plus postage and packing).

We did mention in the last issue of "Loomcraft" about having some 3-holed triangular tablets made. Unfortunately, the holes in these were punched rather out of line, so we are selling them off at 50p for 25 tablets (plus postage and packing). Please send a stamped addressed envelope if you would like to see a sample of them.

We now have some small wooden tapestry bobbins in stock. These are hand made locally and are 25p each (plus postage and packing).

Jacob sheep are a very popular breed of sheep at the moment, and we have some postcards of these sheep in 4 different designs: photographs of a Jacob lamb, a Jacob ram, and a group of Jacob sheep, plus a painting of a Jacob ram. These are 8p each (please enclose a stamped addressed envelope if ordering these separately).

We do produce a price list of our equipment as well as a list of the books we have in stock, and would be pleased to send these to anyone who requests them, but please enclose a stamped addressed envelope or 2 International Reply Coupons.

Mrs. Georgina Lloyd of Whangamata, New Zealand, has been kind enough to tell us about the spinning and weaving going on near her. "Weaving and Spinning are quite the craze here. We have our own little group in this little town and next month (November) we are having our Spin-in, inviting the Waihi branch en bloc to join us. We have a craft shop, open in the Christmas long summer holidays and any other special holiday weekend, where we can sell our various articles - my speciality is sets of luncheon mats of which I never seem to be able to keep up a supply. . . The top N.Z. weavers do really beautiful work and each biggish town has an exhibition during the year. We try to see as many as we can, as the good work is such a spur. New Zealanders think nothing of going many miles over the country to see top work, and everybody so very keen. As for friendliness we never found anywhere to beat it. We find great kindness all round us. It is lovely to live in it and be accepted as part of it all. Are we not lucky!"

Whilst on holiday in Brittany, Mrs. Rosemary Martel of the Channel Islands "came across an old village where there was linen weaving done - Locronan (Finistere) - marvellous fine work. I wanted to buy some balls of linen thread, but they only sold the finished article. But alas the looms were not being worked at the time."

The Multiple Sclerosis Society has a keen supporter in Mr. A.S. Dolden of Essex, who does all his weaving to raise funds for them "and up to the present (September) we have raised £108 this year, mainly from the sale of shoulder bags and fine wool long scarves and evening stoles, and now feel we need a new line for the coming Christmas trade. We just deduct the cost of materials from a realistic price, although we are always being told we are too cheap, and the rest goes to the M.S. Society."

Last, but by no means least, Mrs. D. Moody of South Australia wrote us the following message: "What a universal door-opener spinning and weaving is. It just seems natural to talk to strangers doing craft work". I am sure a lot of other people feel like this, judging from the friendly craftsmen who visit our shop, and we are grateful to Mrs. Moody for putting this feeling into words.

\* \* \* \* \*

CHOOSING A NEW LOOM (1)

by Nanna Dons Jensen

(Teacher and weaving adviser to  
Anders Lervad & Sons, Denmark)

I am so pleased to see that at long last weaving is beginning to attract the attention of interest in Britain that this, one of the finest crafts there is, deserves. In my country, Denmark, it has always been a popular craft and there are almost as many hand weavers in Denmark as there are hand knitters and even small children are taught the rudiments of the craft on their own simplified looms.

My company has specialised in the manufacture of weaving looms since 1895, when my great grandfather, himself a master craftsman, established the firm. Today we make looms for all kinds of weavers, from the professional designer to the absolute beginner. We try to bear all their different needs in mind.

Buying a new loom is for most weavers a very exciting proposition, entered into only after some thought and consideration. If you already own your own loom the new one will perhaps be chosen because it is a specialised loom for say, tapestry weaving, or some other specific area of the craft. Or perhaps you just need a larger and more versatile loom for ambitious projects.

This article is really intended for the first-time loom buyer, who has perhaps gained some proficiency at the craft at a weaving course or school and has now decided to purchase a loom of her own.

Looms, as you will know, vary enormously in size and scope from the simplest weaving frame to the most complex multi-shaft loom - and they also vary in price! Size, capacity and price all need to be considered very carefully.

### Table looms

These are frequently the cheapest type of loom and often operate on simpler systems. But some are more versatile than others. The obvious thing to point out is that progress on a non-treadle loom is relatively slow which may prove irritating if you intend to weave larger items. As these looms are usually quite small the weaving width may also be a limiting factor unless of course you intend to specialise in small intricate items.

It is well to note at this point that some manufacturers state merely the width i.e. external dimension of the loom, or sometimes the internal width. Although both these statistics may be required you should also determine the actual weaving width, which is the size of reed, and therefore the width of fabric, the loom can accommodate. A width of about 80 cms. provides a width suitable for the production of fabrics for various purposes, such as making into clothing or furnishings, etc., but one of 60 cms. may be adequate.

The versatility of the loom is directly related to the number of shafts it has and although a simple two-way loom permits endless permutations of colour and finger manipulated designs within the confines of plain weave, a four or six shaft loom provides far more. It is sensible when buying your first loom to think ahead and ensure that you won't outgrow its limitations within a short while. Not only the number of shafts but also the way they operate has a bearing on the quality of weaving you will be able to produce.

The best table looms create a double shed every time the shafts are moved. What is described as a double shed looks like this

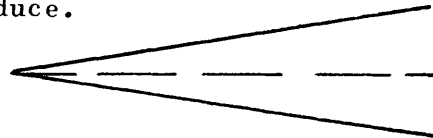

from the side. It happens because at the formation of each and every shed all the warps move either up or down at an equal angle. This means that equal tension is exerted on all the warps, the weave is more even and there is far less likelihood of any threads breaking.

In many small table looms the shed is formed by raising or lowering one set of warps while the rest remain stationary. Those which create a double shed are preferable if perhaps a little more costly. A loom of this type is the Lervad loom No. 13. Here the shafts are operated by handles at the top of the loom which move between their upper and lower positions so that no warp ever remains stationary. This loom can also be provided with a folding base if this is required.

(Part 2 "Treadle looms" cont. in April issue)



# LERVAD

## now available from CAMPDEN WEAVERS

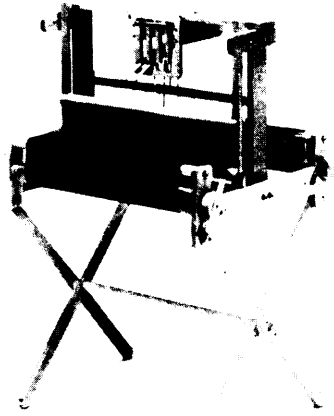

### LOOM NO. 13

is a compact table loom of a practical size for homeweaving projects and for occupational therapy. It has four harnesses operated individually by handles and is therefore very suitable for use by beginners and the handicapped. Loom No. 13 has no treadles or complicated tie-up system to be mastered. The loom is provided with an overslung beater, which is easier to work with than an underslung beater. Breast and back bars ensure that the warp is maintained at a

constant level howeverlong the warp. As an optional extra the loom may be supplied with a base No. 226/1 which is adjustable in height. Loom No. 13 is accurately made of kiln-dried Danish beech and is lacquer finished. Axle points in the beams and ratchet wheels are of steel. Heddles No. 243 and reed No. 264 should be used in a weaving width of 60 cms.

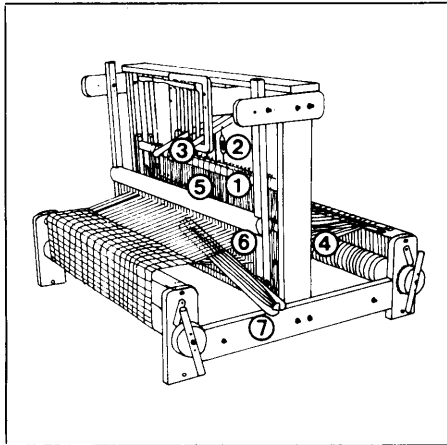

### Tie-up System

Loom No. 13 has four harnesses (1) guided by grooves in the sides of the loom. Each harness is connected to a handle (3) by a wire connector. The warp threads (4) are threaded through the heddles (5) placed on the harnesses. By moving the handles into their upper and lower positions the shed (7) is created, through which the shuttle (8) holding the weft thread is passed.

Unlike most table looms of this size, Loom No. 13 has a double shed because the handles, and therefore the harnesses, are always moved either up or down. The wire connector provide the advantage of adjusting the size of shed according to the flexibility of the warp material. Loom No. 13 is simple for beginners to use as it is wholly manually operated. The loom has no treadles and consequently no complicated tie-up is required. The setting-up and working of the loom are explained step by step in the illustrated manual provided.

### Specifications and measurements:

4 harnesses and 60 cm weaving width.  
Order No. for base: No. 226/1.  
External measurements: Width 780 mm (30 1/2"),  
depth 700 mm (27 1/2"),  
and height 630 mm (25").

### Accessories included:

Loom No. 13 is available with different sets of accessories to cater for the varying requirements of home-weavers and institutions.

**Order No. 226:** 2 cross sticks, 2 beam sticks, 12 warp sticks, 2 stick shuttles No. 260 C, 1 ball of tie-up cord No. 274, 1 manual.

**Order No. 226A:** In addition to items listed above: 500 heddles No. 243, 1 reed No. 264, dentage 40/10 - 60 cm, 1 threading hook No. 266, 1 reed hook No. 267.

**Order No. 226B:** In addition to items listed above and under »A»: 6 warping posts No. 272, 1 swift No. 276, 1 temple No. 265B, 1 base No. 226/1. This list includes all accessories used with the weaving example in the manual.

ANDERS LERVAD & SØN A/S · ASKOV · DK 6600 VEJEN · DENMARK

# LOOMCRAFT



CAMPDEN WEAVERS

Volume 9, No. 2

APRIL 1977

\* \* \* \* \*

## CONTENTS

Editorial	page 2
Choosing A New Loom	3
Those Things That Ought To Match	4
Evening Skirt In Cotton	5
Sample Piece	7
When The Bug Bites	8
Mailbag	9
Books	10
Guild News	11
Yarns	11

\* \* \* \* \*

Subscriptions - £1.10 for 4 issues  
(including postage and packing)

Issued quarterly - January, April, July and October

CAMPDEN WEAVERS  
16 LOWER HIGH STREET  
CHIPPING CAMPDEN  
GLOUCESTERSHIRE  
ENGLAND

Tel: Evesham 840864

Dear Weavers,

"Loomcraft" is now bigger and better - at least we think so and, judging by the letters we have received, many of you agree with us. Both the typing and the printing of the last issue were good, and we were rather proud of sending it out. However we should like to point out that as we now have printer's deadlines to meet, copy for inclusion in the magazine must reach us at least six weeks before publication.

We are delighted that some of you are now sending us such interesting articles. It is so nice to be able to reflect different points of view on weaving and spinning. I think this is especially brought out by the two articles in this issue which discuss looms. Nanna Dons Jensen brings out many of the points which go to make up the ideal loom, while Ted Rogers has used a combination of bedsteads and broomhandles to make one of his own needing very little outlay. I am sure that most of our readers, like me, will have some sympathy towards both points of view. By the way, if any other readers have any good ideas or tips which they use, please don't keep them bottled up, but think about sharing them with some of your fellow craftsmen.

During the winter months when things were quieter in the shop, we were able to find time to get down to some serious weaving, to try and replenish our sadly depleted stock. I have been weaving numerous lightweight scarves as these seem to be popular, using the lovely 2/16 Shetland wool warp, with various coloured looped yarns for weft. I also tried the 2/7 fawn wool warp, and though these came out slightly heavier in weight, they were great fun to weave. I must admit that I am rather proud of them, and I only hope our customers will agree!

Among other things, we also found time to put up our new Lervad looms. They are certainly very well constructed and should stand up to all the hard work they are likely to have to take, as well as being attractive to look at. The folding floor loom and the table loom (advertised in the January issue of "Loomcraft") are now on show in our shop, so if you get the chance, do come and see them.

We were so pleased to meet all the "Loomcraft" subscribers who came to visit our shop last year, and we hope to see many of them again, together with some new faces. Please do introduce yourself as a "Loomcraft" subscriber if you come, as it is so nice for us to be able to picture the people to whom we send the magazine. Our opening hours are from 9.00 am-1.00pm, 2.00pm-5.30pm (Monday to Saturday inclusive) and early closing is on Thursday.

Anyway, until we meet again, either in person or in the July issue of "Loomcraft", best wishes and happy weaving.

*Jennifer Green*

Treadle Looms

These are often, but not always, larger looms with multiple shafts. Obviously progress is much faster with your feet to help you along. Here, unless you have premises designed to accommodate a weaving loom, size will probably be an important consideration. If space really is limited there are several looms available which will fold up with warp on and occupy very little space. The Lervad loom no. 9 is one such. Again, the number of shafts will determine the variety of weaves at your disposal.

If you decide on a fairly large loom and intend to weave very long fabrics, it is advisable to select one with both breast and back bars, and possibly a knee bar too. These are desirable because when working with long warps, which must be wound round the warp and cloth beams many times, the threads tend to slip down between each other. When you are dealing with a warp diameter of perhaps several inches this means that the warps are distorted and stretched, which creates an imperfect weave. Breast and back bars ensure that the warp is kept level, whatever its length.

A system less well known here than it is in Denmark is the countermarch system, which is a refinement to be appreciated.

The countermarch system works by means of jacks (which raise the shafts), short lamms and long lamms, which are connected via each other to the treadles.

Basically it means that if a treadle is depressed, a sequence is set in motion whereby the shafts attached to that treadle are raised and all others lowered. This provides even and accurate sheds which may be adjusted for different tensions of warp material. Any number of shafts can be made to operate independently, or in partnership, by the countermarch system.

An alternative system is the counterbalance shaft operation. On a counterbalance loom, shafts are literally balanced against each other in pairs. When one is raised, its opposite number is automatically lowered. Although a sound system for looms with two shafts, this is not nearly as efficient as the countermarch system for multi-shaft looms. A major disadvantage of the counterbalance system is that the shafts must operate in pairs, which limits the number of patterns available to the weaver. If each shaft works independently, and can be used in conjunction with any other, the loom is that much more versatile.

Other things to look for

To produce an even weave the loom must work smoothly. To this end, check that all the moving parts move freely and easily - and quietly. Looms operating by wires and chains, although just as efficient as those operated by cords, tend sometimes to be a bit noisy. Check also that the loom is made of sound timber; a good loom should be made of hard wood, which has been treated so that it will not warp or distort. A jerky action is very likely to break warp threads and prove unsatisfactory. All metal parts, such as axle points should be made of some rust resistant material as these too

can cause problems. Heddles and tie-up cords are sometimes made of steel and sometimes of cotton, which besides giving a quieter performance, are kinder to the warp threads which pass through them. The beater on some looms is mounted at the top of the loom and on others beneath the level of the warp. I think that the former arrangement is easier to work with.

### Accessories

This is another vexed question for the weaver who possesses no weaving equipment already. She will see listed as accessories in manufacturers catalogues a great number of items, some of which are absolutely essential to make the loom operable and others which are really optional extras. Provided with most looms will be shuttles of one type or another, tie-up cord, beam sticks. You will of course need heddles, and the number required depends on the width of the loom. The size of heddle depends on the warp you use. Additional reeds will also be required according to the warp material. Threading and reed hooks are also very useful, though substitutes can be devised.

Other accessories such as a warping frame, swift, mill, etc. raddles and temple make weaving a lot easier, but may be purchased at a later date.

\* \* \* \* \*

### THOSE THINGS THAT OUGHT TO MATCH

by Vera Miles

When weaving say skirts, curtains or chairbacks with borders on the bottom, they should match, to be sewn selvedge to selvedge. However much one puts on to paper in directions, when the first border is hidden (rolled round the cloth beam), it may not be exactly matching in depth, because of sometimes several days interval in weaving, or a firmer or less firm beat according to mood.

Here is what I find helps. Weave the first curtain from top to bottom - border visible. Then weave the second from bottom to top, and one is weaving the second border while the first is still visible gradually going down. So if say 20 throws of brown makes one inch in the first and only 19 throws make one inch in the second, leave it at 19.

One of the biggest 'hit and miss' in our craft is getting the consistent perfect tension in warp and beat.

\* \* \* \* \*

### ANY OLD SHOES?

One of our readers, Mair Davies of Dyfed, Wales, was thrilled to see a report of the demonstration she had given to a local Women's Institute written up in the local paper, but not so pleased when it described how she used hedgerow materials such as foxgloves, "shoes" and tree bark for her dyeing. "Were they sling-backed, stiletto heels or my well worn lumpy walking shoes?" she asked. "The mind boggles, but alas now, it should have read 'sloes', which my youngest daughter picked for me fondly believing she was gathering damsons for damson jam."



A cotton evening skirt may sound a little chilly for winter weather, but most folk go to their various functions by car; also the halls and such like are normally heated, so I don't think one would be cold.

The pattern I am giving could also be used for many other things such as runners, table mats, trolley cloths, cushion covers, short skirts or even a dress. Bears thinking about!

For the long skirt, the pattern bands could be separated by a few picks of plain weave and worked in various colours in different shaft lifts, to give a total depth of as many inches as you wish; also by using various colours, some of those accumulated oddments could be used to very good advantage. You need not necessarily use mercerised cotton, which I suggest, for the main part of the skirt, but any other suitable yarn you may have by you, but the suggested yarn is 12/2's mercerised cotton for warp and weft, and 6/2's mercerised cotton for the pattern work.

For a width of about 30" when finished you will need 881 threads sleyed double through a 14 dent reed; this will be about 32" in the reed. The length of the warp depends on your requirements. Make your warp in 12/2's mercerised cotton using a neutral colour such as unbleached, light grey, biscuit or brown if you have enough colours that would show up well.

Having made your warp and threaded your reed double, the healds are threaded singly throughout in the following draft:

4    4 4 4 4    4 3 3    3    3    3    3 3 3 2 2 2 2 2 2    2 2 2 2 2 1    1 1 1 1 1 1 1    1	4    4 3    3 2    2 1    1
pattern 36 ends	selvedge
selvedge	balance

Analysis of threads

Selvedge	8
Pattern 36 ends	
repeated 24 times	864
Balance	1
Selvedge	8
	-----
	881
	=====

When all is ready for weaving the shaft lifts are as under, and a binder thread follows each pattern pick. This would look very nice in Lurex, but failing that, use a fine yarn, the same as the warp or finer.

## Shaft Lifts

<u>Shafts</u>	<u>Pedals</u>	<u>Times</u>
---------------	---------------	--------------

### PATTERN No. 1

1 & 2	1	1
1 & 4	6	1
3 & 4	5	1
2 & 3	2	1
1 & 2	1	1
1 & 4	6	3
3 & 4	5	2
2 & 3	2	2
3 & 4	5	2
1 & 4	6	3
1 & 2	1	1
2 & 3	2	1
3 & 4	5	1
1 & 4	6	1
1 & 2	1	1

### PATTERN No. 2

4 & 1	6	1
1 & 2	1	1
2 & 3	2	1
3 & 4	5	1
1 & 4	6	1
1 & 2	1	1
2 & 3	2	1
3 & 4	5	2
2 & 3	2	2
3 & 4	5	2
2 & 3	2	1
1 & 2	1	1
1 & 4	6	1
3 & 4	5	1
2 & 3	2	1
1 & 2	1	1
4 & 1	6	1

### PATTERN No. 3

4 & 1	6	1
3 & 4	5	1
2 & 3	2	1
1 & 2	1	1
1 & 4	6	1
3 & 4	5	2
1 & 4	6	1
1 & 2	1	1
2 & 3	2	1
3 & 4	5	1
1 & 4	6	1

<u>Shafts</u>	<u>Pedals</u>	<u>Times</u>
---------------	---------------	--------------

### PATTERN No. 4

1 & 4	6	1
3 & 4	5	2
2 & 3	2	3
1 & 2	1	4
2 & 3	2	3
3 & 4	5	2
1 & 4	6	1

### PATTERN No. 5

1 & 4	6	2
3 & 4	5	2
2 & 3	2	4
3 & 4	5	2
1 & 4	6	2

Patterns Nos. 1, 2 and 3 can be repeated if deeper bands are required, but I think narrow ones using as many different colours as possible would be very attractive. Anyway, you can really go to town with colour blending.

For weaving first work about 8" for a hem and plain border using 12/2's mercerised cotton the same as the warp, and then work your pattern bands, not forgetting the binder, in 6/2's mercerised cotton for as deep as required, separating them with a few picks of plain weave same as the warp. Then work in plain weave for the length of your skirt. This will complete one side, or rather front, so work another piece in exactly the same way for the back.

DO EXPERIMENT with the shaft lifts as you can so easily get different patterns by changing the number of lifts and by using only part of a sequence, and the more different ones you have, the better.

I hope you will enjoy doing something in this pattern, even if it isn't a skirt, as it is very attractive. From the sublime to the ridiculous, pincushions look very good, I've done some!



Someone came into the shop recently wearing a very attractive cape, obviously woven with a space dyed, looped yarn. This inspired me to weave something like this for the sample piece this time, as we have a number of such boucle yarns in stock at the moment. It would be ideal material for a skirt and matching waistcoat, or how about an evening skirt and a stole woven with the same boucle yarn? Another possibility would be to use it for upholstery material, say, for a fireside chair.

Below I give details of this in note form. I have chosen to do it this way for two reasons: first of all I thought it might be easier for readers to follow; and secondly, to help those beginners who are uncertain about how to keep records of their weaving. This might act as a guide as to how it can be done fairly simply, and what information can be included, so that if required the work can be repeated at a later date.

Length of warp: 4 yards  
 Width of warp: 31 inches  
 Finished size - before milling:  $3\frac{1}{2}$  yards x 29 inches  
   after milling:  $3\frac{1}{4}$  yards x 27 inches  
 Reed: 10 dents per inch  
 Ends per inch: 15 (sleyed 2, 1, 2, 1, etc. in the reed)  
 Total number of ends: 464  
 Threading: straight entry (1, 2, 3, 4, etc.)

Materials:

Warp: 1 lb. brown wool twist (CW 5/3)  
 Weft:  $\frac{3}{4}$  lb. 15 cut Scottish homespun (bracken) (CH 4/1)  
        $\frac{1}{4}$  lbs. green/pink looped wool yarn (CW 4/2)

Pattern: Shaft lifts as follows:

1 & 3	}	homespun	
2 & 4			
1		looped yarn	
1 & 3	}	homespun	
2 & 4			
2		looped yarn	repeat for required length
1 & 3	}	homespun	
2 & 4			
3		looped yarn	
1 & 3	}	homespun	
2 & 4			
4		looped yarn	

As well as the above, you might like to note the date started and finished, and the approximate number of hours taken to weave the article; also the cost of materials used.

This is my suggestion. Perhaps other readers have different ways of keeping records?

(Mr. Rogers, who is Vice-Chairman of the West Sussex Guild of Weavers, Spinners & Dyers, has chosen a pun on the word 'aware' as the underlying theme of this article)

My story starts to unfold as my teenage daughter is persuading the rest of the family that a holiday in Bronte Country would benefit all - be 'awarer'.

From that visit in 1973 my interest in weaving began, first with a look at power weaving in Haworth, then handloom weaving at Grewelthorpe. By the time we returned home, the effect of this was such that I had decided weaving was definitely for me.

After joining the West Sussex Guild and subscribing to various journals to obtain information, the next thing was to possess a loom. The first of these was an Inkle loom - result: ties, ties, and more ties - at least that is what they started out to be.

Having been told that all serious weavers would eventually want to progress to something larger, I found I was no exception and, if you will pardon the expression, two large problems 'loomed up'. First: Finance. Second: Space. It was decided to tackle both together starting right at the bottom to build. Secondhand timber, some nails and a strong right arm eventually resulted in a shed in the garden, large enough for work, now called 'The Studio', though I sometimes think 'shed' would be more in keeping with weaving.

By this time I had read several books on weaving and knew what I wanted in the way of a loom: 30" floor, 4 shafts, 6 pedals, with overslung batten. The head and foot of a single bed served as a basis. Secondhand timber, including broom handles for rollers, was found, scrounged or ???

By this time it was February 1974 and cold weather. Therefore the first objective was a length of cloth for a new dressing gown (still in use) and so at this point, nine months after the bug had bitten, I was 'a wearer'.

From this, progress was made with scarves, cushions, curtains, dresses, skirts and even new covers for a 3-piece suite.

(But the masterpiece was yet to come and Part 2 of this article, in the July issue, tells the story of what happened to the multicoloured piece of cloth, and how to make one of your own.)

\* \* \* \* \*

SEW WHAT?

On a quiet day last winter, we were both weaving away quite happily on foot looms, one at either end of the shop. We had to stop when a lady came in wanting something-or-other which we didn't have. However she left us with these parting words: "Sorry I disturbed you. Sorry I stopped your sewing"!

We were very interested to hear about some remarkable 16th century Flemish tapestries, which have recently been on show in America. They depict "The Story of Jacob", and because they have been moved very little since they were woven, they are in remarkably good condition. Bridget Anderton, who is a student of tapestry conservation in San Francisco, writes: "The colours are practically intact and the series is complete. Usually one sees tapestries one at a time, because they have been separated during history. In fact, there are series intact and they should be seen hanging border to border for full impact. The Belgians hang theirs flat on the walls with the help of Velcro on top and down the sides. This relieves some of the tension on the weft. We are going to use this system eventually. Now ours hang just from top - which means the top of the tapestries are awfully worn"

It seems that there is a lot of active spinning and weaving going on in New Zealand. "At the end of March we had our National Woolcraft Festival in Nelson", writes Margaret Wanstall. "Lots of interesting workshops, and I took a 3 hour one on Inkle weaving, another on spinning fibres (camel, alpaca, etc.) and a three day course on weaving with linen, flax and wool. Our spinning group (42 members) "The Mapua Woolgatherers" and "The Mapua Weavers" (12 members) had been busy blocking linen tea towels (600) with our spinning lady as the feature, to make funds for our own group and sell at the festival. We are a country group about 20 miles from the city; some of us have our own sheep - I have 10 coloured ranging from a lovely oatmeal colour, light browns and greys".

"Our Exhibition of Local Art and Crafts which we (The Art Group) held during Drumnadrochit Festival last August, was a great success", writes Rosamund MacLennan from Scotland, "and aroused quite a lot of interest among the tourists and summer holidaymakers. We had demonstrations of Table Loom Weaving, Spinning, Doll and Soft Toymaking, Corn Dollies and Macrame. I did the spinning demonstration, spinning Shetland fleece in the morning, and Jacob (spun 'random') in the afternoon. I also showed samples of yarn and fleece dyed with local lichens. It was an awful lot of work for just one day, but it was great fun and realised a very worthwhile sum for our Group funds."

If any of our readers happen to find themselves driving along the road between Pershore and Worcester, they might like to look out for "a beautiful stained glass window of a spinster sitting at her wheel in the east window of Stoulton Parish Church". Vera Miles of Kempsey, near Worcester, tells us that it "is in memory of Mrs. M. Chater whose father was vicar of St. Helens Church, centre of Worcester, now the City Records Office. The window was caused to be removed to Stoulton by the family."

Hilda Gibbons of Chichester, Sussex, is doing a very enterprising job of spreading the word about handspinning. Together with her husband and two friends, she made a short film for the local amateur cine club to which they belong. When they had to decide on a subject for a film to enter for the annual competition, they thought it would make an interesting subject to demonstrate the processes of spinning. The film, entitled "Home Spun", lasts about 10 minutes, is in colour, with a commentary and demonstration by Mrs. Gibbons. In fact the film was so successful that it won the local competition, and we now hear that it has been "awarded the cup for the best film entered on behalf of a club in the South Eastern Region, and Certificates of Merit in two other big competitions". Well done, Mrs. Gibbons!

## BOOKS

Irene Waller is a well known weaver and textile designer, and her new book "The Craft of Weaving" (£1.45) would make a worthwhile addition to any weaver's bookshelf. Though concentrating mainly on the simpler techniques using frames and rigid heddle looms, the author balances well the need for practicality with creative imagination. It has many clear photographs, though regrettably none in colour, and plenty of ideas, both for the beginner and the experienced weaver interested in producing imaginative articles using simple equipment. It is also an excellent source book for teachers who want to know what can be done needing very little outlay.

At last! A reasonably priced book on inkle weaving. I suppose it was only a matter of time for someone to realise the need for such a book aimed at anyone who wants to build and use an inkle loom. "Inkle Loom Weaving" by Frances B. Smith (£1.95) starts with a chapter on making an inkle loom plus a few general hints, and then, through the weaving of specific projects, help the weaver to learn some of the many different techniques that can be done using the loom, with a useful chapter on the pick-up designs.

Finger weaving is one of my favourite forms of weaving, though I have to admit that some of the complicated patterns described in "Finger Weaving: Indian Braiding" by Alta R. Turner (£1.95) would need a tremendous amount of patience to do successfully. However for any weaver interested in the numerous possibilities available to the keen weaver who has no equipment, this is an ideal book. The author begins with the basic technique and then gradually the techniques get more difficult, so that some of the end results are really beautiful.

The well known black-and-white Dryad leaflets are now gradually going out of print. To replace these, Dryad are publishing more up-to-date versions in colour, one of the first of these being "Weaving with Card and Board Looms" by Linda Gordon (45p). This is a great improvement on the old leaflet on card weaving, and much more inspiring for the beginner at whom it is aimed. This is also an excellent book for teachers.

A classic book, and one with which many weavers are probably familiar, is "A Handweavers Pattern Book" by Marguerite Porter Davison (£9.75), now in its sixteenth reprinting. It is a unique book and one which could literally be described as a handweaver's 'bible'. It contains directions for the threading and treadling of hundreds of patterns for the four shaft loom, and includes a photograph of every pattern draft. If you are ever stuck for pattern ideas, this is certainly the book to have by your side.

(At the time of writing we have all the above mentioned books in stock, and will try to despatch books ordered by return of post. However please note that prices are subject to alteration, and that postage and packing charges are extra to all the above prices. For a copy of our latest book list, please send a stamped addressed envelope or two International Reply Coupons)

\* \* \* \* \*

## CLASSIFIED ADVERTISEMENTS

We should be pleased to receive your advertisements for Sales & Wants. The charge for this is 2p per word, payable in advance.

GUILD NEWS

The Norfolk and Suffolk Guild of Weavers, Spinners and Dyers have an interesting programme lined up for 1977. They meet monthly at Lowestoft, and among other things they have a one-day school on "Selvedges" in April, and talks entitled "Weaving Mad" (May), "Woad" (June) and "Angora Farm" (September). Their Annual Exhibition and Sale is to be held in Southwold from August 10-17. Further details from the Secretary: Mrs. J. Loftus, Greenacres, Church Road, Blundeston, Near Lowestoft, NR32 5AX. (Tel: Lowestoft 730552)

The newly formed Ceredigion Guild of Weavers, Spinners and Dyers are running several courses on "Weaving Lightweight Fabric" (April), "Spinning for knitting and crochet" (May), "Vegetable Dyeing" (May) and "Flax Spinning" (June). Further details from Pamela Heal, Perth Llwydion, Llanrhytud, Dyfed, Wales.

The Midland Handweavers Association meet about once every five weeks in Birmingham. They have organised a "Spinning Demonstration" by Dixon Wright (April), "Demonstration of Double Weaving" (May) and "Exhibition of Work" (September). Further details from the Hon. Secretary Mr. B.J. Wardell, 20, Jacey Road, Edgbaston, Birmingham, B17 0LL. (Tel: 021 454 5013)

\* \* \* \* \*

YARNS (mentioned in this issue of "Loomcraft")

2/16s Shetland wool in natural white only (CW 5/1) @ £2.24 per lb

2/7s wool in fawn only (CW 5/2) @ £2.24 per lb

Brown wool twist yarn (CW 5/3) @ £1.76 per lb

Green/pink looped wool yarn (CW 4/12) @ £2.40 per lb

15 cut Scottish homespun wool in 4 shades of green: bracken, border lovat, blue green and green lovat.

Was 96p per lb. - now reduced to £1.56 per cop (approx. 2-3 lbs)

N.B. Postage and packing charges are extra to all the above prices.

For samples, please send a stamped addressed envelope or two International Reply Coupons.

6/2s and 12/2s mercerised cotton available from Miss O.M. Scarfe, Guernsey Weavecraft, Juniper Cottage, Belmont Road, St. Peter Port, Guernsey, Channel Islands.

\* \* \* \* \*

STOP PRESS

Now in Stock .....

NATURAL JUTE - 3-ply & 5-ply - ideal for wallhangings, thick table mats or macrame - 99p per approx. 500 gram ball.

COLOURED RAFFIA - yellow, lime green, dark green, red, scarlet, mauve, purple, brown & black - 25p per approx. 1½ oz. hang.

WARPING MILLS - craftsman made, table model - £21.90

L<sup>A</sup>

LERVAD

now available from  
**CAMPDEN WEAVERS**

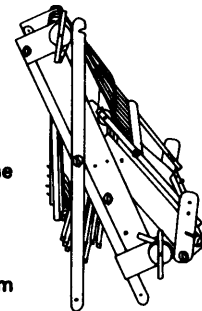

### LOOM NO. 9

This is the largest of the folding Lervad looms. It combines the technical features of the professional handloom with minimum space requirements, and therefore it is popular for home weaving and for weaving courses where room is at a premium.

Loom No. 9 has a weaving width of 80 cm 4 shafts, 6 treadles, and counter-march tie-up, thus it is possible to make most of the different patterns popular in home weaving. Contrary to many other small four-shaft looms, on which the tie-up is handoperated and cumbersome, No. 9 is provided with treadles. The counter-march tie-up system means that by operating the treadles one at a time all the shafts are moved simultaneously providing the required shed. This makes the weaving easier, quicker and less liable to errors. The counter-march tie-up system provides even and accurate sheds, which may be adjusted in size for different tensions of different warp materials. Loom No. 9 is made throughout of solid beech in natural lacquer finish, and the beams are provided with steel axle points. Heddles No. 243 and reeds No. 264 in a length of 80 cm should be used.

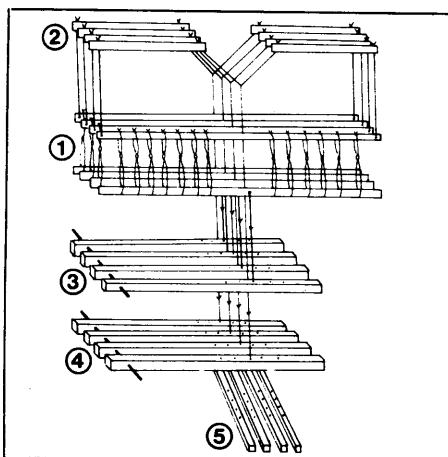

#### Tie-up System

The warp threads are threaded through the heddles on the shafts (1), which are lowered and raised to obtain the different sheds. The counter-march tie-up system works by means of jacks (2), short lamms (3), long lamms (4), and treadles (5), all these parts being connected with a system of cords. When one treadle is operated two opposing movements of the parts occur, raising and lowering the shafts. Thereby a double shed is provided which means less and even tension of all warp threads.

Cords are preferable to chains and wires in the tie-up, in that cords make less noise, give positive action, and are less tiring to operate. The workings of the counter-march tie-up system and the setting-up of the loom No. 9 is thoroughly explained in the free illustrated manual provided.

#### Specification and measurements:

4 shafts, 6 treadles, and 80 cm weaving width.

External measurements: Width 1005 mm (39 1/2"), depth 800 mm (31 1/2"), height 1120 mm (44").

Measurements folded-up: Width 1005 mm (39 1/2"), depth 590 mm, (23 1/4"), height 900 mm (35 1/2")

#### Accessories included:

Loom No. 9 is available with different sets of accessories to cater for the varying requirements of home weavers and weaving schools.

**Order No. 211:** 2 cross sticks, 2 beam sticks, 4 stick shuttles No. 260, 1 ball of tie-up cord No. 274, 1 illustrated manual.

**Order No. 211A:** In addition to items listed under No. 211: 500 heddles No. 243, 1 reed nr. 264, 40/10-80 cm, 1 threading hook No. 266, 1 reed hook No. 267.

**Order No. 211B:** In addition to items listed under No. 211 and No. 211A: 1 warping frame No. 233, 1 swift No. 276, 1 raddle No. 263A, 1 temple No. 265C. This last set includes all accessories used with the weaving example in the manual provided.



# LOOMCRAFT



CAMPDEN WEAVERS

Volume 9, No. 3

JULY 1977

\* \* \* \* \*

## CONTENTS

Editorial	page 2
The Story of the Lucet	3
When the Bug Bites	4
Stole	5
Books	6
Sample Piece	7
Selvages and Borders	8
Mailbag	9
New in Stock	10
Classified Advertisements	11
Guild News	11
Yarns	11
New Books	11

\* \* \* \* \*

Subscriptions - £1.10 for 4 issues  
(including postage and packing)

Issued quarterly - January, April, July and October

CAMPDEN WEAVERS  
16 LOWER HIGH STREET  
CHIPPING CAMPDEN  
GLOUCESTERSHIRE  
ENGLAND

Tel: Evesham 840864

Dear Weavers,

As the spinning demonstrations we held last year were such a success, we are arranging more for this summer. The dates for these will be Saturday 9th July and Saturday 20th August, and the times will be from 11.00am-1.00pm and 2.00pm-4.00pm on each of these days. They will take place in the garden at the back of our shop here, and we hope to have at least six spinners from the Stratford guild present on each day. However we are very much dependant on the weather, so if you are planning to come from a distance, it would be advisable to telephone first just to check on the weather. There will be a small admission charge towards expenses and Guild funds. We are certainly looking forward to these as they were such fun last year, and we hope that many of you will be able to come.

One Saturday last May we had a friendly invasion from a group of spinners and weavers from Cardiff. Renee Hill, who is one of our readers, teaches there and she organised a coach trip so that some of her students and their families could visit us in the morning. Even though it was like trying to move in a sardine tin inside the shop, I think they all enjoyed browsing around and it was wonderful for us to find such enthusiasm.

In the afternoon, the party went off to visit Snowhill Manor, which is about five miles south of here. There is a fascinating collection of spinning wheels and weaving equipment here, as well as many other interesting things. Charles Wade, who owned the house, was an inveterate collector of anything he could lay his hands on from spinning wheels and lace bobbins, to farm wagons and Japanese armour. The house is now owned by the National Trust and is set in a lovely garden, with terraces sloping right down the hill. It is certainly well worth a visit if you are in this area.

Also near here is the Cotswold Farm Park at Guiting Power. This is open nearly every day from May to October, and there are many rare breeds of animals to be seen. The sheep they have there include Jacob, Soay and St. Kilda.

Please do keep on telling us what you think about the magazine. We do value your comments, either good or bad, even though we do not have time to answer all your letters personally. It is only by finding out what you like or would like to see in the magazine that we know how to try and improve it for you.

Anyway, until we meet again, either in person or in the October issue of "Loomcraft", best wishes and happy weaving.

*Jennifer Green*

(Margaret Wright, who lives in Chipping Campden, is trying to revive the art of lucetting. The lucet produces a square cord, which makes an ideal finishing for woven articles, such as cushions)

The lucet has been variously described as a lyre shaped tool usually made of wood, bone or tortoiseshell. They have been found in old work-boxes of the 19th century and earlier. Some are mounted on a handle and are sometimes referred to as a "chain fork", chains being the term used in the Georgian era for the cords used for lacing and gathering both outer and under garments. For this purpose it was necessary to have a cord which was extremely strong and did not stretch. The square, tightly knotted lucetted cord was ideal.

When my mother, Elaine Tilney (nee Griffin), was 6 years old in 1890, an old lady then over 90, in Shiffnall, taught her to lucet, telling her that in her childhood (presumably in the early 1800s) it was considered old fashioned. My mother's family gardener, of a generation who took pride in doing the weekly cut of the tennis and croquet lawn with a scythe, copied an original lucet in holly wood, whittling it with a penknife - a skill he had acquired when he was a shepherd boy. I still have this lucet.

My mother taught me when I was about 6 or 7 at the end of the First World War. By coincidence we then had an old gardener who had been a shepherd boy, and he whittled a lucet for me, also out of holly.

In 1945 some fascinating articles by Sylvia Groves on needlework tools came out in the magazine "Country Life". At the end of one of these she described a lucet and said that beyond its name little information could be given about it for there appeared to be no recorded instance of its use. She had found a reference in a Trade Dictionary published in 1840 where it was described as a "Lady's lace-loom", which had set her enquiring of all the lace experts with no avail. The other meaning of lace had not occurred to her. I wrote and told her about it and in her book on "The History of Needlework Tools" published in 1966, she included the information which I had sent her.

In a Girl's magazine of the 1830s it states: "A lucet is a small instrument, something in the form of an Irish Harp, used for making little chains. As they can now be had at a lower price than the silk required for making one costs, the lucet is very little used".

They are occasionally to be found illustrated in 19th century books of needlework, but there are no directions, and it is generally stated that they were falling into disuse. In an 18th century book it was illustrated, but it was apparently taken for granted then that readers would know how to use them.

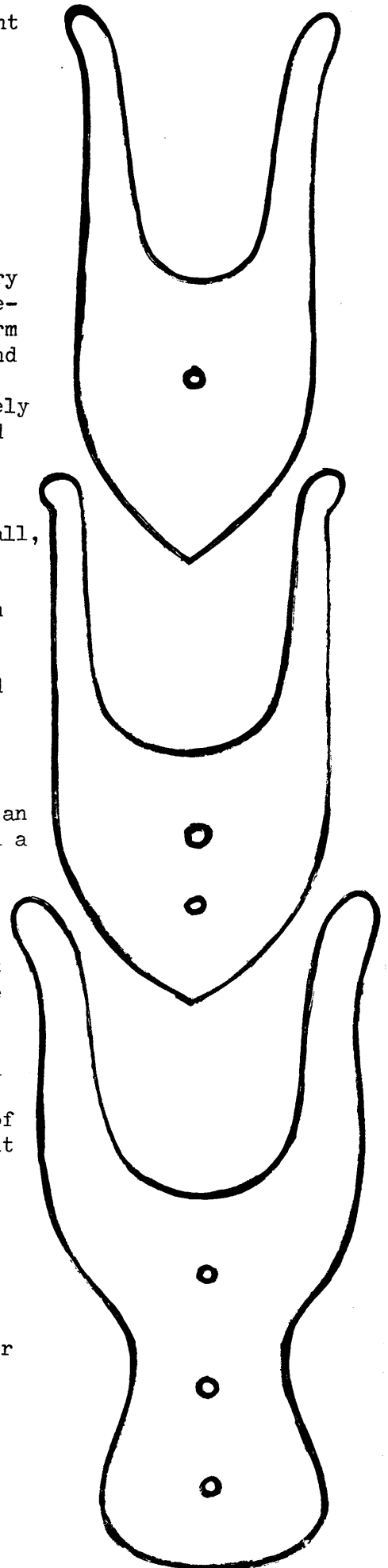

Recently I had a letter from Miss Groves in which she tells me that if she and I had not got together in 1945, lucetting might have disappeared altogether, for she has never found anyone else who had heard of it or known anything about it, although her interest in it has continued for over thirty years, and she has had enquiries from museums all over the world.

(Mrs. Wright would be pleased to hear from any readers who have more information about lucets or lucetting. Please write c/o Campden Weavers)

\* \* \* \* \*

WHEN THE BUG BITES (2)

by Ted Rogers

We have a dear friend who has a habit of saying "Oh, that's nice", or "I like that", to anything and everything she sees. In my case I should have been 'awarer'.

This friend asked if I could make some small samples, as she wanted to have some handwoven material for her grand-daughter. So, in time these were produced, to which the foregoing expressions were all made, including "I wouldn't mind a suit like that one" to an unusually bright check. On the strength of this, I wove one length for her grand-daughter and, as I thought, 5 yards for her. However, the latter was not taken up. So 5 yards of bright check lay about for some time until one day I jokingly said: "I wouldn't mind a jacket for the summer made out of this".

At this point I think it would be good to tell you more details. The yarn had been obtained as a special offer and was about 16 or 17 cut woollen spun. This was set at 20 ends per inch, 30" wide, with the selvedge doubled first and last 4, and sieyed 2 per dent in a 10 dent reed.

The warp -	20 brown	20 green
	4 white	4 white
	4 orange	4 orange
	4 white	4 white

As I am self-taught, the idea of making notes and keeping records has never occurred or appealed to me, so that the amount of yarn cannot be given with accuracy. But as the total weight of the warp was about  $4\frac{1}{2}$  lbs, if anyone wanted to work out individual colours with a yarn of approx. 100 yards per oz. it would not be too difficult for a mathematician.

The weft -	20 light blue
	4 yellow
	4 orange
	4 yellow, repeated throughout

From the foregoing I hope the reader can picture a reasonably striking cloth, which portrays the Biblical character whose name I do not possess.

Having persuaded my wife to make the jacket, the next obstacle was how to be 'a wearer'. The embarrassment was overcome one Sunday afternoon when visiting friends, and all was well. The white, or should I say coloured, elephant had been put to use. However, its and the creator's greatest triumph was to wear it at the next meeting of the Guild, which after a few raised eyebrows has now been accepted as a fact of life, and serves to show that in less than no time, if the bug bites, you too can be 'a wearer'.

A stole is a useful article for spring and summer evenings, and can be woven fairly quickly on a spaced warp. Using some of the lovely space dyed slub yarns now available, one can get interesting texture effects with just simple plain weave. This is an ideal article to make for those with 24 inch table looms or tabby looms.

For the warp I used 15 cut Scottish homespun wool, and as this is a singles yarn I used it double, that is 2 threads together (1 pale green and 1 dark green) through each heddle. The space dyed slub used in the weft is a mixture of emerald green, merging into olive green and then white, and looks very effective against the darker green background.

Length of warp: 3 yards  
 Width of warp: 24 inches  
 Finished size: 2 yards x 21 inches (+ 8 inch fringes each end)  
 Reed: 10 dents per inch  
 Ends per inch: 20  
 Total number of ends: 480  
 Threading: 1, 2, 3, 4 (1 light and 1 dark thread together through each heddle)

Sley the reed as follows:

4 threads through each of first 3 dents  
 miss 2 dents  
 \* 4 threads through each of next 2 dents  
 miss 2 dents  
 repeat from \* to last 12 threads  
 4 threads through each of last 3 dents

Materials:

Warp: 4 oz 15 cut Scottish homespun (CH4/3)  
 4 oz 15 cut Scottish homespun (CH4/4)  
 Weft: 4 oz 15 cut Scottish homespun (CH4/3)  
 8 oz space dyed green and white slub (CW4/16)

Pattern: Plain or tabby weave with yarns in the following order:

6	picks	fine wool
1	"	slub
5	"	fine wool
1	"	slub
4	"	fine wool
1	"	slub
3	"	fine wool
1	"	slub
2	"	fine wool
1	"	slub
3	"	fine wool
1	"	slub
4	"	fine wool
1	"	slub
5	"	fine wool
1	"	slub

repeat from the beginning for as long  
 as required

To finish, knot ends together in fours along each end, and cut fringe 8 inches or length required.

With the multitude of new books on weaving, spinning and dyeing being printed which include many new and interesting ideas, there are also many books which now seem to duplicate information, so that I find it very refreshing to find books which were obviously written with a clear audience and a clear aim in mind. Therefore for this issue I have chosen some of the books which have particularly impressed me.

"Cut My Cote" by Dorothy K. Burnham (£1.20) is a unique and very intriguing little book. The author has researched into the garments in the collection of the Royal Ontario Museum in Canada, and has discovered how many of the seemingly elaborate articles of clothing have been cut from a single rectangle of sometimes very narrow cloth. The pieces have been carefully worked out by their originators so that hardly any material was wasted - an important consideration in the days when material was a precious commodity and equally important for the handweaver today who wishes to make clothes from the precious fabric he has woven. While not giving the exact measurements of material required (which does rather depend on the individual garment) the width of the material and a diagram of the cutting pattern is given, so that these ethnic designs could easily be adapted to modern usage. What I found particularly ingenious about these designs was how even small triangles of material left when the main pattern piece was cut out, were utilized somewhere in the finished garment either to increase the fullness of the shirt or dress or to add to the armholes for easier movement. The designs are taken from garments which originated in all different parts of the world, and this book can be highly recommended for embroiderers and dressmakers, as well as weavers.

Until I read "Handweaving in Pioneer Canada" by Harold B. Burnham (60p) I had not realised that the traditional pattern known as Summer and Winter was so called because when used for coverlets the light side was left uppermost in the summer, while it was reversed and the dark side left on top in the winter. I found this book fascinating, as it briefly traces the different traditional influences which affected handweaving patterns in the early days of settlement in Canada. This booklet was originally published as an exhibition catalogue under the title "Keep Me Warm One Night".

We are often being asked for a reasonably priced book on pattern weaving, and so we were delighted when one of our customers brought "Patterns for Weaving" by Jocelyn Burt (£1.30) to our attention. This small hardback book is clearly and attractively set out, with photographs in black and white of each pattern and eight colour plates. It gives specific details on how to weave many attractive patterns from 'One's and Two's' to 'Jolly Jumbuck', and includes suggestions of yarns to use and the sett these yarns would require. Altogether this is a book that we would recommend to any weaver, and it is certainly very good value for money.

There is also another book in the same series as the one above which is of interest to weavers. "Tapestry Weaving" by Jess Brooke (£1.30) is an excellent guide for the beginner who wants to try weaving tapestry. The techniques are clearly explained with the aid of numerous diagrams. The book also covers colour, design, equipment and yarns, with a list of suggested projects to weave. There is also a useful bibliography which leads the reader on to where to find more detailed information.

(At the time of writing we have all the above mentioned books in stock, and will try to despatch books ordered by return of post. However please note that postage and packing charges are extra to the above prices (25p for one book in U.K. only). There is no V.A.T. on books).

SAMPLE PIECE

by Evelyn Green

There are so many lovely textured yarns available these days that it is up to us weavers to make the best possible use of them. A complicated pattern weave is often quite lost when using fancy yarns, so a simple weave is all that is necessary to show off the beauty of the yarns.

One of the great weavers of the early twentieth century, Ethel Mairet, whom some of our readers may remember living and working in Ditchling, Sussex, wove many of her fabrics in plain or tabby weave. She got the most wonderful effects simply by using threads of different thicknesses, spaced warps, textured yarns and beautiful colours.



In this sample piece I have used an unusual wool/flax yarn in two different shades, and a finer tan wool yarn. The weave is called Hopsack with Tabby Squares, and you will see that the hopsack is woven with the wool/flax, and this is outlined by the tabby squares in the tan wool.

This is a fairly heavyweight fabric and should be hardwearing with the flax and wool mixture, suitable for upholstery material, bedspreads, or possibly curtain material which would not require lining.

Length of warp: 4 yards

Width of warp: 32 inches

Finished size - before milling: 3 1/2 yards x 30 inches  
after milling: 3 1/4 yards x 28 inches

Reed: 10 dents per inch

Ends per inch: 15 (sleyed 2, 1, 2, 1, in the reed, making sure that the 2 fine threads are threaded together through a dent)

Total number of ends: 484

Materials: 1 1/2 lbs orange/salmon flax/wool (CH 9/2)  
1 1/2 lbs pink/red flax/wool (CH 13/2)  
1/2 lb tan wool (CW 4/2)

Threading:

4	4	4	4	4
	3		3	3
		2 2		2
		1 1		1
selvedge	balance	pattern repeat	selvedge	shafts
		6 threads		

Note All threads numbered 1 are orange/salmon flax/wool  
" " " 2 " pink/red flax/wool  
" " " 3 and 4 are tan wool

Analysis of threads:	Selvedge	1
	Pattern 6 threads, 80 times	480
	Balance	2
	Selvedge	1
		<u>484</u>

Pattern: the shaft lifts are as follows:

1 & 3	)	
2 & 4	)	tan wool
1 & 3	)	
1 & 3	)	orange/salmon flax/wool
2 & 4	)	
2 & 4	)	pink/red flax/wool

repeat for length required

As the two picks of flax/wool thread are laid in the same shed, make sure that the shuttle goes round the selvedge thread each time in order to hold them in position.

\* \* \* \* \*

### SELVEDGES AND BORDERS

by Vera Miles

There have been many troubles with selvedges, especially when weaving twill - lifting 1 & 2, 2 & 3, 3 & 4, 4 & 1. It is all so silly simple.

Most selvedges are threaded 1234 or 4321. Just double thread the first and last 2 threads, thereby starting with a number 2 heald on right and finishing with number 3 heald on left. If you reverse the direction of twill, simply use another shuttle and so throw from correct side. It works perfectly. I have been doing this for 25 years.

Do not double thread through reed for selvedge - that one double thread only once both ends is all that is needed to take the strain of last and first threads of work, and gives a firm edge.

When weaving a mock-leno weave or a huck-a-back weave, and we want a plain tabby border both sides, and we have an uneven tie-up of pedals - three up, one down, etc. - or uneven lift on a table loom, look at your threading of pattern carefully. It will be seen that every other thread is either a 1 or 4, or some patterns it is 2 or 3, so thread those borders (as many threads as needed) 1,4,1,4 etc. or 2,3,2,3 and hey presto, a perfect tabby border.

\* \* \* \* \*

### TIP FOR WASHING HANDSPUN WOOL

If you want to keep the natural grease in your yarn after spinning, but want to get rid of the dirt, try washing the wool in cold water. This must be done by hand very carefully. A small amount of wool detergent can be used if the yarn is really dirty. When rinsing this, still use water at about the same temperature. Gently dry by squeezing the wool, not wringing it, and let it dry finally away from direct heat or sunlight.

To remove the lanolin altogether, wash the wool in warm water using a good quality soap flakes, and then rinse in warm water. Dry as above. If the yarn is a single thread, it is advisable to hang a weight on it when drying, as this will stop the yarn 'kinkling' up.



## MAILBAG

Two of our New Zealand readers, Pat Deacon and Kath Maloney, have been kind enough to send us a subscription to "The Web", which is the quarterly journal of the New Zealand Spinning, Weaving and Woolcrafts Society. It is certainly very interesting to see other magazines and read about what is going on in other countries. The articles in the November issue, for example, ranged from fleece rug weaving and handspun embroidery wools, to news and views about exhibitions and courses, and we are most grateful to Mrs. Deacon and Mrs. Maloney for sending it to us.

Margaret Wanstall wrote and told us about the Kiwicraft competition that took place during the three-day New Zealand Spinning, Weaving and Woolcraft Festival, which was held in Nelson, last March. For this competition "a team produce a beret in a certain time" and there was also "the silver spinning wheel competition where a team of six are given fleece to spin, knit and sew up a child's jersey in three hours and judged on the best finished jersey". There were also many classes which went on at the same time and "dozens of trade stalls. We had 800 members from all over New Zealand and believe me there was so much to do and see, and so many old friends to talk to, there wasn't enough time. Next year we are holding the festival in Auckland; it would be great to have some visitors from Great Britain".

After reading Ted Rogers' article in the April issue of "Loomcraft", Mr. E.W. Newnham of Humberside wrote to tell us about the loom he has made. "Wandering around a furniture auction room in Bridlington, I saw some old spring mattresses tucked away in a corner, and after enquiries had five of them delivered to me at a total cost of £1. After dismantling them and disposing of all the metal, I had plenty of first class timber to build my 36" foot loom with overslung batten. The warp and cloth beams are made from  $\frac{3}{4}$ " thick cardboard tubes, five inches diameter, supported on  $\frac{1}{2}$ " steel bars. The cloth beam is turned by means of a pedal operated pawl and ratchet, and the warp release is by means of weights on a rope that is wrapped around the warp beam - a very old but entirely satisfactory method of control; the weights are adjustable to give varied warp tension. The loom is completely dismountable and has travelled quite a lot".

Jean Loftus, who is secretary of the Norfolk and Suffolk Guild of Weavers, Spinners and Dyers, wrote to tell us about a course on natural dyeing held recently at Belstead House, near Ipswich, Suffolk. "The course was fortunate to have Roy Russell and Wilma Hollist as tutors, and the seventeen students included eleven members of the Norfolk and Suffolk Guild. Whilst outdoors it was dull, dismal March weather, the colours produced during the dyeing sessions were anything but dull. The indigo vat process gave a marvellous range from palest sky-blue through to mid and deep blues. Cochineal was an extremely rewarding dyestuff, from half-a-dozen small dead insects granulated to a spoonful. The range of pinks, reds, scarlets and purples seemed endless. The effects of the various mordants were explained and tried out, and fantastic colours resulted when over-dyeing was done. The tutors were always willing to advise and explain, and during the first evening gave a talk on dyeing techniques illustrated with many samples of dyed cotton, wool, silk, jute and mohair. The following night some enthusiastic folk were still experimenting at midnight, and by the end of the course a very wide range of colours were evidence of a very busy three days."

The small town of Kendal, Westmorland, is "known for its wool and weaving activities - Shakespeares men in Kendal Green". Mrs. E. Wegener, who originally comes from there also tells us that the town's motto is "Wool is my Bread".

Mr. and Mrs. F.W. Sturgess of Northumberland "both enjoy being involved with people and this is the real reason why we took up the teaching part of weaving". Apart from "teaching weaving part-time for Northumberland Education Committee

for several years" they are now organising courses in their own home, with the participants staying in local guest houses.

\* \* \* \* \*

#### NEW IN STOCK

- THRUMS - 1 lb bags of 2-ply carpet wool of varied lengths, mixed colours  
@ 75p per bag
- THRUMS - 4 oz bags of 2-ply carpet wool of varied lengths, each bag containing  
between 2 and 4 colours in one colour range. (When ordering  
please state colours preferred)  
@ 30p per bag
- POLISHED COTTON TWINE - 3-ply, very strong, ideal for macrame, fawn only  
@ 70p per 125g ball (approx 4 oz)
- DISHCLOTH COTTON - contains 15% rayon, available in white, yellow, pastel blue,  
purple and red  
@ 68p per 4 oz hank
- 2/12s LINEN - natural fawn only, on approx 1½ lb cops  
@ £2.50 per cop
- 2 fold LINEN - white only, on approx 1½ lb cops  
@ £2.50 per cop
- SPINNING WHEEL PLANS - for making Norwegian, Welsh and Upright spinning  
wheels. Each folder contains poster, scaled working  
drawings, cutting lists of pieces of wood required and  
notes on construction for one type of spinning wheel.  
When ordering please state which type of wheel required.  
@ £3.00 per plan
- SPINNING WHEELS POSTER - as included with the plans above, black and white,  
depicting three different types of wheels, ideal for display  
with lectures or exhibitions  
@ £1.00 each poster
- JUTE - dark brown 5-ply jute, on approx 1¾ lb cops (210 metres length)  
@ £4.30 per cop
- NOTELETS - We have now added two more designs to the notelets we can supply,  
both by the same local artist, David Birch. One is of an  
upright spinning wheel and the other is of two Jacob sheep.  
The family of sheep. Herdwick, Devon Longwool and front of  
Campden Weavers shop are still also available.  
All designs are priced at 25p per packet of 5 notelets  
with envelopes.
- LUCETS - hand made in wood, with or without handle.  
@ £1.60 per pack, including full instructions and a sample  
piece of lucetted cord.

(Please note that postage and packing charges are extra to all the above prices.  
Our latest price list is available free of charge to anyone who sends us a  
9" x 4" stamped addressed envelope, or 2 International Reply Coupons)

CLASSIFIED ADVERTISEMENTS

We should be pleased to receive your advertisements for Sales and Wants.  
The charge for this is 2p per word, payable in advance.

GUERNSEY. Combine a holiday with weaving lessons. Self-accommodation flat available in lovely surroundings of old Manor House (1611) - or other accommodation found. Write for brochure or telephone Mrs. Margaret Hayes, The Weaving Studio, Le Manoir de la Foret, Guernsey, Channel Islands. Telephone 64114.

FOOT POWER LOOM WANTED. Weaving width 60-72 inches, 8 or more shafts. Clare Coutts, 7 Royal York Crescent, Clifton, Bristol 8.  
Bristol 37358.

WANTED. Information on preparing nettles for spinning. L. Griffiths, Prospect, Chorlton Lane, Chorlton, Chester.

\* \* \* \* \*

GUILD NEWS

2 members of the Somerset Guild of Weavers, Spinners and Dyers will be demonstrating at a Craft Fair to be held at Carnaby's, Tabernacle Lane, Yeovil, Somerset, on 19th and 20th September.

The Annual Exhibition and Sale of the Norfolk and Suffolk Guild of Weavers, Spinners and Dyers takes place at the United Reform Church Hall, Southwold, Suffolk, from 10th to 17th August, and is open from 10.00am to 5.00pm.

The Birmingham and District Guild of Weavers, Spinners and Dyers have a practical session on Double Weaving lined up for September 24th and a one-day school on Inkle Weaving on October 15th. Further details from the Secretary, Mrs. L.F. Stringfellow, 680 Evesham Road, Redditch, Worcs.  
Telephone: Astwood Bank 2535.

YARNS (mentioned in this issue of "Loomcraft")

15 cut Scottish Homespun Wool in three shades of green: bracken, blue green and green lovat.  
Available only on 2-3 lb cops  
@ £1.50 per cop

Green/white slub yarn (CW 4/16)  
Also available in red/white (CW 4/17)  
@ £2.40 per lb

Brown wool (CW 4/2)  
@ £1.76 per lb

Wool/flax, available in red/pink and salmon/fawn only  
@ £1.60 per lb

\* \* \* \* \*

NEW BOOKS IN STOCK

"British Sheep Breeds" £2.10

"Three Bags Full" by John Claxton and Sally Douglas. Children's book on how wool is spun and woven.  
70p

"Craft Workshops in the Countryside: England and Wales" published by CoSIRA, 1977 edition, 75p

"From Loom to Tomb" Catalogue of exhibition of Pre-Columbian fabrics held at the Royal Ontario Museum  
25p

"Handweaving and Cloth Design" by Marianne Straub £5.75

"Weaving As A Hobby" by Marguerite Ickis £2.95

"Frame Loom Weaving" by Jane Redman £9.60

"Weavers Study Course: Ideas and Techniques" by Else Regensteiner £12.90

"Caring for Textiles" by Karen Finch and Greta Putnam £3.95



# LERVAD

## now available from CAMPDEN WEAVERS



### LOOM NO. 7

is the ideal choice for most homeweavers. Small and compact, there will be room for it almost anywhere, yet it has a weaving width of 100 cm and 4 or 6 shafts bringing a wide variety of weavings and patterns within the scope of the home weaver. The elegant design will often make it a treasured piece of furniture, too.

Loom No. 7 is provided with an overslung beater, which is easier to work with than an underslung beater. Breast bar in front and back ensure that the warp keep the same level in the loom whatever the length of warp. This helps to keep an even shed throughout the weaving process. When the treadles are hinged at the back of the loom, they are more convenient to operate. Despite its light and pleasant design loom No. 7 is firm and rigid as it is accurately made of solid beech in lacquer finish. Other timbers may be used for sticks etc. Beams are provided with axle points and ratchet wheels of electro-galvanized steel. Heddles No. 244 and reeds No. 264 in a length of 100 cm should be used.

The No. 7 loom illustrated here is set up with a dress fabric in 2/2 twill or tweed. The width is 90 cm using 5/1 wool for both warp and weft.

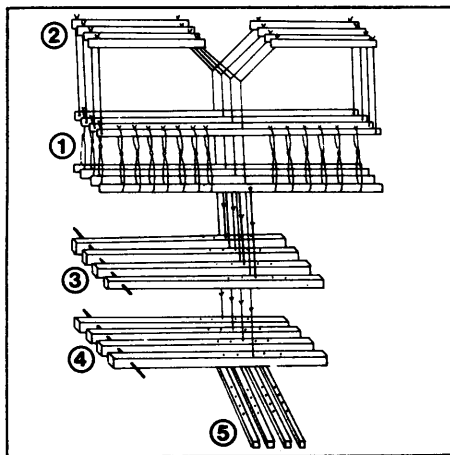

### Tie-up system

Compared to counter-balance and similar tie-ups, the counter-march tie-up of No. 7 has the advantage of all shafts being moved up and down in one movement by the operation of only one treadle at a time. The counter-march system comprises the following parts: Jacks (2), shafts (1), short lamms (3), long lamms (4), and treadles (5) all being inter-connected by cords. When one treadle is operated two opposing movements of the parts occur, raising and lowering the shafts and thereby providing a double shed, putting less

strain on the warp threads. Cords are preferable to chains and wires, in that cords make less noise, give positive action, and are less tiring to operate. The counter-march system and the setting-up of loom No. 7 is fully explained in the free illustrated manual provided.

### Specifications and measurements:

Order No.	Number of shafts	Weaving width	External width	Depth	Height
209-4A	4	100 cm	1190 mm	800 mm	1390 mm
209-6A	6	(39 1/2")	(47")	(31 1/2")	(55")

### Accessories included:

2 cross sticks, 2 beam sticks, 12 warp sticks, 4 sticks shuttles No. 260, 1 ball of tie-up cord No. 275, 1 manual, 1 stool No. 227, 500 heddles No. 244, 1 reed No. 264, dentage 40/10-100 cm, 1 threading hook No. 266, 1 reed hook No. 267.

### Add "B" to order No.:

In addition to items listed above: 1 warping mill No. 229, 1 swift No. 276, 4 boat shuttles No. 249, 25 bobbins No. 256, 1 raddle No. 263B, 1 temple No. 265D, 1 bobbin winder No. 269. This list set includes all accessories used with the weaving example in the manual.

ANDERS LERVAD & SØN A/S · ASKOV · DK 6600 VEJEN · DENMARK