

sericin remaining on the fibre and its condition, *i. e.*, its strengthening; by the action of the formaldehyde. It is also claimed that silk thus treated acquires increased lustre, but nothing is said as to the effects of this treatment on the after-dyeing of silk put through the process. This point should be considered, and it should be remembered that formaldehyde is a very powerful reducing agent and will affect certain dyes unless entirely removed from the silk, to which it adheres tenaciously.

HANDLING WEIGHTED SILK. If the silk has been weighted in the raw state, *i. e.*, made heavier by the addition of mineral matter, as is sometimes done with fraudulent intent, the metallic oxides thus deposited on its fibres must be removed before the silk is put into soap solutions, otherwise they will decompose the soap, weakening the bath, and form insoluble metallic soaps that are very difficult to get out of the silk if once deposited on its fibres and which tarnish and discolor them. The bodies usually found in such weighted silk, are oxides of iron and tin, which are soluble in dilute acids, hence they are removed by soaking the silk in a mixture of hydrochloric acid and water, until all of the mineral matter is dissolved, after which the silk is drained and rinsed until free from acid. It may be found an advantage to add a little carbonate of soda to the second rinse-water to make sure that the acid will all be washed out of the silk before it is put into the soap solution; if any traces of acid remain, they will *curdle* the bath, decomposing the soap and depositing fatty acids on the silk fibres. This process will also facilitate the soaping, by removing much of the dirt and gum. Litmus paper should be used for testing the rinse waters until they show no trace of acid.

Boiled-off Silk in its finished state has been subjected to several processes, each of which consists of a number of operations, the object being, as before stated, the complete removal of all gum and coloring matter from the silk. The complete process, as usually carried out, is divided into three separate operations, known as (1) Stripping or Ungumming; (2) Boiling-off; (3) Bleaching.

(1) **STRIPPING.** In this operation the silk is deprived of most of its gum and coloring matter by working it in a hot solution of soap, about 3 lbs. of soap to 10 lbs. of silk, dissolved in about 3 to 4 gallons of water, for an hour or so, beginning at about 190° to 195° F. and raising the temperature of the bath to about 203° to 205° F. toward the end of the process. This operation is performed in large vats, preferably of wood, holding 50 to 80 pounds of raw silk, using sufficient water to cover the silk well and to allow it to be worked freely. The silk is then squeezed, drained and well rinsed in a bath containing about $\frac{1}{4}$ lb. of soap and 2 oz. of carbonate of soda to the gallon of water, after which it is again squeezed and drained and rinsed in clear water. If the silk is very dirty, or if it is required to be very light colored for dyeing light shades, it may be necessary, or desirable, to repeat the working in soap solution, using two, or even three, more soap baths. The first soap bath used then should contain $2\frac{1}{2}$ lbs. of soap for every 10 lbs. of silk, the sec-

ond bath will contain $1\frac{1}{2}$ lbs. of soap to each 10 lbs. of silk; and the third bath only 1 lb. of soap to each 10 lbs. of silk, using water enough to work the silk thoroughly in the solutions; about 4 to 5 gallons to 10 lbs. of silk. The last soap bath may be used again as the second bath for another batch of silk, by adding to it 1 lb. of soap for each 10 lbs. of silk and sufficient water to make up for any previous loss.

Experience is necessary for carrying out these different operations properly so that none of the material is spoiled. The principle to bear in mind is that the process should be conducted so as to remove the gum and coloring matter from the silk without affecting the fibre, the treatment in the soap baths should continue only long enough to accomplish this, as a prolonged soaking will soften the fibre and cause it to take up coloring matter from the bath which is very hard to remove.

When first placed in the hot soap solution, the silk swells up and becomes sticky, but after a few minutes the gum begins to dissolve and the silk soon becomes glossy and clean looking. Here, the practical man can often save time and material by using his judgment in treating different silks, leaving some in the bath longer than others and giving to different lots the number of baths best suited to their character and quality.

(2) **BOILING-OFF.** After the stripping has been complete, the next process is "boiling-off," in which the stripped silk is put in hemp or flax bags, called *pockets*, and these are put into boiling vats or kettles containing a 10% solution of soap and boiled for about half an hour, after which the silk is taken out and well washed with clear water. It is not absolutely necessary to put the silk in bags, in fact the silk is often simply hung from wooden rods and immersed in the boiling soap solution. Care must be taken that the silk does not become tangled up badly during the boiling, and no iron must come in contact with it, which would cause rust stains.

The soap solution used for boiling-off can be again used for stripping another lot of silk when strengthened by the addition of sufficient soap. Indeed, by judiciously working up soap solutions used in the final processes for one lot of silk for use in the first treatment of another lot, a great saving in expense can be made. This subject will be more fully treated in a later chapter, which will also take up the questions of the character and quality of the soap and the water used for scouring silk, two very important items to the silk scourer.

(3) **BLEACHING.** The final process through which the silk is put is bleaching. This may be done either by exposing the silk to the fumes of burning sulphur in a closed chamber, or immersing it in a solution of bisulphite of soda with an acid, to free the sulphurous acid gas, or by treating it in a bath with peroxide of hydrogen or peroxide of sodium. The sulphur process is very unsatisfactory, both because of the trouble and annoyance of the operation and the fact that it is not a permanent bleach. Either peroxide of hydrogen itself or peroxide of sodium are far superior to the old processes, and they are becoming used for

silk more and more extensively. Under a special chapter heading later on, the subject of silk bleaching will be treated in detail, more particular bleaching with peroxide of sodium.

(To be continued.)

A COLOR TABLE FOR MANUFACTURING PURPOSES.

The purpose of the same is to conveniently ascertain which colors to combine in the construction of textile fabrics to obtain a harmonious effect.

This table consists of two concentric disks divided into sections of different colors and capable of being moved to any desired position in relation to each other,

is the same, viz: first, yellow; second, orange; third, cinnabar red; fourth, crimson; fifth, purple; sixth, purple violet; seventh and eighth, ultramarine blue; ninth, Turkish-blue; tenth, bluish green; eleventh, cinnabar green, and twelfth, yellowish green. The colors of the larger of the two disks (Fig. 1) gradually become lighter in shade toward the circumference and those of the smaller disk (Fig. 2) gradually become of a deeper shade as they approach the centre. A gray annular border surrounds the twelve colors of the larger disk, the outermost portion of which is occupied by the three tertiary colors, viz: yellowish brown, bluish brown, and reddish brown.

These diversely colored sections of the disks may

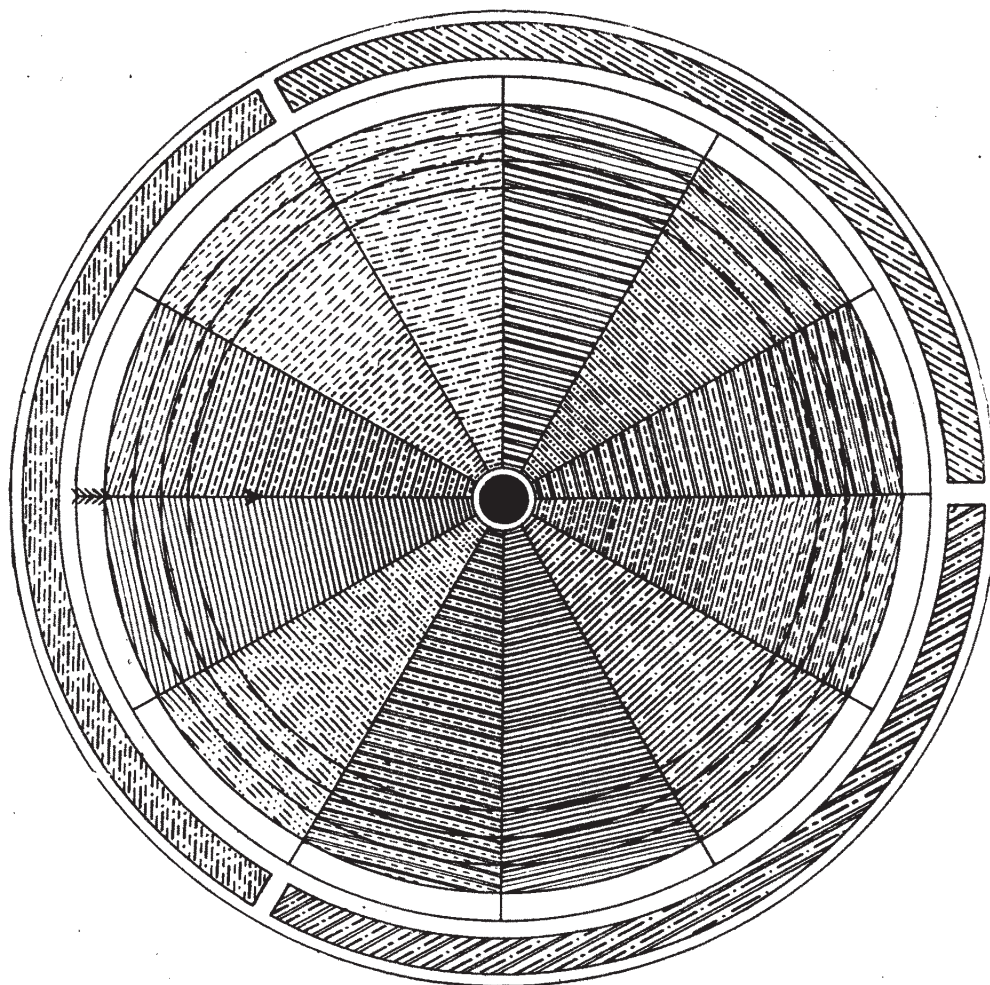

FIG. 1

the object being to enable harmonious sets or combinations of colors to be formed, and colors that match or agree with each other to be found or determined. For this purpose the two disks, such as shown by way of example in the two accompanying illustrations, are divided into twelve equal parts or sections, each of a different color; each disk having sections colored as follows: *three primary colors*: yellow, red, blue; *three secondary colors*: orange, violet, green; and six colors made up of *combined primary and secondary colors*: orange-yellow, orange-red, violet-red, violet-blue, bluish-green, and yellowish-green.

The order of succession of the colors on both disks

be arranged in any imaginable relation to, or juxtaposition with each other, so that, whenever any two colors are placed side by side, the degree of contrast or harmony existing between them immediately becomes manifest, and their fitness, or otherwise, to appear in juxtaposition or conjunction with each other may be tested, while groups of two, three or four well-matched colors, such as are apt to be required in practice, may be readily formed. Thus contrasts and effects most pleasing to the eye may be produced by the diagrammatic arrangement of two, three, or more colors, either in succession, or in any desired relation to each other.

A FEW EXAMPLES will best explain the operation of this color-table. Assuming, that the two disks are so adjusted that each color of the one coincides with or meets the identical color of the other, and that the arrows marked upon them, respectively, point toward each other, we will see that the effect of the juxtaposition of, say, orange and yellow, is not a pleasing one, owing chiefly to the affinity these two colors have for each other. Again, the juxtaposition of two colors of the same shade or tone is generally inharmonious and not to be recommended as they will mostly interfere with each other. Nevertheless, a pleasing effect may be produced by placing two kindred colors side by side, one of which is a shade deeper than the other. For this reason each of the colors on the color disk presents an entire scale of shades or tones to facilitate the choice of such two similar colors, as will match when they meet, owing to their different shades.

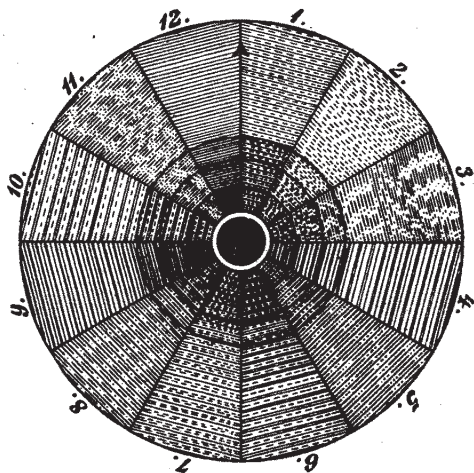

FIG. 2

To find two colors calculated to jointly exercise a pleasing effect on the observer's eye, it is only necessary (for example) so to adjust the two disks that section No. 1 (yellow) of the inner disk meets section No. 7 (bluish-violet) of the outer disk, when all the other pairs of colors brought into juxtaposition on the table will be found to match and mutually to enhance their value; thus, for example, orange will come next to ultramarine blue, crimson next to bluish green, etc. Combinations of such colors as these will, at all times, have an excellent effect, no matter what may be their shade or degree of opaqueness.

More harmonious effects may be produced by coupling any of the three tertiary colors with the eight colors facing them on the larger disk, and in each case the six central colors will form the most pleasing contrasts. As to the four colors of the outer disk which are encompassed by the tertiary colors, they are too closely akin to these tertiary colors to produce an agreeable effect.

If it be desired to form a harmonious group of three colors, *i. e.*, to couple two suitable colors with a third one taken as a ground color, whose effect is to be enhanced by such addition, and supposing the ground color to be No. 1 of the inner disk, the colors to be coupled with it will be 5 and 9 of the outer disk. If No. 1 (yellow) of the inner disk joins No. 5 (purple)

on the outer disk, the following harmonious triple groups will form (for example) yellow, purple and turquoise blue; orange, purple-violet and bluish green; crimson, ultramarine blue and yellowish green, etc. These examples no doubt are sufficient to illustrate to our readers the manner in which this color table may be utilized for textile manufacturing purposes.

I. A. Hall's New Shuttle,

or as might be more properly said, NOVEL FORM OF CONSTRUCTION OF A SPINDLE FOR LOOM SHUTTLES, is shown in the accompanying three illustrations, of which Fig. 1 is a fragmentary view of a shuttle, showing one form of the new spindle and its toothed strip for holding the bobbin or quill securely on the spindle, during the running of the loom. Fig. 2 is a plan view of the spindle and strip of Fig. 1 removed from the shuttle; and Fig. 3 illustrates another form of construction of spindle and strip.

THE OBJECT in either form of construction consists in providing means for positively preventing the cop or quill in a shuttle from slipping lengthwise on its spindle when the latter is in the depressed position, which means, however, are inactive when the spindle is in the raised position.

DESCRIPTION OF THE CONSTRUCTION OF THE NEW DEVICE. Examining for this purpose diagrams Figs. 1 and 2 more in detail, we find, as is customary in all shuttles, mounted in its body *a*, on a pin *b*, the spindle *c*. The latter is formed with a longitudinal slit *d*, and projection *e*. Spring *f* is held, as usual, under tension by pins *g*, so as to hold the spindle securely in either position, *i. e.*, whether the latter is elevated (for removing or applying the bobbin or quill) or depressed (as is the case during the running of the loom). *h* is a strip having its top edge toothed at *i*. This strip is pivoted on a pin *h'* near its outer end in the spindle in the slit *d*, its lower edge being formed in a lug *j*. When the strip is elevated, *i. e.*, in the full line position shown in Fig. 1, its teeth project from the spindle and thus engage the bore of a cop or quill whereby to hold the latter against slipping on the spindle, whereas when the strip is depressed, its teeth or serrations disengage or clear the bore of the cop or quill, which may thereupon be removed without hindrance. The strip is depressed when the spindle is elevated, and, vice versa, it is elevated when the spindle is depressed, accomplished by the two pins *k* and *l* respectively mounted in the shuttle body *a* above and below the spindle, so that when the spindle is raised, it will move the strip against the stop *k*, depressing the strip, and when the spindle is depressed, the strip will be thereby engaged with the stop *l* and caused to be elevated.

In the construction shown in Fig. 3, the slit *m* in the spindle is in this instance shaped to form a seat *n* for a small spiral spring *o*. The toothed strip *p* is pivoted in said slit near its outer end and formed at its inner or free end with an extension *q* which rests on said spring and has an integral downwardly extending pintle fitting into the spring to keep the parts in proper operative position. Above the said inner end of the strip is a stop pin *s* mounted in the shuttle in such

position as to be only engaged by the extension q when the same is raised; one function of this stop being to prevent the strip from becoming disengaged, as regards its pintle, from the spring o . In this instance,

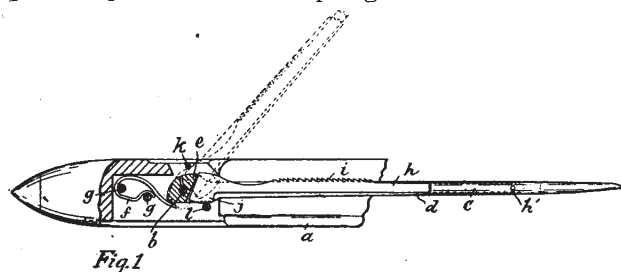

Fig. 1

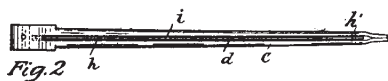

Fig. 2

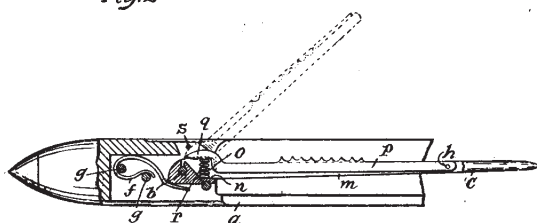

Fig. 3.

when the spindle is elevated, the extension q brings up against the stop s , which causes it to be depressed in the spindle so that its teeth will be disengaged from the cop or quill, whereas when the spindle is depressed the spring at once raises the strip, causing the teeth to engage the cop or quill and so hold the same against slipping thereon during the running of the loom.

Ribbon Weaving in France.

Consul W. H. Hunt, in response to an American request regarding this industry, has in the January issue of the Consular and Trade Reports, furnished a most interesting article on this subject, *i. e.*, regarding St. Etienne, the chief city in France with reference to that industry, and from which report we quote: "The production of ribbons produced in St. Etienne amounted in 1906 to \$19,000,000 being an increase of \$3,000,000 over that of the previous year; ribbons produced being exported all over the world. The prominence given to St. Etienne in the production of ribbons is due to two factors, one of which is its pure water, which is ideal for dyeing purposes, the other reason being that of the well-known special aptitudes of the weavers who by nature are artists in their trade. Handed down from father to son, all the secrets of the industry, the delicate manipulation of the threads on the looms and the varied combinations of the design to obtain the most artistic effects, are, and will remain, the distinctive and attractive features of the St. Etienne ribbon industry."

Mr. Hunt at the same time also gives a good description of the general living of these French weavers, showing that "as a class they are sober and intelligent men, living frugal lives; totally absorbed in their trade. A large number are not only proprietors of their looms, but also of their houses, and it may be said that many quarters of St. Etienne were built by

them. A model weaver's home consists of three rooms (all the working people live in tenement houses), one long and large enough to contain three looms, two family rooms, of which one is the kitchen, eating, and bedroom combined; the other is the bedroom of the parents and contains the best household furniture. The homes are clean and neat, presenting a contrast with those of workmen of other trades.

Their diet consists of soup, morning and evening, made of a curious mixture of bread, potatoes, and cabbage, to which a slice of bacon is added to give it a flavor. The dinner is composed of meat, vegetables, cheese, coffee, and a quart of red wine, while the supper is made up of soup, the remainder of the dinner, and the usual bottle of wine. As will be seen, the French weaver lives fairly well, but without any extravagance. He seeks no pleasure beyond a walk in the country on Sunday or an occasional visit to the theater.

The earnings of a weaver are difficult to calculate, but \$1.35 per day may be considered as an average for the year round. At some seasons he will earn as much as \$2 to \$3 a day, while at others he will not make more than 60 cents, or his looms may lie idle for a few days. In the factories the work is more regular, but frequently short time is imposed, the ribbon industry, depending entirely on the caprice of fashion, is subject to constant fluctuation."

Loom Reed.

Lately a reed has been patented which on account of its peculiar construction is herewith referred to. This reed has some of its dents provided with an outwardly extending foot, adapted to project across the upper face of the lay, and form a grating of parallel bars between which the warp threads lie and over which the shuttle passes without coming in contact with the threads, hence, as the inventor Mr. A. Marcante claims, avoiding any tendency to roughen up the fibres and break the delicate threads.

In the same way, to prevent the shuttle from flying out, and in this way engage and possibly tear some of the threads of the upper shed, the inventor also provides similar extensions on some of the dents to project outward from the upper edge of the reed, thus forming two sets of extensions to the reed, one above and one below the path of the shuttle; and when the shed is open the warp threads are then in both planes of the shed, drawn into the spaces between these extensions of the reed, so that it is impossible for them to be touched by the shuttle in passing on its way through the shed.

We have not illustrated the new reed, since the same is a most simple affair, and from description given will be readily understood by the reader; again there seem to us greater drawbacks to the use of such a reed than its advantages claimed by the inventor; a good loomfixer, it seems to us, being a superior adjunct to prevent chafing of the warp threads and stop the shuttle from flying out—in fact the construction of the new reed might be just the cause for either or both.

KNITTING:—PROCESSES AND MACHINERY.

A STUDY OF KNITTING

With a Description of Knitting Processes and of the Construction and Operation of the Prominent Knitting Machines.

(Continued from page 81)

Classification of Knit Goods. In order to cover the manufacture of knit goods in a systematic and thorough manner, it will be best to make some classification of these into general divisions before describing the various knitting machines and their operation, and then to follow the same system of classification in describing knitting machines and explaining their operations, etc. However, although different machines are used for making the different kinds of knit goods and knitted fabrics, their separation into hard and fast divisions cannot be made, since the same type of machine that is used for making one kind of garment can also be used for making another kind, and the same machine can be used for making different fabrics by modifications of its operation or by using special attachments or devices. For convenience of explanation and description, however, the various types of knitting machines will be referred to, described and their operation explained in connection with the description of the knit goods or knitted fabrics that are made on them, the simpler types first and then the more complicated, with their special devices or attachments. As a study of knitting would be incomplete without reference to the various machines used in the different finishing processes and operations, for garments, etc., these will be taken up and their operation and applications explained in a succeeding chapter, completing the series of articles on knitting with a chapter on yarn winding and yarn winding machinery.

The peculiar characteristics of knit goods are their elasticity and their softness and evenness, hence they are particularly suited for underwear and hence their wide use for such purpose. However, it must be remembered that, although knitted fabrics are chiefly known to the public in their commoner forms of hosiery, underwear and knitted garments, this is only one development of the knitting machine, for it is capable of producing a variety of fabrics of great utility and beauty, either in imitation of more expensive woven goods or of an entirely original character, by various modifications of its operation or by the use of special devices or attachments. Examples of such fabrics are single and double plush goods, imitations of furs, etc., astrakan and bouclé cloth, crochet work, imitations of lace, etc. In some instances these fabrics can be produced on the knitting machine faster than on the loom, partly because of its simpler action and the nature of the fabric produced. Consequently, it is sometimes the case that a greater quantity of a fabric can be produced on a knitting machine at the same labor cost than can be produced by weav-

ing. The widest range of effects can be secured with the knitting machine, from a plain or ribbed fabric to the most elaborate designs in open or lace work, in a variety of stitches, alone or in combination, and goods can also be made in different colors, striped or variegated, or even of different textures and appearance on face and back, as in plated goods. Various garments can be made in any desired size or shape and these can be given almost any conceivable appearance by suitable manipulation of the various types of knitting machines designed for their manufacture, in which practically all the textile fibres can be used.

Returning to our subject, the classification of the products of the knitting machine, we can divide them into:

- (a) KNIT GOODS; and
- (b) KNITTED FABRICS,

the first referring to garments of any kind, and the second to knitted fabrics used either for making garments or for other purposes. These two divisions can be further subdivided into the following sections, respectively:

- (a) *Hosiery—Underwear—Garments for Outer Wear.*
- (b) *Fabrics Made Into Underwear—Fabrics Made Into Outer Garments—Fabrics Made for Other Uses Than for Making Garments.*

Each of these sections could be further subdivided, but for our purpose the preceding classification is all that will be necessary as all the various garments and fabrics made on knitting machines will fall under one or the other of these headings. The first of these sections being Hosiery, it will be taken up first and considered together with the types of machines used in its production.

Hosiery. The term *hosiery* includes stockings for women and children, men's half-hose, or socks, infants' socks etc., and also golf hose and other special styles and types of garments worn on the leg and foot. There are several classifications of hosiery, such as *opera hose*, an extra long stocking; *three quarters hose*, stockings that reach nearly to the knee; *trunk length hose*, which are longer than ordinary stockings but are not as long as opera hose, etc., all of which are trade names to distinguish certain kinds. *Tights* are a special kind of hose which combine stockings and drawers in one piece, made with or without feet, and fitting the leg very closely.

(To be continued.)

Pattern Mechanism for Standard Knitting Machines.

The object of this improvement is to be able to vary, in these machines, the combination of thread carriers used, to an unlimited extent.

ILLUSTRATIONS: Fig. A is a side view of a portion of a standard knitting machine, and Fig. B an enlarged detail (compared to Fig. A) of the new pattern device.

Previous to explaining the construction and operation of the new pattern mechanism, we will first refer to the main parts of the knitting machine itself, and of which 1 in Fig. A is the cam cylinder, and 2 the needle cylinder, having needles 3. The levers of the

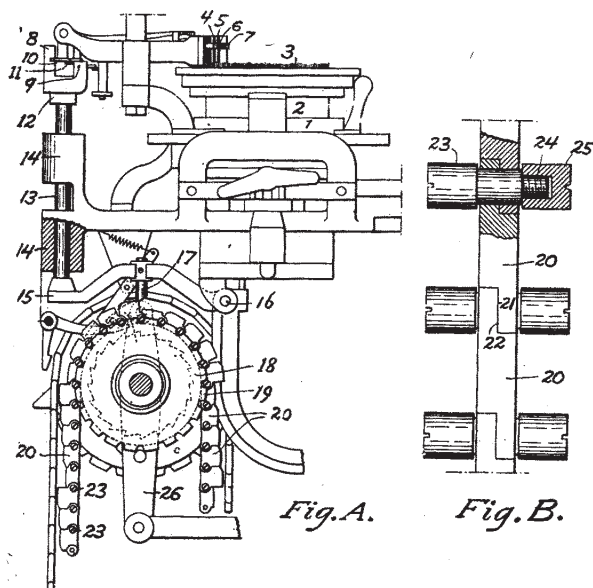

thread carriers are indicated by numerals of reference 4, 5, 6 and 7 and are operated upon by cams 8 and 9, which operate upon rollers upon the end of the levers at different heights, two rollers 10, 11 being shown in the illustration. These cams 8 and 9 are elevated to different heights to co-act with the different rollers and their corresponding levers and thread carriers, and are secured to a block 12 supported upon the rod 13 which is capable of vertical movement in guides 14. The lower end of this rod 13 rests upon the end of the lever 15, pivoted at 16 to the frame of the machine. Connected to this lever, between its pivot point and the rod 13 is the projection 17. 18 is a sprocket wheel having on each side of the sprocket, teeth 19.

THE NEW PATTERN MECHANISM, see Fig. B more in particular, consists of a plurality of blocks 20 having inclined upper cam faces, and said blocks are of different heights. Each block, at one portion of its end, has a socket 21 and at another portion an orificed projection 22 corresponding to the socket 21. They are associated together by a bolt passing through corresponding orificed portions of contiguous projections, said bolts having at one end an enlarged head 23 and a threaded opposite end 24, on which works a threaded holding nut 25, corresponding to head 23. By this arrangement a pattern device is provided with projecting blocks, which can be arranged in any desired relation with each other, said blocks occupying in the machine a positive and fixed seat on the sprocket wheel 18.

The projection 17 rests upon the surface formed by the blocks 20, and dependent upon the height of block immediately acting upon the projection 17 depends the position of cams 8 and 9. By this pattern device, by properly associating the blocks 20, chances for all the possible sequence or order of association of action of

the thread carriers is provided, also for any number of duplications of any given sequence.

Motion is imparted to this pattern mechanism in the usual manner, through the rocking lever 26 rotating intermittently (by means of details shown in Fig. A) the sprocket wheel 18. When this sprocket wheel is thus revolved, its teeth 19, through the medium of the bolts, pull the pattern device, composed of the blocks, around with it.

Finishing and Trimming Knit Mufflers.

The accompanying four illustrations show the manufacture of such a wearing apparel from the time that it leaves the knitting machine up to the garment, placed on the wearer; the affair referring to an improvement to what is known as "Way's Muffler" so named after its manufacturer.

In mufflers of this type, the entire article is constructed of vertically ribbed knit material, so as to possess great lateral elasticity, the entire garment being formed integrally from a single piece of fabric.

The novelty of construction aimed at is to secure for the neck or collar portion of such a garment, a downward flare, to correspond with the configuration of the human neck and shoulders, and to accomplish this without interfering with the tight fit and unfolded application of the muffler nor in any way increasing the liability of the garment to admit drafts at the sides of the neck.

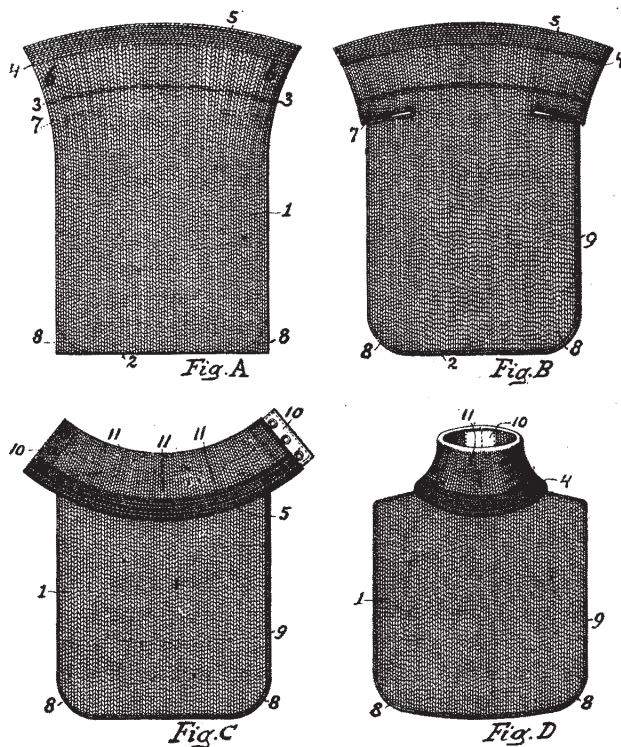

ILLUSTRATIONS: Fig. A illustrates the integral knit fabric from which the garment is made. Fig. B represents the garment after it has been cut and its edges seamed. Fig. C shows the completed garment lying flat, and Fig. D the garment as in place upon the wearer.

CONSTRUCTION OF THE GARMENT. The same is formed of a single integral web 1, of vertically ribbed knit fabric, corresponding in width to the desired width of the bib of the garment. The knitting is commenced at the bottom 2 and proceeds continuously until the line 3 is reached, when a single welt course is inserted. The knitting then proceeds, still of the same width until the line 4 is reached and where the character of the knitting changes, adding there in place of ordinary rib knitting, a series of from eight to twelve courses of rack stitches, until the upper edge 5 is reached. These rack stitches expand the knitting laterally very much more than the corresponding number of stitches of rib knitting, for which reason this edging of rack courses causes the entire upper portion of the garment and particularly the part which is to form the collar, to bell or flare outwardly as seen in Fig. A at 6. Two partial horizontal cuts 7, one at each side of the fabric, are then made, so as to form the upper edge of the bib, and to partially separate it from the collar, in order to permit its application of the body at the shoulders without puckering. The lower corners may be trimmed or rounded at 8, and when the fabric then is ready for edging.

At Fig. B the same fabric is shown when the cuts have been made and the entire edge of the integral garment over-stitched as indicated by the double line 9, extending from one upper corner to the other upper corner. The neck portion of the garment is then folded along the line of the welt course 3, so that it occupies the position shown in Fig. C. At both ends of the collar portion, facings 10 are then attached, and upon them the fasteners of the garment.

At the points 11, short lines of radial stitching are then made, so as to compel the collar portion to maintain its flat annular shape and its relation to the bib portion, without interfering in the least with its lateral elasticity.

The garment is thus completed, and when the collar portion is fastened at the back as shown in Fig. D, which illustrates its position when placed upon the wearer, possesses the advantages that without folding or creasing, the collar portion maintains a downward flare corresponding to the downward enlargement of the neck, without interfering with the flatness of the bib and its capacity to be applied to the chest of the wearer and tucked under the coat, without any fullness or puckering.

A Novel Manufacture of Stockings.

Colored stockings, it is claimed, in some instances, have been the cause of blood poisoning, especially where the skin of the foot of the wearer has become abraded. To guard against this:

- (1) Stockings having entirely white feet are made.
- (2) Stockings are made in which the heel, bottom of the foot and toe of the stocking are of white yarn.
- (3) Plaited stockings.

These three methods of manufacturing stockings in order to overcome the disadvantage of solid colored stockings, previously referred to, however, have their disadvantages, for instance the white foot, and the

white heel, sole and toe, as referred to in paragraphs 1 and 2, are objectionable, since white becomes easily stained and discolored from contact with the leather of the shoe and become unsightly, whereas a plaited stocking foot will never be of the full color as the main body of the stocking.

To overcome these disadvantages thus referred to, a Mr. G. H. Gilbert has just patented a process for making a stocking which has the desired uniform color on the exterior and yet has a white interior surface for the entire foot or such portion of the same as is desired. This, the inventor accomplishes in several ways:

(a) The stocking can be full dyed and then turned and the color on the inside to the extent desired discharged by a suitable discharge medium; or

(b) a stocking knit of colored yarn can have the surface on the inside to the extent desired discharged of coloring matter and restored to its original color; or

(c) The stocking can be knit of white material and then such parts of the interior surface as it is desired to have remain white may be printed with what is known as a *resist* and the stocking then dyed; or

(d) the exterior of the stocking may be colored by printing after the manner of printing calicoes.

Chemnitz Knit Goods.

Chemnitz is the world's chief producer of gloves, hosiery and knit underwear for foreign exportation, the chief rivals being the Nottingham district in England and the Troyes district in France.

The exportation of hosiery from Chemnitz to foreign countries, which began in 1820, according to the report of Consul Thomas H. Norton, and from which we quote, has grown to large dimensions. "Seventy American firms have resident agents at Chemnitz—frequently American citizens—purchasing and shipping hosiery, gloves and other textiles.

"The value of the export of hosiery from the Chemnitz consular district to the United States in the fiscal year ended June 30, 1907, was for cotton hosiery, \$7,098,967; silk hosiery, \$232,900, and woolen hosiery, \$50,749. The largest hosiery company in Chemnitz employs 1,000 operatives in three different factories. There are several establishments employing from 500 to 600. The average hosiery factory carries from 100 to 200 on its pay roll. A factory of 100 operatives produces from 30,000 to 40,000 dozen pairs of hose per annum.

"The preëminence of this section of Saxony in the manufacture of hosiery is not due to climatic conditions or the possession of trade secrets. An exceptionally high degree of energy and intelligence was manifested by the men who, during the last century, built up the industry. Their enterprise has been aided by a farsighted public policy, not only in the city of Chemnitz, but also in the smaller neighboring towns, of establishing admirably equipped and well-conducted trade schools, affording fine opportunities for training the youth in all branches of textile manufacture."

DYEING, BLEACHING, FINISHING, Etc.

TESTING OF CHEMICALS AND SUPPLIES IN TEXTILE MILLS AND DYE WORKS.

(Continued from page 171.)

(1) The Principles of Chemical Analysis and their Application, etc.

A few ideas of general chemistry must be first imparted to the student. This may be given by a few tests. Rub a glass rod vigorously with a piece of cloth, then touch particles of paper with it; the paper is attracted to the rod. No chemical change has taken place in the rod, it is still made up of the same kind of glass, yet it now possesses properties which it did not previously possess. Before it was rubbed, it did not attract the particles of paper. The glass rod after standing awhile ceases to attract the paper particles, but on rubbing it again, it will again attract the paper. A change of this kind, which is not permanent and which does not change the composition or make up of a substance is called a *physical change*. If we take a piece of wood and place it in a flame, it will take fire, become black, and if held in the flame long enough, it will burn to a gray ash. The piece of wood is changed to gases, which burn, to produce the flame and only ashes remain. We cannot recover the wood from these ashes, the wood has been permanently changed and moreover the ashes are not made up of the same chemical compounds as the piece of wood. A *chemical change has taken place*. On mixing finely divided copper filings with flowers of sulphur (pulverulent sulphur) there results an apparently uniform grayish-green powder. If this be examined, however, under a magnifying glass, we can very plainly distinguish the red metallic copper particles in it from the yellow of the sulphur; by treating with water, the specifically lighter sulphur particles can easily be separated from those of the copper. Carbon bisulphide will dissolve out the sulphur particles. Hence this powder represents nothing more than a *mechanical mixture*. If, however, this mixture be heated, *e. g.*, in a glass test tube, it will commence to glow, and on cooling, a black, fused mass remains, which differs in all respects from copper and sulphur, and even under the strongest microscope does not reveal the slightest trace of the latter, and treatment with water or with carbon bisulphide will not affect a separation of the ingredients. By the mutual action of sulphur and copper in presence of heat, a new body with entirely different properties has been produced, and is named *copper sulphide*. Mixtures of sulphur with iron or with other metals act in a similar manner; the resulting bodies are known as *sulphides*.

Such mutual action of different bodies occurs not only under the influence of heat, but frequently at ordinary temperatures. If, *e. g.*, mercury and sulphur are rubbed together in a mortar, there is produced a uniform black compound, called mercury sulphide.

In the previously described experiments we observed the phenomena of *chemical combination*; from two different bodies arose new homogeneous ones. The opposite may occur: the decomposition of compound bodies into two or more dissimilar ones. If red mercuric oxide be heated in a test tube, it will disap-

pear; a gas (oxygen) is liberated, which will inflame a mere spark on wood; in addition, we find deposited upon the upper, cooler portions of the tube, globules of mercury. From this we observe that on heating solid red mercuric oxide, two different bodies arise: gaseous oxygen and liquid mercury. We conclude, then, that mercuric oxide holds in itself, or consists of, two constituents—oxygen and mercury. This conclusion, arrived at by decomposition, or *analysis*, may be readily verified by combination or *synthesis*. It is only necessary to heat mercury for some time, at a somewhat lower temperature than in the preceding experiment, in an atmosphere of oxygen, to have it absorb the latter and yield the compound we first used—red mercuric oxide. The direct decomposition of a compound body into its constituents by mere heat does not often happen. Generally, the coöperation of a second substance is required, which will combine with one of the constituents and set the other free. In this manner we can, for example, effect the decomposition of the previously synthesized mercury sulphide, *viz.*, by heating it with iron filings, the iron unites with the sulphur of the mercury sulphide, to form iron sulphide, while the mercury is set free.

In analysis, bodies or substances are finally reached which have withstood all attempts to bring about their division into further constituents, and which cannot be formed by the union of others. Such substances are chemical *elements*. Their number, at present, is about 70; some have been only recently discovered. To them belong all the metals, of which iron, copper, lead, silver, and gold are examples. Other elements do not possess a metallic appearance, and are known as metalloids or non-metals. To these belong sulphur, carbon, phosphorus, oxygen, etc. The line between metals and non-metals is not very marked. Thus, mercury, despite the fact that it is liquid at the ordinary temperature, must be included among the metals because of its chemical properties.

All the substances known to us are made up of these elements. Water is a compound of two gaseous elements—hydrogen and oxygen; common salt consists of the metal sodium and the gas chlorine. The elements make up not only our own earth, but the stars, moon, sun etc., are composed of them.

The Principle of the Indestructibility of Matter. If the total weight of substances, which are to act chemically upon one another, be determined, and the chemical action be then allowed to occur, it will be discovered upon ascertaining the weight of the resulting bodies, if due consideration be given for unavoidable errors of experiment, that no loss or increase in weight has occurred—no change in mass, because mass and weight are strictly proportional to each other for one and the same place. It is in these cases immaterial whether a compound body be resolved into its elements, or whether elements unite to produce compound bodies; the products present after the chemical reaction will always weigh exactly what the bodies preceding the reaction weighed. Well-known, general phenomena apparently contradict this scientific conclusion. We observe plants springing from a small germ and

constantly acquiring weight and volume. This spontaneous increase of substance, however, is only seeming. Close inspection proves conclusively that the growth of plants occurs only in consequence of the absorption of substance from the earth and atmosphere. The opposite phenomenon is seen in the burning of combustible substances, where an apparent annihilation of matter takes place. But even in this, careful observation will discover that the combustion phenomena consists purely in a transformation of visible solid or liquid bodies into non-visible gases. Carbon and hydrogen, the usual constituents of combustible substances, *e. g.*, petroleum or wood, combine in their combustion with the oxygen of the air and yield gaseous products—the so-called carbon dioxide and water—which diffuse into the atmosphere. If these products be collected, their weight will be found not less, but indeed greater, than that of the consumed body, and this is explained by the fact that in addition to the original weight they have had the oxygen of the air added. Such a combustion must, therefore, be regarded as a conversion of visible solid or liquid substances into invisible gaseous matter.

The production (creation) or annihilation of matter has never been demonstrated as occurring in any change. A compound body is composed of certain elements, and contains a very definite quantity by weight of each of them. If it decomposes it naturally breaks down into its constituents, which perhaps reunite in some other manner to form new compounds; always, however, preserving their original nature, their original weight and their masses. This fundamental truth is the law of the indestructibility of matter.

All bodies can be divided into infinitely small parts, no longer recognizable by sight or taste. Invisible aqueous vapor separates from the air as water upon cold objects and again disappears on the approach of heat. The ring that is constantly worn on the finger becomes thinner in the course of years. Dropping water wears away the stone. The smooth pavement is made rough by walking. All these things occur without our perceiving what at any one time departs from the ring, etc. Hence we conclude the bodies are composed of invisible, extremely small parts, which to us are without mass. These particles, the atoms, are indestructible and cannot be created. The difference in things is due to the difference in number, size, form, and arrangement of the atoms.

We assume that an element consists of atoms perfectly similar to one another, but differing from those of other elements. There are as many kinds of atoms as there are different elements. A compound body, like iron sulphide, according to this view, is produced by the combination of sulphur atoms with iron atoms in a definite ratio. Those particles of a compound representing the limit of divisibility so far as similarity goes, are called *molecules*, which by further division are resolved into dissimilar parts. Hence, iron sulphide is made up of molecules, which in turn consist of atoms of iron and of sulphur. One hundred parts of the previously mentioned iron sulphide consist in

round numbers of 63.6 parts of iron and 36.4 parts of sulphur. If, however, there is in this compound one atom of sulphur for one atom of iron, then the atomic weights of iron and sulphur must be to one another as 63.6:36.4. The ratios between the atomic weights of the elements may be determined in this manner. If for any element a number be taken for its atomic weight, it can be readily calculated in what ratio the atomic weights of all the other elements stand to this arbitrarily chosen standard, and we thus obtain the relative atomic weights. That element which combines with the majority of the other elements to form compounds, capable of the most accurate analysis, is chosen as the standard of comparison.

Chemical Symbols and Formulas. The chemical elements are simply and conveniently represented by the initials of their Latin or Greek names. Thus hydrogen is designated by the letter *H*, from the word hydrogenium; nitrogen by *N*, from nitrogenium. Elements having the same initials are distinguished by adding a second letter; thus, *Na*, indicates natrium (sodium), *Ni*-nickel, *Hg*-mercury (from hydrargyrum), *Cr*-chromium, *Al*-aluminum, etc.

Chemical analysis, to the extent at least in which it is treated of in this article, is essentially an art, inasmuch as it is the application of the recognized principles and facts of chemical science to the solution of questions of more or less frequent recurrence and practical utility. The general object of analytical operations is to ascertain the chemical nature of substances; their special object may be either to ascertain what are the elements of which a substance consists and what their state of combination; or, these particulars being known, to learn their relative proportions.

This analysis is either *qualitative* or *quantitative*. It may sometimes be desirable in both instances to extend the examination to all the elements contained in a substance, however small their proportion; sometimes it will only be necessary either to ascertain the presence or absence of some one or more elements or compounds, or to estimate the proportion of some particular constituent of the substance examined.

Complete and minute analyses of the former kind belong almost exclusively to the more purely scientific portion of chemistry, those of the latter kind relate to the technical applications of chemistry and are used for the purpose of determining certain points which have a commercial or technical importance, rather than any direct bearing upon the cultivation of science.

The chemical nature of any substance is always ascertained by subjecting it to certain treatment called the *test*, and the presence of any element or compound is indicated by the consequent production of some change, generally through the agency of some other substance, and always under certain definite conditions. This change, which is called the *reaction*, usually consists in the formation of a compound of the substance sought, possessing marked and distinctive peculiarities. The substances used for this purpose are called *reagents*. It is, of course, essential that the criterion by which we judge of the presence or absence of any element or compound should be in-

fallible, and if there should be any exceptions to its general applicability, the conditions upon which they depend must be understood and provided against.

When the substance to be examined contains a great number of elements in various states of combination, its behavior with reagents, which would otherwise indicate their presence, would in many instances be so modified or disguised as to render their detection extremely difficult and tedious. In order to obviate the inconvenience which would result from such a circumstance, the elements have been arranged in several analytical groups, according to general analogies, obtaining, either between the conditions under which they yield compounds of particular types, or in the behavior of their compounds with certain reagents, and of such a nature that the application of a particular test will at once indicate either the absence of a whole group of elements, or the presence of some or all of its members. By a systematic application of such tests it is possible, not only to learn what groups the elements of any substance belong to, but likewise to separate these groups, and thereby greatly facilitate the special recognition of the individual elements. This will be described in part II under General Method of Testing Chemicals.

(To be continued.)

PRACTICAL POINTS ON THE SHEAR AND THE SHEARING OF WOOLEN AND WORSTED GOODS.

(Continued from page 89.)

The rubber rest. The same is built either with the list saving attachment or plain, and is used more particular only for the closest kind of shearing on hard face goods like worsteds and in connection with running goods on backs, in order to save back-burling. The object of this soft edge is to prevent knots, if present on the back of the goods, from lifting the cloth at such points into the path of the shear blades and causing injury (shear marks, holes, etc.) to the cloth, since the softness of the rubber allows the knots to sink into it, and in this manner the face of the fabric under operation is not raised. With the rubber rest, the metallic part of the rest, both the solid part as well as the pieces of the list motion (if this attachment is used) is grooved sufficiently to receive a rubber tube, and after the same is placed in the groove, an apron of tracing cloth is passed over the tube as a protector and to keep it in position. The metallic part of the rest is flexible, that is to say, it can, by means of screws, be adjusted, which is necessary on account of the more or less unreliable nature of rubber, of which the tube is composed. By having the rest made flexible, there will be frequent occasions when the rest needs to be trued up. To keep the rest perfectly true at all times is an impossibility, but it is a fact that any unevenness in the rest is not as likely to produce bad results as an unevenness in the steel rest would do. The operator may have the rest perfectly true when he starts a piece, but he cannot be sure that it will be true by the time the piece is finished. The rubber tube is raised or lowered by means of compression or expansion, which is done

from the side. In order to raise the tube, the groove is compressed, or made smaller, while, when the groove is expanded or made larger or wider, the tube is lowered. The metal part of the rest remains in the same position all the time, and any unevenness of the surface of the rubber rest must be thus remedied as explained before. The tube is about three-eighths of an inch in diameter, the thickness and also the degree of hardness of it varying according to the cloth to be sheared. Some use a tube with very thick walls while others use a tube with very thin walls, and some of them use either one of these kind of tubes composed of very hard rubber while others prefer very soft rubber. It depends altogether on the finish required and the goods sheared.

The whole final object in view in the selection of a tube is, of course, to have the knots or lumps on the back of the goods bury themselves into the soft surface of the edge of the cloth rest and yet raise the pile or nap of the goods into the path of the blades of the shear cylinder. Experience will show best the kind of tube wanted. The rubber rest is now very largely used to *running the shear on backs*, which means pushing the knots as on the face of the goods, through the cloth, into the back, then running the goods over the rubber rest, face down, and shearing the back. This takes all of the knots off the back of the goods that were there in the first place and also those that have been pushed through from the face of the goods.

After the fabric has been thus sheared on the back, it then can be sheared on its face, over a regular steel rest, because the back has been cleaned from knots and lumps and consequently no chance for shear marks.

Since rubber and oil are antagonistic to each other, the operator must be careful to keep the tube free from oil, since if the latter should come into contact with the rubber, the first thing to be noticed is an increase in the size of the tube, due to swelling. Although this would seem like a small item, yet it is often enough to make the tube useless. Oil, when it does get on, generally gets on the list motion, causing the tube to swell at that point, and thus making the part of goods, passing over those places, shear closer there than on the other part of the goods, and if allowed to get worse, the selvage will be cut. To a certain extent, the evil can be remedied by adjusting the motion, although this is only temporary, so that it is best to replace the tube with a new one.

Provided the tracing cloth apron which is put on over the rubber rest, (unwinding from one roll onto another), is damaged from any cause, the rubber tube which is somewhat compressed by it, will come through, and the cloth, being operated on and running on top of this, will be cut as a result. For this reason the apron must be very closely watched, and should not be allowed to have too many pieces of cloth pass over it before its position on the rubber rest is moved, the reason for this being that the cloth under operation comes in contact with the apron for not quite half an inch, and will therefore wear only at that part, but if the apron is moved so as to subject a new surface about

twice or three times a day, there will not be much danger of its breaking. When shearing coarse and wiry goods, it will be necessary to move the apron after every two or three pieces of cloth have passed over it, in order to keep the apron from wearing through quickly at the one working surface. This changing of position of the apron is readily done by slightly turning the rollers upon which said apron is winding and unwinding itself.

When replacing old tubes, care should be taken to see that the new tube to be put on, is of the required diameter, since the groove in the rest is of a definite size, and if the new tube is slightly larger, it must be pressed into the groove, which, however, is not so bad as if the tube were too small, because in the former case, after the apron has been put on, there will be no trouble, but in the latter case, the tube being too small for the groove, the same is liable to rest against one side of the groove at one place and another side at some other place, thus producing an uneven surface for the cloth. When a smaller tube than the required size has to be used, it is a good plan to apply a thin coat of glue to the groove and then place the tube in it, keeping said tube pressed evenly down (leaving the cylinder down on it lightly, just enough to hold the tube in position) until the glue hardens; however, the best plan in all cases is to have the tube of the right size.

A feature in favor of the rubber rest shear is, that when the same is intelligently handled, there is little, if any, chance for holes to be made, and it is only when the person relies on the rubber rest to do everything that damage will be done.

On account of the rubber tube, as placed in the rest of the rubber rest shear, it is necessary to bring the cutting mechanism down to the cloth in such a way that the ledger, as well as the revolving blades are brought down on the top of the cloth, thus forming very nearly a correct right angle, or 90 degrees, instead of meeting it, as is the case with the steel rest, at an angle of about 45 degrees, and the cutting point is found at the corner of the angle. Care is required to get the blades in the right position with reference to the rubber tube, for, if they are not placed in the proper position, the rubber rest is sure to be more of a source of damage than a help. Fig. 5 shows this rubber rest in section, showing also position of ledger blade and shear cylinder, as well as the list saving device applied. Letters of reference in the illustration indicate thus: *A* rubber tube, *B* the run of the cloth through the shearing mechanism, *C* the apron as passing over the rubber tube in order to protect the latter from wear as well as to keep it properly in place. The ledger blade, shown shaded, is placed towards the shearing point at an angle of nearly 90°. *D* is the feeler catch roll of the list saving device.

Besides the rubber rest thus explained, we also meet with specialties of rests, known as *The Felt Pad Rest* and the *Hollow Edge Rest*.

In connection with the first, a cushion formed of felted fibre is interposed between the cloth rest and the fabric under operation, and when knots and other

imperfections in the fabric will cause the cushion to yield locally, so that an even surface of the cloth is maintained, and the nap is shorn evenly.

The principle of the hollow edge rest in turn will explain itself at once to the reader without any special comment on it, the hollow edge in this instance taking the place of the rubber tube in the rest.

(To be continued.)

An Improvement to the Sargent Wool Washer.

The improvement refers to the devices which are employed at the delivery-end of the bowl of a wool-washing machine for the purpose of discharging the wool from the said bowl. This as will be readily understood relates to the reciprocating toothed carrier by means of which the wool is pushed upward along the inclined table at such end of the said bowl adjacent to the squeeze rolls, and delivered on to the surface of the lower one of said rolls.

In machines until now built, the leading end of the carrier is provided at each side thereof with a truck or roll which rests upon a fixed guide which is located at the side of the bowl. In some cases the carrier is constructed with a transversely-extending rod having a truck or roll such as aforesaid mounted upon each of its opposite end-ports. By means of the truck or roll at each side thereof, and the fixed guides, the said leading end of the carrier is supported and guided as the carrier reciprocates. The carrier is operated by means acting to cause the body of the same to occupy a raised position clear of the wool in the bowl during the return movement of the carrier toward the middle of the length of the bowl, and to occupy a lowered position in engagement with the wool in the tank during the advancing movement of the carrier toward the squeeze or press-rolls. This raising and lowering of the said body is produced by causing the carrier to rock or swing in a vertical plane upon the trucks or rolls. This swinging or rocking movement of the carrier operates to move vertically the swing-teeth with which the carrier is furnished at the leading end thereof, and thereby the said swing-teeth are caused to recede bodily from the surface of the inclined table and approach the same again, as the carrier travels along such table.

The general object of the Sargent improvement is to provide a construction of carrier by which the tendency to bodily movement of the swing-teeth at the leading end of the carrier is obviated, and by which the swing-teeth in question are enabled to move in a path which at all times is parallel with the surface of the table.

BLEACHING WOOL, WOOLEN YARNS OR SHODDY WITH SODIUM PEROXIDE.

BLEACHING with sodium peroxide consists of obtaining an alkaline solution of hydrogen peroxide, and then, by the action of the fibre, a liberation of an atom of oxygen from each molecule of the hydrogen peroxide solution. The oxygen is in a nascent condition and attacks the coloring matter present, and oxidises it to a colorless body. A great deal of the success and usefulness of the process depends upon the nature of

the coloring matter present in the fibre. Natural wools have a slight yellow tint, and a darker yellow tint in some of the fibres, in natural grey wools brown and black fibres are mixed with yellow ones.

In shoddy goods there is the coloring matter with which the material has been previously dyed, and it is not possible to remove much color from any material which had been dyed with indigo, or from any in which an oxidising action had been used in the previous dyeing operation. Very good results can be obtained from any material which has been dyed with acid dyes. In any case a small sample of the material can be tried to judge if it will pay to bleach with sodium peroxide.

With natural wools the best results are obtained with the yellow fibres; the coloring matter in these seems to be more easily oxidised than in the grey wools. In the brown and black the color can be removed, but it finally costs more for bleaching than the purchase of a better sample of wool in the first instance. However the brown fibres can be oxidised to a light yellowish brown, and the black fibres will give a dark brown. With shoddy goods, a much better result is obtained if they are given a preliminary stripping with ammonia; this seems to loosen the coloring matter. One great advantage of the peroxide bleach is that it does not affect the lustre of the wool; if anything, it tends to increase it.

The bleaching can be done in a wooden vessel and this must be heated with a lead coil. If an open steam pipe is used, the liquor is liable to become contaminated by impurities out of the pipe, and also any impurities in the steam. Copper must not enter the bleaching bath because there is a probability of copper salts forming, and if any of these are present the oxygen will be liberated at an abnormally high speed, thus causing a great waste of available gas. Iron must not be allowed in the solution because this forms brown iron salts which stain the material. All sodium peroxide contains a small percentage of iron, as the apparatus used in the manufacture is made of iron. Now, if this is allowed to go into the solution in an uncombined condition, after the bath has been used a few times, there will be sufficient iron present to cause a discoloration of the whole bulk of the material. To remedy this, sodium phosphate is added, in the proportion of about $\frac{1}{2}$ oz. phosphate to every lb. of peroxide. The phosphate combines with the iron to form a soluble salt, thus keeping it in solution, and at the same time in a harmless condition.

To make up a very useful bleaching solution, a good proportion is to take, for every 600 gallons of water,

10 lb. sulphuric acid (168° Tw.),
7 " sodium peroxide,
 $\frac{1}{4}$ " sodium phosphate.

The sulphuric acid and sodium phosphate are first put into the water, and the sodium peroxide is gradually added with constant stirring. With the above proportions the bath will be found to be about neutral; if it should be still acid a good plan is to add small quantities of sodium peroxide until it is just alkaline,

and then make it acid by the addition of dilute sulphuric acid.

The bath is gradually warmed up whilst the sodium peroxide is being added; this facilitates solution. The bath is now given a good stirring for a few minutes and then allowed to stand for 5 or 10 minutes; this is necessary to be sure that all the sodium peroxide is dissolved, otherwise if any gets on the material in an undissolved condition, it will cause it to become tendered.

A white scum will have formed upon the surface of the solution. This is carefully removed, and then sufficient alkali is added to make the bath alkaline. The degree of alkalinity can be regulated in conjunction with the temperature of the bath; the hotter the solution the less the degree of alkalinity. The best temperature to work is between 120° and 160° F. In all cases the bath must always be alkaline when being used. The alkalies generally used are silicate of soda, ammonia or borax. One great objection to using silicate is that after the bath has been used, upon making it acid for the following batch, an insoluble precipitate of H_2SiO_3 is thrown out, which spoils the bath. Ammonia is rather quick in its action and causes the oxygen to be liberated rather quickly. Borax is very weak, but has neither of the objections that apply to silicate and ammonia, but it can be used to advantage by mixing it with ammonia.

Having made the bath the required degree of heat and alkalinity, the material is now put in as quickly and evenly as possible, and then pushed well under the liquor. It is then fastened down by means of a light wooden frame. This must be at least two or three inches below the surface of the liquor; otherwise, if any of the material becomes exposed, stains are the result. The same thing occurs if the vat and cover are allowed to get dirty.

The vat may be covered with a heavy piece of canvas to keep in the heat. If the material is put in overnight it will be ready for taking out next morning. The material must be thoroughly cleansed from all soap, otherwise it will be impossible to use the vat continuously. To keep the bath till it is next required make it slightly acid, and, of course, bring it up to strength immediately before it is to be used.—"*Sodio*" in *The Dyer and Calico Printer*.

An Improved Process of Dyeing Cotton with Sulfur Dyestuffs.

As is well known, sulfur dyestuffs show the disadvantage of dyeing uneven shades.

In French Letters Patent No. 367,921, a process for dyeing vegetable fibres with sulfur coloring matters is described, which process consists in dyeing with these dyestuffs in baths prepared in the usual way with the aid of alkaline sulfids and sulfur coloring matters, but with the addition of ammonium salts. By this process level and uniform shades are obtained, which in many cases are even deeper and faster to washing than those obtained without the employment of ammonium salts.

The *Farbenfabriken* of Elberfeld, the prominent

manufacturers of Dyes on the Continent, have now found that this favorable action of the ammonium salts seems to be due to the fact that the ammonium salts neutralize the free alkali present in the alkaline sulfid dye bath and that metal salts capable of binding alkali will produce the same result. These metal salts are generally added to the baths in such quantities that a distinct smell of hydrogen sulfid is evolved, but care must be taken that no dyestuff or leuco-compound is precipitated. The new process is also suitable for dyeing by machinery.

In order to illustrate the new process more fully and which, as will be readily understood, is protected by Letters patent by the Elberfeld Co., in this country, the following example is given: A dyebath is prepared from 2000 parts of water, 10 parts of Katigen indigo R L extra, 10 parts of crystallized sodium sulfid, and 20 parts of Glauber's salt. To this dyebath 5 parts of sodium bicarbonate are added, and 100 parts of cotton yarn are then dyed in this bath at 50 degrees C. for $\frac{3}{4}$ hour. The dyed goods are squeezed out, exposed to the air and rinsed.

The process is the same for other dyestuffs and for other metal salts capable of binding alkali, such as bisulfate of sodium, bisulfite of sodium, alum, acetate of aluminium, tartar, etc. The quantities to be taken, ought to be sufficient to neutralize the free alkali, but care must be taken not to add an excess and to avoid the precipitation of the dyestuff.

New Chromate Process-Dyes.

Manufacturers of fancy worsteds have experienced unusual difficulties this season in obtaining satisfactory dyeing in the mode shades of olives, drabs and slates now in vogue. Early in the season worsted yarn spinners were held responsible for these conditions, the uneven dyeings obtained being attributed to the use of unsuitable stock or to abnormal conditions in the manufacture of the yarn. Yarns from various spinners behaved in a similar manner in dyeing, while dyeings on the finer quality yarns presented greater difficulties, those on the coarser qualities were also badly defective. Experienced dyers say that the neutral or mode shades so largely in use this season have always been difficult to dye level, and especially so when dyed by the known processes for producing fast colors suitable for the high-class fancy worsted trade.

The timely introduction of a new class of dyes and a special method of application, known in the trade as the Chromate process, seems to have overcome all the difficulties experienced, making it as easy and certain to produce level dyeings in these shades as in any others, whether on yarn, pieces or other work. Manufacturers who are now successfully dyeing by this method report most satisfactory results, the colors being perfectly even and solid, while the stock is left in far better condition than with the older methods, and the colors so produced are entirely free from the disagreeable reddening in artificial light. The chromate process is a strictly one-bath method, yet it produces colors that have all the properties of fastness to washing, fulling and light that is required in the highest

class goods. Combining as it does all the good properties of all known processes with apparently none of their defects, it seems destined to become the standard process for the production of fast colors. From the beginning of the dyeing operation the tone of the resulting shade is maintained, so that constant control of final results is readily preserved. This point is most valuable as it has been a serious objection and difficulty heretofore met with in efforts to work out the problem, which has found its solution in the new Chromate colors.

This process was first tried out in New England at the Earncliffe Worsted Mills, and so favorably was the company impressed with the results achieved that its use was taken up in the middle of the last light-weight season and has been continued ever since. Superintendent Robinson is very enthusiastic over this new class of dyes and states that it saves about fifty per cent in time, and an evenness in shade can be obtained not possible in the ordinary systems.

NEW DYES.

The Farbenfabriken of Elberfeld Co. have in addition to their Acid Chrome Blue B, now put on the market two more brands of this class of dyes, viz:—

Acid Chrome Blue B R and 2 R.

These dyestuffs are either dyed in an acid bath and after treated with bichrome, or dyed on a chrome bottom, the latter method producing shades of a somewhat redder tone. *Acid Chrome Blue B R* produces a pronounced dark blue, *the 2 R brand* a more reddish blue. The new brands are remarkable for their very good level dyeing property, excellent fastness to milling, carbonization and light, as well as for their good fastness to steaming and potting. These valuable properties render the products highly adaptable for the dyeing of fast dark blues and as combination colors for the production of fashionable shades in olive, brown and green on loose wool, slubbing, yarn and piece goods.

In combination with the various Acid Chrome Blue brands, the most fashionable blue shades of excellent fastness can be easily obtained. White cotton checking threads are not tinged. Both new colors are, as the B brand, well adapted for printing on slubbing with acetate of chrome, chromium formate or fluoride of chrome. The prints are very fast to fulling and hot water.

DIRECTIONS FOR DYEING:

One bath process. Add to the bath
10-20% Glauber's salt cryst.
2-3 % acetic acid

and the dyestuff previously dissolved, enter the material at 160-175° F., bring slowly to the boil, boil for $\frac{1}{2}$ hour, and then add 1% sulphuric acid. When the color is absorbed and the liquor left fairly clear, treat the goods for 30-40 minutes at the boil with half the amount of bichrome (of the weight of the color employed). When dyeing in copper vessels it is advisable to add an addition of sulphocyanide of ammonia (1 oz. per 25 gallons).

¹ *Two bath process.* Mordant as usual with bichrome and tartar or in place of the latter other mordanting agents and dye with the addition of 1-2% acetic acid and 10-20% Glauber's salt.

Katigen Indigo 2 R L extra, is another new brand of dyes brought in the market by the Elberfeld Co. The same is handled and dyed in the same manner as their other Katigen Indigo brands, but, in comparison to the latter, is remarkable for its considerably more reddish and brighter tone. The dyestuff yields shades of such excellent properties, that only when exceptionally high demands are made on fastness to boiling is an after treatment with bichrome and copper sulphate necessary, which process causes the shade to appear somewhat redder and duller.

Katigen Indigo 2 R L extra is recommended for the dyeing of loose cotton and yarns for plain and fancy woven goods which have to be fast to washing, etc., also for cops and cheeses in machines as well as for linen and half linen yarns and fabrics.

DIRECTIONS FOR DYEING: Dissolve the dyestuff with double the amount of sulphide of soda cryst. as color taken, add this solution to the bath containing soda, boil up, then add the common or Glauber's salt and dye for about 1 hour immersed in the liquor at 140° F. After dyeing, wring out uniformly, hang up and finally rinse.

By an addition of Katigen Intensifier B, deeper shades are obtained, *i. e.*, shades of a certain depth can be obtained with less dyestuff than is required when employing the usual method in general use. Dissolve Katigen Intensifier B in luke-warm water, or better still sprinkle same in the powder form on the liquor, which should not be above 105-120° F. An addition of soda is only necessary for the first bath to correct the water. Then dye and treat further, as mentioned before.

Diamine Bengal Blue G and R are two new products of the Cassella Color Co., and which possess the same good properties as their Diamineral Blues which have proved of such excellent value to our dyeing industry, surpassing the latter, however, in brightness of shade.

Like Diamineral Blue, Diamine Bengal Blue G and R come into consideration for direct dyeings and also for an aftertreatment with sulphate of copper and bichromate of potash.

They possess the special property of *exhausting most excellently* and are on this account exceedingly well suited for producing dark blue shades on loose cotton, yarn and piece-goods.

Diamine Bengal Blue G and R may also be used for the dyeing of half-wool and half-silk goods; the "G" brand especially yields solid shades on animal and vegetable fibres.

Washed along with white cotton, they stain the latter but slightly in pale shades, a little more so in deep shades.

Acetic acid of 50% strength reddens the shade of

Diamine Bengal Blue G, but on washing the original shade returns; the "R" brand is not affected.

Hot pressing slightly reddens both brands, the original shade returning however after cooling.

Diamine Bengal Blue G may be used for white and colored discharges, Diamine Bengal Blue R on the other hand only for colored discharges.

METHOD OF DYEING:

COTTON: Dye at the boil, in the manner customary for Diamine Colors, with the addition of $\frac{1}{2}$ —1% soda and 10—20% desiccated Glauber's salt or common salt, according to the depth of shade to be dyed.

UNIONS (Half-Wool): Dye boiling hot in a neutral Glauber's salt bath (containing 2 lbs. desiccated Glauber's salt per 10 gallons liquor).

SATIN (Half-silk): Dye to best advantage boiling hot with the addition of $\frac{1}{2}$ to 1 lb. desiccated Glauber's salt and 3—4 $\frac{1}{2}$ oz. soap per 10 gallons liquor.

Address their New York office 182 Front Str. for a color card, containing eight samples of dyed loose stock, yarn and cloth.

In addition to the Naphtogene Blue 6 R brought out a few months ago, The Berlin Aniline Works are now introducing into the market a new and likewise uniform brand of this group of dyes under the name of NAPHTOGENE BLUE B which, when diazotised on the cotton fibre and developed with Beta-Naphtol yields indigo blue shades of good fastness to washing and light.

Naphtogene Blue B is well adapted for all branches of fast dyeing on cotton: raw cotton, yarn in hanks, cops, bobbins, piece-goods, etc., also applicable for all other vegetable fibres, owing to its being easily discharged, the dye is of special interest for cotton discharge printing.

For Direct Dyeings: Naphtogene Blue B is rather less easily soluble than the other Naphtogene Blue brands. For dissolving and dyeing soft water must be employed. Cotton, flax and other vegetable fibres are dyed in a boiling bath with an addition of about 20% Glaubersalt calc. (or common salt) and 1% soda ash; the dye-baths are almost exhausted. The dyestuffs can be dyed in copper vessels without fear of affecting the shade; iron influences the shade a little. The direct dyeings yield dull blue shades possessing little interest.

Dyeings Diazotised and Developed with Beta-Naphtol: The direct dyeings are rinsed slightly and treated for $\frac{1}{4}$ — $\frac{1}{2}$ hour in a cold Diazotising Bath, containing for 10 lbs. cotton 5 oz. nitrite of soda and 10 oz. sulfuric acid (168° Tw.). Then rinse and enter into the cold Developing Bath, containing for 10 lbs. cotton 1 $\frac{1}{2}$ oz. Beta-Naphtol, dissolved with an addition of 1 $\frac{1}{2}$ oz. caustic soda (76° Tw.). Treat for $\frac{1}{4}$ — $\frac{1}{2}$ hour, rinse, soap if desired, and dry.

Discharging: The dyeings can be discharged white with Rongalite C and the other usual reduction discharges.

Samples of Yarn and Cloth dyed with Naphtogene Blue B can be obtained by applying to their New York office, 213 Water Street.

TEXTILE ENGINEERING

THE LIGHTING OF TEXTILE MILLS.

(Continued from page xii of December Journal.)

The term "candle-power" is used to describe the light power of a source of illumination, being based on the amount of light emitted by a candle of standard weight and rate of burning. Thus, in speaking of a 32-candle-power lamp, we mean that this lamp has a lighting efficiency equal to that of 32 standard candles.

A new type of incandescent lamp which promises great improvements over the present type are the so-called "metal filament" lamps, in which the well-known carbon filament or thread is replaced by a fine wire of a metal of high melting point and good electric resistance, such as tungsten or tantalum, rare metals, which only lately have been available in commercial quantities. The tantalum lamp is now on the market, and while its cost is considerably more than the carbon lamp, there is a much greater economy in power consumption, light given off, life or hours it remains effective, etc. The light from the tantalum lamp more nearly approaches daylight than does the carbon lamp, it is whiter, more intense and is less affected in penetrating power by reflection and refraction. When cheapened in cost, the tantalum lamp will be the best type of incandescent lamp for textile mills.

Vapor Lamps. There are two types of the so-called "incandescent vapor lamp," in one, the Cooper-Hewitt and Bastian lamps, the light is given off by incandescent mercury vapor; in the other, the Moore lamp, the light is from a non-metallic gas. In both cases the light is obtained by passing an electric current of high intensity through an air-exhausted tube containing either mercury vapor or a gas, these being brought to incandescence by the rapid oscillations of their atoms due to the effect of the electric current. These lamps are made in the form of glass tubes an inch or more in diameter and of different lengths. The Cooper-Hewitt lamp is seldom more than three to six feet in length, and is straight; the Moore lamp has been made from three feet up to 155 feet long and the tube can be bent or made in portions of any angle, to extend around the four sides of a room, for example, or it can be made circular in form.

The light from these lamps is remarkably soft and diffused and closely resembles daylight in this quality, the details of objects being very clearly defined and there being almost a complete absence of shadows. The Cooper-Hewitt lamp gives a peculiar greenish-white light, in which red rays are entirely lacking, hence it cannot be used where it is necessary to match or use colors, anything colored red appearing black in its light, other colors, however, showing fairly well. The Bastian mercury lamp has no special light, but is also lacking in red rays. The Moore lamp gives a pink light, as viewed from a distance, but actually its light closely resembles sunlight in its effects on colors. It can be used anywhere that other lights are employed as far as this effect is concerned, while its light is much more pleasant than that of the mercury-vapor lamps.

Both the Cooper-Hewitt and the Moore lamp are being widely used where a soft, uniform diffused light is required rather than light concentrated in a restricted area. Unquestionably, they are the ideal lamp for illuminating textile mills, and the only objection against them, at present, is their first cost, as they are very cheap to maintain and require practically no attention. Either lamp will operate on an alternating current of 110 to 220 volts, or the Cooper-Hewitt lamp can be operated with a direct current of 50 to 100 volts. The average "life" of the lamps is about 2000 light hours, that is 2000 hours of actual use.

The proper way to illuminate a room with these lamps is to have them extend around the four walls carried on brackets near the ceiling, reflectors being placed behind them to throw the light out and down. A room so illuminated would be filled with a soft, clear, diffused light, almost exactly like daylight, every object in it would be equally and uniformly illuminated, there would be no dark shadows anywhere and fine details could be seen as plainly as by daylight. In fact, the room would not appear to be artificially lighted at all, and one would scarcely notice the light-tubes unless their attention was called to them. No other artificial light can equal this method of illumination in efficiency and economy of light obtained from an equal consumption of electric current. There is practically no waste of current in heat, the tubes remain cool and most of the electric energy is transformed into light without heat.

A spinning room, for instance, could also be lighted by these lamps by suspending 3 to 6 feet length tubes horizontally over the machines, placing reflectors over them. Even this method is far superior in light effect to any other form of electric lamp and consumes less current than arc lamps.

If it were practical under the ordinary conditions of textile mills, the best and most satisfactory illumination could be obtained by reflecting all the light downwards from the ceiling, arranging the lamps so that all their light would be thrown up to a smooth, glossy, white ceiling and by that be reflected downwards and diffused equally all over the room. A room lighted by this method would be equally light in all parts, the effect would be that of daylight and there would be no dark shadows or unlighted places.

The same effect would be secured by the use of the mercury vapor or gas lamp, as previously mentioned, the glass tubes being placed around the walls of the room close to the ceiling. With this system of lighting by reflection from the ceiling, certainly a near approach to daylight conditions would be obtained and no other system can equal it in this respect. The present cost of the vapor lamps in the long tubes that would be necessary in a mill renders it out of the question to use them in a large room, such as a spinning room, where special illumination is necessary.

Practical conditions in the mill, however, make it necessary, as a rule, to leave the ceiling as a light reflector out of consideration, on account of its con-

struction and the obstruction by shafting, pulleys, pipes, etc.; still, in every case, it will pay to bear in mind that the ceiling can be made a powerful aid to the light source by treating it so that it will reflect light instead of absorbing it.



FIG. 2.

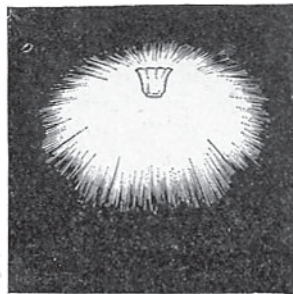

FIG. 3.

Light Waste. The most practical way to prevent waste of light, therefore, is to treat the light source itself. Every lamp should be fitted with some form of reflector to utilize the rays of light that would otherwise be wasted by going upwards or sideways, the shape and material of this reflector being carefully considered so as to get the best results. The nearer we approach natural condition, the better illumination we get; the best light is diffused light, direct light being too powerful for our vision, and if we diffuse our light instead of reflecting it downward in direct rays, we will secure the effect and qualities of daylight.

Perhaps the most scientific and effective device for utilizing the upward and horizontal light rays from

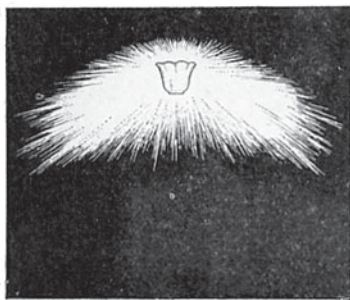

FIG. 4.

an artificial source is the Holophane glass globe or shade. These globes and shades are made of clear glass, their surfaces being cut into prisms of various angles and directions, either globe or shade being used according to conditions. The effect of a Holophane globe or reflector is that the upward and horizontal rays of light are refracted by the numerous prisms and are bent downwards and diffused over the space under the lamp; not only is the area underneath more brightly illuminated than by a naked light, but the general illumination is also increased. By the use of Holophane reflectors, the effective light of an arc or cluster of incandescent lamps is practically doubled, but little of the light being wasted upwards or sideways, and their employment cannot be too highly recommended. Where a single lamp is used, as for instance, several 32 c. p. incandescents located sep-

arately in the ceiling at short intervals apart, the Holophane hemispherical globe is recommended. Holophane reflectors, etc., are made and sold by the Holophane Co., New York, and the difference between their cost and the cost of the ordinary tin or glass reflectors is more than made up for by their greater lighting effect. Holophane globes and shades must be kept clean and free from dust to get their best efficiency.

Holophane Globes and Reflectors. In general, Holophane globes are made to throw a maximum light in one of three directions, downward, at an angle, and nearly horizontal. They are known as *Class A*, *Class B* and *Class C* globes. *Class A* globe, which throws the maximum light directly downward, and its effect on light is shown in Figure 2. *Class B* globe, which throws the maximum light at an angle of 45°, and its effect on light, is shown in Figure 3. *Class C* globe, which throws the maximum illumination at an angle of from 10° to 15° below the horizontal, and

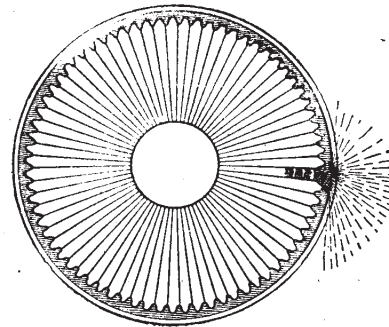

FIG. 5.

its effect on light, is shown in Figure 4. *Class A* would be used where the light is wanted in one place, as for a desk, over a loom, etc. *Class B* would be used for general illumination, as for the spinning room. *Class C* is designed for lighting large areas, where concentration of light is not desired.

The general construction of the Holophane globe is shown in Figures 5, 6 and 7. Fig. 5 gives a cross-section of a globe, showing by the broken lines on the right how the internal prisms break up and diffuse the light rays from the source of illumination inside. Fig. 6 is an enlarged view of the internal prisms of this globe, whose function it is to diffuse the light. Fig. 7 is an enlarged view of the external prisms,

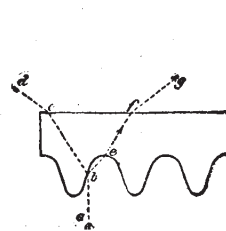

FIG. 6.

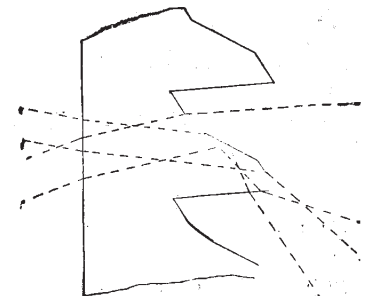

FIG. 7.

showing both refracting and reflecting surfaces. The dotted lines in these figures illustrate how the light rays are refracted, reflected and diffused. The prisms

illustrated are cut into the interior and exterior surfaces of the globes and are so arranged as to diffuse the light from the lamp inside in one of several desired directions, as shown in Figs. 2, 3 and 4.



FIG. 8.

Figure 8 shows a Holophane shade or reflector, in position over an incandescent lamp. This type throws most of the light downward, but over a large field, as shown in Fig. 9, which is a "light chart," showing the range of the light from the shade. This shade is best used for lamps that are to give a general illumination.

Figure 10 is another type of Holophane shade, or reflector, made with a deeper curve, so that it throws the light downward in a more restricted area than the former type, as is shown in Fig. 11, which is a "light chart," showing the distribution of light over a vertical plane. This reflector is most suitable for use where the light is to be directed downward for some distance and concentrated over a small area, as, for instance, a desk or a machine.

Reflectors, Etc. Ground glass or porcelain globes have long been used for the purpose of diffusing the light from a very bright lamp and for obviating the hurtful effect of its glare on the eyes. While these objects are secured in a measure, they are only obtained with a great waste of light, for all the way from 20% to 75% of the light rays emitted by the lamp are cut off by the opacity of the globe and are lost. As a matter of economy, it is thus certainly not

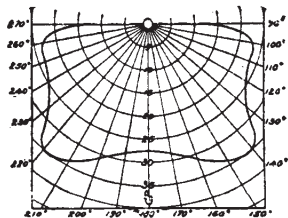

FIG. 9.

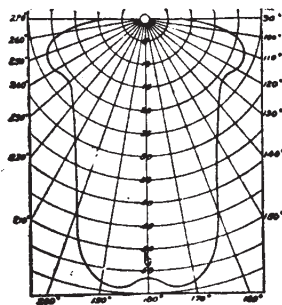

FIG. 11.

advisable to use any device that will so greatly lessen the efficiency of the lamps; the only time when such globes may be used is when nothing else is available for softening and diffusing the light from a brilliant lamp. When plain porcelain or tin reflectors are used over arc lamps, it is advisable to have the lower half of the globe made of ground glass to prevent the

downward glare, not much light being lost by its use here because the greater part of it is made useful by downward reflection. The "streaky" character of the light cast by a tin or porcelain reflector, however makes its use very trying to the eye.

Incandescent lamps, as usually fixed in their supports with the bulb vertical, give off the greater part of their light sideways. Hence, to obtain the maximum lighting effect, the globes should be fixed so that they are horizontal, or nearly so, the angle depending on the type of reflector used. If the Holophane globe or reflector is used, the lamp should be set in it so that the incandescent filament is enclosed, in order that the maximum portion of light will reach the prisms for diffusion.

Where machines are in long rows, the lamps, of whatever style, should preferably be placed over the machines rather than over the alleyways, unless high up and fitted with diffusing shades or reflectors. If



FIG. 10.

lamps are over alleys between machines, the operatives there will be apt to cause shadows to fall on the working parts when they stand between the lamp and the front of the machine.

(To be continued.)

THE ELECTRIC DRIVE FOR TEXTILE MILLS.

(Continued from page 175.)

The distribution and utilization of power by means of the electric drive (electric motors) offers many advantages when applied to textile machinery as compared with other systems of power transmission. These advantages may be briefly summarized as follows:—

1. Independent location of the power plant. Both the power plant and the mill may be located so as to obtain the maximum advantages of the site and the source of power; the mill does not necessarily have to be close to the power plant, which may be at a great distance from it.

2. It is possible to select exactly the right power unit or units for the most economical operation of the mill and the type of motor that will be best suited to the requirements of both the machine and the material used.

3. The ease with which additional power units can be installed for the mill itself or for extensions to it. Each additional unit will work in unison with those already installed and any one of them can be used to

(Continued on page viii.)

LIST OF ADVERTISERS

Altemus, Jacob K., Philadelphia.....	VII
American Dyewood Co., New York.....	XIII
American Textile Specialty Machinery Co., Providence, R. I.....	XVI
Berge, J. & H., New York.....	XI
Campion, Richard, Philadelphia.....	XI
Chapin, Geo. W., Philadelphia.....	IX
Cheney Brothers, South Manchester, Conn.....	V
Crompton & Knowles Loom Works, Worcester, Mass.....	Outside back cover
Draper Company, Hopedale, Mass.....	Inside front cover
Farbenfabriken of Elberfeld Co., New York.....	XVI
Firth & Foster Co., Philadelphia.....	IX
Grosser Knitting Machine Co., New York.....	VII
Halton's, Thomas, Sons, Philadelphia.....	III
Howard Brothers Mfg. Co., Worcester, Mass.....	IX
Hunter, James, Machine Co., North Adams, Mass.....	V
Jones, Frederick & Co., Philadelphia.....	XI
Kilburn, Lincoln & Co., Fall River, Mass.....	XV
Kip-Armstrong Company, Pawtucket, R. I.....	XI
Lentz, F. G., & Co., Philadelphia.....	XI
Littauer, Ludwig, New York.....	IX
Mason Machine Works, Taunton, Mass.....	IV
Metallic Drawing Roll Co., Indian Orchard, Mass.....	III
Oliver Typewriter Co., Chicago.....	XIII
Parks & Woolson Machine Co., Springfield, Vermont.....	-
Philadelphia Drying Machinery Co., The, Philadelphia.....	XVI
Queensbury Mills, Worcester, Mass.....	IX
Roessler & Hasslacher Chemical Co., New York.....	XV
Royle, John, & Sons, Paterson, N. J.....	III
Ryle, William, & Co., New York.....	IX
Schaellibaum, Rob., Co., The, Providence, R. I.....	XI
Sipp Electric & Machine Co., Paterson, N. J.....	XIII
Strouse, Theodore & Co., Philadelphia.....	XIV
Weimar Bros., Philadelphia.....	XIII
West Indies Chemical Works, The, New York.....	IX
Whitin Machine Works, The, Whitinsville, Mass.....	II
Wright, Robert A., Philadelphia.....	XV

BUYERS' INDEX

Apparatus for the Dye Trade.

Berge, J. & H.

Automatic Feeds for Cotton and Wool Stock.

Philadelphia Drying Machinery Co.

Belting.

Main Belting Co.

Bleachers.

Firth & Foster Co.

Bleaching Kiers.

Philadelphia Drying Machinery Co.

Bleaching Materials.

Roessler & Hasslacher Chemical Co.

Bobblins.

Draper Co.

Carbonizing Machinery.

Hunter, James, Machine Co.

Philadelphia Drying Machinery Co.

Card Clothing.

Howard Bros. Mfg. Co.

Card Stampers.

Lentz, F. G. & Co.

Carpet Machinery.

Altemus, Jacob K.

Philadelphia Drying Machinery Co.

Chemicals.

Berge, J. & H.

Roessler & Hasslacher Chemical Co.

West Indies Chemical Works, Ltd.

Chroming Machinery.

Philadelphia Drying Machinery Co.

Cost and Accounting Systems.

Wright, R. A.

Cotton Combers.

Mason Machine Works.

Whitin Machine Works.

Cotton Machinery.

Altemus, Jacob K.

Crompton & Knowles Loom Works.

Draper Co.

Halton's, Thomas, Sons.

Kip-Armstrong Co.

Mason Machine Works.

Metallic Drawing Roll Co., The.

Parks & Woolson Machine Co.

Philadelphia Drying Machinery Co.

Schaellibaum, Rob., Co., The.

Whitin Machine Works.

Cotton Yarns.

Chapin, George W.

Littauer, Ludwig.

Strouse, Theodore & Co.

Designers.

Lentz, F. G. & Co.

Drawing Frames.

Mason Machine Works.

Whitin Machine Works.

Drying Machinery.

Hunter, James, Machine Co.

Philadelphia Drying Machinery Co.

Dust Collectors.

Philadelphia Drying Machinery Co.

Dyers & Finishers.

Firth & Foster Co.

Dyeing, Drying, Bleaching and Finishing Machinery.

Hunter, James, Machine Co.

Parks & Woolson Machine Co.

Philadelphia Drying Machinery Co.

Dye Sticks.

Philadelphia Drying Machinery Co.

Dyestuffs.

American Dyewood Co.

Farbenfabriken of Elberfeld Co.

Dynamos & Motors.

Sipp Electric & Machine Co.

Electric Fans.

Philadelphia Drying Machinery Co.

Grids for Lappers.

Schaellibaum, Rob., Co., The.

Harness Builders.

Crompton & Knowles Loom Works.

Halton's, Thomas, Sons.

Lentz, F. G. & Co.

Harness Twine.

Littauer, Ludwig.

Heating and Ventilating Apparatus.

Philadelphia Drying Machinery Co.

Heddles.

Howard Brothers Mfg. Co.

Hematine.

West Indies Chemical Works, Ltd.

Jacquards.

Crompton & Knowles Loom Works.
Halton's, Thomas, Sons.

Jacquard Card Stamping, Lacing and Repeating Machinery.

Royle, John & Sons.

Knitting Machinery.

Grosser Knitting Machine Co.

Logwood Crystals.

American Dyewood Co.

West Indies Chemical Works, Ltd.

Logwood Extracts.

American Dyewood Co.

West Indies Chemical Works, Ltd.

Looms.

Crompton & Knowles Loom Works.

Draper Co.

Kilburn, Lincoln & Co.

Mason Machine Works.

Whitin Machine Works.

Measuring Devices.

Draper Co.

Parks & Woolson Machine Co.

Sipp Electric & Machine Co.

Metallic Rolls.

Metallic Drawing Roll Co., The.

Mohair.

Littauer, Ludwig.

Queensbury Mills.

Mules.

Mason Machine Works.

Office Supplies.

Oliver Typewriter Co.

Peroxide of Sodium.

Roessler & Hasslacher Chemical Co.

Pneumatic Conveyors.

Philadelphia Drying Machinery Co.

THE
**Grosser
 Knitting
 Machine
 Company**

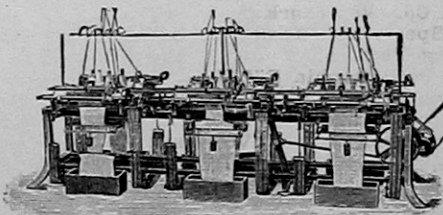

MAX NYDEGGER
 260 West Broadway, -- NEW YORK

Exclusive Agent
 for the Best
 Foreign Machine
 Manufacturers

REPRESENTING

C. F. GROSSER, Markersdorf, Bez. Leipzig: Manufacturer of all kinds of flat *Latch Needle Knitting Machines*, Lamb style, to be operated by hand or automatically run by power. *Best machines for manufacturing Jackets, Coats, Sweaters, Underwear, Fancy Knit Goods* in all styles, *Gloves, Stockings, Shaker Goods, Sporting articles, Jerseys, etc.* Spoolers and Winders especially adapted for Hosiery and Knit Goods Factories.

G. HILSCHER, Chemnitz: Manufacturer of "Cotton Hilscher" Machines for *fine gauge full fashioned Hosiery, Jerseys and Underwear*, Rip Top Frames "Cotton and Hilscher" style.

WILH. BARFUSS, Apolda: Manufacturer of WARP KNITTING machinery, double Rib Frames, etc., for all the *fancy articles, Shawls, Hoods, Caps, Fascinators, etc.* *Glove fabric* in Silk, Cotton and Worsted, *Lace Gloves, etc.*

C. TERROT SOEHNE, Cannstatt - Stuttgart: Manufacturer of French Circular Frames, producing *finest Balbriggan for Underwear, Fancy stitches, Lace work "Poros Knit."* Machines for using Hard Worsted or Lisle, Yarns, Silk, etc.

JULIUS KOEHLER, Limbach: Manufacturer of the "DIAMOND" *Overseamer* for all selvaged articles as Full Fashioned Hosiery, Underwear and other knit articles. **LOOPERS**, producing finest elastic and flat seam. If you make Hosiery or Underwear *YOU cannot be without it.*

BEST GERMAN LATCH BEARD NEEDLES. *Quality is the money saver.* If you want anything in Knitting Machines, etc., write to me. My long experience in the Knitting line is yours for the asking. Information and samples supplied upon application.

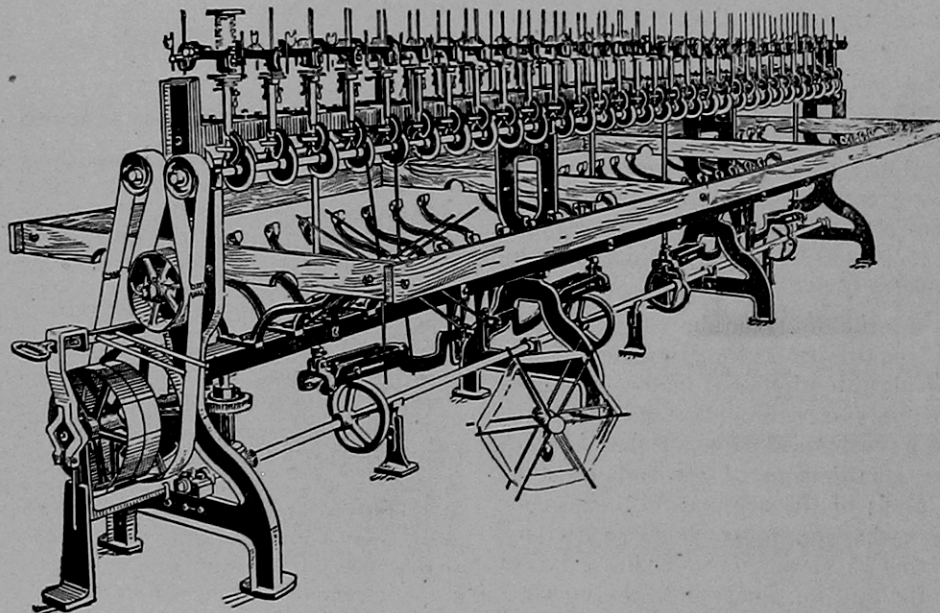

UPRIGHT SPINDLE SPOOLER

Friction Drive, Knock off for Spools.

Wire Swifts used for Fine Yarns,

Pin Swifts on Hard Twisted Yarns.

JACOB K. ALTEMUS, 2824 N. Fourth St., Philadelphia, Pa.

BUYERS' INDEX—Continued**Power Transmitting Machinery.**

Philadelphia Drying Machinery Co.

Presses.

Philadelphia Drying Machinery Co.

Printing Drums.

Crompton & Knowles Loom Works.

Pumps.

Philadelphia Drying Machinery Co.

Quillers.

Sipp Electric & Machine Co.

Whitin Machine Works.

Railway Heads.

Mason Machine Works.

Whitin Machine Works.

Reels.

Draper Co.

Sipp Electric & Machine Co.

Whitin Machine Works.

Revolving Flat Cards.

Mason Machine Works.

Whitin Machine Works.

**Ribbons and Piece Silks for Trimming
Knit Goods.**

Cheney Bros.

Shuttles.

American Textile Specialty M'ch'y Co.

Silk Machinery.

Altemus, Jacob K.

Crompton & Knowles Loom Works.

Halton's, Thomas, Sons.

Mason Machine Works.

Sipp Electric & Machine Co.

Silk Yarns.

Cheney Bros.

Littauer, Ludwig.

Ryle, William, & Co.

Spindles.

Draper Co.

Spinning Frames.

Mason Machine Works.

Whitin Machine Works.

Spinning Rings.

Draper Co.

Spoolers.

Draper Co.

Whitin Machine Works.

Tanks and Tubs.

Philadelphia Drying Machinery Co.

Tapes, Braids and Edgings.

Chapin, George W.

Weimar Brothers.

Temples.

Crompton & Knowles Loom Works.

Draper Co.

Textile Design Papers.

Jones, Frederick, & Co.

Threads.

Chapin, George W.

Littauer, Ludwig.

Tinsel.

Littauer, Ludwig.

Twisters.

Draper Co.

Mason Machine Works.

Whitin Machine Works.

Warp Stop Motions.

Crompton & Knowles Loom Works.

Draper Co.

Kip-Armstrong Co.

**Winding, Beaming and Warping Ma-
chinery.**

Altemus, Jacob K.

Draper Co.

Whitin Machine Works.

Wool Combers.

Crompton & Knowles Loom Works.

Woolen Machinery.

Altemus, Jacob K.

Crompton & Knowles Loom Works.

Hunter, James, Machine Co.

Philadelphia Drying Machinery Co.

Woolen Yarns.

Littauer, Ludwig.

Queensbury Mills.

Wool Washing Machinery.

Hunter, James, Machine Co.

Philadelphia Drying Machinery Co.

Worsted Yarns.

Campion, Richard.

Littauer, Ludwig.

Queensbury Mills.

Yarn Testing Machinery.

Sipp Electric & Machine Co.

(Continued from page 216.)

transmit power to any section or all sections of the mill, as may be desired.

4. The enlargement of the mill is made independent of its power plant or of the relative position of its main drive. New buildings can be put up anywhere to suit the topography of the building site or to obtain better conditions of light and ventilation, either near the old mill or at a distance from it. The power can readily be distributed to any section or to any building by means of wires, which can be easily, cheaply and quickly installed and which do not have to follow any predetermined arrangement or plan and which can be placed underground or strung overhead for great distances. There is a great saving in space by the omission of belt towers, shafting, etc., and in the cost of heavy shafts and long belts or ropes, also in the compactness of the electric drive.

5. Extensions of the mill can be made without reference to the requirements for increased power other than to provide the additional motors and generators that will be necessary to operate the additional machinery. With a mechanical drive, all details relating to the future enlargement of the mill must be made before the plans of the original mill are made, the engines, boilers, shafting, power house, etc., must be planned with this in view. This means a larger additional cost to the mill for power until the enlargement is made, and until it is made, this is a dead loss.

6. Motors can be located at the most convenient place for driving a section of machines, a room or a floor. This effects a great saving in the cost of installation, as it cuts down the shafting and belting and reduces to a minimum the number of belts between a motor and the driving head of the machine. Both the amount and the weight of shafting is much less and there is a consequent saving in frictional losses.

Lighter belts can be used, this also effecting a saving in frictional losses and in the wear on the belts themselves. When several belts are used, as is necessary with the old mechanical drive, there is a great loss of power because of the slipping of the belts and friction on the pulleys, and every belt used means so much slippage and friction and a consequent loss of speed and power. This loss in a mechanical drive may amount to 30%, or more.

*(To be continued.)***Questions and Answers.**

QUESTION: "I wish to get the following information from you. Please tell me what a piece of dress goods, 8 harness Dobby weave, made on the following construction should weigh, allowing 10% increased weight for sizing:

1800 ends, 32 ends selvage, making a total of 1832 ends in the warp.

29 dent Reed.

2 in dent (space in reed about $31\frac{1}{2}''$).

58 picks in filling.

All yarn, both filling and warp, single 22's cotton.

I would thank you to send me your figures in order that I may see just how you figure this proposition, as there are so many ways of figuring this problem and most of them are so inaccurate. We find that there is a great disparity between what we calculate the goods should weigh and what they actually weigh when woven, and what I am trying to get at is your method of figuring the weight of goods when the construction is given and how you allow for take-up, etc."—R. S. M.

ANSWER: Regarding your question come to say, you have not stated what weave you used and which to a certain extent regulates take-up of the warp at weaving, hence weight of cloth. If you had sent a sample of the fabric, it might have guided me in said take-up during weaving, still it is a minor affair. Some mills use regularly 10% for said take-up, which, however, is not accurate, since it depends upon the weave

(Continued on page xii.)

**GEORGE W. CHAPIN
COTTON YARNS**

TAPES, BRAIDS, THREADS
LACE EDGINGS

229 CHURCH STREET 231
PHILADELPHIA, PA.

N. Y. Office, 350 Broadway

R. E. SCHNEEBELI, Res. Manager

LUDWIG LITTAUER

Successor to Moeller & Littauer

**Y
A
R
N
S**

Thrown Silk
Artificial, Shappe and Spun Silk
Domestic and Imported, Plain
Gassed, Mercerized and Polished Cotton
Polished and Glazed Threads
Mohair and Worsted
Tinsel
Turkey Red

**Y
A
R
N
S**

109 GREENE ST., NEW YORK

Best Quality Harness Twine

The West Indies Chemical Works, Limited
Manufacturing Only the One Product

**PURE LOGWOOD
EXTRACTS**

WE ARE ABLE TO GIVE YOU THE BEST
WORKS—JAMAICA, WEST INDIES
(where the Logwood Grows)

NEW YORK OFFICE, 26 CLIFF ST.

WILLIAM RYLE & CO.

Foreign and Domestic

Spun Silk Yarns and Noils

Domestic Thrown Silk of every de-
scription. Fine Pure Dye Silks for
the woolen trade a specialty. Import-
ers of European and Asiatic Raw Silk

54 Howard St. NEW YORK

**FIRTH & FOSTER CO.
DYERS and FINISHERS**

OF PIECE GOODS EXCLUSIVELY

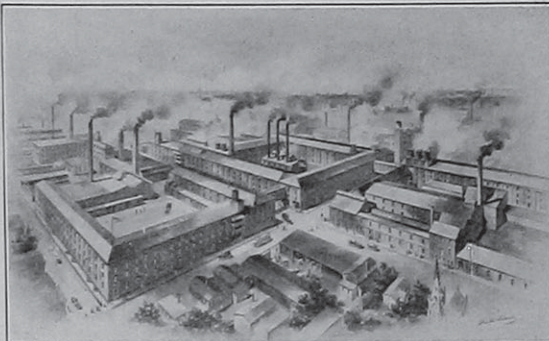

*The best equipped plant for the DYEING
and FINISHING of fine wool and wors-
ted goods, also silk and wool fabrics.*

EMERALD, YORK AND ADAMS STREETS

PHILADELPHIA

NEW YORK OFFICE: Silk Exchange Bldg., Room 702

QUEENSBURY MILLS

H. HODGSON, Pres. and Treas. FRED. HODGSON, Gen. Mgr.

MOHAIR

FLYER
SPUN
YARNS

*Mohair Tops
and
Yarns for Weaving
Single and 2-ply*

ALPACA
AND
WORSTED
YARNS

WORCESTER, MASS.

ESTABLISHED 1866
INCORPORATED 1888

A. H. HOWARD, PRES. AND MGR.
HERBERT MIDGLEY, SECT.

HOWARD BROTHERS MFG. CO.

MANUFACTURERS OF

CARD CLOTHING

Hand Stripping Cards, German and Domestic
Heddles for Cotton and Woolen Mills
Revolving Top Flats Remounted
Fillets Redrawn

PHONE 1070. LOCAL AND LONG DISTANCE

44 and 46 Vine Street, Worcester, Mass.

QUALITY SELLS OUR GOODS

NOVELTIES IN DESIGNS.

We herewith show the reader four new designs.

A is a new, original, and ornamental design for neckwear fabrics, just patented by Mr. L. Auerbach.

B is a new, original and ornamental design for a lace curtain, just patented by Mr. Wm. Hardy.

C and *D* are new, original and ornamental designs for woven fabrics, just patented by Mr. C. H. Landenberger.

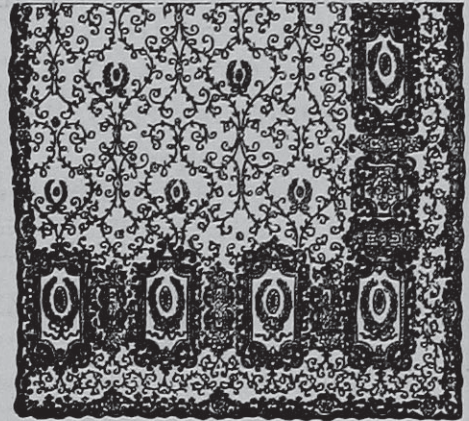
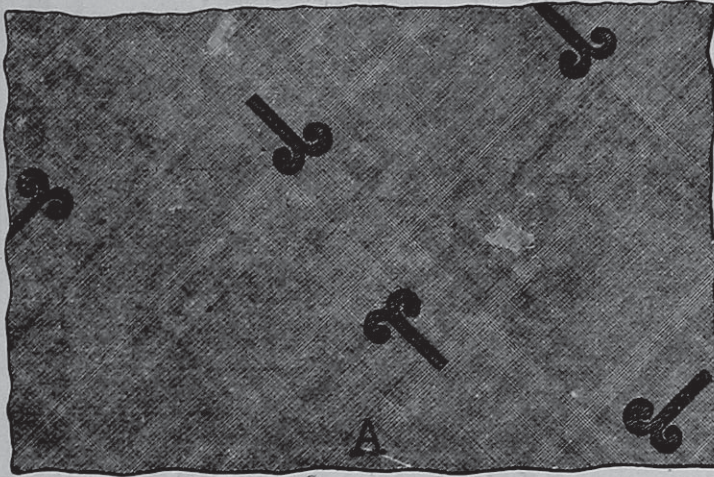

B

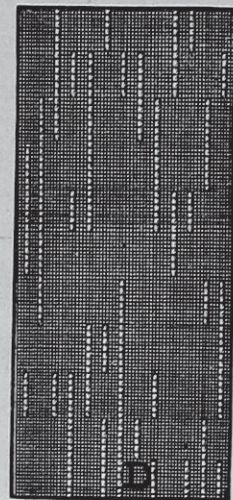
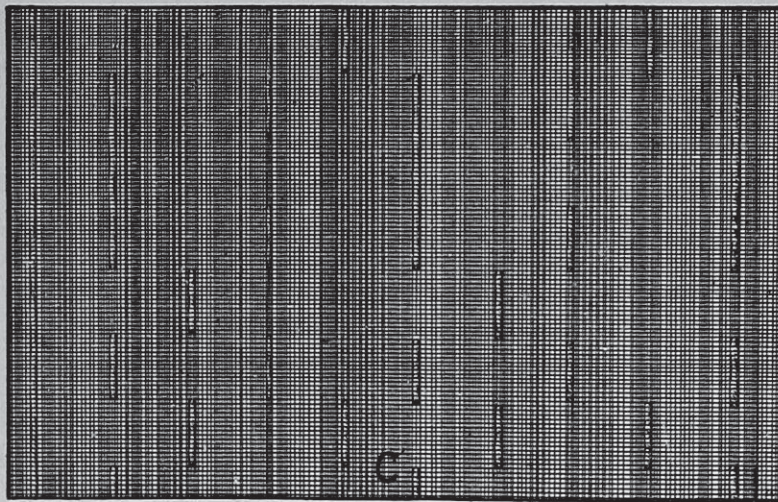

D

Gleanings from the Bureau of Statistics.

Notwithstanding the fact that the United States produces three-fourths of the world's cotton, has a greater number of spindles than any other country except the United Kingdom, has over \$600,000,000 invested in its cotton manufacturing establishments, and turns out products valued at \$500,000,000 per annum (including cotton knit goods), the value of cotton manufactures imported is steadily increasing, and was in the fiscal year 1907 twice as great as in 1897, over two and one-half times as great as in 1887, and nearly four times as great as in 1877.

The rapid increase in the imports of cotton manufactures into the United States occurs chiefly in the high-grade goods, and especially in those in the production of which hand labor forms an important part. In this connection the following figures show the imports of the several classes for the nine months ended

September 30, 1907: Laces, edgings, embroideries, insertings, ruchings, lace window curtains, etc., \$30,629,368; cotton cloth—bleached, dyed, colored, printed, etc., \$9,864,106; knit goods, \$7,247,567; plushes, velvets, and velveteens, thread, yarn, etc., \$11,796,601; total, \$58,796,601. The first group (laces, etc.) shows the largest increase, amounting in round numbers to \$10,000,000, as compared with the same months in 1905, while for the same period all other classes combined show an increase of \$9,000,000. The imports of the first group now average \$40,000,000 annually, and for the first nine months of 1907 the shares furnished by the various countries were as follows: Switzerland, \$10,742,408; France, \$9,467,887; United Kingdom, \$5,401,858; Germany, \$4,205,558; other countries, \$811,657; total imports for the nine months, \$30,629,368.

WORSTED YARNS
RICHARD CAMPION
 Selling Agent for
 BRISTOL WORSTED MILLS
 HIGHLAND WORSTED MILLS
 THE FRENCH WORSTED CO.
 300 Chestnut Street PHILADELPHIA

CHEMICALS AND APPARATUS
FOR THE DYE TRADE
J. & H. BERGE
 Best Bohemian Chemical Glassware and German Porcelain.
 C. P. Chemicals and Reagents, Chemists' Supplies of all kinds.
 95 JOHN STREET, NEW YORK

FREDERICK JONES & CO.
 58 North 4th St., Phila.
TEXTILE DESIGN PAPERS
 FOR ALL FABRICS

National Prosperity
TEXTILE MANUFACTURES
 (From Latest Census Reports)

Value wool manufactures, twelve months . . .	\$381,000,000
Value cotton goods	450,000,000
Value hosiery and knit goods	137,000,000
Value silk manufactures	133,000,000
Value Flax, hemp and jute manufactures	63,000,000
Dyeing and Finishing textiles	51,000,000
Total value textile manufactures	\$1,215,000,000

PATENT GRID WITH COMB
 For Cotton Openers and Lappers
*We are prepared to sell other specialties
 for cotton mills in all Textile countries*
The ROB. SCHAELLIBAUM CO.
 288 Dyer Street, Providence, R. I.



F. G. LENTZ & CO.
**Designers, Card Stampers
 and Harness Builders**
 FOR ALL TEXTILE FABRICS
 Mascher, Waterloo and York Sts.
 Both Phones PHILADELPHIA, PA.

SIMPLICITY

THE K-A IDEA

**KIP-ARMSTRONG
 COMPANY**

*Manufacturers of the
 K-A Electrical
 Warp Stop-Motion
 and other*

TEXTILE ECONOMY DEVICES

*New INVENTIONS in
 Mechanical Textile Devices
 Developed and Exploited.
 Correspondence Solicited.*

KIP-ARMSTRONG CO.
 Pawtucket, R.I., U.S.A.

(Continued from page viii.)

used. You can readily get on said take-up, of the warp most accurately by taking into consideration yards dressed and yards woven from it.

Warp: Allowing for example, 10% take-up for warp during weaving will give you

$$1832 \times 10 = 18320$$

$$18320 \div 9 = 2035 \text{ yards of 22's cotton for warp, and}$$

$$2035 \times 16 = 32560$$

$$32560 \div 18480 = 1.76 \text{ oz.}$$

$$\text{Filling: } 58 \times 31.5 = 1827 \text{ and}$$

$$1827 \times 16 = 29232$$

$29232 \div 18480 = 1.58$ oz. and what will give you 3.34 oz. as total weight of yarn used, exclusive of sizing, and to which you can readily add the 10% additional weight on account of sizing as quoted in your letter.

Considering matters all around, I think the difference in weight of your fabrics has little to do with calculations on your part, it being caused by spinning uneven yarn, one day on the heavy side, next time on the light side, of 22 as to counts; or it may be the cause of uneven sizing. You will readily have to agree with me that it is impossible for any spinner to spin any count of cotton yarn accurate right along, in fact it is a question; whether he can spin it accurately down to the hundredths or thousandth part of an ounce in the fabric, any time, and it is this variation which will make the trouble. The best plan to get over this trouble is to have your yarn frequently reeled and try your best to keep an even count. One of the troubles which might come up occasionally, say for example, is your filling running on the heavy side, your boss weaver might possibly take out one or two picks and at the same time when he takes out these one or two picks, the yarn might be on the light side, and which naturally will upset the whole affair; the best plan to do, as stated before, is always to be after your spinner and have him reel the yarn frequently, have him reel it once more a day than he does and what might be better, at random, have it reeled by one man in your office off and on and in this way find out for yourself what kind of yarn he is spinning for you during the week, and I would not be astonished if some time you would find out that he is spinning 24's or 26's in place of 22's. That is where your main trouble rests, still at the same time, look after the amount of sizing, since this may vary on different days. Men in a mill always get careless except they know somebody is after them with a yard stick and the scale. I know from my own experience that in one mill we had one man from the office do nothing else all day, but reel yarn, in order to keep the spinner on the lookout for trouble. However, we then were in need of an exact count, on account of the high grade of yarn spun. I am convinced that if you look after your spinner you will get over the trouble, since to my estimation he is at the bottom of it.

QUESTION: "We make light-weight cloths from the following mixture: Cotton 65%, Pulled Wool 25%, Shoddy 10%; these are scoured before fulling, fulling thirty minutes, then washed off in the same manner as cloakings, but have always a greasy smell. We have tried fulling some dry, same as cloakings, but the smell remains. The soap we use is made from the following formula: Red Oil 550 lbs., Tallow 200 lbs., Caustic Potash 200 lbs., Water 800 gallons. In fulling, we use one gallon of this soap to three gallons of water.

(1) Is the trouble caused by the soap and is it a good formula?

(2) Does the 25% pulled wool have any effect on the soap? The wool is chromed and dyed before using, the cotton is all used in the white."—T. D.

ANSWER: (1) *Soap.* The quality, etc., of the soap made from formulas similar to the one submitted depend greatly on the skill and care of the person who is entrusted with the work, and on the method of making it; as, unless the soap is carefully made it will contain uncombined oleic acid and caustic potash. As the soap will be of a soft consistency, unless it has been boiled down, it will not be so easy to detect the imperfect combination as it would be in a hard soap made with caustic soda, hence the soap should be tested before it is used. The formula given seems to call for too much caustic potash if that used is of full strength, which in the best commercial grades should average about 90%. Theoretically, red oil (which is crude oleic acid) requires about 20% of its weight of caustic potash for exact saponification and tallow requires from 19.5% to 19.8% of its weight of caustic potash, *chemically pure*, therefore, 550 pounds of red oil would require 110 pounds of pure caustic potash, and 200 pounds of tallow would require about 40 pounds, or a total of 150 pounds. However, as commercial caustic potash is never full strength, more of it will be necessary than the theoretical quantities just given, the exact amount being calculated, according to the proportions stated, when the strength of the caustic potash used is found by chemical tests. For example, if 90% caustic potash is to be used, instead of 150 pounds, 167 pounds will be required, for exact saponification. It must be borne in mind, however, that more than the exact theoretical quantity of caustic potash will be necessary to insure making a good soap.

A slight excess of alkali is not objectionable in a potash soap to be used for fulling woolen or mixed goods, since the excess insures complete removal of the grease in the cloth. A potash soap is much better than a soda soap for fulling or scouring wool or woolen goods, as caustic potash and potash soaps do not act so severely on the wool fibre as does caustic soda, and they do not leave the goods feeling harsh. Potash is naturally present in wool in the form of potassium oleate, etc., hence its action on wool fibres is less apt to damage them.

The soap referred to, even if properly made, can cause an odor in cloth fulled with it, if the water used is "hard," *i. e.*, contains lime. This will depend a good deal upon the purity of the red oil and tallow used for making the soap, since if these have a strong smell themselves, it will be given to the cloth when the hard water causes a precipitation of lime soaps on the fabric. If the water used contains lime, it will decompose the potash soap and form insoluble lime soaps on the fibres of the cloth, which cannot be removed by ordinary rinsing, in fact, rinsing with hard water will increase the trouble. The remedy would be to use a supply of soft water or else treat the present water supply to soften it and use it after it is softened and filtered or is allowed to settle. Lime, in any form, that may get into the fulling mill and be mixed with soap will cause trouble.

(2) *Pulled Wool.* The smell in the finished cloth may be due to the pulled wool, from two different causes, provided the water is soft and that the trouble does not come from this source.

First, the smell may come from the wool itself. Pulled wool is taken from sheepskins previous to tanning them, and, if the skins have acquired a bad smell from decaying animal matter, the wool-fat, etc., will absorb this smell and retain it very persistently. The remedy would be a thorough scouring of the wool until all grease, etc., are removed, before it is used or treated. If the wool is chromed before it has been thoroughly washed, the chroming will be apt to "set" the remaining grease and thus make it harder to wash it out and remove the bad smell.

Second, the greasy smell in the cloth may be due to de-

(Continued on page xv.)

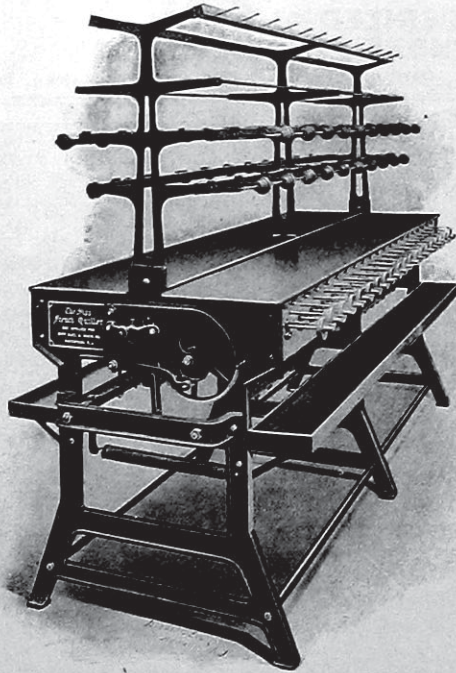

The Sipp Improved French Quiller

The QUILLER that Will Produce More

GOOD QUILLS IN LESS TIME

Than Any Other QUILLER Made

Prices and Circulars on Application to

THE
Sipp Electric and Machine
Company

Keen and Warren Streets and Erie R. R.
PATERSON, N. J.

The OLIVER Typewriter

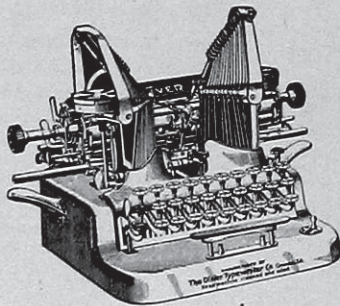

The Standard Visible Writer

Universal Keyboard. The winner of awards everywhere. Art Catalogue free—Ask for it

The Oliver Typewriter Co.
WALNUT AND TENTH STS., PHILADELPHIA, PA.

WEIMAR BROTHERS
MANUFACTURERS OF
Tapes, Bindings and Narrow Fabrics
2046-48 AMBER STREET
PHILADELPHIA

American Dyewood Company

Haematines for Wool
Logwood Crystals
Logwood Extracts for Cotton
Fustic Extracts
Aniline Colors
Indigo

AMERICAN MADE GOODS
for
AMERICAN CONSUMERS

New York Philadelphia Boston

THEODORE H. STROUSE & CO. 426-428 MARKET STREET,
PHILADELPHIA, PA.
COTTON YARNS, MERCERIZED AND PLAIN.
FINE SINGLE, TWO AND THREE PLY UP TO 200's.
Sole American Agents for Messrs. Wm. A. Holt, Ltd., Cotton Spinners and Doublers, Bolton, England.

Superintendent or Assistant Superintendent and Designer. 22 years experience on Woolen and Worsteds, here, Canada and in Scotland. Holds certificates from The City and Guild of London, and the Galashiels Manufacturers Corporation (1902). R. L. 10, POSSELT'S TEXTILE JOURNAL.

Superintendent for Knitting Mill in Georgia. To take charge of 100 Latch needle machines on Women's and Children's Ribbed Underwear (Cotton). We require a man who can manage machines, material and help to best advantage. Address only with full particulars: C. K. Co. 12, POSSELT'S TEXTILE JOURNAL.

Boss Finisher. Have had thirty years experience as a textile finisher. Understand dry finishing of woolen goods, and all classes of cotton goods from loom to case. Also cotton bleaching, knit goods, piece goods, skeins and warps. Am a good manager of help, can manage any department in finishing or superintend cotton bleachery and finishing works. J. H. 11, POSSELT'S TEXTILE JOURNAL.

Boss Weaver with 6 years' experience in Philadelphia mills, would like position in New England, Rhode Island preferred. Best of references. L. S., POSSELT'S TEXTILE JOURNAL.

Boss Weaver, 10 years' experience in a prominent Maine Woolen Mill and 2 years in Philadelphia, wants position, no objection to go West. S. H., POSSELT'S TEXTILE JOURNAL.

Designer and Superintendent understanding warp dressing, weaving and finishing silk velvets, plush, mohair, cotton plush, pile fabrics and dress goods; Crompton and Knowles Looms. Age 32, married, willing to go anywhere. H. R. S., POSSELT'S TEXTILE JOURNAL.

Designer for Woolen and Worsteds, Graduate from Posselt's Textile School, with two years' practical experience in New England mills, is open for position either as designer or assistant to superintendent. H. B., POSSELT'S TEXTILE JOURNAL.

Boss Dyer, 3 years' experience as overseer on wool, yarn, piece-goods and mixes. Age 25, German, best of references. S. K., POSSELT'S TEXTILE JOURNAL.

For Sale. Scale (Troemner), agate bearings, dust-proof case, never been used, cost \$35; also a practically new Microscope (Zentmayer), cost \$75. Address: Student, care of JOURNAL.

MILL NEWS

Middle States

New York. The United Woolen By-Products Company, dealers in woolens and silks, with a capital of \$3,000,000, filed recently a certificate of incorporation with the Secretary of State.

Allentown, Pa. All departments of the Allentown Spinning Company, after a suspension of seven weeks, are again in operation. During this time new engines have been installed and other improvements made. The mill employs about 1,000 people.

Paterson, N. J. The United Ribbon Company expect to erect in the spring a \$60,000 building on the old Vreeland estate, between Keen and Franklin Streets.

Allentown, Pa. The Givernaud Silk Mill, at Washington and Meadow streets, is running full time with a full force of employes. Superintendent Frova informs us that the mill has plenty of work, mostly in the fancy grades of silk.

New England States

North Salem, N. H. The woolen mill of John W. Wheeler & Sons was destroyed by fire at a loss estimated at \$100,000, covered by insurance. The origin of the fire is unknown. The blaze started on the second floor of the four-story brick building.

Northampton, Mass. The mill of the McCallum Company, manufacturers of silk hosiery, which has been running on short time for about two months, has resumed the full time schedule. The mill employs 200 hands.

Clinton, Mass. The Bigelow Carpet Company are preparing to make several additions to their present plant, consisting of a new power house and system for heating and lighting, addition to their weaving departments, etc., also arranging for a siding from the Boston and Maine Railroad.

Lowell, Mass. The Lowell branch of the Bigelow Carpet Company are erect-

ing a new mill. The structure is to be 400 feet long, with a width of 100 feet, and will be five stories in height.

Providence, R. I. James R. Lister of the Centerdale Worsted Mills has purchased a suitable building and will engage in the manufacture of worsted yarns. The plant will be known as the Colored Worsted Mills. The company is incorporated for \$50,000.

Southern States

Statesville, N. C. The Long Island Cotton Mills declared their regular semi-annual dividend of 5 per cent at their annual meeting recently. The enlargement of the mill is now completed.

Concord, N. C. The Edgemere Manufacturing Company of Great Barrington, Mass., who operated a mill at this place have transferred their machinery to the Hanover Manufacturing Company on account of the lease on the buildings having expired. The latter mill now has a total of 4,000 spindles and 40 looms.

Kinston, N. C. The construction on the proposed plant to be erected for the Caswell Cotton Mills will be started about April 1. A two story structure, 200 by 80 feet is to be erected and which will have a capacity of 15,000 spindles. This concern was incorporated last October, with \$200,000 capital stock.

Kernersville, N. C. The Crews Manufacturing Company will remodel its present plant and erect an additional building. They will also install new machinery in order to largely increase the present output.

Kinston, N. C. The equipment of the Kinston Cotton Mills has been increased by 8,000 spindles, making a total of 20,000 spindles for producing hosiery yarns. It is estimated that about 350 operatives will be employed. The main building addition is 78 by 114 feet, two stories, and the picker room 45 by 75 feet.

Wake Forest, N. C. The addition to the plant of the Royall Cotton Mills has been completed at an estimated cost of about \$100,000. The structure is three stories high. The equipment consists of 4,992 ring and 2,240 twister spindles. The plant now has a total of 16,000 spindles, 5,000 twister spindles and 186 looms.

We are prepared to prove that Peroxide of Sodium for

Bleaching
animal & vegetable fibres
or their mixtures
is the best.
Roesler & Hasslach
Chemical Co.
New York



KILBURN, LINCOLN & COMPANY
LOOMS FOR
COTTON AND SILK WEAVING
FALL RIVER, MASS.

(Continued from page xii.)

composition of the soap used in fulling by lime in the pulled wool. The sheepskins from which pulled wool is obtained are often treated with lime to loosen the wool and make it easier to get it off. Unless the wool is first treated with an acid to remove the lime left in it, no ordinary washing will take it all out, and whenever this wool comes in contact with soap, the lime will decompose it. Consequently, if strong-smelling oils or fats have been used for making the soap, they will be deposited on the cloth during its fulling, in the form of lime soaps which cannot be washed out in the ordinary rinsing process following.

The fulling soap might also be decomposed by the acid or bichromate left in the pulled wool after chroming and dyeing if the wool had not been rinsed clear from acid before working it up into the cloth. A small amount of acid might be left in the wool and be unnoticed during the spinning and weaving, but would at once become apparent when the cloth was wet with the soap mixture, when it would decompose the potash soap and cause a deposit of fatty matter on the fibres of the cloth. This trouble, however, would hardly occur, unless the pulled wool was dyed in an acid liquor and imperfectly washed out afterwards, and allowed to dry.

A good plan to follow will always be to buy your soap from a reliable soap manufacturer in place of trusting your help to make it in the mill.

Cost and Accounting Systems
Periodical or Casual Audits

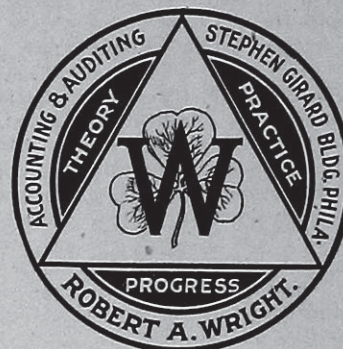

Consultations and
General Accounting



"HURRICANE" DRYERS

For Wool, Cotton Stock, Yarn, Knit Goods, Etc.

Belt-Driven **FANS** Motor-Driven

Power Screw **PRESSES** Hydraulic

WRITE FOR CATALOGUES

THE PHILADELPHIA DRYING MACHINERY CO.,
6721 GERMANTOWN AVE., PHILADELPHIA, PA.

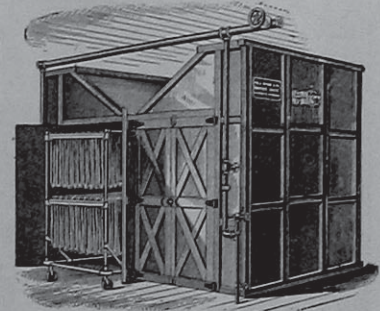

Boston. Providence. Philadelphia. Chicago. Charlotte. Albany. Toronto, Can.

FARBENFABRIKEN OF ELBERFELD CO.,

IMPORTERS OF ANILINE & ALIZARINE COLORS

P. O. Box 2162

NEW YORK

66 Lafayette Street

AMERICAN TEXTILE SPECIALTY MACHINERY CO.

MANUFACTURERS OF

Shuttles and Shuttle Irons for all Textile Purposes

NEVER-SLIP. COP SPINDLES AND TUBES

N. Y. Office, 363-373 Rider Ave.

670 Eddy St., PROVIDENCE, R. I

East Monbo, N. C. The plant under construction for the Turner Mills Company is progressing rapidly. Water-power will be used and about 350 horsepower will be developed. The machinery will consist of 7,616 spindles. The capital stock is \$250,000.

Charleston, S. C. The proposed mill for Charleston will be known as the Charleston Waste Mills, capital stock \$200,000. It is the intention to consume the waste of cotton mills throughout this State, which will amount to about 30,000,000 pounds annually to be manufactured into wadding, batting, blankets and rope.

North Augusta, S. C. It is reported that T. L. Foreman has completed arrangements for the establishment of the Dixie Knitting Mills, and a plant for the production of hosiery for ladies will be erected. About fifty dozen pairs will be the daily output.

Spartanburg, S. C. It is reported that the Crescent Manufacturing Company will equip a department for spinning cotton yarns for their own use.

Greenville, S. C. The additions to the Carolina Mills have been completed. Their equipment consists of 12,000 spindles and 356 looms. Their product of print cloths and medium weight goods it is claimed is sold up to July 1.

Oakwood, S. C. It is reported that C. E. Hallman will erect a knitting mill here with an equipment sufficient to turn out about 150 dozen pairs of half-hose.

It is his intention to have the mill in operation in the early summer.

Tallapoosa, Ga. The two-story brick building and warehouse for the Tallapoosa Mills have been completed. 10,000 spindles have been installed for the manufacture of 20's two-ply warps and skeins, to be increased at a future date. The capital stock is \$200,000.

Paducah, Ky. The Wisdom Hosiery Company have commenced operations, their daily output being 900 dozen pairs, giving employment to about 200 persons. There is a likelihood of them doubling their present plant of 150 knitting machines. They operate a complete dyeing and finishing plant, using the sulphur process in connection with the former.

Atlanta, Ga. The Atlanta Guarantee Hose Company contemplate the establishment of a knitting mill in this locality in the near future. About \$50,000 will be invested and bids on machinery will be wanted about March 1. The company's offices are at 34½ Peachtree Street, D. F. Ferriss, president.

Madisonville, Tenn. The Madisonville Knitting Mills, capital stock \$25,000 (\$15,000 paid in), it is rumored, has placed orders for 30 knitting-machines, e'c. Women's hosiery will be the output. Mr. T. L. Upton is the manager of the new concern.

Chattanooga, Tenn. It is rumored that plans have been completed by the Wachovia Mills for the erection of a large cotton mill with 100,000 spindles

and 3,500 looms for the manufacture of cloth. A finishing department will also be installed.

Madisonville, Tenn. The Madisonville Knitting Mills have been organized with a capital stock of \$15,000. It is their intention of installing sufficient equipment to enable them to turn out 250 dozen pairs of ladies' hosiery daily. Thomas L. Upton will be the general manager.

Knoxville, Tenn. The two-story addition to the Knoxville Cotton Mills has been completed. They have installed 28 spinning frames of 240 spindles each, 2 pickers, blowing system, 6 speeders, 2 intermediate and 12-forty inch cards.

Childersburg, Ala. The erection of the mill building of the Coosa River Spinning Company is progressing rapidly. It is to be a 10,000 spindle plant and will be in operation about March. F. S. Hinds of Boston is the architect for the mill structure.

Birmingham, Ala. The Avondale Mills of this city have recently installed several hundred looms to take the place of the old type looms that they had been using. The output of the mill is fine chambrays.

Dadeville, Ala. It is reported that Messrs. Hall Bros. propose to establish a small spinning and knitting plant, and are in the market for the necessary machinery.

“Textile Designing Simplified.”

The object of this chart is to show how easy weaves for all classes of Textile Fabrics can be constructed; it will be a search light in the misty matters in the field of designing Textile Fabrics. Keep this chart of weaves for reference. Millions of new weaves can be obtained by it.

All weaves for Textile Fabrics have their foundation in Plain Twills and Satins.

PLAIN.—This weave and its sub-divisions are explained on the chart in the top row by 16 weaves, the sub-divisions covering common, fancy and figured Rib and Basket weaves.

TWILLS.—The foundation of constructing regular (45°) twills is shown by rows 2 and 3 with twenty six weaves, covering twill weaves all the way from 3 harness up to 13 harness. The sub-divisions of twills are quoted next on the chart, being Broken twills, Skip twills, Corkscrews, Double twills, Drafting twills, Curved twills, Combination twills warp drafting, Combination twills filling drafting, 63° twills, 70° twills, Wide wale twills, Entwining twills, Checker-board twills, Pointed twills, Fancy twills, thus covering every sub-division of twill weaves possible to be made.

SATINS are next shown, giving also their sub-divisions, viz: Double satins and Granites.

HOW TO PUT A BACK FILLING ON SINGLE CLOTH is shown below the satins by two examples, and at its right hand is quoted the principle of

HOW TO PUT A BACK WARP ON SINGLE CLOTH.

On the bottom line are given the four steps for:—
THE CONSTRUCTION OF DOUBLE CLOTH, 2 @ 1; and above the same one example, with the arrangement 1 @ 1.

THREE PLY CLOTH is shown by one example.

HOW TO BACK SINGLE CLOTH WITH ITS OWN WARP is shown by two examples.

WEAVES FOR SPECIAL FABRICS are quoted: Tricots (warp, filling and Jersey effects), Rib fabrics, Honeycombs, Imitation Gauze, Velveteen, Corduroy, Chinchillas, Quills, Plush, Double-plush, Tapestry, Crape, Terry, Worsted coating stitching, Huckes, and Bedford cords

HOW TO WORK THIS CHART OF WEAVES.

CAPITAL LETTERS of references refer to the plain weave and its sub-divisions.

SMALL LETTERS of references refer to twills and their sub-divisions.

NUMERALS of references refer to satins and their sub-divisions.

Example.—How to ascertain the construction of the weave at the right hand top corner of the chart; being the figured rib weave marked C C'? These two letters of reference mean that said figured rib weave is nothing else but the combination of the 2-harness 6 picks common rib weave warp effect C, and the 6 harness 2 picks combination rib weave filling effect C'.

Example.—The letter of reference e, underneath the first broken twill indicates that the same is obtained from the 1/3 4 harness twill e, (third weave on the second row; in other words, letter of references below each weave of any of the various sub-divisions refer always to the corresponding foundation weave.

Example.—Twill q and o, are the foundation for the eight combination twills filling drafting, said common twills are drafted 1 @ 1, the different designs being obtained by means of different starting.

Example.—The wide wale twill l' w', has for its foundation the 63° twills, marked also common twills marked l and w.

Example.—Granites marked 8 have for their foundation the 8-leaf satin, such as marked 12 the 12-leaf satin.

Example.—Backed by filling e 8, means the common 2/4 4-harness twill e, (fifth weave on second row) and the 8-leaf satin is used in the construction of this weave.

Example.—The complete design of double cloth, marked e 8 A, means that the common 2/4 4-harness twill (e), the common plain (A) and the 8-leaf satin (8) are used in the construction.

Example.—Rib fabric A, indicates that the plain weave forms the foundation. It will be easy to substitute different foundations in constructing weaves for heavy weights. In reference to single cloth weaves we only want to indicate that by following rules shown in the chart, millions of new weaves can be made up from it.

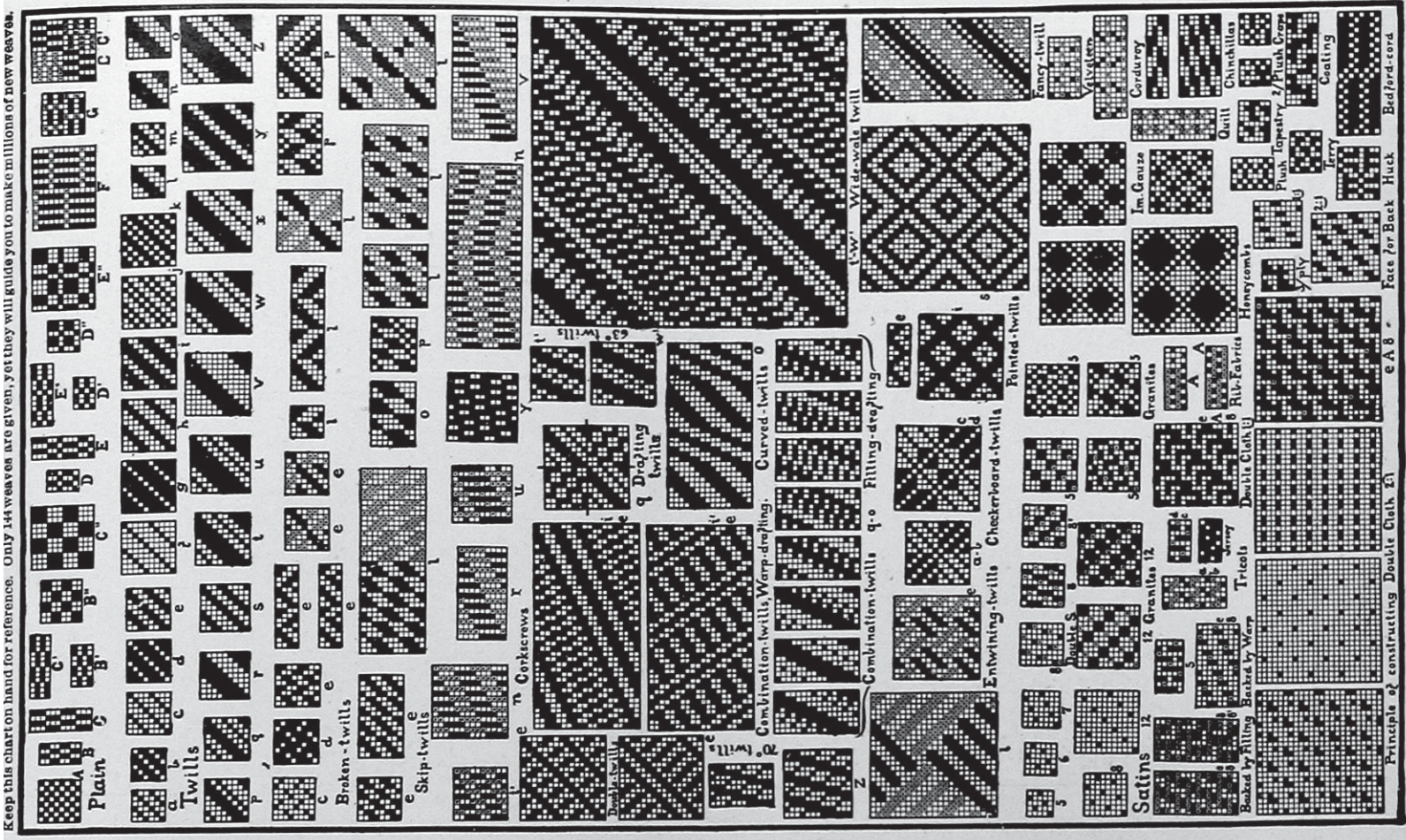

Keep this chart on hand for reference. Only 144 weaves are given, yet they will guide you to make millions of new weaves.

Principle of constructing Double Cloth 1 @ 1

LOOMS

FOR WOOLENS, COTTON, SILKS

AND ALL SPECIAL FABRICS

DOBBIES, JACQUARDS, WOOL COMBS

PRINTING DRUMS, REPAIR PARTS and SUPPLIES

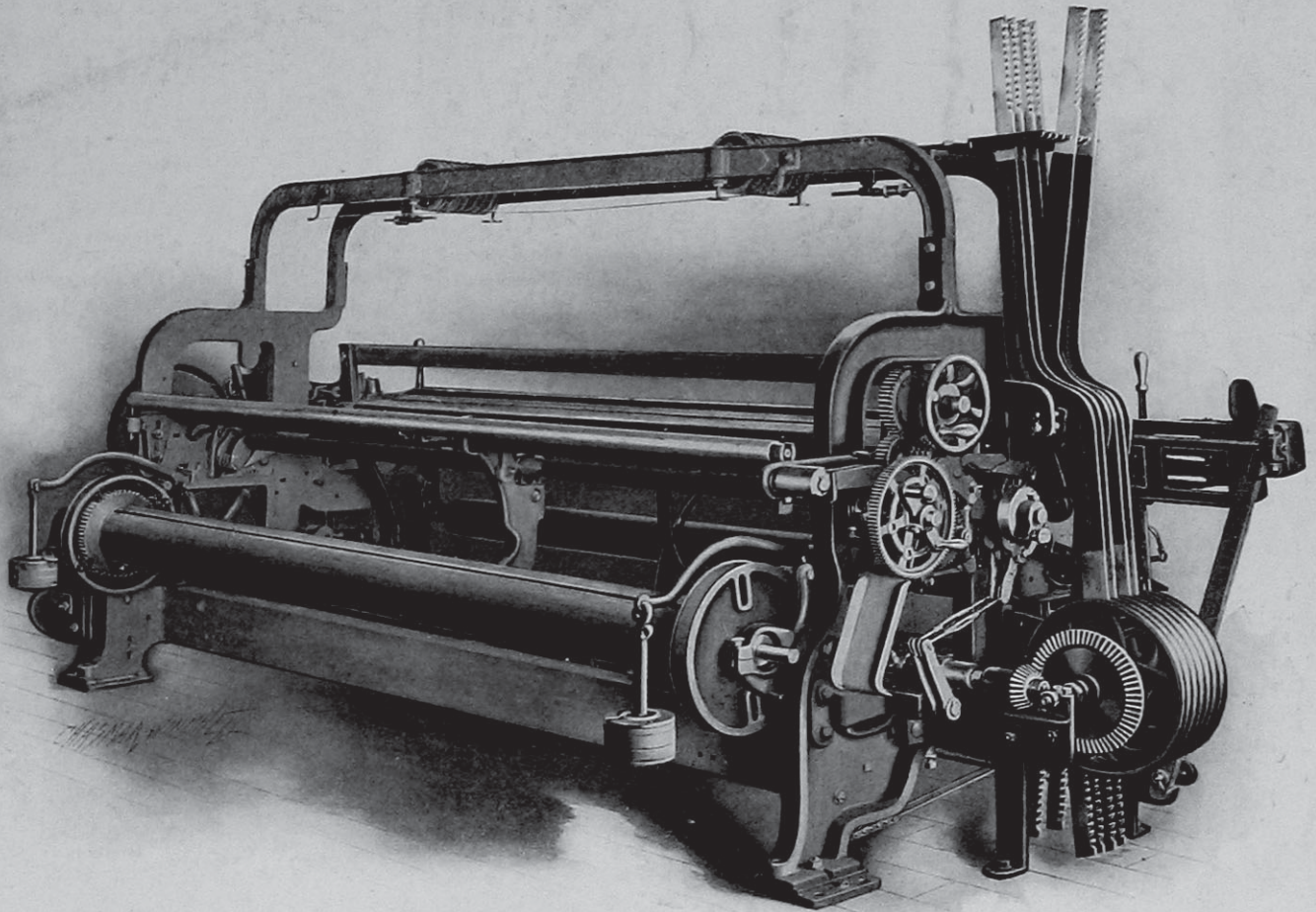

CROMPTON & KNOWLES LOOM WORKS

WORCESTER, MASS. PROVIDENCE, R.I. PHILADELPHIA, PA.

Southern Representatives—ALEXANDER & GARSED, Charlotte, N. C.

Foreign Representatives—HUTCHINSON, HOLLINGWORTH & CO., Ltd., Dabcross, England