

DYEING, BLEACHING, FINISHING, Etc.

TESTING OF CHEMICALS AND SUPPLIES IN TEXTILE MILLS AND DYE WORKS.

(Continued from page 209.)

As regards heavy metals, their sulphides have been found admirably well suited to this purpose; for the light metals, their carbonates; for acids, their silver, lime and baryta salts.

The elements, belonging to groups thus separated, are then subjected to further separation, and, lastly, the several elements are obtained in such an isolated state as to be recognized without any doubt.

The qualitative examination of substances for technical and commercial purposes is made, not for the purpose of ascertaining their chemical nature, for that in all ordinary instances is known beforehand, but with reference to certain possible or probable impurities and admixtures, either accidental or fraudulent, which may lessen their market value, or prove detrimental in the operations for which they are required. The nature of these impurities or admixtures may generally be anticipated, and the necessary operations of testing are therefore brought within a more limited range than is the case in the examination of substances whose chemical nature is more or less unknown, and when the probable nature of the elements or compounds present cannot always be determined beforehand even by the professional chemist.

In the general system of qualitative examination subsequently described, those elements only have been taken into account which are likely to be of interest commercially or technically. Although a rigid adherence to the entire system is not always necessary, still, to lay down any rules for deviating from, or omitting any portion of it, would be attempting a royal road to a knowledge which the analyst can only acquire by experience and careful observations of chemical phenomena.

In quantitative analysis, a knowledge of the elements present in the substances to be examined is presupposed. It is here necessary to devise means of effecting a perfect separation of each element without loss, and in such a form that its proportion can be accurately estimated. This has hitherto generally been effected by successively converting the several elements into insoluble and definite compounds which may be collected and weighed. Then by means of the law of combining proportions, the quantity of the element sought may be calculated. Thus, for instance, in the estimation of silver (Ag—from *Argentum*—atomic weight based on oxygen as 16=107.973) or chlorine (Cl—atomic weight based on oxygen as 16=35.462), the compound weighed in either case is represented by the symbolic formula

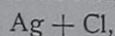

and substituting for the symbols their numerical equivalents,

$$107.973 + 35.462$$

we obtain the relative proportion of these substances in the compound weighed, and can calculate the quantity of either constituent in the weight of chloride of silver obtained, by a simple proportion. Thus if the

substance sought is silver = x , and the weight of chloride of silver obtained = y , then

$$x = \frac{\text{Ag} \times y}{\text{Ag} + \text{Cl}} = \frac{107.973 \times y}{107.973 + 35.462}$$

If $y = 1.726$, then $x = 1.299$.

With good manipulation this method of analysis satisfies all the requirements of precision and accuracy. It is unexceptionable for scientific research, but for many technical purposes, where the time occupied by an analysis is as much an element of its value as accuracy, it is wholly inapplicable.

However, as the law of definite proportions obtains not only in the composition of substances, but likewise for the reactions which take place between them, and as the greater number of quantitative analytical operations which come within the province of the manufacturer are of that kind to which the term *assay* may be very appropriately extended, their sole object being to estimate the proportion of some one ingredient of the raw material, it is not difficult to make such an application of this principle as will meet the wants of those engaged in commerce and the arts, be free from the disadvantages of the method mentioned and at the same time not be inferior to it in the accuracy of its results.

According to the formula for chloride of silver,

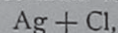

108 parts of silver require for conversion into chloride 35.5 parts of chlorine. Now by estimating the quantity of some suitable, definite compound of chlorine—such as chloride of sodium—requisite for converting into chloride, the silver x in a given weight of the substance to be assayed, the quantity of silver x may be easily ascertained, for it will bear the same proportion to the chloride of sodium consumed = z as the numerical values of their symbols,

$$x : z = \text{Ag} : \text{Na Cl}.$$

And if the chloride of sodium is added to the solution of the silver in the form of a solution, a given volume of which contains a known weight of the salt, the quantity z may be readily estimated by measuring the solution used. This method of analysis, which is called the volumetrical method, consists therefore in estimating the quantity of reagent necessary to complete some particular reaction, and is the reverse of the gravimetrical method, which consists in estimating the quantity of some definite compound produced by such a reaction. The insolubility of chloride of silver and the rapidity with which it settles after agitation, renders the application of this method to the estimation of silver extremely appropriate, but volumetric analysis cannot be used as much as gravimetric analysis.

(To be continued.)

POINTS ON ANILINOXYDATION BLACK.

By Dr. S. Culp.

The discovery of the sulfur blacks has given a great set back to the use of anilin black in cotton dyeing, more particular has this affected yarn dyeing. Since a short time, experiments are under the way to

also displace anilin black, by means of sulfur blacks, in connection with the dyeing of half-silks. Three prominent manufacturers of dyestuffs, *The Farbfabrikten of Elberfeld, The Cassella Color Co., and The Höchster Farbwerke*, have taken out patents by which the harmful action of the sulfur-natrium upon the silk fibre is done away with. The Elberfeld concern uses lactic acid, *i. e.*, lactate of natron; The Cassella concern glucose, and the Höchster concern natrium-bisulfit.

The process is carried on the same as with cotton, in a boiling hot dye bath, after which the goods are chromed and in the soapbath finished with wood, methylenblue, etc. The careful rinsing required for sulfur blacks must not be omitted.

That sulfur blacks will take the place of anilin black, in connection with the dyeing of half-silks, is hardly possible, since they can not equal it in beauty of color; neither will the developing blacks do this, which always will show a red hue and which feature greatly limits their use in place of the oxydation black, hence they will find use mostly only in connection with narrow ribbons, and where a nice full black is not as important. In all other cases it can not take the place of oxydation black and the manufacturer is perfectly willing to put up with the disadvantage that the latter process will tender the fibre, a feature which by proper manipulation of the process, *i. e.*, proper composition of the dye bath and properly carried on oxydation, may be reduced to a minimum.

The composition of the mordanting liquor used differs in the various dyeing establishments. To reduce tendering of the fibres to a minimum, the Farbfabrikten of Elberfeld recommend the use of Anilin-fluorat as patented by Thies and Cleff, substituting also a portion of the muriatic acid by organic acids. Using the proper composition in such a mordanting bath will give good results, if being careful not to substitute too large a proportion of organic acid for that of muriatic acid, otherwise the result would be a disappointment. The amount of chlorine used is also of great importance; too small an amount added will retard oxydation, whereas too large an amount used will tender the fibres considerably.

We will now describe with a few words the process which half-silk ribbons are subjected to by the oxydation. The ribbons are first, as usual, scoured with soap, care being taken that afterwards all traces of the latter are removed from the fabrics, after which the latter are thoroughly dried. The same are then entered into the mordanting bath and in turn guided between two squeeze rolls (made of hard rubber) after which they enter the drying chamber and in turn the steam chamber, where they are steamed. Both chambers are made either of iron, wood or bricks, the first and the last mentioned being lined inside with wood, whereas those made of wood have double walls with the space between filled with sawdust. The chambers have suitably mounted therein movable rollers over which the ribbons travel. Care must have been taken in the construction of these chambers for a good exit for the muriatic acid fumes

as formed during oxydation, since the latter will readily tender the fibres. Never raise the temperature in the drying chamber any higher than absolutely necessary. Don't use too dry nor too wet a steam for the steaming process; the first being the cause for a very poor black, and the latter for a bare black. To remedy either, all processes would have to be repeated, with consequent damage to the fabric.

After steaming, some dyers previously to chroming rinse the goods in water, whereas others chrome at once. The chrome bath is made up with from 2 to 3% double chromate of potash, eventually adding some sulphuric acid; the temperature of the bath depending on the shade of the black required. After chroming, rinse the goods well, eventually adding some carbonate of soda, after which finish dyeing upon the soap bath. No rules can be given for treatment, nor temperature, of this dye bath, it varies with the goods under operation and naturally requires experience. After the dyeing is completed, extract the goods without rinsing and dry them.

With reference to oxydation black upon wool, some of the processes are patented, they being based on counteracting the basic nature, *i. e.*, reducing capacity of the wool fibre, which prevents oxydation, either by means of chlorine or acids. These processes, however, are until now not used in practical work. Experiments have been also made to use anilin black upon manganesebister by a one bath method. In some cases the result is satisfactory, however, experience has demonstrated that the process is not a reliable one for obtaining an even, beautiful black; besides the process is a cumbersome one since three baths are necessary. On account of the many excellent blacks, exclusive of wood black, at the disposal of the wool-dyer, anilin black will be of little importance to him. (From *Färber Zeitung*.)

An Improved Process of Mordanting Wool.

This new process refers to mordanting wool with the aid of reducible metal combinations, especially with those of chrome. Formic acid is by the new process used as a reducing agent for the mordant, with the result of a complete utilization of the mordant bath, as the reducible metal combination in question, for instance bichromate of soda, it is claimed, is reduced to an extraordinary extent (100%), hence a great saving can be effected.

When formic acid is used as a means of reduction, dyeing experiments with hematoxylin have shown that when mordanting with the use of free formic acid, the chrome is completely reduced and fixed into the fibre. After mordanting with free formic acid, the bath is completely exhausted and as clear as water. Experiments have shown that the employment of about equal parts of bichromate and formic acid results in the most favorable effect.

The formic acid, it is claimed, offers the further advantage of a very slow action in the mordant bath, so that the chrome is decomposed very uniformly and the dyeings come out very evenly and uniformly.

When formic acid is employed, the addition of sulfuric acid, as in the other mordants, is not only unnecessary, but has in fact a deteriorating effect, since it has been shown that when sulfuric acid is also employed, the formic acid evaporates more easily. After the mordanting, there remains in the bath only the entirely indifferent formic potassium, which neither attacks the wool nor interferes with the spinning process said wool later on undergoes. In consequence, the wool does not need to be rinsed after mordanting, but only cooled off, and can then be dyed at once.

THE CARRYING OUT OF THE NEW PROCESS may be more clearly illustrated by means of the following example: — 100 kilograms (= 220 lbs.) of wool are put into a bath which contains about 2000 to 3000 liters (= 440 to 660 gallons) of water, 1 kilogram (= 2.2 lbs.) of formic acid and 1 kilogram of bichromate of potassium. In this bath the wool is boiled for one and a half to two hours. After cooling off the wool thus mordanted, the damp material is dyed in the manner intended. So, it can be put into a bath which contains 2000 to 3000 liters of water, 20 kilograms (= 44 lbs.) of anthracene blue (in dough) and 10% acetic acid. In this, the material is dyed in the manner of the alizarin dyeing. Formic acid may be employed in combination with bichromate, for all mordant dyes. The neutral salts of formic acid cannot be employed for the same purpose, because they remain entirely indifferent.

The described action of the free formic acid on the bichromate in the presence of wool is performed, as mentioned, at boiling temperature, thus easily exhausting the bath to an advantageous degree and without injuring in any way the wool. The process is a late German invention by Mr. S. Kapff.

A Machine for Dyeing the Yarn on Cops or Bobbins.

In dyeing yarn on cops or bobbins with indigo and similar colors, it is of great importance, not only to remove the surplus of dye liquor immediately after

operation and requires but very little labor on the part of the operator.

An endless traveling apron *a* carries the cops or bobbins *b* into the dye bath *c* at one end of the machine, and delivers them at the opposite end, said apron being provided with suitable holes and nipples *d* secured within said holes to receive the cops or bobbins, which are placed on said nipples by hand at the entrance end of the machine and are taken off at the delivery end, as the continuously moving apron slowly emerges from the dye bath. The slow and uniform motion of the apron facilitates the placing and removing of the cops or bobbins and also prevents the latter from falling off the said apron, while it passes into the dye bath and emerges therefrom on an inclined plane. The dye bath becomes but very slightly stirred or agitated by the cops or bobbins, while they are carried along through the same.

The cistern containing the dye bath *c* has a slot or a series of slots *e* in its bottom, and below the said slotted bottom is arranged a channel *f* communicating with the cistern through the said slots *e*. A suction pipe connected to an air pump (not shown in illustration) terminates in the said channel. The apron *a* carrying the cops or bobbins, while moving through the cistern, is dragged along the bottom of the same, thereby preventing the dye liquid *c* from flowing through the slots *e* of the bottom into the channel *f* below it. If the apron *a* were solid, no communication would exist between the cistern and the channel below its bottom, in spite of the slots therein. The apron, therefore, is perforated and in said perforations are secured hollow pins or nipples *d* on which the bobbins are mounted. When suctional force is applied to that channel *f* below the cistern, the liquid dye will be drawn into the cops or bobbins, thereby imbibing the yarn of the cops or bobbins from the outside to the inmost core. The liquor passes through the yarn and then through the perforations in the apron *a* in the channel *f* below the cistern, from where it is removed

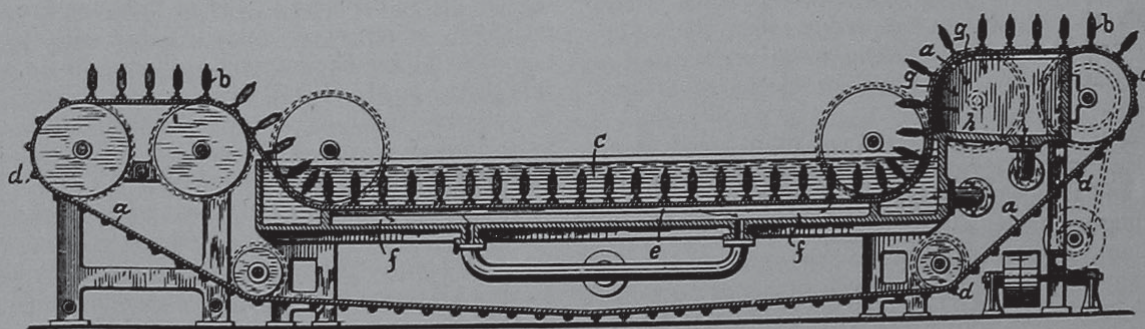

removing the goods from the bath, but also to force a current of air through the yarn, which acts to develop the color. If, after leaving the dye bath, the cops or bobbins are left to remain in their wet condition for any considerable length of time, no uniform shade is obtained, as the color becomes spotted.

The new machine, and which is shown in its longitudinal section in the accompanying illustration, performs the work most satisfactorily in a continuous

by the suction, which delivers the liquor to any suitable reservoir from which it may be returned into the cistern, and thus re-used.

The apron *a* on leaving the cistern is made to pass along the slotted top *g* of an air chamber *n*, which is connected to an exhaust pump. The slots in the top *g* will be closed by the apron, except at those parts where the said apron is slotted. It will be seen then that by means of the suctional force act-

ing from below the traveling apron *a*, air will be drawn from the outside through the cops or bobbins, the perforated apron and the slotted top of the air chamber *h*, and along with the air the liquid dye still contained in the yarn of the cops or bobbins will be removed from the yarn and passed into the suction channel from where it will be carried off through the suction pipe connected therewith and delivered into a suitable reservoir from which it may also be returned to the cistern and re-used.

New Colors of the Farbenfabriken of Elberfeld Co.

AZO ACID VIOLET A 2 B. This new color is especially adapted for the production of violet and claret shades, and as a combination color with Fast Green bluish, Wool Green, etc., for obtaining navy blues on ladies' dress goods. Cotton checking threads are not tinged. On account of its dyeing easily level it is furthermore adapted for the dyeing of yarn, which is required to possess good fastness to stoving, to alkalis and to a moderate washing alongside white wool. It yields very fine, bright red shades on silk, and can also be used for the dyeing of silk-unions (wool and silk) coloring the silk only slightly. It is also well suited for direct printing on wool. It levels well and produces violet shades of good fastness to washing. The shades are dischargeable, a good white with Rongalite and tin crystals.

ALGOLE BLUE 3 G paste is dyed in the hydrosulphite vat and is remarkable for its very fine greenish tone, the brightness of which is especially noticeable in light shades. It is chiefly adapted for the dyeing of cotton yarn for fancy woven goods, of piece goods for curtain cloth, etc.

BENZO BROWN 3 G C is extremely well adapted for machine dyeing, on account of its good solubility and easy level dyeing. It can be employed as a self-shade, but more especially as a combination color for the production of tans and fashion shades on loose material, yarn and piece goods. It is also adapted for the dyeing of half-wool, the wool then being dyed a somewhat deeper shade than the cotton. When dyeing halfsilk the silk comes out redder than the cotton. Dyed on silk alone the shades produced are fast to water. It is also well suited for dyeing of artificial silk.

PARA BROWN S C is dyed on cotton pieces in the usual manner in a bath containing Glauber's salt and soda, and after washing and drying is developed in the Padding machine with a diazotised Paranitraniline solution (2-2½ oz. Paranitraniline per gallon). In this way very full, reddish brown shades are obtained, which can be discharged a splendid white with Rongalite C or with similar discharging agents. Tin crystals and sulphocyanide of tin, produce half-discharges, zinc powder a good white. The fastness to washing of these shades is very good, and they are also possessed of a good fastness to light. On account of its excellent dischargeability, this dyestuff is sure to become a valuable product for cotton mills for dyeing napped goods as well as light cotton goods, for which a really good dischargeable substantive color yielding full brown shades was hitherto wanting. It is also

well adapted for the dyeing of loose cotton, piece goods and yarns. (Samples of Fabrics and Yarns dyed with these four new colors can be obtained by addressing the concern to 66 Lafayette Street, New York.)

Stains and Defects in Finished Cotton Goods.

Occasionally a finisher is troubled by the production on the finished fabrics of spots and stains of various kinds. The cause of these is sometimes very obscure, and not readily ascertainable, at others it is at once obvious. Although the subject is a very important one. Spots and stains are due to a variety of causes, some of which are in the cloth before the finisher takes it in hand, others are produced afterwards.

OIL STAINS.—Oil stains are very common. These are derived from the spilling or accidental throwing of oil from the machinery used either in the spinning, weaving or finishing processes, the exact period when they have been produced is rather difficult to tell. If in the spinning, the stains are mostly confined to either the filling or warp threads of the fabric, in the case of weaving stains they are more patchy and may either be on the warp only or on both warp and filling, or may have been produced on the cloth while it was being finished. When the cloth is stained during weaving or before, the oil itself may be removed during the process of bleaching. Although in some cases the stains may be removed, yet it is not always so. They remain on the cloth and the innocent finisher often gets the blame for them.

EFFECTS OF IRON.—In the case of colored goods these may be stained by particles of iron, etc., in the water used. This acts on the dye and leads to changes of shade, again the cloth may have stains of metal in it before dyeing and these will be sure to fix the coloring matter in greater abundance. Stains may be produced by particles of dust, etc., floating about the air of the finishing works, and these settling on the cloths lead to blemishes of various kinds.

MACHINERY DEFECTS.—They are often produced by defects in the machinery, and in this case are characterised by being more or less of the same shape and occurring at regular intervals. A scratch or indentation of the bowls of a stiffening mangle will give rise to an extra deposition of mixing, which will show itself as an uneven place. The cause of such stains is soon found out and it is easily remediable.

COLORS RUNNING.—In the case of printed and woven goods, finishers are sometimes troubled with the colors running. This may be due to the color itself being a loose one or not properly fixed on the fibre, and in this case it can scarcely be considered the fault of the finisher that the colors run. The only thing that can be done is to minimise the evil as much as possible by working the pieces in as little water as possible and getting them finished quickly. In other cases, the fault may be due to the finisher using ingredients in his mixings which act on the color as solvents and so cause the running. In such cases it is necessary to avoid using the ingredient which does the mischief, if necessary substituting something else for it. Where the trouble lies must be found out by experiments with each

ingredient of the mixing in turn. The substances which are likely to cause mischief are the chlorides of zinc, calcium, and magnesium, soap and soap softeners, caustic soda and soda crystals.

COLORS CHANGING.—Another defect is the changing of the colors of the cloths. This has become of late years a matter of importance, owing to the great use of congo red, benzopurpurine, and similar bright reds, which are easily affected, especially by acid substances. These reds are liable to turn blue or darker during the finishing, and this is especially likely to happen when chloride of zinc or magnesium are used in the mixing. When this is found to occur, the best plan is to run the pieces through the hot water mangle to remove as much as possible of the mixing, then to mangle in a soap liquor to which a little soda crystals has been added. Then the piece can be finished as usual. The mixing for these reds should be made slightly alkaline, and soluble oil is an excellent body to use with these colors. On the other hand, some colors would be deteriorated by the use of an alkaline mixing, then the latter must be kept as neutral as possible. Certain blacks are reddened by the use of mixings of an acid character. Blue prints done with albumen are also liable to be decolorised by acid mixings. Finishers would do well to test the action of their mixings by small experiments on every new lot of colored goods they receive before passing them through the process, they would then be in a position to prevent any possible damage to the colors.

MILDEW.—One of the troubles which beset a finisher is the production of mildew stains on his cloth. These stains often make their appearance unexpectedly and when least expected, generally after the finished goods have been stored in a warehouse for some time. Mildew, however, does not come so often on white and colored goods as on gray cloths. Mildew consists of a number of spots of various colors, mostly brown, gray, or green, and of various shapes. They are due to the development of fungi on the cloth, which get their nutriment from the size with which the cloth is filled, especially when flour has been used. Hence the reason why gray cloth being sized with a flour size is more liable to mildew than finished white or colored goods that are mostly filled with starchy size not so readily subject to mildew.

The essential conditions for the production of mildew or mould are (1) damp; mildew never comes in dry places or on goods which are kept in a perfectly dry place; (2) want of air; on goods that are constantly exposed to air mildew is but rarely, if ever, seen; (3) the presence of suitable bodies on which the fungi feeds, such as flours of various cereals, nitrogenous bodies, starchy and fatty bodies. These last are, however, not so sustaining to fungi as flour and nitrogenous bodies, and hence are gradually displacing them with advantage in sizing and finishing cotton.

The growth of mildew fungi may be prevented by the addition to the size or mixing of many bodies which kill the fungoid spores present in the size mixing or which may find their way onto the finished cloth. These bodies are known as antiseptics. Mildew makes its appearance often quite unexpectedly.

It has been known to develop during the transit of goods to distant places, and in this case the goods have been found to be rather damp and heavily sized. In all cases where cotton goods have to be sent abroad, care should be taken to avoid heavy sizing and to use antiseptics. A brief description of the more common varieties of mildew will be useful.

Green Mildew.—This is a common form in which mildew makes its appearance on cloth. It is generally due to two species of fungi, viz., *penicillium glaucum* and *aspergillus glaucus*, which are closely allied to one another, but are distinguished by the manner in which the spores are attached. In the former, the spores are on branches, while in the latter they are attached to the head. They grow rapidly and generally form rather large patches.

Brown Mildew.—This is frequently found on cloth and is due to various species of fungi, *puccinia graminis* is, perhaps, the commonest of the brown species. This and the brick-red are frequently mistaken for iron stains, the color of which they closely resemble. They are easily distinguishable by the manner in which they occur in small spots, often in a ring shape (it is rare that iron stains assume this form), and by the fact that they do not give the characteristic blue reaction with potassium ferrocyanide.

Brick-Red Mildew.—This sometimes occurs, but the species which form it has not been definitely made out. It grows rapidly at first, but has no great vitality, and after a time the development stops.

Yellow Mildew.—This is a common mildew to find on cloth, and occurs in large rather irregular patches and spots. Not requiring much air for its development, it extends much more into the folds of the cloth than do most of the other forms of mildew. It is due to this yellow variety of *aspergillus glaucum* (*erotium*) and also to *ordium oranteacum*.

Black Mildew.—This is due frequently to fungi belonging to the genus *filletia*, and is occasionally found on cloth. It is very rapid in its growth, and has been known to develop in one night on cloth. *Purple mildew* is also known but is rather rare in its occurrence. *Bright pink mildew* is of rare occurrence on cloth, but is met with now and again.

It is not fair to charge the finisher with all cases of mildew that may appear. The packer and merchant have also a hand in helping to produce this undesirable effect. Even if the finisher does his work well and turns it out in a perfect condition it will often mildew if kept in a damp place, especially if the starch and mineral only have been used in the finishing. This filling will not mildew if the goods are kept in a dry place, and to charge the finisher with the defect which is owing to their being kept in a damp place is most unfair. The fault is the warehouseman's. Again, if the goods are packed in tin cases in a steamy packing room, the goods will be sure to mildew during transit to their destination, and the fault here is the packer's. An analysis of the cloth will show where the blame lies. If the amount of moisture is low, no deliquescents used in finishing and the filling on the cloth simply consisting of starch, china clay and mineral, the finisher is not to blame for any cases of mil-

dew. As, for instance, the following case which came under the writer's notice:—

	Actual fibre	74.62	per cent.
Cloth	Natural moisture	5.97	"
	Moisture	1.03	"
	Oiling matters	0.32	"
Filling	Starch matters	5.86	"
	Mineral (sulphate of calcium)	6.34	"
	China Clay	5.86	"
		100.00	"

In this there was no excess of moisture, no deliquescent matters were used, nothing but mineral matters and the necessary binding material, and the finish was a calender finish. Still, mildew appeared about eight months afterward, and the fault was evidently not in the finishing, for either the goods had been packed damp or stored in a damp place.

Mildew cannot be got out of the cloth when once it gets in, but when only present in small amount it does not exert any tendering action on the cloth. When it is developed very strongly mycelia of the fungi growth enters the fibre and undoubtedly weakens the cloth very much. The great fault of mildew is that it spoils the appearance of cloth and renders it quite unsaleable and worthless. It is not, however, nearly so prevalent as it was some years ago.

FAULTY PACKING.—Stains sometimes appear on the cloth as a result of faulty packing. Cases have been known in which the marking of names on the outside wrapper of a bale of goods have been transferred, so to speak, to the goods inside, and this happens most frequently when coal tar has been used as a marking material.

The use of oiled or water proofed paper has become very common. If the waterproofing is not thoroughly hardened, there is a liability for it to mark the cloth. All papers, wrappers, etc., used in packing, ought to be as pure as possible, and free from oil, grease, metallic stains and sizing materials. Otherwise there is a possibility of the cloths becoming more or less affected. It often happens that the origin of such stains is very obscure, and by no means easy to find out. That the fault lies with the wrapping papers, etc., is generally about the last thing thought of. (From Cotton Finishing, Just Published by Heywood & Co., Ltd.).

PRACTICAL POINTS ON THE SHEAR AND THE SHEARING OF WOOLEN AND WORSTED GOODS.

(Continued from page 210.)

The ledger blade. The same is shown by means of letter of reference *M* in Figs. 1 and 2, and *B* in Figs. 3 and 4, and is made of two sheets of metal, steel and iron, the latter being welded to the steel for reinforcement. So as to expose the steel and prevent the iron from coming near the cutting point, the blade is put upon a grinder and a bevel ground on the face, in this way also giving the cloth under operation a somewhat freer passage between the rest and the blade than otherwise would be the case; however to expose the steel at the end of the blade is the chief reason for putting this bevel on the blade. Since one-half of the blade laterally is steel and the other half iron, any time

that the iron is ground away again, the blade is as good as ever. To repair a ledger blade when its steel portion is worn down, is technically known as facing the blade, *i. e.*, put a new working face on, and requires a grinding machine.

To set a new ledger blade, is a most important work for the finisher. To do it, first remove the revolver and then take out the casting to which the old ledger is riveted. Take out all set screws and insert the two rows of adjusting set screws in the new casting until you can just about feel them coming through on the under side, but not through enough for them to have any bearing on the bed when you put the new ledger blade in the frame of the machine, after which insert the binding set screws, tip the blade to somewhere near the right pitch and tighten down the end binding set screws just sufficiently to hold blade in position placed, but not enough to make them rigid. There are two set screws, known as ear screws, one of which screws into the upper part of the ledger casting and the other into the frame of the carriage through the shoulder upon which the blade casting rests. The lower set screw set back until it has no bearing, and the upper one set so as to allow sufficient room to work on them. On the frame of the carriage are two marks, one on each side, to indicate the exact position where the journal of the revolver rests, and when then line up blade to these marks. Bring centre mark on the journal of revolver up the same level with the mark on the frame used as a centre mark in setting the blade. Next replace revolver and tip the ledger blade from the front side until it rests lightly against the revolver and tightens on the middle binder to hold it in position. Test if contact is evenly all along and if finding any places a trifle out of the way, work on the adjusting set screws which govern this particular place.

The ledger blade ought to be honed once a week and never drawn upon so hard as to prevent the revolver from working easily, and which must be kept well oiled. If its cutting blades are allowed to get hot, the nap will be burnt in streaks as the cloth passes under them; tender goods are also made by hard cutting down upon the body of the threads and cloth, instead of merely running over the nap.

The Revolver, *i. e.*, the fly blades. The cutting blades also called the fly blades, in the revolver, or shear cylinder, consist of strips of soft iron, with a thin, narrower strip of tool steel rolled into the front upper edge. The soft steel on the back upper edge is beveled away, so that nothing but the tool steel edge bears against the ledger blade. When the cutting blades of the revolver have worn down far enough so the soft iron appears on the back edges, the revolver should be sent to the builders of the shear for backing off, since if the soft iron runs on the ledger blade, both systems of blades will rough up, dull quickly, heat and there is great danger of drawing their temper. Should the revolver become tapering in diameter, hollow in the middle, smaller at the ends, out of round or low in spots, as will be readily understood, it must be ground.

The sharpness of the blades of the revolver can be judged by the shear-tender, after a little practice, by the feel of the edges. When the same are keen, they will catch the skin, if rubbing your fingers against and across them, whereas when they are dull, they feel smooth and almost rounded when running the finger lengthwise on them, and will not cut the skin of your finger while doing so, even under considerable pressure.

Before shearing with either a new or repaired set of blades, revolver blades and ledger blade, they must be ground together a few minutes and the ledger blade brought up just a hair, by turning down the upper set screws. It will need but a trifle of emery and oil. As soon as the blades are ground and adjusted so they will cleanly cut wet tissue paper, their whole length, run them in oil alone for a few minutes. Then hone and clean.

When a new or repaired set of blades is sent out by the machine builders, it is of course perfectly adjusted and tested before shipment, and is ready for immediate use, however, the jar and shock of transportation necessitates this little grinding together and readjustment, and if you should try to run the blades without this little grinding, the ledger out of true, will in turn require a much more extensive grinding afterwards to correct trouble, besides shorten the life of the blade.

The operation. In starting to shear a piece of cloth, the same is first threaded through the machine by attaching (wiring) one end of the cloth to an apron, previously threaded through machine, and then sewing the two ends of the cloth together. Care must be taken to make a good, fine seam, using for this purpose a regular Mill Sewing Machine. A carefully made seam will more than repay for the time it takes to do this, and it will enable the attendant to finish the ends of the piece as nicely as the middle, and as close as possible to the seam, whereas if a poor seam is made, the goods may be more or less streaked for about a yard at the seam. The machine is then started and the cloth run through the required number of times until the proper length of nap remains, the shear cylinders being always raised out of the way when the seam is about to pass under them. At the last run, the seam is taken out and the cloth folded on the table Y, see Fig 2, a new piece of cloth, or the apron, having been previously attached (wired) to the end of the cloth, before the latter runs out of the machine.

During shearing, the fabric must be kept smooth and free from wrinkles. As a rule the trouble rests with the shear-tender, provided the cloth does not run smoothly and when you see a shear-tender running continually from one side of the machine to the other, in order to keep the fabric running straight and smoothly, it is generally a sign that the man has not paid attention to his work. Put the cloth into the scray in a neat way, do not throw it in any old way, and you will notice that the man has the best of it with his work if following the first mentioned plan as soon as the machine is started, since the cloth will run smoothly and he will not have to

run from one side of the machine to the other, in the effort to keep out wrinkles. While the cloth is in motion, the shearer's eyes are to be on the cloth, and he cannot do this provided he has continually run back and forth of the machine to keep out wrinkles, for while a man is doing that he cannot see what is going on at the cutting point, and which is the most important place for him to watch.

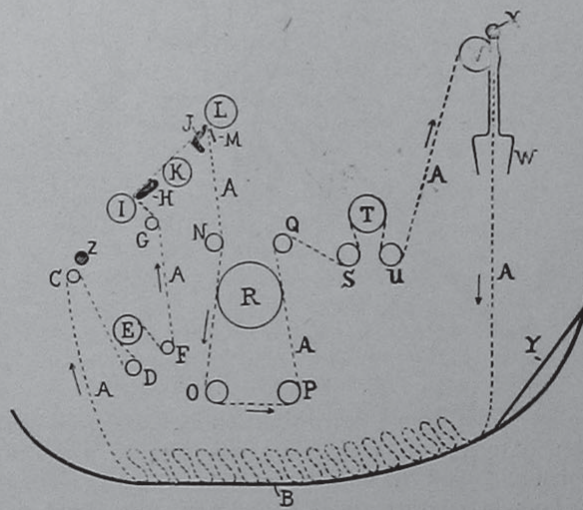

FIG. 1.

In connection with shearing dress goods on the rubber rest shear, the tension must be such so as to draw them over the rest sufficiently tight so as to

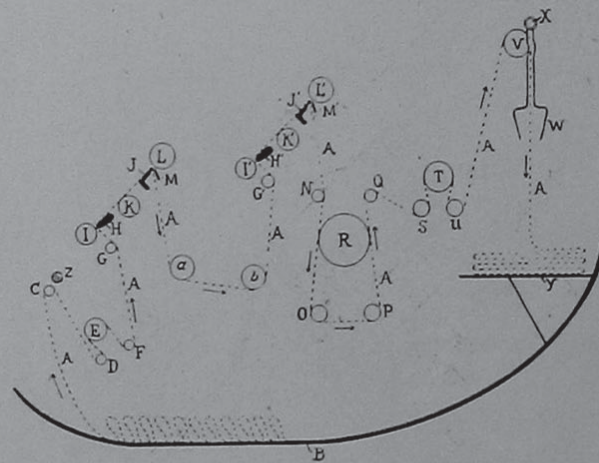

FIG. 2.

bury the knots in the tube, and provided the rest contains a list saving attachment, cover the heavy card clothing on the end of the bar which brings the cloth in contact with the feeler catches, with cloth, so that the teeth will not catch in the goods and pull out and break threads; preventing at the same time, on account of the jumping caused when the teeth catch in the cloth and then let go all at once, the goods from jumping towards the blades, and in turn be clipped at their sides.

Fabrics having longer selvages than the fabric itself, are of the greatest annoyance to the finisher and such selvages must be avoided in the construction of the fabric, for which reason, it will not pay to use

any old remnants of yarn for salvage warp. The tension given to the cloth at the shearing must be sufficient to draw the selvages down so that they are not cut by the fly blades. Long, *i. e.*, loose selvages will

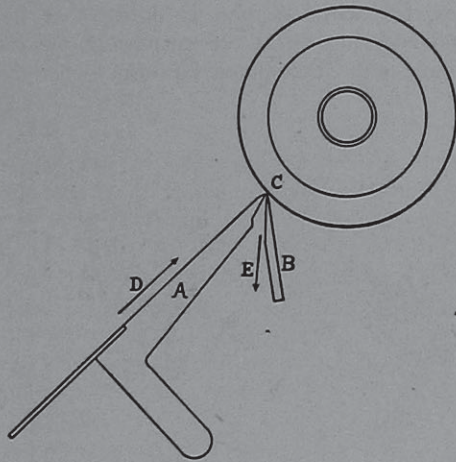

FIG. 3.

scallop if not drawn down tight enough and said scallops in turn will be more or less clipped, a feature which will spoil the appearance of any fabric, no matter how well its construction, and perfect its finish will be.

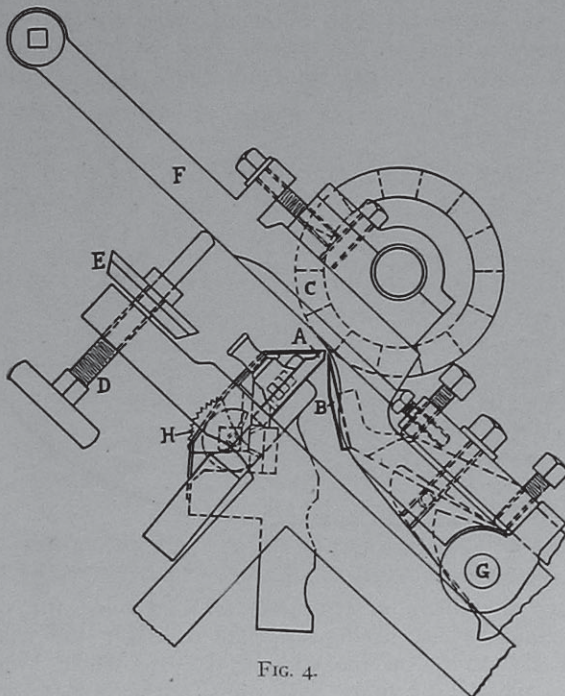

FIG. 4.

With reference to flexibility of the rest, the same is arranged in different ways in different makes, one plan being to raise or lower the face of the rest from the bottom, by means of screws. The top strip of the rest as contains the groove, in turn is connected with a series of screws placed six inches apart. The heads of these screws are square and by turning them one way or the other, by means of a socket wrench, the strip is either lowered or raised, as the case may require.

Care must be taken by the finisher that the rest is set in proper position, in order that the nap is presented to the cutting point of the fly blades properly, since if the rest is set too high, such an arrangement will crowd the nap into the blades too soon, and cause them to pull, whereas if the fly blades are set too low it will bear against the ledger blade, in turn prevent the cloth from passing freely between the latter and the rest. When the fly blades are set at the lowest point, the highest part of the cloth, as it passes over the rest, should come exactly in front of the cutting point of said fly blades, *i. e.*, the point where the fly blades come in contact with the edge of the ledger blade. Be careful to adjust the friction by which the draft-roll on the back of the shear is turned, so that there is a slight tension to the cloth. Oil the swab when starting the machine, and after this oil oftener and at less intervals; insuring yourself in this manner every time when starting a new piece against hot blades as well as oil spots on the cloth, features which will be the case if oiling heavily, at long intervals, in order to save the trouble of oiling oftener.

The common swab is of cloth and is tacked to a round or square stick, and this stick is placed on the cap of the journal box frame, and by means of suitable holes bored into it, is held on and overlapping the blades of the cylinder by the top screws. The cloth part hangs rather straight, in fact almost too straight, to retain the oil to any great extent, thus provided its oiling is done carelessly, the oil will drop off and in turn on the cloth to be sheared.

The object of the swab is to keep the blades on the cylinder cooled, since said cylinder revolves at a high speed (from 1000 to 1500 revolutions—according to make of machine—per minute), again the cylinder is running against the ledger blade, which has a tendency to heat them, and which must be avoided. If, with a proper oiling of the swab, there should still be a tendency for the blades to get hot, it then is a sign that the blades are running too hard, that is, the ledger and cylinder blades have been drawn together so tightly in order to make them cut, that the friction thus produced, speedily heats them.

Provided you oil evenly, but see that the oil as applied for this purpose works on to the swab in streaks, it then indicates that the oil is drawn from the swab more abundantly in such places, and when possibly a rough place in the revolver is at the bottom of this, or else the blades of the revolver are worn down, the iron on the back of them striking the ledger blade. An improved swab is also frequently met with, the same consisting of a strip of perforated leather fillet, such as is used by card clothing manufacturers. This leather swab rests directly against the fly blades of the revolver and has two strips of felt on its outside to retain oil and apply it to the leather beneath. This kind of a swab wears much longer than a common swab, and applies the oil evener and also acts as a stop on the blades of the shear cylinder to keep them sharp.

(To be continued.)

THE
**Grosser
 Knitting
 Machine
 Company**

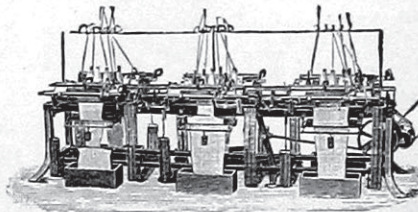

MAX NYDEGGER
 260 West Broadway, -- NEW YORK

Exclusive Agent
 for the Best
 Foreign Machine
 Manufacturers

REPRESENTING

C. F. GROSSER, Markersdorf, Bez. Leipzig: Manufacturer of all kinds of flat Latch Needle Knitting Machines, Lamb style, to be operated by hand or automatically run by power. Best machines for manufacturing Jackets, Coats, Sweaters, Underwear, Fancy Knit Goods in all styles, Gloves, Stockings, Shaker Goods, Sporting articles, Jerseys, etc. Spoolers and Winders especially adapted for Hosiery and Knit Goods Factories.

C. HILSCHER, Chemnitz: Manufacturer of "Cotton Hilscher" Machines for fine gauge full fashioned Hosiery, Jerseys and Underwear, Rip Top Frames "Cotton and Hilscher" style.

WILH. BARFUSS, Apolda: Manufacturer of WARP KNITTING machinery, double Rib Frames, etc., for all the fancy articles, Shawls, Hoods, Caps, Fascinators, etc. Glove fabric in Silk, Cotton and Worsted, Lace Gloves, etc.

C. TERROT SOEHNE, Cannstatt - Stuttgart: Manufacturer of French Circular Frames, producing finest Balbriggan for Underwear, Fancy stitches, Lace work "Poros Knit." Machines for using Hard Worsted or Lisle, Yarns, Silk, etc.

JULIUS KOEHLER, Limbach: Manufacturer of the "DIAMOND" Overseamer for all selvedged articles as Full Fashioned Hosiery, Underwear and other knit articles. LOOPERS, producing finest elastic and flat seam. If you make Hosiery or Underwear YOU cannot be without it.

BEST GERMAN LATCH BEARD NEEDLES. Quality is the money saver. If you want anything in Knitting Machines, etc., write to me. My long experience in the Knitting line is yours for the asking. Information and samples supplied upon application.

JACOB K. ALTEMUS

Est. 1865

2824 N. 4th St., Phila., Pa.

Builder of Textile Machinery for handling all kinds of yarns, tapes, etc., by reason of the knowledge, skill and vast experience in the manufacture of the various fabrics, the machines required in the successful operation of the various departments at the lowest possible cost; is in a position to give advice regarding the increasing of efficiency in any department or machines along these lines.

It has always been the aim to command confidence and respect in business relations and by constant attention to the products and hard earnest work it has gained the appreciation of the trade through the principles of confidence and square dealing.

If you are interested in increasing the efficiency of your plant, or some department or machine, write me and I will be glad to take the matter up with you. Ask for descriptive list.

BUYERS' INDEX—Continued

Power Transmitting Machinery. Philadelphia Drying Machinery Co.	Mason Machine Works. Sipp Electric & Machine Co.	Twisters. Draper Co. Mason Machine Works. Whitin Machine Works.
Presses. Philadelphia Drying Machinery Co.	Silk Yarns. Cheney Bros. Littauer, Ludwig. Ryle, William, & Co.	Warp Stop Motions. Crompton & Knowles Loom Works. Draper Co. Kip-Armstrong Co.
Printing Drums. Crompton & Knowles Loom Works.	Spindles. Draper Co.	Winding, Beaming and Warping Machinery. Altemus, Jacob K. Draper Co. Whitin Machine Works.
Pumps. Philadelphia Drying Machinery Co.	Spinning Frames. Mason Machine Works. Whitin Machine Works.	Wool Combers. Crompton & Knowles Loom Works.
Quillers. Sipp Electric & Machine Co. Whitin Machine Works.	Spinning Rings. Draper Co.	Woolen Machinery. Altemus, Jacob K. Crompton & Knowles Loom Works. Hunter, James, Machine Co. Philadelphia Drying Machinery Co.
Railway Heads. Mason Machine Works. Whitin Machine Works.	Spoolers. Draper Co. Whitin Machine Works.	Woolen Yarns. Littauer, Ludwig. Queensbury Mills.
Reels. Draper Co. Sipp Electric & Machine Co. Whitin Machine Works.	Tanks and Tubs. Philadelphia Drying Machinery Co.	Wool Washing Machinery. Hunter, James, Machine Co. Philadelphia Drying Machinery Co.
Revolving Flat Cards. Mason Machine Works. Whitin Machine Works.	Tapes, Braids and Edgings. Chapin, George W. Weimar Brothers.	Worsted Yarns. Camplon, Richard. Littauer, Ludwig. Queensbury Mills.
Ribbons and Piece Silks for Trimming Knit Goods. Cheney Bros.	Temples. Crompton & Knowles Loom Works. Draper Co.	Yarn Testing Machinery. Sipp Electric & Machine Co.
Shuttles. American Textile Specialty M'ch'y Co.	Threads. Chapin, George W. Littauer, Ludwig.	
Silk Machinery. Altemus, Jacob K. Crompton & Knowles Loom Works. Halton's, Thomas, Sons.	Tinsel. Littauer, Ludwig.	

TEXTILE ENGINEERING**THE ELECTRIC DRIVE FOR TEXTILE MILLS.***(Continued from page viii, February issue)*

7. By using curve tracing instruments, it can easily be ascertained whether the separate departments of the mill are started on time or stopped before closing time, also if full load and full time are kept on the machines during working hours. This enables a check to be kept on both the overseers and the operatives, and also on the mechanical department, not only as to the power taken but also as to the amount of work and production from the power.

8. Motors can be located so that each machine is driven by a separate motor. This eliminates all belts and flexible factors in the power system and their consequent losses and variations, the machines are driven at a constant rotative speed by a direct and positive application of the power. Better lighting and ventilation are secured by the use of individual motors because of the absence of shafting and belting, and therefore greater cleanliness and better sanitary conditions are possible.

9. Independent operation of any section of the mill, if the group system be adopted, and independent operation of machines, if the individual motor drive be used, are possible. If overtime work is required, or in case of a breakdown of any machine or group, one machine or group of machines may be operated or stopped without affecting any other section or machine. In such cases the power consumed is in direct ratio to the work done and the whole power plant does not have to be operated just to run a few machines. Liability of the complete stoppage of the mill is reduced to the minimum if two independent

units are installed, only one of which is an item of cost at a time and only one of which need be operated.

10. Uniformity of speed of the machines is secured, due to the even speed of the prime mover, which is transmitted with exactness to the motors and by them to the machines. There is an absence of the fluctuations of both speed and power which are so noticeable in a belt-driven machine that gets its power from a steam engine, the speed, even with a heavy fly-wheel, varying materially throughout the stroke and causing fluctuations and pulsations that are very harmful on high speed machinery like spinning frames. These pulsations, in many cases, may be multiplied throughout the mill in their intensity, and should a weak or defective thread encounter this pulsation it will be apt to break and thus cause a stoppage of the machine. It is due largely to this absence of fluctuations and to its uniform speed that the electric drive is able to so increase the amount of production per machine.

11. There is an improvement in both the quality and quantity of the production when the electric drive is used, this increase being most marked when the motors are directly connected to the machines. There is as great an increase in production by the direct drive over the group system as there is by the group system over the old belt and shafting drive. When the motor is attached directly to any textile machine, the speeds are maintained at the theoretical maximum and are constant, this accounting for the increased production, which will average from 5% to 7% of the total output.

12. Lower cost to small manufacturers. The cost

(Continued on page x.)

GEORGE W. CHAPIN
COTTON YARNS
 TAPES, BRAIDS, THREADS
 LACE EDGINGS
 229 CHURCH STREET 231
 PHILADELPHIA, PA.
 N. Y. Office, 350 Broadway
 R. E. SCHNEEBELI, Res. Manager

LUDWIG LITTAUER
 Successor to Moeller & Littauer
YARNS | Thrown Silk | **YARNS**
 Artificial, Shappe and Spun Silk
 Domestic and Imported, Plain
 Gassed, Mercerized and Polished Cotton
 Polished and Glazed Threads
 Mohair and Worsted
 Tinsel
 Turkey Red
109 GREENE ST., NEW YORK
 Best Quality Harness Twine

The West Indies Chemical Works, Limited
 Manufacturing Only the One Product
PURE LOGWOOD
EXTRACTS
 WE ARE ABLE TO GIVE YOU THE BEST
WORKS—JAMAICA, WEST INDIES
 (where the Logwood Grows)
NEW YORK OFFICE, 26 CLIFF ST.

WILLIAM RYLE & CO.
 Foreign and Domestic
Spun Silk Yarns and Noils
 Domestic Thrown Silk of every de-
 scription. Fine Pure Dye Silks for
 the woolen trade a specialty. Import-
 ers of European and Asiatic Raw Silk
54 Howard St. NEW YORK

FIRTH & FOSTER CO.
DYERS and FINISHERS
 OF PIECE GOODS EXCLUSIVELY

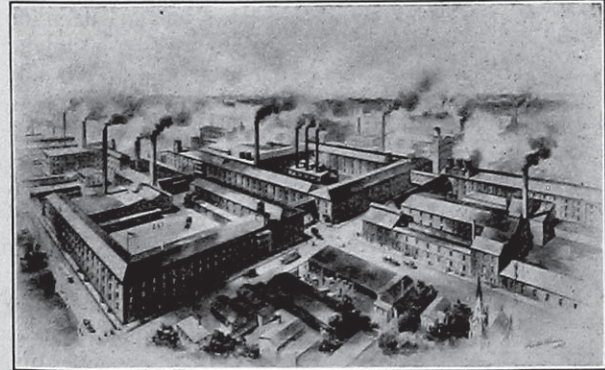

*The best equipped plant for the DYEING
 and FINISHING of fine wool and worst-
 ed goods, also silk and wool fabrics.*
 EMERALD, YORK AND ADAMS STREETS
PHILADELPHIA
 NEW YORK OFFICE: Silk Exchange Bldg., Room 702

QUEENSBURY MILLS
 H. HODGSON, Pres. and Treas. FRED. HODGSON, Gen. Mgr.
MOHAIR
 FLYER SPUN YARNS *Mohair Tops and Yarns for Weaving Single and 2-ply* ALPACA AND WORSTED YARNS
WORCESTER, MASS.

ESTABLISHED 1885 INCORPORATED 1888 A. H. HOWARD, PRES. AND MGR. HERBERT MIDGLEY, SUPT.
HOWARD BROTHERS MFG. CO.
 MANUFACTURERS OF
CARD CLOTHING
 Hand Stripping Cards, German and Domestic
 Heddles for Cotton and Woolen Mills
 Revolving Top Flats Remounted
 Fillets Redrawn
 PHONE 1070. LOCAL AND LONG DISTANCE
44 and 46 Vine Street, Worcester, Mass.
 QUALITY SELLS OUR GOODS

for a steam plant or the necessary heavy lines of shafting and belting is a serious consideration to the small mill. For many reasons, a boiler and engine cannot be put in a third or fourth story, whereas a small motor can be placed anywhere, and if electric power be available, the current necessary to operate the machinery can be purchased and only that used need be paid for. The cost of coal, combined with the cost or the rental of property on which to erect a steam plant in a city is often great enough to make the difference between power generated at the mill and power bought from a central supply an item large enough in itself to pay a good profit to the manufacturer if he buys his power. Especially is this true when power is used intermittently or there is a variable load, for while idle the power plant produces nothing and is a source of expense for coal, employees, etc., whereas if the power is purchased, the only expense for power is when it is in use and productive. The belting and shafting with electric group drives are light, therefore cost less to install and maintain, and there is less lost power from slipping, friction, etc.

13. It is possible with the electric drive to keep an accurate watch on the productiveness of any machine or group of machines and their operatives, also on the power consumption of machines, their stoppages, etc., and any deviation from the normal will be quickly detected. A record kept of the production of a machine will soon show whether it is working at its full capacity or not or if it is being stopped too often, and the mechanical department of the mill can learn at any time the necessity for an examination of the machinery. With an electric drive, a meter can be placed in the circuit supplying the power to any machine or set of machines and the instantaneous power or the total power for any given time can be measured. This will at once show if the machine is working properly or not and if its power consumption is at variance with its rate of production.

(To be continued.)

THE LIGHTING OF TEXTILE MILLS.

(Continued from page 216.)

Efficiency of Electric Lamps. When considering the question as to which type of lamp is best to use in the mill, there are many factors requiring attention, such as the cost of lamps and of their installation, cost of wiring, etc., cost of electric current required, cost of maintenance, repairs and replacements, attention required, etc. The quality and the intensity of the light and its effect on colors, vision, etc., also are considerations. Where a bright general illumination is required, enclosed arc lamps are better than incandescent lamps, unless these are used in clusters, the Moore lamp being better than either. Where light is required in restricted areas, incandescent lamps are better, used individually over machinery, etc., near the object to be illuminated.

As regards maintenance and attention, the incandescent lamp is generally less in cost than the arc lamp. The latter require daily attention to remove the old carbons and put in new ones, globes must be

cleaned, etc., while the only work required by the incandescent lamp is to unscrew burnt-out lamps from the socket and screw in new ones. However, incandescent lamps give off more heat, as the greater part of the electric current is converted into heat instead of light.

It might be said here that when arc lamps are used, they should be cared for by a skilled person, whose duty alone it should be to handle them, and the work should not be done by anyone else. This will insure their proper condition, and accidents from shock will be less likely to occur. There is much greater danger from the wires for open arc lamps than from incandescent or enclosed arc circuits, the latter seldom being more than 110 to 220 volts, while the currents with the former run up to a higher voltage.

In case of shock from coming in contact with a "live wire," remember that the treatment is the same as for a drowning person. Keep up artificial respiration, give stimulants and keep up the circulation. Keep this up an hour at least, unless the patient is revived sooner.

Quantity of Light Required. The quantity of light required depends on conditions and location, thus, in the weave room or spinning room, more light is needed than in the carding room. To obtain what would be called a strong light would require about one candle-power of light for every square foot of floor space to be illuminated, while for moderate and general illumination, one candle-power to three to five square feet area would be sufficient. The mean of these would be about one candle-power for every three square feet floor space, where the reflection factor from the ceiling, shades, etc., is about 50% of the total possible efficiency.

The height of the room has considerable effect on the quantity of light required, the higher the room, the more light will there be necessary. The common practice is to allow one candle-power of illumination for from 25 to 50 cubic feet air space in the room. The cubic air space of a room is found by multiplying together its length, width and height.

The color of the walls and ceiling has a great effect on the general illumination of a room, as has been previously explained. If the walls are a dark color, it will require much more light to produce the same illuminating effect than if they were white or light colored, because most of the light falling on them is absorbed instead of being reflected. This is not so important in large spaces as in rooms of small area, for then the light is concentrated on the space under the lamps. In most mills the rooms are so large that wall-reflection is only local in effect.

The question of the color of the light used is important. The whiter the light, the greater is its illuminating power, but the redder the light the softer is its illumination and less trying it is on the eyes. The great drawback to the use of the arc light is not its brilliancy, but its excess of violet light rays. These violet rays are very harmful to the eyes, and it is

(Continued on page xvii.)

WORSTED YARNS
RICHARD CAMPION
 Selling Agent for
BRISTOL WORSTED MILLS
HIGHLAND WORSTED MILLS
THE FRENCH WORSTED CO.
 300 Chestnut Street - PHILADELPHIA

CHEMICALS AND APPARATUS
FOR THE DYE TRADE
J. & H. BERGE
 Best Bohemian Chemical Glassware and German Porcelain.
 C. P. Chemicals and Reagents, Chemists' Supplies of all kinds.
 95 JOHN STREET, - - NEW YORK

KILBURN, LINCOLN & COMPANY
LOOMS FOR
COTTON AND SILK WEAVING
 FALL RIVER, MASS.

National Prosperity
TEXTILE MANUFACTURES
 (From Latest Census Reports)

Value wool manufactures, twelve months	\$381,000,000
Value cotton goods	450,000,000
Value hosiery and knit goods	137,000,000
Value silk manufactures	133,000,000
Value Flax, hemp and jute manufactures	63,000,000
Dyeing and Finishing textiles	51,000,000
Total value textile manufactures	\$1,215,000,000

PATENT GRID WITH COMB

For Cotton Openers and Lappers

*We are prepared to sell other specialties
 for cotton mills in all Textile countries*

The ROB. SCHAELLIBAUM CO.
 288 Dyer Street, Providence, R. I.



F. G. LENTZ & CO.
Designers, Card Stampers
and Harness Builders
 FOR ALL TEXTILE FABRICS
 Mascher, Waterloo and York Sts.
 Both Phones PHILADELPHIA, PA.

SIMPLICITY

THE K-A IDEA

KIP-ARMSTRONG
COMPANY

Manufacturers of the
**K-A Electrical
 Warp Stop-Motion**
 and other

TEXTILE **ECONOMY** DEVICES

New INVENTIONS in
 Mechanical Textile Devices
 Developed and Exploited.
 Correspondence Solicited.

KIP-ARMSTRONG CO.
 Pawtucket, R.I., U.S.A.

because of this quality that the arc light causes fatigued vision and eye strain when used without opaque globes or screens.

It must be remembered that modern light sources (electric lamps, etc.) are excessively intense in brilliancy. The open arc lamp has an intensity of 10,000 to 50,000 light units to the square inch of light emitting surface, the incandescent lamps have from 200 to 300 light units per square inch, gas mantles have 20 to 25, while the standard candle gives off only 3 light units to the square inch of lighting surface. The intensity of their light makes it necessary to interpose some screen between them and the eye to prevent such lamps from injuring the vision and making it difficult to see the fine details of objects because of their glare. Naked lamps should never be used unprotected, their illumination is too intense at one point, and by contrast, too little outside of a limited area.

The said defects are entirely obviated by the use of Holophane globes around these lamps or Holophane shades over them. The very intensity of the light gives it greater illuminating effect when this light is modified and diffused over the space below the lamp by the refractive action of the Holophane prismatic glass; instead of a glaring effect we get a soft, brilliant light over a wide area.

The following comparison of the colors of various lights may be of interest. It is important when working with bright colors.

Incandescent carbon lamp gives yellowish light.

Incandescent tantalum lamp gives white light.

Enclosed arc lamp gives white light (at low voltage).

Open arc lamp gives bluish-white to violet light.

Cooper-Hewitt vapor lamp gives greenish-white light.

Moore vapor lamp has pink color, gives pinkish-white light.

Cost of Lighting. The comparative cost and the fixed cost of the lighting of a textile mill depends so largely on local conditions that no general statement can be made, in some there will be plenty of water-power available for running dynamos, in others there will be more or less power available from the steam plant, and still others will be supplied with current from outside sources, or will use gas from city mains. In cities, the cost of current may run as high as from 5 to 15 cents per kilowatt hour, when bought from companies, which amounts to about 0.6 to 0.8 cents per hour for a 16 candle-power lamp, but where electricity is cheaply generated by water-power, these figures will be much less; in fact, there is no uniformity of cost and charges.

However, a basis for comparison of the cost of lighting by any style of electric lamp, and its efficiency, may be easily arrived at by taking the average consumption of current per candle-power of each type of lamp and multiplying this by the cost of current,—this gives the efficiency of each lamp as compared to its cost for maintenance. This is the true way to estimate the value of any type of lamp, not by comparing

the first cost of the lamp itself. For instance, the ordinary 16 c. p., incandescent lamp is about one-third the first cost of the tantalum lamp, but the latter gives far more light with less current, and is therefore the cheapest when figuring on the cost of both the lamp itself and the light it gives on the same cost for electric current. The "cheap" lamp is the costliest in maintenance.

The following table of the average consumption of electric current per candle-power for the common types of lamps is given to aid in determining the cost of lighting.

Ordinary incandescent lamp	.3.1 to 3.5	watts per candle-power.				
Gem metallized filament lamp	.2.5		"	"	"	"
Tantalum filament lamp2.0		"	"	"	"
Cooper-Hewitt vapor lamp	...0.3		"	"	"	"
Bastian mercury-vapor lamp	.0.8		"	"	"	"
Enclosed arc lamp3. to 3.5		"	"	"	"
Open arc lamp3. to 3.5		"	"	"	"

It will be seen from this table that the mercury vapor lamps can be operated with the lowest consumption of power, which gives them great economical value when the cost of power is high, this being in addition to their superior efficiency in illuminating qualities. These lamps also require a low voltage current, the Cooper-Hewitt operating on a 50 to 150 volt direct current and the Bastian on a 220 volt direct or alternating. Both of these lamps and the Moore lamp have a life of about 2000 light hours.

Incandescent Lamps. Of the incandescent lamps now on the market, the tantalum lamp is by far the most efficient and the lowest in power consumption, it requiring less than two-thirds the current that an ordinary lamp does. Another point of superiority is that the tantalum lamp maintains its candle-power efficiency during use with only slight loss, losing 1% to 2% after hours of use against a loss of 15% to 20% for the carbon lamp, while this loss is accompanied by an increase of less than 1% in current required, the carbon lamp requiring 3% to 6% more current per candle-power. When a large number of lamps are used, this is an important factor, also where the cost of electric power is high. The current consumed by the tantalum lamp is less, while it gives an increase of 50% in lighting efficiency, has a longer life than the carbon lamp, (2000 hours) and gives a much better quality of light. The Gem metallized carbon filament lamp is the next in efficiency, light, etc., to the tantalum lamp.

The tantalum lamp at present costs about 2 to 3 times as much as the ordinary carbon lamp. However, it is cheaper in efficiency than a carbon lamp at all values of power cost below 4 cents per kilowatt hour, while at a power cost of 4 cents and over per kilowatt hour, it is cheaper than even metallized filament lamps. This considers cost of renewals of lamps, cost of current per candle-power, actual efficiency, maintenance, etc.

(To be continued)

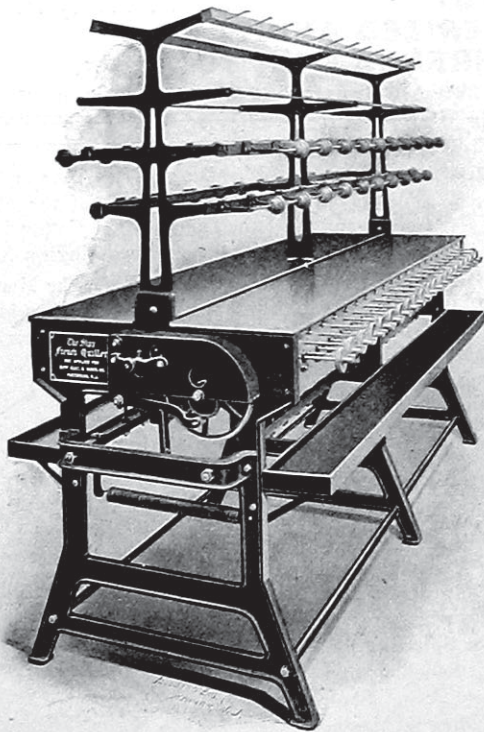

The Sipp Improved French Quiller

The QUILLER that Will Produce More
GOOD QUILLS
IN LESS TIME

Than Any Other QUILLER Made

Prices and Circulars on Application to

THE
Sipp Electric and Machine
Company

Keen and Warren Streets and Erie R. R.
 PATERSON, N. J.

WEIMAR BROTHERS
 MANUFACTURERS OF
Tapes, Bindings and Narrow Fabrics
 2046-48 AMBER STREET
 PHILADELPHIA

WHEN QUALITY COUNTS WE GET THE ORDER



Cuts in this Journal are a sample of our work.

WANTED A small cotton mill
 that can be bought rea-
 sonably, or any small mill that needs
 a little capital. Address: W. R. M.,
 Care of POSSELT'S TEXTILE JOURNAL.

Cost and Accounting Systems
Periodical or Casual Audits

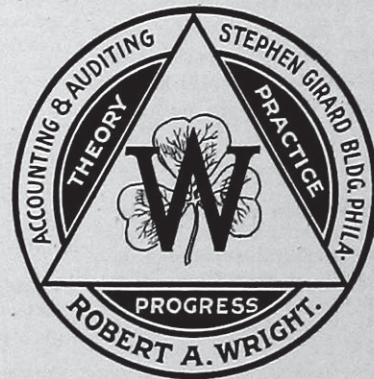

Consultations and
General Accounting

THEODORE H. STROUSE & CO. 426-428 MARKET STREET, PHILADELPHIA, PA. COTTON YARNS, MERCERIZED AND PLAIN. FINE SINGLE, TWO AND THREE PLY UP TO 200's.

Sole American Agents for Messrs. Wm. A. Holt, Ltd., Cotton Spinners and Doublers, Bolton, England.

Superintendent or Assistant Superintendent and Designer. 22 years experience on Woolen and Worsteds, here, Canada and in Scotland. Holds certificates from The City and Guild of London, and the Galashiels Manufacturers Corporation (1902). R. L. 10, POSSELT'S TEXTILE JOURNAL.

Superintendent for Knitting Mill in Georgia. To take charge of 100 Latch needle machines on Women's and Children's Ribbed Underwear (Cotton). We require a man who can manage machines, material and help to best advantage. Address only with full particulars: C. K. Co. 12, POSSELT'S TEXTILE JOURNAL.

Boss Finisher. Have had thirty years experience as a textile finisher. Understand dry finishing of woolen goods, and all classes of cotton goods from loom to case. Also cotton bleaching, knit goods, piece goods, skeins and warps. Am a good manager of help, can manage any department in finishing or superintend cotton bleaching and finishing works. J. H. 11, POSSELT'S TEXTILE JOURNAL.

Boss Weaver with 6 years' experience in Philadelphia mills, would like position in New England, Rhode Island preferred. Best of references. L. S., POSSELT'S TEXTILE JOURNAL.

Boss Weaver, 10 years' experience in a prominent Maine Woolen Mill and 2 years in Philadelphia, wants position, no objection to go West. S. H., POSSELT'S TEXTILE JOURNAL.

Designer for Woolen and Worsteds, Graduate from Posselt's Textile School, with two years' practical experience in New England mills, is open for position either as designer or assistant to superintendent. H. B., POSSELT'S TEXTILE JOURNAL.

Boss Dyer, 3 years' experience as overseer on wool, yarn, piece-goods and mixes. Age 25, German, best of references. S. K., POSSELT'S TEXTILE JOURNAL.

For Sale. Scale (Troemner), agate bearings, dust-proof case, never been used, cost \$35; also a practically new Microscope (Zentmayer), cost \$75. Address: Student, care of JOURNAL.

Boss Dyer. Seven years' experience in Hardening, Fulling, Washing and Dyeing Woolen Felts. Temperate and steady. Go anywhere, prefer the South. G. H. 13, POSSELT'S TEXTILE JOURNAL.

Designer or Assistant. Experienced on all kinds of cloths, narrow and broad work. Philadelphia preferred. 29 years of age, married. P. H. C. 14, POSSELT'S TEXTILE JOURNAL.

Asst. Designer or Boss Weaver. Extensive experience on Fancy Worsteds and Woolens, also on Cotton Worsteds. 32 years of age, single. T. F. L. 15, POSSELT'S TEXTILE JOURNAL.

Overseer of Carding or Spinning, including Ring Spinning, Spooling and Warping, or both; or Asst. Supt. Thorough Mechanic, holding a Massachusetts Engineer's License; also understand finishing and warp preparation as well as the construction of plain and dobby looms, having repaired and set them up. Learned all to take Superintendent position. Am at present employed as Spinner in charge of 11,000 spindles; was second hand in Card room previous to spinning. Well up on Waste-question. Have always raised the production where employed. Strictly temperate, American, married and best of references. Go anywhere. W. R. H. 16, POSSELT'S TEXTILE JOURNAL.

MILL NEWS

Philadelphia. Construction of the new mill for the Berkshire Hosiery Mills of Wyomissing has been completed and the machinery is now being installed.

Camden, N. J. The Franklin Narrow Fabric Company has been incorporated with a capital of \$50,000.

Salem, N. Y. The Marble Knitting Mill Company has been formed with a capital stock of \$60,000.

Waterloo, N. Y. The Waterloo woolen mills, which have been closed since last October, have reopened with a nearly full quota of employees.

Syracuse, N. Y. The Oak Knitting Company has been incorporated, capitalized at \$50,000.

Woodbury, Md. After an idleness of several weeks two of the mills owned by the Consolidated Cotton Duck Company are again working on full time.

Woonsocket, R. I. The Manville Company have started the 1,000 looms in the Social Mill, which had been idle since February 20.

Bristol, Conn. Birge & Sons Company are operating some of their departments thirteen hours a day, having enough contracts on hand to insure running this way for months. They employ about 200 hands.

Central Village, Conn. Construction work on the new addition to the Central Worsted Company's plant will begin as soon as the weather permits. The company has increased its capital stock from \$50,000 to \$75,000.

Torrington, Conn. The Warrenton Woolen Company has perfected plans for a new factory building, a two-story brick affair, 80 by 300 feet. The company will also construct new wool building, dye house and boiler house, all of brick.

Lawrence, Mass. The entire plant of the Everett Mills has started on full time.

East Glastonbury, Conn. The Angus Park Mfg. Co., who make a specialty of ladies' suitings, are working on overtime schedule and will continue to do so for some time to come.

Exeter, N. H. The mills of the Exeter Manufacturing Company have resumed work on full time. About 400 hands are affected.

Sangerville, Me. The Sangerville Woolen Company has been organized for the manufacture of woolen, cotton and worsted cloths, etc., with \$50,000 capital stock, all of which is paid in.

Charlotte, N. C. The incorporators of the Chadwick-Hoskins Manufacturing Company, with an authorized capital stock of \$3,000,000, have formally organized. The fixed capital is placed at \$1,000,000 and the preferred stock at \$800,000. Officers elected were: E. A. Smith, president; Gen. William F. Draper, of Hopedale, Mass., vice-president; E. C. Dwelle, secretary, and Arthur J. Draper, treasurer. The regular meeting of the stockholders will be held the last week in March at the office of the company on South Church St.



We are
prepared
to prove that
Peroxide of
Sodium for

Bleaching
animal & vegetable
fibres
or their mixtures
is the best.
Rosessler & Hasselbacher
Chemical Co.
New York

Biddeford, Me. The cotton mills of the Pepperell and of the York Manufacturing Company went back on full time, benefiting about 6,000 operatives.

Bristol, Va. Edward P. Jones has leased a building, and is now installing 31 knitting machines, ribbers, loopers, dryer and embroidering machines; about 70 operatives will be employed.

Weldon, N. C. Preliminary work on the construction of the buildings for the Shaw Cotton Mills has been started.

Flat Rock, N. C. The Trident Hosiery Mills has been organized with a capital stock of \$15,000.

Alexander City, Ala. The spinning plant of the Russell Manufacturing Company has begun operations with 2,736 spindles, producing 24s yarns, most of which are taken by the company's knitting plant, which has a daily capacity of 1,000 dozen ladies' vests.

Atlanta, Ga. Demands for the product of the Atlanta Woolen Mills have made it necessary to employ day and night shifts indefinitely. The mills manufacture cotton-mixed and all-wool jeans, fancy cassimeres, etc.

Albany, Ga. It is rumored that Mr. Smith D. Pickett will organize a company to build a cotton mill of 10,000 spindles, the mill to be driven by electricity.

Cedartown, Ga. The Southern Hosiery Mills, \$20,000 capital, has secured suitable buildings and will install machinery for knitting half-hose with a daily capacity of 250 dozen pairs.

Loudon, Tenn. The Loudon Hosiery Mills will double their output, the present equipment being 30 knitting machines, dyeing plant, etc.

Lebanon, Tenn. The people here are agitating now the erection of a woolen mill. Dr. H. K. Edgerton is at the head of the movement.

Sedalia, Mo. A large mill is to be built here by the Sedalia Woolen Mill Co. to replace the one burned in December.

Los Angeles, Cal. Plans have been filed for a \$400,000 cotton mill to make staple goods. The plant will cover about three acres of land.

Alexander City, Ala. The new mill of the Russell Manufacturing Company is about completed at an estimated cost of \$100,000. The equipment will consist of 2,700 spindles and the daily production will be about 6,000 pounds of yarn.

Davidson, N. C. It is reported that work on the erection of the mill buildings of the Delburg Cotton Mills has begun. The size of the plant will be 2,500 spindles and the output 12's to 20's yarn.

Covington, Ga. It is reported that the Covington Mills, Mr. O. S. Porter, Agt., are to add a complete thousand spindle equipment to their mills.

Ludlow, Vt. The industrial depression felt in this vicinity since the first of the year because of the closing of seven mills is somewhat lightened by the resumption of operations on half-time at the Black River Woolen Mill, giving about 100 hands an opportunity to work again.

Bridgeport, Conn. The Salts Textile Company is running its plant on fifty-seven hours a week time, which is an increase in the schedule.

Philadelphia, Pa. John Dobson's blanket and cloth mill at Manayunk, which has been shut down since the early part of last autumn, has been started again.

Simpsonville, S. C. A cotton mill of considerable capacity and to manufacture a staple line of goods, it is rumored, has been organized here. E. F. Woodside, who is also connected with other mills, has been elected president of the company.

Waupaca, Wis. The Waupaca Felting Mills, which closed during the financial flurry on account of the canceling of orders, recommenced operations March 4th.



"HURRICANE" DRYERS

For Wool, Cotton Stock, Yarn, Knit Goods, Etc.

Belt-Driven **FANS** Motor-Driven

Power Screw **PRESSES** Hydraulic

WRITE FOR CATALOGUES

THE PHILADELPHIA DRYING MACHINERY CO.,
6721 GERMANTOWN AVE., PHILADELPHIA, PA.

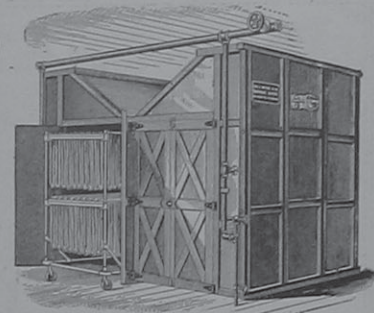

Boston. Providence. Philadelphia. Chicago. Charlotte. Albany. Toronto, Can.

FARBENFABRIKEN OF ELBERFELD CO.,

IMPORTERS OF ANILINE & ALIZARINE COLORS

P. O. Box 2162

NEW YORK

66 Lafayette Street

AMERICAN TEXTILE SPECIALTY MACHINERY CO.

MANUFACTURERS OF

Shuttles and Shuttle Irons for all Textile Purposes

NEVER-SLIP COP SPINDLES AND TUBES

N. Y. Office, 363-373 Rider Ave.

670 Eddy St., PROVIDENCE, R. I.

A New Way of Designing Counterpanes or Bedspreads.

In this new way of designing counterpanes or bedspreads, the design is so woven in that the fabric can be used either in the usual rectangular shape, or with two corners cut therefrom, to provide depending flaps. The accompanying illustration represents a plan view of a counterpane or bedspread with the design woven in this manner.

In completed form, the article produced represents a fabric section of desired length and width, in which is woven a design including a main design outline of such contour as to leave square or approximately square corner portions of the fabric section beyond the main design outline. There is, therefore, included within this main design outline, a central section, corresponding in outline to the outline of the fabric section and having side and end flaps of approximately equal width and lengths respectively to the similar dimensions of the central section. The central section is woven with a design complete in itself, and the flap sections are woven with designs corresponding to each other, so that when the free edges of the flaps are arranged in juxtaposition, the flap design will be unbroken and the continuity of effect preserved.

The fabric woven as described, may if desired be used as an entirety for the bedspread, or it may be cut along the main design outline to produce a cut-corner bedspread, or it may be cut along portions of the main design outline and the auxiliary design outline, producing a bedspread conforming in contour to

that of the fabric section, though of slightly less dimensions. After severing the bedspread, to produce an article of either form noted, the design outline will,



of course, form the edge boundary of the article, the same to be embroidered in white or colored thread. This procedure of designing counterpanes or bedspreads is the invention of Mr. C. L. Christmann.

"Textile Designing Simplified."

The object of this chart is to show how easy weaves for all classes of Textile Fabrics can be constructed; it will be a search light in the misty matters in the field of designing Textile Fabrics. Keep this chart of weaves for reference. Millions of new weaves can be obtained by it.

All weaves for Textile Fabrics have their foundation in Plain Twills and Satins.

PLAIN.—This weave and its sub-divisions are explained on the chart in the top row by 16 weaves, the sub-divisions covering common, fancy and figured Rib and Basket weaves.

TWILLS.—The foundation of constructing regular (45°) twills is shown by rows 2 and 3 with twenty six weaves, covering twill weaves all the way from 3 harness up to 13 harness. The sub-divisions of twills are quoted next on the chart, being Broken twills, Skip twills, Corkscrews, Double twills, Drafting twills, Curved twills, Combination twills warp drafting, Combination twills filling drafting, 63° twills, 70° twills, Wide wale twills, Entwining twills, Checker-board twills, Pointed twills, Fancy twills, thus covering every sub-division of twill weaves possible to be made.

SATINS are next shown, giving also their sub-divisions, viz: Double satins and Granites.

HOW TO PUT A BACK FILLING ON SINGLE CLOTH is shown below the satins by two examples, and at its right hand is quoted the principle of HOW TO PUT A BACK WARP ON SINGLE CLOTH.

On the bottom line are given the four steps for:—

THE CONSTRUCTION OF DOUBLE CLOTH, 2 @ 1; and above the same one example, with the arrangement 1 @ 1.

THREE PLY CLOTH is shown by one example.

HOW TO BACK SINGLE CLOTH WITH ITS OWN WARP is shown by two examples.

WEAVES FOR SPECIAL FABRICS are quoted: Tricots (warp, filling and Jersey effects), Rib fabrics, Honeycombs, Imitation Gauze, Velveteen, Corduroy, Chinchillas, Quilts, Plush, Double-plush, Tapestry, Crape, Terry, Worsted coating stitching, Huckas, and Bedford cords.

HOW TO WORK THIS CHART OF WEAVES.

CAPITAL LETTERS of references refer to the plain weave and its sub-divisions.

SMALL LETTERS of references refer to twills and their sub-divisions.

NUMERALS of references refer to satins and their sub-divisions.

Example.—How to ascertain the construction of the weave at the right hand top corner of the chart; being the figured rib weave marked C C? These two letters of reference mean that said figured rib weave is nothing else but the combination of the 2-harness 6 picks common rib weave warp effect C, and the 6 harness 2 picks common rib weave filling effect C'.

Example.—The letter of reference *c*, underneath the first broken twill indicates that the same is obtained from the $\frac{1}{2}$ 4 harness twill *c*, (third weave on the second row; in other words, letter of references below each weave of any of the various sub-divisions refer always to the corresponding foundation weave.

Example.—Twill *q* and *o*, are the foundation for the eight combination twills filling drafting, said common twills are drafted 1 @ 1, the different designs being obtained by means of different starting.

Example.—The wide wale twill *l' w'*, has for its foundation the 63° twills, marked also respectively *l'* and *w'*, the latter two weaves have again for their foundation respectively the common twills marked *l* and *w*.

Example.—Granites marked 8 have for their foundation the 8-leaf satin, such as marked 12 the 12-leaf satin.

Example.—Backed by filling *e* 8, means the common $\frac{2}{2}$ 4-harness twill *e*, (fifth weave on second row) and the 8-leaf satin is used in the construction of this weave.

Example.—The complete design of double cloth, marked *e* 8 A, means that the common $\frac{2}{2}$ 4-harness twill (*e*), the common plain (A) and the 8-leaf satin (8) are used in the construction.

Example.—Rib fabric A, indicates that the plain weave forms the foundation.

It will be easy to substitute different foundations in constructing weaves for heavy weights. In reference to single cloth weaves we only want to indicate that by following rules shown in the chart, millions of new weaves can be made up from it.

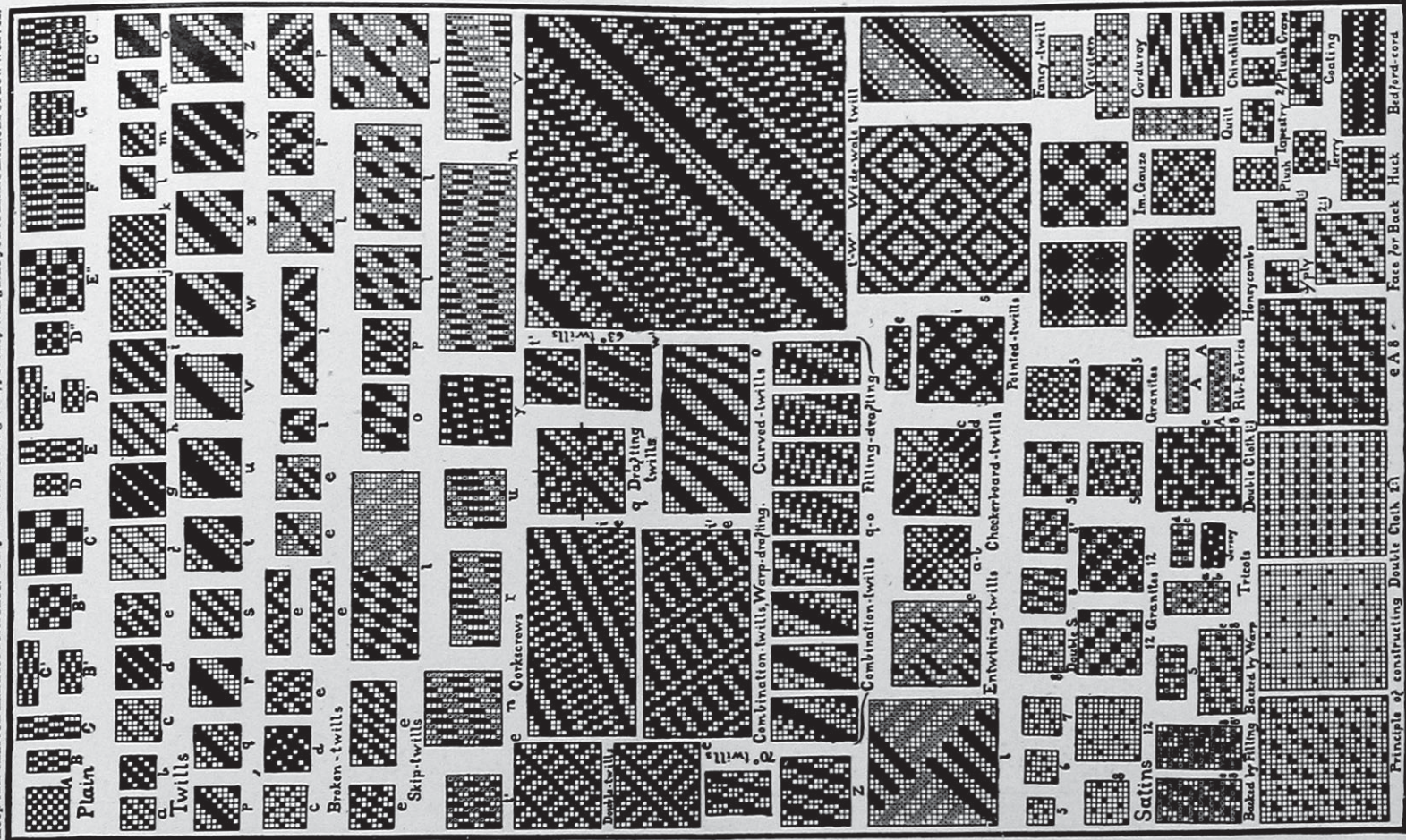

LOOMS

FOR WOOLENS, COTTON, SILKS
AND ALL SPECIAL FABRICS
DOBBIES, JACQUARDS, WOOL COMBS
PRINTING DRUMS, REPAIR PARTS and SUPPLIES

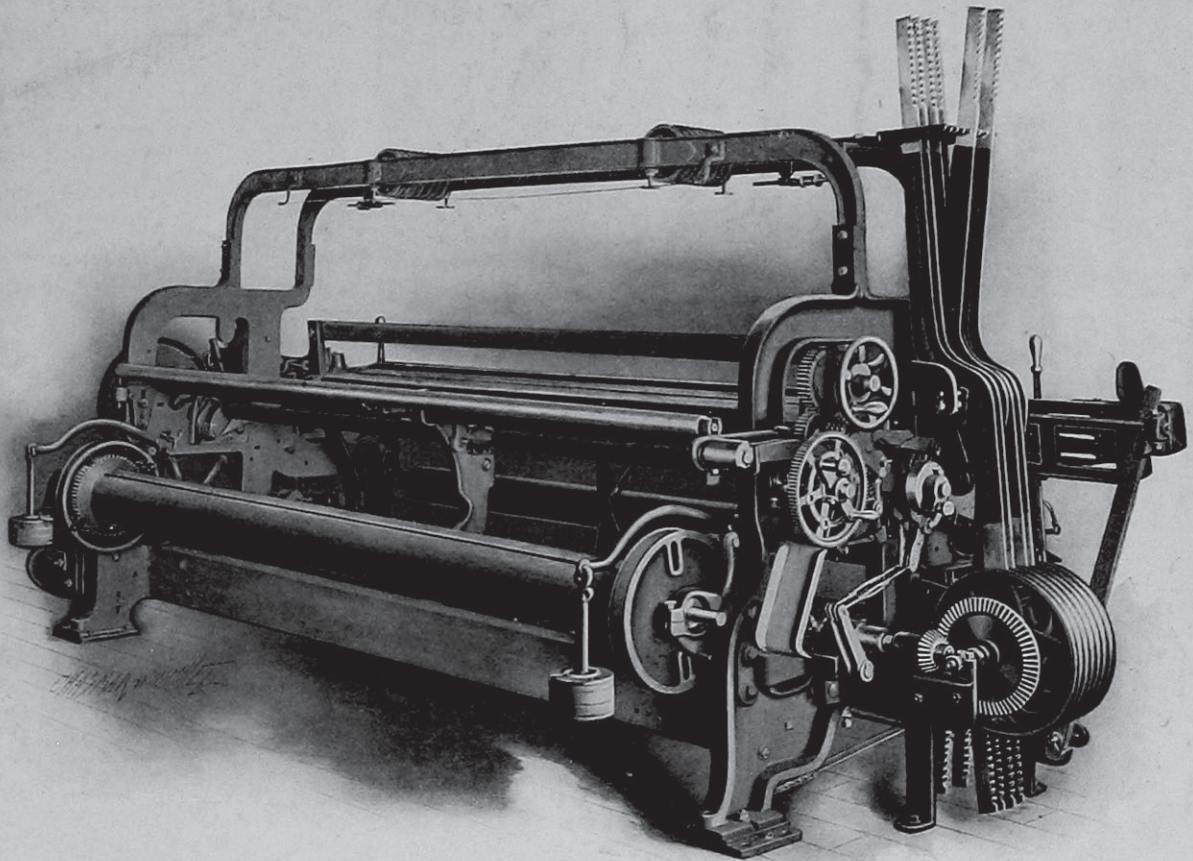

CROMPTON & KNOWLES LOOM WORKS

WORCESTER, MASS. PROVIDENCE, R. I. PHILADELPHIA, PA.

Southern Representatives—ALEXANDER & GARSED, Charlotte, N. C.

Foreign Representatives—HUTCHINSON, HOLLINGWORTH & CO., Ltd., Dabcross, England