

Posselt's Textile Journal

A Monthly Journal of the Textile Industries

Table of Contents

A New Knitting Machine for the Manufacture of Neckties.....	289
Improvement to the Take Up for Circular Knitting Machines.....	291
The Bleaching, Dyeing and Finishing of Knit Goods.....	292
Full Fashioned Hosiery.....	296
A Reinforced Stocking.....	303
Improvement to Knitting Needles.....	304
A New, Quick Motion Flat Rib Top Machine.....	305
A Study of Knitting.....	307
Designing and Fabric Structure for Harness Work.....	310
A Practical Treatise on the Knowles Fancy Worsted Loom.....	311
Ribbons, Trimmings, Edgings, Etc.....	312
Jacquard Designing.....	315
Dictionary of Technical Terms Relating to the Textile Industry.....	316
Silk From Fibre to Fabric.....	318
A New Silk Throwster's Spindle.....	319
The "Mason" Coiler Drawing Frame.....	320
Cotton Spinning.....	321
Workers, Strippers, Fancy and Swift.....	323
Producing High Counts in the Spinning of Woolen Yarns.....	324
To Impart a Permanent Finish.....	324
The Importance of Proper Boiling of Starches.....	325
Apparatus for Dyeing or Printing Yarns and Fabrics.....	326
New Designs for Textile Fabrics.....	326
Some Special Cotton Finishes.....	326
Cotton From Field to Factory.....	xii
Buyer's Index.....	vi
Mill News.....	xvi

COPYRIGHTED 1908
By E. A. POSSELT

Entered as second-class matter February 10, 1908, at the post office at Philadelphia, Pa., under the Act of Congress of March 3, 1879.

E. A. Posselt, Publisher, 2028 Berks St., Philadelphia, Pa.

European Agents: Sampson Low, Marston & Co., Ltd., 100 Southwark Street, London, S. E.

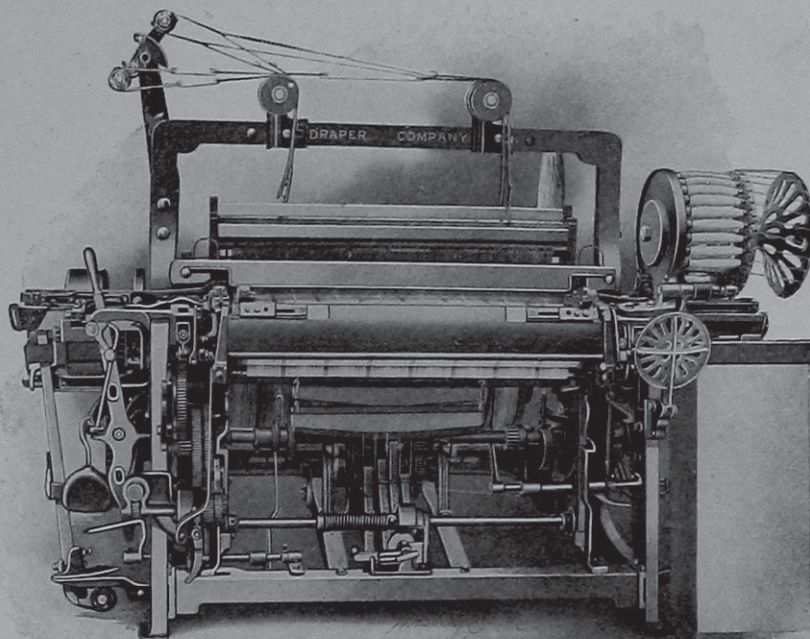

This is the Well Known E Model

NORTHROP LOOM

IN ITS LATEST REVISED CONSTRUCTION

If interested in this or any other models
of automatic filling-changing looms,

write to

**DRAPER COMPANY,
HOPEDALE, - MASSACHUSETTS**

Southern Agent **J. D. CLOUDMAN**, 40 South Forsyth St., ATLANTA, GA.

POSSELT'S
TEXTILE JOURNAL

A PRACTICAL AND
EDUCATIONAL JOURNAL

DEVOTED TO
THE TEXTILE INDUSTRIES.

2028 BERKS STREET,
PHILADELPHIA, PA.

THE WHITIN MACHINE WORKS

WHITINSVILLE, MASS.

BUILDERS OF

COTTON MACHINERY

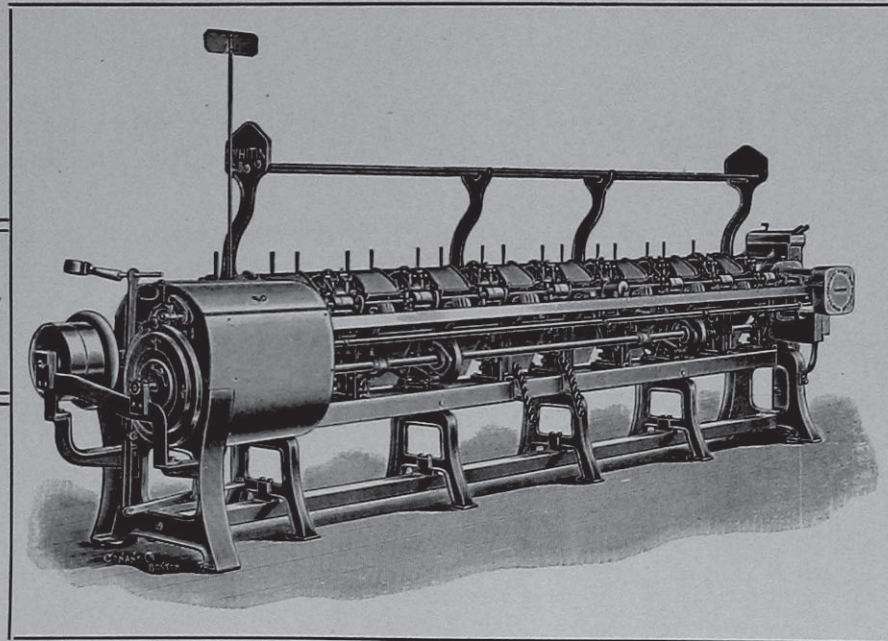

High-Speed

Comber

CARDS, COMBERS, DRAWING FRAMES, SPINNING FRAMES, SPOOLERS

TWISTERS, REELS, LONG CHAIN QUILLERS,
LOOMS

SOUTHERN AGENT

STUART W. CRAMER

CHARLOTTE, N. C., and ATLANTA, GA.

The METALLIC DRAWING ROLL CO.

SOLE MANUFACTURERS OF

Patent Metallic Rolls

For Fibrous Materials

*33 Per Cent. More
Production Guaranteed,
at Less Cost*

WRITE FOR PRICES AND
PARTICULARS

Applied to any make of machine,
new or old, and successfully on the
following Carding Room Machinery:

**Sliver Lap Machines;
Ribbon Lap Machines;
Comber Draw Box; Rail-
way Heads; Drawing
Frames, with Electric or
Mechanical Stop Motion;
Slubbers; Intermediate
Frames.**

THE METALLIC DRAWING ROLL CO.,

INDIAN ORCHARD, MASS.

ALWAYS DEPENDABLE

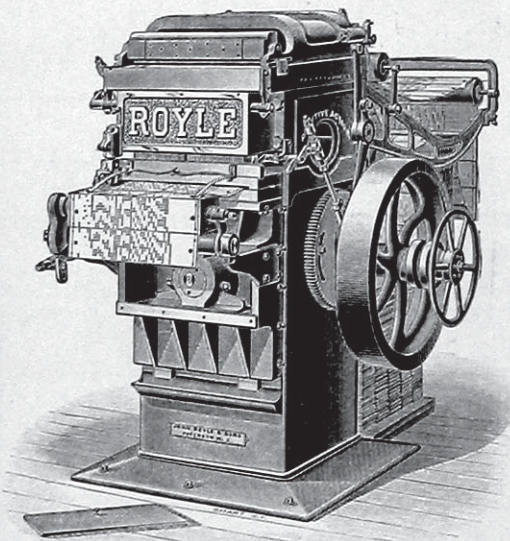

AUTOMATIC REPEATER

A recent mail brought in this testimonial—

**“We Have Much Faith in
the Machines You Build.”**

This confidence had been expressed in
a most substantial form previously by an order
for one of our Repeaters and Automatic
Lacing Machines.

Are You Interested?

Write for catalogue on
Jacquard Card-Cutting Machinery.

**John Royle & Sons,
PATERSON, N. J., U. S. A.**

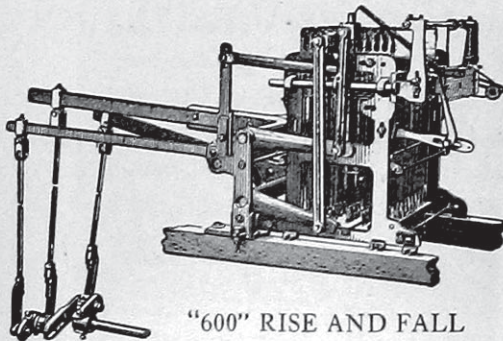

“600” RISE AND FALL

“The HALTON JACQUARD”

For Fabrics of Every Description
HARNESS BUILDING

THOMAS HALTON'S SONS
Allegheny Avenue and C Street, Philadelphia

MASON MACHINE WORKS

... TAUNTON, MASS. ...

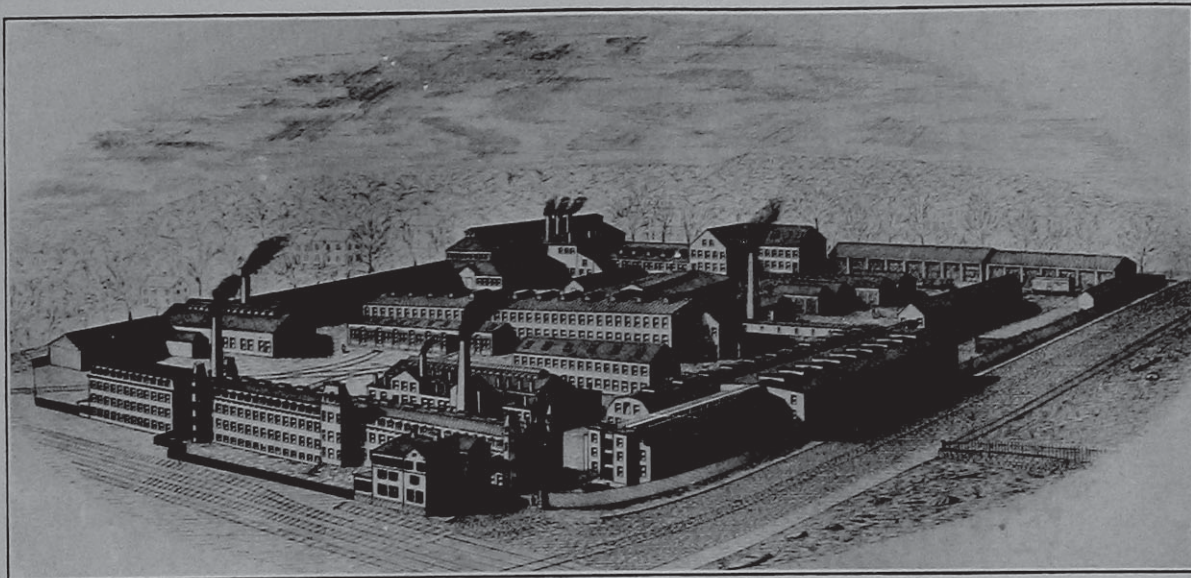

BUILDERS OF
COTTON MILL MACHINERY

*To the Members of the National Association of Hosiery
Manufacturers and American Knit Goods Manu-
facturers' Association and their Friends:*

You are cordially invited to make use of our facilities during the Convention and Exhibition at "Space 15" in the Exhibition Hall.

We would ask you to come along and become acquainted with **Posselt's Textile Journal** and its workers, who are striving to give the Knit Goods and Hosiery Trade **the right thing in the right line.**

Both, Mr. E. A. Hoyt, formerly Associate Editor of the *Textile Record*, and Mr. H. Nelson Craig, the Philadelphia Representative, will be glad to entertain you and make things interesting as well as profitable.

Mr. E. A. Posselt, the Editor and Publisher, who needs no introduction to the Hosiery and Knit Goods Trade, will also be there to welcome you.



MODEL D
WOOL WASHER

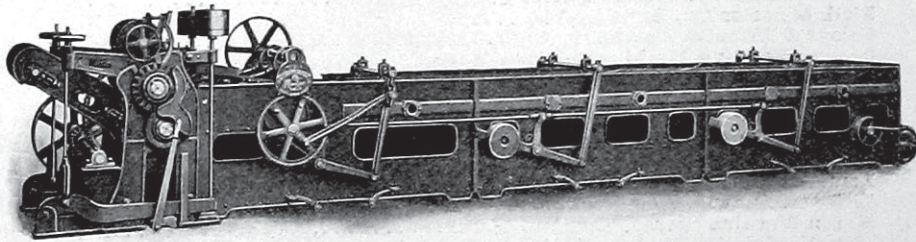

Not "A Has Been." Not "A Going To Be"
 but a present day success.
 Parallel Rake—Large Settling Bowl.
 Self Contained Flushing Appliance.
 ASK FOR BULLETIN No. 54.

CHENEY BROTHERS

SILK MANUFACTURERS
SOUTH MANCHESTER, CONNECTICUT

SALESROOMS:

NEW YORK, 477 Broome Street BOSTON, 78 Chauncy Street
 CHICAGO, Heyworth Building PHILADELPHIA, 929 Chestnut Street
 SAN FRANCISCO, CAL., 1239 Franklin Street

ALL KINDS OF

Spun Silk Yarns

In the Gray, Dyed or Printed

ALL KINDS OF

ORGANZINES, TRAMS and SINGLES

In the Gum or Dyed, on Spools or on Cones, Warped or in the Hank.

16 OUNCES TO THE POUND PURE SILK

FAST COLORS WARRANTED

SPECIAL YARNS made to order for all sorts of SILKS or SILK MIXTURE GOODS.

MANUFACTURERS' ORDERS PROMPTLY EXECUTED

ALL KINDS OF

Knitting Silks, Ribbons and Piece Silks Used for Trimming Knit Goods

LIST OF ADVERTISERS

Altemus, Jacob K., Philadelphia.....	XV
American Textile Specialty Machinery Co., Providence, R. I.....	XVI
Berge, J. & H., New York.....	XI
Brinton, H., Co., Philadelphia.....	VIII
Campion, Richard, Philadelphia.....	XI
Chapin, Geo. W., Philadelphia.....	IX
Cheney Brothers, South Manchester, Conn.....	V
Commercial Photo-Engraving Co., Philadelphia.....	XIII
Crompton & Knowles Loom Works, Worcester, Mass.....	Outside back cover
Cumming, J. W., Clonliffe, Dublin.....	X
Draper Company, Hopedale, Mass.....	Inside front cover
Farbenfabriken of Elberfeld Co., New York.....	XVI
Firth & Foster Co., Philadelphia.....	IX
Griswold Worsted Co., Darby, Pa.....	XIV
Grosser Knitting Machine Co., New York.....	VII
Halton's, Thomas, Sons, Philadelphia.....	III
Howard Brothers Mfg. Co., Worcester, Mass.....	IX
Hunter, James, Machine Co., North Adams, Mass.....	V
Kilburn, Lincoln & Co., Fall River, Mass.....	XI
Kip-Armstrong Company, Pawtucket, R. I.....	XI
Lentz, F. G., & Co., Philadelphia.....	XI
Littauer, Ludwig, New York.....	IX
Mason Machine Works, Taunton, Mass.....	IV
Metallic Drawing Roll Co., Indian Orchard, Mass.....	III
New England Butt Co., Providence, R. I.....	XVI
Nydegger, Max, New York.....	VI
Philadelphia Drying Machinery Co., The, Philadelphia.....	XVI
Queensbury Mills, Worcester, Mass.....	IX
Roessler & Hasslacher Chemical Co., New York.....	XV
Royle, John, & Sons, Paterson, N. J.....	III
Ryle, William, & Co., New York.....	IX
Schaellibaum, Rob., Co., The, Providence, R. I.....	XI
Schlatter, Karl, Dye Works, Philadelphia.....	XIII
Schuchardt and Schütte, New York.....	XIII
Sipp Electric & Machine Co., Paterson, N. J.....	XIII
Spindler, E. O., New York.....	X
Strouse, Theodore & Co., Philadelphia.....	XIV
Textile Publishing Co., Philadelphia.....	XI
Weimar Bros., Philadelphia.....	XIII
West Indies Chemical Works, The, New York.....	IX
Whitaker Reed Co., Worcester, Mass.....	XIII
Whitin Machine Works, The, Whitinsville, Mass.....	II
Wright, Robert A., Philadelphia.....	XIII

BUYERS' INDEX

Apparatus for the Dye Trade.

Berge, J. & H.

Automatic Feeds for Cotton and Wool Stock.

Philadelphia Drying Machinery Co.

Bleachers.

Firth & Foster Co.

Bleaching Kiers.

Philadelphia Drying Machinery Co.

Bleaching Materials.

Roessler & Hasslacher Chemical Co.

Bobblins.

Draper Co.

Braiding Machinery.

New England Butt Co.

Carbonizing Machinery.

Hunter, James, Machine Co.
Philadelphia Drying Machinery Co.

Card Clothing.

Howard Bros. Mfg. Co.

Card Stampers.

Lentz, F. G. & Co.

Carpet Machinery.

Altemus, Jacob K.
Philadelphia Drying Machinery Co.

Chemicals.

Berge, J. & H.
Roessler & Hasslacher Chemical Co.
West Indies Chemical Works, Ltd.

Chroming Machinery.

Philadelphia Drying Machinery Co.

Cost and Accounting Systems.

Wright, R. A.

Cotton Combers.

Mason Machine Works.
Whitin Machine Works.

Cotton Machinery.

Altemus, Jacob K.
Crompton & Knowles Loom Works.
Draper Co.
Halton's, Thomas, Sons.
Kip-Armstrong Co.
Mason Machine Works.
Metallic Drawing Roll Co., The.
Philadelphia Drying Machinery Co.
Schaellibaum, Rob., Co., The.
Whitin Machine Works.

Cotton Yarns.

Chapin, George W.
Littauer, Ludwig.
Strouse, Theodore & Co.

Designers.

Lentz, F. G. & Co.

Design Paper.

Textile Publishing Co.

Drawing Frames.

Mason Machine Works.
Whitin Machine Works.

Drying Machinery.

Hunter, James, Machine Co.
Philadelphia Drying Machinery Co.

Dust Collectors.

Philadelphia Drying Machinery Co.

Dyers & Finishers.

Firth & Foster Co.
Schlatter, Karl, Dye Works.

Dyeing, Drying, Bleaching and Finishing Machinery.

Hunter, James, Machine Co.
Philadelphia Drying Machinery Co.
Schuchardt and Schütte.

Dye Sticks.

Philadelphia Drying Machinery Co.

Dyestuffs.

Farbenfabriken of Elberfeld Co.

Dynamos & Motors.

Sipp Electric & Machine Co.

Electric Fans.

Philadelphia Drying Machinery Co.

Engravers.

Commercial Photo-Engraving Co.

Grids for Lappers.

Schaellibaum, Rob., Co., The.

Harness Builders.

Crompton & Knowles Loom Works.
Halton's, Thomas, Sons.
Lentz, F. G. & Co.

Harness Twine.

Littauer, Ludwig.

Heating and Ventilating Apparatus.

Philadelphia Drying Machinery Co.

Heddles.

Howard Brothers Mfg. Co.
Whitaker Reed Co.

Hematine.

West Indies Chemical Works, Ltd.

Jacquards.

Crompton & Knowles Loom Works.
Halton's, Thomas, Sons.

Jacquard Card Stamping, Lacing and Repeating Machinery.

Royle, John & Sons.

Knitting Machinery.

Brinton, H., Co.
Grosser Knitting Machine Co.
Spindler, E. O.

THE
**Grosser
Knitting
Machine
Company**

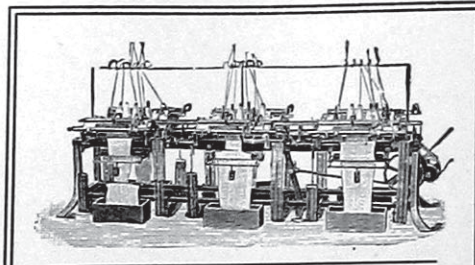

MAX NYDEGGER
260 West Broadway, -- NEW YORK

⊕
Exclusive Agent
for the Best
Foreign Machine
Manufacturers



REPRESENTING

C. F. GROSSER, Markersdorf, Bez. Leipzig: Manufacturer of all kinds of flat *Latch Needle Knitting Machines*, Lamb style, to be operated by hand or automatically run by power. *Best machines for manufacturing Jackets, Coats, Sweaters, Underwear, Fancy Knit Goods* in all styles, *Gloves, Stockings, Shaker Goods, Sporting articles, Jerseys, etc.* Spoolers and Winders especially adapted for Hosiery and Knit Goods Factories.

C. HILSCHER, Chemnitz: Manufacturer of "Cotton Hilscher" Machines for *fine gauge full fashioned Hosiery, Jerseys and Underwear*, Rip Top Frames "Cotton and Hilscher" style.

WILH. BARFUSS, Apolda: Manufacturer of WARP KNITTING machinery, double Rib Frames, etc., for all the *fancy articles, Shawls, Hoods, Caps, Fascinators, etc.* *Glove fabric* in Silk, Cotton and Worsted, *Lace Gloves, etc.*

C. TERROT SOEHNE, Cannstatt - Stuttgart: Manufacturer of French Circular Frames, producing *finest Balbriggan for Underwear, Fancy stitches, Lace work "Ponos Knit."* Machines for using Hard Worsted or Lisle, Yarns, Silk, etc.

JULIUS KOEHLER, Limbach: Manufacturer of the "DIAMOND" *Overseamer* for all selvedged articles as Full Fashioned Hosiery, Underwear and other knit articles. LOOPERS, producing finest elastic and flat seam. If you make Hosiery or Underwear YOU cannot be without it.

BEST GERMAN LATCH BEARD NEEDLES. *Quality is the money saver.* If you want anything in Knitting Machines, etc., write to me. My long experience in the Knitting line is yours for the asking. Information and samples supplied upon application.

The attention of Visitors to the Exhibition held by THE NATIONAL ASSOCIATION OF HOSIERY MANUFACTURERS from May 11th to May 16th at 809 Chestnut Street, Philadelphia, ought to be specially directed to the

**NEW LARGE DIAL (16 in. Diam.)
GERMAN LOOPER**

Built by JULIUS KOEHLER, LIMBACH and Exclusively Sold by
THE GROSSER KNITTING MACHINE CO.

MAX NYDEGGER
260 West Broadway - - - - - NEW YORK CITY

It is the Looper that Loops and does it well. You are cordially invited to investigate the matter. Samples and specifications are at your disposition for the asking.

"THOSE FROM MISSOURI" will please bring some Hosiery or Underwear with them to have the same looped in their presence by experienced operators. Thus you can investigate the matter thoroughly, state your needs and wishes. This is the machine that will do the work and does it well; I am here to prove my statements. For particulars, quotations and samples by mail, apply at New York Headquarters.

Posselt's Textile Journal

Vol. II.

May, 1908.

No. 5.

A New Knitting Machine for the Manufacture of Neckties.

This is the latest novelty in knitting machinery brought in the market by Philadelphia's foremost builders of knitting machinery, the Messrs. H. Brinton & Co. Its product will revolutionize the manufacture of Neckties, both for men and women, during seasons to come on account of the superior character of construction of these fabrics over regular woven goods; again, they present a chance for Novelties impossible to be obtained otherwise. Although these knitting

The new machine made its first appearance in November last year and since that time improvements have been constantly added, making the machine, considered as a whole, more universal. The machine is what is known technically as a *full automatic machine*.

A most suitable material for this class of fabrics is Artificial Silk, both on account of its pronounced lustre as well as body of the fibre.

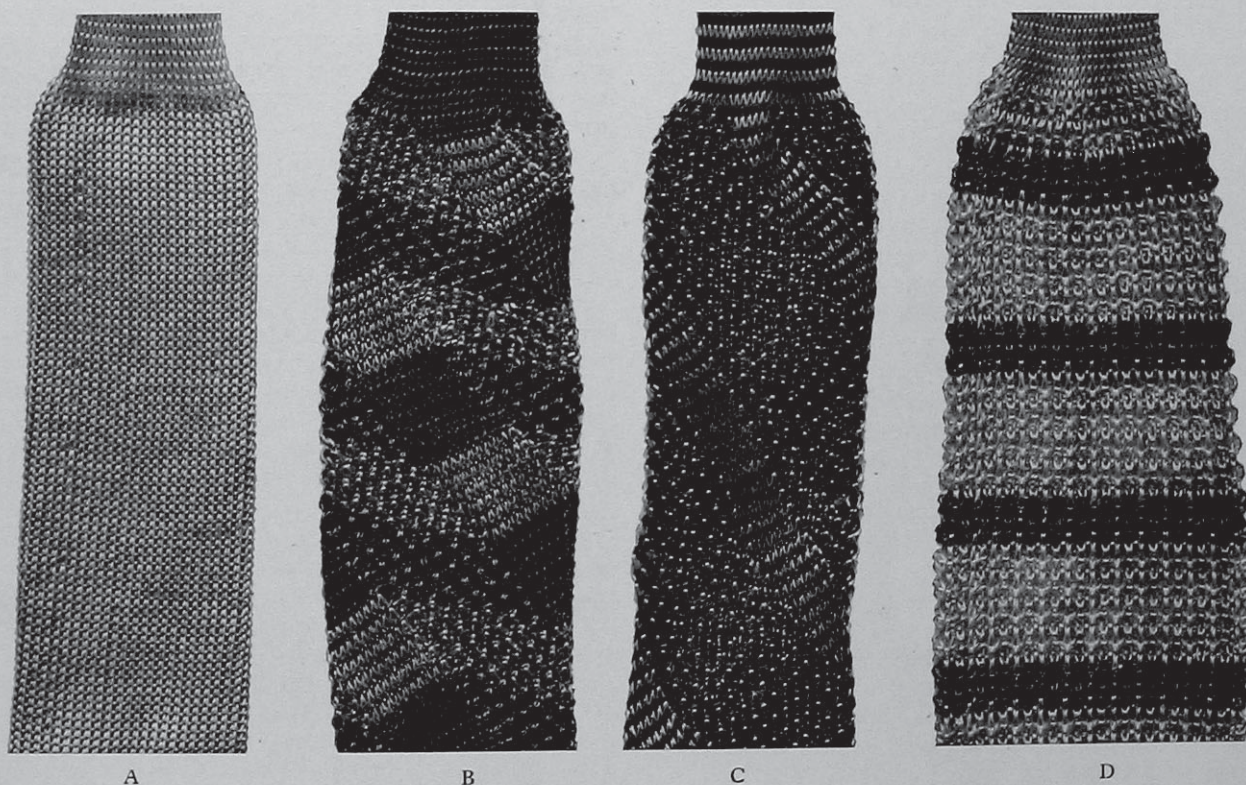

machines are in the market only since the last few months, they already have established *Knit Neckties* prominently in the market, and the demand for this machinery will become phenomenal during the next few months to come; Messrs. H. Brinton & Co., running already to their utmost capacity with orders ahead for months to come.

The head motion of the machine, although a masterpiece with reference to its technic of construction, designed by Mr. H. Brinton personally, at the same time is of such simple construction that the machine can be operated by any unskilled hand. In its general appearance, the new machine closely resembles the well known Brinton Full Automatic Knitting Machine; the only difference noticeable being several new attachments, viz.: a yarn changer, a striping attachment, a lace attachment and a take-up.

The Construction of the Machine. The first radical change noticed in the new machine is a small pattern wheel $2\frac{3}{8}$ inch in diameter, secured in an oblique position to the cam cylinder. This pattern wheel is grooved in irregular distances apart on its circumference; the number of these grooves in said pattern wheel and the distances they are apart from each other, being arranged either regularly distributed or arranged in sections of grooves, for producing the required pattern in the fabric. As will be readily understood, this pattern wheel is interchangeable, the change requiring nothing more than a moment's time, loosening a set screw and replacing the pattern wheel on the machine with the pattern wheel desired for the new style. The variety of these pattern wheels is unlimited; the cost of new pattern wheels for new styles of fabrics being about nil.

Practically speaking, there are three (3) distinct stitches used in the manufacture of these new Neckties, viz.:

- (a) The Plain stitch
- (b) The Tuck stitch, and
- (c) The Lace-effect stitch.

Either Plain and Tuck is used in combination, or Lace only, in the skirt of the necktie; the neck band, in either case, being Plain knitted. Plain and Tuck used in the skirt portions of the necktie, permit the production of an endless variety of new styles; in addition to which the Striping Attachment furthermore increases the variety of these possibilities for novelties.

TUCK STITCH. The pattern wheel, as previously referred to, is provided with grooves or notches on its circumference; being secured to the cam cylinder in such a position that the butts of the needles, as protruding out of the cylinder, have a chance to enter one of the grooves, provided such is presented when pattern wheel comes in contact with butt of needle. Any time that the butt of the needle in the cylinder of the machine thus enters a groove or notch in the pattern wheel, it holds the stitch of the yarn on the latch of the needle and knits Tuck stitch in the fabric.

PLAIN STITCH used in connection with Tuck Stitch. Any time that the butt of the needle in the cylinder comes in contact with the solid portion of the periphery of the pattern wheel, this raises the needle in the cylinder so as to cast the stitch off of the latch, knitting in turn Plain in the fabric.

As mentioned before, patterns are produced by the different combinations of this Tuck and Plain knitting; the third style of fabric structure possible to be made being Lace-effect stitch, which is produced by a special attachment on the back of the machine, and which can be used or not.

As will be readily understood, this small pattern wheel is only used in connection with knitting the skirt portions of neckties having for their principle of construction the combination of Plain and Tuck stitch, no pattern wheel being required when knitting Plain, whether for skirts, neckbands or cutting ends of any make of neckties.

In connection with necktie skirts, knitted with combination of Plain and Tuck stitch, which form the bulk of the demand for these fabrics, when the skirt of the necktie is finished, the pattern wheel is then thrown automatically out of operation by means of an ingenious cam arrangement, which brings all the needles up to a level, and when then the plain knitted neck band portion of the necktie is produced. When the latter is finished, by means of the same cam arrangement, the pattern wheel is then automatically brought into operation again, and the second skirt portion of the necktie knitted by means of Tuck and Plain structure combinations. When the latter is finished, the cam arrangement again throws the pattern wheel automatically out of action and when the machine then finishes the cutting end of the necktie with the Plain stitch. This completes the cycle of operation.

TEXTURE. The fabrics are at present constructed only with one gauge (12). The number of needles in the cylinder is 49, although as will be readily understood, more or less needles can be used, the number quoted being the present standard texture for these fabrics. The pattern wheel may be notched with an equal number of needles in the cylinder; again, and what is mostly in demand, is pattern wheels notched different from that of the number of needles in the cylinder, for instance 48 notches only in pattern wheel. This difference of needles in cylinder, vice versa notches in pattern wheel, (*i. e.*, one notch in example quoted is missed) produces a spiral (diagonal) effect in the fabric, since it throws the pattern wheel one needle out of the way at every round of the cam cylinder. The question now might come up in the mind of the reader, what two points of difference between needles in cylinder and notches in pattern wheel would produce; in answer to which we have to say that such a combination would spoil the general effect of the design in the fabric, on account of the oblique stripe (diagonal effect) running too flat (slanting) in the Necktie.

STRIPING ATTACHMENT. This attachment is also technically known as the Yarn Changer, and forms a most important adjunct to the new machine, for the fact that the changes in color combination are of equal importance to a fabric as the changes in stitches. Both affairs being at the command of the designer, the natural consequence is an endless variety of styles possible to be produced for these knitted neckties. Two colors are used by this yarn changer, in addition to the regular yarn as is fed uninterrupted on the opposite side from the yarn changer, to the needles of the machine. Which color, or kind of yarn, to bring into action by the striping attachment, is regulated by two different sizes (high and low) of projecting cams, screwed on the sleeve of the drum, in back of machine; said drum being provided with holes in one continuous line around its circumference to permit of any change of striping to be made.

Striping can be done either with Plain and Tuck combinations or with Lace-effect, but not in connection with the entirely Plain knitted neckties.

TAKE-UP. The same, closely resembles the usual take-up arrangement used in connection with knitting machinery, *i. e.*, the fabric, after leaving the head of the machine, runs over a large wheel (known technically as the cloth wheel) and which is covered with wire card clothing. This wheel operates directly the measuring device, which consists of a sprocket wheel secured to the same shaft to which the cloth wheel is secured (we will refer to this measuring device later on in detail). After leaving the cloth wheel, the fabric is then taken up by the usual two take-up rolls and which hold the fabric taut between them and the cylinder of the machine.

TO LOOSEN STITCH. When knitting the neck band and the cutting end of the necktie, a special attachment is automatically brought into operation, which raises the cylinder of the machine and consequently

loosens the stitch, to permit stretching of the neck band portion of the fabric.

MEASURING DEVICE. This ingenious attachment consists of a sprocket chain provided with high and low links, it being adjusted onto the sprockets of the sprocket wheel, fast to the shaft to which the cloth wheel is secured. The sprocket chain is held in position by means of a weighting wheel running in the inside of the chain. This measuring device is always in position for measuring the proper length of a necktie, whether the machine is running on a loose or a tight stitch. This measuring device might also be called the pattern regulating device, since by means of it the changes from Tuck to Plain, or vice versa, are automatically made by means of four high links, positioned in proper places in said chain. The first high link brought into action will change from Plain to Plain and Tuck or to Tuck, *i. e.*, from cutting edge to skirt portion. The second high link will change the knitting back to Plain knitting, of the neck band portion of the fabric. High link number three in turn will change the knitting back to the second skirt portion of the fabric, and when naturally the fourth high link will change the knitting of the latter portion of the fabric back to the plain knitting, *i. e.*, to the second cutting edge, or where we started from, and when the cycle of operation of the measuring device is completed.

As will be readily understood, in connection with Lace-effect Neckties, the cycle of operation of this measuring device is the same as just explained, the lace body portions of the fabric produced simply taking the place of plain and tuck stitch combinations used in the skirt portions of the fabric.

LACE-EFFECT STITCH. When changing the machine for this class of work, simply take off the small pattern wheel as secured to the cam cylinder; take out every other needle from the cylinder and insert in its place a special make of short latch needles. This now brings us into contact with two kinds of needles in the cylinder, *i. e.*, a long and a short latch needle. The long latch will accumulate yarn for several revolutions of the yarn carrier and when then the stitches are cast off automatically by the cam previously referred to when dealing with the combination of Plain and Tuck stitches, and when then it was used for regulating the change from Plain to Plain and Tuck, or vice versa, in the other make of knitted neckties, previously explained.

The short latch needles continue to knit all the time, while the long latch needles thus accumulate the yarn, until thrown into position to throw off said yarn by the cam, either on the second or third revolution of the cam cylinder.

In the illustration accompanying this article, fabric portions of four different constructions of such knitted Neckties are given. Only a portion of the neckband and of one of the skirts of each necktie is shown.

Diagram *A* shows a skirt constructed by Plain stitch knitting. In this case an additional thread is added when knitting the skirt portions of the necktie in order to give it a full appearance; the neckband

and also the cutting end of the necktie being produced with one-half the threads removed. No pattern wheel is used in the manufacture of this class of neckties.

Diagrams *B* and *C* show fancy combinations of Plain and Tuck, constructed with fancy grooved pattern wheels, producing a Diagonal Rib Effect in the skirt, as explained when describing the construction and working of the machine. Diagram *C* shows a Plain Color Combination effect, hence a distinct diagonal effect in fabric, whereas Diagram *B* shows the effect produced when using the Striping Attachment. The striping effect thus produced is clearly visible, in both the ground as well as the raised diagonal; the combination of both, on account of machine at the joining changing from Plain to Tuck, showing the wavy stripe effect seen in the illustration.

Diagram *D* shows a pattern produced by the Lace-effect Attachment, in connection with the Striping Attachment.

An Improvement to the Take Up for Circular Knitting Machines.

The object of this improvement is to intermittently and positively move the take up device a fixed distance. The device in its main parts consists in:

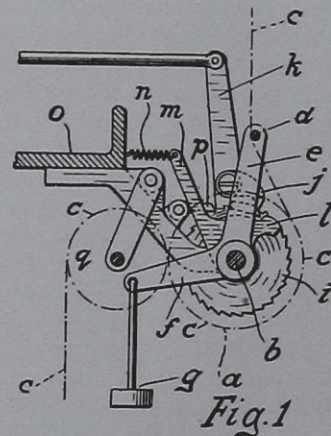

- (1) a take up roller driven by a ratchet and pawl;
- (2) a tension device resting against the fabric as it passes to the tension roller, and
- (3) a guard, controlled by this tension device, which normally holds the pawl inactive.

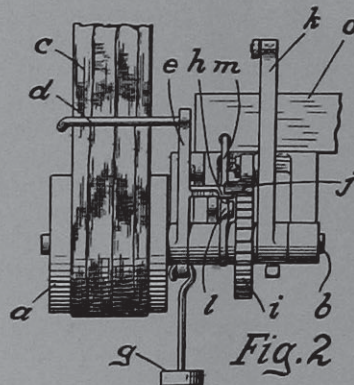

THE OPERATION OF THE DEVICE IS THUS: When in the course of knitting, the slack of the goods reaches

a certain point, the tension device then has moved sufficient to release the guard and allow the pawl to act upon the ratchet and move the tension device and the take up roller an amount sufficient to take up this slack. During this movement, the tension device is moved by the fabric in the opposite direction, an amount sufficient to again bring the guard into action and move the pawl out of action.

ILLUSTRATIONS: Fig. 1 is an end view of this take up device, with take up roller shown in dotted lines. Fig. 2 is a front view of the take up device, and Fig. 3 a perspective view of the same with take up roller omitted.

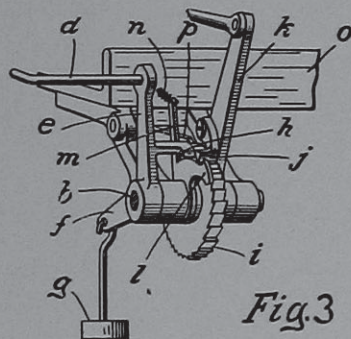

Letters of reference in our illustration indicate thus: *a* the take up roller, revolving with shaft *b*. *c* is the fabric. *d* a tension arm secured to the end *e* of crank arm *e-f*, as is movably secured to shaft *b*. Arm *f* of crank arm *e-f*, has connected to its outer end, weight *g*, which in turn moves arm *d* in a direction toward the fabric.

Connected to said arm *e* is guard *h*, which with the fabric taut, is slightly above the teeth of the ratchet *i*.

When in the process of knitting, the fabric commences to become slack, the arm *d* moves backward, until, with a certain amount of slack, it will have moved the guard *h* backward so as to uncover the guarded tooth. *j* is the operative pawl for the ratchet *i*, pivoted on the reciprocating arm *k*.

When the fabric is taut, guard *h* holds the pawl *j* from action, but when the fabric reaches a given slackness, this guard *h* is then moved backward and the pawl *j* becomes active, moving the ratchet *i* and the take up roller *a*, both revolving with shaft *b*, an amount sufficient to take up this slack. By this arrangement, the take up roller *a* is positively driven, but at the same time, its movement is dependent upon the feed of the fabric, thus retaining all the advantage of moving the take up roller by a weight, while on the other hand, the defects of non-positive driving are done away with. To prevent the pawl *j* in its idle reciprocation, striking the face of the tooth in ratchet *i*, in advance of the tooth, guard *l* is provided and which is connected to arm *m*, to which is connected one end of the spring *n*, the other end being connected to frame *o* of the machine.

The distance between the teeth of the ratchet *i* and the movement of the tension device to release the tension device guard *h*, are adjusted so that the pawl *j*

will be rendered active with the proper amount of slack of the goods, and the active movement of the pawl will cause the ratchet *i* to move sufficiently only to take up that slack of the goods. *p* is a holding pawl to prevent the ratchet *i* moving in the opposite direction. *q* is a guide roll, which takes the fabric *c* off the take up roll *a*.

THE BLEACHING, DYEING AND FINISHING OF KNIT GOODS.

(Continued from page 285.)

Bleaching. As all the fibres used in the manufacture of knit goods, wool, cotton and silk, have more or less natural color, knit goods made from unbleached yarns will themselves have more or less color, and consequently, if such goods are required to be a pure white, or if they are to be dyed light colors, this natural color must be removed by bleaching, since the scouring previously described does not materially change the color of the fibres, but only removes grease, dirt, etc. If the goods are made from bleached yarns, bleaching in the fabric is not necessary provided this bleaching of the yarn has been satisfactorily done, and then a good washing will be all that is required.

The question as to whether the yarn should be bleached or dyed before it is made up into knit goods, or whether the bleaching and dyeing should be done after the goods are made up, depends upon a good many conditions, not the least of which is the comparative cost of the two methods. It may be of advantage to use bleached and dyed yarns for certain classes of goods, such as open-work hosiery, for the less such goods are handled and the fewer the operations to which they are subjected, the less likelihood there is of their being damaged.

It is a common practice, especially in large textile centres, for knit goods manufacturers to send their unfinished goods to concerns (Public Dyers and Finishers) which make a specialty of bleaching, dyeing or finishing (as the case may require) of these goods, which afterwards are either returned to the mill for the final finishing, provided goods were only bleached or dyed, whereas some mills ship their goods (finished) direct from the Public Dyer and Finisher. Manufacturers who use yarns already bleached or dyed, or both, confine themselves simply to the actual manufacturing and finishing of underwear and hosiery. In either instance, such mills avoid the expense of a bleaching and dye plant. The advantages of this practice are that the manufacturer can put all his capital into machinery for actual production, besides having the benefit of the equipment and practical skill of concerns that make a specialty of bleaching, dyeing and finishing, which enables him to devote his whole attention to his manufacturing plant (production). Many mills, however, have to bleach, dye and finish their own goods, more so, mills located away from convenient reach to these public dyeing and finishing plants. As to the comparative cost of the two systems, much depends on local conditions. As

a matter of fact, it may be more convenient to do one's own bleaching than to have it done by a jobber in another place, but of course, in sections of the country where there are no concerns doing such work, it is a necessity for the manufacturer to do his own bleaching, etc.

The bleaching of yarn is an operation by itself and differs from that of knit goods, in the way the two are handled, although the principles and processes are the same in both cases. As the methods by which yarns are bleached are the same, whether the yarns are used for knitted goods or for woven goods, it is hardly necessary to refer to them here, as the student of knitting will be more interested in descriptions of methods and processes for bleaching the finished articles than in a description of methods involving yarns, which very likely he may never be called upon to practice.

Bleaching and dyeing are intimately connected, for many colors cannot be successfully dyed on unbleached yarns or goods in the gray. Again, other colors would be seriously impaired in shade or clearness if the bleaching were not properly done, or if traces of the chemicals used for bleaching were left on the fibres.

There are three recognized principles of bleaching of yarns or fabrics, based on the use of *chlorine*, *sulfur* and the *peroxides*.

As textile fibres vary in their behavior and resistance to bleaching agents, this must be considered in bleaching goods made from them, since the agent that will bleach one fibre satisfactorily and safely would cause serious damage to another fibre. For instance, cotton goods can be bleached with chlorine, but if wool were subjected to the same process it would be practically destroyed; and conversely, wool could be bleached with sulfurous acid gas, which would so tender cotton as to seriously affect its strength and utility.

With reference to bleaching by chlorine, this strictly refers only to bleaching cotton yarns or knit goods. This process in itself is very simple, provided proper care is exercised to rinse the goods thoroughly after bleaching, in order to remove any soluble chlorine compounds, which otherwise would adhere and make the yarn or knit goods tender.

Woolen goods can be bleached with sulfur, using the latter either as sulfurous acid gas, as derived from the fumes of burning sulfur in a closed chamber, or by combining acids with such chemicals that give off sulfur fumes in a bath. The sulfurous acid gas process has its advantages and disadvantages. The one advantage of this form of bleaching is its relative cheapness, which, however, is more than offset by the disadvantage that the goods thus treated do not remain permanently a pure white, but gradually become more yellowish, which is due to the action of the sulfurous acid upon the wool fibre under the influence of air (oxidation) and which changes the beautiful white, back to the natural color of the yarn or fabric previous to bleaching. Provided this sulfurous acid gas process is used, be sure to rinse the goods well after

bleaching, since the presence of any sulfurous acid may be antagonistic to the dyestuff used, and if so with the result of uneven shades in the yarn or knit goods.

Bleaching knit goods with sulfurous liquors also has its advantages and disadvantages. The greatest disadvantage is its cost, since a separate building is required, and for doing considerable work at one time a number of vats or tanks of special construction are required, together with an abundant supply of water, which must necessarily be free from dissolved iron salts and other impurities.

Considered all around it is a comparatively safe and easy operation to bleach knit goods made from wool, cotton or silk alone, but when cotton and wool or cotton and silk are used in the same fabric, the operation is not as easy and will require great care and judgment provided the old bleaching processes are used. The discovery and practical application of substances that will bleach all the textile fibres in one operation or solution equally as well, without damaging them, has been a great boon to the textile industry, and has greatly simplified the method of bleaching.

The most important of the modern bleaching agents that can be used on all kinds of fibres, is peroxide of hydrogen, which may be used in the form of an aqueous solution containing about 3% of absolute peroxide of hydrogen, or preferable, and more economical, which may be liberated in the bleaching liquid in a nascent state from peroxide of sodium, by the addition of sulfuric acid, in exactly the right amount, yielding hydrogen peroxide and sulphate of sodium, which latter chemical is harmless and is easily washed out of the goods after the bleaching is finished.

The advantages of the Peroxide process are exceptionally strong and should make this the ideal bleach for any class of goods, whether straight cotton, wool or silk or mixtures thereof, even though the cost of bleaching by this process is a little higher than that of lime or sulfur. The white obtained is permanent, there is no disagreeable odor attached to the goods, while the strength of the fabric is not injured in the slightest. The goods have an exceptionally soft feel, while the elasticity is better preserved than through any other process.

Bleaching with peroxide necessitates that the bleaching solution does not come in contact with metals of any kind except lead, since this would weaken its action. Be sure that you have a clean and pure water supply for the process.

Other peroxides, such as peroxide of calcium and peroxide of magnesium, have also been experimented with for bleaching purposes, but these have the drawbacks of greater cost, formation of insoluble compounds with acids or insolubility in water, which render their use, at present, commercially impracticable. Some of the alkaline perborates have also been suggested for bleaching, but their cost renders them unsuitable for most purposes, practically prohibitive on a large scale. Another process is the generation of nascent oxygen from the decomposition of water by

electrolytic action. The goods to be bleached are put in a tank containing water, which has been slightly acidulated to lessen its resistance to the electric current, and a current of electricity is passed through the water from electrodes (metal plates) on each side of the tank. By the action of the electric current, the water is decomposed into hydrogen and oxygen; the hydrogen being liberated as a gas from one of the electrodes while the oxygen, as fast as it is liberated, attacks the coloring matter of the goods immersed in the tank and thus bleaches them.

Another method for bleaching goods containing a mixture of cotton and wool, we may come in contact with, is by the use of a solution of an alkaline bisulphite with sufficient acid to liberate the active agent, sulfurous acid. The goods are put in the prepared solution and regularly worked during their immersion so that the bleaching will be uniform and thorough, being allowed to remain in the bath until bleaching is effected. After removal, the goods are drained and squeezed, or hydro-extracted, after which they are well washed, the first wash-water having a small amount of carbonate of soda dissolved in it to neutralize any acid that may have been retained by them. On account of the well known tendering effect of sulfurous acid, or its oxydation product (sulfuric acid) on cotton fibre, the operation of bleaching mixed goods with bisulphite of soda must be carefully watched and the goods not left in the liquor too long. Every trace of acid must be removed from the goods by a thorough washing, since if any acid is left, it will sooner or later injure the cotton fibres, and if the goods are to be dyed, will injuriously affect many of the dyes used.

Another process which is available but which is practically not used, is the use of permanganate of potash, followed by an acid to remove the brown deposit of oxide of manganese from the fibre. The process depends on the fact that when alkaline permanganates in solution come in contact with oxidizable organic matter, these molecules of oxygen are liberated with the reduction of the manganese to a lower oxide, this active oxygen attacking the coloring matter of fibres exposed to its action and consequently bleaching them. The process is carried out by immersing the goods in a dilute solution of permanganate of potash, allowing them to remain there until well coated with the brown oxide of manganese, after which they are taken out and put into a solution of sulfurous acid gas in water, or in a weak solution of soda bisulphite and sulfuric acid, and left there until all the brown deposit is dissolved and the goods appear white. They are then removed, drained, etc., and washed as usual. It is said that this process gives good results with silk, but since the use of peroxide of hydrogen or peroxide of sodium is much more satisfactory, the permanganate process is little used in this country.

Dyeing. The knit goods, after bleaching are ready for dyeing. If it is not desired to dye the knit goods, they are dried directly after the washing which follows the bleaching.

Previously to taking up the subject of dyeing, it must be mentioned that manufacturers should instruct their overseer to be careful and not put inferior goods into lots to be colored and finished for first quality goods; remembering, that many a perfect fabric has to be sold at less than cost price since seconds were found amongst them in the lot, mills not compelling their overseers to discriminate between perfects and seconds, when getting a lot of goods ready for the dyehouse.

The dyeing of knit goods can be conveniently divided into the dyeing of piece goods (small ware) and the dyeing of roll goods.

The accompanying illustration is a diagram of a convenient form of a machine for the dyeing of small ware, like hosiery, sweaters, mittens, toques, underwear, caps, etc., which come to the dyehouse in an unfinished condition, that is with reference to the underwear made up into unfinished garments. After coming to the dyehouse, the fabrics to be dyed, if dealing with colors requiring no bleaching, *i. e.*, the bulk of colors met with, are first boiled out (scoured), either in a special machine, or in the same machine as used for dyeing, and which consists of a tank for holding the dye liquor and through which the goods are passed, a wooden cylinder divided into compartments, which holds the goods to be dyed, and which revolves with its lower half submerged in the dye liquor, and a wooden cover which may either cover both the tank and cylinder or only the tank.

Referring to the illustration, 1 indicates the wooden tank made with heavy cast iron frames on each end of the tank, and to which the gearing is attached.

The cylinder 2 is made almost entirely of white pine and cypress, each end head being supported by a bronze casting, the hub of which is keyed to a shaft 3. The cylinder is divided into six compartments by the partitions 4, which are so shaped as to prevent the goods being matted together by the revolution of the cylinder during the dyeing process, thus enabling the goods to be more evenly and thoroughly dyed.

The partitions of the compartments consist either of perforated boards or series of round pins, so placed that a perfect circulation of the dye liquor is obtained. The steel shaft 3 is covered with wood on the inside of the cylinder to prevent the goods from coming in contact with the steel, and thus prevent rust spots on the goods. Each compartment is provided with a door 5, through which the goods to be dyed are loaded and after dyeing unloaded. The doors are perforated to allow the dye liquor to circulate from the tank through the compartments, and are provided with bronze hinges 6 and catches 7 to close and fasten said doors. A steam pipe is entered in the side of the tank at the bottom and extends across said tank. The goods, being inside the cylinder, are thus not disturbed or injured by the steam. An outlet valve for discharging the dye liquor, is located on the side of the tank.

The top covering of the machine (not shown) is supported on each end by cast iron frames and the openings at the back and front of the machine are

covered by canvas curtains which are rolled up during the loading and unloading process. The object of this top to the machine is to save steam, as it confines the heat; the volume of liquor is also reduced to a minimum, as compared with the amount of material being dyed, which results in using the dyestuff to the best advantage.

The cylinder is rotated by a driving arrangement, either from the side or from the back of the tank. When driven from the side, a worm gear is attached to the end of the main shaft 3, that runs through the centre of the cylinder, and this gear is driven from a worm located on the same shaft with the driving pulley. When driven from the back, a bronze rack is attached to the periphery of each end head of the cylinder, and the same driven from a shaft extending across the back of the tank on which are placed two pinion gears which mesh with the bronze rack. On the end of this back shaft is located a worm gear which is driven by a worm on the same shaft with the driving pulley. The back drive is preferable, for the reason that it relieves the main shaft of all strain, since the latter simply rests and rotates in the bearings on the sides of the tank. A crank is furnished with each machine, so that should accidents occur, or power be cut off, the machine can be operated by hand, thus preventing a batch of goods under operation from being spoiled.

The goods to be dyed are first counted so that each compartment will have about an equal share of the batch. The doors are then closed, after which the dyeing process is begun. The cylinder rotates slowly through the liquor and the goods are thus alternately brought into the liquor and then carried around with the cylinder. During this passage, the goods in each compartment fall from one side to the other, and thus are always in a different position when entering the liquor from that during the preceding immersion. In this way all parts of the material are exposed to the action of the dye liquor in the same degree. Care must be taken not to run the machines at too great a speed and cause the goods to roll and knot up, as this will cause uneven dyeing. One man can attend three or four machines. From 150 to 400 pounds of goods per batch can be dyed in a machine of this construction and from 5 to 10 batches per day, according to the material and the color to be dyed.

If possible different machines should be used for greatly contrasting colors, the dyer should not have to dye pink or browns in the same machine, because time is lost in cleaning out the machine so that no trace of the dye last used will be present to effect a greatly contrasting color of the dye to be used later.

The system of dyeing knit goods before cutting up the roll into pieces is done in a roll dyeing machine. The goods are sent for this purpose to the dye house in the form of rolls, as they come from the knitting machines. These goods are there unrolled and usually boiled out in an open kier, then put through a washing machine, and in turn extracted. After extracting, they are dyed in kettles provided with a reel over which several pieces of the

goods are passed, side by side, the two ends of each piece being sewed together so that the fabrics will continually pass through the liquor until the dyeing is complete. The pieces should be of about uniform length so they will all get the same circulation in the same time. If not of a uniform length, say for example, one piece is 100 yards long and another 200 yards in length, both traveling at the same rate over the reel, one would naturally pass out of the liquor twice as many times as the other, and what is likely to cause different shades in the same dyeing.

The dyeing of knit goods, whether in the piece or in the roll, necessitates care and experience. The

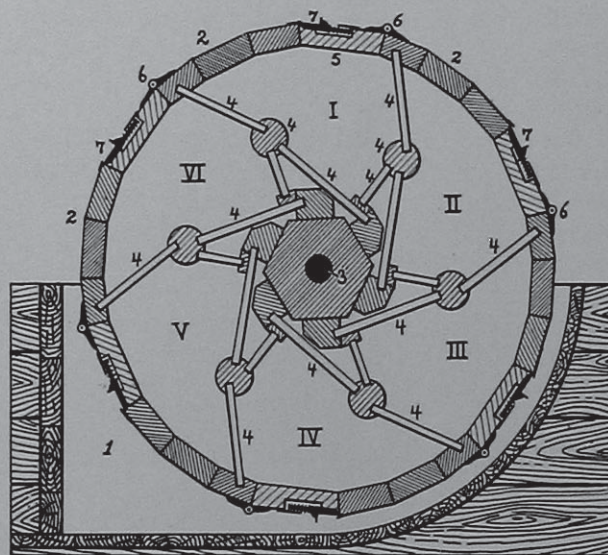

dyes used for the dyeing of knit goods are nearly all of the *direct* class, *i. e.*, dyestuffs requiring no mordanting. The dyes used are such as are known as *fast to washing and hot pressing*, at the same time easily soluble and result in *level dyeings*. No matter what the process of dyeing, care must be taken by the dyer to produce the best results. For this reason have your lots to be dyed of a uniform weight if possible; again, be sure that only a careful and reliable person attends to the weighing out of chemicals and dyestuffs, or better do this yourself. See that your scales balance, for the fact that more or less dyestuffs used may be the means of a change in the shade of the fabric, more so if dealing with light colors, requiring only a very small amount of dyestuff to be used, to produce the requisite shade. For light shades, the goods are generally boiled for one-half hour in the dye liquor before adding salt or Glauber's salt, and then the dyeing continued for one-half hour longer, in order to complete the dyeing and thoroughly exhaust the dye-bath.

As mentioned before, in connection with very light shades, the goods are bleached before dyeing, but in the bulk of the goods manufactured, this is omitted and the dyeing is done in the gray, after first scouring the goods thoroughly, as was explained in a previous chapter.

(To be continued.)

FULL FASHIONED HOSIERY.

Present and Future Shapes and Ways of Manufacturing.

Ever since machinery has been used for the automatic manufacture of *Hose* and *Half Hose*, machine builders as well as knitters have seen the necessity of producing better fitting shapes and at the same time do away with many complicated operations, to save time, increase production, and to obtain an article of higher intrinsic value.

The English and French foot hose dominate today the full fashioned hosiery market, and especially the latter found the largest number of wearers in the United States. England alone holds on to the complicated ways of manufacturing the *side seam foot* and *doubly shaped toe*, but the fitting of the latter article is not superior to the French foot.

It is the aim of this article to show how *this French foot* is made and fits and how new improved shapes have been produced and can be manufactured to greater advantage. With this in view, illustrations of both articles have been taken and are herewith given. The machine itself will be described further on and illustration of same will be given at the same time.

PLATE 1 illustrates a French foot on a form and shows the cause of so many complaints of hard walkers, suffering of hurts at the heel, where the heaviest weight of the body rests when standing or walking.

PLATE 2 shows the French heel and the improved Hilscher's Wedge heel, side by side. Examining the French heel, it clearly shows us between *A-B* the characteristic pouch formed at the back of the heel of a French foot hose. It is impossible to avoid this excess of fabric (see also *C* of Plate 1), which will bunch up and be the cause of an uncomfortable feeling to say the least.

Letters of references *B* and *D* of Plates 2 and 1 respectively indicate the spot where the seam in the sole meets the looped part of the heel and are crossed by the selvage of the heel cap, which had been transferred on to the needles, before the foot could be knit on to it.

As it is practically impossible to pick up the last row of stitches on the selvage or to stop the seamer as soon as the last loops are joined, without taking in the looping chain or leaving an opening or hole, we have to put up with the hard bunch at the crossing points *B* and *D*.

Hilscher's Wedge Heel Hose is an article of improved fitting qualities combined with comfort to the wearer and greater facilities in the manufacturing. It will be noticed that the pouch appearing on the French foot, (see *C* Plate 1 and near *A* Plate 2) has been done away with and that at the same time no interruption can be noticed in the fabric where the heel cap used to be. Thus the Hilscher Heel is a perfect fitting cap, following exactly the lines of the human foot. The only seam there is, runs under the whole foot and up in the back of the leg, it being run

through in one operation, without interruption, let off and starting points.

PLATE 3 gives a comparison between the two different feet, both turned inside out. Letters of references *E, F*, as given with the French foot correspond to letters of references *B* and *A* on Plate 2.

Examining the Hilscher's Wedge Heel Hose, it will be noticed that all the features distinguishing the Full Fashioned Hose from a Seamless, have been left undisturbed. The toe has the same perfect shape and the size or width of the foot has been reduced as many needles in the Hilscher hose as in the French foot.

With all the prejudice against deviation from old established forms, the practical man and buyer of the Full Fashioned Hosiery line will have to admit that the new Wedge Heel Hose is offering so many practical advantages, that it will be the article of the future and will have a ready market.

The appearance of an article on the counter, when put out for sale, is of just as much importance as the perfect fit of the hose on the foot. To show that the Hilscher Wedge Heel Hose in those respects is in no way inferior to the well known French foot article, several illustrations are given on PLATES 4 AND 5, demonstrating the appearance of the article when laying flat or being folded up ready to be put into the box. This point is brought to the special attention of buyers who might be induced to think that a Full Fashioned Wedge Heel Hose will have to be put into the same line as ordinary pouch heel seamless goods.

The superiority of the new line once uncontestedly established and proven, the manufacturer of such class of goods will be pleased to hear that he will be able to produce HILSCHER WEDGE HEEL HOSE with greater ease, less help, less power, on smaller floor space, save seconds and waste, mending and complaints, as will be demonstrated by a comparative illustration of two mills.

Following step by step the making of a fashioned hose or half-hose from the cone to the article ready for the Dye-house or the *Former*, we find that the operations are manifold and complicated.

(1) At least two different knitting machines are in general use to complete the web of the stocking (three for a sock or half-hose, as the rib top is made on a different frame). The first machine is usually called the *Legger*, as it produces only the leg part, with the two heel parts attached to it. The other is termed the *Footer* and knits the foot on to the leg.

(2) A transferring operation is necessary to pass the leg on to the second machine for completing. Not only the open stitches of the middle part of the foot have to be run on a transfer bar, but also the one selvage of the two heel caps. Several courses have to be unravelled and form waste.

(3) These selvages have a tendency to curl and before passing the heels on the transfer points, the operator has to use a special steel rod with a stub point, which she passes along the selvage border and

PLATE I

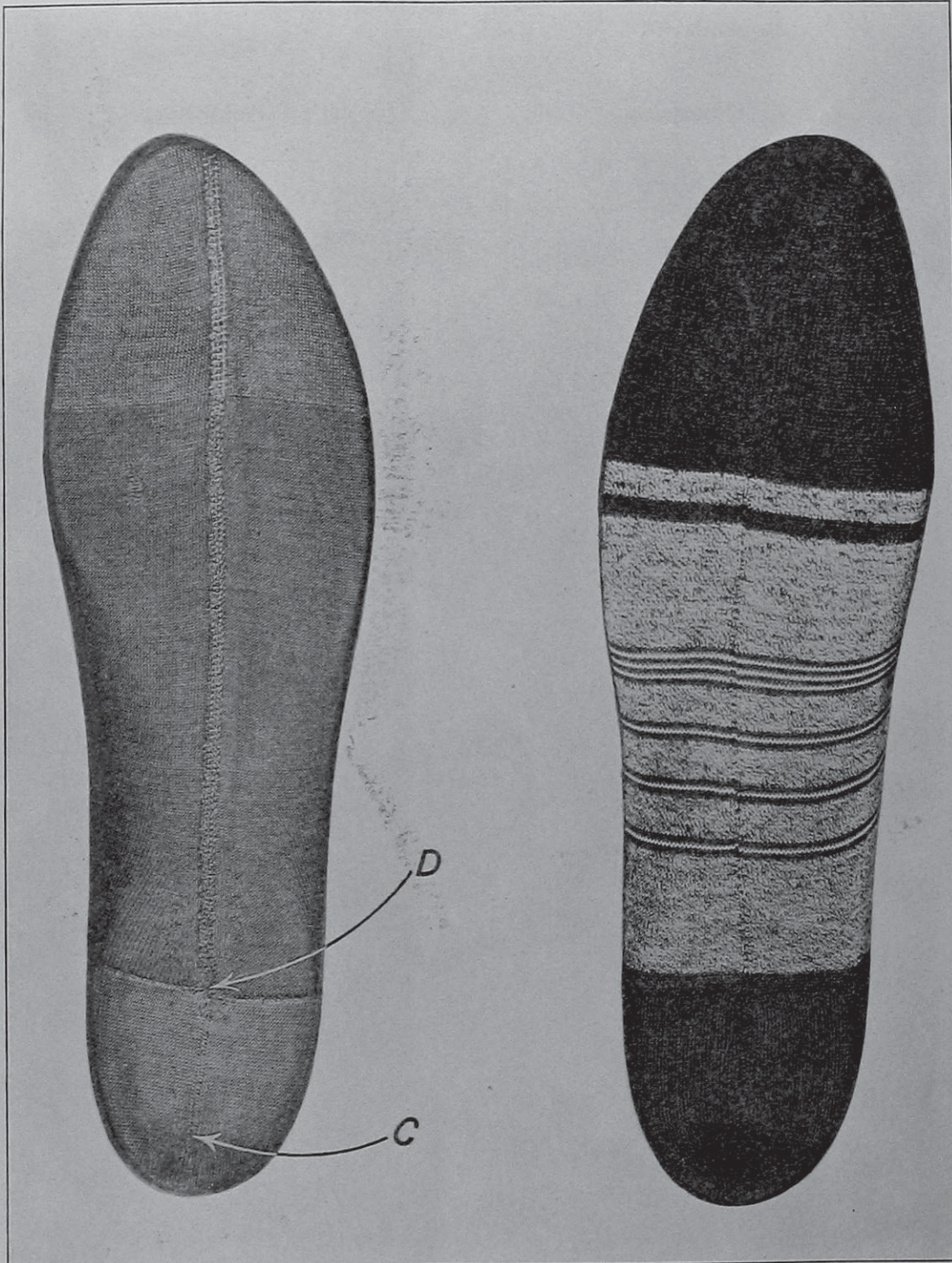

Inner-side out

FRENCH FEET

Outside

PLATE 2

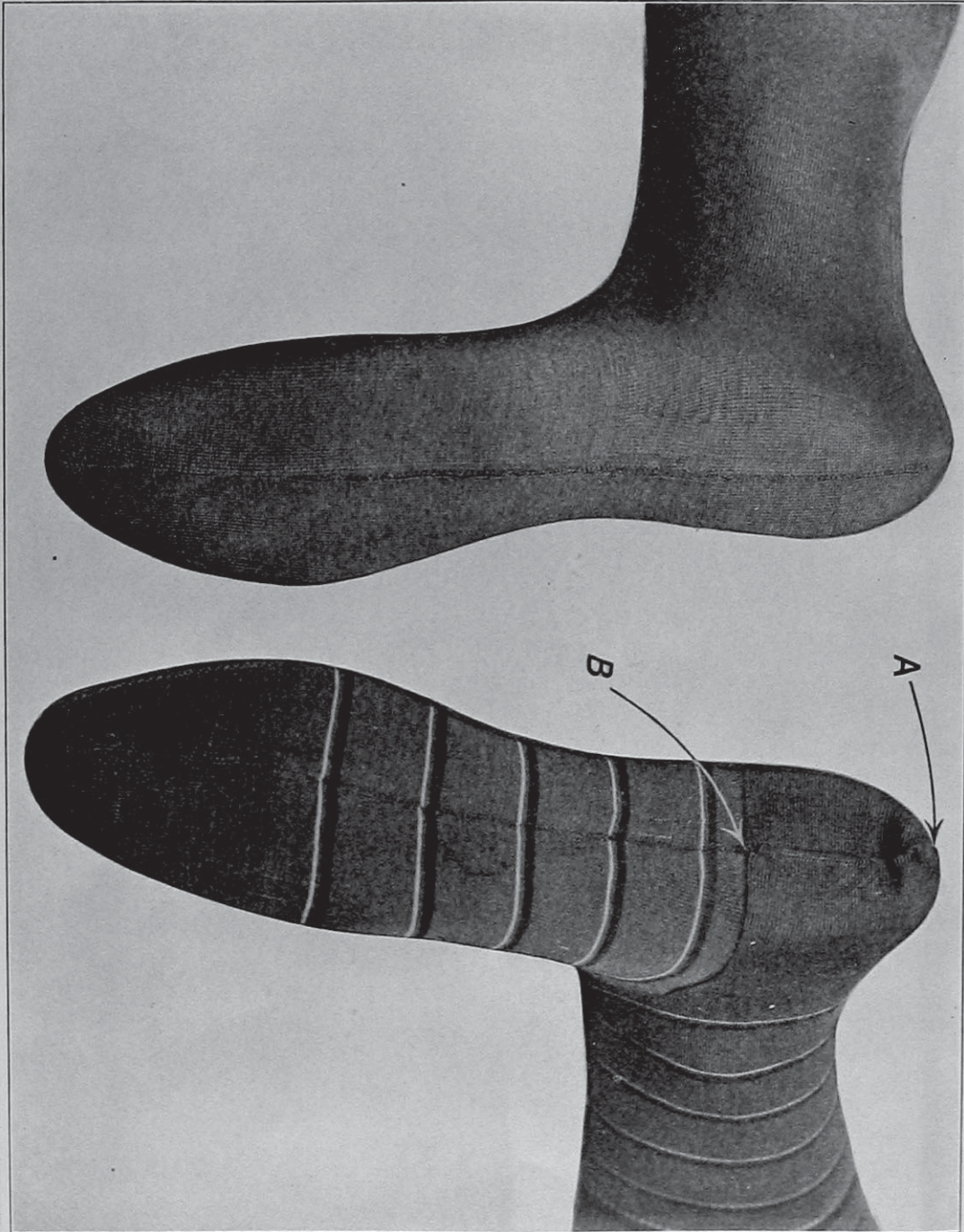

UPPER VIEW: HILSCHER'S WEDGE HEEL.
LOWER VIEW: FRENCH HEEL

PLATE 3



UPPER VIEW: HILSCHER'S WEDGE HEEL FOOT (inner side out)
LOWER VIEW: FRENCH FOOT (inner side out)