

loosely arranged on shaft *f* between bearing *i* and collar *m*, projecting laterally in the vertical plane of the toe *g* and has a lug *n*. A rock shaft *o* is journaled in the loom frame *b* and in a bracket *p* carried by the breast beam, the outer end of said rock shaft being formed as a crank *q* disposed contiguous to the limit of movement of the shipper lever in its *on* position; and *r* the shield controlling finger adapted to engage the lug *n* on the shield when depressed to throw the latter out of its interposed or depressed position, said finger *r* having the weight *s* acting normally to hold the rock shaft *o* in the position where its crank is in its limit of movement which is the nearer to the shipper lever.

When the shipper lever is thrown to the *on* position, to cause or not cause the actuation of the shield, according as said part is or is not in operative position to transmit the actuating influence of the shipper lever to the shield, a pivoted arm *t* is mounted on the side of the shipper lever adjacent to the crank of the rock shaft *o*, which arm, when in the position shown in full lines in Figs. 1 and 2 will engage the crank and rock the rock shaft when the shipper lever is pulled to the *on* position, but, when in the position shown in Fig. 3 in full lines and Fig. 1 in dotted outline, will stand clear of said crank so that the latter will not be engaged and the rock shaft not actuated. Thus, when the loom is running in its regular way, with filling, the arm *t* being then in the position shown in full lines in Figs. 1 and 2, the shield *k* is raised so that the dagger *h* will engage the toe *g* and rock shaft *f* to stop the loom upon failure of filling. When the loom is stopped, the shield falls back into shielding relation to the toe as soon as the movement of the shipper lever to the *off* position allows the weight *s*, to return the shield. If, now, the weaver desires to *turn the loom over* without filling, the arm *t* is moved to the dotted line position, shown in Fig. 1, or the full line position in Fig. 3, so that when the power is thrown on by pulling the shipper lever forward, the arm will not engage the crank on rock shaft *o* and move shield *k* out of interposed relation with respect to the dagger *h* and toe *g*.

DESIGNING AND FABRIC STRUCTURE FOR HARNESS WORK.

Producing Jacquard Effect Twills

BY DRAFTING FROM MOTIVES OR WEAVES 1:2.

This mode of constructing large fancy twills of 45° grading, for use on the harness loom, will result in well broken up effects, closely resembling Jacquard work, rather hard to be distinguished at a glance as harness work.

Rule: Draft alternately 1 end from one motive, foundation or weave and 2 ends from the other motive, foundation or weave; continue this drafting, over and over, until both motives, foundation or weaves are uniformly used up.

As will be readily understood, in order to obtain resulting twills of a large repeat, you must select foundations which, when combined, are not multiples at the first or second drafting over.

For instance, combing a 6-harness and 12-harness foundation 1:2 will result in a new weave of 18 warp threads repeat only, *i. e.*, once drafting each foundation will result in the repeat of the new combination weave.

Combining however, for example a 6-harness and a 13-harness foundation 1:2, will compel us to draft the 13-harness foundation twelve times over in order to be able to evenly use up this foundation with a 6-harness foundation, the combination resulting in a new weave repeating on 234 warp threads, of which 78 ends are drafted from the 6-harness foundation and 156 ends from the 13-harness foundation.

78 is evenly divisible by 6.

$156 \div 2 = 78$, and which is also evenly divisible by 13.

The number of harnesses required for the new large twill, as repeating on 234 warp threads, is (6 plus 13) 19-harness.

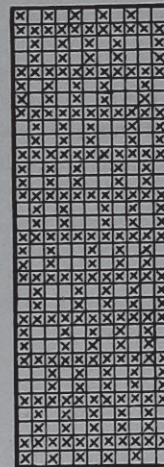

FIG. 1.

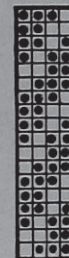

FIG. 2.

Filling ways, as will be readily understood, no reduction of picks can take place; the lowest common multiple of the repeat of both foundation weaves being the repeat for the new weave.

One practical example will explain the subject.

Fig. 1 shows us a motive (foundation) repeating on 11 warp threads and 33 picks.

Fig. 2 shows us another motive (foundation) repeating on 4 warp threads and 6 picks.

Repeat of our foundation weaves is thus 11 and 4 warp threads respectively.

The same drafted 1:2 will give 22 as the lowest common multiple of 11 (repeat of the motive as drafted one thread at one time) and of 2 (4 the repeat of the other motive, drafted 2 ends in succession=2 drafts in one repeat of weave); hence, repeat of the new combination weave:

22 ends for the 11-harness weave, drafted one end at one time, plus

44 ends for the 4-harness weave, drafted two ends in succession, before drafting from the other weave.

66 warp threads, repeat of the new combination weave.

Filling ways, the repeat of these two motives or foundations is 33 and 6 respectively. The lowest common multiple of these two numbers is 66; hence repeat of the new weave: 66 warp threads and 66 picks.

Fig. 3 shows us the new weave, and Fig. 4 a dia-

selection of weaves for these fabrics, we must be careful to select such as present plenty of filling floating on their face, since said floats furnish the means for producing, during gigning, the characteristic long hairy covering for the face of the fabric.

Figure 27 illustrates such a fur cloth fabric.

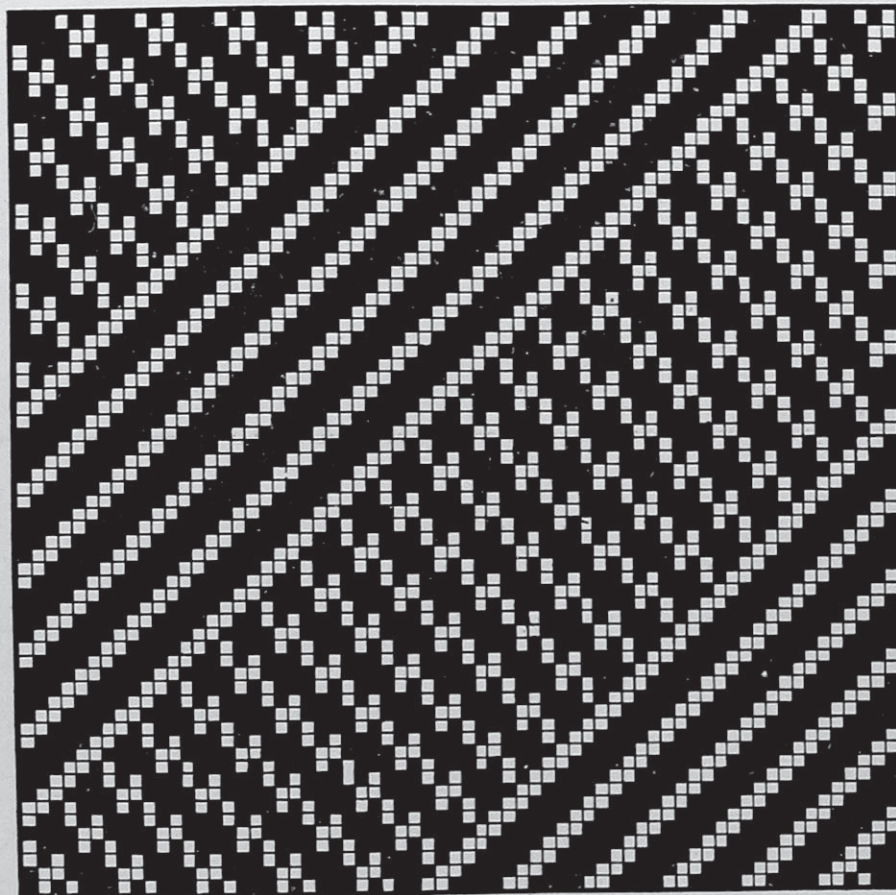

FIG. 3.

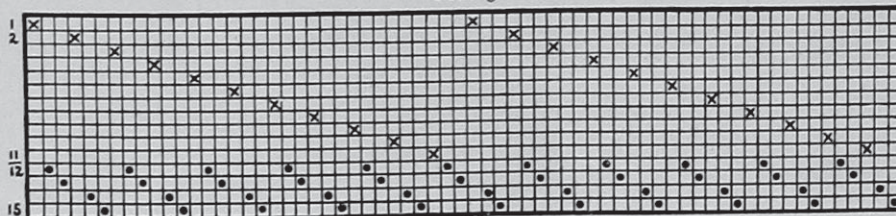

FIG. 4.

gram illustrating the drafting previously referred to, and of which *cross* type refers to our 11-harness foundation and *dot* type to our 4-harness foundation.

Fig. 4 also stands for the drawing in draft of this weave, calling for (11 plus 4) 15-harness.

THE MANUFACTURE OF OVERCOATINGS AND CLOAKINGS.

By N. Reiser.
B. Fur Cloth.

(Continued from page 99)

The same are a class of woolen fabrics presenting a long, hairy covering on their face, produced by more or less excessive gigning, for which reason in the

The use of weaves with plenty of filling floats is, as mentioned before, advisable, however, we may meet

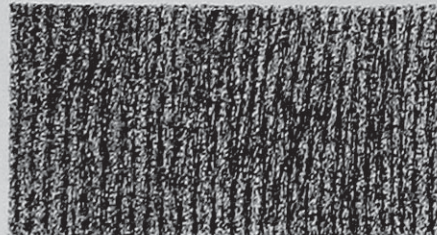

FIG. 27.

in the market with fur cloths in which the face shows warp effect, in fact we may come in contact with

beaver weaves used in the construction of these fabrics, however such cases are few and far between.

(1) SINGLE CLOTH, FUR CLOTH WEAVES.

In most cases, Fur Cloth Fabrics are heavy weight fabrics, although in some instances we may meet with medium weight structures. To produce the latter grade of fur cloth fabrics is the object of the present article. The Fur, *i. e.*, the face of the fabric, in the present system of weaves must be produced by a

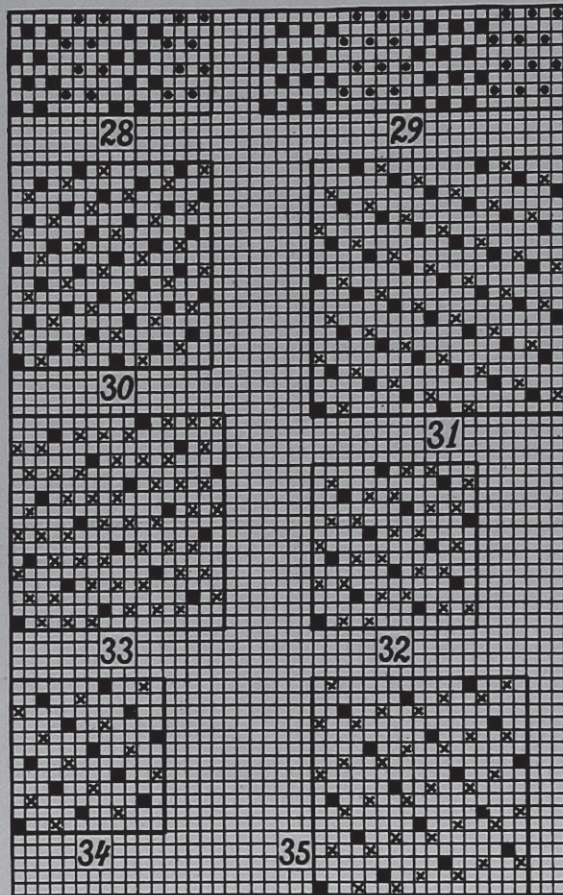

strong, yet loosely twisted yarn, by means of the characteristic weave, or wherever possible by means of both, so that gigging in the process of finishing the fabric can readily produce the required long hairy nap.

Specimens of weaves for this class of fabrics are given in connection with diagrams, Figs. 28 to 35. The more prominent these floats of the filling on the face of the fabric, the better a cover such a face of the fabric will present; however, we must at the same time remember not to overdo the matter, since too many and too excessive long floats will weaken the fabric.

To suit both, *viz.*, to give a full face, as well as to produce a strong fabric, we must construct our weaves so that they interlace solid in some places, and float on others. For example, let us consider weave Fig. 28. This weave has a repeat of 8 warp threads and 4 picks.

Pick 1 only interlaces for the first half of its repeat (see *full type*) on plain weave, floating for the other half of its repeat on the face of the fabric structure.

Pick 2 floats for the first half of its repeat, and interlaces on plain weave on the second half of its repeat (see *dot type*).

Pick 3 is the mate to pick 1, and pick 4, the mate to pick 2.

Weave Fig. 29 has for its repeat 12 warp threads and 4 picks. In this weave, every pick interlaces again on the plain weave for half of its repeat, floating on the face of the fabric structure for the other half. This principle of interlacing, observed, will clearly show that these weaves get sufficient interlacing to produce a strong fabric as well as sufficient floating of the filling to permit the production of a full, hairy cover.

Provided examples given, or any similarly constructed weaves, should show lines in the direction of the warp in the fabric, and which are not wanted, they being produced by the arrangement of exchanging the interlacing and floating of the filling under a regular arrangement, we then must distribute said places of interlacing. This is done in connection with weaves Figs. 30 to 33.

Weave Fig. 30 is constructed thus: Put the 8-leaf satin on 8 warp threads and 8 picks, as shown by *full type* in our illustration; next add one point of interlacing, arranged on the plain weave principle (one *down*, one *up*) to each original spot of the 8-leaf satin (see *cross type*). The floats, in this instance, are well distributed all over the entire surface of the fabric, and any formation of stripes in the finished fabric made impossible.

Weave Fig. 31 has for its foundation the 10-leaf satin (see *full type*) the principle of interlacing the filling being $\frac{1}{1} \frac{1}{1} \frac{1}{7}$

Weave Fig. 32 has for its foundation the 13-harness satin (see *full type*) the interlacing of the filling being $\frac{1}{1} \frac{1}{1} \frac{1}{8}$

Weave Fig. 33 has for its foundation the 17-leaf satin (see *full type*) the interlacing of each pick being $\frac{11}{1} \frac{1}{1} \frac{1}{1} \frac{1}{10}$

Weaves Figs. 30 and 31 are what we term *Double Satin Weaves*; Figs. 32 and 33 what we can term as *Triple Satin Weaves*.

Provided fabrics produced with weaves Figs. 28 to 33 handle too harsh, we must loosen their method of interlacing, *i. e.*, change the principle of the one *down* to two *down*, as clearly shown in diagrams of weaves Figs. 34 and 35.

Weave Fig. 34 has for its foundation the 12-leaf satin (see *full type*), for its interlacing of the filling $\frac{1}{2} \frac{1}{8}$

Weave Fig. 35 has for its foundation the 17-leaf satin, and for interlacing of the filling $\frac{1}{2} \frac{1}{2} \frac{1}{10}$

In connection with either weave, the filling used must be sufficiently soft in its twist, and the material used, sufficiently long, to permit during gigging the raising of the characteristic long, hairy nap desired.

(To be continued.)

NOVELTIES IN MEN'S WEAR.

FROM ABROAD.

Worsted Trousering. (Silk Mix.)

Warp: 6160 ends.
Weave: See Diagram Fig. 1; repeat 110 warp threads and 5 picks; 10-harness fancy draw.
Reed: 19½ @ 5 ends per dent, 97½ ends per inch, 64 inches wide in reed.
Dress: 2 ends A, 6 B, 2 A, 10 B, 2 A, 6 B, 2 A, 35 B, 2 A, 6 B, 2 A, 35 B; Total: 100 ends in repeat of pattern.
 14 Sections @ 4 patterns or 440 ends to each section.
Descriptions of Yarns to use:
 A: 2 ply 52's worsted, black twisted over with white silk 150,000 yards per lb.
 B: 2 ply 48's worsted, black.
Filling: 70 picks per inch, 2 ply 60's worsted, black.
Finish: Worsted finish, 56 inches wide.

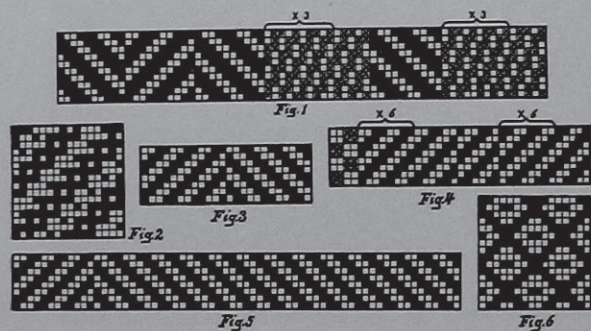

Fancy Worsted Diagonal. (Stripe.)

Warp: 6720 ends.
Weave: See Diagram Fig. 2; repeat 16 warp threads and 16 picks; 16-harness straight draw.
Reed: 17 @ 6 ends per dent, 102 ends per inch, 66 inches wide in reed.
Dress:
 1 end ¼/8's worsted, blue gray mix } 12 times
 1 " " " , black }
 1 " 2/52's " , black and 1¼/13 white silk. } 12 times
 1 " 2/48's " , black }
 1 " " " , blue gray mix } 12 times
 1 " " " , black }
 1 " " " , blue green } 12 times
 1 " " " , black }
 96 ends in repeat of pattern.
 14 Sections @ 5 patterns or 480 ends to each section.
Filling: 90 picks per inch, arranged thus:
 1 pick 2/66's worsted, black
 1 " " " , blue green
 2 picks in repeat of pattern.
Finish: Worsted Finish, 56 inches wide.

Worsted Suiting. (Stripe effect.)

Warp: 4680 ends, all 2 ply 52's worsted.
Weave: See Diagram Fig. 3; repeat 24 warp threads and 4 picks; 8, 12 or 16-harness fancy draw.
Reed: 18 @ 4 ends per dent, 72 ends per inch, 65 inches wide in reed.
Dress: 3 ends slate and medium gray twist } 10 times
 3 " black }
 3 " light gray and medium gray twist } twice
 3 " black }
 72 ends in repeat of pattern.
 13 Sections @ 5 patterns or 360 ends to each section.
Filling: 65 picks per inch, arranged thus:
 1 pick 2/62 worsted slate and medium gray twist
 2 picks " " black
 3 picks in repeat of pattern.
Finish: Worsted finish, 56 inches wide.

Worsted Suiting. (Check.)

Warp: 4680 ends, all 2 ply 52's worsted.
Weave: See Diagram Fig. 4; repeat 117 warp threads and 4 picks; 8, 12 or 16-harness fancy draw.
Reed: 17½ @ 4 ends per dent, 68 ends per inch, 66½ inches wide in reed.
Dress: 4 ends black and olive green
 2 " dark moss green } 13 times
 2 " black }
 1 end dark moss green
 2 ends black } twice
 1 end coffee brown }
 2 ends black }
 11 " dark moss green } twice
 11 " black }
 8 " dark moss green }
 117 ends in pattern.
 10 Sections @ 4 patterns or 468 ends to each section.
Filling: 66 picks per inch, arranged thus:
 2 picks black } 18 times
 2 " dark moss green }
 12 " dark moss green } twice
 12 " black }
 12 " dark moss green }
 132 picks in repeat of pattern.
Finish: Worsted finish, 56 inches wide.

Woolen Cheviot Suiting. (Stripe.)

Warp: 2304 ends.
Weave: See Diagram Fig. 5; repeat 64 warp threads and 4 picks.
Reed: 17½ @ 2 ends per dent, 35 ends per inch, 66 inches wide in reed.
Dress: 1 end 4½ run white } 16 times
 1 " 3¾ run black }
 1 " 2 ply 20's spun silk, white }
 3 ends 2 ply 32's worsted, black and white twist }
 1 end 2 ply 20's spun silk, white }
 1 " 3¾ run black } twice
 1 " 4½ run white }
 2 ends 3¾ run black }
 1 end 4½ run white 24 times }
 1 " 3¾ run black }
 1 " 2 ply 20's spun silk, white }
 3 ends 2 ply 32's worsted, black and white twist }
 1 end 2 ply 20's spun silk, white }
 1 " 3¾ run black } 7 times
 1 " 4½ run white }
 1 " 3¾ run black }
 1 " 2 ply 20's spun silk, white }
 3 ends 2 ply 32's worsted, black and white twist }
 1 end 2 ply 20's spun silk, white }
 1 " 3¾ run black } 3 times
 1 " 4½ run white }
 1 " 3¾ run black }
 128 ends in repeat of pattern.
 6 Sections @ 3 patterns or 384 ends to each section.
Filling: 36 picks per inch, arranged thus:
 1 pick 3¾ run black
 1 " 4½ run white
 2 picks in repeat of pattern.
Finish: Cheviot Finish, scour well, dry, clip on shear, 56 inches wide.

Melton Suiting. (Novelty Effect.)

Warp: 3296 ends.
Weave: See Diagram Fig. 6; repeat 8 warp threads and 8 picks.
Reed: 12½ @ 4 ends per dent, 50 ends per inch, 66 inches wide in reed.
Dress: 1 end 2 ply 32's worsted, light gray mix
 1 " " " , brown and white twist
 2 ends in repeat of pattern.
 8 Sections @ 206 patterns or 412 ends to each section.
Filling: 42 picks per inch, all 2 ply 32's worsted, black.
Finish: Worsted Melton finish, scour well, full slightly, dry, clip on shear, 56 inches wide.

DICTIONARY OF WEAVES.*

TWELVE HARNES

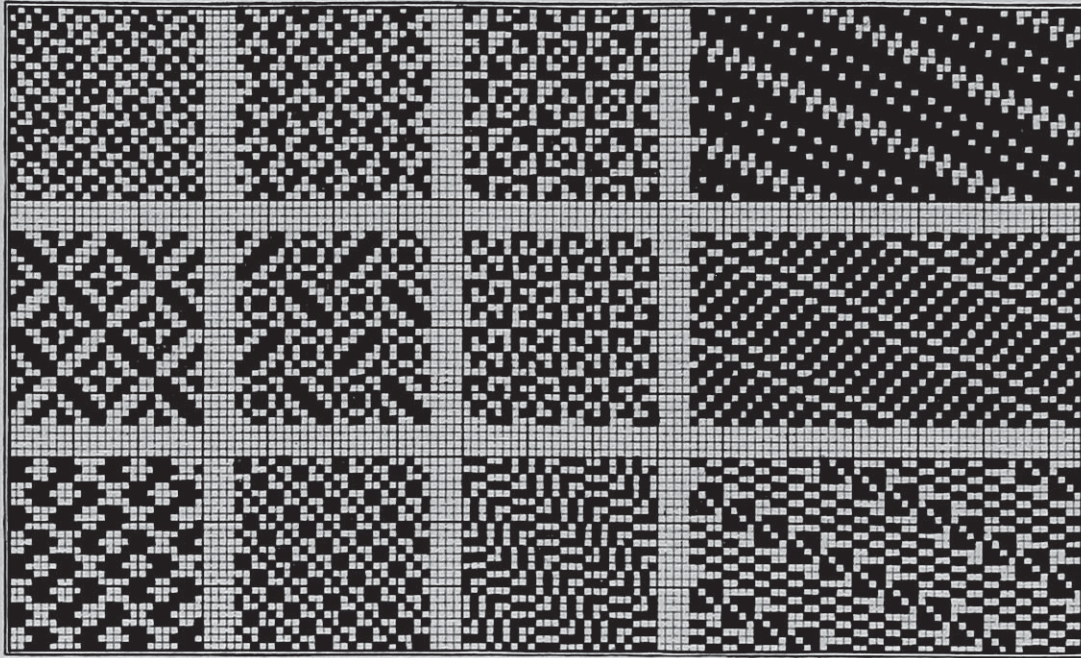

12 X 24

12 X 12

TWELVE HARNES

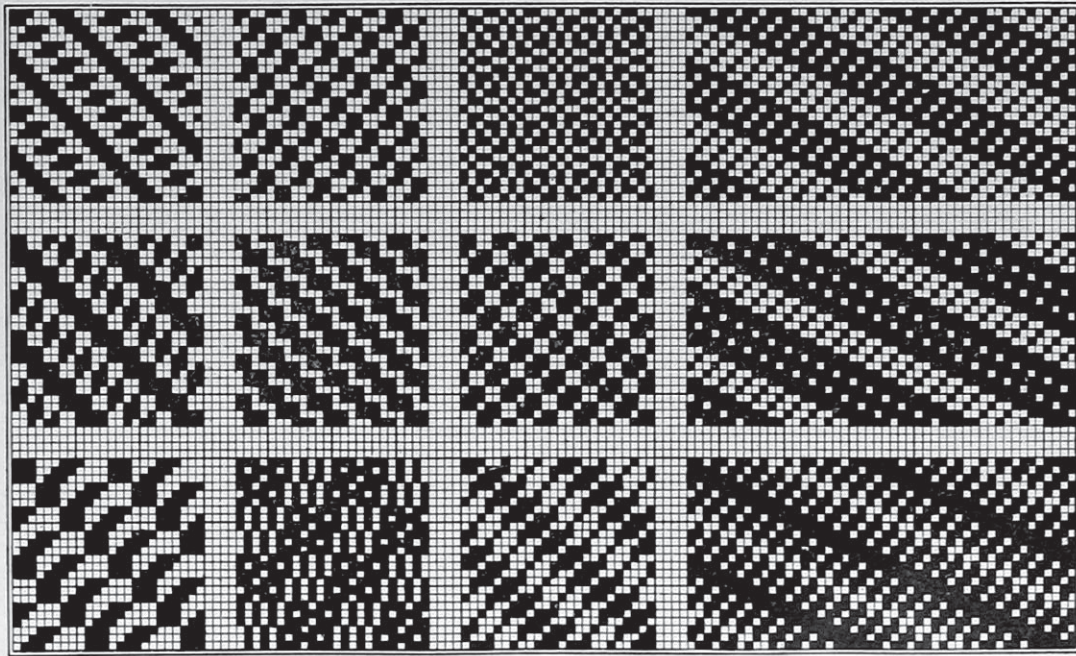

12 X 24

12 X 12

*Complete, this Dictionary will contain over TWENTY THOUSAND PRACTICAL WEAVES, taken from woven Fabrics. About One Thousand Five Hundred of them have thus far appeared, and can be obtained by ordering back numbers.

A New Sinker for Knitting Machines.

The object, construction and operating mechanism for this new *Sinker* is, to do away with the chances of excessive accumulation of lint in the Head Motion of Knitting Machinery, which feature, in turn results

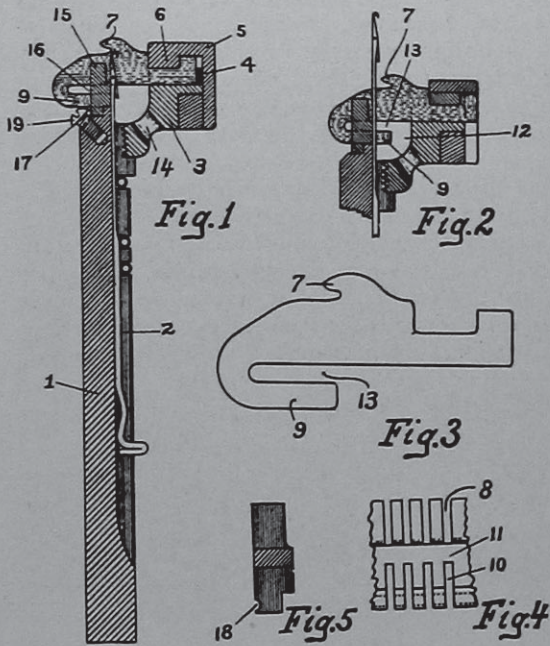

in wear and strain upon the sinkers and its operating cams, giving a chance for imperfections in the fabric being knit.

The new construction will simplify labor to the operator, since little, if any, cleaning will have to be done, and if so, the construction is such, that it can be done more conveniently.

The shape of the new sinker and its operating mechanism will be readily understood, by consulting the accompanying five diagrams, and of which Fig. 1 is a vertical sectional view, through one side of a needle cylinder, showing the new form of sinker, the same being shown in its advanced or holding position; Fig. 2 is a similar view, showing the upper end of the cylinder, with the sinker retracted in position for the drawing of the loops by the needles; Fig. 3 is a side elevation of a sinker on an enlarged scale, compared to that shown in Figs. 1 and 2; Fig. 4 is a fragmentary view of the throat ring of the needle cylinder, and Fig. 5 is a vertical sectional view through the throat ring; both diagrams being drawn on an enlarged scale compared to Figs. 1 and 2.

A description of the construction and working of the new sinker is best given by quoting numerals of references accompanying the illustrations, and of which 1 indicates the needle cylinder, 2 the needles, 3 the sinker ring, 4 grooves for the needles, 5 sinker cam ring, 6 cam rib, 7 finger of sinkers, which overlie the edge of the fabric when the sinkers are in the position indicated in Fig. 1, and hold down the fabric as the needles rise through the loops, and which are withdrawn from holding position, as indicated in Fig. 2, when the needles are to draw new loops during

the knitting operation. The outer ends of the sinkers are prevented from rising in the sinker ring by the sinker cam ring which overlies them. The sinkers extend forward from the web retaining hooks and are guided and supported laterally by radial slots 8 formed in the upper end of the needle cylinder. The inner ends of the sinkers are held down by means of retaining fingers 9 which extend radially outward or rearwardly of the sinkers, and pass through guiding slots 10, formed in the upper end of the cylinder immediately below the slots 8 from which they are separated by webs 11 which form a ring for holding down the inner ends of the sinkers. The holding down fingers 9 pass into and out of the annular space 12 between the sinker ring and the upper end of the needle cylinder as the sinkers are reciprocated.

With this construction, the inner ends of the slots or recesses 13, between the fingers 9 and the bodies of the sinkers are open.

Any lint which may collect within the annular recess 12 may be readily removed through openings 14 formed in the sinker ring.

15 is a throat ring secured to the cylinder 1, forming the upper portion of the latter, and being provided with a series of slots (see Fig. 4, which represents the front view of said throat ring). 16 refers to an annular rib, 17 to a split, locking ring, and 18 to a recess formed in the inner side of the throat ring; the split, locking ring 17 being clamped in position by means of screws 19.

A New Hosiery Singeing Machine.

The object of this Machine is to do away with the cumbersome and always more or less inefficient methods of singeing stockings, placed on wooden forms, by machinery built for this purpose.

In the new Machine, the stockings have a fixed path of movement, enabling the singeing flames to

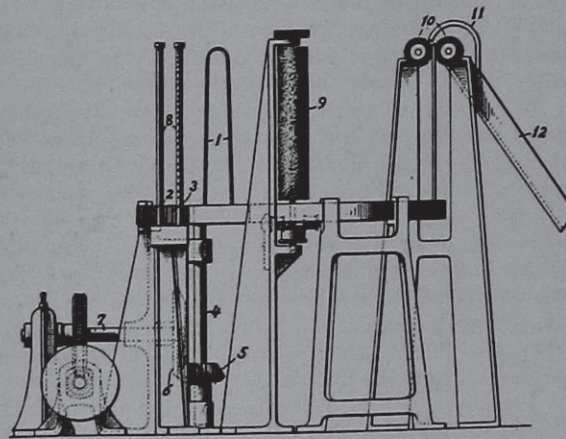

properly attack the loose fibres on both sides of the stocking, and this within the interstices thereof. The stockings are fed to the flames widthways, or crossways as we might say, in turn requiring only a moment's exposure of the stocking to the flames, hence effecting a material saving in the amount of gas used.

To convey to the reader a thorough understanding of the construction and working of this Singeing Ma-

chine, the accompanying illustration is given, the same being a side elevation of the Machine, showing its most vital parts.

Examining this illustration in detail, we find supported on suitable standards a carrier, which has arranged upon its upper edge a plurality of upwardly extending supporting forms 1, only one being shown in our illustration, three as a rule, equally distanced apart, being used. The carrier is provided with internal gear teeth 2, which mesh with a pinion 3, carried in shaft 4, which has fast to it a bevel gear 5, which in turn meshes with a mutilated bevel gear 6, carried in shaft 7.

The gear 6 is mutilated in such a manner as to impart an intermittent movement to the carrier, imparting to the latter a series of periodical dwells.

SINGEING.—The unsinged stockings are applied to each of the forms 1 previous to then entering between burner tubes 8, the carrier being at rest at such time, caused by the action of the mutilated gear 6 previously referred to. When the teeth on gear 6 again mesh with teeth on gear 5, shaft 4 is caused to rotate sufficiently to pass the unsinged stockings between the burner tubes 8, bringing the same afterwards again at rest at a point between the burner tubes and the brushes 9. The next intermittent movement of the carrier will bring the now singed stocking between the brushes 9, which in turn will remove the burnt fuzz from the stocking.

STRIPPING.—When the carrier again comes to rest, the form then lies in proper position between the two stripping brushes 10; the action of said two brushes being such as to draw the singed and cleaned stocking from its form, the stocking in turn being guided by means of a deflected hood 11 into a chute 12, discharging it into a receptacle or wherever desired.

An Ingenious Hosiery Dyeing Machine.

This new Dyeing Machine refers to the open-vat type, with provisions for the dye liquor to circulate within the vat during the dyeing operation.

In addition to this circulation of the dye liquor, means are also provided in this new dyeing apparatus whereby the goods under treatment may be agitated, to permit the dye liquor to more thoroughly permeate the mass.

Besides dyeing, this machine may also be used for the washing of goods after they have been dyed, the construction of the machine being such that the drum, containing the goods, can be readily removed to another machine, without disturbing the circulating mechanism in either machine.

Provisions are also provided in the construction of the new machine, that enables the operator to stop its circulating mechanism without affecting the operation of the drum, and vice versa, so that should conditions require the same, the dye liquor, or water for washing purposes, as the case may be, within the vat, can remain in a quiescent state while the drum can continue to rotate, or the drum may be brought to rest while the circulation of the dye liquor, or the wash water, continues.

The machine is of special advantage in the softening of the goods, such as for example, stockings, after the latter have been dyed and washed. Ordinarily, in this softening operation, the agitation of the soapy solution causes a deposit of small particles of a curdy nature on the outside layers of the goods. With the present machine, however, it is possible to soften the stockings by merely causing the drum to revolve and thereby tumble the goods around in the soapy solution, the propellers not revolving but remaining at rest, and, consequently, the soap will not be churned up into curds. The stockings, therefore, will emerge from the machine soft and delicate to the touch, and free from the curdy deposits mentioned.

The accompanying illustration represents an end elevation of this new dyeing machine. A description of its construction and operation is best given by quoting numerals of references accompanying the illustration, and of which 1 designates the vat, for holding the dye liquor or the water for washing the goods before or after dyeing.

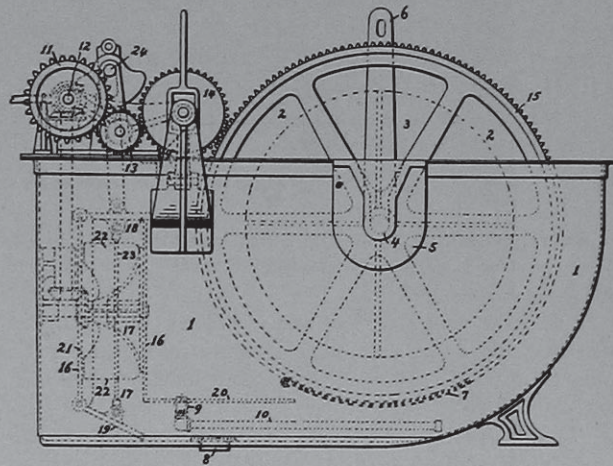

Within this vat, adjacent to the curved end thereof, is a drum 2, having solid heads 3, provided with trunnions 4 seated in bearings 5.

While the drum 2 is supported in the vat 1, the same is free to be removed therefrom, the heads 3 of the drum 2 being for this purpose provided with a radially extending hoisting standard 6, fixedly connected to the head 3.

The drum 2 may be either of iron or wood suitably perforated, or the same may be of wire fabric, to permit the dye liquor freely entering the drum in order to permeate the mass of the material treated, and in order that access may be readily had to the interior of the drum the latter is provided with a hinged door 7 through which the material to be dyed or washed can be readily inserted and removed from the same.

The vat 1 is provided with an outlet 8, and associated with said vat is a pipe 9 having branches 10 through the medium of which steam is introduced to the dye liquor within the vat when so desired.

A sprocket wheel 11, fast to shaft 12 transmits power to the machine. A power gear (not seen in illustration) is carried on shaft 12, said gear, through idler pinion 13, shiftable gear 14, and spur gear 15,

rotating drum 2; the movement of the latter being essentially controlled by the shiftable gear 14.

For freely circulating the dye liquor, the vat has located in the end thereof, opposite to the end wherein the drum 2 is journaled, a pair of transversely extending partitions 16, which extend across the entire width of the vat and are spaced from each other to provide a compartment 17. The upper and lower edges of said partitions terminate at points removed from the top and bottom of the vat so that spaces remain at the top and bottom of the compartment 17, whereby the dye liquor can readily pass over and under said compartment. The upper and lower ends of the compartment are closed by valves 18 and 19, said valves being in the form of doors, pivoted at their outer edges to the upper and lower edges of the outer partition 16. The valves 18 and 19 control the direction of circulation of the dye liquor; when one is closed the other is opened. Valve 18 is shown in closed position, while the valve 19 is shown open. The dye liquor, in circulating through the compartment 17, will thus be discharged at the bottom thereof, while this discharge will occur at the top of said compartment when the position of the valves is reversed to that shown in our illustration. 20 is a deflector plate which forms a passage between said plate and the bottom of the vat to insure circulation of the dye liquor along said bottom, to the extreme lower edge of the drum 2.

That the dye liquor may freely enter the compartment 17, the outer partition 16 is provided with an opening or openings 21. For effecting circulation of the dye liquor, a plurality of propeller wheels 22 is arranged in the compartment 17, and as said wheels rotate, they suck the dye liquor through said openings into said compartment. These wheels 22 are made to rotate in opposite directions, that is, one of the wheels will rotate toward the right, while the direction of rotation of the other wheel will be to the left, an arrangement which insures uniform distribution of the dye liquor as the latter is projected from the compartment 17 into the vat 1.

For reversing periodically and automatically the direction of flow of the dye liquor, as the latter circulates in the vat, valves 18 and 19 are alternately opened and closed, these valves moving in unison by means of a connecting rod 23, suitably pivoted to both of the valves.

If it is desired at any time to stop reversal of the circulation of the dye liquor, it is only necessary to disconnect, at the front of the machine, a collar from a worm, whereupon a cam shaft 24 ceases to operate, and movement of the valves 18 and 19 is thereby stopped.

If it be desired to stop rotation of the propeller wheels 22, as is sometimes desirable when the machine is employed for washing the materials after the same are dyed, this is accomplished by disengaging a clutch collar from the shaft which operates the propeller wheels 22, in which event, the shaft 12 continuing to operate, the drum 2 will continue to revolve and tumble the goods around in the wash water. The

gear 14 can be readily shifted upon its shaft, and when the same is disengaged from the spur gear 15, the drum 2 can be readily removed from the vat for transfer to another machine, or for removing the goods therefrom, without having to disturb the circulating mechanism.

Dyeing and Cleaning in Germany.

Dyeing and cleaning works are highly developed in Germany. The writer recently visited one of the best in the country and found it electrically driven throughout; steam is used only for the dyeing operations. A good supply of soft-water being essential the water from the district is softened by adding soda and passing through a filter press; it is stored in a large tower.

Benzine cleaning is used for all kinds of articles. Gloves are cleansed by this liquid by merely brushing it on to them, while clothes are treated in a machine consisting of two concentric cylinders, the inner one being perforated and revolving in the benzine. The outer one contained the benzine which penetrated the perforations of the inner one and saturated the material contained therein. The principle is the same as that of the *Klauder-Weldon* raw stock dyeing machine and the arrangement is very simple.

In all cases the benzine is kept as much as possible from the air. Great precautions are taken against fire, alarms being fitted above the benzine vats. If the vapor of the benzine rises above a certain temperature then by means of an electrical arrangement a bell is made to ring. This temperature is far from the ignition point of the benzine vapor so that the warning given by the bell ensures safety. The benzine is stored under ground. After use it is recovered by distillation. This is done from large retorts, the temperature of which can be carefully regulated. The vapor is condensed in a coil by means of cold water and run into cisterns below. Soap cleaning is done by scrubbing on marble slabs in the ordinary way. The soap is recovered. Washing is sometimes done in troughs, the goods being kept in motion by means of a paddle. Goods are dyed either in a similar trough or on a frame which is kept moving up and down in the dye liquor.

The feather drying and trimming is performed by allowing the feathers to revolve and catch loosely against a piece of flannel once every revolution. This gives them a nice finish, but in some cases hand trimming is employed. For finishing purposes small calenders are employed, but in the case of clothes girls iron the parts which are afterwards restitched together.

There is a small laboratory attached to the works and a chemist who has a doctor's degree has charge of this laboratory and the technical part of the business. The whole works struck the writer as being run on very modern lines, no hesitation being made in adopting new ideas.

Dry cleaning and dyeing is already in an advanced state of development and from its very nature has to progress faster than any other branch of dyeing.

Moreover, no branch of dyeing requires more skill so that it is certain that only those employing the best technical men can hope to succeed in it. The dyer must know the nature of the material he is treating and the goods sent in vary from artificial silk to india rubber. He must consider the after use to which the goods will be put and must select his colors accordingly; and he must, among other things, be well informed concerning the properties of the best colors on the market.—S. H. Higgins, M. Sc. in *The Dyer and Calico Printer*.

Dyeing Kemps.

Kemps are imperfect fibres met with in wool. The characteristics of an ordinary kemp fibre is a hair of dead silvery white, thicker and shorter than the good wool. Kemp fibres do not seem to differ considerably in their chemical composition from the good or true wool fibres, but possess no absorbent power, thus resisting either entirely, or partly, the entrance of dye-stuffs, in the latter case producing a different shade from that imparted to the good fibres of the same lot, hence kemp fibres will be readily detected in dyed lots of wool, yarn or fabrics.

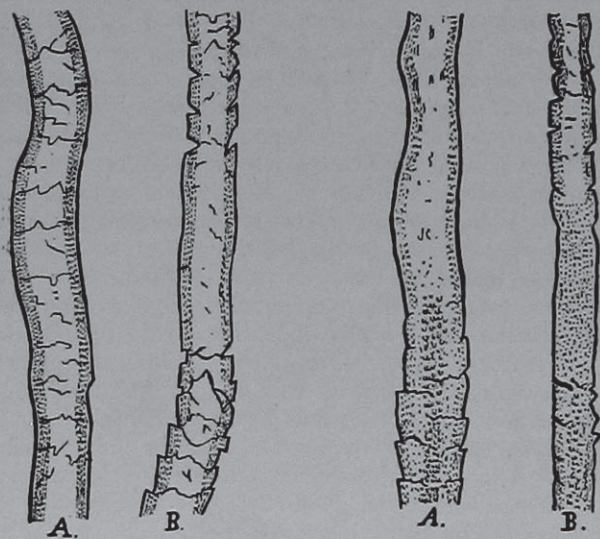

FIG. 1.

FIG. 2.

The accompanying illustrations Figs. 1 and 2, are given to illustrate various degrees of these Kempy fibres. Fig. 1, A, is a fibre in which the kempy structure continues throughout the entire fibre, and which looks more or less like a glass rod, yet has short and faint transverse lines which indicate the margins of the scales. When the change is a complete one, even the application of caustic alkali fails to bring out the lamination of the scales with any degree of distinctness. In Fig. 1, B, a fibre is shown in which the change from true wool to kemp is only partial. The lower portion of the fibre shows wool structure (the scales being distinctly visible), whereas the central portion of the fibre shows kemp structure (having the scales closely attached to the body of the fibre, giving the latter the usual ivory-like, smooth, horny appearance). The upper portion of the fibre leans again towards wool structure. Both illustrations,

Figs. 1, A and B, are representations of fibres seen by reflected light. In Figs. 2, A and B, illustrations are given of kemp fibres seen by transmitted light. In Fig. 2, A, a kempy fibre is seen with transmitted light and where we see again a gradual passage of wool structure into kemp. In this case, with transmitted light, the kempy part retains almost the same transparency as the wool, but exhibits none of the interior arrangement of cells. The fibre shown in Fig. 2, B, is practically kemp structure.

In the wild breeds of sheep kemp is plentiful and appears to be part of their nature; and in domestic sheep it may be looked upon as an inherent tendency to reversion to the original and native type of the animal. It is sometimes found in the finest grades of wool as well as in the coarsest. In the fine wool sheep, kemp occurs most frequently in the neck of the fleece and on the legs, whereas in the coarse woolled sheep, it may be found on any part, especially if there is a lack of trueness in the blood. The presence of kemp in a fleece greatly depreciates the value of the lot of wool, and a buyer is always cautious to ascertain if wools contain them.

To dye kemps, the smooth, horny covering encasing the cortical substance of such fibres must be broken, so that the dye can penetrate into the fibre proper.

We herewith quote from "The Dyer and Calico Printer," an account of some experiments undertaken by Mr. J. Hughes, with a view to ascertain in what manner this dyeing of Kemp may best be done.

"Oxidation by electrical means has come to the front as a method of oxidising both inorganic and organic bodies. It can be kept up continuously for an indefinite period, and is usually efficacious. In the case of kemps, however, a singular lack of effect is noticed. It is very evident that treatment is required with a chemical which has an affinity for the constituents of the kemps, and at the same time has a certain amount of oxidising power.

Dilute nitric acid: This, used at the boil for 15 minutes, has a marked effect upon kemps, examination under the microscope showing that the epithelial covering is broken up. The effect, however, is irregular, and moreover the yellow tinge given by the acid to the wool would prevent the use of this reagent except for dark shades.

Bleaching powder: One to two per cent. of this gives Kemps a great attraction for dyes, but the effect is very irregular, some of the kemps still remaining white.

Sodium hypobromite: A good result is obtained by using $\frac{3}{4}$ per cent. and boiling for a quarter of an hour. The kemps will dye even darker than wool that has been similarly treated, but there is the objectionable harshness present, common to all wool that has been treated with hypochlorite or hypobromite.

Potassium chlorate: This slightly increases the affinity for dyes.

Potassium persulphate: In strong acid solution, this gives good full shades, but the results are never constant.

(Continued on page xi.)

Klauder-Weldon Dyeing Machines

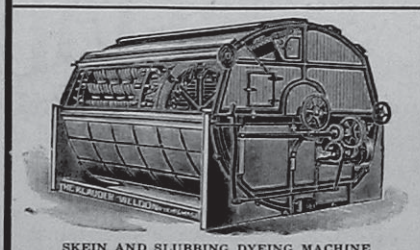

SKEIN AND SLUBBING DYEING MACHINE

HUDDERSFIELD, ENG.
AMSTERDAM, N. Y.

Are sold on two months' trial. You are therefore taking no risk. The saving in labor alone will pay for their cost in from 6 to 12 months, according to capacity.

For dyeing Worsted, Woolen, Cotton and Silk Skeins, Slubbing, Raw Cotton, Wool, Waste, Rags, Knit Goods, Shirts, Drawers, Hosiery, Tapes, etc.

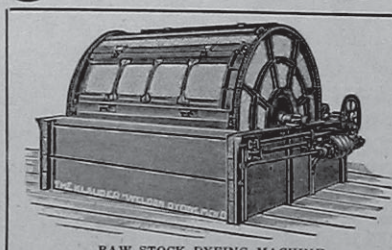

RAW STOCK DYEING MACHINE

O. A. ROBBINS
Charlotte, N. C., Southern Agent

Klauder-Weldon Dyeing Machine Co.

TESTING OF CHEMICALS AND SUPPLIES IN TEXTILE MILLS AND DYE WORKS.

(Continued from page 123.)

The separation of precipitates from the liquids with which they are mixed is effected either by *decantation* or by *filtration*.

DECANTATION is used when the precipitate has a much greater density than the liquid in which it is contained. The vessel in which the precipitate is to be collected or washed, by decantation, should have an area very small compared to its height. In decantation, the precipitate is allowed to settle until the liquid above it (known as the *supernatant* liquid) is perfectly clear. The clear liquid may be poured out carefully or it may be siphoned off. The vessel containing the precipitate is then filled with water, the precipitate is stirred with a glass rod, allowed to settle, and the water drawn off as before. Decantation usually precedes filtration; but some precipitates do not settle out, so that decantation cannot be used in separating them from their solutions, filtration must be resorted to.

FILTRATION is a mechanical mode of separating the liquid from the precipitate, by passing the solution containing the precipitate through unsized paper (known as filter paper), the precipitate being retained on the filter, the solution passes through. Filtration is convenient for quantitative analysis, because the precipitate when it is on the filter can be readily transferred to the drying bath or crucible, in which it can be weighed.

The paper for filtering should be as free as possible from mineral substance; it should be thin and compact in structure and should allow water to pass rapidly through it. The filter paper is circular in shape, with a diameter of from two to ten inches.

The filter is made by folding these circular discs, first in half, then folding at right angles to the diameter. This is opened and fitted into a funnel. When fitted in the funnel, the filter should have a thickness of three sheets of paper for half its surface and a thickness of one sheet of paper for the other half of its surface. The filter should fit snugly into the funnel, and when it is moistened, there should be no air spaces between the glass and the paper. The filter should never extend to the rim of the funnel.

The vessel into which a liquid is to be filtered must always be large enough to hold considerably more than the solution that is to be filtered, and the spout of the funnel must rest against its side so as to prevent splashing.

In quantitative experiments, any loss in transferring the precipitate on to the filter must be guarded against. For this purpose, a glass rod should be held at the spout of the beaker so as to direct the stream of the liquid upon the thick folded side of the filter, and prevent it from piercing the paper.

Sometimes a precipitate may be so fine that it will pass through the pores of the filter; this difficulty may be overcome by using a double filter, *i. e.*, two sheets of filter paper instead of one, or by allowing the solution to stand a little while before filtering.

WASHING PRECIPITATES: The precipitate on the filter always retains some of the liquid with which it was mixed before filtering. This liquid generally contains, in solution, substances which are not wanted with the precipitate. These substances are removed by washing. Washing may be partly effected by decantation, as has been described; the final washing being concluded on the filter by adding water until the filtration no longer shows any indication of dissolved

I CAN HELP MANUFACTURERS TO CUT DOWN THEIR FUEL BILLS

I have installed at my laboratories a complete, perfect equipment for the chemical analysis of coals, and the determination of their heat producing and other qualities. Write me for information.

FREDERICK J. MAYWALD, F. C. S., Consulting Chemist, 91 Pine Street, NEW YORK CITY

PROCTOR DRYERS FIRE PROOF BUILT OF METAL

Formerly the "Cyclone"

YARN DRYERS
COTTON STOCK DRYERS
WOOL DRYERS
HOSIERY DRYERS
CLOTH DRYERS
CARBONIZING OUTFITS
YARN SCOURING MACHINES
VENTILATING FANS

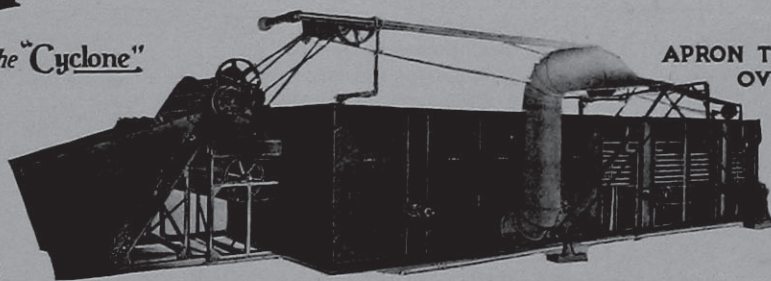

Proctor Dryer Panels removed from end

APRON TROUBLES
OVERCOME BY

The INTERLOCKING
CHAIN CONVEYOR

"It needs no adjustment"

THE PHILA. TEXTILE
MACHINERY CO.

HANCOCK and SOMERSET STS.
PHILADELPHIA PA.

PATENTS \$55

INCLUDING EVERYTHING DON'T PAY MORE

\$5 starts your case
Send for free book

Keystone Law and Patent Co.

1325 Arch Street

PHILADELPHIA, PA.

CURTIS & MARBLE MACHINE CO.

MANUFACTURERS OF

WOOL BURREING, PICKING AND MIXING MACHINERY

CLOTH-FINISHING MACHINERY

FOR COTTON, WOOLEN, WORSTED AND FELT GOODS,
PLUSHES, VELVETS, CORDUROYS, CARPETS,
RUGS, MATS, ETC.

SINGLE OR DOUBLE WOOLEN SHEARING MACHINES
WITH PLAIN OR LIST-SAVING RESTS.

Successors to

ATLAS FOUNDRY AND MACHINE CO., Irvington, N. J.,
and MILLER PRESS AND MACHINE CO., Woonsocket, R. I.

Also to the Shearing Machine Department of
WOONSOCKET NAPPING MACHINERY CO.

WORCESTER, MASS.

substances, either when evaporated on a platinum foil, or when tested with an appropriate reagent.

The best way to wash the precipitate when on the filter is, fill up the filter nearly to the edge of the paper with distilled water, then allow all the water to drain off completely before adding fresh water. This should be done three or four times, then the filtrate may be tested for any dissolved substance. If none is found the washing is completed, but if a trace of dissolved substance is found, the washing must be continued. The wash bottle is the most convenient apparatus to use for washing a precipitate. Such a wash bottle consists of a flask, provided with a rubber stopper having two holes, into each of which snugly fits a glass tube. Both tubes are bent. One of them reaches nearly to the bottom of the flask, the other end terminating in a point. The other tube extends just below the stopper. By blowing into the latter, a fine stream of water will come out of the pointed end of the other tube, previously mentioned, and which stream can be directed to any point on the filter, for washing purposes. Care should be taken that the water does not come out with too great a force, or else it will splash out some of the precipitate. To simplify matters men-

tioned, this wash bottle works on the same principle as the common spraying outfits sold in drug stores.

PREPARING A SAMPLE FOR TESTING: When a substance is to be analyzed, the first step in the analysis is the making up of a sample. This operation is more important than most people realize. If the sample is not a good average one, the analysis of it, no matter how carefully it is worked out, is practically worthless; because the analysis of a poor sample does not give the analysis of the material to be tested. The first thing to be considered is the size of the sample; as a general rule it may be stated that this depends upon the amount of material under consideration; for a large lot a large sample is taken, for a small lot a small sample may answer, *i. e.*, if a test is to be made of a hundred-pound lot of a chemical or dye, one pound will be sufficient for a sample. The sample is selected by taking portions of it from various parts of the mass. If possible, mix the mass before sampling. The sample is then thoroughly mixed and a small portion only has to be taken for the analysis. If parts of the lot of material to be tested have a different appearance, *i. e.*, one part more powdery than another, or one part having a little different color than another, we must take a portion of these different parts to make up the sample.

(To be continued.)

NEW PUBLICATION.

We have just received from Heywood & Co., Ltd., 150 Holborn, E. C., London, England, "*Aniline Black*," by E. Noelting and A. Lehne, translated by Arthur Morris, Editor of the "Dyer & Calico Printer."

This book *must* prove very valuable to the dyer and printer, as it completely covers the subject of dyeing and printing with Aniline Black.

Both Mr. Noelting and Mr. Lehne are recognized experts in their line; the first being the Director of the Mulhouse Chemical School, and the latter the President of Section of the German Patent Office.

The back pages of the book contain 45 most beautiful samples of dyeings and resist prints. The price of the book is \$4 net, and can be obtained from our office or any Bookstore handling Technical Works.

CIBA DYES

CIBA BLUE CIBA BORDEAUX
CIBA VIOLET CIBA SCARLET
CIBA RED CIBA HELIOTROPE
CIBANON YELLOW, ORANGE, BROWN

*Vat Dyes for Cotton Dyeing and Printing—also
 for Wool and Silk. Fast to Light, Chlorine and Washing.*

Made by SOCIETY of CHEMICAL INDUSTRY, BASLE

A. Klipstein & Co., : New York, : American Agents

MILL NEWS

Philadelphia, Pa. The Firth & Foster Co., Philadelphia's most important Public Dyeing and Finishing plant, in fact, the largest and most important plant of that kind in this country, is running to its fullest capacity, with several of its Departments running on over time. Mr. Jules A. Kerlé is the Business Manager of the Concern, with Messrs. Albert Foster and Edward Firth at the helm, looking after the practical work in their Mills; Mr. John H. Foster, one of the founders, being the genial President of this enterprising Concern. To accommodate the ever increasing business with New York Commission Houses, they retain offices at the Silk Exchange Building.

Messrs. John Scanlin & Son, the proprietors of the Howard Mills, are running again on full time; some of their looms operating on Union Worsted Men's Wear for the Glasgow Mills, of which A. H. Burnham is the energetic Superintendent.

It is rumored that the Wallace Wilson Hosiery Company, Inc., will erect a modern mill structure, 311 feet by 46 feet, including a dye house and everything necessary for the manufacture of the best hosiery.

Bridgeport, Pa. A large addition will be built to the James Lees & Co.'s mills, carpet yarn manufacturers, giving employment to several hundred more hands.

Easton, Pa. The erection of the largest addition to the Silk Works of Herman Simon has been commenced; the building being 175 feet long, 150 feet wide and two stories high, and will be used for installing broad silk looms.

Hamburg, Pa. The Hamburg Silk Company has been purchased by the Jefferson Silk Co., of West New York, N. J. Improvements will be made at once and operations resumed.

Honesdale, Pa. The American Knitting Company will erect a store house 105 feet long, adjacent to the present plant of the company.

Lehigh, Pa. Walter Drumheller and Charles A. Hauck have started the "Carbon Knitting Mill Co." The plant is located on South Second Street; the machinery has arrived.

Lewiston, Pa. Building has been commenced for the erection of the new silk mill, a branch of the Susquehanna Silk Mill Co., of Sunbury. The new mill will give employment to about 350 hands.

Siegfried, Pa. The Central Silk Manufacturing Co. has decided to build an addition to the plant. Work will be started as soon as possible and it is expected that the building will be finished by September 1, and will be equipped with 150 looms. Broad silk is manufactured exclusively and the firm has always found a ready sale for all its goods. The new addition will be erected to meet the increasing demand. Herman Feldhege is the superintendent of the plant and he is an expert on the manufacture of broad silk.

Spring Forge, Pa. The capacity of the Pennsylvania Knitting Co. is doubled, the dyeing and finishing departments having been enlarged at the same time. About 40 new knitting machines are installed.

Topton, Pa. It is rumored that the Hartley Silk Manufacturing Co. is to enlarge their plant.

Amsterdam, N. Y. The Shuttleworth Bros. Co. will erect a new mill, 20 by 65 feet, six stories high.

Binghamton, N. Y. A new concern incorporated as the Rossville Silk Mills Co., has taken over the Binghamton Silk Mills. In addition to the present equipment of 107 broad looms, the Rossville Silk Mills Co., will enlarge the plant by 150 new looms. An option has been secured on an additional building. William H. Boydell, who ranks among the highest in the art of silk manufacturing, is the Superintendent. The output is, dress silks of the highest quality, tie silks and mufflers.

Herkimer, N. Y. The Royal Gem Knitting Company has bought the Clark mill property on King street, and will take possession of it August 1.

North Tonawanda, N. Y. It is rumored that one of the silk mills from Gloversville has taken an option on the Webb property on Ellicott Creek, where it will erect a large silk mill.

Oneonta, N. Y. J. W. Warburton, who for seven years has been superintendent of the A. & B. silk mill at Coatesville, Pa., is here, succeeding H. E. Davies, who came temporarily here from Paterson to take charge of this branch mill of the Paragon Silk Co.

Sidney, N. Y. The Sidney Silk Mill has been purchased by a Goshen party, and the mill will soon be running.

Adams, Mass. Thirty new Jacquard Machines have been installed by the Renfrew Manufacturing Company in its No. 5 mill. The whole mill is to be devoted to Jacquard work.

Boston, Mass. The directors of the Ipswich Mills have decided to increase the capital stock from \$400,000 to \$500,000. The proceeds of the new stock will be used to acquire the Gilmanon Mills.

Fall River, Mass. New cards will replace the old ones in the Osborn Mills, No. 1; their Mill No. 2 having been renovated some time ago.

The stockholders of the Flint Mill have voted to double the capital stock and to build another 50,000 spindle mill.

Holyoke, Mass. The Germania Mills Co. have secured the necessary ground from the city to erect another woolen mill, to cost \$100,000. The Germania Company operates also several other mills in Rhode Island. There are already under way in Holyoke factory and mill construction to the total value of \$1,500,000.

Jefferson, Mass. Merriam B. Conolly has been engaged as Boss Carder of the Eagle Lake Woolen Company.

Lawrence, Mass. The new worsted mill of the Arlington Mills will contain 40,000 spindles and produce about 80,000 pounds of yarn per week, giving employment to about 1,200 operatives.

Lowell, Mass. The Pentucket Narrow Fabric Co. has filed notice of its intention to triplicate its capital stock, in order to be able to expand its plant to meet the demands for their products.

Millbury, Mass. The Millbury Worsted Company of this town and Uxbridge will shortly have their new mill, located in the center of the town, in operation.

New Bedford, Mass. Construction has been commenced on the New Bedford Cotton Mill, Coffin avenue and Church street.

The City Manufacturing Company is planning to build an addition to the picker room, and build a third story on the present two-story building.

The Taber Mill Corporation intends to erect a brick addition 60 by 100 feet to their picker room.

It is rumored that a new mill corporation, known as the Holmes Mill, has been organized. A 60,000 spindle plant located in the southern portion of the city, David street and French avenue, is contemplated. Mr. Charles M. Holmes, the present Agent of the Mahomet Mills, is mentioned as the Agent and Treasurer of the new concern.

The new Pierce mill will be located just south of the Beacon mill, west of

(Continued on page xviii)

BOOKS ON TEXTILE SUBJECTS.

- Wool Dyeing (Part 1)**, by W. M. Gardner. Price \$2.00.
TABLE OF CONTENTS: Fibre, Scouring, Bleaching, Water, Mordants, Assistants and other Chemicals.
- Wool Dyeing (Part 2)**, by Gardner and Knaggs. \$3.00.
TABLE OF CONTENTS: Classification of Coloring Matters; Natural Dyestuffs: Logwood, Redwoods, Madder, Cochineal, Kermes and Lac-dye, Orchil; Cudbear and Allied Coloring Matters, Yellow-Dyes, Indigo; Artificial Dyestuffs: Classification of Coal-tar Dyes, Artificial Mordant Dyes, Acid Mordant Dyes, Acid Dyes, Direct Cotton Dyes Suitable for Wool, Basic Dyes, Dyes Applied by Oxidation, Reduction and other Special Processes, Metallic Dyes, Methods of Dyeing Wool in Various Forms, Suitability of Dyes for Different Classes of Work, The Theory of Wool Dyeing.
- The Dyeing of Cotton Fabrics**, by F. Beech. Price \$3.00.
TABLE OF CONTENTS: Fibre; Action of Alkalies, Acids and Oxidising Agents; Bleaching; Dyeing Machinery and Manipulations; Principles and Practice of Cotton Dyeing; Dyeing Unions, Cotton-Wool, Cotton-Silk; Washing, Soaping, Drying; Testing Color; Experimental Dyeing and Comparative Dye Testing.
- Silk Dyeing Printing and Finishing**, by G. H. Hurst. Price \$2.00.
TABLE OF CONTENTS: Fibres; Boiling Off; Bleaching; Dyeing Blacks and Fancy Colors; Weighing; Dyeing Mixed Fabrics; Printing; Dyeing and Finishing Machinery and Processes.
- Dyeing of Textile Fabrics**, by Hummel and Hasluck. Price \$2.00.
Three Volumes Bound in One.
Vol. 1: Textile Fabrics and Their Preparation for Dyeing.
Vol. 2: Coloring Matters for Dyeing Textile Fabrics.
Vol. 3: Mordants, Methods and Machines used in Dyeing.
- Wool, Cotton, Silk; Fibre to Finished Fabric**, by Posselt. Price \$7.50.
TABLE OF CONTENTS: Raw Materials; Preparatory Processes: Carding, Drawing, Spinning and Twisting; Winding, Warping; Weaving Machinery and Supplies; Knitting, Processes and Machinery; Dyeing, Bleaching, Mercerizing, Processes and Machinery; Finishing, Processes and Machinery; Heat, Power and Transmission.
- Color in Woven Design**, by R. Beaumont. Price \$7.50.
This work contains on 32 plates 126 colored illustrations of Diagrams illustrating the Mixing of Colors; Fancy Yarns, Fancy Cassimeres, Worsteds, Trouserines, Coatings, Suitings, Ladies Dress Goods, Cloakings, Fancy Cotton and Silk Fabrics. Besides said 126 colored illustrations, the work contains 203 illustrations, in black and white, of Weaves and Color-effects in Fabrics, etc., accompanied by 440 pages of reading matter.
- Chemistry of Dye-Stuffs**, by G. von Georgievics. Price \$4.50.
A textbook presenting to the student in as condensed a form as possible the extremely wide domain of the modern chemistry of dye-stuffs; bringing into prominence all the relations known to subsist between the various dyes and groups of dyes, as well as the connection between color and constitution, since the proper appreciation of these relations forms the main object of color chemistry.
- The Jacquard Machine**, by E. A. Posselt. Price \$3.00.
TABLE OF CONTENTS: Different parts of the Jacquard Machine and its Method of Operation; The Jacquard Harness; The Comberboard; Tying up of Jacquard Harnesses for all kinds of Fabrics, Modifications of the Single Lift Machine; Stamping, Lacing and Repeating of Jacquard Cards; Practical Hints on Jacquard Designing.
- Testing of Yarns and Textile Fabrics**, by J. Herzfeld. Price \$3.50.
A Guide for the Manufacturer and Large Purchaser, who observe definite specifications to insure standard material and workmanship; also giving a collection of tests, both of physical and of chemical nature.
- Woolen Spinning**, by C. Vickerman. Price \$1.75.
TABLE OF CONTENTS: Fibre, Supply, Sorting, Scouring and Drying, Bleaching and Extracting, Dyeing, Burring, Mixing and Oiling, Carding, Spinning, The Mule, Miscellaneous.
- Wool Combing**, by H. Priestman. Price \$1.50.
TABLE OF CONTENTS: Fibre, Washing, Water, Carding, Preparing, Intermediate Processes, Combing, Finishing, Tops and Top Testing.
- Silk Throwing and Waste Silk Spinning**, by H. Rayner. Price \$2.50.
A Treatise on the Principles of Silk Throwing and Waste Silk Spinning, with Illustrations and Descriptions of the Machinery used.
- Textile Calculations**, by E. A. Posselt. Price \$2.00.
A Complete Guide to Calculations Relating to the Construction of All Kinds of Yarns, Fabrics, and the Analysis of Cloth.
- Cotton Spinning**, by T. Thornley. 3 Volumes. Price \$6.50.
A Complete Self-Instructor (with Questions and Answers) on this subject, treating machinery and processes as used abroad.

The above books, as well as any other books on Textile Subjects, no matter where published, sent charges prepaid. Remittances should be made by Check or Money Order, or in Registered Letters. Not responsible for money lost, when otherwise sent.

TEXTILE PUBLISHING COMPANY
Lambert and Berks Sts. PHILADELPHIA, PA.

WEIMAR BROTHERS
MANUFACTURERS OF
Tapes, Bindings and Narrow Fabrics
2046-48 AMBER STREET
PHILADELPHIA

WHEN QUALITY COUNTS WE GET THE ORDER



Cuts in this Journal are a sample of our work.

ESTABLISHED 1869 INCORPORATED 1908

The Whitaker Reed Co.
MANUFACTURERS OF
LOOM REEDS OF ALL KINDS
"Royal" Ring Travelers, Mill Wire Goods and Heddles
Worcester, - - Mass.

Cost and Accounting Systems
Periodical or Casual Audits

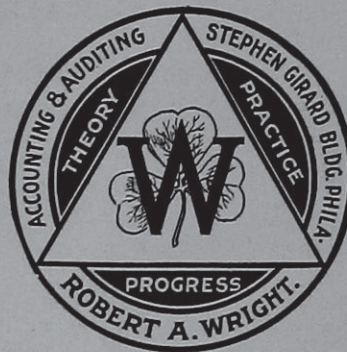

Consultations and
General Accounting

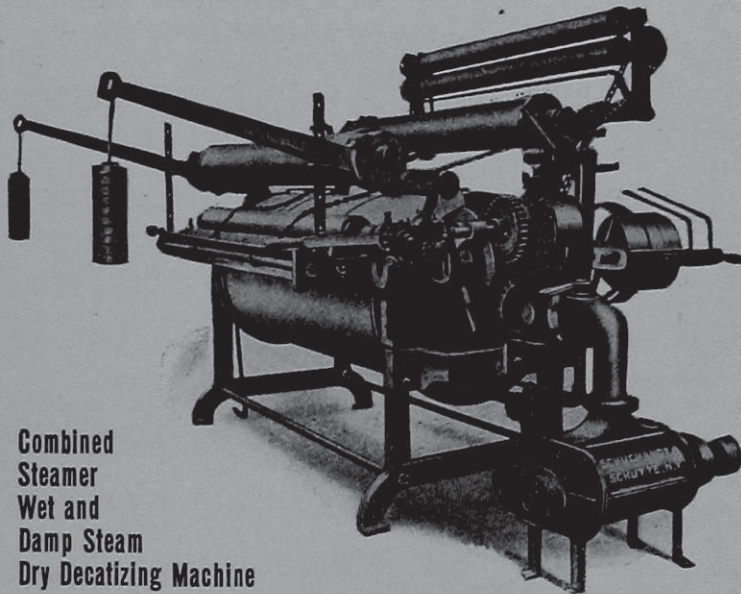

Combined
Steamer
Wet and
Damp Steam
Dry Decatizing Machine

Carbonizing, Dyeing and
Mercerizing Machinery

Examination Tables
(3 Styles)

Schuchardt & Schütte

90 West St., NEW YORK

Woolen and Worsted
Finishing Machinery

New Spinning
Frame

MANUFACTURERS
— OF —
ANTHRACINE



COAL TAR
PRODUCTS
—
ANILINES

DOUBLE SERVICE — — LASTS TWICE THE BEST PACKING MADE

GIVE US A TRIAL

WE HAVE THE GOODS

Everything in BELTING, HOSE, VALVES, RUBBER GOODS

DOUBLE SERVICE PACKING CO., 208 CHESTNUT ST., PHILA.

Purchase street and north of Sawyer street.

It is reported that Harding, Whitman & Co. will erect a new mill at the north end of the Willis property, just west of the Nonquit Mill.

North Brookfield, Mass. The Oxford Linen Mills have awarded contracts for the erection of three new reinforced concrete buildings, costing about \$150,000, with a similar amount to be invested in machinery.

Pittsfield, Mass. The Musgrove Knitting Co. has purchased the large brick mill of the Pittsfield Steam Power Co. The building is three stories high, 200 by 65 feet, the first floor being at present occupied by the new purchasers and the second floor by the General Electric Co.

Taunton, Mass. The Corr Manufac-

turing Co., manufacturers of plain and fancy cotton goods, of which Mr. R. J. Belcher is the successful Superintendent, will double its present capacity in order to meet the immense demands for their Products, and which refers to the finer grades of cotton cloth.

Mr. A. C. Marsh is the new Superintendent of the Taunton Knitting Company's Mill on Ingell street.

Williamstown, Mass. It is expected that the Williamstown Manufacturing Company's Mills, located at the station, will commence within a few days to run full time.

Hills Grove, R. I. It is rumored that the Elizabeth Mill Company intends to erect a three-story addition 74 feet long to its plant.

Providence, R. I. The plant of the

Queen Dyeing Company has been sold to the United States Finishing Company, making this the seventh plant that this Company has absorbed.

Valley Falls, R. I. The headquarters of the Tilton Mills, recently incorporated under the laws of New York State, with a capital of \$500,000, will be in the mill at Valley Falls now occupied by the Naushon Company. The principal products of the new concern will be of cotton, and silk and cotton, and will be sold exclusively to the converting trade.

Westerly, R. I. The Westerly Narrow Fabric Co. has awarded a contract for the construction of a large addition to the plant which it recently occupied on Beach street and expects to have its entire facilities in operation by Sep-



We are
prepared
to prove that
Peroxide of
Sodium for

Bleaching
animal & vegetable
fibres
or their mixtures
is the best.

Rosessler & Hasslacher
Chemical Co.
New York

tember 1. The new buildings include a weave shed 157 by 123 feet.

Woonsocket, R. I. The Paragon Worsted Company will locate here. The incorporators are Fred E. Warren, of New York, and Frederic Dulude and Joseph C. Mailloux, of Woonsocket. The capital stock is placed at \$100,000. It is the intention of the Company to engage in the worsted and woolen business. They are negotiating for the purchase of the Sayles & Prendergast plant on South Main street.

Norwich, Conn. Mr. William G. Henderson, Agent of the Falls Co., will also assume the management of the Shetucket Company July 1st. Mr. W. I. Woodward, the present Agent of that concern, will then resign.

South Manchester, Conn. This town is enjoying unusual prosperity at the present time, business prospects for the future are bright, Messrs. Cheney Brothers' silk plant, which employs about 4,000 people, receiving orders that will keep them busy for the next year.

Biddeford, Me. The Pepperell Manufacturing Co. contemplates the erection of a new weave shed to accommodate about 350 broad looms.

Oakland, Me. The property of the Oakland Woolen Company was sold at auction to satisfy a claim of \$5,000 held by Arthur B. Collier, who was injured while working in the mill, losing his right arm. He brought suit and was given a verdict of \$5,000. There was but one bid made by the lawyer of Mr. Collier and the mill was sold to him for \$4,100. The property is subject to a mortgage of \$60,000 held by

the Augusta Trust Company, of Augusta.

Laconia, N. H. William C. Marshall and J. P. Morin have sold their plant to the Belknap Mills Company, of which J. P. Morin is the president. It is to remain a knit goods mill.

Tilton, N. H. Mr. Arthur S. Brown has purchased the controlling interest in the Tilton Mills. Mr. Brown will continue the manufacture of woolen goods at the mills here, which are now running night and day, and it is reported may shortly enlarge the plant.

Buena Vista, Va. The woolen mills here have been sold by the American Mills Company to Emmanuel Gerli, of New York, who will convert the plant into a silk mill.

Danville, Va. The Dan River Power and Manufacturing Co., of which Mr. Geo. W. Robertson is the successful Superintendent, has awarded the contract for their Cotton Mill No. 3 and Cloth Mill No. 2. The former will be 300 feet wide, 550 feet long and four stories high. This will make the Dan River Power and Manufacturing Co. one of the most prominent concerns in the South.

Winchester, Va. The Virginia Woolen Co., of this place, and of which Mr. F. S. Hunt is the successful Superintendent, is to double its capacity. The product of the mill is flannels, cassimeres and chevots.

Chattanooga, Tenn. The Davis Hosiery Mills will build an addition two stories high, with basement, 50 by 100 feet, of brick, and equip it with knitting machinery.

Knoxville, Tenn. William T. Lang, a most prominent Southern Textile man, and Associates, have chartered the Castle Cotton Mills, with a capital stock of \$1,000,000.

Lebanon, Tenn. The Lebanon Woolen Mills Company is now an assured fact. H. M. Freeman, the Superintendent, has provided for the erection of a two-story 72 by 174 foot building, with an Annex 40 by 50 feet; for boiler room and for the wet finishing department. Two sets of cards, 1,440 spindles, 30 broad looms, with necessary auxiliary machinery, will form the equipment. They will manufacture Woolen Blankets.

Memphis, Tenn. The Memphis Bag Company, a Branch of the Jackson Fibre Co., M. M. Bosworth Mgr., and which has been operating a plant here for years on the manufacture of Jute bags, will begin shortly the erection of a new plant for the manufacture of cotton and burlap bags. The new building will be five stories high and cost about \$50,000.

Rockwood, Tenn. The Rockwood Mills will increase capital stock by \$25,000 and build a 60 by 200-foot addition, to be equipped with machinery for increasing the company's daily output to 1,000 dozen pairs of hosiery.

Bladenboro, N. C. Bridger Brothers of this place are the promoters of a Cotton Mill to be located on the S. A. L. Railroad; if successful making it the first industry introduced here.

Charlotte, N. C. The Louise Mills have installed 208 new looms, taking the place of 150 old style looms; they

(Continued on 3d cover)



"HURRICANE" DRYERS

For Wool, Cotton Stock, Yarn, Knit Goods, Etc.

Belt-Driven **FANS** Motor-Driven

Power Screw **PRESSES** Hydraulic

WRITE FOR CATALOGUES

THE PHILADELPHIA DRYING MACHINERY CO.,
6721 GERMANTOWN AVE., PHILADELPHIA, PA.

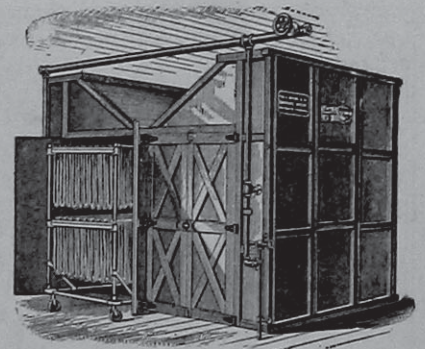

Hand Book on **Knitting**

The Process; Modern Machinery and Devices; New Fabric Structures; Dyeing, Drying, Bleaching and Finishing, Processes and Machinery.

Edited by E. A. POSSELT; Richly Illustrated; Bound in Cloth; Price One Dollar, Ready for Delivery about November.

Boston.

Providence.

Philadelphia.

Chicago.

Charlotte.

Albany.

Toronto, Can.

FARBENFABRIKEN OF ELBERFELD CO.,

IMPORTERS OF ANILINE & ALIZARINE COLORS

P. O. Box 2162

NEW YORK

117 Hudson Street

New England Butt Co.

Providence, R. I.

Braiding Machinery, both American and German types, for making Dress Braids, Shoe and Corset Laces, Underwear, Trimmings, and all kinds of Round and Flat Braids.

WOONSOCKET YARN GASSING MACHINES

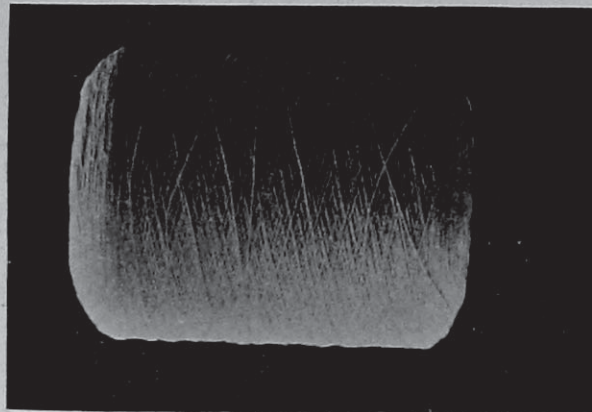

THE WIND

Woonsocket Machine & Press Company, **WOONSOCKET,**
R. I.

Builders of Cotton and Woolen Machinery

are also adding four new frames, and a new warper.

These looms are "Draper Looms," it is reported that more will be added.

The Kerr Bleachery and Finishing Works will be in operation next month, its building, four stories high, 64 by 206 feet, being completed. Engine and Boiler, as well as Singeing, Dyeing, Napping and Bleaching Machinery is arriving. The daily capacity of the plant will be ten tons.

Forest City, N. C. A company of which G. P. Reid is the President, has been organized, for the purpose of building a Knitting Mill.

Franklinville, N. C. The Franklinville Cotton Mills are putting in a new water wheel made by S. Morgan Smith & Co., of York, Pa.

Gaffney, S. C. The Globe Manufacturing Co. has awarded contract for the construction of its addition to enable them to double its capacity. The company has for this purpose increased its capital stock from \$75,000 to \$200,000.

Henrietta, N. C. The machinery in the old part of this mill is being taken out and replaced by improved machinery, requiring the plant during the change to run up to 9 P. M.

High Point, N. C. Stehli & Co.'s silk mill at this place will be enlarged for the fourth time; this time it will be a 75-foot addition, giving employment to a large number of girls. This is one of the most complete and modern silk plants in the South.

Hillsboro, N. C. The Belle-Vue Manufacturing Company is changing over from a knitting mill to a weaving mill, having for this reason begun the erection of a weave shed 190 feet by 75 feet as an addition to the plant, for the accommodation of 200 Crompton & Knowles looms. They will manufacture fancy gingham.

Landis, N. C. It is reported that a new cotton mill is to be erected here. Mr. C. J. Deal, the manager of the Linn Mill, is the principal owner of this new concern.

Lincolnton, N. C. Work of breaking ground for the Saxony Spinning Company's new 10,000 spindle mill has begun. It is to be a yarn mill.

A representative of Stuart W. Cramer, of Charlotte and Atlanta, the well-known mill engineer, is in town laying out the ground for Edgar Love's new mill. Besides the mill buildings, about 30 cottages will be built to accommodate help.

Monroe, N. C. The Icemorlee Cotton Mills Co. have decided to build its 5,000-spindle addition.

Rutherfordton, N. C. The Levi Cotton Mills Co., it is reported, will double its capacity.

St. Paul, N. C. The new cotton mill at St. Paul is now running, all the machinery having been installed.

Sanford, N. C. It is rumored that a knitting mill will be erected here by Mr. W. A. Ellington.

Warrenton, N. C. Mr. T. D. Peck, a wealthy cotton mill man of Massachusetts, offered to put up \$60,000 for a new cotton mill, provided local capitalists would raise \$40,000 additional. The amount was subscribed at once, ground donated and operations on building will be started at once.

Wendell, N. C. Experts from the Whitin Machine Works, and the Woonsocket Machine and Press Co., with a full force of hands, are pushing the erection of machinery in the Whitley Mfg. Co.

Aiken, S. C. It is rumored that W. D. McNeill, of Fayetteville, N. C., will erect a \$200,000 cotton mill, located on the Southern Railway, about a mile and a half from the city. There is an available water power of 250 horse power. The incorporators are Messrs J. Moseley, R. B. Carter, John A. Seigler, W. D. McNeill, Dr. Hastings and H. Wyman, Jr.

Anniston, S. C. The owners of the Adelaide Mills have begun the construction of an additional building that will, when completed and equipped, increase the capacity one-third, or to 10,000 spindles.

Camden, S. C. The Pine Creek Mfg. Co. has just installed 24 additional Crompton & Knowles looms. A new section was recently added to the warehouse, and now a second-story addition is being completed to the machine shop to provide room for a larger slashing department.

Gaffney, S. C. The Globe Mills have decided to increase its capital stock to \$300,000, for the purpose of providing funds for the additional buildings now being erected, as well as new machinery, etc.

Greenwood, S. C. The new machinery has been installed in the Greenwood Cotton Mills No. 1, and everything is giving complete satisfaction. All of the hands necessary to operate the mill have returned to the city.

Lancaster, S. C. It is rumored that Lancaster is to have another large cotton mill, financed by Colonel Leroy Springs, and which will probably be known as the Lancaster No. 2.

Laurens, S. C. The Laurens Cotton Mill is erecting an 80 foot extension to their mill, the same to be the same height as the old building—four stories—and is located at the south end of plant.

Rock Hill, S. C. The Aragon Cotton Mills have ordered 4,000 additional ring spindles from the Mason Machine Co.

Tucapau, S. C. The Tucapau Mills have installed twelve more cards; they manufacture print cloth.

Walterboro, S. C. G. W. Ethridge, formerly superintendent of the Greenwood Cotton Mills, will succeed J. T. McGregor, as superintendent of the Walterboro Cotton Mills.

Albany, Ga. The Albany Cotton Mills have organized with a capital stock of \$250,000, to operate a fine sheeting mill. The equipment will comprise 10,000 spindles and about 300 looms. Sheetings, ranging from 36 to 60 inches in width, will be manufactured.

Atlanta, Ga. The Fulton Bag and Cotton Mills will build a new picker house, 60 by 150 feet; two stories and basement.

Columbus, Ga. The Perkins Hosiery Mill has installed the new machinery in the addition built, thus doubling the capacity of the plant. The total expenditures for the new mill and new machinery it is reported amounts to about \$100,000.

Eatonton, Ga. The Eatonton Cotton Mills, recently purchased by J. W. Cannon, of Concord, N. C., will hereafter be known as the Imperial Cotton Mills. The product will be sheetings and drills.

Greensboro, Ga. It is reported that the Mary-Leila Cotton Mill, of Greensboro, contemplates increasing the capacity of its plant.

Lafayette, Ga. The slasher room of the Lafayette Cotton Mills has been completed and new machinery installed, increasing the output of the mill at least one-third.

Macon, Ga. Central City Hosiery Manufacturing Co. is the name of the new knitting mill quartered in the building formerly used as Grace Church. J. T. Hall is the manager of the concern.

Social Circle, Ga. The Social Circle Cotton Mill is doubling its capacity.

Alabama City, Ala. The Dwight Mfg. Co. has placed a new slasher in their No. 1 dressing room.

Birmingham, Ala. The Avondale Cotton Mill is installing a bleaching plant.

Eufaula, Ala. Three hundred and twenty Northrop looms have been ordered by the Cowhee Cotton Mills.

Merrimac, Tex. It is reported that the Merrimac Mercantile & Manufacturing Co. will establish a plant for the manufacture of artificial silk and horsehair.

Detroit, Mich. F. C. Conrath, of St. Paul, Minn., is in Detroit completing negotiations for the erection and equipment of a woolen mill to be erected at Royal Oak, for the Hudson Bay Blanket Company. Building and machinery to cost about \$150,000. The output of the company will be bed blankets and automobile robes.

Owosso, Mich. F. E. Sutfin has purchased the machinery of the Burnett Knitting Co. It is reported that Mr. Sutfin intends to continue to operate a plant of woolen hosiery.

Meridian, Miss. The Aldin Hosiery Mill, it is reported, will be in operation July 1, Mr. W. H. McClelland being the manager.

Sheboygan, Wis. The Hand Knit Hosiery Co., L. A. Bentz, manager, has increased its capital from \$25,000 to \$50,000, for the purpose of erecting a new mill, which will give employment to 100 hands, in place of the 40 now working there.

Ft. Wayne, Ind. Manufacturers of Ft. Wayne, who are employers of great numbers of girls, decided to forcefully back up their resolutions to oppose the bringing to this city of any factories requiring female labor, for the reason that girl labor is exhausted, and that 1,500 could easily find work now without any new mill locating here. Other manufacturers are backing a proposition of bringing woolen mills here, and the feeling is intense regarding the matter.

El Reno, Okla. D. C. Harris, of the Columbus (Miss.) Yarn & Textile Mills, contemplates building an underwear knitting mill, the daily capacity of which will be 125 dozen.

Hickasha, Okla. It is reported that the Hickasha Commercial Club is considering a proposition from L. M. Potts to erect a knitting mill to cost \$150,000.

EXPLANATIONS FOR THE CHART OF WEAVES ON "Textile Designing Simplified."

The object of this chart is to show how easy weaves for all classes of Textile Fabrics can be constructed; it will be a search light in the misty matters in the field of designing Textile Fabrics. Keep this chart of weaves for reference. Millions of new weaves can be obtained by it.

All weaves for Textile Fabrics have their foundation in Plain Twills and Satins.

PLAIN.—This weave and its sub-divisions are explained on the chart in the top row by 16 weaves, the sub-divisions covering common, fancy and figured Rib and Basket weaves.

TWILLS.—The foundation of constructing regular (45°) twills is shown by rows 2 and 3 with twenty six weaves, covering twill weaves all the way from 3 harness up to 13 harness.

The sub-divisions of twills are quoted next on the chart, being Broken twills, Skip twills, Corkscrews, Double twills, Drafting twills, Curved twills, Combination twills warp drafting, Combination twills filling drafting, 63° twills, 70° twills, Wide wale twills, Entwining twills, Checker-board twills, Pointed twills, Fancy twills, thus covering every sub-division of twill weaves possible to be made.

SATINS. are next shown, giving also their sub-divisions, viz: Double satins and Granites.

HOW TO PUT A BACK FILLING ON SINGLE CLOTH is shown below the satins by two examples, and at its right hand is quoted the principle of

HOW TO PUT A BACK WARP ON SINGLE CLOTH.

On the bottom line are given the four steps for:—

THE CONSTRUCTION OF DOUBLE CLOTH, 2 @ 1; and above the same one example, with the arrangement 1 @ 1.

THREE PLY CLOTH is shown by one example.

HOW TO BACK SINGLE CLOTH WITH ITS OWN WARP is shown by two examples.

WEAVES FOR SPECIAL FABRICS are quoted: Tricots (warp, filling and Jersey effects), Rib fabrics, Honeycombs, Imitation Gauze, Velveteen, Corduroy, Chinchillas Quilts Plush, Double-plush, Tapestry, Crape, Terry, Worsted coating stitching, Hucks, and Bedford cords

HOW TO WORK THIS CHART OF WEAVES.

CAPITAL LETTERS of references refer to the plain weave and its sub-divisions.

SMALL LETTERS of references refer to twills and their sub-divisions.

NUMERALS of references refer to satins and their sub-divisions.

Example.—How to ascertain the construction of the weave at the right hand top corner of the chart; being the figured rib weave marked C C? These two letters of reference mean that said figured rib weave is nothing else but the combination of the 2-harness 6 picks common rib weave warp effect C, and the 6 harness 2 picks common rib weave filling effect C'

Example.—The letter of reference c, underneath the first broken twill indicates that the same is obtained from the 1/2 4 harness twill c, (third weave on the second row; in other words, letter of references below each weave of any of the various sub-divisions refer always to the corresponding foundation weave.

Example.—Twills q, and o, are the foundation for the eight combination twills filling drafting, said common twills are drafted 1 @ 1, the different designs being obtained by means of different starting.

Example.—The wide wale twill 'w', has for its foundation the 63° twills, marked als, respectively 'w' and 'w', the latter two weaves have again for their foundation respectively the common twills marked t and w.

Example.—Granites marked 8 have for their foundation the 8-leaf satin, such as marked 12 the 12-leaf satin.

Example.—Backed by filling e 8, means the common 2/2 4-harness twill e, (fifth weave on second row) and the 8-leaf satin is used in the construction of this weave.

Example.—The complete design of double cloth, marked e 8 A, means that the common 2/2 4-harness twill (e), the common plain (A) and the 8-leaf satin (8) are used in the construction.

Example.—Rib fabric A, indicates that the plain weave forms the foundation

It will be easy to substitute different foundations in constructing weaves for heavy weights.

In reference to single cloth weaves we only want to indicate that by following rules shown in the chart, millions of new weaves can be made up from it.

"TEXTILE DESIGNING SIMPLIFIED."

Keep this chart on hand for reference. Only 14 weaves are given, yet they will guide you to make millions of new weaves.

