



# FOR WOOL AND SHODDY

Always  
Uniform  
and  
Reliable

★  
Once Used,  
Always Used



Unequalled  
Scouring Agents'  
and Fibre  
Lubricators  
★  
Do Not Gum  
Penetrating

SAMPLES GLADLY SENT ON REQUEST

WRITE US ABOUT YOUR NEEDS.

**BRADFORD OIL COMPANY, INC.**

**Lynn, Mass.**

*The Name  
and the  
Machine*

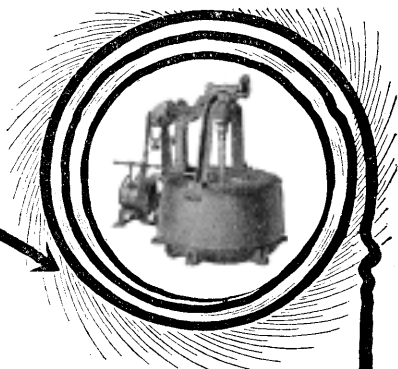

For 66 Years  
**"TOLHURST"**

has represented something more than a name. It has stood for supreme superiority in hydro-extractors.

Wherever hydro-extraction is practiced you will find TOLHURST WHIZZERS are universally used.

Built for motor, engineer countershaft drive, from below or above—center-slung, with open top, or self-balancing—they are adaptable for all purposes and conditions relating to general textile work—dyeing, bleaching and finishing.

**Tolhurst Machine Works**

Established 1852. TROY, N. Y.

New York Office: 111 Broadway

South. Rep., F. H. White, Realty Bldg., Charlotte, N. C.

West'n Rep., J. S. Gage, Hartford Bldg., Chicago, Ill

Canadian Rep., W. J. Westaway Co.,

Sun Life Bldg., Hamilton, Ont.

400 McGill Bldg., Montreal, Canada.

## H. BRINTON COMPANY

Circular Knitting Machinery

# RIBBERS KNITTERS BODY MACHINES

Each style the latest, with all modern improvements. Simple in construction, well built of the best materials.

*Catalog and samples  
mailed on request*

**213-217 Race St., PHILADELPHIA, PA.**



Parks-Cramer  
Automatic Temperature and  
Humidity Regulator

# This is the Brain of a Scientific Humidifier System

**A** HUMIDIFIER system needs brains. Brains are needed to design, to install and to operate. The more brains that are mixed with a humidifier system—before and after you buy it—the better it will pay you.

This regulator is the brain of a Parks-Cramer system. Only by means of its intelligence are modern installations of humidifiers possible.

Your mill—and its product—is a sponge. But it isn't a Neptune. Soak the water to it. Not too much at a time, but just the right amount all the time.

The brain of your scientific humidifier system is always on the watch.

## Parks-Cramer Company

*Engineers & Contractors*

*Industrial Piping and Air Conditioning*

**Fitchburg**

**Boston**

**Charlotte**

## CLEAN WATER GUARANTEED BY NORWOOD FILTERS

Every bit of dirt, grit and suspended matter is removed from the water by **NORWOOD FILTERS**—they are guaranteed to produce perfectly clean water.

Less time and less cleanser are required to wash with water filtered the **NORWOOD** way, and delicate tints and satisfactory bleaching is assured.

Tell us your needs and we will tell you how a **NORWOOD FILTER** will help you.

**Norwood Engineering Co.**  
FLORENCE, MASS.

*"The House of Taylor"*

## HOTEL MARTINIQUE

BROADWAY, 32d & 33d STS.  
NEW YORK

One Block from Penna. Station.  
Baggage Transferred Free.

Equally Convenient for  
Amusements, Shopping  
or Business.

Direct Entrance to  
B'way Subway  
and Hudson  
Tubes.

600  
ROOMS  
400 BATHS

RATES  
From \$2 Per Day

A SPECIALTY  
155 PLEASANT ROOMS  
With Private Bath

\$3 Per Day

The Martinique Restaurants Are Well Known  
for Good Food and Reasonable Prices.

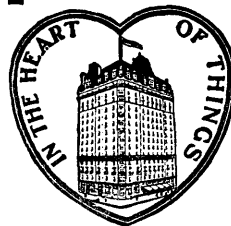

## BIGGER BUSINESS!

There are some 9,000 Textile Mills in the United States and Canada, with 40,000 dealers interested in the Textile Line. Do you realize what an enormous field this is for producing business? Possibly you have a Textile Directory, and make little use of it because it takes so long to find what you want, but have you ever tried **DAVISON'S TEXTILE BLUE BOOK**? Thumb-Index Labels enable you to instantly refer to all sections, and owing to its quickness of reference, the habit grows to refer often. Time is money. **DAVISON'S TEXTILE BLUE BOOK** undoubtedly is referred to three times as often as any other Textile Directory because of these labels, and owing to this, it required nearly one month for us to fill the advance orders on the new edition.

**Davison's Textile BLUE BOOK is 22 directories in one volume.**

*Directories of*

Cotton Mills  
Woolen Mills  
Worsted Mills  
Carpet Mills  
Silk Mills  
Knitting Mills  
Jute and Linen Mills  
Canada Mills  
Dyers, Finishers, Etc.  
Mills with Dye Houses  
Commission Merchants

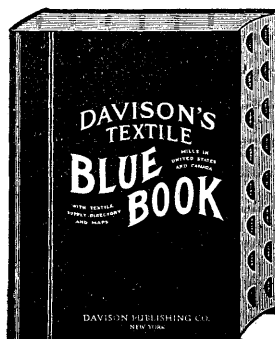

Cotton Goods Converters  
Yarn Dealers  
Raw and Art Silk  
Cotton Dealers  
Wool Dealers  
Rag and Remnant Dealers  
Waste Dealers and Mfrs.  
Linter Dealers  
Mattress Makers  
Textile Supplies  
Classified Directory of Mills

*New Edition 32nd Annual Now Ready*

Office Size \$6.00

Salesman's Directory \$3.00

Handy Size \$4.00

**DAVISON PUBLISHING CO., 50 Union Square, NEW YORK**

# Both Stand for LOWER WEAVING COSTS

*“Scientific  
Lubricants  
for  
Scientific  
Lubrication”*



**T**ODAY, more than ever, the big problem of the textile industry is to cut weaving costs. The best mechanical skill in the country is devoting itself to the task of designing time-saving and labor-saving textile machinery. The great Stafford Automatic Loom pictured above, which is said to save 50% to 60% in weaving costs, is an example of modern textile machinery efficiency.

Hand in hand with the development of textile machinery, the Swan & Finch Company has, by an intensive study of textile requirements, placed the lubrication of textile machinery on a scientific foundation. Through the use of Slo-Flo No. 25, a high grade, non-throwing loom

lubricant, a machine such as the Stafford Loom is made to operate at maximum efficiency. Slo-Flo is the correct lubricant for any type of loom, but it is particularly appropriate for looms built on the basic idea of cutting weaving costs—because Slo-Flo itself is manufactured with the same end and aim.

By eliminating the stained goods loss—by cutting out needless wear and replacements—and by reducing the friction-burden, Slo-Flo effects a very material lowering of weaving costs.

Superintendents of some of the biggest textile mills will testify to the savings made possible through the use of Slo-Flo.

*Write Today for Free Sample*

Chicago  
Philadelphia  
Hartford  
Providence

**SWAN AND FINCH  
COMPANY**  
NEW YORK

Quality  
Lubricants  
Since 1855

# W. D. HUSE & SONS

## LACONIA, N. H.

### The HUSE Improved Winder

Occupies only about half the floor space and runs with half the power required for ordinary winders.

Spindles friction driven—no bands. No vibration. Adapted for winding small sized bobbins by simply changing the cams, or two sizes of bobbins can be run at same time.

Variable speed attachment furnished for skein winding. Extremely simple, durable, smooth-running and has very few parts.

Furnished with any number of spindles desired.

These are but a few of the many points of supremacy.

Write for our catalogue giving full information.

### The HUSE Ribber

This machine is made in any size desired from 2¼ to 6 inches in diameter, and with attachments for making welts, loose courses, tuck stitches and stripes, double knee and high spliced heel.

Can also be used without extra attachments for producing straight ribbed work.

Adapted for making rib tops for half hose, rib legs for ladies', misses' and children's stockings, also for shirt cuffs, drawer bottoms, etc.

Built with either one or two feeds, as best adapted for work required.

Simple, very few parts, and well built throughout.

Send for our new catalogue.

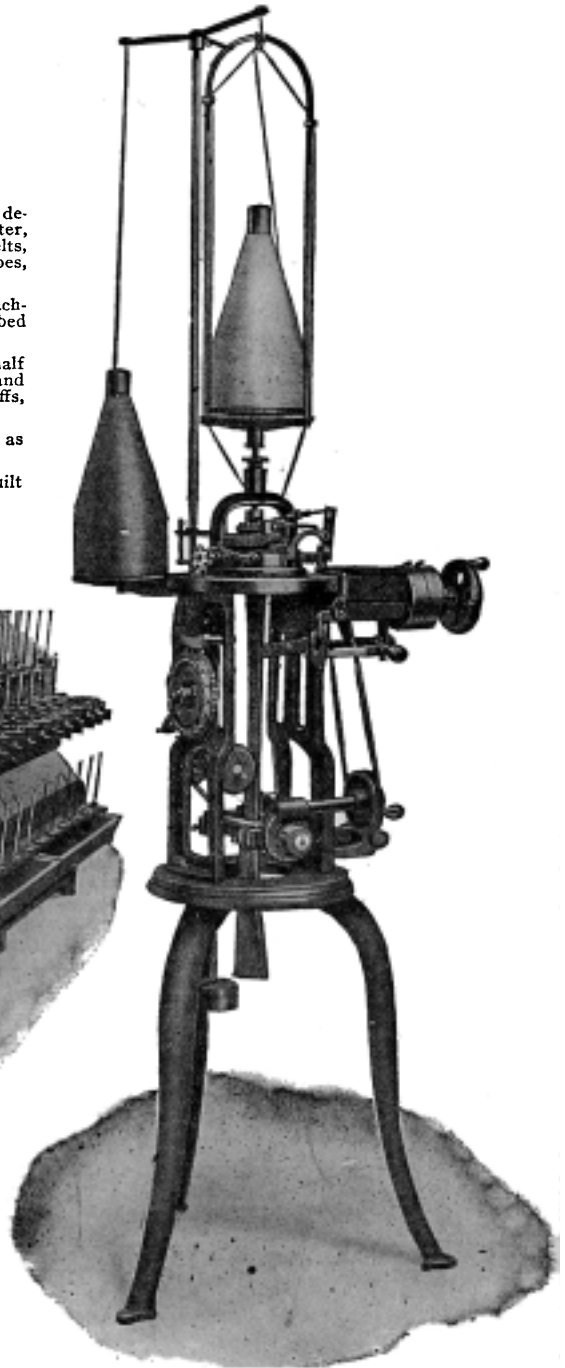
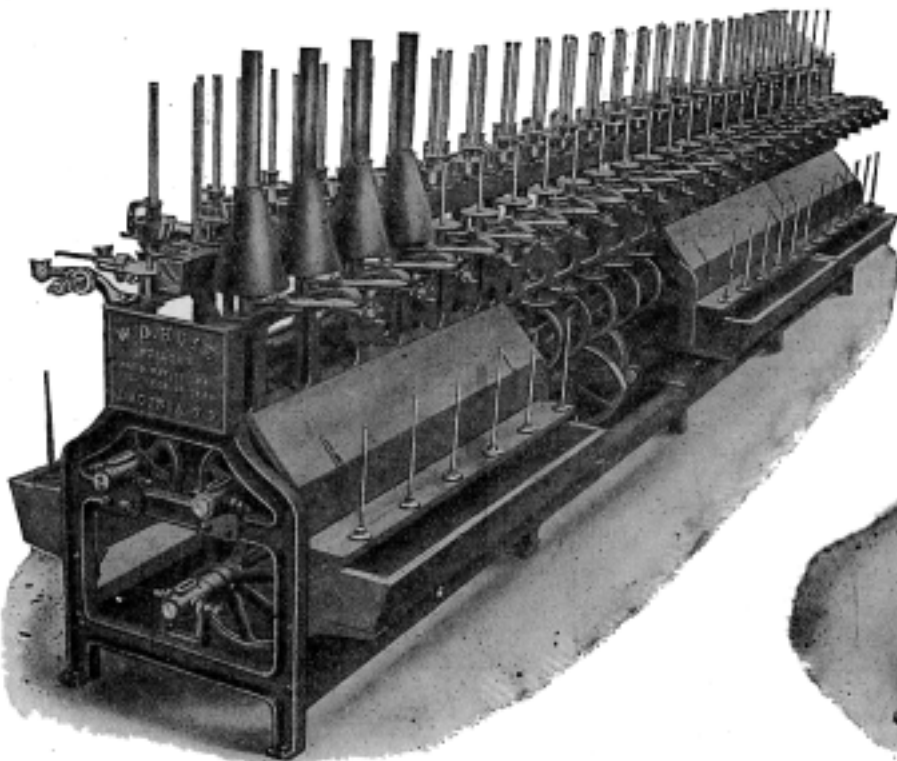

# LACONIA NEEDLE COMPANY, LACONIA N. H.

Manufacturers of  
**HIGH GRADE LATCH NEEDLES**

Thoroughly finished, durable and, we believe, the most satisfactory and economical needles that can be produced. Made by skilled needle makers, from the highest grade wire and on new, improved and accurate machinery.

These needles are carefully inspected before leaving our factory and no effort is spared to keep our output up to the very highest standard. We are confident you would be pleased with these needles. May we send you samples?

# TEXTILES

A MONTHLY TECHNICAL JOURNAL OF THE  
TEXTILE TRADE

Published by

## THE TEXTILES COMPANY

Post Office Square Building : : 79 Milk Street, Boston, Mass.

Telephone Main 19

EDWIN B. PILLSBURY, Business Manager

SAMUEL S. DALE, Editor

Cable Address, "Textiles, Boston"

New York Office: 42 West 39th Street. Telephone Greeley 4295

J. CARLISLE LORD, Manager

### SUBSCRIPTION

In the United States . . . . .	\$1.00	per Year
To Canada and Foreign Countries . . . . .	\$1.50	per Year
Single Copies . . . . .	15	Cents

REMIT TO "TEXTILES" BY EXPRESS OR POSTAL MONEY ORDER, CHECK OR BY ENCLOSING CURRENCY WITH ORDER AT OUR RISK. ADVERTISING RATES SENT ON APPLICATION

Entered as second-class matter January 14, 1916, at the post office at Boston, Massachusetts, under the Act of March 3, 1879, (Copyright, 1919, by Samuel S. Dale.)

# ALLEN BLEACHING KIERS

ALLEN KIERS are either of the Allen Patent Injector Type or "Allen Worcester" Kiers, equipped with Motor driven pump and especially constructed Heater.

The "Allen Worcester" Kier, which is wonderfully popular, is mechanically correct and can be depended upon to do exceptionally good work. The motor driven pump gives positive and even circulation and the strength of the liquor is maintained throughout the Boil. Tendered goods are impossible.

Let us show you these Kiers in operation.

Allen Heating Boilers, Horizontal, Tubular, Upright and Locomotive Type, have been on the market for many years.

We also manufacture the Allen Improved Logwood Extractor.

# WORCESTER STEAM BOILER WORKS

WM. ALLEN SONS CO., Proprietors

GREEN, PLYMOUTH AND WASHINGTON STS. : WORCESTER, MASS.

# "BRETON" MINEROL "F"

For Plush and  
Velvet Finishing

**BORNE, SCRYMSER COMPANY**

80 South Street, New York

BOSTON

PHILADELPHIA

Works: Elizabethport, N. J.

## The Perfect PATENT KNIT-ALL Cone

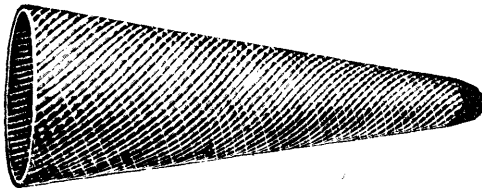

The smooth round polished point allows the yarn  
to knit off without catching and breaking



SEE THE POINT

All Sizes

All Colors

All Kinds of Paper Tubes

Made by

**THE PAIRPOINT CORPORATION.**

Paper Mill and Tube Factory, New Bedford, Mass.

ANDREW G. PIERCE, Jr., Pres.

THOMAS A. TRIPP, Vice-Pres.

FREDERICK R. FISH, Gen. Mgr.

WILLIAM A. CLARK, Treas.

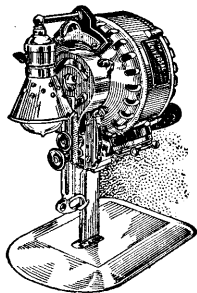

EVERY TIME-SAVING AND CON-  
VENIENT DEVICE IS PROVIDED ON

## UNIVERSAL CUTTERS

ASK FOR A TRIAL. NO OBLIGATIONS

**UNIVERSAL CUTTER CO.**

NEW YORK  
245 Seventh Avenue  
BOSTON

CHICAGO  
506 S. 5th Avenue  
BALTIMORE

PHILADELPHIA  
605 Arch Street  
MINNEAPOLIS

St. Louis, Mo  
CLEVELAND  
1220 W. South Street  
SAN FRANCISCO



# CONTENTS FOR OCTOBER

When a Tariff Does not Protect .....	11
Practical Fixing of Cotton Looms .....	12
Air Moistening in Woolen and Silk Mills .....	13
Cloth Room Report .....	14
Third International Cotton Conference .....	14
Wool by Motor .....	14
Paper Cloth in Spain .....	14
Power Transmission in Textile Mills .....	15
The Identification of Textile Fibers .....	16
French Worsted Drawing .....	17
The Construction of Weaves .....	18
Threatened Confusion in the Textile Industry .....	19
A Profit-Sharing Plan .....	22
Import Licenses in England .....	22
Straight Line Textile Calculations .....	23
<b>QUESTIONS AND ANSWERS</b> .....	24
From Overseer to Superintendent	
<b>KNITTING DEPARTMENT</b> .....	25-26-27
A Warning to Manufacturers—Trademarks in the Hosiery Trade	
—The Manufacture of Knit Goods	
<b>DYEING, BLEACHING AND FINISHING</b> .....	28-29
The Process of Carbonizing—Wet Finishing of Wool Goods—Print-	
ing Vigoureux Worsted—Waste of Steam in Dyehouses	
Recent Textile Patents .....	30
British Dyestuff Situation .....	32

Statement of Ownership and Management of "Textiles," published monthly at Boston, Mass., required by Act of Aug. 24, 1912. Editor, Samuel S. Dale. Business Manager, Edwin B. Pillsbury. Publishers, the Textiles Co., 79 Milk St., Boston, Mass. Owners, Edwin B. Pillsbury, Samuel S. Dale. Bondholders, mortgages and other security holders, none. Subscribed and sworn to by Edwin B. Pillsbury, Sept. 30, 1919, before Frederick J. Kessler, Notary Public.

## "HURRICANE" DYEING, DRYING AND FINISHING MACHINERY, PRESSES, ETC.

### The "HURRICANE" Line of Drying Machinery Includes

- |   |   |
|---|---|
| <p><b>Automatic Loop Dryers</b><br/>For Underwear, Toweling, Piece Goods, Silks, Plushes, etc.</p> <p><b>Automatic Raw Stock Dryers</b><br/>Single and Multiple Apron Types for Wool, Cotton, Linters, Hair, Flax, etc.</p> | <p><b>Automatic Raw Stock Carbonizing Machines.</b></p>   |
| <p><b>Continuous Piece Carbonizing Machines</b></p> <p><b>Automatic Yarn Dryers</b><br/>For Cotton, Worsted, Jute, Silk and Artificial Silk Yarns.</p> <p><b>Truck Dryers for Yarn, Tape, Braid, etc.</b></p>               | <p><b>Automatic Yarn Drying and Conditioning Machines</b><br/>for all kinds of yarn.</p> <p><b>Truck Dryers for Yarn Dyed on Cones.</b></p> |

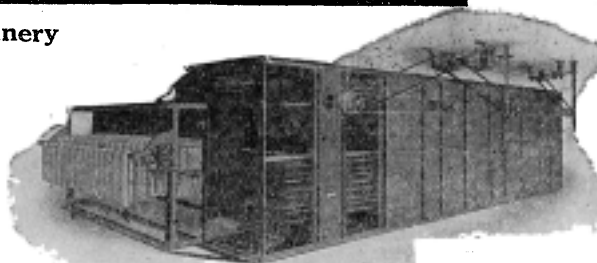

**AUTOMATIC  
YARN  
DRYER**

**THE PHILADELPHIA DRYING MACHINERY CO.**  
MAIN OFFICE AND WORKS: STOKLEY ST. ABOVE WESTMORELAND PHILADELPHIA, PA.

## DU PONT AMERICAN INDUSTRIES



**A** SELF-CONTAINED American dyestuff industry means, first of all, *protection* to America and American industries.

*Protection* to the nation in time of war in that it furnishes the plants, the technique and the intermediate products for the manufacture of high explosives and poisonous gases.

*Protection* to our one source of supply for the synthetic medicinals that are the chief reliance of medical science in relieving pain and in fighting disease.

*Protection* to the textile, leather, paper, printing ink, paint and other dyestuff consuming industries producing over two and a half billion dollars of manufactured goods a year, employing over one million people and representing upwards of two and one-half billion dollars in invested capital.

*Protection* to industries indirectly dependent on an uninterrupted supply of dyestuffs for their maintenance producing over three billion dollars of manufactured goods a year, employing over a million people and representing nearly two billion dollars in invested capital.

In developing and safeguarding, with every means at our disposal, a self-contained American dyestuff industry, American manufacturers are therefore laying and preserving the very keystone of our national and industrial independence.

E. I. du Pont de Nemours & Co.

*Dyestuffs Sales Dept.*

Wilmington                      ∴                      Delaware

Branch Offices

New York                      Boston                      Providence  
    Philadelphia                      Chicago  
    Charlotte, N. C.



# TEXTILES

## WHEN A TARIFF DOES NOT PROTECT.

The Longworth bill has passed the House of Representatives, imposing compound, specific and ad valorem, rates on dyestuffs and prohibiting for two years the importation of dyestuffs except under licenses, which are to be issued for such dyestuffs as may be unobtainable from domestic sources on reasonable terms as to price, quality and delivery.

The bill now goes to the Senate, where it will in all probability be amended, after which, if passed, it will be referred to a conference committee of the two Houses where it will be put into final shape. It is the rule of Congress that in adjusting points in dispute between the House and Senate, the conference committee must adopt some compromise between the two extremes of the House and Senate bills. If, for example, the House bill should limit the license period to two years and the Senate should amend the measure to make the period fifteen years, the conference committee would have to agree on some period between two years and fifteen, say ten.

With the passage of the bill by the House the dyestuff question remains an unsettled issue of vital importance to the entire country, as well as to the textile and other industries. Last month we discussed this question at some length and now we want to emphasize one essential point in connection with the proposed legislation.

### The Tariff Wiped Out.

There have been a considerable number of textile manufacturers and other consumers of dyestuffs, fortunately not so numerous as they were, who have been misled into the belief that the American dyestuff industry can be fully protected against foreign, that is, German, competition by a tariff on imports. For their benefit we will demonstrate why the present abnormal conditions in international trade nullifies the protection that a tariff gives to the American industry in normal times. The reason for this nullification of tariff protection is found in the depreciation of exchange on foreign countries, to which we have repeatedly called attention during the past year. The effect of depreciated exchange on the tariff is particularly severe in the case of dyestuffs because the foreign competition which the American industry would meet comes almost entirely from Germany, the country with which the exchange shows the greatest depreciation.

Take for illustration a thousand pounds of dyestuffs costing M.12 per pound in Germany. Under normal conditions with the German mark at par (24 cents) the price, M.12, would be equal to \$2.88 per pound. With the Longworth compound rate (7 cents per lb. and 45 per cent. ad val.) in force the thousand pounds of dyestuff would stand the American importer as follows, eliminating minor charges, such as freight, for the sake of clearness:

#### (1) Invoice and Tariff Based on Par Value.

1000 lbs. M.12.	M.12,000	=	\$2,880
Duty: 1000 lbs.	.07		\$70.
45% of \$2880	1296.		1,366

Cost in U. S. duty paid	\$4,246
-------------------------	---------

Thus in normal times, and assuming that the German exporter and the American importer unite to render an honest invoice at full value to the U. S. Customs Appraiser, something by the way extremely improbable, this lot of German dyestuffs, costing \$2.88 per pound in Germany, would cost \$4.25 per pound in the United States giving a protection of

48 per cent. Assuming what will be impossible for years, that the new American dye industry has become equal in productive efficiency to the old Germany industry, this 48 per cent. would probably prove insufficient to equalize the difference between American and German wages.

Now let us see how this thousand pounds would work out with the present rate of exchange on Germany (4½ cents per mark) with the American importer paying for the goods at that rate, but with the ad valorem duty still based on the par value (24 cents) of the mark:

#### (2) Invoice Based on Depreciated Value.

##### Tariff Based on Par Value.

1000 lbs. M.12	M.12,000	.045	\$540
Duty: 1000 lbs.	.07		\$70.
45% of \$2880	1296.		1,366

Cost in U. S. duty paid	\$1,906
-------------------------	---------

Thus we find that, as a result of the existing depreciation of German exchange, this lot of dyestuff, after the full duty based on par exchange had been paid, would cost the American importer only \$1.91 a pound, or 97 cents a pound less than the German par value. In other words the depreciation of exchange has wiped out the protective tariff and made the cost of the German dyestuff landed in the United States 34 per cent. less than in Germany. Under these conditions what chance would the struggling American dyestuff industry have in competition with the German trust?

### The Greed of Importers.

But this is not the worst of it. The importers, not only of dyestuffs, but of all other products, are not satisfied with this reduction of the purchase price by reason of the depreciation of foreign exchange. They actually have the hardihood to appeal to the Treasury Department to give them "relief" by basing the ad valorem duties on the depreciated value of foreign money. They have succeeded in getting the New York Custom House to accept payment on the depreciated value and now want the Treasury Department to accept such payment as full liquidation of the duty. The appeal to this effect, addressed to Dr. L. S. Rowe, Assistant Secretary of the Treasury, is signed by the following ten firms of New York customs attorneys representing the importing interests: Brooks & Brooks; Allan R. Brown; Churchill, Marlow & Hines; Comstock & Washburn; Curie, Smith & Maxwell; John Gibson Duffy; Masters & Levett; Sharretts, Coe & Hillis; Strauss & Hedges and Walden & Webster.

Now let us see how our thousand pounds of German dyestuff would work out if the greedy importers have their way and get the "relief" they are clamoring for:

#### (3) Invoice and Tariff Based on Depreciated Value.

1000 lbs. M.12	M12,000		\$540
Duty: 1000 lbs.	.07		\$70.
45% of \$540	243		313

Cost in U. S. duty paid	\$853
-------------------------	-------

So if the importers are allowed to settle, not only the German invoice, but also the protective duty on the basis of depreciated German exchange, this lot of dyestuff, after the duty has been paid, would cost the American importer only 85 cents a pound, or about 30 per cent. of the price (\$2.88) in Germany.

In the face of these facts where is the man who will say

(Continued on following page)

# Practical Fixing of Cotton Looms

By John Reynolds

## The Still Box-Motion.

This device is for the purpose of preventing the boxes from changing when the filling is exhausted or broken, or when the filling fork is not working right. If the brake on a loom is in working order there is little need of a still box-motion because the brake should stop a loom with the shuttle on the box side and the lay of the loom no farther forward than at the bottom center.

No matter what position the shuttle is in when the filling breaks or becomes exhausted, the shuttle must come to the handle side of the loom and the lay must come forward to full front center before the filling stop motion becomes operative and the handle of loom is disengaged. When the lay has passed the front center and is moving towards the back center, the loom should come to a full stop with the lay no farther than bottom center.

If the loom should swing over for another pick and the boxes be changing on this pick, the weaver will find the loom stopped, but a shuttle containing another color with

filling unbroken will be in the box. This often puzzles the inexperienced weaver. It is very easy to discover the cause and apply the remedy. Start up the loom and place the finger on the filling fork so that the handle will knock off. If the loom does not stop on the pick with the shuttle at the box or dobbie side and the loom no farther forward than at the bottom center, it is evident the brake is not working right. If the still box motion is working properly the boxes will not change, no matter how many times the loom swings over after the handle has been knocked off. Fig. 107 shows the still box motion as used on a 2 and 1, 4 and 1, and 6 and 1 gingham loom. The lifting finger A is attached to a rod which extends to the handle side of the loom and is operated by pressure from the filling motion slide. B is the stop plate; C, push arm connected to lever D with a stud. The lever D works freely on the stud E. The lever F also works freely on the stud E. The release yoke G is attached to the

## WHEN A TARIFF DOES NOT PROTECT.

(Continued from previous page)

that a tariff alone will give the necessary protection to the American dyestuff industry? The fact that there are textile and other manufacturers who make this ridiculous claim can be explained on the supposition that they have been misled and have not had an opportunity to study the facts.

### Textiles As Well As Dyestuffs.

Moreover in making that unfounded claim these manufacturers are not only obstructing the development of an American dyestuff industry, which it is their duty as citizens as well as manufacturers to protect, but they are encouraging a policy that may prove disastrous to their own business. This tariff and exchange problem is not merely a dyestuff question. The depreciation of exchange, which we have shown would wipe out a compound tariff on dyestuffs and land the German product in the United States at 30 cents on the dollar affects all imports and would also prove equally destructive to the textile industry of the United States.

If the hosiery, cotton, woolen and worsted manufacturers who are now opposing a license system for dyestuffs want to know how depreciated exchange will affect them when German mills resume operations, let them sharpen their pencils and calculate the effect of a 4½-cent German mark on the ad valorem rates of 30 to 50 per cent. on hosiery, 5 to 25 per cent. on cotton cloth, and 35 per cent. on woolens and worsteds, which the Underwood tariff provides as protection against the products of Chemnitz, Augsburg, Greiz and Gera. They will discover that the depreciation of German exchange would not only wipe out the protection they are supposed to have, but would enable importers to land German textile goods in the United States at a cost far below the value in Germany.

Having brought the depreciated German mark home to their own trades, they would then be the better able to recognize that the only thing that is saving them from destructive competition by Germany is the temporary paralysis of the German textile industry, and that the only way to protect the American dyestuff industry against the annihilating competition of the vigorous and highly organized color trust of Germany is by a combination of a tariff and a license system as provided by the Longworth bill, under which for a term of years German dyestuffs, subject to the tariff, will be admitted by license only when the particular product cannot be supplied on reasonable terms by the American dyestuff industry.

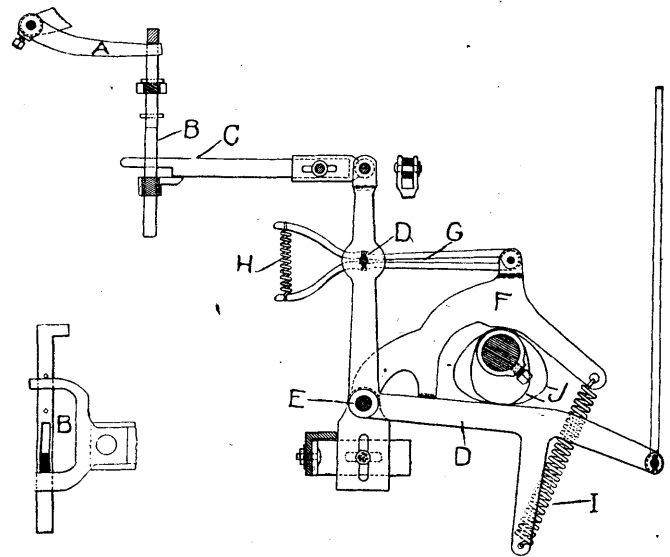

Fig. 108.

Still-Box Motion.

Fig. 107.

lever F and works freely on a stud. The two parts of the yoke extend from this stud and clamp together on a stud located on the lever D, being held together by the spring H. The spring I holds the levers D and F clamped to the double cam J, which imparts motion to the entire mechanism and also to the rod A, Figs. 104 and 105.

Fig. 108 is a front view of the stop plate B showing the slot in which the push arm C slides. When the filling is not broken or exhausted the push arm C is free to pass through the slot in the stop plate B. When the filling is broken or exhausted the filling motion slide is pushed back and acts on the rod, which actuates the lifting finger A, raises the stop plate, and a blank instead of a slot is presented to the point on C. This arm is prevented from moving any farther, and by the continued rise of the lever F pressure is exerted against the stud which holds the yoke G together. The yoke is forced to open up, throwing F out of engagement with the cam J. The jaws open and the cam J revolves between the open jaws without imparting any movement to the rod A, Figs. 104 and 105.

The pattern chain cylinder does not move and the boxes cannot change. This condition continues as long as an empty shuttle or a shuttle with broken filling is running in the loom. When the filling is replenished the stop plate B is allowed to fall and the jaws D and F automatically close again.

# Air Moistening in Woolen and Silk Mills

By Robert Dantzer

All textile fibers present a large area to the air and are hygroscopic, that is to say, they possess the property of absorbing moisture from the surrounding air until they reach a state of equilibrium. It is easy to understand that this equilibrium is a function of two variables: (a) relative humidity; (b) temperature of the air. It follows that the estimate of the weight of a mass of fibers is susceptible to error, the weight varying under the influence of atmospheric conditions. In commercial transactions the process known as conditioning is used to correct in a certain degree the influence of humidity on the weight of textile materials. According to M. Chevreul, wool is more hygroscopic than is other textile materials. He found that 100 parts by weight of bone dry wool when exposed to a saturated atmosphere at 65° F. weighed as follows at the end of several days:

Merino wool in the grease	182.40
Merino wool desuinted	139.71
Merino wool scoured	138.14
Merino wool in spun yarn	134.57
Merino wool in unfinished cloth	132.75

At the Bureau Militaire de Conditionnement at Vienne, M. Girard experimenting with wool at a temperature of 70° in saturated atmosphere, reach the following results, which vary slightly from those given by Chevreul:

Patagonia wool in the grease	180.7
Cape wool scoured	136.8
Wool cloth sky blue	138.5

The influence of humidity is greater on raw wool, that is to say, when loaded with grease and saline matter soluble in water.

According to Otto Willkomm heat and humidity causes a swelling of the fibers which increase in volume and length. He also found that animal filaments, silk and wool, stretch more than those of vegetable origin. While the humidification of cotton results in greater cohesion of the short fibers and it seems probable that the humidity in wool disintegrates the scales of the fiber, which explains the decrease in strength, while the elasticity is increased. Heat and moisture facilitate the straightening of the fibers by increasing the flexibility and elasticity, making it easier for the fibers to slip on each other; the reduction in the strength of the fibers being largely offset by the advantages realized.

Under the influence of a relative humidity of 70 to 80 per cent. wool fibers are more lustrous, nearer round and more elastic. If, however, the humidity is increased all these qualities disappear. From this we can conclude that there is a degree of relative humidity that is favorable to the working of each kind of textile material. This question as affecting cotton has been studied by Willkomm, Baker, Muller and others.

In working animal fibers the relative humidity of the air facilitates the dispersion of static electricity which may be generated and of which the intensity increases with the dryness of the air. As is well known, the filaments charged with the same kind of electricity tend to repeal each other and to separate, causing rough and twitty yarn. The air being a better conductor when charged with humidity tends to prevent the accumulations of electricity and protects the fibers by re-establishing electrical equilibrium. Otto Willkomm has determined at what relative humidity the air becomes a good conductor for neutralizing the disturbance of electrical equilibrium. In making his experiments he used an electroscope from which he found that the discharge de-

creased progressively but slowly up to a relative humidity of 68 per cent. Above 68 per cent. the period of the discharge decreased very rapidly, and above 70 per cent. the discharge of electricity no longer had an injurious effect on the work. From this it was concluded that for the purpose of preventing static electricity the relative humidity should be 70 per cent. in the work rooms. Spennrath described a method for determining whether the relative humidity of a working room was sufficient for neutralizing electricity. A piece of paper having been coated with resinous paste is dried and then subjected to friction in the room to be tested. The friction electrified the paper which is then placed against a wall. If it sticks to the wall the air is too dry. If, on the contrary, it falls to the floor, the relative humidity is sufficient.

Furthermore, the researches by MM. Szilard & Strohl have revealed methods by which static electricity in fibers can be neutralized without humidification.

## Humidity in Working Worsted.

*Carding.* Humidification is required as soon as the carding process begins. The double cards in general use are equipped with a burring apparatus at the feed end. In order to facilitate the removal of the burrs, the wool should be dry, but for the carding process which follows immediately the wool should be moist in order to prevent the material from winding around the doffer. As these ideal conditions are impossible of attainment the practice is to have the wool carry a slight amount of moisture. The card rooms should be kept at a temperature of about 72° and a relative humidity of 75 to 80 per cent.

*Combing.* The temperature of combing rooms should be kept at 72° to 77° for the expansion of the machine parts may cause bad work. A relative humidity of 75 to 80 per cent. gives the best results.

*Drawing and Spinning.* In the drawing room the temperature should not fall below 72° with a relative humidity of 75 per cent. When the yarn is spun on frames the temperature should be from 72° to 75° and the relative humidity 75 to 80 per cent. As these spinning machines generate more heat than the self-acting mules it is necessary to supply more moisture to the room. In mule spinning rooms the temperature should be at least 75° and the relative humidity from 80 to 90 per cent., the latter varying in proportion to the fineness of the yarn spun.

## Humidity in Woolen, Carding and Spinning.

As the result of the oil applied to the wool the fibers become very flexible providing the oiling solution is sufficiently fluid. The required fluidity is obtained at a temperature of 72° in card rooms and 75° in spinning rooms. The relative humidity should be at least 60 per cent. in the card room and 70 per cent. in the spinning room.

## Humidity in Silk Mills.

Silk is dielectric which makes it a good insulating material for electricity. Its high degree of porosity enables it easily to absorb vapors and gases. In the raw silk preparatory operations the relative humidity of the work rooms should be 70 per cent. and the temperature 64°, the heat softening the silk gum. The rooms in silk throwing mills should be kept at a temperature of 72° with a relative humidity of 85 per cent. These atmospheric conditions are

adapted for doubling organzine, grenadine and silk twine, while for doubling tram and twisted silk a relative humidity of 65 per cent. is sufficient.

Special care is necessary in handling silk, owing to the ease with which the silk fibers are electrified. Simply rubbing the silk fibers against each other generates positive electricity when the rubbing motion is lengthways of the fiber, while negative electricity is generated when the motion is crossways. Owing to the dielectric property of silk this textile material is neutralized with great electricity, the fibers repelling each other and the material forming into a quantity of kinks and snarls which cause imperfections and waste. To reduce this difficulty it is the practice to leave about 5 per cent. of silk gum on the fiber. The silk gum becomes electrified more slowly than the silk, but the silk yarn thus produced is not so brilliant and loses weight during the dyeing process.

#### Humidity for Schappe Manufacturing.

The working of silk waste likewise calls for a definite degree of relative humidity and of temperature. In the combing rooms the temperature should be 72° with a relative humidity of 70 per cent., while for carding a relative humidity of 65 per cent. is sufficient. In the spinning room the temperature is usually 72° with a relative humidity of 65 per cent. for filling yarn and 70 per cent. for warp yarn.

#### Humidity in Weaving.

Humidification of the air is frequently dispensed with in woolen and silk weave rooms because, as we have seen, it causes a decrease in the strength of the yarn. Nevertheless, the constant friction to which the yarn is subjected develops static electricity which interferes with the work. For this reason a constant temperature of 64° and a relative humidity from 70 to 75 per cent. are recommended for wool and silk weave rooms.

#### Removing Electricity from Textile Fibers.

From what has been said it is clear that the humidification of work rooms is intended to facilitate the passage of the electricity which is generated during the process of the manufacture. Attempts have been made to remove static electricity from textile fibers by means of an electric current passed across the machines by insulated conductors, the current being generated either by a coil or an electric generator. The danger of receiving a shock by getting in contact with the conductors, and the difficulty of assuring an exact neutralization without producing a reverse current have caused these methods to be abandoned.

After being subjected to a mill test the electrical method of neutralizing fibers high frequency and high tension currents, as proposed by MM. Paillet, Ducretet and Roger, received the commendation of the Academy of Sciences. Another method proposed by MM. Szilard and Strohl was also commended by the Academy. It consisted in applying a special solution which did not affect the properties of the fiber. In certain cases the press rolls of the preparatory machines were subjected to a special treatment which was varied to suit leather and parchment rolls for the spinning of wool, and rubber rolls for the spinning of waste silk. Good results were obtained with these processes under conditions that would otherwise have been considered very bad for working the material.

Neutralization of textile materials and textile machines improves the working conditions by preventing all tendency of the fibers to stick together, reducing the amount of waste made and making it possible to increase the speed of the machine.

### CLOTH ROOM REPORT.

The form shown this month is used for reporting daily the cloth delivered to the cloth room from weave room, also the goods inspected and baled. It is suited for the requirements of a small mill and gives the manager a statement every morning as to the work done in the cloth department

#### CLOTH ROOM DAILY REPORT

March 5 19

Rate		Amount		CLOTH RECEIVED FROM WEAVE ROOM						
No.	Name	Rate	Amount	Code	Parcels	Style	Construction	Width	Received Wt.	Ac. Wt. Unbaled
1	FOREMAN	55								
1	STITCHER BOY	20								
2	INSPECTORS	35	276	3461	C	48x48	40	4.	4.02	
1	PRESS MAN	30								
1	Folder	30								
TOTALS										

RECORD OF CLOTH INSPECTED AND BALED									
No. Bales	Style	Construction	Width	Received Wt.	Ac. Wt. Unbaled	Yards Baled	Parcels Baled	Grade	Per Cent. Baled
12	C	48x48	40	4.	4.02			C	
35 LBS. RAGS									
15 LBS. SWEEPS									
10 HOURS RUN									

the previous day. The hours run and the amount of rags and sweepings are also reported on the same blank.

### THIRD INTERNATIONAL COTTON CONFERENCE.

Nearly one hundred English and Continental cotton spinners and manufacturers arrived in New York on Sept. 23 en route to the Third International Cotton Conference, which opens in New Orleans on Oct. 13. The European delegation was headed by Sir Herbert Dixon, chairman of the Fine Cotton Spinners' and Doublers' Association, which operates about 7,000,000 spindles. The secretary of the delegation is Frank Nasmith, editor of the Textile Recorder, and in the party is Arno S. Pearse, secretary of the International Cotton Federation. There are in the delegation representatives of the cotton trade of England, France, Belgium, Switzerland. After visiting Boston and a number of mills and machine shops in New England the visitors will proceed to New Orleans where an elaborate program has been arranged for the Conference.

### WOOL BY MOTOR.

The suggestion that motor vehicles should be employed to facilitate the delivery of wool from London to Bradford (180 miles as the crow flies) has at length borne fruit. It occurred to the Ministry of Munitions that as certain motor wagons were going to Yorkshire, about 60 in all, it would be folly to allow them to travel empty, which was quite a good idea, and accordingly they were laden with bales, and some 160 tons of wool were thereby conveyed from London docks to Bradford warehouses.

### PAPER CLOTH IN SPAIN.

The British Vice-Consul at Granada, Spain, states that a local firm has erected a factory in which it is intended to manufacture thread from paper and to weave cloth from it for the packing of their products. The necessary raw material is obtained from eucalyptus wood, of which tree the company has a large plantation. The process of its manufacture is described as follows:—From wood paste paper is made which is cut in long narrow ribbon-like strips. These are wound on reels and are placed in a spinning frame the spindles of which make 5,000 to 6,000 revolutions per minute. In this process the twisted paper forms a tube of little strength. It is now soaked in a special glue which becomes insoluble when exposed to hot air, and considerably increases the strength of the yarn. The thread is then stretched to obtain the necessary firmness, but is too coarse to be woven into a substitute for either linen or cotton cloth.—Textile Mercury.

# Power Transmission in Textile Mills

By Charles L. Hubbard

## Angle Couplings.

These couplings, sometimes called "universal joints," are used where it is necessary to change the direction of a shaft a limited amount without the use of bevel gears or special arrangements of belting. The joint or coupling shown in Fig. 34 has a working range up to 25° between the axes of the two shafts, while a double joint of the same type will operate up to an angle of 70°.

The speed of a universal coupling should not exceed 200 r. p. m., and in any case the angle and speed of shaft should

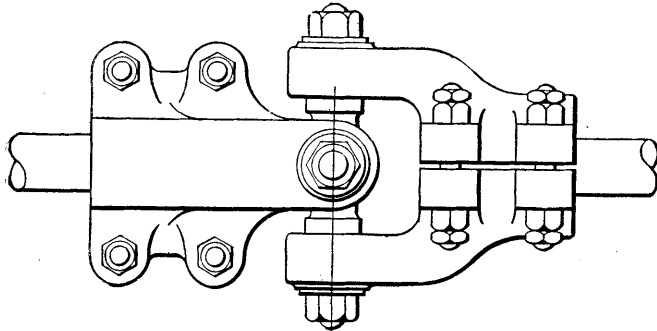

Fig. 34. Angle Shaft Coupling.

be considered together when planning for a device of this kind. Standard forms of these couplings are made to operate on shafts up to 5 inches in diameter.

## Collars.

To prevent a line shaft from having too much play lengthways, it is common practice to place a collar at each end near a bearing. In many cases the same result is obtained by placing a pulley near a bearing and letting the hub act as a collar. This arrangement is open to the objection that oil is apt to work out from the bearing and be thrown by



Fig. 35.

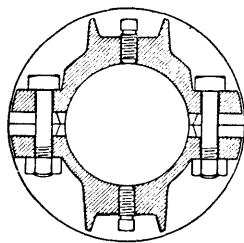

Collars.

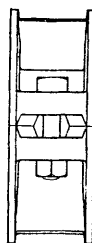

Fig. 36.

the rapidly revolving shaft upon the belt passing over the adjacent pulley, a condition which should always be avoided when possible. The collars used for this purpose are of two general forms shown in Figs. 35 and 36. The first, Fig. 35, is solid and must be slipped on over the end of the shaft. The second is made in halves and can be put on and taken off without disturbing the shaft. As in the case of couplings, there should be no projections, such as bolt heads or set screws for catching the clothing of operatives.

## Bearings.

Under this heading is included a great variety of appliances of especial importance in the transmission of power. It has previously been stated that under average conditions from 30 to 40 per cent. of the power delivered to the line shafting is lost in friction before it reaches the points at which it is to be used, and that in many cases these figures are greatly exceeded. As this waste of energy takes place

almost entirely at the bearings it is important that this detail of power transmission should receive careful consideration.

A shaft bearing consists of two essential parts, the *box*, so called, and the *support*. The box ordinarily consists of a cast iron shell lined with a softer metal and provided with a special means for lubrication.

The bearing is divided longitudinally into an upper and a lower half so it may be placed on the shaft after the latter has been supported in position.

A typical bearing of the ring-oiling type is shown in Fig. 37 and illustrates the general construction of this device. The bearing proper with its special lining is indicated by the letter H. The outer shell projects beyond the inner bearing in order to prevent oil from being carried outside and thrown from the shaft by centrifugal force. An oil reservoir is pro-

Fig. 39. Bearing With Wicks.

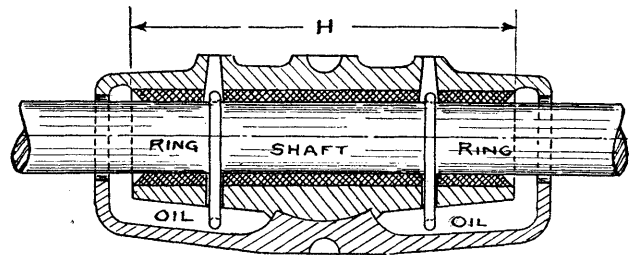
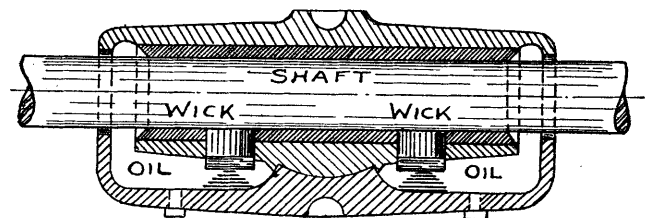

Fig. 37. Ring-Oiling Bearing.

vided at the bottom of the casing as shown. Continuous lubrication is accomplished by steel rings of a larger diameter than the shaft, which dip into the oil at the bottom and carry it up over the top as they slowly revolve. Either one or two rings are provided, according to the length of the bearing, and in some makes chains are substituted for the rings.

When placed at the end of a line or on a counter-shaft, one end of the outer casing is usually closed, and sometimes enlarged sufficiently to include a collar. With bearings of this type oil should be added about once in three months and the reservoir should be cleaned and refilled with fresh oil about once a year.

In the bearing shown in Fig. 38, a split collar is clamped to the shaft at the center. Oil stored in a reservoir at the bottom is continuously elevated to a distributing reservoir at the top by the act on of the collar, from which it flows by gravity over the entire surface of the journal, as shown. In addition to replacing the rings previously described, the collar takes the end thrust of the shaft in either direction, thus doing away with outside collars except under especially severe conditions. Furthermore, the collar runs in oil against babbited seats instead of unlubricated iron surfaces as is the case with an outside collar, where no oil is present unless it works out of the bearing.

When oil leakage does take place, as noted above, it is liable to be thrown off from the rapidly revolving collar, a

(Continued on following page)



# The Identification of Textile Fibers

By Dr. Louis J. Matos

One of the most important chemical points to be observed by those following micro-chemical work with fibers, is to make a positive distinction between cotton and flax. Many directions for distinguishing cotton and flax have been published, but one of the most important is to employ olive oil or two dyestuffs, methylene blue or safranin. If threads of cotton and flax are immersed at the same time in a weak solution of methylene blue for a few minutes, it will be found after washing, that the flax has taken up a much greater depth of color than the cotton. On the other hand, if some threads are placed in a solution of ammoniacal fuchsine, the flax fibers will be found more heavily stained than the cotton.

The olive oil test for cotton and flax is based upon certain physical characteristics that have to do with the transmission of light through cotton and linen mixed cloth, or with the reflection of light from such cloth.

If a piece of clean cloth, containing both cotton and flax is slightly saturated with olive oil, the excess of oil removed, the cloth covered with a cover-glass, and examined under a low-power microscope and with transmitted light, that is, light projected through the instrument from the mirror, the cotton fibers will appear very non-transparent and dark, while the flax fibers will appear almost clear. On the other hand, if the light is reflected down upon the specimen on the glass, the cotton will appear quite white and brilliant, while the flax will appear dark.

Another test for cotton and flax is to soak a clipping of the fabric in a few drops of 66° sulphuric acid for one to two minutes, and then wash well in water and dry. By this treatment the cotton becomes disintegrated, while the flax fibers remain almost intact.

Observe first with low power and afterwards with the higher power, noting all the characteristics of the outline of

## POWER TRANSMISSION IN TEXTILE MILLS.

(Continued from previous page)

condition to be avoided in textile mills so far as possible. With the enclosed collar, this is avoided, thus making it especially adapted to this class of work. When used on line-shafts it is best located at or near the main driving pulley.

In the bearing shown in Fig. 39 the oil is supplied to the journal through wicks by capillary attraction. With this arrangement oil should be supplied about once a month, nearly to the bottom of the journal, and the reservoir cleaned and

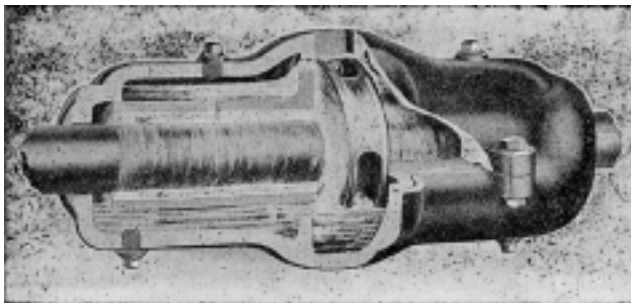

Fig. 38. Split Collar Bearing.

refilled every three to six months, according to speed and surrounding conditions. The wicks used for this purpose are constructed of various material including felt, wood and metal and must be sufficiently porous to produce the necessarily capillary attraction. Certain forms are provided with means for moving them up against the shaft automatically as the upper end becomes worn or the shaft is pulled away slightly from the bottom of the bearing.

the section and particularly of the canal or "lumen" in the center of the fiber section. Observe particularly whether this canal contains or is free from deposits of granules. Observe also any distinctive coloration, and if possible make comparisons with authentic drawings of the cross section of the fibers of known origin and identity.

The cross section of the flax fiber is, roughly, hexagonal in shape, but not strictly so. The center canal is very small and the cell wall is very thick. The canal is quite centrally located and is more or less circular. The fiber viewed longitudinally shows the canal somewhat yellowish and when very much enlarged appears to contain granules that do not completely fill. The surface of the fiber has certain distinctive, cross-like markings which are bluish, Fig. 16.

Hemp fiber is scored crosswise with fine markings, but also carries more or less distinct markings longitudinally. Hemp is characterized by certain small "spicules" that branch off

Fig. 16. Fig. 17. Fig. 18. Fig. 19. Fig. 20.

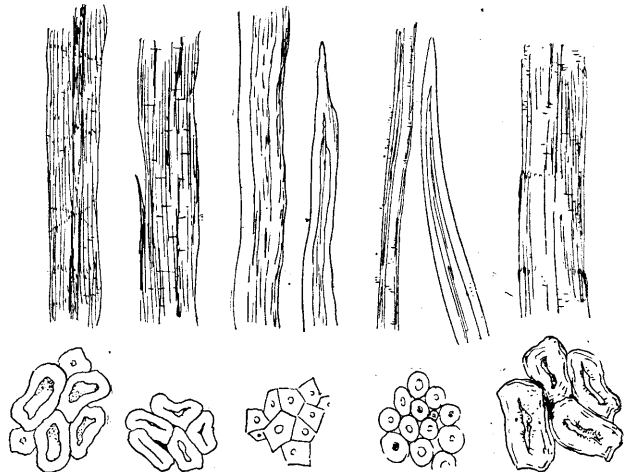

Characteristic Points of Bast Fibers.

from the outside of the fibers. The fiber tips are more or less blunt. In cross section, after treatment with Vetillard's reagent, the fiber wall is bluish, but the central portion,—that portion next to the canal—has a very much deeper coloration, Fig. 17.

Jute, on the contrary, has a large canal and when viewed in cross section, the shape is very angular. Lengthwise the canal appears very distinct. The tips of the fibers are somewhat blunt, but not nearly as blunt as hemp. The color reaction with the iodine solution is yellow, Fig. 18.

New Zealand hemp, occasionally met with in the manufacture of cordage, is a fiber that is small in diameter. In cross section it is devoid of any angular shape. The cell wall is moderately thick. Many of the fibers appear to contain granules in the central canal. The fibers do not appear to have been compressed together as the other previously mentioned fibers have been. There are transferred scorings on the fiber. The tips are somewhat pointed and resemble the flax fiber in this particular. The color reaction with Vetillard's reagent is yellow, while the granules in the canal, when present, are brownish, Fig. 19.

Ramie or China Grass differs very materially from the other fibers when viewed in cross section. The fiber appears to be somewhat compressed together and shows distinct layer markings. The center canal is not smooth, but rather rough, and contains granules. The tips of the fibers are blunt. The coloration, due to the action of Vetillard's reagent is bluish, inclining somewhat to a gray. The canal contents, when present, are brownish. Ramie is distinguished by its large cross section, Fig. 20.



# French Worsted Drawing

By Leon Faux

## Circular or Soleil Gills.

This gill-box shown at Fig. 115, combines two fundamental types, that of the straight comb by the elements of the comb P, which are the bars; and that of the circular or porcupine comb by the circular movement of the bars. The machine has 68 bars .32 inch wide, each carrying two rows of pins having working heights of .64 to 1 inch and set 10 to 11 pins per inch for merino wool.

The bars rest on eccentric guides E x, fixed on the shaft A x. They are given a continuous circular movement by the discs S, called *soleils*, in which are cut the grooves s to engage the shoulders at the extremities of the bars.

The passageways G, formed by the slope of the eccentric E x and the supports R, guide and support the bars in all of their positions. From  $a^1$  to  $a^2$  the pins penetrate the layer of fibers as in the case of the ordinary porcupine roller. From  $a^2$  to  $a^3$  the bars gradually assume an upright position

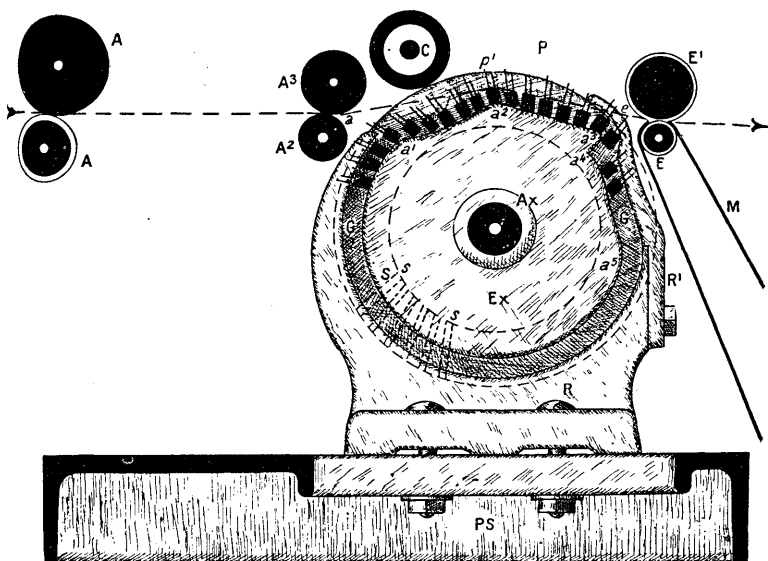

Fig. 115. Circular Gill-Box.

at right angles to the movement of the wool, and then assume a position inclined toward the drawing point. Between  $a^3$  and  $a^1$  each bar is withdrawn successively from the fibers while guiding them as near as possible to the drawing point, after which they are carried to the positions  $a^1$  through the passageway G.

## Anti-Flexion Drawing Rolls.

It will be noticed for example in Figs. 106, 107 and 109 that the diameter of the upper or press-roller  $E^1$  is approximately the same as that of the lower drawing roll E. In the intersecting gill-box it is necessary to incline the line connecting the centers E  $E^1$  if the upper roller  $E^1$  is larger than the lower roll, this position reducing the pressure on the wool; it otherwise is necessary to make the upper roll  $E^1$  smaller in order to bring the center line vertical and obtain the full amount of the pressure. An upper roll of small diameter, however, is incompatible with the high pressure that is required. The pressure which is applied by the hooks C, Fig. 116, on the free ends of the roll cause a flexion of the roll which results necessarily in an irregular drawing action across the width of the apron.

Offerman has invented a device patented by Skene and Devallee to prevent the flexion on a small upper roll. To ac-

complish this the small rollers  $R^1$ , Fig. 116, are fastened on the roller shaft  $E^1$  between the end of the shaft and the pressure hook C. Each of these small rollers  $R^1$  rolls on another small roller R, fixed on the shaft E of the lower drawing roll. As the diameters of the small rollers  $R^1$  R are determined by the distance between the centers of the upper

Fig. 116.

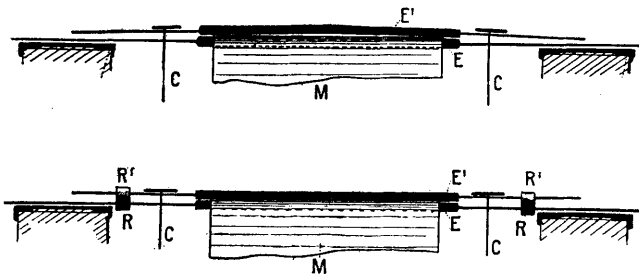

Fig. 117. Anti-Flexion Drawing Rolls.

and lower drawing rolls E  $E^1$  when under pressure, there is a contact between the small rollers R  $R^1$  with enough pressure of the apron to give the required draft of the wool.

This arrangement prevents the flexion of  $E^1$ , which can be nearly as small as E, the pressure of each hook C being exerted between two resistances approximately equal.

The flexion of small drawing rolls in gill-boxes is also counteracted by making the roll slightly convex, this convexity amounts to about 1/32 inch on a 1-inch roll, with the result that the flexion of the roll causes the convex line to straighten during the drawing process.

## Different Types of Gill-Boxes.

Gill-boxes are usually built with three or four heads, and sometimes with as many as six. They can be divided into three classes:

1. The machines in which the different heads have but one drive, each head delivering the sliver to a spool. This type is used for gilling combed top, also for the first passage in the mixing group in preparation for spinning.

2. The gill-boxes with four heads with a separate drive for each pair of heads. This type is used for gilling combed top.

3. Mixing gill-boxes. Each head has an independent drive. In this type of machine the drawing rolls are necessarily driven at the same speed. The independent drive enables each head to operate with a different draft, making it possible to produce a uniform mixture from feeds of combed sliver varying widely in weight. All the different layers of wool, combined and super-imposed on each other, are fed to an auxiliary head placed crossways at the side of the machine and which unites all of the layers into one sliver. This auxiliary head, which may or may not draw the wool, delivers to a spool or a can the material with the width reduced and which has been formed by combining all of the slivers delivered by the different heads. This method gives much more uniform mixtures because they are formed by superimposing all of the slivers drawn by the heads of the machine and thus forming only one sliver. On the ordinary gill-box which delivers the sliver directly from each head to a spool or can, the mixture is made by simply placing side by side the different slivers that are doubled into each head.

# The Construction of Weaves

By E. Bittner

Fig. 536. 4-leaf filling twill; warp, 3 dark 1 light; filling, 1 light 1 dark.

Fig. 537. 4-leaf filling twill; warp and filling, 8 threads.

Fig. 538. 4-leaf warp twill; warp and filling, 1 light, 1 dark.

Fig. 539. 6-leaf balanced twill; warp, 6 threads; filling, 3 threads.

Fig. 540. 4-leaf broken warp twill; warp and filling; 1 dark 1 light.

Fig. 547. 4-leaf zig balanced zig-zag twill 8x4; warp and filling, 4 dark 4 light.

Fig. 548. 6-leaf balanced twill; warp and filling, 2 dark 2 light.

Fig. 536.

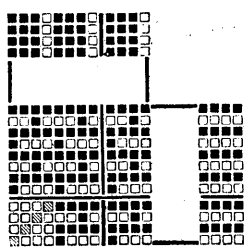

Fig. 537.

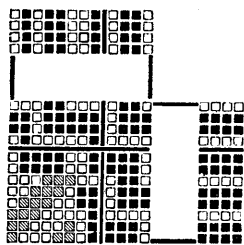
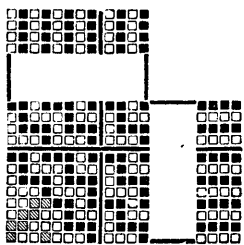
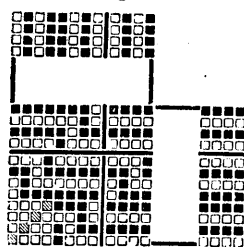

Fig. 538.

Fig. 539.

Fig. 541. 4-leaf broken warp twill; warp, 4 threads; filling, 2 threads.

Fig. 542. 4-leaf zig-zag warp twill 6x4; warp, 6 threads, filling, 4 threads.

Fig. 540.

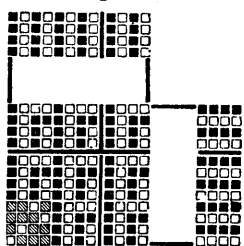

Fig. 541.

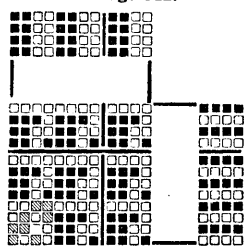

Fig. 544.

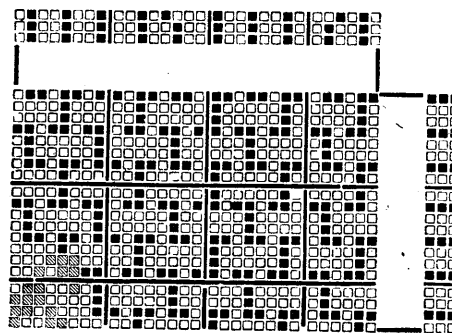

Fig. 545.

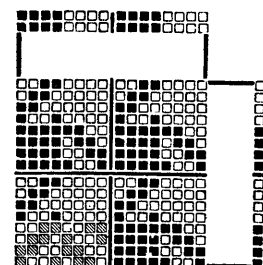
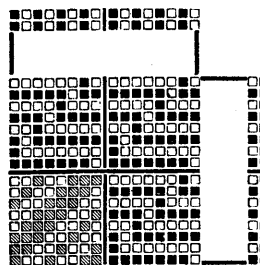

Fig. 546.

Fig. 547.

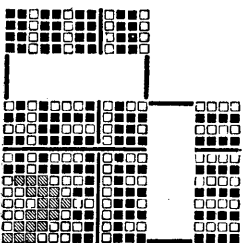
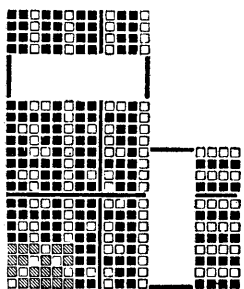

Fig. 542.

Fig. 543.

Fig. 543. 6-leaf balanced zig-zag twill 6x6; warp, 3 threads; filling, 2 threads.

Fig. 544. Modified warp twill 8x8; warp and filling, 1 light 1 dark.

Fig. 545. 6-leaf balanced broken twill 6x6; warp, warp and filling, 1 dark 2 light.

Fig. 546. Modified warp twill 8x8; warp and filling, 1 dark 1 light.

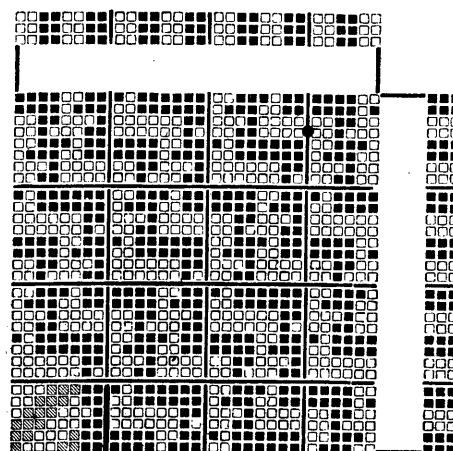

Fig. 548.

# Threatened Confusion in the Textile Industry

[Measured by the number of wage earners, capital employed or wages paid, textile manufacturing is the leading industry of the United States. One of the most valuable possessions of this great industry is the system of textile standards based on a few convenient English units of weight and measure. It is a remarkable fact that practically all of the measurements that are necessary in the many complicated processes of manufacturing textiles are made with six units, two of length and three of weight, the yard, inch, pound, ounce, dram and grain. This simplicity of standards which are as familiar as our mother tongue, greatly facilitates calculation and understanding at every step in the manufacture and marketing of textile products. And yet, despite the great advantages of this precious inheritance, there has been carried on for years a persistent propaganda by a powerful group to introduce by force into the United States a foreign system of weights and measures.]

Strange to say, this movement to destroy the uniformity of our standards of measurement has had its headquarters in the Bureau of Standards at Washington, which was established in 1901 for the custody, comparison and testing of standards, but which for nearly twenty years its officials have made an agency for the destruction of our established standards of measurement. If the textile manufacturers of the country had realized what a calamity the success of this bureaucratic campaign would bring to their industry, Congress and the Departments at Washington would have been deluged with protests against the propaganda from every branch of the textile trade. Instead of this, however, the textile trade has remained indifferent while the propaganda went on. Why? Simply because we do not appreciate pure air until we pass from the atmosphere outdoors to a crowded room in which the air has been polluted by the breathing of the occupants, nor a common language until we have occasion to communicate with those whose language is strange to us and who do not understand our mother tongue.

So with weights and measures, we do not realize the inestimable value of simplicity and uniformity until we are involved in the confusion of multiple standards, as are the textile manufacturers of the Continent of Europe, who are compelled to struggle, both in the mill and the market place, with an incurable and indescribable mixture of the metric units, which have been forced on them by law, and the pre-Revolutionary and English units, which they cannot and will not abandon.

Realizing these truths about weights and measures the writer has for years done what he could to defend our established standards of measurements against all assaults. Recently a new phase of the propaganda to involve our weights and measures in confusion has developed, and to which attention is called in the following statement.]

For the past six months, beginning with March, 1919, a mysterious propaganda has been carried on by mail throughout the United States and Great Britain under the name of "The World Trade Club," with headquarters at San Francisco, from which city vast quantities of expensive literature have been mailed broadcast, appealing to all classes of people in all parts of the United States, Canada and Great Britain for support of a movement to secure legislation by the United States Congress and the British Parliament making the use of metric weights and measures compulsory and prohibiting the use of the English weights and measures now established.

## A Mysterious Organization.

The mystery surrounding this World Trade Club of San Francisco was due to its sudden appearance, no one ever having heard of it before, the vast extent of its mail campaign, whether measured by the number of expensive circulars sent out or the great extent of territory covered, the lavish expenditure of money in the work, and the deliberate omission of the name of its principal, if not its only, financial backer from the literature distributed by the Club.

The arguments advanced in this San Francisco literature

deserved no consideration in any serious discussion of weights and measures, but were framed to appeal to the large number who habitually confuse the metric system with decimals, and currency with weights and measures, and to stir up a senseless clamor instead of leading men's minds to the truth. So instead of attempting the impossible task of drowning it with a counter clamor I have directed my energies to finding out what was back of this mysterious propaganda. During the six months that it has been under way I have been patiently collecting the evidence and now the occasion seems opportune to make public what I have discovered.

In reporting my findings I shall not refer by name to one important individual connected with the World Trade Club, but shall designate him as "Mr. Z.," leaving it to Mr. Z., if so disposed, to make known his identity and give to the public the information that I have not yet secured. Various sources of my information will be designated by numbers as I have not asked permission to make public the names of my informants.

## Chronology of the Propaganda.

**March 29.** The World Trade Club's mail campaign begins with an expensive circular printed in colors, accompanied by a circular letter bearing the printed signature "Wm. E. Hague, Secretary-Treasurer," asking that the recipients sign the petitions enclosed and addressed to President Wilson, the House Committee on Coinage Weights and Measures, British Prime Minister Lloyd-George and the British Parliament, endorsing the exclusive use of the metric system "by legislation, promulgation or order in council" in the United States and British Isles, two stamped envelopes addressed to the President and Prime Minister being also enclosed for mailing the petitions.

Attached to the circular was a slip on which was printed this request:

This is a copy sent to you in advance of printing a very large edition. Can you improve, strengthen, condense, correct or contribute one more fact? Do it for the benefit of all human kind. Do it quickly, for the press is started. *Telegraph Collect*, Ramsey Mailing Co., 618 Mission St., San Francisco, World Trade Club."

**March to September.** Four different editions of the World Trade Club circular, revised and printed in more expensive form, are spread broadcast throughout the United States, Canada and Great Britain, being mailed, not only to newspapers and organizations, but to individuals in all walks of life, and in every case enclosed with pro-metric petitions and stamped envelopes addressed to President Wilson and Prime Minister Lloyd-George.

**July.** An entirely new circular distributed by the World Trade Club, having attached to it a resolution "voted unanimously by the World Trade Club on June 18, 1919," urging that the United States Congress and the British Parliament adopt the metric system as the exclusive, legal standard.

**March to September.** Many newspapers and periodicals publish pro-metric articles and editorials based on the World Trade Club circulars, in some cases naming the World Trade Club and in others letting the articles appear as if they were original. Among the publications that "fell" for the San Francisco stuff was "Commerce Reports," issued by the Department of Commerce, which includes the Bureau of Standards, and which published the pro-metric resolution "passed unanimously" by the World Trade Club.

## Reports of Investigators.

**May 12.** A letter from the World Trade Club to New England correspondent No. 1 states:

"This movement is world wide and there are headquarters for furthering the project in New York, Brussels, Sydney, Tokio, Rome and other large cities of the world."

May 20. San Francisco correspondent No. 2 investigates the World Trade Club and writes:

"The World Trade Club is located in an office on Mission Street without any indication of its presence on the entrance door or elsewhere. A man connected with an advertising agency located there stated the funds for the work came from various societies throughout the world."

May 24. San Francisco correspondent No. 3 investigates and reports:

"Wm. E. Hague, secretary of the World Trade Club, who is also secretary of the One Hundred Per Cent Club and the Foreign Trade Club, states that the work of the World Trade Club is being financed by Mr. Z, a wealthy business man of Boston now residing at the \_\_\_\_\_ Hotel in this city. Mr. Z. is actuated solely by a desire to benefit the human race by bringing about the adoption of the metric system. It is his hobby and he has the money to gratify it."

May 28. San Francisco correspondent No. 4 investigates and reports:

"All this circularizing is financed by a rather mysterious individual named Z. He has paid about \$80,000 to one local advertising firm and the total cost to date is around \$100,000. No one at the address of the World Trade Club wanted to say anything. There are two theories about Mr. Z's purpose. He may be trying to improve the Allies' foreign trade balance by securing international adoption of the metric system, or he may be carrying out the hobby of a rich eccentric."

June 9. San Francisco correspondent No. 3 investigates and reports:

"The statement that Mr. Z. is a wealthy Boston business man is misleading, as we find that he was formerly engaged in manufacturing somewhere in Massachusetts. He is credited with being a millionaire, but however this may be, he is spending a lot of money in the prosecution of his hobby, pays his bills and asks no favors or contributions to promote the work. The above information was obtained from Mr. Hague, whom I have known well for many years and in whom I have the greatest confidence."

June 23. San Francisco correspondent No. 5 investigates and reports:

"Mr. Z. seems to have unlimited funds and pays promptly. He invariably desires to know the exact amount to be paid several days before the account is due."

June 23. San Francisco correspondent No. 2 investigates and reports:

"Mr. Z. has engaged the services of the Ramsey Mailing Co. to print, mail and distribute a vast number of circulars and this work is being paid for by Mr. Z. *The name 'World Trade Club' is adopted simply for convenience and to give more weight to the matter sent out than if it was signed by an individual. Mr. Z. is doing this work quietly and has made no effort to gain the personal publicity which might easily have been his.*"

July 14. San Francisco correspondent No. 3 investigates and reports:

"I have interviewed Mr. Z., who was the subject of our recent correspondence. Mr. Z. is devoting a large part of his private fortune in presenting to the public arguments for the exclusive use of the metric units. Literature is being sent out under the name of the World Trade Club *as a matter of convenience and to avoid the appearance of being the work of an individual, which, in Mr. Z.'s opinion, would detract from its effect.*"

#### Fake "News Items."

Aug. 11. The World Trade Club introduces a new feature into its program by sending to the press "News Items" printed in typewriter type with this "Note to the Editor": "Release

immediately. Please insert under current date." These "news items," which bear the name "W. H. Hammer, President," in addition to those of the Club and Wm. E. Hague, all relate to the pro-metric propaganda. Their value as "news items" can be judged by two of them.

One of these quotes as if it were recent a pro-metric statement by Secretary of Commerce Redfield, which I find was made by that official in a speech in Baltimore on Dec. 27, 1918, eight months previous to its appearance as a World Trade Club "news item."

In this San Francisco Club the flight of time does not affect the news value of the items in which the newspapers of the country are asked to "insert current date" and "release immediately."

For example, one of these items quotes without naming the date a pro-metric statement by Andrew Carnegie, which on investigation I find was made by Carnegie in a letter dated Cannes, France, Dec. 13, 1897, and addressed to Albert Herbert, Boston, Mass., twenty-two years preceding the date on which the editors of American newspapers are asked by the World Trade Club to "release it immediately" as a "news item," inserting "current date."

#### "A Thousand Dollars for One Word."

August 11. The World Trade Club sends to the newspapers a release-immediately-please-insert-current-date "news item," making this announcement:

#### "\$1000 Will Be Paid for a Single Word."

"San Francisco, August —. Can you create the one word which will best denote the United States and all parts of Britain? If so, you will be paid at the rate of \$1000 a word. The World Trade Club of San Francisco has offered \$1000 to the person who suggests the word which, in the judgment of the Club's Metric Campaign Committee, is best adapted to world-wide use. The World Trade Club is offering this award because in carrying on its present campaign for the adoption of metric units by all English-speaking people, it was hampered by the lack of a single short word which would express all English-speaking countries. The money will be paid to the winner at noon on May 15, 1920."

#### Fake Editorials to Influence Congress.

August 11. The World Trade Club seeks to relieve the editors of newspapers by sending them "suggested editorials on metric weights and measures." Here is the title with a few significant passages from one of the ready-made "editorials," which the editors were to use as their own in order to persuade people in all parts of the country to write to their Representatives and Senators, urging legislation to make the metric system compulsory and the English system illegal:

#### "Tell Your Legislators."

"For months past the World Trade Club of San Francisco and the Metric Association of New York have been waging a vigorous campaign for the adoption of the metric units of weight and measure by the United States.

"World Trade Club particularly has been right on the job. The copious literature issued by the club has shown with relentless logic the need for world-standardization of weights and measures, and the great gain the metric system would bring to the United States in trade, in manufacture, in education.

"Hundreds of America's most eminent men have taken the trouble to write or telegraph World Trade Club pledging support to the campaign.

"All this is very well.

"Reasons are good; but acts are better.

"World Trade Club is doing its part. But there is still an important step to take.

"It is: *to get the thing done.*

"In other words, the matter is now up to the *legislators* of the United States, particularly the *members of Congress.*

"Congress has dallied with this subject ever since the days of Thomas Jefferson.

"Our legislators lacked the 'gumption' to adopt meter-liter-gram. In 1866 Congress made the metric system legal. Why was it not made exclusive? Now is the time to remedy the error.

"Our legislators know this. They know, too, that metric standardization will remove a great handicap on commerce and education. But they need to be reminded—to be written to—to be urged to get the thing done.

"Write today. A postal will do it. *Write your Senators, your Congressman. Get the thing done. Tell your legislators.*"

August 16. Announcement by press dispatch from Washington that, because of a great popular demand, a bill making the metric system compulsory is to be introduced in the House of Representatives by Congressman A. H. Vestal, Chairman of the Committee on Coinage, Weights and Measures, and that extended hearings will be given on the measure.

### Lending Weight to the Propaganda.

Sept. 10. San Francisco correspondent No. 3 investigates and reports:

"The World Trade Club is not in any sense an organization such as the name implies, *it being merely a name adopted for the purpose of lending weight to the propaganda* such as it would not carry over the name of an individual. It is of course impossible for this to become generally known, but as the local sponsors of the movement are within their rights in making use of this title, I see no way in which it can be prevented."

### Effect of the Clamor.

Sept. 15. I call on Chairman Vestal of the Committee on Coinage, Weights and Measures, and he tells me the report of Aug. 16 is correct, that a metric bill is to be introduced in the House, the reason being the great clamor for such a bill, thousands of letters having come from all parts of the country. I ask him if he knows what is back of this clamor. "Yes," he replies. "World Trade Club?" I ask. "Yes," is his answer. "Do you know what the World Trade Club is?" I ask. "No," he replies, "but I propose to find out before I get through with it."

### Summary of the Case.

The information given above regarding the World Trade Club of San Francisco, obtained from a number of independent sources, is all in agreement and indicates that this Club is backed financially by one man, Mr. Z., whose name does not appear on any of the vast quantity of literature which has been mailed under the name of the World Trade Club; that of the two names, W. H. Hammer and Wm. E. Hague, appearing on this literature, the former is not mentioned in any of the various reports, while the latter is referred to in complimentary terms in one of the reports, and appears to be acting as a secretary of several San Francisco organizations, including the World Trade Club, in which he is evidently not the moving spirit; that the World Trade Club has expended a very large amount of money in an extraordinarily extensive mail campaign with the object of manufacturing directly and through the press a public sentiment that would lead a sufficient number of people in all walks of life and all parts of the country to bring pressure to bear on both branches of Congress at Washington and of the Parliament at London to enact legislation making the use of the metric system compulsory and that of the English system illegal; that the principal and apparently the sole financial supporter of this World Trade Club is the mysterious Mr. Z., who is reported as being actuated by a desire to benefit the human race, and who withholds his own name and conducts the propaganda under the name of the World Trade Club because it would carry more weight under that name than under the name of an individual.

It also appears that up to the present time Mr. Z.'s plan has attained a certain success in the United States. The ef-

fect of the propaganda has been such that, as Chairman Vestal admitted, enough people have written to their Representatives in Congress to create a pressure which is leading to the introduction of a compulsory metric bill and to the granting of hearings on it before the House Committee on Coinage, Weights and Measures.

### Turn on the Light.

For one I wish to enter my protest against this method of manufacturing and misleading public opinion. Before this propaganda to force the metric system on the American people and make it a crime punishable by fine and imprisonment to use our English weights and measures goes any farther, I ask the Committee on Coinage, Weights and Measures to call upon Mr. Z. of the World Trade Club to disclose his identity and give all the facts regarding his mysterious and objectionable propaganda in order that the people and their Representatives, not only in the United States, but in all English-speaking countries, may know what the World Trade Club actually is and who is or are back of it.

It may be that this San Francisco campaign is the work of only one man, who is devoting his private fortune to the propaganda in the sincere belief that it is all for the benefit of mankind. If so, the American people and their Representatives at Washington should know it, so as to be able to place the proper weight on the pro-metric influences radiating from San Francisco for the past six months.

On the other hand the mystery surrounding this World Trade Club, its lavish expenditure of money (reported at \$80,000 for one edition of its circulars, of which there have already been four) and its methods of agitation are such as to excite the suspicion that it is not the enterprise of one man, but is a deep laid scheme by a group to accomplish in 1919, when world affairs are in a state of flux, something that has heretofore been impossible, the compulsory introduction of a foreign system of weights and measures in English-speaking countries. If that is true, then the English-speaking peoples and their Representatives should know it.

Whichever of these two theories may be the truth, one thing is certain. No individual or group should be allowed to carry on a propaganda under cover of a misleading name, such as "World Trade Club," for the purpose of exciting popular clamor and by that means securing the enactment of special legislation by Congress or the Parliaments of other countries.

### End the Artificial Pressure on Congress.

The regulation of weights and measures is one of the most difficult problems of government. A mistake in the control of fundamental standards is almost certain to prove irreparable. Any proposal, therefore, to change an established system calls for a thorough knowledge of the facts, clear thinking, calm deliberation and complete freedom from the influences born of bias developed by propaganda.

Let there be an end once and for all to the artificial pressure that has been brought to bear on Congress to enact compulsory metric legislation, a pressure that for nearly twenty years has had its source in the Bureau of Standards and which for six months has been intensified by the mail campaign of the mysterious World Trade Club of San Francisco.

SAMUEL S. DALE.

Boston, Mass, Sept. 27, 1919.

### CORRECTION.

We are obliged to a correspondent who has called our attention to an error, due to a misplaced decimal point, in the silk ribbon calculation on page 24 of the September issue. The weight of the warp was given correctly as 58.5 drams, which is equal to .228 lb. instead of 2.28 lbs. Likewise the weight of the filling was given correctly as 41.8 drams, which is equal to .163 lb. instead of 1.63 lbs.

MAIN 19.

### A PROFIT-SHARING PLAN.

A plan for sharing the profits of their business with their employees has been proposed by Tootal Broadhurst Lee Co., the important English firm of cotton manufacturers. The plan, which is of special interest at this time because of the unrest among the workers and the general recognition of the necessity for a revision of the wage system, is as follows:

1. (a) "Employee" means and includes any person in the whole time employment of the Company in the United Kingdom, with the exception of Directors. (b) "Financial year" means a calendar year beginning on a first of July or on such other annual date as may from time to time be fixed by the Directors. (c) "Ordinary shares" means the ordinary shares of the Company for the time being issued. (d) Where the context admits, words importing the singular number include the plural number, and words importing the masculine gender include the feminine gender.

#### Payment of Bonds to Employees.

2. (a) If in respect to any financial year the Company shall pay a dividend or aggregate dividends on its ordinary shares at a rate (hereinafter called the dividend rate) exceeding seven and one-half per cent. per annum the Company shall pay to each employee in its service at the close of that financial year a percentage (by way of bonus) at a rate (hereinafter called the bonus rate) to be determined as hereinafter provided on the total ordinary earnings of such employee during that financial year. Sums paid for overtime work or for other special services or by way of war bonus are not included in the expression "ordinary earnings," and any portion in excess of £500 of the ordinary earnings of any employee shall be disregarded in calculating the amount of that employee's bonus. (b) The total amount of the bonuses in respect of any financial year shall not exceed the total amount of the dividends in excess of seven and one-half per cent. paid in respect of that year on the ordinary shares. (c) Subject to the preceding Clause (b) the bonus rate shall be double the excess over seven and one-half per cent. of the dividend rate, except that if the dividend rate is in excess of 15 per cent. the bonus rate and the dividend rate shall be equal. In case Clause (b) comes into operation in respect of any year the bonus rate which would otherwise be applicable under this present Clause shall be proportionately reduced. (d) The payments to employees provided for by this clause shall be made within fourteen days after the General Meeting at which the final dividend in respect of the financial year in question shall be declared. (e) This Clause is to be read subject to the provisions of Clause 3.

#### Disqualification for Bonus.

3. Notwithstanding the foregoing provisions the following shall in no circumstances be entitled to payment of any bonus except with the special sanction of the Directors. (a) An employee who has been dismissed from the service of the Company for misconduct, whether during or after the expiration of the financial year. (b) An employee who in the opinion of the Directors, expressed by resolution, has individually or in combination done anything tending to diminish the profits or damage the reputation of the Company. (c) An employee against whom a receiving order in bankruptcy has been made or who has made any arrangement with or for the benefit of his creditors or has assigned or charged or purported to assign or charge his bonus in advance.

#### Loan to Company of Sums Paid as Bonus.

4. (a) Any employee may from time to time place on loan with the Company any sum paid to him by way of bonus under Clause 2 in respect of the preceding financial year. (b) Interest will be allowed by the Company upon the amount from time to time standing to the credit of an employee's loan account at the rate of 5 per cent. per annum, and such interest will be credited to the account annually at stock-taking or in case of withdrawal on the day of withdrawal. (c) The whole or any part of the sum for the time being standing to the credit of any such account shall be repayable on 7 days' notice on either side and on the expiration of such notice shall cease to carry interest. (d) Each depositor will be furnished with a loan book which must be produced whenever any sum is deposited or withdrawn, and every deposit or withdrawal and all interest allowed shall from time to time be entered in such book by an officer of the Company appointed for the purpose, and the book shall be left with

such person to be made up when required. (e) On the closing of a loan account the loan book must be given up to the Company to be cancelled.

#### Application of Bonus in Purchase of Shares

5. (a) Any employee who at the time of any such General Meeting as is referred to in Clause 2 (c) hereof is over the age of eighteen years, and has been an employee for not less than twelve months, may within one calendar month at such General Meeting apply in writing in such form as the Directors may from time to time prescribe for an allotment or transfer to himself at par of employees' shares in the Company of £1 each to the nominal amount (excluding shillings and pence) of his bonus for the financial year then last expired, and shall (if any shares are then available for the purpose) be entitled on payment of the full nominal amount thereof in cash to have such shares allotted or transferred to him subject to the provisions of the Company's Memorandum and Articles of Association for the time being in force. Such shares when so allotted or transferred will rank for the full dividend (if any) for the then current year. (b) Any employee who at the time of any such General Meeting as aforesaid is disqualified from applying for shares by reason of his being under the age of eighteen years or of his not having been an employee for twelve months shall be entitled to be credited with interest at the rate of 7½ per cent. per annum (in lieu of the rate of 5 per cent. hereinbefore provided) on his loan account until the Annual General Meeting next after the ceasing of his disqualification, and the amount standing to the credit of his loan account at the date of the last-mentioned Annual General Meeting shall for the purposes of Clause 5 (a) be deemed to be part of his bonus for the financial year then last expired.

#### IMPORT LICENSES IN ENGLAND.

The British Board of Trade, following a statement of foreign trade policy by Prime Minister Lloyd George, has announced that, on the reassembling of Parliament, legislation will be introduced to restrict imports in order to protect British industries, following being an outline of the proposed laws:

(a) For the protection of goods manufactured in Great Britain and Ireland against dumping by taking power to prevent the sale in this country of similar goods beneath their price in the country of their origin;

(b) To enable the Board of Trade to check any flood of imports (for instance, from Germany) that might arise from a collapse of exchange so disproportionate to costs of production in the country of origin as to enable sales to take place in this country at prices altogether below costs of production here;

(c) To deal with unstable "key" industries.

The unstable "key" industries whose products are to be admitted into the United Kingdom, are scheduled as follows:

(1) All derivatives of coal tar generally known as intermediate products capable of being used or adopted for use as dyestuffs or of being modified or further manufactured into dyestuffs. All direct cotton colors, all union colors, all acid colors, all chrome and mordant colors, all alizarine colors, all basic colors, all sulphide colors, all vat colors (including synthetic indigo), all oil, spirit and wax color, all lake colors and any other synthetic colors, dyes, stains, color acids, color lakes, leuco acids, leuco bases, whether in paste, powder, solution, or any other form.

(2) Synthetic drugs (including antiseptics). (ii) Synthetic perfumes and flavorings, synthetic photographic chemicals, synthetic tannins, esters and acid derivatives or aromatic hydro-carbons, alkaloids and their salts (except quinine), and certain organic chemicals (of which a long list is given).

(3) Optical glasses, including lenses, prisms, and like optical devices.

(4) Scientific glassware.

(5) Illuminating glassware.

(6) Laboratory porcelain.

(7) Scientific and optical instruments.

(8) Potassium compounds.

(9) Tungsten powder and ferro-tungsten.

(10) Zinc oxide.

(11) Lithopone.

(12) Thorium nitrate.

(Continued on following page)



# "Straight Line" Textile Calculations

By Samuel S. Dale

Textile calculations relating to yarn and cloth are based on a few standards of measurement for length, area and weight. Volume or cubic content is not involved.

### Units of Length and Area

The inch and the yard are the standards used for measuring length and area.

Length. 1 yard=36 inches.

Area. 1 square yard=1296 square inches.

### Units of Weight

1 pound=16 ounces=256 drams=7000 grains.

1 ounce = 16 drams=437½ grains.

1 dram =27 11/32 grains.

1 pennyweight=24 grains.

### Numbering Yarn.

The size of yarn is indicated by the ratio or relation between length and weight. This relation is expressed either by the *length of a fixed weight*, as in the case of cotton yarn, of which the count or number indicates the number of 840 lengths per pound; or by the *weight of a fixed length*, as in the case of thrown silk, of which the count indicates the number of drams in the weight of 1,000 yards.

Unless otherwise stated, the count refers to the yarn as spun, or to the silk in the gum. For example, a finished cloth is said to be made of 3-run yarn if the size of the yarn was 3 runs when it came from the mule. The denier or dram count of silk yarn indicates the count of raw silk before boiling-off.

When expressing the count of ply yarn the number indicating the size is preceded by the number indicating the ply or strands of which the yarn is composed, the two figures being separated by a line. For example, "2/40s cotton" indicates a 2-ply thread composed of two strands of single No. 40 cotton yarn. This is the method used for all kinds of spun yarn, wool, cotton, linen, etc., except spun silk.

The exception in numbering spun silk yarn consists in placing the count first and having it indicate the size, not of the single yarn, but of the ply yarn. Thus "15/2 spun silk" indicates that the yarn is 2-ply and that the 2-ply yarn is equivalent to No. 15, the count of the single strand being No. 30. In like manner "10/3 spun silk" indicates that three strands of single 30s yarn have been twisted together, making the 3-ply equivalent to No. 10.

The two methods of indicating the size of yarn correspond to the two methods of indicating the weight of cloth, which is expressed either by the yards per pound, corresponding to the fixed weight system, of yarn counts, or by the ounces per yard, corresponding to the fixed length system of yarn counts. Thus "10s" applied to worsted yarn indicates length of one pound of yarn in hanks of 560 yards each, and "7-yard" applied to cotton cloth indicates the length in yards of one pound of cloth. On the other hand "5 dram" applied to thrown silk indicates the weight in drams of 1,000 yards of silk yarn; and "15 ounce"

applied to woolen cloth indicates the weight in ounces of one yard of cloth.

By the first or fixed weight method the finer the yarn the greater is the length in a fixed weight, and, consequently, the larger will be the size number.

By the second or fixed length method the finer the yarn the less will the weight of the fixed length be, and, consequently, the smaller will be the size number.

In manufacturing loose masses of textile fibers like cotton, wool, flax, etc., into yarn the material is first converted into a heavy sliver, which each successive operation makes finer. Each operation results in an increase on the length of the fixed weight. Yarn manufactured in this way is usually numbered by the length of a fixed weight.

Silk, on the contrary, is finest at the first stage when spun by the silk worm. In this form it is a very fine filament, of which one pound may measure 1,100 miles in length. In this form it is far too delicate for weaving. It must be made heavier and stronger, which is done by doubling and twisting a number of these silk cocoon filaments together.

Each successive process in the manufacture of raw silk into silk yarn makes the thread coarser. The length of the original filament remains the same. The processes of doubling thus increase the weight of a fixed length and silk yarn is numbered by the weight of a fixed length to indicate the varying weight.

Thus this size number grows larger for both spun yarn and silk as the process of manufacturing advances, although spun yarn becomes finer, and silk yarn coarser.

Silk waste comes to the manufacturer in the form of a loose, tangled mass of fibers and the yarn made from it is numbered, like cotton and woolen yarn, by the length of a fixed weight.

Following are the principal standards employed for numbering yarn by the length of a fixed weight:

	Material	Standard	
Anglo-American	Woolen	1600	yards 1 pound
World	Cotton	840	" 1 "
Anglo-American	Worsted	560	" 1 "
World	Linen	300	" 1 "
West of England	Woolen	320	" 1 "
Yorkshire	Woolen	256	" 1 "
England	Raw silk	16	" 1 "
Anglo-American	Yarn of all kinds	1	" 1 "
France	Cotton (1000 meters per ½ kilo)	992	" 1 "
Continent, metric	Woolen, worsted and spun silk (1000 meters per kilo)	496	" 1 "

The principal standards for indicating the size of yarn by weight of a fixed length are:

	Material	Standard
World	Silk	deniers per 400 aunes
	Silk	drams per 1000 yards
Anglo-American	Cotton	grains per 120 yards
	Various	grains per 100 yards
	Woolen	grains per 50 yards
	Woolen	grains per 25 yards
World	Woolen	grains per 20 yards
	Jute	pounds per 14,400 yards

There are many standards employed locally on the Continent of Europe and in other parts of the world, but they are slowly being displaced by those given above.

The above table of fixed weight systems of numbering yarn gives the length of one pound of No. 1 yarn for each, but they can also be expressed by the length of any other unit of weight. Thus the run system indicates not only the number of 1600-yard lengths per pound, but also the number of 100-yard lengths per ounce.

## IMPORT LICENSES IN ENGLAND.

(Continued from previous page)

- (13) Gas mantles and mantle rings.
- (14) Magnetos.
- (15) Hosiery, needles, latch.
- (16) Gauges.

This plan to protect British industry by the licensing and exclusion of imports can be profitably studied by those American manufacturers who think that we should admit German dyestuffs into the United States, subject only to the regular tariff rates.

# QUESTIONS AND ANSWERS

We invite subscribers to submit any questions they desire answered regarding the manufacture or sale of textile products. Any question sent to us will be answered at once if the information is in our possession. If it is not, we will submit the question to experts and their replies will be published promptly. In urgent cases we will, if practicable, send the inquirer an advance copy of the reply. Inquirers are requested to state their questions as clearly, concisely and fully as possible. This will save time and misunderstanding. The names of inquirers are held in confidence.

## FROM OVERSEER TO SUPERINTENDENT.

Editor of "Textiles":

I have been overseer of weaving for six years in a mill making both plain and fancy woolen goods. A few weeks ago our company started another mill on plain woolens and I applied for the position of superintendent of the new mill, but failed to get it because I was not "up" in calculating the cost of the goods. I would consider it a great favor if you would explain how to calculate the cost of making carded woolen cloth, as I would like to be ready when another opportunity for advancement presents itself.

FULTON (8).

Estimating the cost of woolen goods is an important calculation in a mill, but it is only a part of the textile calculations that a superintendent should understand. Fulton should study the "straight line" textile calculations that are running in each issue of "Textiles." A detailed explanation of estimating the cost of manufacturing cloth is included in this series of articles. To meet "Fulton's" immediate needs, however, we will give the following estimate of the cost of a woolen kersey. The figures, while approximately correct, should not be used by "Fulton" for estimating his goods, as the cost of a fabric should be based on the actual results obtained in the mill where the goods are to be made, or on what the manufacturer considers will be the results obtained.

We will take for illustration a piece of dyed woolen kersey, which by analysis is found to be made as follows: 2440 ends; 80 inches wide in loom, 55 inches wide finished; 36 picks in loom; finished weight 14½ ounces per yard; loss of weight estimated at 20 per cent. from picking room to woven cloth and 15 per cent. of the woven weight in finishing. The shrinkage in length in finishing is estimated at 10 per cent. The stock mixture at the picker consists of 60 per cent. wool at 58 cents a pound and 40 per cent. noils at 40 cents.

It is necessary first to have a statement of the average cost of production in the various departments of the mill in which the goods are to be made on a similar mill. For our illustration let us assume that the cost averages are as follows:

Cost of Manufacturing.

	LABOR.	EXPENSE.
Sorting Wool,	.004 per lb. grease	
Scouring Wool,	.0034 per lb. clean	
Dyeing Wool (raw stock)	.0074 per lb.	
Picking,		.001 per run
Carding & Spinning	.01 per run	
Spooling & Dressing	.056 per sect. cut	
Weaving,	Price list	
Piece Dyeing,	.005 per yd.	.033 per lb.
Finishing,	.05 per yd.	.035 per yd.
Fixed Changes,	.047 per yd. 50 pks.	.042 per yd. 50 picks

The next step is to calculate the quantity of material that must be put through each department in order to produce a cut of cloth of a given length (50 yards woven and 45 yards finished):

$$14.5 \text{ (ozs. finished)} \div .85 \text{ (100 - 15)} = 17.1 \text{ ozs. woven.}$$

$$17.1 \text{ (ozs. woven)} \div .80 \text{ (100 - 20)} = 21.4 \text{ ozs. picked stock per finished yard.}$$

$$21.4 \text{ (ozs. stock)} \times .508 \text{ cents per lb.} = \$6.79, \text{ Cost of stock per yd. finished cloth.}$$

Quantity of Material per cut of Cloth.

Wool:

$$21.4 \text{ (ozs. stock per finished yd.)} \times 45 \text{ (finished yds. per cut)} = 963 \text{ ozs. stock per cut.}$$

*A 751*

*German Kersey exported to China.*

*2440 ends 80 in. in loom 36 picks  
14½ ozs. per yd. 55 in. finished.*

*Stock Mixture*

*60 lbs. wool .58 \$34.80  
40 " noils .40 16.  
100 " .508 50.80*

*Loss, 20 per cent and 15 per cent.*

*21.4 ozs. stock .508 \$6.79 per yd.*

Process	Product	Averages	Cost per Cut		
	per cut	Labor	Exp.	Labor	Exp.
Sorting	90 lbs.	.004		.36	
Scouring	36 "	.0034		.12	
Picking	60 "	.002	.003	.12	.18
Carding & Spin.	208 Rs	.01	.001	2.08	.21
Warp Prep.	6 sec.	.056		.34	
Weaving	50 yds.	.067		3.35	
Piece Dyeing	50 "	.005	.103	.25	1.50
Finishing	45 "	.05	.035	2.25	1.58
Fixed Charges	50 "	.034	.03	1.70	1.50
				10.57	4.97
					.235 .11

*per finished yd.  
Mill Cost per finished yd.*

*Stock \$6.79  
Labor .235  
Expense .11  
Total 1.024*

*May 10, 1915.*

$$963 \text{ (ozs.)} \div 16 \text{ (ozs. per lb.)} = 60 \text{ lbs. stock per cut.}$$

$$60 \text{ (lbs.)} \times .60 \text{ (% wool)} = 36 \text{ lbs. clean wool per cut.}$$

$$60 \text{ (lbs.)} \times .40 \text{ (% noils)} = 24 \text{ lbs. noils per cut.}$$

Wool shrinks 60 per cent. in scouring.

$$36 \text{ (lbs. wool)} \div 40 \text{ (% yield)} = 90 \text{ lbs. grease wool per cut.}$$

Spun Yarn:

$$2,440 \text{ (ends)} \times 50 \text{ (woven yds.)} = 122,000 \text{ yds. warp.}$$

$$80 \text{ (inches)} \times 36 \text{ (picks)} = 2,880 \text{ yds.}$$

$$2,880 \text{ (yds.)} \times 50 \text{ (woven yds.)} = 144,000 \text{ yds. filling.}$$

(Continued on page 30)



# Knitting Department

## A WARNING TO MANUFACTURERS.

A recent report on depression in the knit goods trade in China and the closing of Chinese knitting mills carries a warning to the United States where similar causes are in operation and the same results are inevitable unless prompt measures are taken to apply the remedy. China is on a silver basis, and during the past three years the silver dollar has doubled in value from 41 cents to 82 cents in gold. This advance has had the effect of doubling the cost, measured in gold, of Chinese products, while a gold dollar's worth of foreign goods can be imported into China for just one-half the amount of silver money that would have been required three years ago.

Changes arising from similar causes and having like effects are now in progress in the United States. Owing to the great excess of exports over imports, exchange on nearly all European countries is at a discount, which means that measured in European money the United States dollar has increased in value just as the Chinese silver dollar has increased in value when measured in the gold currency of other countries. The increase in the value of the United States dollar amounts to about 15 per cent., compared with English money; 38 per cent. compared with French; 46 per cent. compared with Italian; and even more when compared with the money of the enemy nations with which the United States will again be doing business at some time in the future.

These currency changes, while due to different causes, will have the same effect in the United States as they are having in China, imposing an obstacle to the export of goods and promoting imports by reducing the domestic value of imported products. The remedy is the same in both China and the United States—protective measures to restrict imports. Unfortunately China's hands are tied. Being without an army or navy to defend herself, China not only can be robbed of Shantung, the richest part of her domain, but is not permitted to increase her tariff without the consent of foreign countries that are profiting by a low Chinese tariff. The United States is still free to regulate imports without the consent of foreign countries, and that freedom will continue to be ours if we keep out of the League of Nations.

The obstacle to our exports that is created by the depreciation of European money is an advantage to the United States because of its influence in reducing prices at home and thus tending to relieve the most serious of domestic difficulties—the high cost of living. The stimulation of imports, however, is another matter. Europe has no large stock of raw materials to ship to the United States, consequently European exports to the American market must consist almost wholly of manufactured goods, which will come into direct competition with the products of American labor. While there is yet time and the United States remains independent, let protective measures be adopted in order that the American market may be supplied by American labor. Following is the report by Consul General George E. Anderson of Hongkong

Three out of the nine well-known knitting factories of Hongkong have suspended business in the past few weeks as a result of conditions in the trade.

By far the most unfavorable factor in the present situation is the high exchange value of silver and the experience of

these Hongkong factories in operation is significant in that the same conditions apply to all industrial undertakings in China at the present time or under present conditions. While the Hongkong or other silver dollar is so high in terms of gold all local costs,—wages, rent, light, power, transportation, depreciation, interest on local capital and all,—run just about twice what they are on the basis of a normal dollar.

Aside from the materials purchased abroad it costs just as much in local currency at the present time with Hongkong dollar worth 82 cents gold to operate the factories as it did three years ago when the Hongkong dollar was worth 41 cents gold or less,—in other words doubling the gold cost of the product. On the other hand Japanese or other competition operating on the basis of a gold standard currency can operate today with substantially the same costs aside from the fluctuating cost of the yarns which all factories meet alike. Every industrial establishment in China operates under similar conditions.

So long as only local competition is faced and so long as the product is sold in China there is little or no difference in the situation but a large portion of the product of the Hongkong knitting factories has been exported to the Philippines, Straits Settlements, India and other gold standard countries and of course costs have mounted in gold with every advance in exchange. Even in competition in China, Japanese goods manufactured on a gold yen basis have the advantage of high exchange when the high priced silver dollar is translated into gold. The present high rate of exchange in China acts as an immense subsidy on foreign manufactures in competition with Chinese made goods.

In the Hongkong knitting field there have been other difficulties such as the increasing cost in local currency of labor, rents, exceedingly high electric light and power costs due to high priced fuel and transportation, and other advancing cost items.

The closing of these knitting factories is of especial interest to exporters of American yarn for they were large importers of American materials previous to the war and have anticipated renewing their relations with American exporters as soon as a supply of American yarn could again become available at fair prices.—*Consul General George E. Anderson, Hongkong.*

## TRADEMARKS IN THE HOSIERY TRADE.

A bill (H. R. 1113) to establish a standard box for apples has been introduced in Congress. In addition to fixing the size of the box this bill provides that the container shall be marked to show the quality and variety of the apples packed in it. During the hearing on the bill before the Committee on Coinage, Weights and Measures, Congressman John Reber, of Pottsville, who represents the twelfth Pennsylvania district, referred to the question of stamping the packer's name on each box and told the committee of the custom in the hosiery trade in which the jobbers object to having the goods bear the name of the manufacturers:

Mr. Reber: May I ask one question, in regard to one item I saw in here? It says the name of the packer should appear on the outside of the box. Now, in the business that I have been engaged in (hosiery manufacturing) the bulk of the business is done through jobbers, the distribution is made through jobbers and the jobbers object to the manufacturers having any mark whatever either on the goods or on the label or on the box to designate who the manufacturer was or where the goods come from. You take, for instance, the Onyx hosiery. You are all familiar with the Onyx hosiery. It is distributed by Lord and Taylor, of New York City, in immense quantities. You would naturally suppose that the Onyx Hosiery was made by Lord & Taylor, but the facts are not such at all. The Onyx hosiery is made by many hosiery manufacturers all over the United States, or Europe, for that matter, who see fit to do business with Lord & Taylor: but Lord & Taylor insist that the word "Onyx" be stamped on the goods, on the label, on the band and on the box.

Mr. Raker: And maybe there are 20 different varieties of Onyx socks?

Mr. Reber: Oh, 50 to 100, I will say.

Mr. Raker: Some good and some bad?

Mr. Reber: All qualities.

Mr. Rose: You all use Stetson hats. Stetson never made a hat in his life.

Mr. Raker: The public is being deceived?

Mr. Reber: Sure. I have made lots of Onyx hosiery and have made hundreds of side brands of hosiery for different jobbers; and so has every other hosiery mill.

Mr. Briggs: That is true of assembling parts of an automobile; they buy the parts and assemble them. Is that not so?

Mr. Reber: This is different. These people do nothing but distribute them.

Mr. Briggs: There are many distributing agencies. They buy them from other manufacturers?

Mr. Reber: As an excuse for that, I should like to say that the jobbers want to eliminate the manufacturer, prevent the manufacturer from having his brand known to the consumer or the retailer and prevent the manufacturer from going direct either to the retailer or to the consumer with his goods. So that, to protect himself, not to deceive the public, the jobber does that.

## THE MANUFACTURE OF KNIT GOODS.

BY JOHN CHAMBERLAIN.

### AUTOMATIC KNITTING MACHINES.

These machines have of recent years been greatly improved, and the latest types of machines are fully automatic in their mechanical movements, and rotate at a speed of 270—300 r.p.m. As a medium gauge machine possesses 200—220 needles, it will be understood that the stitches, although singly formed, are produced at a high speed. The machines when making heel and toes are oscillated at a slower speed, usually from 100—140 oscillations per minute, owing to the fact that individual needles are "picked" during the oscillation, as well as to the fact that oscillatory movement is of necessity slower than rotatory motion.

Two main types of machines are in common use: (1) Stationary needle cylinder machines; (2) rotating needle cylinder machines. The former are the older type of machine, and cannot be driven as fast as the latter. Moreover, they do not admit of yarn changes, with the exception of ordinary heel and toe splicing, unless rotating bobbins—*i.e.*, bobbins travelling in an orbit round the needle cylinder in co-ordination with the cams—are employed. Nevertheless, on certain classes of work, especially in the making of children's socks, they are still largely used, owing to their simple construction, low initial cost, and low renewal charges. The revolving cylinder machines are the more recent; can rotate at a higher speed owing to the driving of the well-balanced needle cylinder; admit of numerous yarn changes without rotating bobbins; have simpler devices for splicing, high splicing, and thickening the soles; but possess the slight drawback of causing the knitted fabric to rotate so that the operator cannot so readily observe defects. As, however, all the recently evolved machines work on this principle, it is evident that they must now be considered to be the premier type of machine.

All modern rotating cylinder machines possess the following fundamental parts—*viz.*: (1) Needle cylinder with sinker ring; (2) two-speed driving gear, with mechanism for oscillatory motion; (3) cam system for knitting, with automatic control of stitch length; (4) instep needle control; (5) narrowing and widening pickers; (6) yarn-changing guides; (7) splicing and high splicing mechanism; (8) timing chain and controlling drum.

These parts are constructed, positioned, and controlled in varying ways, but the machines are gradually approaching to a standard type, and there is now a great similarity in the build and definition of the machines. If the principles are thoroughly understood, it is not a difficult matter for a trained

mechanician to master any machine by ascertaining where and how the above classification of parts is arranged. For explanatory purposes a general view of one of the simplest and most largely used machines is shown in Fig. 17.

1. The frame or housing 1 of the machine is carried on legs 2, and at the top of the housing is attached the bed 3. The rotating needle cylinder 26 is screwed to the bevel-wheel 4, which is driven by the wheel 5 pegged to the shaft 6. Grooves are cut in the needle cylinder, for the reception of the needles 25. The needles have two lengths of controlling butts—short butts for the heel half and long butts for the instep half.

The butt is the part turned at right angles to the length of the needle, and it is by means of this part that the needle is given its movement by means of stationary cams. Attached to and forming a fundamental part of the needle cylinder is the sinker or web holding ring 29, which is also tricked for

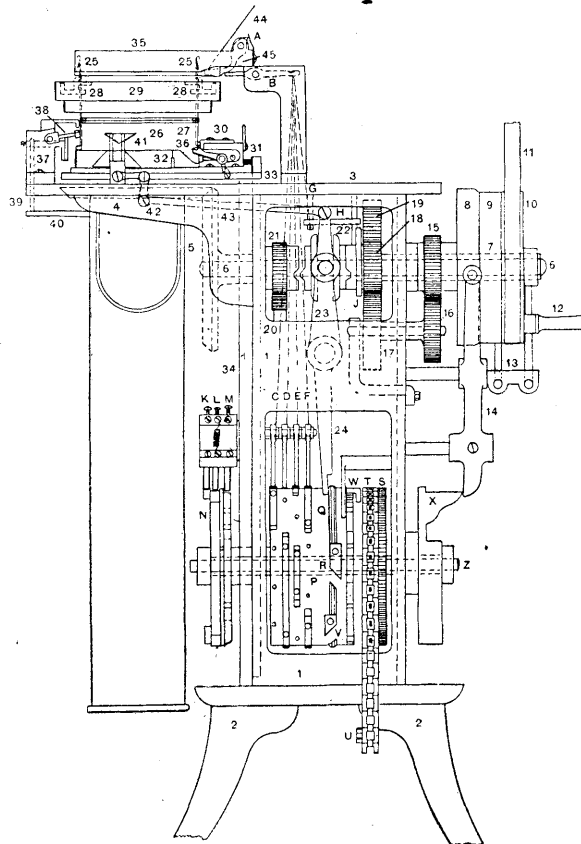

Fig. 17. Automatic Knitting Machine.

the reception of the sinkers or web holders 28. These sinkers work between the needles, and the needles draw their loops upon them; while in addition they are given a slight rectilinear movement so that as the needles rise, the loops are prevented from rising by the small catches in the upper part of the sinkers. The sinkers remain in their inward position until the loop formation is again about to occur.

No drawing-off mechanism or additional weight is required when the machine is knitting on a decreasing or increasing number of needles, and although some machines are fitted with drawing-off rollers for pulling off the tubular fabric, many machines possess no apparatus whatever for this purpose. The needles are kept in position by means of spiral springs 27, which encircle the needle cylinder, whilst the sinkers are either kept in position in a like manner or have their butts traveling in a closed cam groove.

2. The driving gear is carried on and about the main driving shaft 6, and encircling this shaft is a hollow sleeve 7, to which is screwed the slow drive pulley 9 and the pinion 18, so that a direct drive is obtained when the belt 11 is on the pulley 9.

When the belt is on the high-speed pulley 8, which is made slightly larger to ensure a tight belt, the sleeve (7) is driven through the gears 15, 16, 17, and 18, the pinion 15 being attached to the pulley 8 which rotates on the sleeve 7. Pulley 10 is the loose pulley. The sleeve 7 drives the main driving shaft 6 through the agency of the clutch hub 22, which has a sliding movement on a feather on the solid shaft 6, and when the clutch is in the position shown in the diagram Fig. 17 the needle cylinder is rotated at a high or slow speed in accordance with the position of the belt-shipper 14 and belt-fork 13.

Running freely on the solid shaft 6 is another pinion 21, which is oscillated by means of the large gear-wheel 19, the curved rack or quadrant 20, and intermediate levers (not shown). When the clutch hub 22 is moved laterally to the left it engages with the boss of the pinion 21, so that the drive from pinion 18, which is in all cases the main driving pinion, is now obtained through the gear-wheel 19, intermediate levers (not shown), and quadrant 20, whereby the solid shaft 6 is oscillated by the movement of pinion 21. From this it will be seen that all wheels, pinions, and quadrant are constantly in mesh, and are always running; but the position of the clutch hub 22 decides whether a rotatory or oscillatory drive is given to the needle cylinder and sinker ring.

3. The needle movement cams are carried on the cam block 30, which rests on the table 33, and is held close to the needle cylinder by the spring 31. On the table is a cylindrical ring 32 with up-throw inclines, so that the needles when not knitting occupy a comparatively high position, and the loops are below the needle latches. To prevent the latter from closing, either through the rise of the needle or by the centrifugal force given by the quick rotation of the needle cylinder, the needles are surrounded at their upper end by a circular latch guard 35.

The needle cylinder is open for the greater part of its circumference, so that needles may be removed and replaced at any point except where they are in actual contact with the cams. The various cam systems will be explained in detail later, but it will be seen that the stitch length is controlled in the first place by the height of the cam block, which is decided by the vertical slide 34, to which is attached a block carrying pins and adjustment screws K, L, M. Screw K gives the stitch length for the foot, screw L for the leg and ankle, and screw M for the heel and toe.

4. The instep needles, which possess long butts, are raised to a high position, in which they are clear of the cams, by means of the lower cam on the block 41. This cam acts on the long-butted needles only, and is raised by the lateral movement of the clutch hub 22 through the agency of the lever 43 and bell-crank lever 42. The upper cam on the block 41 lowers all needles to their knitting position when the clutch hub is returned.

5. Two narrowing pickers 36 are employed, and these are fulcrumed on the cam block 30, and are aligned so that at each oscillation of the needle cylinder the first of the on-coming short-butted needles makes contact with the picker 36, pushes the picker upwards and outwards, owing to the disposition of the picker fulcrum, so that it is itself raised to a high non-knitting position clear of the cams, and knitting takes place on one needle less at each oscillation during the making of the first part of the heel.

This action, which is automatically caused by the raising of the long-butted needles and the reversing of the motion, is continued throughout the making of the whole heel or toe; but in order that the knitting may be increased one loop at each oscillation during the second part of the heel or toe, a widening picker or pickers 38 carried on the block 37 are brought into action by means of the spindle 39 and lever 40 at the commencement of the second part of the heel. This

picker is shaped so that two needles are brought into knitting position at each oscillation, thus leaving the required net gain of one loop at each course, and effecting, what it is now admitted is the superior, the 2-and-1 join. On some machines two widening pickers are employed. This method is usually adopted on the machine illustrated, although a single picker cut on each side has been used. On other machines a single picker cut on all four sides has been employed, so that it can act either as a narrowing or as a widening picker. In fact, machines have been built with one, two, three, and four pickers, but the larger number is generally used on plain machines, as the control is thereby rendered simpler.

6. The yarn 44 is fed to the needles through the thread guides 45, which are held in feeding position by the spring A. The change of yarn is effected through the intermediate levers B, wires C, D, E, and F, the yarn guides which are not required to feed being raised to a height so that the needles do not receive the thread.

As the thread guide is raised the out-going yarn is cut and held by mechanism not shown. As the yarn guide is lowered the yarn is held until the needles receive it, so that the latter can draw the yarn positively from the bobbin or cone. The heel and toe yarns pass through a take-up which is controlled by a small lever situated on the instep block lever 43, but not shown, so that the movement of the clutch hub 22 to the heel or toe position automatically brings in the take-up necessary to keep the thread tight at the returning points of the oscillations.

7. In order to splice the heels and toes it is usual in this country (England) to leave the guide carrying the legging yarn in action and to lower a second yarn guide carrying a fine splicing thread; while in the U. S. A. the legging yarn is retired and a thicker heeling yarn brought in. This is effected by the ordinary yarn-changing mechanism. To high-splice heels—*i.e.*, to reinforce the half immediately above the heel—another yarn guide is requisitioned, and is operated so that it is in a low feeding position when the low or short butts pass, and in a high or non-feeding position when the high or long butts pass. This movement is given by means of a cam J carried on the pinion boss 18. The cam has high and low concentric semi-circular edges, and through the agency of the rocking spindle H and wire G gives the necessary movement. To stop this movement cams or studs are placed on the drum P when the high splicing or double sole is not being knitted. On the half where the yarn is not knitted it is left in a floating condition, and the threads are afterwards cut or torn out, as on power machines it is not safe to cut and trap the thread at each rotation.

8. In the machine illustrated the movements are timed and controlled by mechanism arranged about the lower shaft Z. Loosely mounted on this shaft is a ratchet-wheel S which is racked by a pawl (not shown) carried on a spindle attached to the quadrant. Adjoining and attached to the ratchet-wheel is a sprocket carrying a chain T. This chain has plain links, the number of which decides the number of knitting courses, and consequently the length, and controlling links which raise the pawl controller W so that a second pawl (not shown) can rack the ratched-wheel V. This ratchet-wheel is attached to the camshaft, and possesses varying lengths of teeth. A low controlling link on the timing chain causes the shaft to be racked through a small arc, a medium link through a large arc, and a high link through a still larger arc.

The relative positions of the timing and drum ratchets are important, and distinguishing marks are usually made so that the co-ordinate positions can be obtained at the commencement of each hose or half-hose. Cam N gives the correct setting of the stitch length for the foot, leg and graduated

(Continued on following page)

# Dyeing, Bleaching and Finishing

## THE PROCESS OF CARBONIZING.

Fig. 21 shows a German machine adapted for carbonizing both raw stock and piece goods. It consists of an iron framework covered with sheet iron and forming a rectangular chamber. When raw stock is to be carbonized the wool is spread in drawers which are placed in the machine, as shown in the illustration, the front of the machine being provided with a double door to allow the drawers to be inserted and removed.

When pieces are to be carbonized the cloth which has been previously soaked in the acid solution is run into the

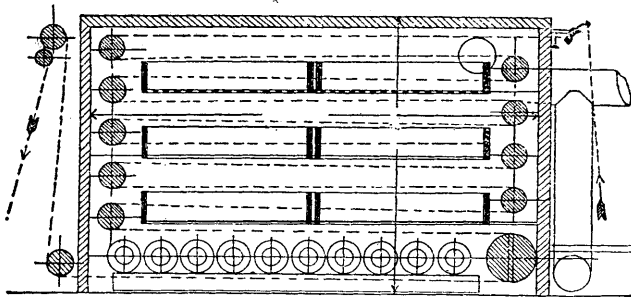

Fig. 21. Carbonizing Machine for Wool and Piece Goods.

machine in the open width, passing over the rolls from the top of the machine to the bottom, finally being delivered by the press rolls, shown in the illustration.

When carbonizing raw stock the air valves are arranged so that the moist air will be carried from the machine during the preliminary drying of the material. When the wool is dry the valves are closed and the heat kept in the machine so as to raise the temperature to the carbonizing point, the fan passing the air continuously over the heater.

Fig. 22 shows a carbonizing machine for piece goods which is built at Aix la Chapelle. The cloth passes to the top of the machine and then back and forth lengthways over rolls, as shown, to the bottom, during which passage it is dried and carbonized. The fan *V* forces the air from the heater *h* through the pipe *r* from which it passes through openings in the front of the machine into the drying chamber. The machine is so constructed that the drying chamber is completely shut off from the outside air down to the opening *k* under the cloth which is being delivered from the machine. The wall *w* at the back of the machine incloses only the lower layers of the cloth. A pipe leads from the wall *w* to

## THE MANUFACTURE OF KNIT GOODS.

(Continued from previous page)

ankle, and heel and toe. The center part of the cam *N* effects the cutting and trapping of the outgoing threads, while an internal cam groove, represented by dotted lines, controls the action of the widening pickers.

Drum *P* carries cams or studs to regulate the yarn changes, the cams or studs being screwed in the correct position, as indicated in the diagram. The clutch hub *22* is operated and controlled from the head *Q*, and the adjustable parts *R* through the agency of the levers *24* and *23* and an intermediate spindle. The position of the belt slipper is controlled by the cam *X*. The machine can be turned by hand through the agency of the handle *12* which is attached to a crank screwed to the sleeve *7*. The hose, as knitted, pass down the fabric tube *Y*, which keeps them in position during their rotation.—*Textile Manufacturer, Manchester, England.*

the fan. The upper layer of the cloth which is not enclosed by the wall *w* is exposed to the outside air. The sides and bottom of the drying chamber are closed in.

Between the bottom *b* and the cloth is an opening *k* which extends across the width of the machine. The cloth passing over the rolls back and forth from one end of the machine to the other forms pockets or sacks *s* into which the air enters through the openings *d*.

The hot air is forced by the fan through these openings *d* into the upper pockets and through the cloth, as there is no other way in which to escape. The arrow shows the direction in which the air moves. The air passing through the upper layers is heavily loaded with moisture and passes out of the machine through the open top. In order to assist in removing the air, a small fan *v* is used. The air that passes down through the cloth is carried through the pipe at the back of the machine into the fan and used over again for drying purposes. A new supply of air to take the place of that which is driven out of the machine is obtained through the opening *k*, passing to the other end of the machine over the full width of the cloth. In this way the hot air which is not loaded with moisture is mixed with the fresh air into the machine, and thus serves to dry the cloth more rapidly. The advantages claimed for this machine are the economy of heat, rapid drying and an improved handle of the goods.

## WET FINISHING OF WOOL GOODS.

In the finishing of woolen goods the wet processes are of the utmost importance. If the wet work is not well done it will be impossible to finish the goods properly. Difficulties that sometimes develop in the dry finishing and which the inexperienced finisher might think could be corrected there, often originate in the wet department where the remedy must be found. Goods that are not properly fulling and thoroughly cleaned cannot be properly gassed and sheared and are very likely to lack the handle and snappy appearance of a well finished fabric.

A greasy smell is not the only indication that the goods are not thoroughly clean. Cloth may be free from grease and yet contain a residue of soap or loose dye that will cause an objectionable odor and handle. Even when the goods are thoroughly cleansed in the scouring process, defects in the soap in the fulling will result in imperfect felting and a clammy feel when finished. When the fulling soap is right, all the foreign matter is taken up by the soap solution and carried off during the rinsing process.

I was once called to take charge of the finishing in a mill where the condition of things and the remedy applied showed the importance of soap in fulling. The goods were heavy weight cassimeres of medium grade. The man in charge of finishing had been requested by the superintendent to remain a few days to show me around. I was not a little surprised to find he was an old acquaintance with whom I had at one time been associated in the dry finishing department. I knew he had never had any very extended experience in the wet department.

The goods were largely of black, brown and blue grounds, with fancy effects of red, orange, peacock blue and mixtures. Upon examination I found there was a variation in shade and finish from side to center. For several inches on each side the cloth was teathy or threadbare, changing gradually

to a dull felted and muggy appearance in the center of the piece. The sides seemed to be overlapped and sheared, while the selvages in some cases were tender.

The fancy colors were dull and the fabric had a clammy feel. There was a large quantity of the goods on hand, shipment having been stopped because the commission house required the eight pieces in each case to match in shade, with a sample of the shade attached to the invoice. Owing to the wide variation in shade it was impossible to make up a case on that plan.

My predecessor claimed that the variation in the shade of different pieces was due to a variation in the picks and the weight from the weave room, and that the difference between the sides and the center of the cloth was due to uneven napping, which he was trying to remedy.

He first called on the mechanic to true the gig cylinders. As the mechanic could not see that they were out of true, there was nothing for him to do. Then the finisher conceived the idea of putting new teasels in the middle of the gig slats, leaving old ones at the ends, so as to gig more in the middle of the cloth, where it seemed to be needed. He also lagged the middle of the iron rolls on the rotary gig with strips of cloth to press the center of the piece against the cylinder.

I found the fulling soap became thin and watery during the fulling operation, instead of having a firm body. There was no indication of a lather during the washing, and the time allowed for rinsing was much too short. I increased the alkaline strength of the fulling soap 10 per cent. and used 5½ ounces of soap in place of 4 ounces to the gallon. I ordered the pieces to be run 40 minutes in the rinsing bath, so as to remove all the soap discharged. When the goods handled in this way were gighed, I removed all the laggings that had been put on the rolls and supplied the cylinder with slats having a uniform grade of teasels all the way across. Then I proceeded as though there had been no difficulty, and found that the shear cut the cloth evenly all the way across, there being no variation in the shade of the pieces. The sides and selvages were strong and the shading from side to center was perfect.

The difficulty with the goods had been caused by defects in the fulling and scouring processes. The cloth was fairly clean along the sides, as is apt to be the case when goods are imperfectly scoured. In the endeavor to clear up the middle of the cloth in napping and shearing the sides had been overdone and made tender. As soon as the cloth was thoroughly clean, all portions were affected uniformly by the gigning and shearing and the finish was uniform and perfect.

MEDIDA.

### PRINTING VIGOUREUX WORSTED.

The illustration shows a gill-box arranged for printing different colors on worsted sliver for the production of mixed yarn, the process having been recently patented in this country. A sliver passing from the gill-box is conveyed to the dabbing device by conveyers 17 and 18. It then passes over a roller 5 which is permanently in contact with a color distributing roller 6 partly immersed in a color trough 7. A roller 8 removes the excess of color from the roller 5. The sliver 1 is brought into contact with the roller 5 from time to time by a reciprocating plunger 9 mounted adjustably on a spindle 10 which is reciprocated from a crank on the shaft of a gear wheel driven by gearing 12, 13, 14, 15, from a shaft 16, not shown. An apron conveys the sliver to a receiving truck.

In another arrangement a pad having an inked surface descends from time to time upon the sliver as it passes under it. This pad receives fresh supplies of color from an

inking roller passing over its surface from time to time or in any other suitable manner.

Either the printing surface itself or the abutment member acting as a counter-surface, between which surfaces the fiber is temporarily held during printing, may be elastically mounted, either pneumatically or on springs, in order to yield resiliently to the printing impression or blow.

One or more of such printing devices may be arranged

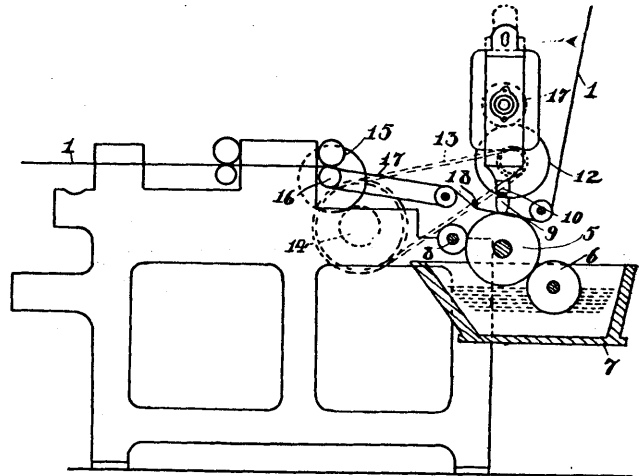

either in series or in parallel to one another, acting on the band of combed fiber, or one or more of said devices may be arranged to act on parallel bands of combed fiber, which may then move on to subsequent requisite processes to form mixed colored yarn.

### WASTE OF STEAM IN DYEHOUSES.

BY W. P. GOODALE.

Very few of the overseers in the dyehouses pay any attention to the steam used in their dyeing processes. The waste of fuel does not make any material difference to them. A dyehouse full of escaping steam, with clouds of same rising from every open dyeing machine, seems to indicate industry and a successful dyehouse.

The progressive dyer, however, realizes that it is a costly proposition to let the atmosphere absorb a large share of the coal pile. In many cotton mills where goods are dyed at a boil, as well as in many woolen and worsted mills, very few dyehouse overseers realize that no matter how much steam is forced through the open dye bath, the highest temperature that is possible to get is 212°. They may be using enough steam in one machine to supply three machines. Excess steam in the atmosphere means a total loss in dollars and cents and should be directly charged up to lack of knowledge of the textile process.

In the dyeing process temperature is, of course, very essential and should in all cases be controlled. With the large number of thermostatic devices on the market for regulating the amount of steam used there is no reason why the atmosphere around each open dyeing machine should absorb steam that has done no useful work. Every dyeing machine should be equipped with a thermostatic temperature controller of reputable make, no matter what temperature is required. With a device of this sort the steam valve will close at a boil, shutting off the excess steam that fills the air, and makes the average dyehouse a damp and disagreeable place to work in. Conditions in the average dyehouse should be controlled in order to contribute to the health and welfare of the workers. Buy less fancy fixings for the office and more common sense steam and health preserving devices for the dyehouse.

All pipes in the dyehouse should be covered with the best

(Continued on page 32)

# THE SCIENCE of KNITTING

A Reference Book of  
Great Practical Value for  
Knitting Mill Men : :

"The Science of Knitting" consists of 330 pages, and contains a vast amount of desirable technical information regarding the various branches of the knitting industry. Durably bound and of convenient size.

Mailed postpaid on receipt of the price, \$3.00, by

**"TEXTILES"**

79 MILK STREET - BOSTON, MASS.

## NEW PUBLICATION.

Manufacturer of Linen, Hemp and Jute Fabrics; by H. R. Carter; 86 pages  $5\frac{1}{2} \times 8\frac{1}{4}$ ; John Bale, Sons & Danielsson, London; price, \$1.75.

The author of this volume gives in brief compass much useful information on the machinery and processes of manufacturing linen, hemp and jute fabrics, which is arranged under the following heads: History of industry; preparing the warp; preparing the weft; the loom; figure weaving; motions of the loom; double, treble and tubular weaving; cloth construction; weaving calculations; automatic looms, stop-motions, etc.; cropping, beetling and calendering; factory construction, ventilation and humidification.

## FROM OVERSEER TO SUPERINTENDENT.

(Continued from page 24)

122,000 (yds. warp) + 144,000 (yds. filling) = 266,000 yds. yarn.

Take-up and waste estimated at 20 per cent.

266,000 (yds. yarn)  $\div$  .80 (100 - 20) = 332,500 yds. per cut.

332,500 (yds. yarn)  $\div$  1,600 (yds. per run) = 208 runs per cut.

Warp dressed in 6 sections.

Woven 50 yards per cut.

Finished 45 yards per cut.

The next operation is to estimate the cost of material and manufacturing per finished yard from the data already obtained. This estimate is shown in the accompanying form in which it may be written in the cost book used for that purpose. Estimating the cost of textile goods is like all mathematical operations,—more difficult to explain than to perform. When the process is once clearly understood, the cost of a given fabric can be estimated in a very short time.

## RECENT TEXTILE PATENTS.

- Air and gas washers and the like, Nozzle-flushing mechanism for. 1,312,721. W. H. Carrier, Buffalo, N. Y.
- Air-moistener. 1,312,948. E. J. Bushey, New York.
- Braid, Machine for forming tatting. 1,313,439. H. H. West, Plymouth, Pa.
- Carding-machines, Collecting mechanism for. 1,312,953. W. E. Cook, New York.
- Carding-engine. 1,314,586. D. Grosjean, Verviers, Belgium.
- Combing-machine. 1,316,376. E. S. Maynard, A. M. Ashcroft, and A. E. Fletcher, Preston, England.
- Drying hanks or warps of yarn, woven or felted fabrics, leather, and fibrous material, Machine for. 1,312,348. T. Ogle, Bramley, near Leeds, England.
- Fabrics, Inserting openwork in. 1,313,198. C. and A. Marchese, Brooklyn, N. Y.
- Fabric. 1,315,179. F. A. Butler, Danvers, Mass.
- Fabric-steaming device. 1,314,791. H. M. Dudley, Philadelphia, Pa.
- Fabric-clamp. 1,316,387. B. F. Orewiler, Chicago, Ill.
- Fabrics, Machine for introducing knickers into. 14,724. W. S. Kinsley, Reading, Mass.
- Fibrous stock, Cleaner for. 14,725. W. S. Kinsley, Reading, Mass.
- Garnetting-machine cleaner. 1,311,293. G. Schaefer, Worcester, Mass.
- Hose drier and stretcher. 1,313,169. J. Domecq, Los Angeles, Cal.
- Hosiery. 1,314,356. E. Nordblad, South Bend, Ind.
- Hemp-gatherer. 1,311,407. E. Lawson, El Dorado, Wis.
- Jacquard-machine. 1,312,779. F. Duchacek, Paterson, N. J.
- Knitting-machines, Tuck-stitch mechanism for. 1,311,623. R. W. Scott, Boston, Mass.
- Knot-tying device. 14,697. A. B. Edmands, Pawtucket, R. I.
- Knitting-machine needle-dial. 1,314,377. H. Swinglehurst, Orange, N. J.
- Knitted webs, Machine for uniting. 1,315,064. L. N. D. Williams, Ogontz, Pa.
- Knitted cap. 1,313,080. L. H. Ensten, Cleveland, Ohio.
- Loom attachment. 1,313,149. A. S. Poole, Danville, Va.
- Looms, Pile-cutting mechanism for. 1,314,917. A. Veluard, Philadelphia, Pa.
- Loom-seat. 1,312,251. R. Jamieson, Hopedale, Mass.
- Looms, Beam-locking device for. 1,312,269. A. E. Rhoades, Hopedale, Mass.
- Loom for beadwork. 1,313,765. D. Traum, New York.
- Loom for weaving. 1,316,159. T. T. Jackson, Broadbottom, near Manchester, England.
- Loom-shuttles, Thread-eye for. 1,315,946. F. Cass, Brooklyn, N. Y.
- Looms, Feeler mechanism for. 1,316,059. W. W. Quinton, Northbridge, Mass.
- Looms, Feeler mechanism for. 1,316,060. W. W. Quinton, Northbridge, Mass.
- Looms, Bobbin or quill cleaning attachment for. 1,312,750. G. H. Redmond, Griffin, Pa.
- Looms, Harness-motion for. 1,312,751. A. E. Rhoades, Hopedale, Mass.
- Looms, Warp-delivering means for. 1,312,847. J. Hirst, Melrose, Mass.
- Loom, Hand. 1,313,596. C. Hendrick, New York.
- Looms, Feeler-motion for. 1,313,349. E. S. Stimpson, Hopedale, Mass.
- Looms, Feeler-motion for. 1,313,350. E. S. Stimpson, Hopedale, Mass.
- Looms, Stop-motion for. 1,313,755. J. Stuer, Methuen, Mass.
- Loom feeler-motion. 1,311,747. A. Blouin, Holyoke, Mass.
- Looms, Harness stop-motion for. 1,311,767. R. H. Gelinas, South Hadley Falls, Mass.
- Shuttle. 1,312,666. B. S. Atwood, Milford, Mass.
- Silk and silk-wastes, Producing foam or froth for ungumming. 1,313,235. P. Schmid, Basle, Switzerland.
- Spinning-frame. 1,313,164. F. Casablanca, Sabadell, Barcelona, Spain.
- Spinning or winding machine. 1,315,973. H. A. Leonard, Hopedale, Mass.
- Stocking. 1,311,255. R. Thierfelder, Milwaukee, Wis.
- Thread or yarn tension device and clearer. 1,311,448. F. A. Holt, Rochdale, and G. Kershaw, Whitworth, England.
- Textile apparatus. 1,312,874. J. W. Roberts, Passaic, N. J.
- Textile fabrics, Process and apparatus for producing smooth-surfaced coating on. 1,313,655. E. Weinheim, N. Y.
- Textile-machine. 1,313,294. E. F. Hathaway and C. Lea, Boston, Mass.

## One Branch of a Giant Industry

**T**EXTILES comprise fabric and color. The fabric is right when the color is right. They stand or fall together. This is why the dyestuff producer must consider his work as a factor in a larger industry.

The textile industry is a great industry. Its annual output is valued at more than one billion dollars. But it is singularly dependent upon the dyestuff producer. Fabric without color is unthinkable.

The National Aniline and Chemical Company, Inc., recognizes this relation to the textile consumer. It is here to serve the textile industry. It is dependent upon that industry for encouragement and for existence. If it does not serve that industry adequately it will have no reason for existence.

The production of dyestuffs is a share in the work of a giant industry.

**National Aniline & Chemical Company**  
INCORPORATED

21 Burling Slip, New York

Works: Buffalo

Brooklyn

Marcus Hook



# Dyestuffs and Chemicals

## H. A. METZ & CO.

INCORPORATED

122 HUDSON STREET  
NEW YORK CITY

BOSTON CHICAGO  
PHILADELPHIA PROVIDENCE  
ATLANTA CHARLOTTE  
SAN FRANCISCO



*In hoc signo vincimus*

### DYE EXCHANGE CORPORATION

*Clearing House for Colors*

141 BROADWAY, NEW YORK

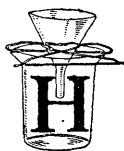

## HELLENIC COLORS

Choicest Collection of Dyes, Dry Colors  
and Oil Soluble Colors available anywhere.

Based on European Standards Priced Below Average Market

Specialties: Malachite Green Crystals—Fuchsine  
(Magenta) Crystals—Methyl Violet Crystals and All  
Other Basic Colors, Direct Colors and Acid Colors

### HELLENIC CHEMICAL & COLOR CO.

INCORPORATED

1 Cedar St.

New York City

### WASTE OF STEAM IN DYEHOUSES.

(Continued from page 29)

grade of insulating material. The best is none too good when the enormous losses from uncovered pipes are taken into consideration. When repairs are made in the dyehouse the pipes are frequently left bare, causing great waste of heat, which means money. Very few dyers are aware of the loss of heat from radiation and problems of this sort are usually left to some one else. A dyer should be as particular about the cost of operating his department as he is about bringing the goods out right.

The dyehouse usually being some distance from the source of steam supply, there is in many cases a large amount of condensation during the passage of the steam to the dyeing machines. Efficient devices are on the market for reducing this condensation to a minimum, which is great advantage to the dyer as it prevents the weakening of the dyebath by the addition of the water of condensation. Dyers should become acquainted with the amount of condensation in the steam pipes and act accordingly.

Walk through any dyehouse and wherever you find excess steam in the air over open dyeing machines remember that no matter how much steam is being forced through the bath, a temperature of 212° is all that is possible to obtain. There are tremendous heat losses in every dyehouse where this subject has not been taken into consideration.

### BRITISH DYESTUFF SITUATION.

British authorities propose to take under the terms of the peace treaty only such German dyestuffs as cannot be obtained or more in Great Britain, and in the importation of these a rationing scheme will be employed, the provisions of which will be applicable to individual firms as well as to the countries of the associated powers.

The British Government has made strenuous efforts to build up the dye manufacturing industry in this country and has subscribed for £1,700,000 (\$8,273,000) worth of the stock of the British Dyestuffs Corporation, a £10,000,000 concern, which has just been formed to exploit and co-ordinate the dye industry of Great Britain. Concerning this new corporation, the London Times said recently:

"The issue of the long-expected prospectus of the British Dyestuffs Corporation, signaling the completion of the amalgamation, should have an almost immediate good effect on output. The constant negotiations and debates have been unsettling and have interfered with work to some extent. Now there is nothing to interfere with the steady routine of research and actual production, and progress may be expected at a greatly increased rate. With all the advantages of amalgamation there will still be a healthy rivalry. Blackley will vie with Huddersfield, and it is all to the benefit of the color consumer that there should be this interdepartmental competition."—Consul General Hollis, London.

### TWO NEW DYES.

The National Aniline & Chemical Company, Inc., announces the production of two new dyes, known as Erie Yellow Y and Wool Blue C. B.

Erie Yellow Y is a direct color practically identical with the pre-war type, Chrysophenine, and fills a big gap in the line of direct colors. It is of value not only as a cotton color, but also as a color for wool and union goods.

Wool Blue C B is identical with the pre-war color Azo Wool Blue C, and similar to Azo Acid Blue B. It is of special value in the dyeing of worsted goods with silk effects, as it leaves silk white when dyed with Glauber's Salts and acetic acid. This is the first bright blue of a reddish shade manufactured by the National. It will also find extensive use on yarns and ladies' dress goods.



**FAST VAT DYES**

MADE BY  
**THE SOCIETY OF CHEMICAL INDUSTRY IN BASLE, SWITZERLAND**

Sold in America during the whole period of the war by  
**A. KLIPSTEIN & COMPANY, New York**  
 and obtainable now in rapidly increasing quantities

**THESE DYES ARE FASTER THAN INDIGO**

They are sold under the trade name of  
**"CIBA" and "CIBANON" DYES**

and include every necessary shade of color — for example — "CIBA" Blue, Violet, Yellow, Red, Scarlet and Bordeaux  
 "CIBANON" Green, Yellow, Orange

The Textile Trade of America need not suffer for the lack of  
**FAST VAT DYES**

Quotations and samples on application  
**A. KLIPSTEIN & COMPANY**  
 644 GREENWICH STREET, NEW YORK CITY

**JACQUES WOLF & COMPANY**

MANUFACTURING CHEMISTS AND IMPORTERS

<p>ALL SULPHONATED CASTOR OILS                  FINISHING PRODUCTS                  For Cotton, Wool and Silk.  <b>BENSAPOL</b>                  For Scouring Wool.  <b>BLEACHING OIL</b>                  Special Product for Bleacheries.  <b>BOIL-OFF OIL</b>                  For Degumming Silk.  <b>GUMS</b>                  Arabic, Karaya, Tragacanth, Textile.</p>	<p><i>Main Office and Works</i>  <b>PASSAIC, N. J.</b>                  ◆  <i>New York Office</i>  <b>100 WILLIAM STREET</b></p>	<p><b>MORDANTS &amp; CHROME COLORS</b>                  For Fabric Printing.  <b>HYDROSULPHITES</b>                  (for all purposes)                  Stripping, Discharge Printing, Vat                  Colors and Indigo Discharge.  <b>ALIZARINE YELLOWS</b>  <b>FAST GREEN PASTE</b>  <b>CHROME BLACK</b>  <b>MONOPOLE OIL</b>                  U. S. Pat. 861397 Serial 367303.</p>
--	--	--

WESTERN REPRESENTATIVES

UNITED INDIGO & CHEMICAL COMPANY, Ltd., 218 West Kinzie Street, Chicago, Illinois

**PROVIDENCE DYE WORKS**

PROVIDENCE, RHODE ISLAND

*Dyers of Cotton Yarn  
 in skeins*



Yarns Wound  
on Cones and  
Tubes

Our Customers  
Recommend Us to  
Their Friends



# Atlantic Blacks

Our list of Sulphur Blacks now includes:

**ATLANTIC BLACK B EXTRA**, a Jet Black of unequalled shade and intensity, especially suited for dyeing hosiery, skeins and warps. This mark has comprised our chief production to date.

**ATLANTIC BLACK G EXTRA**, a Greenish Black, particularly suited for warps in union fabrics to be cross-dyed.

**ATLANTIC BLACK R EXTRA**, a Reddish Black, recommended for dyeing raw stock, where covering power, and not shade, is the chief consideration.

All the above Blacks possess the unrivalled "ATLANTIC QUALITY."

## ATLANTIC DYESTUFF COMPANY

WORKS  
BURRAGE, MASS.

SALES OFFICES

Philadelphia	Boston	New York
1530 Real Est. Tr. Bldg.	88 Ames Bldg.	230 W. Thirteenth St.
	Chicago	
	227 W. Randolph St.	
Charlotte	Providence	
706 Com. Nat. Bank Bldg.	334 Westminster St.	

### DEVELOPER FOR DYED FABRICS.

A process for developing blacks after preparation in an acid bath has recently been patented. The inventor states that it is particularly adapted for the so-called direct dyes, which as ordinarily applied give unstable colors. By the use of the new developer with a direct dye a black or brown can be obtained equal in fastness to the well known Zambesi black and with a superior luster, the process having a less deleterious effect on the fabric than is the case with Zambesi black. The new process, it is claimed, is suited not only for the amido group of dyes, with which it gives a superior color and finish, but for practically any developed color. The improved process is carried out with a direct dye, such as diamine black B O, as follows: After dyeing with the direct dye in the usual way, the fabric is treated for fifteen minutes in the acid or diazotizing bath prepared as follows:

½ pound sodium nitrite (crystal form).

½ pound sulfurous acid or sulfuric acid.

100 gallons water.

The bath is used at the room temperature, the quantity given above being for 100 pounds of material.

The superfluous materials are then washed out of the fabric with cold water and the fabric is subjected to the developing bath. This should be done promptly since light affects the fabric when in this condition. This developing bath is prepared as follows:

80 gr. acetic acid 30 per cent.

80 gr. chloroform.

80 gr. zinc acetate.

10 gr. aqua ammonia 26 per cent.

880 gr. cold water.

5 lb. beta naphthol.

1 lb. alpha naphthylamin.

3 lb. phenol (crystallized).

8 lb. caustic soda.

The mixture is heated until the materials are dissolved, and 75½ pounds sodium chloride is slowly added and thoroughly mixed. Then 5 pounds nitric acid or hydrochloric acid is slowly added. The whole is then cooled off and pulverized, resulting in 100 pounds developing material. Four to eight ounces of this developing material is diluted in sufficient boiling water to form a solution, to which is added sufficient cold water to overflow the hundred pounds of fabric heretofore mentioned.

The acid prepared fabric is allowed to remain in the developing bath for about fifteen minutes during which the shade changes to a deep green black, the color is permanently set and the high luster finish is given. The fabric is then removed from the bath and is rinsed in warm or hot water and soap to remove the superfluous developer and any other loose foreign matter, this also testing the fabric for permanency of color.

### NEW DYES.

The National Aniline & Chemical Company, Inc., recently announced the production of two new dyes, known as Niagara Blue G Conc. and Sulphur Brown 3 R.

Niagara Blue G Conc. is a direct color practically identical with the pre-war type, Benzo Azurine G. It is fairly fast to light, good to washing, and fast to organic acids. An after-treatment with copper sulphate renders the shade somewhat greener, but materially increases its fastness to light and washing. Because of its level dyeing properties, good solubility and rich shade, Niagara Blue G Conc. will find extended use in the dyeing of all classes of cotton material.

(Continued on page 43)

# Newport Dyestuffs

Made in the U. S. A. Immediately Available



Trade Mark

New  
Products



Trade Mark

## NEWPORT SULPHUR INDONE 2 R

The brightest Sulphur Blue on the market.

## NEWPORT DIRECT BLACKS—E EXTRA—EE EXTRA—2 G

High concentration and good value

## NEWPORT DEVELOPED BLACK S C

For silk and cotton hosiery, dyeing both fibres the same.

## NEWPORT DEVELOPED BLACK B H

## NEWPORT DIRECT FAST BROWN M

## NEWPORT NEUTRAL GREY G

## NEWPORT DIRECT FAST YELLOW N N

Corresponding with pre-war standards

# Newport Chemical Works, Inc.

OF DELAWARE

PASSAIC, NEW JERSEY

BRANCH SALES OFFICES

Boston, Mass. Philadelphia, Pa. Greensboro, N. C. Chicago, Ill.  
Providence, R. I.

**MILL NOTES.**

The Cash Mills is a new corporation at Gaffney, S. C., incorporated with \$300,000 capital to build a 25,000 spindle cotton factory and mill village. E. R. Cash, W. C. Hamrich and D. C. Rose are some of the interested parties.

The Booth Manufacturing Co., New Bedford, Mass., is to build a new \$30,000 office building.

The Wachusett Woolen Mills, Hubbardston, Mass., formerly called the Hygienic Mills, have been reopened, with M. J. Shaughnessy of Worcester as superintendent. The new owners of the plant are Samuel H. Niman, president and treasurer, and Mr. Niman's Sons, Max and Morris. Woolen cloth is to be made.

A large addition to the Zollinger & Schroth Silk Mill, Allentown, Pa., is about to be built.

William Tafts, agent of the Lancaster Mills, Clinton, Mass., has resigned and taken a position with Lockwood, Greene & Co., Boston, who own the mills. L. E. Billington, superintendent of the Lancaster Mills, and Earle L. Fuller, assistant paymaster, have also resigned.

The Willington Mills, spool cotton manufacturers, So. Willington, Ct., are building a three-story bleachery.

The Clemens Silk Co., of Archbald, Pa., will erect an addition to their plant. The plant produces furrier lining and tie silks.

Morris Jacob and Samuel Kuchinsky, of Passaic, N. J., are having plans prepared for the erection of a four-story silk mill.

The Star Worsted Company, of Fitchburg, Mass., are erecting an addition to their present wool sorting room.

The Island Woolen Co., of Baraboo, Wis., will in the near future erect a large addition to their plant.

The Pacific Woolen Corporation is planning to erect a large plant at Oakland, Cal.

The French Worsted Co., Hamlet Avenue, Woonsocket, R. I., will erect the proposed boiler room and an oil reservoir.

The Patrick-Duluth (Minn.) Woolen Mills will in the near future erect an addition to their plant.

C. W. Causey, Greensboro, N. C., and J. L. Scott, of Graham, N. C., are planning to erect a cotton mill.

The Statesville (N. C.) Cotton Mills are erecting a new dyehouse which will greatly increase the capacity of the plant.

The Shelby (N. C.) Cotton Mills have awarded a contract for the erection of an addition to their plant.

# BLEACHERS!

Better bleaching is wanted by the Public, by the Selling Agent and therefore, by the Mill.

It costs nothing to get the dope from us about Peroxide bleaching.

Inform yourself. See how simple and safe it is and that it does not cost any more.

After that: Show it to the boss.

He'll be glad and he'll prove it.

THE ROESSLER & HASSLACHER CHEMICAL CO.  
New York, N. Y.

## S. R. DAVID & COMPANY, Inc. DYESTUFFS, CHEMICALS, Etc.

Telephone Main 1684

100 PURCHASE ST. - - - BOSTON, MASS.

FACTORY: DYE PRODUCTS & CHEMICAL CO., Inc., NEWARK, N. J.

Well equipped Laboratory for matching and testing

# MERION WORSTED MILLS

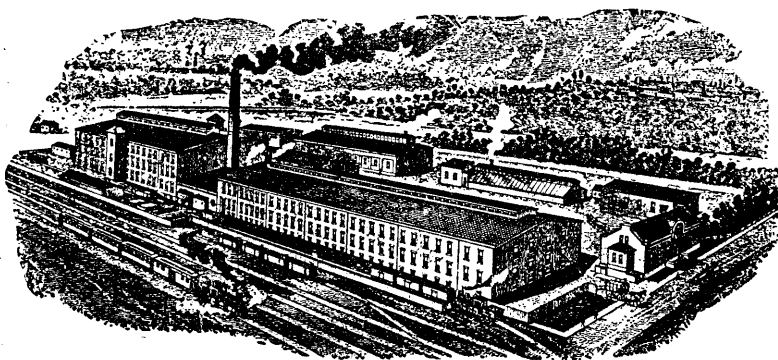

SELL DIRECT

## Fine French-Spun Worsted and Worsted Merino Yarns

WHITE NATURAL AND FANCY MIXES IN SINGLE  
AND PLY FOR KNITTING AND WEAVING

Mill and Office  
WEST CONSHOHOCKEN, PA.

## SPUN SILK YARNS

MADE ESPECIALLY FOR KNITTING AND  
HOSIERY

In the Grey or Dyed on Cones as Wanted.

American Silk Spinning Co., Providence, R. I.

WE ARE OFFERING AN

## ARTIFICIAL SILK YARN

ADAPTED TO THE KNIT GOODS TRADE

ALSO REAL SILK

SAMPLES AND QUOTATIONS ON APPLICATION

MINDLIN & ROSENMAN

105-107 EAST 29th STREET,

NEW YORK

## AN INVALUABLE BOOK FOR WOOLEN AND WORSTED MANUFACTURERS

### "COST FINDING IN WOOLEN AND WORSTED MILLS"

By *SAMUEL S. DALE*

NO manufacturer of woolen and worsted goods can afford to be without a copy of this work.

What the "Textile Mercury," Manchester, England, says:

"Cost Finding in Woolen and Worsted Mills" is packed full of ideas. In particular, the method of costing based upon standard yards of so many picks per inch is explained. This is a method that is now followed by many of the best weaving concerns in this country, and certainly seems to be the most reasonable. The principles outlined are illustrated with actual productive figures of several American mills. Not only do we recommend this book to woolen and worsted manufacturers, but also to others whose productions are of a varied nature, and who wish to obtain ideas for the development and improvement of their own costing methods.

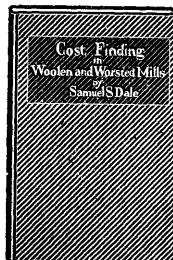

The system of cost finding described in this book is adapted to all kinds of woolen and worsted mills, large and small, also spinning mills and weaving mills carrying on all the operations from raw materials to finished cloth.

Published by *TEXTILES*, 79 Milk Street, Boston, Massachusetts

SEND FOR OUR BOOK CATALOG

## Everything In Latch Needles

No gauge is too small, none too large for Corey Latch Needles. They are made in the largest individually owned needle factory in America by men of long experience and great skill. Best in workmanship, perfect in design, of great strength and durability, they have a permanent smoothness which is characteristic of Corey Needles.

The Corey line is unrivalled. Quality and Corey are synonymous when applied to latch needles. Made in a model factory under perfect factory conditions by needle specialists, some of whom have devoted their lives to the making of needles.

Send for samples and prices.

## WILLIAM COREY COMPANY

CHAUNCEY A. WILLIAMS, Sole Owner

Manchester, N. H.

**WOOLEN AND WORSTED.**

The Philippi (W. Va.) Blanket Mills recently have installed twelve automatic looms. They have erected a warehouse adjoining the mill.

The Allen Woolen Mills, of Rochester, N. Y., will in the near future erect a one-story addition to their plant.

The Peerless Woolen Co. are planning to establish a woolen cloth mill at Chattanooga, Tenn.

The E. Richard Meinig Company, of Reading, Pa., have installed new equipment for manufacturing wool jersey, artificial silk jersey and pure silk jersey.

The Old Town (Me.) Woolen Company has commenced the erection of a one-story mill and office addition.

The Kelly-Hughes Co., Inc., manufacturer of waste, Philadelphia, Pa., are having plans prepared for the erection of an addition to their plant.

The Windsor Mfg. Co., manufacturers of worsted goods, Philadelphia, Pa., are planning to erect an addition to their plant.

The Greenwich Mills, of East Greenwich, R. I., manufacturers of worsteds, have had plans prepared for a four-story addition to their plant.

The Red Brooks Mills, Claremont, N. H., manufacturers of fancy cotton and worsted dress goods, are installing a set of cards and one mule to make their own yarns.

Charles W. House & Co., manufacturers of felt goods, etc., have begun the erection of a two-story addition to their local plant.

The Wearwell Sheeting Mill of the Carolina Cotton and Woolen Mill Company, of Draper, N. C., are adding 36 Draper pillow tubing looms and 14 jack spinning frames to their equipment, and are erecting 13 houses for employees.

The Milwaukee (Wis.) Wool Carding Mills are erecting a two-story building.

A mill building is now being erected for the Berkeley Woolen Co., Martinsburg, W. Va., in which will be installed 12 mules and 360 spindles.

Samuel Hird & Sons, Inc., manufacturers of worsteds, Garfield, N. J., have awarded a contract for the erection of a two-story warehouse.

**REMOVAL NOTICE.**

The Hellenic Chemical & Color Company has returned to their old building at No. 1 Cedar Street which has been remodelled throughout.

**Our Service  
To Textile Mills**

In connection with the use of



**Starches  
Gums  
Dextrines  
AND  
Specialties**

For sixty-nine years it has been our aim to supply our customers with material of the highest quality, and to render every possible service in connection with the application of our products.

**Our Service Department**

As a means of rendering a still greater service to our customers we have established a service department for the purpose of furnishing definite and accurate advice in connection with use and application of any of our products. This department is unusual and distinctive in that it is in charge of a well-known textile chemical expert, who has had a wide experience in the textile finishing field. This service is at your disposal.

**Chas. Morningstar & Co., Inc.**

349 Broadway, NEW YORK

BOSTON

CHICAGO



Our factory at Southbridge, which is the largest shuttle factory in the world

Established 1843

**LITCHFIELD SHUTTLE CO.**

SOUTHBRIDGE, MASS., U. S. A.

Manufacturers of

**SHUTTLES, SHUTTLE IRONS**

and

**HEDDLES**

**SHUTTLES FOR ALL KINDS OF LOOMS**

## EMPLOYMENT DEPARTMENT

WHERE EMPLOYERS AND EMPLOYEES MEET

### SITUATIONS WANTED

**Overseer of Weaving.** 2 years' experience. Draper looms. Age 36. Married. Address Box 239, TEXTILES, 79 Milk St., Boston, Mass.

**Overseer of Jacquard Weaving.** 10 years' experience. Table damask, towels and napkins. Age 31. Married. Address Box 246, TEXTILES, 79 Milk St., Boston, Mass.

**Weaving Overseer.** Eight years' experience. Gingham. Age 38. Married. Address Box 204, TEXTILES, 79 Milk St., Boston, Mass.

**Overseer of Spinning.** 20 years' experience. 3s to 30s yarns. Age 44. Married. Address Box 219, TEXTILES, 79 Milk St., Boston, Mass.

**Overseer of Spinning.** 15 years' experience. 30s hosiery, 40s weaving. Age 29. Married. Address Box 218, TEXTILES, 79 Milk St., Boston, Mass.

**Weaving Overseer.** 12 years' experience. All kinds of fancies and looms. Age 36. Married. Address Box 217, TEXTILES, 79 Milk St., Boston, Mass.

**Superintendent.** 8½ years' experience. Yarns, twines, rope drills, twills, sheeting and ducks. Age 33. Married. Address Box 216, TEXTILES, 79 Milk St., Boston, Mass.

**Hosiery Carder and Spinner.** 12 years' experience. Hosiery and hard yarns. Age 35. Married. Address Box 220, TEXTILES, 79 Milk St., Boston, Mass.

**Master mechanic.** 25 years' experience. Woolen, worsted and cotton. Age 45. Married. Address Box 301, TEXTILES, 79 Milk St., Boston, Mass.

**Overseer of Weaving.** 3 years' experience as second-hand and 2½ years' experience as overseer. Plain and fancy. Age 35. Married. Address Box 249 TEXTILES, 79 Milk St., Boston, Mass.

**Superintendent.** 15 years' experience. Brown sheeting 80x80 and print cloth. Age 49. Married. Address Box 251, TEXTILES, 79 Milk St., Boston, Mass.

**Superintendent or Boss Finisher.** 26 years' experience. Age 46. Married. Address Box 267, TEXTILES, 79 Milk St., Boston, Mass.

**Overseer of Weaving.** 7 years' experience. Drills and heavy sheetings. Age 42. Married. Address Box 242, TEXTILES, 79 Milk St., Boston, Mass.

**Weaving or Cloth Room overseer.** 28 years' experience. Sheeting and drills. Age 46. Married. Address Box 234, TEXTILES, 79 Milk St., Boston, Mass.

**Superintendent.** 12 years' experience as designer and overseer and 2 years' experience as superintendent. Fancy shirting and bed spreads. Age 39. Married. Address Box 257, TEXTILES, 79 Milk St., Boston, Mass.

**Cotton Mill Superintendent.** 14 years' experience. Twine and rope. Age 39. Married. Address Box 221, TEXTILES, 79 Milk St., Boston, Mass.

**Wool and Worsted Loom Fixer.** 28 years' experience. Woolen and Worsted. Address Box 222, TEXTILES, 79 Milk St., Boston, Mass.

**Cotton Mill Superintendent.** 5 years' experience. Sheetings, drills, duck and colored cotton goods. Age 38. Married. Address Box 223, TEXTILES, 79 Milk St., Boston, Mass.

**Overseer of Napping.** 15 years' experience. Age 34. Married. Address Box 224, TEXTILES, 79 Milk St., Boston, Mass.

**Overseer of Cloth Room.** 3 years' experience. Sheetings, Ducks, Osna-burgs. Age 28. Married. Address Box 226, TEXTILES, 79 Milk St., Boston, Mass.

**Overseer of Spinning.** Eight years' experience. Any class of goods. Age 29. Married. Address Box 206, TEXTILES, 79 Milk St., Boston, Mass.

**Cotton Carding or Spinning.** Twenty-five years' experience. Sheeting and gingham. Age 50. Married. Address Box 213, TEXTILES, 79 Milk St., Boston, Mass.

**Overseer of Spinning.** Ten years' experience. Between 10s and 60s. Age 27. Married. Address Box 215, TEXTILES, 79 Milk St., Boston, Mass.

**Carding or Spinning Overseer.** 15 years' experience. Plain, fancy, white and colored. Age 40. Married. Address Box 231, TEXTILES, 79 Milk St., Boston, Mass.

**Superintendent of Small Mill.** 20 years' experience. 4s to 30s single or ply. Age 42. Married. Address Box 259, TEXTILES, 79 Milk St., Boston, Mass.

**Overseer of Cotton Weaving.** 3 years' experience as second hand; 6 years' experience as overseer. Age 39. Married. Address Box 258, TEXTILES, 79 Milk St., Boston, Mass.

**Overseer of Carding and Spinning.** 12 years' experience. Age 38. Married. Address Box 263, TEXTILES, 79 Milk St., Boston, Mass.

**Superintendent or Boss Carder.** 12 years' experience. Sheetings and Yarns. Age 41. Single. Address Box 228, TEXTILES, 79 Milk St., Boston, Mass.

**Superintendent or Boss Weaver.** 16 years' experience. Age 41. Married. Address Box 229, TEXTILES, 79 Milk St., Boston, Mass.

**Fixer.** Wildman ribbers. Can furnish references. Now employed as overseer and fixer. 7 years' experience. Address Box 273, TEXTILES, 79 Milk St., Boston, Mass.

**Overseer of Weaving.** 20 years' experience. Box, plain and automatic looms. Good manager of help. Age 38. Address Box 308, TEXTILES, 79 Milk St., Boston, Mass.

# CLIFT & GOODRICH

328-330 Broadway

Established 1891

New York, U. S. A.

Sales Agent

## KNIT UNDERWEAR—SWEATER COATS

WE are exclusive selling agents for FIFTY-TWO MILLS producing all grades of underwear in all weights and in all fabrics for all climates in every part of the world.

Our lines consist of—

Flat and ribbed wool and flat and ribbed cotton underwear in shirts, drawers, vests, pants and union suits for men, women and children.

There is no requirement in popular priced underwear that we cannot supply to the wholesale and export trade.

Our line of popular priced Sweater Coats is also complete for all demands.

## KNIT UNDERWEAR—SWEATER COATS

Established 1870

Incorporated 1890

## The Warren Soap Manufacturing Company

77 Summer Street Boston, Mass.

### National Silk Dyeing Company

Main Office, Citizens' Trust Co. Building,  
Paterson, N. J.

New York Salesroom, 60 University Place.  
Telephone 1551 Stuyvesant

### SKEIN SILK DYEING

Of every description for all branches of  
textile manufacture

### Hosiery Dye A Specialty

WORKS:

Paterson, N. J.	Allentown, Pa.
Dundee Lake, N. J.	Williamsport, Pa.

### The White Tar Aniline Corporation

Headquarters	Works
56 Vesey St., New York	Kearney, N. J.

### BASIC ACID DIRECT and SULPHUR COLORS

Special shades matched  
We guarantee entire uniformity

### FOR GREATER PRODUCTION AND LOWER COST

USE THE

### PAYNE WINDER

Over 2,500 in Successful Operation in Pro-  
gressive Hosiery and Underwear Mills

### IMPROVED UPRIGHT SPOOLERS

To Spool from Cop, Skein or Bobbin. Doubling  
Spoolers for doubling 2, 3 or more ends into one.  
Upright Quillers, Quill from Cop, Skein or Bob-  
bin.

Ring Dresser, Spooler and Reel Spindles. Cop  
Skewers, Warp, Spool, Spooler Guides, Bolsters, and  
Stops Made and Repaired at Short Notice.

GEO. W. PAYNE CO. 102 BROAD STREET  
PAWTUCKET, R. I.

Established 1865—Incorporated 1903.

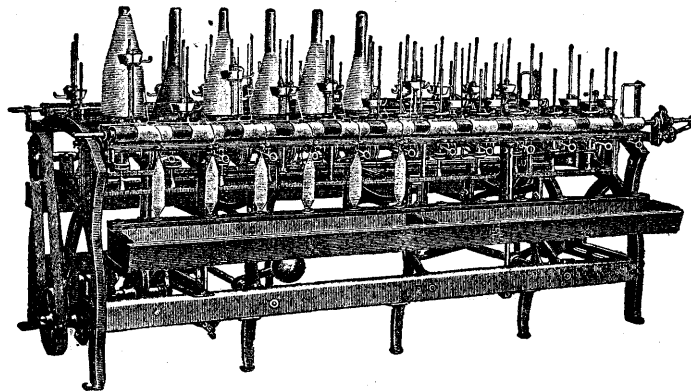

## DELAHUNTY DYEING MACHINE CO.

ESTABLISHED 1880

### Manufacturers of Textile and Mining Machinery

Revolving Cylinder Raw Stock Dyeing and Bleaching Machines  
 Revolving Cylinder Hosiery Dyeing and Bleaching Machines  
 Hosiery, Oxidizing, and Tom Tom Machines  
 Circulating Type Raw Stock Dyeing and Bleaching Machines  
 Circulating Type Beam Dyeing Machines for Dyeing  
 Cotton Warp on Beams, 1 to 12 Beams in One Operation

SPECIAL MACHINES FOR ANILINE, SULPHUR, INDIGO, AND OTHER VAT COLORS

OFFICE AND WORKS, PITSTON, PA., U. S. A.

## WILDT & CO., Limited,

The Boulevard, Leicester, England

### KNITTING MACHINE BUILDERS AND EXPORTERS

*Please write for catalogues*

We are also open to negotiate for the import of American Underwear Machinery for the European market.

## THE NEW BEDFORD TEXTILE SCHOOL

The New Bedford Textile School is now a cotton textile institute of the Commonwealth of Massachusetts. It is located in New Bedford, Mass., an attractive residential city situated on Buzzards Bay, and the largest producer of fine yarns and fancy woven fabrics in this country.

Diplomas are granted for completion of three years' study and practice in any one of the following courses: Cotton Manufacturing, Textile Designing, Carding and Spinning, Textile Chemistry (Dyeing and Finishing), Seamless Hosiery Knitting, and Latch Needle Underwear Knitting. Mechanical drawing, machine shop practice, steam, electrical and textile engineering given in connection with the above courses. Special shorter courses may be arranged for.

**Tuition free to residents of Massachusetts**

Illustrated catalogue supplied free on application.

WILLIAM E. HATCH, A.M., *President.*

## LOWELL TEXTILE SCHOOL

Four-year degree courses in

### CHEMISTRY AND TEXTILE COLORING — TEXTILE ENGINEERING

Degrees of B. T. C. (Bachelor of Textile Chemistry) and B. T. E. (Bachelor of Textile Engineering) offered for completion of prescribed four-year courses.

Three-year diploma courses in

### COTTON MANUFACTURING

### WOOL MANUFACTURING

### TEXTILE DESIGNING

Scientific and practical training in all processes of textile manufacture, including all commercial fibres.

Certified graduates of High Schools and Academies admitted without examination. For catalogue address

CHARLES H. EAMES, S. B., *President*, LOWELL, MASSACHUSETTS

## THE FRANKLIN MACHINE COMPANY

Providence, Rhode Island

OPERATING

FRANKLIN FOUNDRY & MACHINE SHOPS Telephone Union 963  
 HARRIS CORLISS ENGINE PLANT " " 1857

ENGINEERS

FOUNDERS

MACHINISTS

Manufacturers of Harris Corliss Engines—Brown Valve Gear applied to all makes of Corliss Engines, Reboring Cylinders, Overhauling and Repairs on all kinds of Engines and Machinery—Shafting, Pulleys, Bearings, Couplings, Hangers, etc. Silk Spinning Machinery, French Worsted Drawing Frames (Frotteurs), Iron Castings and General Mill Repairs, Ball Winding Machines, Shoe Lace Tipping Machines, Cotton Bat Heads, Yarn Dressers, Special Machinery for Textile Work.

## MILL NOTES.

The Spencer Mills of Rutherfordton, N. C., are building an addition to their plant in which they will install 2,000 new spindles.

The Griffin (Ga.) Manufacturing Co. have recently added to their equipment 200 Crompton & Knowles automatic looms.

The American Mills Co., manufacturers of webbing, New Haven, Ct., have begun the erection of a brick addition to their plant.

The Roy Woolen Co., of Watervliet, N. Y., are erecting an addition to their plant.

Contract has been awarded for the erection of a factory building for Collins & Aikman Co., manufacturers of plush goods, Philadelphia, Pa. A three-story building will be erected.

Folwell Bro. & Co., Inc., 3d & Cambria streets, Philadelphia, Pa., manufacturers of worsted goods are planning to erect a five-story factory building addition to their plant.

The Woonsocket (R. I.) Falls Mills have awarded a contract for the erection of a new one-story brick dyehouse addition to their plant on South Main street.



*Specializing in Silk Soaps  
 also High Grade Fulling and  
 Scouring Soaps*

## SAVES SOAP



SAMPLE FREE

The Electric Smelting  
 & Aluminum Co.

LOCKPORT, N. Y.



**KNITTING.**

The Lynchburg (Va.) Hosiery Mills are planning to erect an addition to their plant.

Geo. H. Tippett, formerly of Pelzer, S. C., has taken the position of overseer of weaving at the Arkwright Mills, Spartanburg, S. C.

Mr. J. H. Bagwell, formerly of Duke, N. C., has taken the position of superintendent at the Union Cotton Mills, Lafayette, Ga.

The Moorehead Knitting Company, of Harrisburg, Pa., are planning the erection of an addition to their plant.

The United Hosiery Mills, of Chattanooga, Tenn., are erecting an addition to their plant. They also have twenty-five cottages under construction.

Plans are being prepared for a group of buildings to be erected for the Rockland Hosiery Company, of Philadelphia, Pa.

The Hemshaw Hosiery Mills, of Oxford, N. C., will in the near future add to their equipment fifty knitting machines.

The Norristown (Pa.) Hosiery Company has purchased a building which was formerly used for a shirt factory. The concern will remodel it and install machinery for the manufacture of hosiery.

The Morris Ellis Company, Spring City, Pa., has purchased the entire equipment of the Commonwealth Knitting Mills. They will manufacture silk and mercerized hosiery.

The Zwicker Knitting Company, manufacturers of mittens, gloves and fancy knit goods, have leased a building in Appleton, Wis., in which they will install new machinery.

The Princeton Knitting Mills, of Richmond, Cal., plan extensive additions to their plant. They manufacture bathing suits, sweaters, athletic goods, toques, etc.

The Notaseme Hosiery Co., Philadelphia and Germantown, Pa., have awarded a contract for the erection of a new plant.

The Moorehead Knitting Co., of Harrisburg, Pa., are to build additions to their plant consisting of two buildings.

**SCREW MACHINE PRODUCTS**

for Textile Mills and allied industries. We make special shaped turnings in steel or brass. Send samples or blue prints for quotations. Please state quantities ordered.

SHAMOW SHUTTLE COMPANY,  
Woonsocket, R. I.

Work has already been started on construction of the new knitting mill to be built here by J. S. Frost and J. E. Black.

**PERSONALS.**

W. R. Hodge has been promoted to overseer of spinning of Mill No. 2, of the Fulton Bag & Cotton Mills, Atlanta, Ga.

Y. E. Yoss has accepted the position of superintendent of the Riverside Mill, No. 6, Danville, Va.

L. Walter has taken the position of overseer of spinning at the Hoskins Mills, Charlotte, N. C.

W. D. Thornbury, formerly employed at the Cannon Mills, Concord, N. C., has accepted the position of carder and spinner at the Edna Mills, Reidsville, N. C.

Charles S. Lydecker, of Philadelphia, Pa., has accepted the position of boss knitter for E. Richard Meinig Company, Reading, Pa.

Joseph Glotz, formerly of Woonsocket, R. I., has accepted the position of overseer of winding and twisting for the Stillwater Woolen Co., at Harrisville, R. I.

F. A. Meyers has been appointed superintendent of Reiling & Schoen, Inc., West Hoboken, N. J., Scranton, Pa., and Valley Falls.

Robert G. Kelso, formerly selling agent for the Montrose Worsted Co., Woonsocket, R. I., has accepted the position of resident buyer for Joseph & Feiss, clothing manufacturers, of New York City.

George Pethybridge, who comes from Fitchburg, Mass., has taken the position of overseer of dyeing for the Wakefield Manufacturing Co.

George D. Wooley has been promoted to superintendent of weaving at the Bristol Corporation.

**Proven  
Very Valuable**

"Your cost system has proven very valuable. It is simple, practical and efficient."—A Client.

A copy of "Where Profits Go in Textile Plants" will be mailed free upon request. Write for it today.

**RALPH E. LOPER**

FALL RIVER, MASS.

Textile Production Engineer  
Specialist in  
Textile Cost Methods



**FRED S. GILLEY**

is always pleased to receive inquiries from weaving and knitting mills.

**WOOLEN AND WORSTED YARNS  
and WORSTED TOPS**

179 SUMMER STREET — Close to South Terminal — BOSTON, MASS.

**FOR SALE**

- 1 36" Burr Picker—Curtiss & Marble Make.
- 1 36" Bromwell Feeder for use in connection with Burr picker mentioned above.
- 2 30" Burr Pickers—Curtiss & Marble Make.
- 1 110" American Blower Steel Plate Fan—Belt Driven.
- 1 Lot of Pulleys & Hangers.

All of the above are in good condition and we offer all or any part of the lot at very low prices.

**The American Pad & Textile Co.**

GREENFIELD, OHIO

**FOR SALE**

- 5 D. & F. 240 spindle mules 1 7/8" gauge, 9 1/2" above collar board, first-class condition.
- 2 J. & B. 300 spdle mules 1 7/8" gauge, 9" above collar board, good condition.
- 10 looms 92 to 117".
- 1 D. & F. 36" mixing picker, 4 feed rolls.
- 4—48" Bramwell feeds.
- 4—48" S. & F. metallic breasts.
- 1—5 bowl wool scouring machine.

JOHN J. HEALY, Newtonville, Mass.

**WANTED**

To buy 84 needle and 108 needle Model K Scott & Williams knitting machines. Also 220 needle and 240 needle 3 1/2" cylinder Scott and Williams and Banner half hose knitting machines. Please state full particulars as to condition of machines. Address Box 527, TEXTILES, 79 Milk St., Boston, Mass.

**J. K. LAMB TEXTILE MACHINERY CO.**

**SECOND-HAND  
TEXTILE MACHINERY**

For cotton, woolen and worsted  
246 Chestnut St. Philadelphia, Pa.

**WANTED**

Weavers and Spinners on  
Fancy Woolens

**CROWN MILLS**

Marcellus, New York

ESTABLISHED 1870  
INCORPORATED 1890

CODE ABC  
5TH EDITION

# CRANE

## SPRING AND LATCH NEEDLE KNITTING MACHINES

Will Enable Any User To Improve His Business

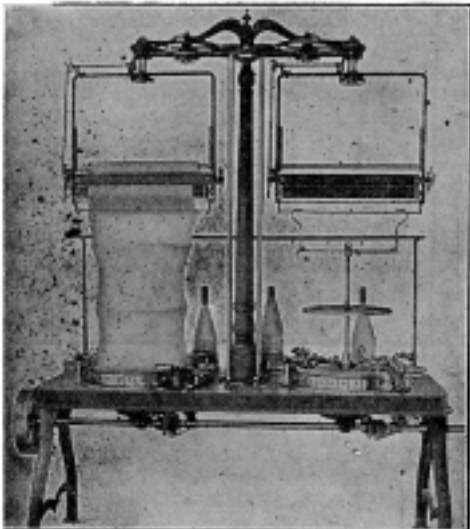

### Spring Needle Underwear Machine

A splendid machine for balbriggan underwear, stockingettes, eiderdowns and all kinds of fleeced fabrics.

Made in large variety of sizes with automatic take-up, etc.

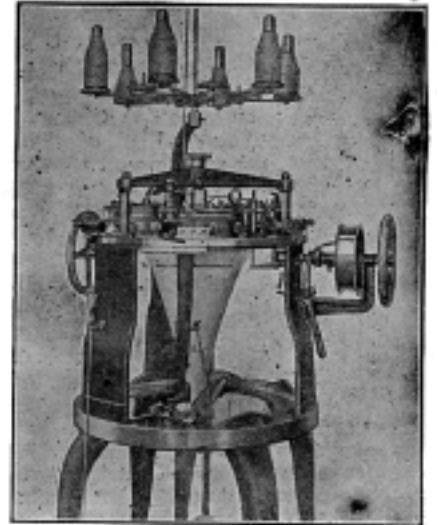

### New Spring Needle Rib Machine

Has new style feed, stop motion and take-up features.

Especially made to produce high grade ribbed underwear. Will make finest fabric on the market. An ideal machine with all parts handy to get at.

Improved Spring Needle Underwear Machine

New Spring Needle Rib Machine

Our late models challenge comparison. Write for further information.

**CRANE MANUFACTURING CO. : LAKEPORT, N. H.**

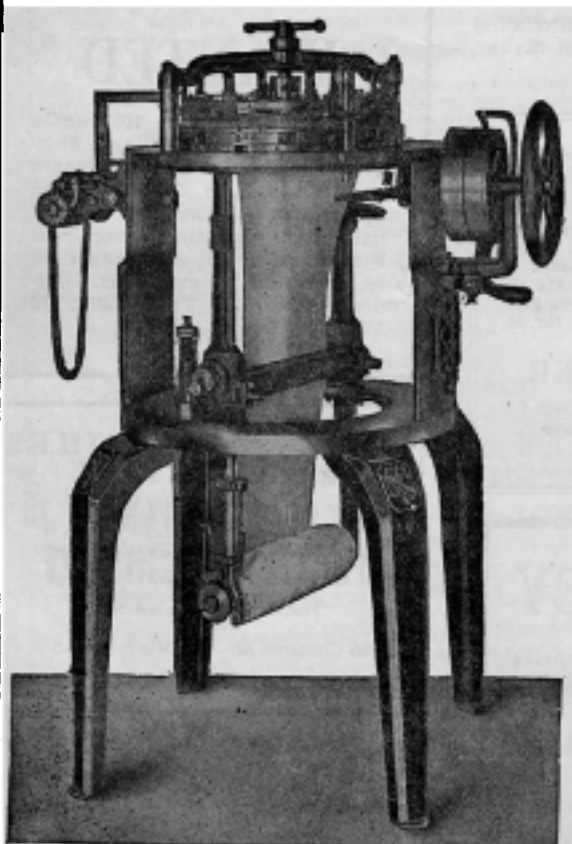

## Circular Rib Knitting Machinery

For making Ribbed Underwear, Combination Suits, Cuffs, Shirt Borders, Ribbed Hosiery, Fancy Knit Goods, Etc.

CORRECT Construction, Excellence and Durability—Quality of Fabric and Production Unexcelled—Latest Improvements.

**NYE & TREDICK COMPANY**

718-720 Cherry Street

PHILADELPHIA - - - PA.

**NEW DYES.**

(Continued from page 34)

Sulphur Brown 3 R is similar in shade and properties to the pre-war color, Katigene Red Brown. It possesses a good fastness to light, washing and organic acid. In shade it is reddish brown and can be after-treated with chrome, blue-stone and acetic acid. The after-treated shade is bluer and duller than the self shade. Because of its fastness to acid cross dyeing, this color is suitable for the dyeing of warps for such classes of material as pushes and union goods.

**RECENTLY BROUGHT OUT.**

**Thread Drawing Machine.** Jno. W. Eshelman, Jr. A machine for drawing threads from sheetings, damasks, linens and other fabrics used for hemstitched sheets, pillow slips, table cloths, etc.

**Scroll Guard for Mules.** George Crabtree, Quarry Street Works, Stalybridge, Eng. An improved scroll guard for mules to meet the requirements of the agreement of 1912 between cotton mill employers, operatives and inspectors.

**Washing Machine Stop Motion.** Wood & France, 55 Vickerman's Bldg., Thongsbridge, near Huddersfield, Eng. A stop motion for stopping a piece goods washing or scouring machine when the piece fails to pass through the guide-eye, or if the cloth winds around the roller.

**Yarn Tension Device.** Mellish, Richardson & Co., Ltd., Stonebridge Mills, Wortley, Leeds, Eng. A spring-pressed disc tension having a revolving bushing on the spindle to

prevent the thread from cutting the spindle that supports the discs. The device is the invention of R. W. Taylor, who is employed by the firm.

**EXPOSITION OF CHEMICAL INDUSTRIES.**

In the course of an address on dyestuffs at the Exposition of Chemical Industries at Chicago, Sept. 23, J. Merritt Matthews, editor of the Color Trade Journal, urged legislation which would suitably protect the American dyestuff industry. "It is a proven fact," said Mr. Matthews, "that the American dyes are fully as good as the dyes imported from Europe prior to the war, and within a short time every pre-war dye will have been reproduced in this country. There are now 77 firms in 16 states making dyes and dye products. They have invested many millions of dollars and should be protected. The insidious propaganda of the old dye interests in the United States must be stopped. A bill has been introduced in Congress by Congressman Nicholas Longworth which through a protective tariff and a licensing commission would protect the industry from unfair foreign propaganda. Everything possible should be done to push this measure.

"In 1918 American manufacturers made 53,000,000 pounds of dyes and dye materials or nearly as much as the annual consumption prior to the war."

The exposition was largely attended. There were 350 exhibitors. The dye exhibit was very fine, far surpassing exhibits of former years. Among the many exhibitors of interest to the textile trade were the Carrier Engineering Corporation, Aniline Dyes and Chemicals, Inc., the Electro Bleaching Gas Co., National Aniline and Chemical Co., Inc., the Parks-Cramer Co., Newport Chemical Works, Inc., Frank Hemingway, Inc., General Electric Company, Philadelphia Drying Machine Co., C. J. Tagliabue Mfg. Co., the Roessler & Hasslacher Chemical Co., and others.

Next year's exposition is to be held in New York.

**PERSONALS.**

J. A. Sorrell, formerly overseer of carding at the Pacolet Mills, Gainesville, Ga., has accepted the position of superintendent of the Gainesville (Ga.) Cotton Mills.

W. E. Baggett, of Columbus, Ga., has taken the position of overseer of carding at the Adams Mills, Macon, Ga.

E. W. Spencer, formerly employed at the Limerick (Me.) Mills, as accepted the position of superintendent of the yarn department of the Stillwater Worsted Co., Harrisville, R. I.

Vincent Degnan has taken the position of overseer of dyeing for the Essex Mills, American Felt Co., Picton, N. J.

Fred McGuire has accepted the position of overseer of carding for the Indian Spinning Mills, South Natick, Mass.

James B. Grady has been appointed overseer of carding for the Pitman Manufacturing Co., Laconia, N. H.

H. S. Sykes has been engaged as superintendent of the Blackstone Woolen Co., Mills, Chepachet, R. I.

Arthur J. Draper, formerly of the American Cotton Manufacturing Association, has been appointed on the State Reconstruction Board.

Jessie Wolf, formerly of Whitney, S. C., has taken the position of overseer of weaving at mills 1 and 2 of the Clinchfield Mfg. Co., Marion, N. C.

C. A. Mitchell, of Spartanburg, S. C., has been elected overseer of weaving with the Royal Bag Mills, Charleston, S. C.

R. F. Gardner, formerly of Lincoln, N. C., has accepted the position of overseer of spinning at Long Shoals (N. C.) Cotton Mills.

D. B. MaHaffey, formerly overseer of spinning at the Eureka Mills, Chester, S. C., has taken the position of carding and spinning at the Bellecue Mills, Hillsboro, N. C.

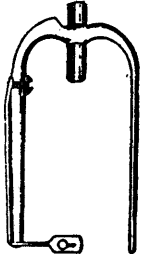

**FOR SALE—All Size Flyers, Practically as Good as New, Polished Inside and Out at Bargain Prices.**

**Southern Spindle and Flyer Co., Inc.**  
CHARLOTTE, N. C.

Manufacturers, Overhauled and Repairers of Cotton Mill Machinery

W. H. Monty, Pres. & Treas.      W. H. Hutchins, V.-Pres. & Sec'y

**TURBINE WATER WHEELS OF GUARANTEED EFFICIENCY**



**CYLINDER GATE, WICKET GATE, REGISTER GATE TURBINES, VERTICAL AND HORIZONTAL; SINGLE OR IN PAIRS.**

**ALSO, IMPULSE WATER WHEELS.**

**FOR PRICES AND CATALOGUES, Address**

**DAVIS FOUNDRY & MACHINE WORKS**  
ROME, GEORGIA

**LOMBARD**  
**Foundry, Machine, Boiler Works and Mill Supply House**

**AUGUSTA, : : GEORGIA**

Capacity, 300 Hands  
Hundred Thousand Feet Floor Space

Cotton, Oil, Gln, Saw, Grist, Fertilizer, Cane, Shingle Mill Machinery Supplies and Repairs and Castings, Shafting, Pulleys, Hangers, Wood, Coal and Sawdust Grate Bars, Pumps, Pipe, Valves and Fittings, Injectors, Belt- ing, Packing Hoses, etc. Cast every day. One hundred machines and good men ready to do your work quick.

**E. L. & Fred Sheridan**  
**CONTRACTORS**  
**Overhauling, Spinning, Twisting and Fly Frames**  
**WINDER, GEORGIA**

The Avandale Mills of Birmingham, Ala., have awarded a contract for a brick addition to their branch plant at Alexander City.

# TEXTILES

## COTTON CLOTHS.

(Reported by Louis Lowinson, cotton goods broker, 72 Leonard Street, New York.)

80/80 39" 4.00 plain cloths	26
72/76 39 4.25 "	22
68/72 39 4.75 "	20½
64/64 38½ 5.15 "	17½
64/60 38½ 5.35 "	17
64/56 38½ 5.50 "	16¼
60/52 38½ 6.00 "	15
60/48 38½ 6.25 "	14½
64/60 27 7.60 "	11
48/48 37" 4.00 Sheetings	16½
56/60 36 4.00 "	19
48/40 36 5.50 "	13
48/48 40 2.85 "	23
30" 3.25 Drills	22
30 3.00 "	23
37 3.50 "	20
37 3.95 "	18
88/80 40" 8.50 plain comb	28
76/82 40 9.00 "	22
96/92 40 7.50 "	32
64/112 39 4.00 sateens	30
64/104 39 4.20 "	28

## RAW COTTON

Middling, Sept. 25..... 31.80

## COTTON YARNS

### EASTERN

#### COMBED PEELER

10s	78
16s	79
20s	84-86
30s	1.00-1.03
40s	1.15

#### CARDER PEELER

10s	61
16s	62
20s	63
26s	65
30s	67-70
40s	90-95

#### MERCERIZED

2/40s	1.05-1.08
2/50s	1.20-1.40
2/60s	1.28-1.30
2/70s	1.50-1.52

#### SOUTHERN

#### HOSIERY FRAME

10s	52
14s	55

20s	61
24s	61-65
30s	72
2/20s	41-43
2/10s	45-46

### WARPS

2/10s	58-60
2/20s	65-67
2/24s	75-77
2/30s	85

## DOMESTIC WOOL

### Ohio and Pennsylvania Fleeces

Delaine washed	88-90
Fine unmerchantable delaine	86-87
XX	71-72
Delaine unwashed	82-86
Fine unwashed	68-70
½ blood combing	80-81
¾ blood combing	70
¼ blood combing	67-68
½, ¾, ¼, blood combing	60-61
Common and braid	45-47

### Southern Fleeces

Lake mediums	60-62
Georgia mediums	62-64
Virginia, Kentucky and Similar	
½ blood unwashed	81-82
¾ blood unwashed	72-73
¼ blood unwashed	70
Common and braid	45-46

### SCOUED BASIS

#### Texas

Fine 12 months	1.60-1.70
Fine 8 months	1.38-1.40
Fine fall	1.15-1.20

#### California

Northern	1.60-1.65
Middle County	1.40-1.50
Southern	1.30 1.35
Fall free	1.10-1.15
Fall defective	1.00-1.05

#### Oregon

Eastern No. 1 staple	1.80-1.85
Eastern clothing	1.50-1.55
Valley No. 1	1.65-1.70
Valley No. 2	1.30
Valley No. 3	1.05-1.15

#### Territory

Fine staple	1.85-1.90
½ blood combing	1.75-1.80
¾ blood combing	1.30-1.35
¼ blood combing	1.10-1.15
Common and braid	70-75
Fine clothing	1.50-1.60
Fine medium clothing	1.40-1.50

### Pulled

AA	1.65-1.70
Extra	1.75-1.80
A supers	1.55-1.60
B supers	1.15-1.25
C supers	85-95
Fine Combing	1.40-1.45
Medium combing	1.30-1.35
Coarse combing	1.00-1.05
California, finest	1.35-1.40
California, second	1.10-1.15

## FOREIGN WOOL

### SCOUED BASIS

#### Australian

Classes I and II	
Sydney 80s clothing	2.30-2.40
Sydney 70s average	2.25-2.30
Sydney 64s average	2.00-2.10
Geelong 74s	2.30-2.40
Geelong 64s	2.10-2.20
Geelong 60s	1.95-2.00

### SCOUED BASIS

#### Cape

12 months	1.60-1.70
Short combing	1.40-1.50
Clothing	1.25-1.30

### SCOUED BASIS

#### \*New Zealand

Crossbreds	
36s to 40s	73-75
40s to 44s	82-83
46s	90-95
46s to 48s	95-98
50s	1.00-1.10
56s	1.25-1.30
58s	1.70-1.75

## WORSTED YARNS

### BRADFORD SPUN

2/20s ¼ blood	2.20
2/30s ¼ blood	2.10
2/32s ¾ blood	2.25-2.45
2/36s ¾ blood	2.90-3.15
2/40s ½ blood	3.85-4.00

### FRENCH SPUN

1/20s ¼ blood	2.05-2.15
1/20s ¾ blood	2.25-2.30
1/30s ¾ blood	3.30-3.50
1/30s ½ blood	3.30-3.50

J. R. Tolar J. R. Tolar, Jr.  
J. H. Hart P. G. Hart

## TOLAR & HART

Cotton Yarn and Cotton  
Members of New York Cotton Exchange  
322 Chestnut Street, PHILADELPHIA, PA.  
49 Leonard Street, NEW YORK.

## WILLIAM WHITMAN CO., INC.

### YARNS

A wide and complete range suitable for all requirements

Boston New York Phila. Chicago

## J. B. Jamieson

77 Summer St., Boston  
COTTON YARNS

of all descriptions  
Correspondence Solicited

## United States Conditioning & Testing Co.

340 Hudson Street 220 Elkton Street  
New York, N. Y. Paterson, N. J.  
Cotton, Wool and Silk Conditioning,  
Fabric Testing and Chemical Analysis

### A Tape Belt for Universal Winders

We have perfected a cotton tape belt for driving Universal Winders. Also one for Camless Winders. We urge all users of these machines to write us for samples. We offer this with our full indorsement because exhaustive tests have satisfied us of its real merit.

BARBER MFG. CO

Spinning Tape Specialists,  
LOWELL, MASS.

## DANA WARP MILLS

Westbrook, Me.  
Cotton Yarns and Warps  
WHITE and COLORED

## HOSIERY BOARDS

QUALITY AND SERVICE

JOS. T. PEARSON  
1825E. Boston Ave., Philadelphia, Pa.

## RIVERS & LEWIS

Contractors and Dealers in  
Cotton Waste, Cotton Cloth, Cotton Yarns

Cheese Cloth Remnants  
New Mill Ends

113 Borden St., FALL RIVER, MASS.

## Fred Sternberg & Co.

530 BROADWAY, NEW YORK

MERCERIZED } COTTON YARNS  
GASSED }  
HARNES TWINES

## HUGHES FAWCETT

115 and 117 Franklin St., New York  
Linen Weaving and Knitting Yarns  
Linen Jacquard Harness Twines  
And Linen Yarns and Threads for  
Every Purpose

### Turkey Red Yarns

Large Stock Prompt Deliveries

1/50s-64s	.....	Nominal
2/40s 1/2 blood	.....	3.85-4.00
2/50s 1/2 blood	.....	4.25-4.50
2/70s Australian	.....	Nominal
FRENCH SPUN MERINO		
2/40s 1/2 blood	.....	3.10-3.15
1/40-50-50	.....	1.90-2.00
1/40-70-30	.....	2.20-2.40
1/40-80-20	.....	2.35-2.45

**OLD WOOLEN RAGS**  
**GOVERNMENT MAXIMUM**

Merinos		
Fine		35-36
Coarse light	19 1/2-	20
Fine dark		20-21
Coarse dark		14-14 1/2
Fine black		18-19
Serges		
Light		28-30
Brown		28-30
Blue		27-27 1/2
Black		23-24
Red		25-26
Green		32-33
Flannels		
White (Fine)		55-60
Red		37-38
Blue		38-40
Knit		
White		48-49
Blue		23-24
Black trimmed		33-34
Red		24-25
Brown		30-32
Light gray		17-18
Light hoods		35-36
Mixed hoods		18-19
Silver gray		31-32
Skirted worsteds		
Light	19 1/2-	20
Black		25-26
Blue		8- 8 1/2
Dark	16-16 1/2	
Brown	18 1/2-	19
Skirted cloth		
Fine light		14-16
Light		10-11 1/2
Blue		8- 8 1/2
Dark		6 1/2-7
Plain black		7 1/2-8
Skirted, tan cloth		24-25

The Fulton Bag & Cotton Mills of Atlanta, Ga., are planning to erect a mill which will have 50,000 spindles. The Irene Mills of Gaffney, S. C., manufacturers of table damasks, napkins, jacquard towels, will, in the near future, erect an addition to their plant, which will be used as a weave room. The Prendergast (Tenn.) Cotton Mills are planning to double the capacity of their plant, which will make an equipment of over 20,000 ring spindles and 10,000 twisting spindles. The Grace Cotton Mills Co., of Rutherfordton, N. C., will in the near future erect a building 300x125 feet. The Valley Falls Co., of Lincoln, R. I., will in the near future erect a large brick addition to their plant.

**B. COHEN & SONS**

LARGEST GRADERS OF

**New Woolen and Cotton Clippings**

AND ALL KINDS OF REMNANTS

*Write Us for Prices Before Shipping*

OFFICE AND WAREHOUSES

Office 1244-46 So. Union Avenue }  
Old Rag Department, 1511 So. Sangamon St. } **CHICAGO, ILL.**  
New Cotton Department, 757-759 W. Taylor St. }

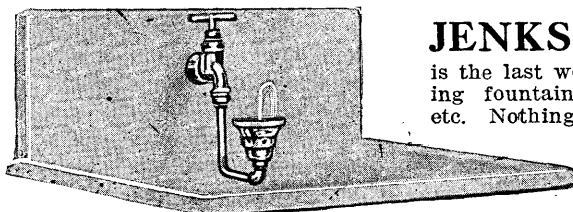

**THE JENKS BUBBLER**

is the last word in sanitary drinking fountains for mills, schools, etc. Nothing to get out of order.

Flow of water regulated as you wish. Reasonable in price. Will give absolute satisfaction and last

many years. If your plumber hasn't it in stock write us.

**H. F. JENKS COMPANY, Pawtucket, R. I.**  
Established 1870 Incorporated 1911

**ALL STEEL**

**ECONOMY**

**BALING PRESSES**

ALL SIZES FOR ALL PURPOSES  
LARGEST LINE BUILT IN U.S.A.

ECONOMY BALER CO., DEPT.  ANN ARBOR, MICH., U.S.A.

**JENNISON CO. PIPERS FITCHBURG, MASS.**

**Do You Want a Silent Partner?**

One who gives advice but does not talk back.

He is the "Daily News Record!"

The Daily Newspaper of the Textile Trade  
8 East 13th Street, New York

**FILL OUT AND RETURN**

Please let me know how the DAILY NEWS RECORD can be made to work for me.

Name .....

Business .....

Address .....

**THE BRADLEY STENCIL MACHINE**

Makes stencils in half a minute at reduced cost of 1-10 cent each

*Write for prices and samples*

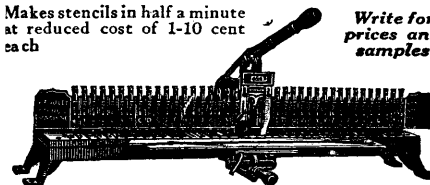

In Universal use by thousands of manufacturers and shippers  
Manufacturers of Oil Stencil Board

**A. J. BRADLEY, GEN. SALES AGENT**

101 Beekman Street New York City, N. Y.

**It Pays to Advertise in "Textiles" Because Progressive Mill Men Everywhere Are Its Readers.**

**WATER**

**WE-FU-GO AND SCAIFE**

**PURIFICATION SYSTEMS  
SOFTENING & FILTRATION  
FOR BOILER FEED AND  
ALL INDUSTRIAL USES**

**WM. B. SCAIFE & SONS CO. PITTSBURGH, PA.**

# CLASSIFIED INDEX TO ADVERTISERS

## Accountants and Engineers

Osoley & Marvin Co., Boston  
Ralph E. Loper, Fall River,  
Mass.

## Air Moistening

Carrier Engineering Corpora-  
tion, New York.  
Parks-Cramer Co., Fitchburg,  
Mass.

## Albion

Roessler & Hasslacher Chem-  
ical Co., New York.

## Asbestos Machinery

Smith & Furbush Machine Co.,  
Philadelphia, Pa.

## Automatic Feeds

(For cotton and wool)  
Smith & Furbush Machine Co.,  
Philadelphia, Pa.  
Philadelphia Drying Machinery  
Co., Philadelphia, Pa.

## Baling Presses

Economy Baler Co., Ann Arbor,  
Mich.  
Philadelphia Drying Machinery  
Co., Philadelphia, Pa.  
Smith & Furbush Machine Co.,  
Philadelphia, Pa.

## Ball Winding Machinery

Franklin Machinery Co., Prov-  
idence, R. I.

## Bleaching Kiers

Worcester Steam Boiler Works,  
Worcester, Mass.  
Philadelphia Drying Machinery  
Co., Philadelphia, Pa.

## Bleaching Machinery

Delahunty Dyeing Machine Co.,  
Pittston, Pa.

## Bleaching Materials

Roessler & Hasslacher Chem-  
ical Co., New York.

## Bleaching Oil

Jacques Wolf & Co., Passaic,  
N. J.

## Blowers and Blower Systems

Philadelphia Drying Machinery  
Co., Philadelphia, Pa.

## Bollers

Worcester Steam Boiler Works,  
Worcester, Mass.

## Boiler Feed Purifiers

Scaife & Sons Co., Wm. B.,  
Pittsburgh, Pa.

## Boxes and Box Sheeks

Jos. T. Pearson, Philadelphia.

## Braiding Machinery

Textile Machine Works, Read-  
ing, Pa.

## Bubblers (for sinks)

H. F. Jenks Co., Pawtucket,  
R. I.

## Carbonizing Machinery

Philadelphia Drying Machinery  
Co., Philadelphia, Pa.

## Chairs (for Mill Use)

H. F. Jenks Co., Pawtucket,  
R. I.

## Chrome Colors

Jacques Wolf & Co., Passaic,  
N. J.

## Clipping Machines (shoe lace)

Franklin Machine Co., Prov-  
idence, R. I.

## Cloth Cutting Machines

Eastman Machine Co., Buffalo  
Universal Cutter Co., St. Louis.

## Cloth Testers

Scott, H. L. & Co., Providence,  
R. I.

## Cloth Washers

Hunter, James, Machine Co.,  
No. Adams, Mass.  
Philadelphia Drying Machinery  
Co., Philadelphia, Pa.

## Cones, Paper

Pairpont Corp., New Bedford,  
Mass.

## Card Grinders

B. S. Roy & Son Co., Worces-  
ter, Mass.

## Cop Skewers

Shambow Shuttle Co., Woon-  
socket, R. I.

## Cotton Bat Heads

Franklin Machine Co., Prov-  
idence, R. I.

## Cotton Machinery

Philadelphia Drying Machinery  
Co., Philadelphia.  
Smith & Furbush Machine Co.,  
Philadelphia.  
Wildman Manufacturing Co.,  
Norristown, Pa.

## Cotton Yarn Bleachers

Home Bleach & Dye Works,  
Pawtucket, R. I.

## Cutting Machines

Eastman Machine Co., Buffalo.  
Universal Cutter Co., St. Louis.  
Wildman Mfg. Co., Norrist-  
town, Pa.

## Drawing Frames (French Wors- ted)

Franklin Machine Co., Prov-  
idence, R. I.

## Drinking Fountains

H. F. Jenks Co., Pawtucket,  
R. I.

## Drying Machinery

Philadelphia Drying Machinery  
Co., Philadelphia.

## Dusters

Smith & Furbush Machine Co.,  
Philadelphia.

## Dyers, Bleachers and Finishers

Home Bleach and Dye Works,  
Pawtucket, R. I.  
National Silk Dyeing Co., Pat-  
terson, N. J.  
Providence Dye Works, Prov-  
idence, R. I.

## Dyeing, Drying, Bleaching and Finishing Machinery

Delahunty Dyeing Machine Co.,  
Pittston, Pa.  
Philadelphia Drying Machinery  
Co., Philadelphia.

## Dyestuffs and Chemicals

Atlantic Dyestuff Co., Boston  
S. R. David & Co., Inc., Bos-  
ton, Mass.

Du Pont de Nemours & Co.,  
Wilmington, Del.  
Dye Exchange Corp. New  
York

Hellenic Chemical & Color Co.,  
New York City.

Kilpstein & Co., A., New York.  
Metz & Co., H. A., New York.  
Hemingway, Inc., Frank, New  
York.

Kohnstamm & Co., K., New  
York.  
Levinstein, I., & Co., Inc.,  
Boston.

National Aniline & Chemical  
Co., New York.  
Newport Chemical Works, Pas-  
saic, N. J.

White Tar Aniline Corpora-  
tion, New York.  
Jacques Wolf & Co., Passaic,  
N. J.

## Dyeing Temperature Regulators

Tagliabue Mfg. Co., C. J.,  
Brooklyn, N. Y.

## Electrical Constructors

General Electric Co., Schene-  
cady, N. Y.

## Electric Lamps

General Electric Co., Schene-  
cady, N. Y.  
Trop Specialties Co., New  
York.

## Electric Motors

General Electric Co., Schene-  
cady, New York.

## Engines

Franklin Machine Co., Prov-  
idence, R. I.

## Export Publicity

Salades Export Publishing Co.,  
New York City.

## Extractors, Logwood

Tolhurst Machine Works,  
Troy, N. Y.  
Worcester Steam Boiler  
Works, Worcester, Mass.

## Feed Water Purifiers

Scaife & Sons Co., Wm. B.,  
Pittsburgh, Pa.

## Flooring

Philadelphia Mineral Flooring  
Co., Philadelphia, Pa.

## Flyers

Southern Spindle & Flyer Co.,  
Inc., Charlotte, N. C.

## Fly Frames

Sheridan, E. L. & Fred, Win-  
der, Ga.

## Flyer Pressers

Southern Spindle & Flyer Co.,  
Inc., Charlotte, N. C.

## Felt Machinery

Smith & Furbush Machine Co.,  
Philadelphia.

## Filters (Water)

Norwood Engineering Co.  
Scaife & Sons Co., Wm. B.,  
Pittsburgh, Pa.

## Grinding Machinery

Roy & Son Co., B. S.

## Gums

Klipstein, A. & Co., New York.  
Chas. Morningstar & Co., New  
York.  
Jacques Wolf & Co., Passaic,  
N. J.

## Heddles

Litchfield Shuttle Co., South-  
bridge, Mass.

## Hosiery Boards

Pearson, J. T., Philadelphia.  
Philadelphia Drying Machinery  
Co., Philadelphia.

## Hosiery Machines

Brinton, H., Co., Philadelphia.  
Crane Manufacturing Co.,  
Lakeport, N. H.  
Nye & Tredick, Philadelphia.  
Textile Machine Works, Read-  
ing, Pa.

Wildman Manufacturing Co.,  
Norristown, Pa.

## Humidifying Apparatus

Carrier Engineering Corp., New  
York.  
Parks-Cramer Co., Fitchburg,  
Mass.

## Hydro-Extractors

Tolhurst Machine Works, Troy,  
N. Y.

## Hydrometers

Tagliabue Mfg. Co., C. J.,  
Brooklyn, N. Y.

## Iron Castings

Franklin Machine Co., Prov-  
idence, R. I.

## Knitting Machinery

Brinton, H., Co., Philadelphia.  
Crane Manufacturing Co.,  
Lakeport, N. H.  
Huse & Sons, W. D., Laconia,  
N. H.  
Hemphill Co., Pawtucket, R. I.  
Nye & Tredick, Philadelphia.  
Stafford & Holt, Little Falls,  
N. Y.

Textile Machine Works, Read-  
ing, Pa.  
Tompkins Bros. Co., Syracuse,  
N. Y.

Wildman Manufacturing Co.,  
Norristown, Pa.  
Wildt & Co., Leicester, Eng.

## Knitting Machinery, Full Fas- hioned

Textile Machine Works, Read-  
ing, Pa.

## Knitting Needles, Etc.

Brinton, H., Co., Philadelphia.  
Corey, William, Co., Manches-  
ter, N. H.  
Laconia Needle Co., Laconia,  
N. H.  
M. M. McCormick & Co., Phil-  
adelphia.

## Mercerizing

Home Bleach & Dye Works,  
Pawtucket, R. I.

## Manufacturers' Agents

Levey & Blankfield, New York.

## Mill Supplies

Lombard Foundry & Mill Sup-  
ply House, Augusta, Ga.

## Mordants

Jacques Wolf & Co., Passaic,  
N. J.

## Oiling Machinery

Park Co., G. M., The, Fitch-  
burg, Mass.

## Oils

Borne, Scrymser Co., New York  
Bradford Oil Co., Lynn, Mass.  
Swan & Finch Co., New York.

## Overhaulers

Southern Spindle & Flyer Co.,  
Inc., Charlotte, N. Y.

## Paints

Coolidge & Sons, Inc., F. J.,  
Augusta, Ga.

## Paper Cones and Tubes

Pairpont Corporation, New  
Bedford, Mass.

## Peroxides

Roessler & Hasslacher Chem-  
ical Co., New York.

## Pickers, Rag or Shoddy

Smith & Furbush Machine Co.,  
Philadelphia.

## Pipers

Jennison Co., Fitchburg, Mass.

## Pulleys

Franklin Machine Co., Prov-  
idence, R. I.

## Recording Gauges

Tagliabue Mfg. Co., C. J.,  
Brooklyn, N. Y.

## Recording Thermometers

Tagliabue Mfg. Co., C. J.,  
Brooklyn, N. Y.

## Regulators for Temperature

Tagliabue Mfg. Co., C. J.,  
Brooklyn, N. Y.

## Woolen Rags

Cohen & Sons, B., Chicago, Ill.

## Rings, Spinning and Twister

Southern Spindle & Flyer Co.,  
Inc., Charlotte, N. C.

## Rolls

Southern Spindle & Flyer Co.,  
Inc., Charlotte, N. C.

## Schools

Lowell Textile School, Lowell,  
Mass.  
New Bedford Textile School,  
New Bedford, Mass.

## Second Hand Textile Machinery

John J. Healy, Newtonville  
Mass.  
Lamb, J. K., Textile Machinery  
Co., Philadelphia.  
Edward Jefferson, Philadelphia

## Shuttle Irons

Litchfield Shuttle Co., South-  
bridge, Mass.

## Shuttles

Litchfield Shuttle Co., South-  
bridge, Mass.  
Shambow Shuttle Co., Woon-  
socket, R. I.

(Continued on following page)

## When Planning to Increase Production—

Ask an Eastman Representative to give you the benefit of his experience.  
He is familiar with the problems of cutting fabrics in quantities.

## EASTMAN GOLD MEDAL CUTTERS

May result in reducing your cutting costs — ask him.

### EASTMAN MACHINE CO., OF BUFFALO, U. S. A.

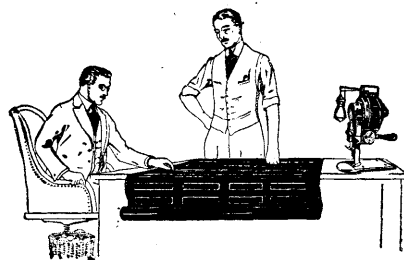

"It's Best to Buy the Best First"

NEW YORK 816 Broadway	PHILADELPHIA Heed Building, 1213 Filbert Street	ST. LOUIS 1420 Olive Street
BOSTON 87 Summer Street	DETROIT 119 E. Jefferson Avenue	SAN FRANCISCO 444 Market Street
CLEVELAND 1234 Superior Avenue, N. E.	CHICAGO 815 W. Van Buren Street	BALTIMORE 417 W. Baltimore Street
NEW ORLEANS, Godchaux Bldg.	HAMILTON, ONTARIO, 5 Sun Life Bldg.	

## CIRCULAR SPRING and LATCH NEEDLE KNITTING MACHINERY

For the Manufacture of

Flat Wool and Cotton Under- wear	Astrakhans
Balbriggan	Fur Cloths
Silk Skirts	Skirts and Toques with three color stripes
Fleece-Lined Fabrics	Sweaters with rack stitch, stripes and selvage edge
Jersey Cloth	

**TOMPKINS BROS. CO.,** 583 South Clinton St.  
ESTABLISHED 1846 SYRACUSE, N. Y.

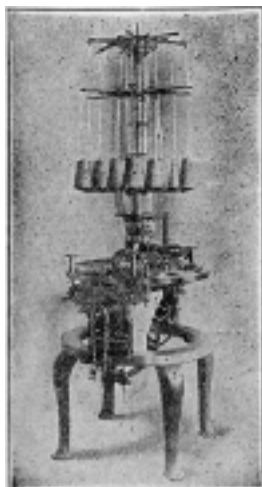

Sweater Machine

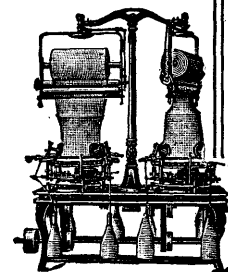

Spring Needle Machine

## CLASSIFIED INDEX TO ADVERTISERS—(Continued from page 46)

**Silk Noils**  
Fawcett, Hughes, New York.

**Silks (Raw)**  
General Silk Importing Co., New York.

**Selling Agents for Mills**  
Clift & Goodrich, New York.

**Singeing Machines**  
Philadelphia Drying Machinery Co., Philadelphia.

**Soaps**  
Electric Smelting and Aluminum Co., Lockport, N. Y.  
Original Bradford Soap Works, Providence, R. I.  
Warren Soap Mfg. Co., The, Boston, Mass.

**Special Textile Machinery**  
Franklin Machinery Co., Providence, R. I.

**Spindles**  
Southern Spindle & Flyer Co., Inc., Charlotte, N. C.

**Spun Silk Machinery**  
Franklin Machine Co., Providence, R. I.

**Starch**  
Chas. Morningstar & Co., New York.

**Stencil Machines**  
Bradley, A. J., New York.

**Steels (for mill use)**  
Jenks Co., H. F., Pawtucket, R. I.

**Tape Drives**  
Barber Mfg. Co., Lowell, Mass.

**Temperature Regulators**  
Carrier Engineering Corporation, New York.

**Tagliabue Mfg. Co., C. J.,** Brooklyn, N. Y.

**Testing Establishments**  
U. S. Conditioning & Testing Co., New York.

**Thermometers**  
Tagliabue Mfg. Co., C. J., Brooklyn, N. Y.

**Transmission Machinery**  
Franklin Machine Co., Providence, R. I.  
Hunter, James, Machine Co., North Adams, Mass.

**Tubes, Paper**  
Pairpoint Corp., New Bedford, Mass.

**Ventilating Apparatus**  
General Electric Co., Schenectady, N. Y.  
Philadelphia Drying Machinery Co., Philadelphia.

**Waste Preparing Machinery**  
Smith & Furbush Machine Co., Philadelphia.

**Water Softeners**  
Scaife & Sons Co., Wm. B., Pittsburgh, Pa.

**Water Wheels**  
Davis Foundry and Machine Works, Rome, Ga.

**Winders**  
Payne, Geo. W., Co., Pawtucket, R. I.

**Wool Oil**  
Borne, Scrymser Co., Bradford Oil Co., Lynn, Mass.

**Woolen and Worsted Machinery**  
Hunter, James, Machine Co., No. Adams, Mass.  
Jefferson, Edward, Philadelphia.  
Philadelphia Drying Machinery Co., Philadelphia.  
Smith & Furbush Machine Co., Philadelphia.

**Yarn Dressers**  
Franklin Machine Co., Providence, R. I.

**Yarn Testers**  
Scott, H. L. & Co., Providence, R. I.

**YARNS, THREADS, ETC.**  
(Artificial silk)  
Mindlin & Rosenman, New York.

**Cotton Yarn**  
Dana Warp Mills, Westbrook, Me.  
Jamieson, James B., Boston.  
Mindlin & Rosenman, New York.  
Rivers & Lewis, Fall River, Mass.  
Sternberg, Fred. & Co., New York.  
Textile Yarn Agency, New York.  
Tolar & Hart, New York.  
Whitman, William, Co., New York.

**Glazed Yarns**  
Jamieson, James B., Boston.  
Mindlin & Rosenman, New York.

**Sternberg, Fred., & Co.,** New York.  
Whitman, William, Co., New York.

**Linen, Hemp, Jute, Flax, Etc.**  
Fawcett, Hughes, New York.  
Mindlin & Rosenman, New York.

**Mercerized Yarns**  
Jamieson, J. B., Boston.  
Sternberg, Fred. & Co., New York.  
Whitman, William, Co., New York.

**Merino Yarns**  
J. B. Jamieson, Boston.  
Mindlin & Rosenman, New York.

**Silk Yarns**  
American Silk Spinning Co., Providence, R. I.  
Cheney Bros., New York.  
Textile Yarn Agency, New York.

**Woolen Yarns**  
Fred S. Gilley, Boston.  
Jamieson, James B., Boston.  
Mindlin & Rosenman, New York.  
Textile Yarn Agency, New York.

**Worsted Yarns**  
Fred S. Gilley, Boston.  
Mindlin & Rosenman, New York.  
Textile Yarn Agency, New York.  
Whitman, William, Co., New York.

In Writing Advertisers Kindly Mention "Textiles"



# ALPHABETICAL INDEX TO ADVERTISERS

Allen, Wm., Sons Co. ....	7	Lombard Foundry & Mill Supply House.....	43
American Pad & Textile Co. ....	41	Loper, Ralph E. ....	41
American Silk Spinning Co. ....	35	Lowell Textile School .....	40
Atlantic Dyestuff Co. ....	34		
Barber Mfg. Co. ....	44	Merion Worsted Mills .....	35
Borne, Scrymser Co. ....	8	Metz & Co., H. A. ....	32
Bradford Oil Co., Inc. ....	2	Mindlin & Rosenman .....	35
Bradley, A. J. Mfg. Co. ....	45	Morningstar & Co., Chas. ....	37
Brinton, H. Co. ....	2		
Carrier Engineering Corporation .....	Front Cover	National Aniline & Chemical Co.....	31
Clift & Goodrich .....	38	National Silk Dyeing Co.....	39
Cohen & Sons, B. ....	45	New Bedford Textile School .....	40
Cooley & Marvin Co. ....	Front Cover	Newport Chemical Works, Inc.....	34
Corey Co., William .....	36	Norwood Engineering Co. ....	4
Crane Mfg. Co.....	42	Nye & Tredick Co.....	42
Crown Mills .....	41	Original Bradford Soap Works .....	40
Daily News Record .....	38	Pairpoint Corporation, The .....	8
Dana Warp Mills.....	44	Parks-Cramer Co. ....	3
David & Co., Inc., S. R. ....	35	<b>Payne Co., Geo. W.</b> .....	39
Davis Foundry and Machine Works .....	43	Pearson, Jos. T.....	44
Delahunty Dyeing Machine Co. ....	40	Philadelphia Drying Machinery Co. ....	9
Du Pont de Nemours & Co., E. I.....	10	Providence Dye Works .....	33
Dye Exchange Corporation .....	32		
Eastman Machine Co. ....	47	Rivers & Lewis.....	44
Economy Baler Co. ....	45	Roessler & Hasslacher Chemical Co. ....	35
Electric Smelting & Aluminum Co. ....	40	Roy & Son Co., B. S. ....	37
Farbwerke-Hoechst Co. ....	32	Scaife & Sons Co., Wm. B. ....	45
Fawcett, Hughes .....	44	Shamow Shuttle Co. ....	41
Franklin Machine Co. ....	40	Sheridan, E. L. & Fred .....	43
General Electric Co. ....	Back cover	Smith & Furbush Machine Co. ....	Front cover
General Silk Importing Co. ....	Front cover	Southern Spindle & Flyer Co. ....	43
Gilley, Fred S. ....	41	Stafford & Holt .....	Second cover
Healy, John J. ....	41	Sternberg, Fred & Co. ....	44
Hellenic Chemical & Color Co., Inc. ....	32	Swan & Finch Co. ....	5
Hotel Martinique .....	4	Tagliabue Mfg. Co., C. J. ....	1
Hunter, James, Machine Co. ....	Third cover	Textile Machine Works .....	Second cover
Huse & Sons, W. D. ....	6	The White Tar Aniline Corp. ....	39
Jamieson, J. B.....	44	Tolar & Hart .....	44
Jefferson, Edward .....	Third cover	Tolhurst Machine Works .....	2
Jenks Co., H. F. ....	45	Tompkins Bros. Co. ....	47
Jennison Co. ....	45	United States Conditioning & Testing Co.....	44
Klipstein & Co., A. ....	33	Universal Cutter Co. ....	8
Laconia Needle Co. ....	6	Warren Soap Mfg. Co.....	39
Lamb, J. K., Textile Machinery Co. ....	41	Wernick, Harry C. ....	38
Litchfield Shuttle Co. ....	37	Whitman, William Co., Inc.....	44
		Wildman Mfg. Co. ....	Third cover
		Wildt & Co. ....	40
		Wolf, Jacques & Co. ....	33
		Worcester Steam Boiler Works .....	7

**In Writing Advertisers Kindly Mention "TEXTILES."**