

The Weaver's Journal

\$4.00

Volume VI, Number 3, Issue 23

Winter 1981-82



- In this issue:*
- Fashion Trends
 - Cotton Garments
 - Weaving Program for Computers
 - Steel Doup Heddles



July 15-18, 1982

convergence 
seattle 

2161 East Hamlin Seattle, Washington 98112

**FROM THE LAND
 WORLD-FAMOUS FOR
 BEAUTIFUL WOOL...**



We're proud of the range, quality and packaging of our fine New Zealand wools.

Our colour catalogue presents samples of top quality pure bred New Zealand wools, both in fleece and carded form, ready for spinning. For weavers, we have natural coloured yarns.

Our comprehensive catalogue shows it all. It will be yours by return airmail when you send \$2.00 (refundable) to:

New Zealand wools leave each farmers' shearing shed in bales up to 350lb each. We have captured the essence of the New Zealand wool scene with a replica bale - our compact, convenient "MINI BALE" of up to 4lb.

Peter & Margaret Black,
 Golden Fleece (1981) Ltd & Co.
 P.O. Box 40(H) Manakau,
 Levin, New Zealand.

**Golden
 Fleece**
 NEW ZEALAND

Visa and trade enquiries welcome

**MACOMBER
 LOOMS**

THE KEY TO YOUR
 WEAVING DESIGNS

DESIGNER'S
 DELIGHT®

THE DOBBY WITH A
 DIFFERENCE

Beech Ridge Road
 York, ME 03909
 207-363-2808

MACOMBER LOOMS

A microcomputer that controls the harness tie up and treadling sequence of your pattern. You can add it on to your standard Macomber loom in less than one hour with simple tools, or order as an accessory on your new Macomber loom giving you two looms for the price of one conventional dobby loom.

Conventional dobby looms lock the weaver into a preprogrammed pattern without allowing for correction or modification of the pattern during weaving.

The DESIGNER'S DELIGHT overcomes this limitation with three selection modes.

Design Mode - design, change, correct, and record the pattern as you weave it.

Automatic Mode - preprogram your pattern, step on the pedal, throw the shuttle and weave.

Manual Mode - when you just want to play or experiment and not record your pattern.

In addition your pattern may be displayed at any time on the L.E.D. display. The DESIGNER'S DELIGHT features single pedal operation, permanent storage of your tie up, and permanent storage of your treadling sequence on separate keys for future use. For example you may use the same tie up key but different treadling keys for many patterns.

This unique yet simple device allows us to offer up to 32 harnesses capacity in 24"-72" weaving widths with single pedal operation.

Get the best! Buy a MACOMBER LOOM.
 Ask the weaver who owns one.

For further information call or write
 MACOMBER LOOMS Beech Ridge Road York, ME 03909 207-363-2808

The Mannings

ANNUAL HANDWEAVING SHOW

APRIL 10 THRU MAY 2, 1982

Handweavers and fiberists from the United States and Canada are invited to participate in our 9th National Show. Every piece submitted will be hung. Limit one entry per person.

PURPOSE: To encourage quality and excellence in the art of weaving.

CATEGORIES: Traditional Weaving
Handspun Hand Dyed Handwoven
Handwoven Rugs
Weaving You Can Wear
Tapestry
Weaving for Home Interiors
Fiber Manipulation

SCHEDULE: Mailed and hand carried entries received March 15 thru March 29.
Show dates — April 10 thru May 2.
Mailed and hand carried entries returned May 3 thru May 8.

Brochures will be mailed out after January 1, 1982. Address your inquiry to:

The Mannings

R. D. 2, EAST BERLIN, PA 17316
(717) 624-2223

DOOPHLICQUE

• • • • •

- It is so simple and easy that anyone could weave on it, even a child, an invalid, the handicapped.
- It warps and weaves quickly and the whole weaving can be seen as you progress.
- It saves warp as compared to a table loom—the extra yard for tying on is eliminated.
- It doesn't take a lot of strength and is good finger exercise.
- It's probably the most relaxing loom there is. It's light weight, fits comfortably in your lap whether you're in a chair, on the floor, in a hospital bed, or in the car.
- It even is an attractive piece of art just sitting warped on the living room floor!

Things that are fun to make on the Doophlicque loom are fetish—pillows, puppets, lampshades, tote bag, hats, stocking caps, bolsters, hand or foot warmers, stuffed animals, baby sweaters or huntings, even a vest or a coat.

The best part is that there are no edges to sew together!

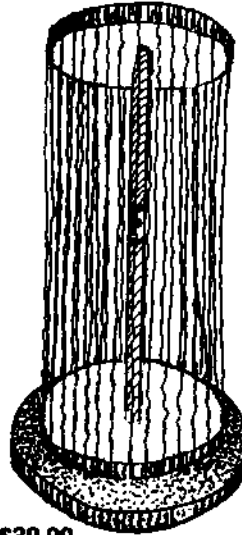

\$30.00
10" x 24"

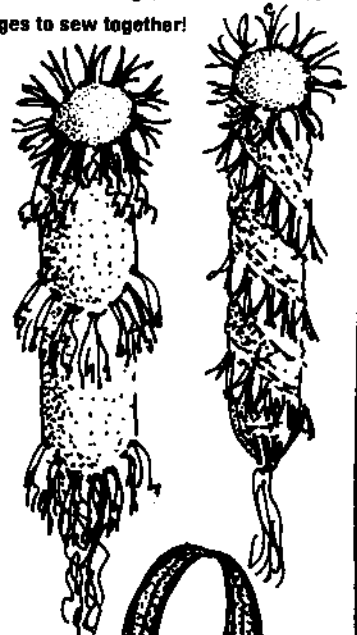

NEW from **Weaver's Way**

The people that introduced a new and unique yarn to handweaving - The ALTERNATIVES, Verel* Handweaving Yarns - now offer these additional quality products:

LINEX in 6 / 2 and 3 / 2, the look of linen with the easy care of Verel.

ALTERNATIVE LACE, a ratiné yarn in Beige, Flax or White Verel.

MERCERIZED PERLE COTTON in Natural and White, 20 / 2, 10 / 2, 5 / 2, 3 / 2.

COTTON NOVELTY YARNS:

WEAVER'S LACE, a ratiné in natural.

DAISY CHAIN, a compact loop yarn.

COTTON IVY, a seed yarn in natural.

COTTON VINE, a nub yarn in natural.

THISTLEDOWN, a chenille in natural.



Weaver's Way

306 E. Goldsboro Street
Crown Point, Indiana 46307
(219) 663-1406

To receive our free catalog and sample cards, please send three twenty-cent stamps for postage.

* Eastman registered trademark.

NAME _____
last first

ADDRESS _____

city country or state zip code

QUANTITY _____ DOOPHLICQUE LOOMS at \$30.00 each ppd.

PLEASE MAKE CHECKS OR MONEY ORDERS, IN U.S. FUNDS, PAYABLE TO DOOPHLICQUE LOOMS. BLUE HILL FARMS #2049, DEWEY, AZ 86327

Weavers' Loft

Intensive classes in weaving.

Instruction on Swedish looms by internationally known Swedish weaver, Lilly Bohlin. All aspects of weaving are explored as well as spinning and design. Glimakra and Lillstina looms and Scandinavian yarns for sale.

Lilly Bohlin Handweaving School and Studio
1021 Government Street
Victoria, British Columbia V8W 1X6
Tel: (604) 388-6306

WEAVING KITS HERE AT LAST!

Step by step instructions on how to weave many beautiful projects. Quality yarns included for all kits. Please send \$1.00 for our price list and yarn samples.

Pillows * Purses * Placemats
Tablecloths * Clothing * Tapestries

Reflections of Weaving
2808 Redwood Road
Napa, CA 94558

LETTER FROM THE EDITOR

Garments must be the favorite projects of most weavers. The response to each Winter issue, in which we tend to feature more material on fashion, is always overwhelming. This year, in which the designers emphasize the folkloric, the shawls, sweeping capes, braided trim and luxurious textures, is certainly the time to go to the loom and create for the wardrobe. This issue is full of ideas and details for successful projects. But where does the inspiration come from? A time-honored answer to that question is captured in the cover photo. A pleated skirt by Antoinette Tessier of Quebec and the seashell which inspired it in a photographic composition by her husband Yves.

With this issue we are starting two new departments: Mailbag and Coming Events. In the past, the staff of *The Weaver's Journal* were the only people to enjoy or to feel chagrin over letters mailed to us by our readers. These letters express ideas, concerns and comments that are shared by many. We decided to publish them (or excerpts) in order to establish a closer tie among people concerned with handweaving and spinning. The Coming Events column also will help establish better communication between the planners of shows, competitions, workshops and those who are looking for these opportunities.

Again, we want to encourage our readers to share their technical knowhow, their ideas and their successful projects with other fiber people. Unsolicited articles are welcome and will be reviewed for publication. At this time we want especially to hear from those of you who work with linen (growing, spinning, weaving, dyeing) and those of you who *intentionally* felt your handwovens.

Weave something handsome and let us know about it!

Best wishes from
Clotilde Barrett

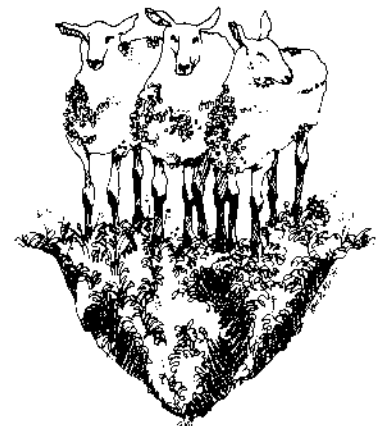

YOU DESERVE THE BEST FROM THE WALKING WHEEL

Handweaving yarn and supplies.
Specialized and unique fibers for spinning.
Ask about our custom warp chain service.
Full-color catalog of yarns, looms and supplies.
Visit our store when you are in the San Jose area



For catalog, send \$1.00 to:
The Walking Wheel, Dept. F
2498 Stevens Creek Blvd.
San Jose, CA 95128 (408) 297-YARN

Freight Free up to \$50

110 + handweaving looms from
● GLIMAKRA ● NORWOOD ●
LECLERC ● HERALD ● BEKA

PIPI CRAFT, LECLERC
& ASHFORD
SPINNING WHEELS

*Complete book of
catalogs available, \$3
(deducted from first purchase)*

THE GOLDEN HEDDLE

1602 Rochester Rd.
P.O. Box 761-WJ
Royal Oak, MI 48068
(313) 547-9159



JACOB ANGSTADT DESIGNS

Jacob Angstadt
His Weavers Pattern Book

Jacob Angstadt Designs
Drawn from
His Weavers Pattern Book

TWO BOOKS REVEAL 18th CENTURY MASTER WEAVER'S RECORDS

A photographic replica of Jacob Angstadt's pattern book: 307 coverlet and tablecloth drafts; 237 tie ups for point twill drafts on 6, 8, 12, 16, 20, 24, 28 and 32 shafts. Companion book contains nearly 500 drawdowns from the profile drafts and point twill tie ups. Designs adaptable to unit weaves on 5 to 10 shafts. Prepared by Ruth N. Holroyd with Ulrike L. Beck
8 1/2 x 11" Hardbound set totaling 400 pages. \$39.95 per set*

Published & Distributed by:

Ruth N. Holroyd
20 Old Farm Circle
Pittsford, N.Y. 14534 U.S.A.

Add \$2.00 Postage & Packaging (\$3.00 overseas) per set—*N.Y. State Residents add 7% tax - Dealer inquiries invited

NOW AVAILABLE!

Seminar or Workshop: "Playing with Profiles". Interchanging unit weave systems within multi-harness profiles. Inquire. Ruth N. Holroyd, Instructor

The Weaver's Journal

Quarterly Journal for Textile Craftspeople

Volume VI, Number 3, Issue 23 Winter 1981-82 ISSN #0160-3817

ARTICLES

- 6 **Fashion Trends**
8 **The Free and Casual Look—Wool Jacket**
by Lorraine McGalliard
10 **Barbara Knollenberg, Fashion Designer**
12 **Gala Raincoat**
by Dini Moes
14 **Fashions by Linda Knutson and Lynn Daly**
20 **Textured Cottons**
Dress and Sauna Robe
by Sue Henrikson
Seamless, No-Sweat Shirt
by Peg Rasmussen
26 **Long Sweeping Evening Cape**
by Bettie G. Roth
28 **Yarn Count Systems**
29 **Weaving as a Professional**
by Janet Checker
30 **Rags to Riches**
Ragstrip Vest
by Pam Scheirman
Honeycomb Bolero-Style Vest
by Phyllis K. Barrett
Jacket from Rags
by Britta Brones
33 **An African Strip-Cloth Shirt—Without Strips**
by Eileen O'Connor
35 **Garments by Hanni Bureker**
38 **18th Century Mollie Costume**
by Kathy Spray
39 **Accessories**
Stylish No-Sew Hat
by Barbara Anderson
Bags
by Nancy Meiling
41 **Multiple Shaft Weaving—Tie-Ups for 2-or-More-Tie Block Weaves**
42 **A Short and Sweet Drawdown Program for Computers**
by Earl Barrett
44 **Rug Weaving: Rug Yarns**
by Martha Stanley
46 **A New Look at Twills**
by Janet A. Hoskins
47 **Universal Tie-Up for a 4-Shaft Countermarch Loom**
48 **Leno with Steel Doup Heddles**
by Clotilde Barrett
50 **Weaving in San Francisco—Part II**
by Evelyn Bingham Prosser
54 **A Special Andean Tubular Trim—Woven Without Heddles**
by Adele Cahlander, Ed Franquemont and
Barbara Bergman

DEPARTMENTS

- 2 **Letter from the Editor**
3 **Advertisers Index**
4 **Mallbag**
5 **Good Ideas from our Readers**
59 **Book Reviews**
62 **Product Reviews**
63 **Product News**
63 **Coming Events**
64 **The Weaver's Market—Classified**
64 **Errata**

Cover photo by Yves Tessier

Editor and Publisher: Clotilde Barrett
Associate Editor: Mary Derr
Advertising: Margaret Martin
Circulation: Maxine Wendler
Photography: Earl Barrett & Jan Carter
Production: Ellen Champion
Staff Artist: Kay Read
Typeset by WESType Publishing Services, Inc.
Printed by Mountain West Printing and Publishing, Ltd.
Color Separation by Spectrum, Inc.

ADVERTISERS INDEX

Anderson Ranch Arts Center 23
Arrowmont School of Arts and Crafts 61
Ayotles' Designery 58
Bradshaw Manufacturing Co. *ibc*
Classified Ads 64
Colorado Fiber Center 5
Colorado Fiber Center C
Convergence '82 *ifc*
Doaphlicque Loom 1
Dyeworks 64
Glimakra Looms 'n Yarns, Inc. *back cover*
Golden Fleece *ifc*
The Golden Heddle 2
Grandor Industries Ltd. 49
Harrisville Designs 13
Henry's Attic 19
Holroyd Ruth N. 2
Ironstone Warehouse *ibc*
Lucille Landis 23
Macomber Looms *ifc*
The Mannings 1
The Mannings 4
Katherine Ramus
Reflections of Weaving 2
Restoration Arts *ibc*
School Products Co., Inc. 13
Serendipity Shop *ibc*
Siewers Looms 4
Silk City Fibers *ibc*
Traditional Handcrafts 19
The Walking Wheel 2
The Weaver's Loft 23
Weaver's Loft 2
Weaver's Way 1
Wild Yarns 7
The Wool Gallery 4
The Wool Shed *ibc*

The Weaver's Journal is published on the first of each January, April, July and October by the Colorado Fiber Center, Inc., P.O. Box 2049, Boulder, Colorado 80506. Telephone (303) 449-1170, 444-2088. Subscription rates are \$15.00 U.S. Currency for 1 year (4 issues) or \$29.00 U.S. Currency for 2 years (8 issues). Colorado residents add 3% sales tax. Outside U.S.A.: 1 year \$18.00 U.S. Currency, 2 years \$34.00 U.S. Currency. Copyright Colorado Fiber Center, Inc., 1982. Second-class postage paid at Boulder, Colorado and additional mailing offices. *The Weaver's Journal* USPS 584-210. The editorial committee takes no responsibility for the goods advertised in this journal. POSTMASTER: Send address change form 3579 to *The Weaver's Journal*, P.O. Box 2049, Boulder, CO 80506.

MAIL BAG

"I am delighted with the Summer '81 copy of *The Weaver's Journal*. The thing that caught my eye was the insulated window coverings. Where can one obtain the "Astrolon" lining?"

Joyce L. Johnson
Boadsbury, PA

Editor: Astrolon Aluminized reinforced polyethylene film is manufactured by: Ingly Sealy Thermos Co., 37 E Street, Winchester, MA 01890.

"*The Weaver's Journal* gets better all the time. I'm always brightened when I see the white envelope in my mail. I would like to suggest that a nice addition would be a section devoted to information about your authors; perhaps a sentence at the beginning of each article offering a brief description of his/her work and accomplishments or a section "About Author" at the back of the issue. Thanks."

Ellen R. Donaldson

Editor: The point is well taken. Our contributors deserve to be better known to our readers. We have often included paragraphs about the author at the end of the article, and we will try to do this more consistently.

"*The Weaver's Journal* is a delight and an inspiration to me. Finishing directions in some of the earlier issues were very helpful. More, more!"

"The current issue (Summer '81) is absolutely inspirational. I too have no wall space for tapestries, but many many windows with heat loss. Can't wait to get back to my loom!!"

Dee Jones
Nevada City, CA

"I have just discovered an article in *The Weaver's Journal* Summer 1981 on ecclesiastical weaving. I am not able to buy a copy now and wonder if you sell back issues or articles?"

Peggy Miller
Cincinnati, OH

Editor: Copies are available for most back issues. Those that are out-of-print can be purchased in photocopy form.

"Yesterday at the Mountain Spinners & Weavers Guild of Prescott, AZ—of which I am a member—I saw several issues of *The Weaver's Journal* and was very much impressed with them. In fact, I'm taking a year's subscription through the guild."

Helen W. Skirm
Tempe, AZ

Editor: Many guilds have taken advantage of our offer of a free 1 year subscription to *The Weaver's Journal* for the guild library when they send us nine 1 year subscriptions to the journal together in one envelope. (A 2 year subscription counts as two of the nine.)

"I would like to order *The Weaver's Journal* for 2 years. . . .

Could you start my subscription with the Summer issue 1981? I saw this issue at our Springfield Fiber Artist Meeting last night. I saw the article by Brother Kim Malloy and I am interested in all types of Ecclesiastical weaving. As I glanced at it, it seemed to be what I am looking for. Brother Kim was at the Midwest Weavers Meeting in June.

I have been debating on whether I should subscribe to *The Weaver's Journal* and the summer issue was my answer."

Olive E. White
Springfield, MO



"a happy marriage —"

That's how a student-customer described her experience here at Sievers.

Excellent, high quality Sievers looms and spinning wheels and the most rewarding instruction you could imagine—a "marriage" if you will. This summer there will be over thirty courses taught by twenty two qualified teachers.

If you want the best in proven equipment or if you need pleasant, warm guidance, then be sure to write for all the information—it's free.

SIEVERS LOOMS, SPINNING WHEELS and SCHOOL OF FIBER ARTS

Walnut St. Washington Island, WI 54246

Happiness is in Your Hands—and it Keeps You Young!

THE MANNINGS

HANDWEAVING SCHOOL AND WEAVERS SUPPLY CENTER

HANDWEAVERS —

Weaving Instruction — Resident instruction in all types of weaving. Special classes for beginners. Pre-registration necessary.

Rug Wool — Over 300 colors. 2-3-4-6 ply.

Yarns — Stanley Berrocco — Manos del Uruguay — Indiecita (100% Alpaca) — Fawcett Linens — Lily Cottons — Chenilles and many other novelty yarns.

Looms — Gallinger — Leclerc — Dorset in stock for immediate delivery.

HANDSPINNERS —

Spinning Instruction — 1 day course. 9-4 daily. Pre-registration required.

Spinning Supplies — Saxony, Castle and Walking Wool Wheels — Carders — Drop Spindles — Carding Machines — Distaffs.

Fibers — Camel Alpaca-Goat — Angora Rabbit — Yak — Mohair — Flax — Wool Roving — Silk Noil — Tussah Noil — Natural and Dark Fleece.

VEGETABLE DYERS —

Dyestuffs — Mordants — Dyebarks — Lichens — Special Skeined White Wool.

For catalog and rug wool samples, send .50 to:

The Mannings

R. D. 2, EAST BERLIN, PA 17316
1-800-233-7166 PA call (717) 624-2223

Full color range of Bergå yarns and Helmi Vuorelma yarns

(samples on request)

Handwoven textiles
Rasmussen looms
Finnish weaving tools

Caryl Gertenrich

459 High S.E.
Salem, Oregon 97301
(503) 363 9665



*** good ideas from our readers

TUBULAR KNITTED EDGING

Here are some instructions for an ingenious good looking edging for woven (and knitted) goods. The idea comes from master knitter Elizabeth Zimmermann, who has kindly given permission to publish this adaptation. Instructions for its use in knitting can be found in her delightful book "Knitter's Almanac" published by Scribner's and available from Elizabeth herself, box 57, Babcock, Wisconsin 54413.

This is a tubular edge, knitted on double pointed needles. In each row, one stitch is picked up from the woven edge and one is decreased. The knitted edging should be soft. Change needles until you get the desired effect, since yarns may be doubled or tripled. For my sample I used #4 needles and sport weight yarn.

On a double pointed needle, cast on 3 stitches, pick up one stitch from the woven edge. Slide stitches to other end of the needle (thread in back) *knit 2, slip 1, knit 1, pass slipped stitch over, pick up a stitch from the woven edge, slide to other end of needle and repeat from*.

In picking the stitches, keep watching to make sure the knitted edge is not drawing up. If it is, pick up more stitches to the inch. This will vary with every yarn, needle and knitter, so it just isn't possible to give a rule of thumb.

To end, cast off 2 stitches and leaving a 6" (15 cm) tail of yarn, draw tail through loop, thread it into a yarn needle and tack the end down neatly.

Try this on a sample to see which side is the right or wrong side for you. They both look good. The name? Idiot Cord.

Dee Jones

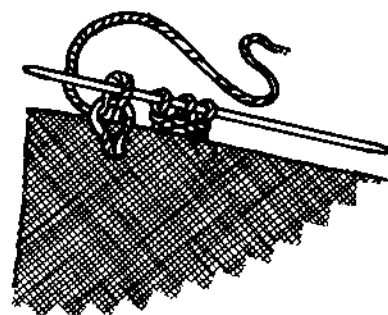
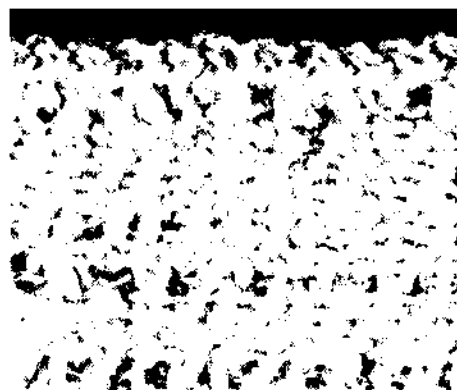

SLING BRAIDING OF THE ANDES



ADELE CAHLANDER

WITH ELAYNE ZORN
AND ANN POLLARD ROWE

Weaver's Journal Monograph IV

SLING BRAIDING OF THE ANDES

by Adele Cahlander

with Elayne Zorn & Ann Pollard Rowe

ISBN 0-937452-03-3

Library of Congress Catalog #80-67114

Illustrated with Color
and Black/White Photographs and
with Line Drawings

Published by

Colorado Fiber Center, Inc.

With the help of a grant
from the National Endowment for the Arts

ABOUT THE BOOK

Slings have been used since before the time of David and Goliath. Shepherds used slings to guide their sheep and to protect the sheep from marauding animals. In the Andes, slings took on ceremonial importance as well. Through the years, they were developed into works of art.

How the intricate braids were actually made has long been a mystery. This monograph is the first true documentation on the way the slings were constructed. During field work among the remote highland herders, Elayne Zorn learned the basic techniques on which this book is based. Through the close cooperation of Ann Pollard Rowe and Irene Emery of the Textile Museum in Washington, D.C., a suitable terminology was provided.

Price: \$11.00 Postpaid

Please make checks or money orders, in U.S. funds, payable to: The Weaver's Journal, P.O. Box 2049, Boulder, Colorado 80306 (U.S.A.)

NAME _____

ADDRESS _____

City State or Country Zip

ENCLOSED:

W.J. Monograph IV \$ _____

\$3 extra for other countries if

AIR MAIL is desired \$ _____

TOTAL \$ _____

fashion trends

compiled by kate nelipovitch and susan hick



No matter what your personal style, there's something you can pull for yourself from this fall's fashion offerings - and adapt it to your handwoven garments.

Designers have been thinking Big. The Biggest of the Big news is the **Big Sweep**, which is a fancy term for the ubiquitous shawl. Now the shawl is over-sized, even to afghan proportions. You can let it grow into a fabulous, dramatic cape. It may be a triangle, a square, or a rectangle. Corners may be left at right angles or rounded off. It may have fringe or be hemmed and trimmed all around with braid. Try it striped, as a plaid, tweedy, checked, and double-woven for a two-in-one warp. Add a metallic, even for daytime. Wear it over one shoulder or drape it like a toga or a scrape. Most importantly, wear it over jacket, a sweater, or a coat. And when you're not wearing it, toss it on a couch!

Coats are roomier, cozier, and longer, assuming the throw-on ease of a sweater in generous, unconstructed cuts. One was described as "a coat that slides on with the luxurious ease and warmth of a burmose, to gather around you and belt, to wear over everything and every length."

Jackets are everywhere and worn with everything - skirts, dresses, and pants. The variety is unbeatable! There are short, bolero-style ones and longer, looser ones. Cardigan styles are good. You may suit yourself whether or not to have a collar and lapels and pick your favorite style. Sleeves are larger and may be puffed.

Dresses, too, are abundant. The tent and the smock are just two of the choices. The shift, the dropped-waist with swingy skirt, and the buttoned-up-front dresses are alternatives. Once again sleeves are larger and shoulders puffier. Lengths are up to you; consider what is best on you and combine with your mood of the moment. Another look is the **tunic**. Pick a shape from the dresses described and drop it over a skirt, full or slender, or top a pair of **pants**, which could be knee length, midcalf, just above the ankle, harem, or **culottes**. To belt or not? If you do, make it metallic. And for evening, bare a shoulder.

Colors and textures are tied to the season's buzzword: **FOLKLORICS!** We knew it before as ethnic clothing. This time around we blend ethnic moods by our uses of color, texture, and pattern instead of concentrating on construction and shape.

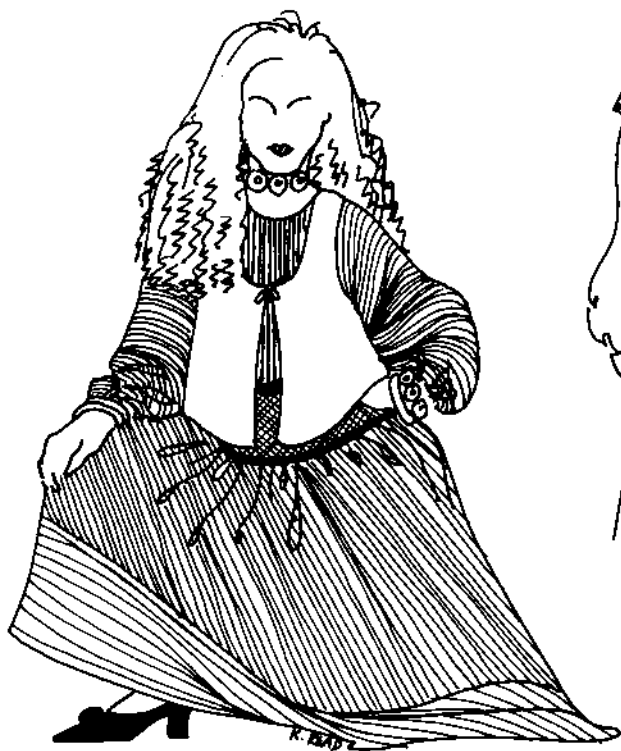

Derivations to consider:

Scotland: deeply-toned tartans.

Britain: subdued tones, the classics, prim and precise details.

The Tyrol: dirndl skirts, curved edges, loden, alpine tones.

Eastern Europe: gypsy touches of warm spice, bold mixing.

Scandinavia: reindeer and snowflakes and Fair Isle patterning.

The Orient: exotic stylized florals, ikat, side closures, high collars, reds.

Native American: geometric pottery and blanket designs, southwestern colors, tiered skirts.

With everything - braid trims, woven trims, and frogs as closures and ornaments!

Combinations are limitless; imagination works here to create your own Folkloric flair, whether it be glamorous or sportive. We've seen an Aztec-printed dirndl paired with a Mandarin shirtjacket. A loden jacket with a ruffled blouse. A "Kimono" coat. A gypsy vest with a lacy blouse. A border stripe on a dirndl. A braided boucle jacket with a pleated skirt.

Besides the colors the Folklorics bring to mind, we must mention those inspired by the metallics: gold, silver, pewter, copper, and bronze. If we still haven't hit your scheme, consider winter white, a tweedy oatmeal, the pinks from coral to clay to raspberry, thistle gray, honey tones, British earth, bog brown, greenish taupe, heathery purple and wood violet, and black as a background for sparkling metallics and rich embroidery.

Don't be timid when it comes to texture! Old favorites have become new. Be soft and brushed with mohair. Or nubby and flacked with tweeds and boucles.

Among weavers individuality will never go out of style. Even though we see the velveteen-blazer-and-challis-skirt costume widely promoted, there is no need for a weaver to be a clone of her neighbor. The fun comes when we use the fashion world's ideas for our unique creations!

WILDE WOOLY



2, 4 & 6 ply in 8 earthy natural wool colors.



natural white wool in various weights and plies.



3 & 4 ply wooly Berber yarns in 5 rustic colors.



sturdy 3 ply wool in 16 subtle shades.



fine 2 ply wool for warp or weft in 28 custom dyed colors.



the Heavyweight - a bulky wool yarn in 9 bold colors.



carded wool in white and natural colors.



carded wool in 9 dyed colors.

Send \$3.00 for sample cards.

WILDE® YARNS

for HANDWEAVING

Custom Spun by
John Wilde & Brother, Inc.
3705 Main Street, Dept. W
Philadelphia, PA 19127

A Tradition in Spinning Since 1880



THE FREE AND CASUAL LOOK WOOL JACKET

by Lorraine McGalliard

This basic jacket is designed for comfort, durability and warmth. Its classic style will always be in fashion. The overshot pattern gives the garment a folkloric look which is so popular in this year's styling.

The jacket is fun to weave and can be done on a small four shaft table loom.

To determine the width of the fabric, measure the widest part of the body (hips or bust) and add 3 to 5 inches (7.6 to 12.7 cm) for ease. Divide that number by four and that will give you the width you need. Add 10% for take-up and 1" (25.4 mm) for seams. My measurements come out to 11" (28 cm) and so I put a 13" (33 cm) wide warp on the loom.

Make the pattern pieces out of muslin. Using 11" (28 cm) wide strips, cut them into the lengths needed and tape them together with masking tape to see if the garment fits. Keep in mind that the woven piece will be stiffer. Cut and tape until everything is just right, then use the pieces for the pattern. This gives the necessary information for the length of the warp. I needed 6 yards (5.5 m) finished.

Sketch out the entire yardage on paper (Fig. 1). On each panel mark where the stripes and patterns go. Weave a few picks of tabby in a light weight yarn between each panel to control the raveling when the fabric is cut.

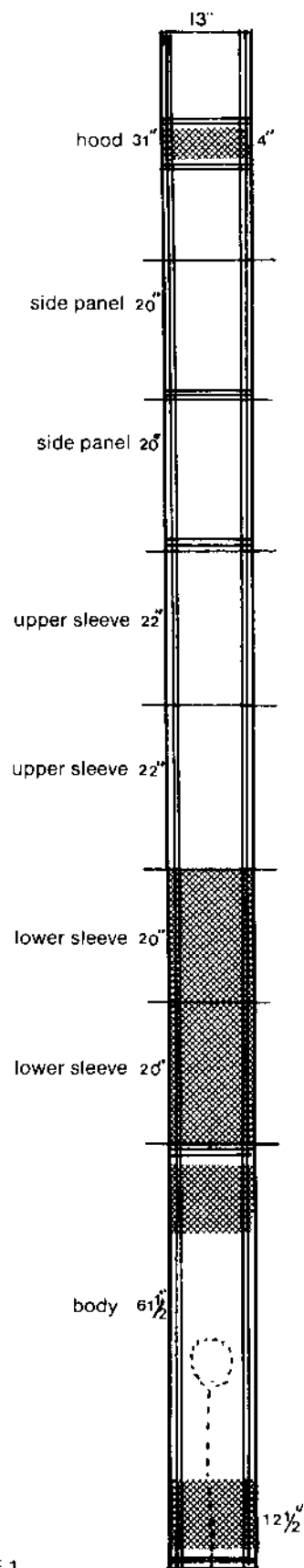

FIGURE 1

WARP: 2 ply wool, color A and B (Condon's Yarns), approx. 872 yards: lb.

WEFT:

Tabby— same as warp (color A)

Pattern— same 2 ply yarn as for the warp (color B) but used doubled.

SETT: 6 epi (25/10 cm)

WIDTH IN THE REED: 13" (33 cm).

LENGTH OF THE WARP: 7 yards (6.4 m).

SUBTLE STRIPE PATTERN IN THE WARP: The main color of the warp is A but use 3 threads of color B 1" (25.4 mm) from each edge and 2 threads of color B 2" (50.8 mm) from edge.

WEFT STRIPES ABOVE HEMLINE: 4 picks of color B 1½" (38 mm) from edge, 2 picks of color B 2" (50.8 mm) from edge.

THREADING, TIE-UP AND TREATING: See Fig. 2.

FINISHING: For the binding I used a commercial wool flannel (½ yard was enough). The binding was cut 1½" (38 mm) wide for a finishing width of ¾" (16 mm). Only the neck binding is bias.

Most of the jacket was sewn together by hand as I didn't want any stitching to show. Most pieces were bound before assembling the jacket.

The inspiration for the jacket came from a workshop with Jean Scorgie.

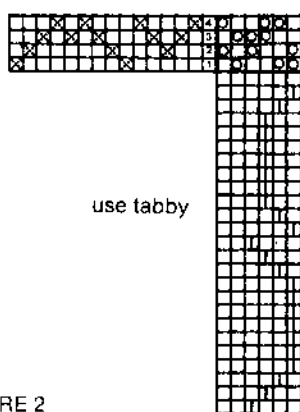

FIGURE 2



DIRECTIONS FOR SEWING JACKET

1. Cut pieces apart and zig-zag edges.
2. Mark front and neck edge seams with wax tailors chalk.
3. Pin or baste bias binding around neck edge on line with right sides together and stitch ½" (12.7 mm) from line edge.
4. Pin or baste straight bindings down fronts on line and stitch ½" from line edge keeping bindings butted together.
5. Cut front and around neck between bindings on line (I zig-zagged along raw edge after cutting).
6. Turn binding to wrong side and sew by hand. (Do not finish neck edge except ½" on each side of front)
7. Baste in zipper and stitch along side of binding or sew by hand using a heavy thread.
8. Sew bindings on selvedge edges of main body and finish.
9. Pin side panels to body and try on to fit. (I took 3" (76 mm) off center of each panel at the arm hole and tapered it down to nothing at the hem).
10. Stitch dart, (if any), finish edges and press flat. Bind the top edge and finish off.
11. Stitch upper sleeves together (leaving a space at the under arm as wide as the side panel) tapering 2" (51 mm) off at edge next to lower sleeve. Bind this edge and finish it.
12. Stitch lower sleeves together and sew to upper sleeves by putting lower sleeve selvedge under binding of upper sleeve. Sew along upper edge of finished binding.
13. Sew side panels to upper sleeves at arm hole putting the sleeve under the binding and sewing to the hand sewn edge of the binding. Edges of sleeve arm hole and side panels must line up.
14. Sew pocket pieces to side panels and front (Use a commercial pattern that has pockets in the seam and follow those directions.)
15. Lay main body bindings (#8) over selvedges of sleeves and side panels and baste. Hand sew these together like the other seams. Stitch pockets together.
16. **Lining**—Use the muslin pieces as a pattern (except the hood) and add seam allowances. Stitch all pieces together.
17. Pin lining along neck edge and baste, wrong sides together.
18. On fronts, turn lining under ½" and hand sew close to zipper.
19. Turn up hem and leave loose or baste along bottom and incorporate with the bindings.
20. Baste sleeve edges together and bind.
21. Bind the bottom edge or hem.
22. **Hood**—stitch binding on both selvedge edges. Finish one edge. (This will be the front of the hood).
23. For hood back, turn binding to right side and press flat.
24. Fold hood and stitch together ¾" (16 mm) from binding seam along flat binding with right sides together. Press seam flat and turn binding under and sew by hand.
25. If you don't want a pointed hood, sew across the point at right angles and trim and bind.
26. Pin hood neck edge to neck edge of jacket with wrong sides together (over lining) and baste along seam.
27. Turn neck binding over and sew by hand. Flip back hood. Wear with pride!



Rainbow Sherbet 1980



Chinese Dress 1978

When I was ten I met a friend who was sewing doll clothes with *real* doll clothes patterns. This event had lasting consequences and caused important changes in my life. Previously I had been creating doll clothes but I used only guesswork and imagination for their cut and shaping. Now I had an inkling as to how *real* clothes took shape and were sewn together and I also came to the realization that I needed some training. This was the beginning of a lifelong pursuit of the knowledge of the design principles and aesthetics of body coverings.

From childhood accomplishments I proceeded to obtain a Textile and Clothing and Art degree from the University of Wisconsin. After four years and a bachelor's degree I still felt a further

Barbara Knollenberg, Fashion Designer: a personal story



The Grass Is Greener 1980



The Sun and Moon and All Between 1979

need to learn, so I then obtained a Textile Arts master's degree. It is during that time that I discovered handweaving and how to create my very own fabrics. During that time also I married a scientist and established a home. Boulder, Colorado was our first home where I opened a clothing boutique call THE PEACOCK. This shop was a lifelong dream become reality. I designed and created every garment in the shop, all of which were made of hand silkscreened fabrics. I was not weaving at this time for I hadn't felt the need to express myself with anything but pure surface design. The first of my three children was soon born and I had to give up the shop, but never the urge to create clothing. I kept some private customers who were willing to be patient and fit into my schedule. We then moved to the Chicago area where I floundered for three years

and developed a need to add depth and dimension to my creations. Back to Boulder in 1970 with a new baby and a new attitude toward my clothing designs—handweaving. I acquired a loom at long last.

My first loomed projects came about after taking a weaving refresher course and after many months of self-study. The sheer amount of technical information I needed to master the set-up of a loom, let alone decide upon my own personal weaving patterns, took years of exploring. However I do believe I have finally come home to my own personal expression as a weaver. I am not a production weaver but an artist who needs to create clothing structures which reveal themselves as complete artistic expressions.



African Bird Jacket 1976



Pine Tree Coat 1975



Boxed Lilies 1979

I've often been asked by my students that I've taught in a few workshops; how do I come by a design? What has inspired me? At first I couldn't give an answer except saying that I worked according to applied art principles, which through all my art training I automatically absorbed. So I then initiated a personal search for ways to help students discover inspiration through specific aids and helps. These are my favorite aids:

- 1 Costume history books
- 2 Commercial fabric publications, i.e., *Elegance* or *American Fabrics*
- 3 Art history books and current art magazines
- 4 Weaving pattern books
- 5 Nature, especially birds, animals, plants, etc.

Handwoven clothing requires more conscious thought in the planning than silk-screen printing of fabric. The true beginning of the design process is the intended purpose of the garment; i.e. for multiple production, for personal wear or mainly for art's sake. Then color is decided upon as well as the weave structure and type of yarns to be used.

When I design I begin with purpose, choose either the yarn, the garment structure or the color from there on, and then decide the weave technique which best suits the intended purpose. Formerly, I made samples of all my new weavings before attempting to even wind a full warp. Now I only weave samples if I am unfamiliar with the yarn or its proper set. I tend to do weavings that are inspired by previous weavings. In the past I wove complicated weave structures with simple untextured yarn in neutral colors, i.e. white, brown, black, gray, etc. Recently I have discovered I love tedious double weave pick-up techniques for creating bold designs of complicated color structures and varying yarn textures.



Queen's Robe 1976

The garments shown here trace the evolution of my work from 1975 to 1980. Each of my garments has been an experiment in some manner. The earlier works were experiments in weave structures and their use. Later works were experiments with various yarns and 3-dimensionality in garments. Today I experiment a lot with proportions and free-form motifs within clothing structure. I do custom clothing pieces as well as experimental art expressions. The art expressions always help me to grow and enable me to create quality classic wearable garments for daily living.

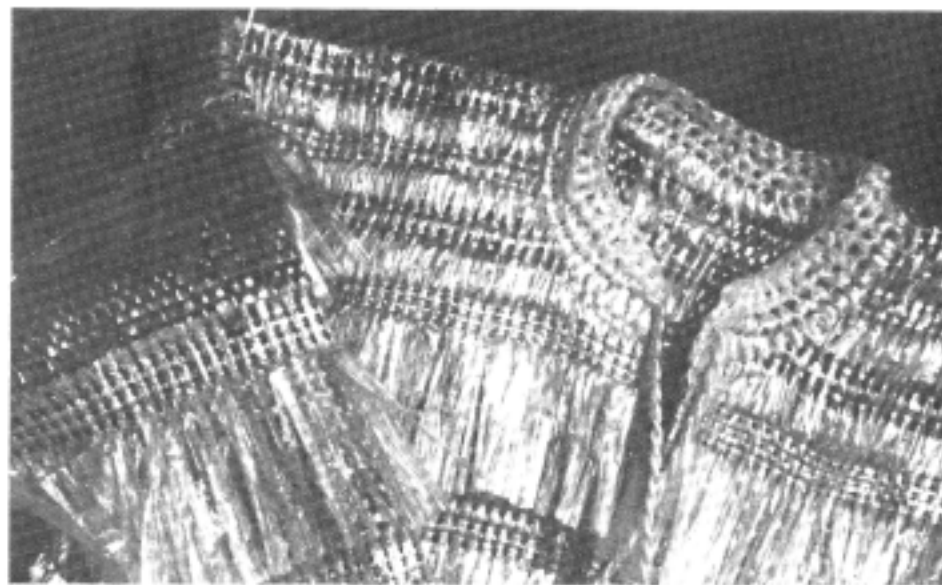

GALA RAINCOAT

by Dini Moes

It was a combination of three things that gave me the inspiration to weave an evening raincoat: four shaft double weave, a picture of a Spanish shepherd's cape made of straw, and a roll of Saran wrap.

The versatility of the four-shaft double weave has never ceased to amaze me. Long sample warps always seem to be too short for trying out various possibilities; the weaving of each sample leads to an idea for another one. My experimentation with warp float and pleated fabric samples, proved to be most fascinating. One day after having cut the floats of one of the samples, the fabric reminded me somewhat of the construction of a Spanish shepherd's cape made of straw pictured on the back flap of the World Crafts Council publication: "In Praise of Hands". Thinking about this, I could see in my mind a multitude of fabrics with cut fringes worn as skirts, capes, jackets, bags and larger items such as bedspreads and rugs all woven with effective yarns suitable for their function. Later that day, when ripping off some Saran wrap to cover leftovers from dinner, the thought struck me

that if I would cut that glittering saran in strips, it would make an excellent material to be used for an evening raincoat woven in the warp fringe technique. I could hardly wait to get started!

Rolls of Saran were marked every 1½" (3.8 cm) and cut through with a sharp knife, each roll giving me nine pieces of 200 feet (61 m) long "thread". To emphasize the luxury of the sparkle of the Saran, I wound it together with silver metallic. From this, my surface layer warp was made.

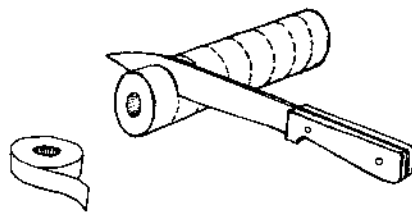

FIGURE 1

For the ground layer of the warp I used artificial straw, two colors alternating, A and B. My choice of colors was purple and turquoise-green.

The simple style of the coat, which requires a minimum of sewing, needs two widths of fabric. Five yards of 13"

(33 cm) wide fabric is used for the body and one yard (91.4 cm), 18" (45.7 cm), wide is used for the sleeves.

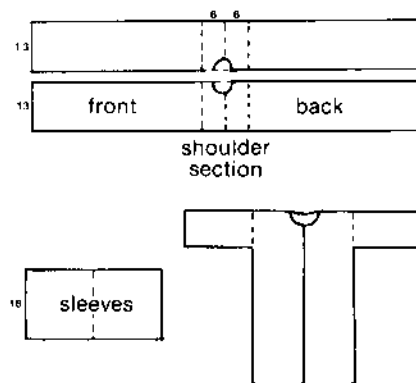

FIGURE 2

The two warps were put on one beam. However, for longer yardage, I would recommend the use of two beams to avoid tension problems.

The loom was threaded with Saran/metallic ends on shafts 1 + 2, artificial straw ends on shafts 3 + 4, colors alternating.

For the weft I cut dry cleaner bags circular in two inch wide strips. The soft plastic gives a better "drape" to the fabric than the rather stiff saran wrap.

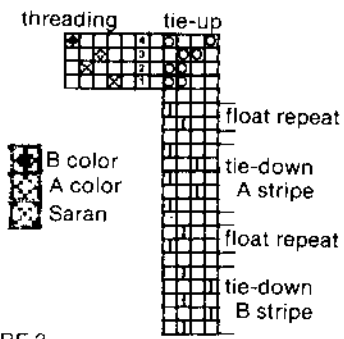

FIGURE 3

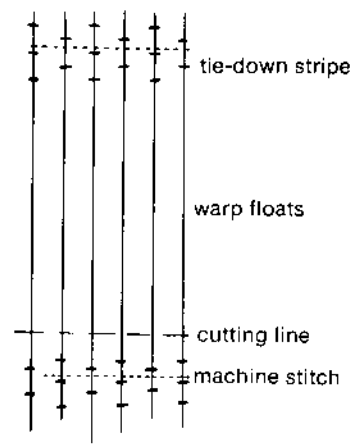

FIGURE 4

The weaving is fast and simple. It is important however, to keep a constant beat throughout so that the woven pieces will match when being sewn together. I made all warp floats 3" (76 mm) long except for the shoulder sections which have floats of 1" (25 mm) long.

FINISHING: After the fabric was removed from the loom, all tie-down stripes were stitched through on the sewing machine with invisible thread to prevent the fringes from slipping out after cutting.

The coat pieces were then sewn together by hand with clear artificial straw. To avoid unraveling, I stay stitched three times around the neckline before cutting out the shape. The neckline was finished with several rows of crochet with dry cleaner bag "Yarn". Hems were put in the ground layers of the coat and sleeves.

Finally, all 3" floats were cut one quarter of an inch from where they re-enter the ground weave.

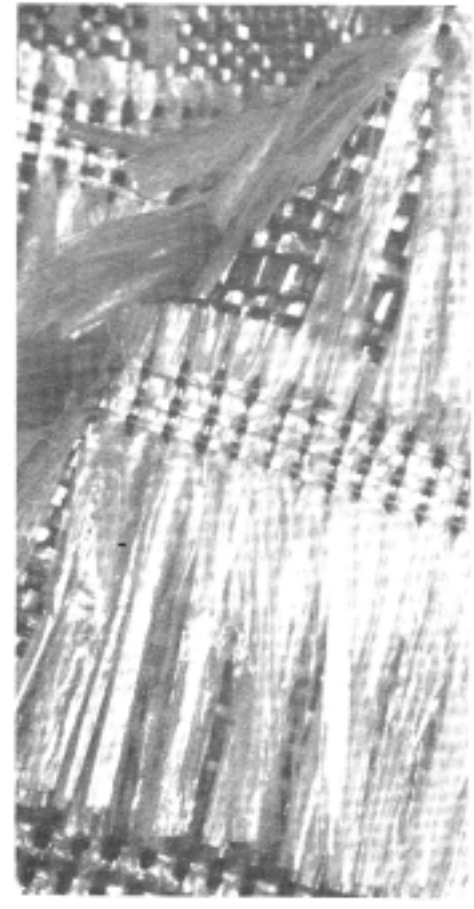

NEW COTTON-LINEN
55% COTTON/45% LINEN

A superb blend of cotton and linen in 28 vibrant colors plus natural. Suitable for both weaving and machine knitting. The put-up is 250 gram tubes (8.8 oz). Comes in 2 weights both in the full color range.

No. C12/2 Cotton-Linen, 1650 yds. per tube
No. C 4/2 Cotton-Linen, 1100 yds. per tube

COLORS:

No. 0 Natural	No. 15 Light Blue
No. 1 Bleached White	No. 16 Med. Blue
No. 2 Lemon Yellow	No. 17 Indigo Blue
No. 3 Golden Yellow	No. 18 Navy
No. 4 Yellow Orange	No. 19 Aqua
No. 5 Red Orange	No. 20 Yellow Green
No. 6 Warm Red	No. 21 Grass Green
No. 7 Deep Coral	No. 22 Forest Green
No. 8 Hot Pink	No. 23 Chartreuse
No. 9 Pink Violet	No. 24 Mustard
No. 10 Cranberry	No. 25 Beige
No. 11 Wine	No. 26 Lt. Brown
No. 12 Lilac	No. 27 Dk. Brown
No. 13 Royal Blue	No. 28 Black
No. 14 Slate Blue	

Give size of yarn and color number in ordering.
\$9.95 per tube
Weaving Catalog \$1.00
Color samples available
DEALER INQUIRIES INVITED

SCHOOL PRODUCTS CO., INC.
1201 Broadway, New York, N.Y. 10001 (212) 679-3516

HARRISVILLE, N. H.
Two centuries of craftsmanship

HD We are makers of:
Dyed Yarns
Natural Yarns
Hand Loom Kits
Weaving Accessories

Complete Sample Catalog \$4.00
HARRISVILLE DESIGNS
Harrisville, N.H. 03450

FASHIONS BY LINDA KNUTSON AND LYNN DALY



Textured jacket, page 15



Double Woven reversible jacket, page 16

photos by Brent Daly

The combined talents of two friends have resulted in a successful garment weaving partnership. Linda's contribution is as a weaver and dyer. Lynn's expertise is in her sewing and finishing abilities. These articles are contributed by both women who work together to create outstanding fashions.



Romantic tunic, page 18

TEXTURED JACKET

Having been working for some time with color as the main focus in our garments, we wanted to experiment using texture as a design element. A jacket combining the velvet-like softness of suede with a heavily textured, lustrous wool yarn was the most successful result of these studies.

Choosing the yarn was the easy part, as we had been greedily eyeing a luscious yarn from Henry's Attic for some time. Called QE2, it is a lustrous boucle spun from the fleece of Lincoln sheep which are noted for the beautiful sheen of their wool.

Locating the leather, however, proved more difficult but after some frustrating trials and errors we were able to obtain nearly any type of hide in the latest fashion colors. Eventually, we selected a lambskin in a rich shade of medium brown. According to the shopowner this type of leather would not stretch when handled and it had a lovely suppleness to it.

Before weaving the fabric it was necessary to dye the yarns to blend with the color of leather. As previously stated, we wanted the texture of the various components of the garment, and not color, to be the focal point.

The warp yarn was dyed a slightly paler shade of the weft yarns to create a more interesting fabric. While we did not want the color to be the focal point, we also did not want the fabric to appear "dead". By using a warp color in a lighter value and choosing weft yarns of various character, one smooth and dull and the other textured and lustrous, a most exciting fabric was created.

Because of the high cost of the boucle yarn we decided to use it sparingly in the fabric by introducing just enough to give an overall appearance of its texture. In addition, the fabric was woven so that most of the texture was on one side. This was accomplished by inserting the boucle under every fourth warp thread. A two ply wool mill end was used as the ground weft for the bulk of the fabric with the boucle inserted in random fashion.



Because the texture of the garment was to serve as the focal point it was decided that a simple closure would be most suitable. For this reason leather covered buttons and braided leather strips were chosen. We were pleased with the finished garment as it had the look for which we were striving.

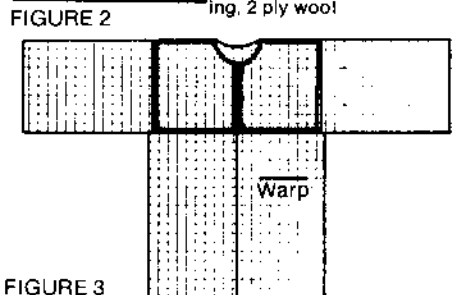
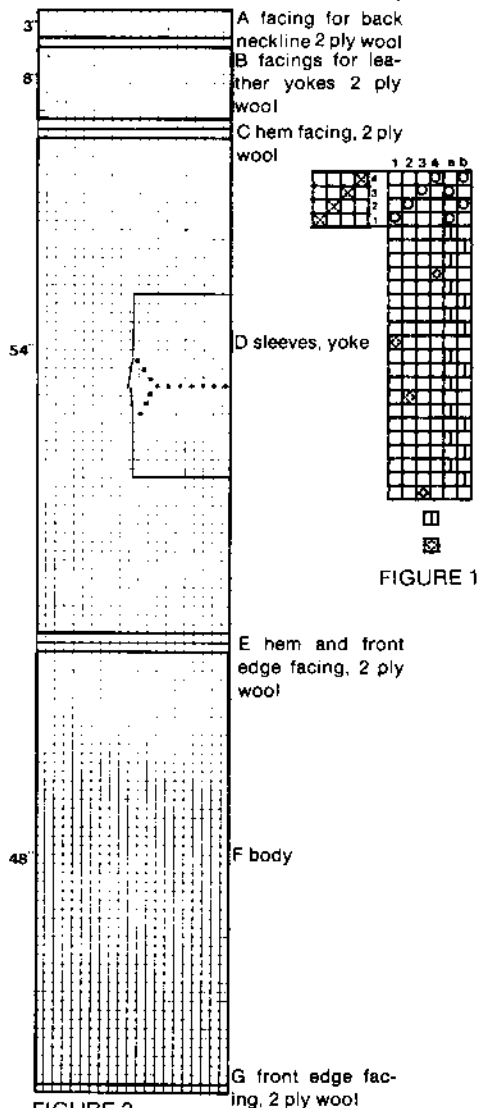

FIGURE 3

WEAVING INSTRUCTIONS

WARP: 20/2 wool

WEFT:

Tabby—2 ply wool mill end, medium weight

Pattern—Boucle (Henry's Attic QE2)

LENGTH OF WARP: 140 inches (3.56 m).

SETT: 8 epi (30/10 cm) sleyed 2,1,1, in a 6 dent reed

WIDTH IN REED: 21 inches (50 cm) (small-medium size)

TOTAL NUMBER OF ENDS: 168

THREADING, TIE-UP AND TREADLING: see Fig. 1

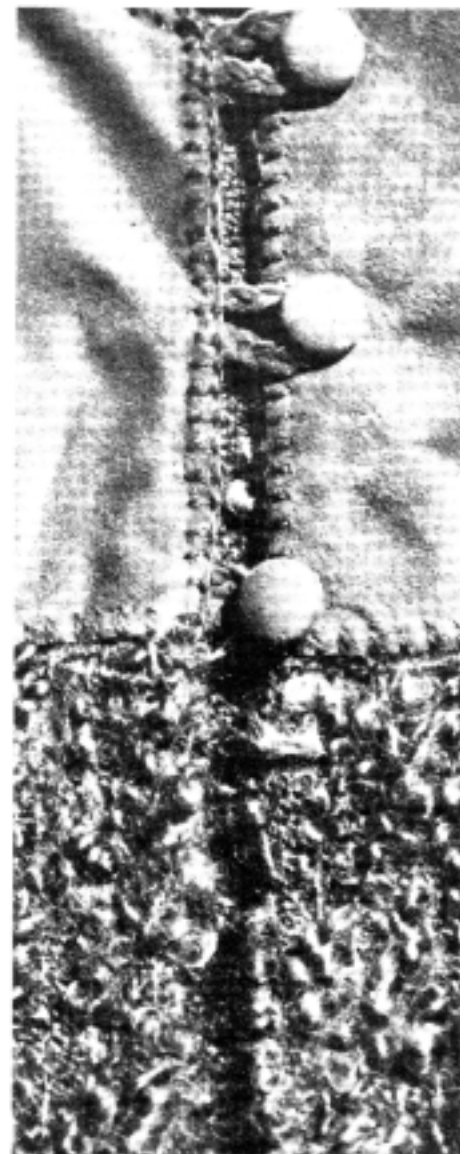

Note braided leather closures and blanket stitch finishing.

DIRECTIONS FOR ASSEMBLING TEXTURED JACKET

1. Machine finish front edges and turn back and hand finish with blanket stitch.
2. Fold sleeve yoke section in half lengthwise. Fold body section with front edges coming together in the center. Place two sections together to determine where underarm sleeve seams will meet body section. Whipstitch sleeve seams.
3. To determine size of leather yoke sections mark center front of sleeve-yoke section and measure out to each side to within one inch (25 mm) of underarm seam.
4. Cut out front yoke sections and back neckline as shown in Figure 2. Machine zig-zag at least twice and finish edges (except back neckline) with blanket stitch. This will hide the sewing thread.

5. Cut out two leather yokes. With an awl, punch holes ¼ inch (6.4 mm) apart along edge and about ¼ inch in from the edges.
6. Cut out yoke facings using leather yokes as pattern. Zig-zag stitch raw edges.
7. Holding leather and facing pieces as one, blanket stitch all around using previously punched holes as guide.
8. Whipstitch yoke sections into sleeve-yoke section.
9. Cut out back neck facing using back neckline as guide. Finish raw edges with zig-zag stitch and attach to neckline by hand. Secure zig-zagged edge with blanket finishing stitch.
10. Join body to sleeve-yoke section with whipstitch from left front around to right front in one continuous seam.
11. Cover leather buttons and attach. Make braided leather strips and attach.

DOUBLE WOVEN REVERSIBLE JACKET

My need for inspiration one day led me to a local fabric shop. What better place to see the latest in fashion styles and colors, I thought. I started thumbing through the piles of pattern books. My fingers did the walking as I viewed the world of "haute couture". I wasn't looking for anything in particular—my purpose was more to saturate my brain with ideas in the hopes that something would germinate and grow. McCall's pattern #7310 was my seed. A quilted jacket that could be woven as a double weave. I quickly located the pattern and brought it to the cashier to purchase. Although I was planning on making a loom-shaped version, I wanted to take a closer look at the pattern for working out the details.

I knew from previous garment weaving experience and a few "bombs" that careful and methodical planning were the key to success. And this jacket in particular appeared to require lots of preplanning. First of all, the double weave would be formed into a series of weftway narrow tubes which could be stuffed on the loom as I went along. After filling, each tube could then be closed to secure the batts. I would work the tubes in three colors alternating as I went along.

Next, I worked out the weaving details on paper. First I had to decide the size of the tubes and the number needed to make up the jacket. I also had to determine the color sequence for the various sections which comprised the jacket so that the colors would integrate properly when assembled. (See Fig 1).

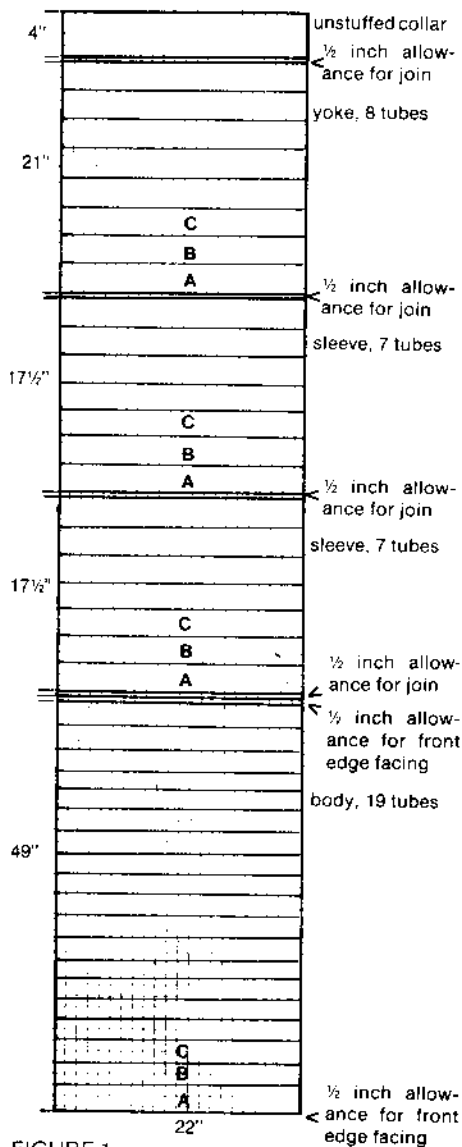
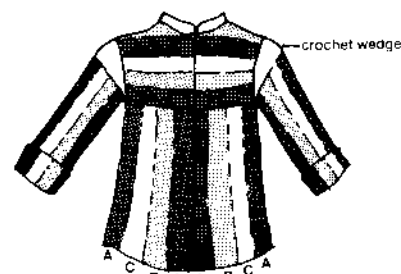

FIGURE 1

Since I wanted the bands of color to run vertically down the body but horizontally across the sleeves and yoke, I could see from my sketch that the yoke and sleeves would have to be woven in three sections. My loom was only 10 inches (102 cm) wide and I was going to need a piece of fabric that was

54 inches (137 cm) wide. Even with a wider loom I would have opted for this approach since it would not waste any of the warp.



I then proceeded to make a mock-up of the garment using muslin for fabric and two inch wide masking tape for thread. From the model, I could see that it was necessary to modify the loom-shaped version slightly by tapering the sleeves since they would be too bulky when stuffed.

Another planning detail also became evident from my muslin replica. Since the sleeve pieces would need to be seamed and cut, the band of color where this occurred would be reduced. I wanted color "A" to be the first horizontal stripe across the sleeve and yoke areas so I decided to add about two inches of fabric at the beginning and end of each sleeve piece to be used for construction purposes. By doing this, color "A" would be the first complete band occurring on the sleeve and could be aligned with color "A" on the yoke, thus forming a continuous stripe.

Now for some fun—planning the colors. For me, this is always the highlight of a project since I am a dyer. Any color I want is mine for the mixing. I knew I wanted to work with three weft

colors. But which ones? The possibilities were almost limitless. Going through my color samples, I found that I was continually drawn to the lavender and brown tones. So these became the shades around which my color scheme was based.

To add interest to the fabric I decided to combine three different fibers for each of the colors to be used. As a dyer this was no problem since I could color various fibers together in the same dyebath to produce a single color. Two warps, a light tone for the top surface and a dark shade for the bottom, were also dyed at this time to coordinate with the weft colors.

With the garment details worked out on paper and the yarns dyed it was time to proceed to the loom. The loom was set up for tubular double weave; see Fig. 2. The actual weaving process went quite smoothly as long as I kept my shuttles in order. Each tube was stuffed and closed as it was woven. To accomplish this a piece of 1/4 inch (6.1 mm) polyester batting was cut slightly smaller in both width and length than the tube it was to fill. I reasoned that the fabric would shrink when full while the batting would not. The batting was laid inside the tube and stretched to fill the space. The tube was then closed by weaving the two layers of fabric as one.

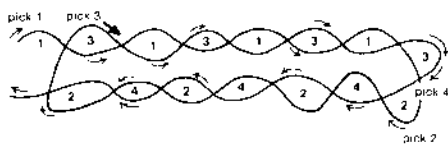
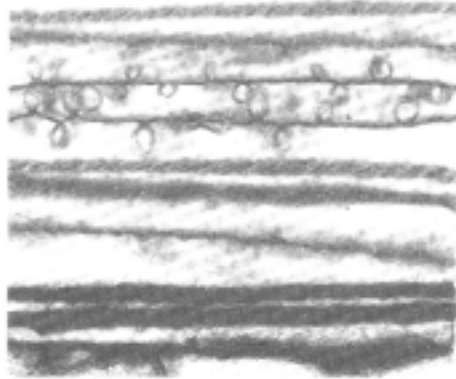

FIGURE 2

After completion of weaving the fabric was removed from the loom and the cut edges secured on the sewing machine—my one concession to using this contraption. The fabric was then full in the washing machine by agitating for six minutes on the gentle cycle. What was previously a web of woven threads was now an integrated piece of fabric.

This is as far as I take a garment. My loom and I have a beautiful working relationship but my sewing machine



is my nemesis. I take the project through the planning stages, dye the yarns, weave the fabric and then full it in the washing machine. Then Lynn Daly does her magic with the sewing machine. She works out the construction details and takes the piece of fabric and turns it into a beautiful garment.

To construct the jacket she first tapered the sleeves and yoke, making the jacket fit better across the shoulders. Inside seams were hand finished using a blanket stitch. Next, the sleeves were attached to the yoke with a crocheted gusset. The sleeve-yoke section was then secured on the inside of the body piece using a blanket stitch worked with one of the weft yarns.

The neck area and front opening in the yoke were then formed and the raw edges secured by zigzagging on the sewing machine at least twice and three times in areas of stress. The raw edges that occurred along the front of the jacket were turned under and caught with a blanket stitch to give a hand-finished look.



Next, the mandarin-style collar was shaped. I had woven an extra piece of fabric which was left unstuffed for this purpose. It was attached in much the same way as such collars are added on any jacket. The first step was done on the sewing machine for strength. The raw edge was then turned under on the inside and sewn by hand so there were no visible signs of machine sewing. With the collar attached, the garment was finished. What had begun as a tiny seed in my brain had matured into a successful, handwoven jacket.

WEAVING INSTRUCTIONS



WARP: 20 2 wool for both fabric layers. Warp for top layer dyed a shade of dark violet. The bottom layer warp was dyed a pale, grayed shade of violet.

WEFT:



Color A-lavender

- Mohair (Henry's Attic) 
- 2 ply wool mill end (Medium weight) 
- Boucle (Henry's Attic-Bubbles) used double on bobbin 

Color B-maroon

- Mohair (Henry's Attic) 
- 2 ply wool mill end (medium weight) 
- Tahki Donegal Tweed Homespun (commercially dyed a similar shade) 

Color C-beige with hint of violet

- Mohair (Henry's Attic) 
- 2 ply wool mill end 
- Tahki Donegal Tweed Homespun—light beige. Overdyed with color C 

LENGTH OF WARP: 155 inches (3.91 m)

SETT: 16 epi (60/10 cm) (8 epi fabric layer) sleyed 1,2,2 in a 6 dent reed. Warps for both fabric layers sleyed together through the reed.

WIDTH IN REED: 22 inches (58.7 cm)

TOTAL NUMBER OF ENDS: 176 top layer; 177 bottom layer

THREADING, TIE-UP AND TREADLING: see Fig. 3

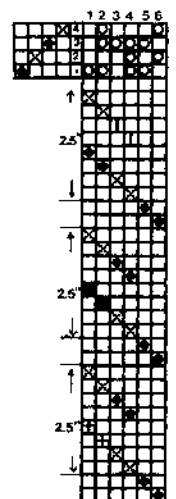

FIGURE 3

RAANU TUNIC

Powder blue, dark cinnamon, sage green, mellow gold. Small skeins of these and dozens of other colors spilled from the shelves and drawers of my weaving room. I had so many colors of yarn samples from my dyeing that I needed to use them soon or build an addition to the house.

Patterns of rug weaves learned in a workshop gave me an idea. The complex looks but simple weave structure of raanu would be ideal for combining many colors. Raanu originally referred to a thick, coarsely woven cover made by the Scandinavian Lapps and distinguished by color patterns of vertical and horizontal stripes which often told a story. Today it has come to mean a specific type of patterning. A particular raanu pattern is made by alternating contrasting colors in a pick and pick sequence. Many patterns can be obtained by simply altering the color order and the number of picks of a certain color (see Fig. 1). I decided to try this technique on a tunic using my dye color samples.

Because raanu is traditionally a rug and not a garment weave, it was necessary to adapt this weave structure to one that would be light enough to be comfortable as a garment and also drape attractively. To achieve this I used a tabby weave for solid color areas and a lightly packed basket weave for pattern sections (2 up, 2 down). Since some of the warp would show in the tabby areas, a neutral color was chosen to blend with the many weft shades. To offset the complex-looking raanu patterns, I decided to weave a basic loom-shaped style with a square neckline. A simple crochet finish would be used to hide the raw edges and further shape the tunic.

Not knowing the traditional interpretations of the various color sequences, I decided instead to choose a group of harmoniously related shades. Maybe my tunic would unintentionally tell a story or it might be fun to create my own. To see the actual colors of my skeins of yarns more clearly, I picked a bright, sunny day to make my color selections. Natural light is ideal for this purpose.



1. Alternate color A and B for desired amount.
Weave color A for desired amount.
Alternate color A and B for desired amount.
Weave color A for desired amount.
2. Weave 2 rows of color A.
Weave 2 rows of color B.
Repeat.
3. Alternate color A and B for desired amount.
Alternate color B and A for desired amount.
4. Weave desired amount of color A.
Alternate color A and B for desired amount.
Weave three rows of color A.
Weave alternating color A and B for desired amount.
Weave desired amount of color A.
5. Weave same as number 4,
substituting A for B, and B for A.

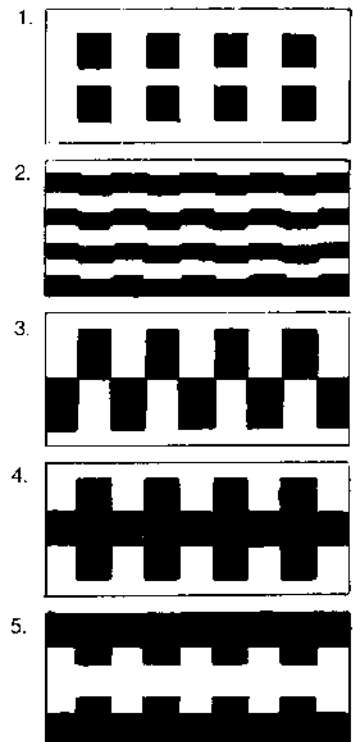

FIGURE 1

Boxes and baskets of yarns were carried outdoors to my front porch where many color combinations were tried before I finally settled upon those I wanted to work with. I ended up choosing twenty-two harmonious colors in shades of almond, tan, rust, mauve, violet, salmon and peach. The softness of the shades complemented each other and the finished tunic could be easily coordinated with many garments in my wardrobe.

As I started weaving, however, I found that the color order I had painstakingly worked out would have to be altered. Two skeins of yarn side by side did not always appear as expected when woven. In some cases the color values were too similar and the pattern was lost. In other instances another color combination worked better for a particular pattern sequence.

The pattern and color decisions that had to be made as the weaving progressed kept the slow process from becoming tedious. The freedom of being able to create as I wove made this raanu tunic a most satisfying project.

It also was a valuable lesson in working with various color combinations.

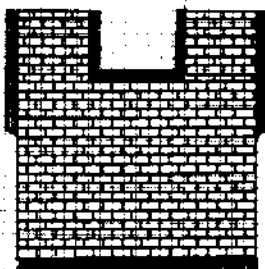

FIGURE 2

WEAVING INSTRUCTIONS

WARP: 20/2 wool

WEFT: 2 ply wool mill end, medium weight dyed many shades of harmonious colors. Commercially dyed yarns left from various projects can also be used but avoid combining many textures. Color is the focal point.

LENGTH OF WARP: 78 inches (1.98 m)

SETT: 8 epi (30/10 cm) sleyed 2,1,1 in a 6 dent reed

WIDTH: 20 inches (53 cm)

TOTAL NUMBER OF ENDS: 160

THREADING, TIE-UP AND TREADLING: see Fig. 3

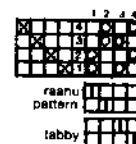

FIGURE 3

CONSTRUCTION OF GARMENT: see Fig. 4

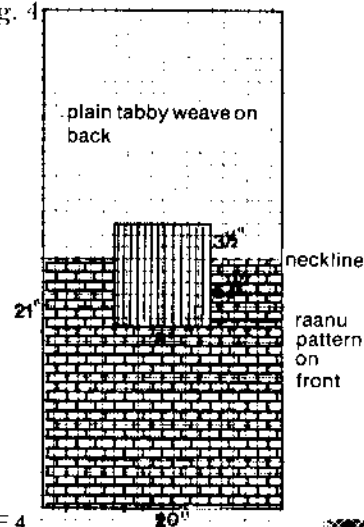

FIGURE 4

BABY BEAR

BABY BEAR

100% COTTON
Natural, unscoured
Approx. 900 yds./lb.

Direct Inquiries—Wholesale Only
or inquire
at your favorite weaving shop

HENRY'S ATTIC
TEXTURED WEFT YARNS
5 Mercury Avenue
Monroe, NY 10950
914-783-3930

Send \$7.50 for
Complete Sample Set

WHITE SPACE

Really works. Call (303) 449-1170 for information on advertising. Need help? We can design your ad for you.
GRAPHICS, P.O. Box 2049, Boulder, CO, 80306

154 Mary Alexander Court, Northville, MI 48187 (313) 349-7509



A



B

TEXTURED COTTONS

Weavers are familiar with smooth cottons such as 20/2 which, sett at 30 epi, is the standard warp for colonial coverlets; or 10/2 which is often used for table linens; or 8/4, which is the standard size for carpet warp; or 5/2, the popular size for perle cotton. These smooth yarns have varying lusters depending on the length of staple, on the chemical processes applied to the fiber and on the spinning processes. What about textured cottons? Among textured blends and/or pure cottons we have selected a textured 100% cotton marketed by Henry's Attic (NY) called **Monte Carlo** for this study of cloth structure and clothing patterns. It is a "fancy" yarn in which fluffy cotton fibers are spun around a 2-ply cotton core. This strand is then plied with a thin cotton single. The yarn is beautiful to look at and very pleasant to the touch. It works both as warp and weft as well as for knitting. But be aware! There is a lot of shrinkage in the wash and the yarn is too delicate to withstand repeated full cycle washing and drying. Handwashing is advised.

Several weavers have contributed to this issue of *The Weaver's Journal* projects which were done with Monte Carlo. Peg Rasmussen (Glen Ellyn,

IL.) used the yarn exclusively in her "no seam tubular shirt". Sue Henriksen (Boulder, CO) mixed it with rayon for a stylish and comfortable long sleeved dress and replaced the rayon with cotton, Cottolin and Linay for a sauna robe. At the studio of the Colorado Fiber Center we experimented with a long warp set up on a 12-shaft loom to combine the following three studies:

1. Using a 12-shaft straight draw threading, what interesting 12-shaft, 10-shaft, 8-shaft, 6-shaft, 4-shaft, and 2-shaft weave structures can one get just by changing the tie-up and readling?
2. What successful and economical

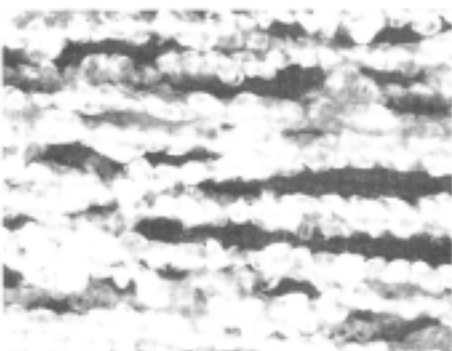

*Monte Carlo is now marketed as Monte Cristo.

(minimal waste, minimal sewing) projects can be made from a long narrow piece of yardage.

3. How does a change of weft affect the fabric?

D





C

HOW TO GET THE MOST FROM ONE WARP

WARP: Monte Carlo (textured 100% cotton) (●).

2 ply cotton, about size 10/2 with

slight texture or slub (x). Rayon or silk or blends may be substituted.

TOTAL NUMBER OF ● x PAIRS: 160.

WARP ORDER: x ● ● xx ● ● xx ● ● x, sleyed in an 8 dent reed as follows:

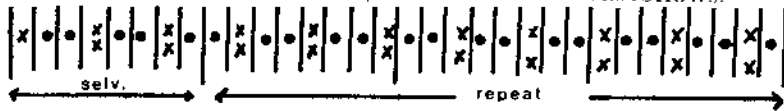

E



F



WIDTH IN THE REED: 30" (76 cm).

THREADING, TIE-UP AND TREADING:

There are 5 different weave structures, numbered 1 through 5. They can all be woven on the same warp threaded on a 12-shaft loom but they can also be woven on fewer shafts. Chart 1 gives the threading, tie-up and treading for looms from 2 to 12 shafts. Choose the appropriate one. The number given next to the tie-up refers to the sample shown in the accompanying photograph.

WEAVING: Whenever the same yarn goes twice through the same shed, use two shuttles and enter the shed from opposite sides.

x 2 ply cotton

● Monte Carlo

⊗ 2 ply cotton together with fine lurex.

FINISHING: All fabric was machine washed and dried before making it into garments. Count on 15% to 20% shrinkage. Samples 1, 2 and 3 in which Monte Carlo was used both in the warp and in the weft shrank to a thick spongy fabric.

G



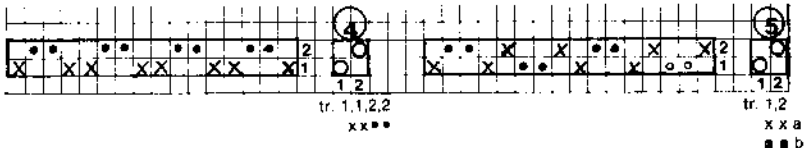
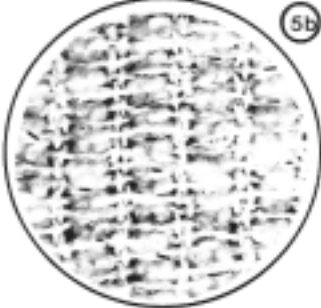
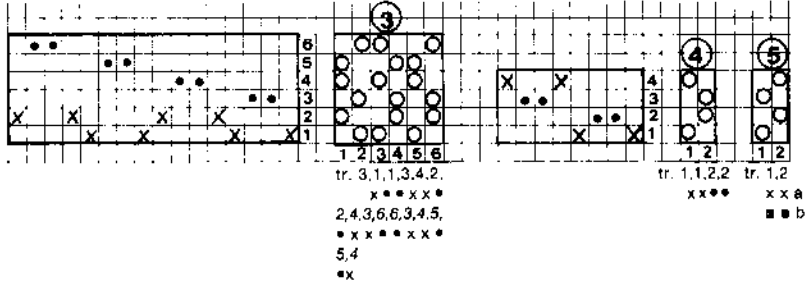
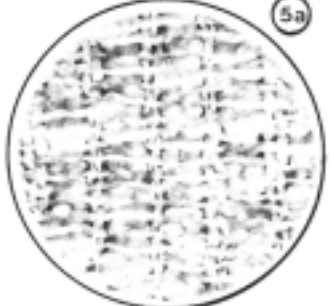
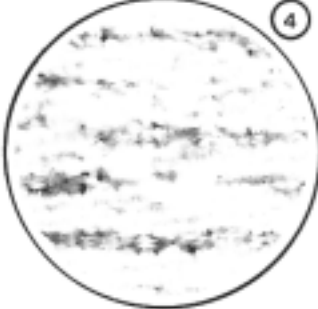
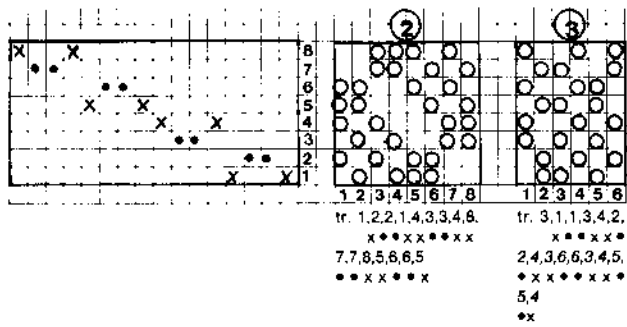
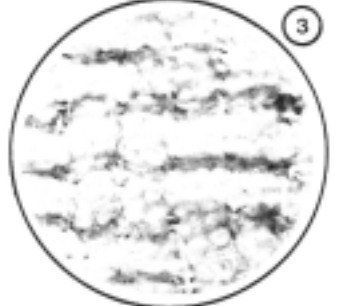
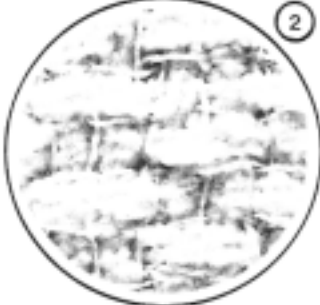
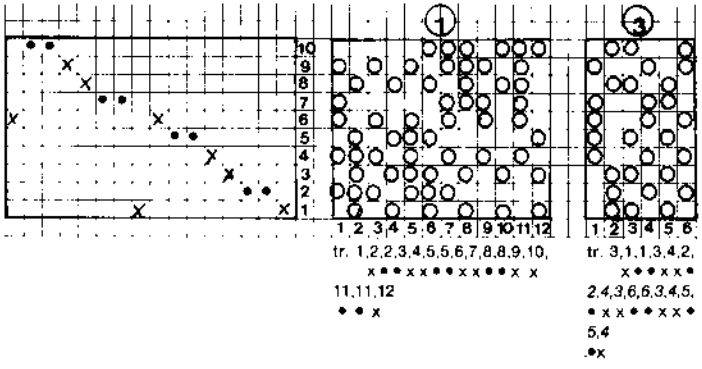
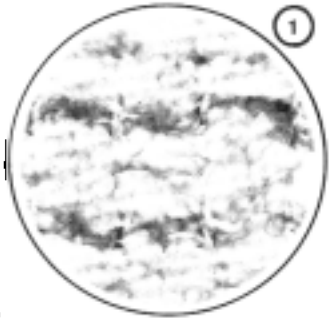
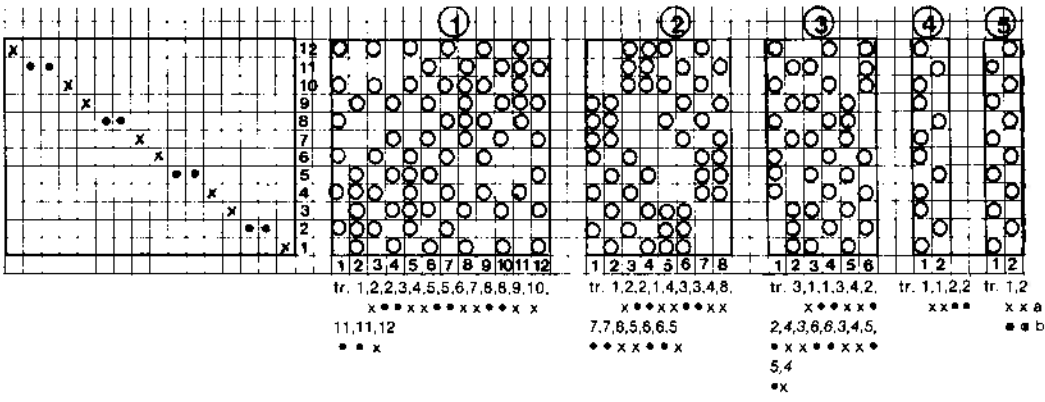
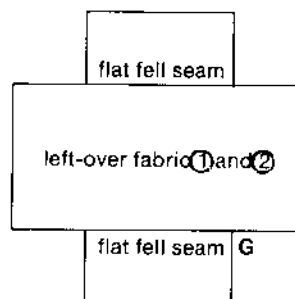
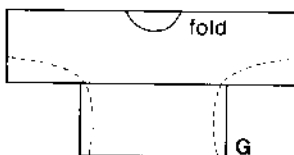
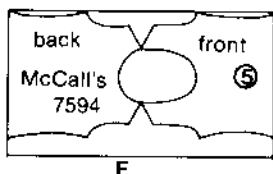
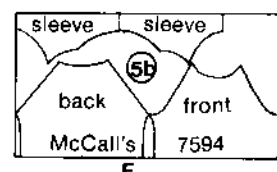
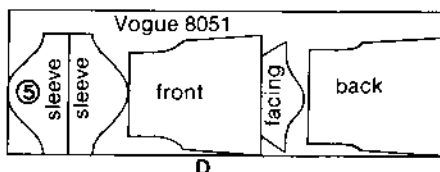
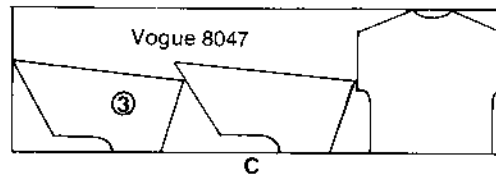
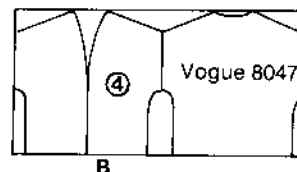
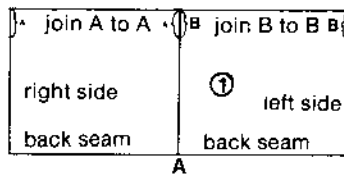

CHART 1

PATTERNS AND LAYOUT

For the blouses and tops commercial patterns were used as guidelines. Vogue 8047 for B and C, Vogue 8051 for D, McCall 7594 for E and F. All the cutting lines were machine sewn to guard against unravelling. All the seams are flat felled seams except for the shrug A in which the backseam is sewn by hand. All the hems (sleeves and bottom) as well as the necklines were reinforced with machine stitching, folded $\frac{1}{4}$ " (6.4 mm) and finished with crochet. The waistband of blouse F was knitted. For the knitting or crochet, use Monte Carlo or the thin cotton used threefold.



Patterns and layout

seam allowances are included



The Weaver's Loft

for your weaving and spinning needs.

• Schacht (at discount) • Norwood • Harrisville •

Unique fashion threads
for knitting and crochet

Open Monday-Thursday, 11-5; Friday 11-7; Saturday 9-5

(815) 786-2233

215 West Center, Sandwich, IL, 60548



**TWILLS and
TWILL DERIVATIVES**
Lucille Landis (2nd printing)

No need to depend on recipes for your twills! Use a logical approach to understand their construction, then design YOUR OWN four to eight harness fancy, braided, interlocking, corkscrew, decorated, and waving twills, or crepes, waffles, and shadow weaves.

150 B&W photos, nearly 300 patterns, 120 pages, soft cover, \$10.50. Add 7½% Sales Tax in Conn. Postage \$1.50 per copy, \$.35 add. copy. Dealer inquiries invited.

Book Barn, Box 256, Avon, CT 06001

SUMMER WORKSHOPS '82 FIBERS/PAPERMAKING



call or write for brochure

ANDERSON RANCH ARTS CENTER
BOX 2410 ASPEN, COLORADO 81612 (303) 923-3181

RACHEL BROWN
YOSHIKO WADA
MARIE LYMAN
SYLVIA SEVENTY
JOYCE AKIN
SAS COLBY
ANDE LAU CHEN
WALTER NOTTINGHAM
BERNIE VINZANI
TWINROCKER
SUZANNE ANKER



DRESS AND SAUNA ROBE

contributed by Sue Henrikson.

WARP:

- Monte Carlo (textured 100% cotton)
- x For dress: Rayon, used twofold
- For robe: Cottolin (rust), Metallic, Linnay (rust).

WARP ORDER: (●●●●● x x x) repeat, sleyed in a 4 dent reed as follows:

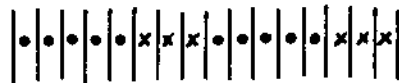

Two warp beams were used. ● warp under loose tension, x warp under tight tension.

WEFT: x For dress
Cotton for robe (white).

WIDTH IN THE REED: 42" (107 cm).

WEAVE STRUCTURE: Plain weave.

FINISHING: Machine wash and dry. Allow for 20% shrinkage when you calculate the length and the width of the warp. All edges were triple stitched as soon as they were cut.

Patterns

DRESS: Vogue pattern 7746 was used as a guideline. No facing was used. The cuffs, hem and neckline were crocheted with rayon.

ROBE: Vogue pattern 9616 was used as a guideline. All seams are flat felled. All edges crocheted with cotton.

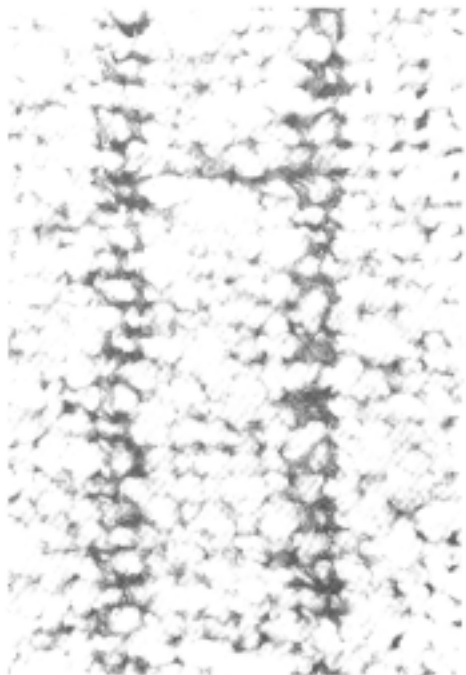

Detail of sauna robe fabric



SEAMLESS, NO-SWEAT SHIRT

by Peg Rasmussen

Here's the perfect project for the weaver who hates to sew! Once the loom is warped, the shirt can be woven in record time, coming from the loom virtually ready-to-wear. Because of unique loom-shaping (no side seams and no shoulder seams), the warping process takes a bit longer than usual, and close attention must go to each step.

My choice for warp and weft was Monte Carlo cotton from Henry's Attic. Soft, pliable yarns of cotton, rayon and silk seem most suitable. The slubs in a textured yarn will conceal

the transitions from front to back in the tubular weave. In this piece the shoulder magically appears when the apron rod is withdrawn!

This project requires a 4-shaft loom about 30 inches (76 cm) wide. Children's sizes could be made on smaller looms. A 3-yard (2.75 m) warp will be enough unless the loom allowance is unusual. Determine the number of ends per inch and the width required for one layer (allowing for shrinkage). See Fig. 1. Multiply the inches in width by the ends per inch, but *do not double* the result even though you will be weaving 2 layers from one warp. In making the 3-yard warp on the warping board, use care to keep it free from knots. If a knot must be made, tie it at the end of the warp with the "cross." Secure the cross and chain the warp as usual.

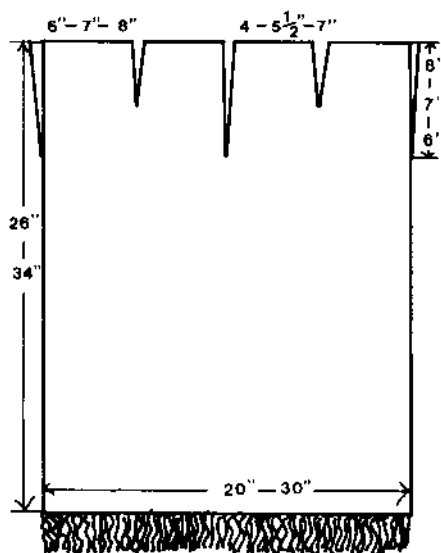

FIGURE 1

Insert 2 lease sticks at the cross and tape them to the breast beam. See Fig. 2. Cut across the upper loop of the warp chain. If you want the fabric to have 10 epi, use a 10 dent reed; 8 epi, use an 8 dent reed, etc. Sley the reed from the cross using only *one* warp thread to each dent.

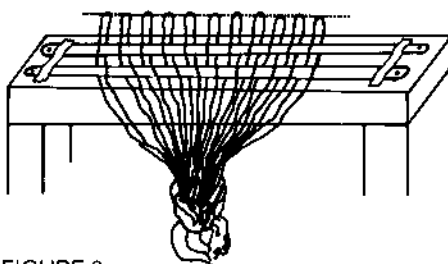

FIGURE 2

Thread the first warp end through a heddle on the front shaft 1. Leave an empty heddle in position on the second shaft 2. Thread the second warp end through a heddle on the third shaft 3. Leave an empty heddle in position on the fourth shaft 4. See Fig. 3. Repeat. When all the warp has been threaded onto shafts 1 and 3, with empty heddles in position on shafts 2 and 4, tape the ends to a stick held behind the shafts.

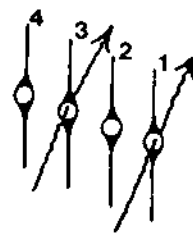

FIGURE 3

Release the chained warp and draw the stick with the taped ends toward the back of the loom. This can be secured to the back beam temporarily. At the front of the loom insert a stick in the loop at the end of the warp, which is now unchained. Cut across the loops so all ends are the same length. Remove the stick.

Sley the first newly-cut warp end through the reed in the *same* dent used previously. Thread through the empty heddle on shaft 2. Pair this end with the first taped end from shaft 1, tying them to the warp beam rod in back. Take the next unsleyed end through the second dent, through the empty heddle on shaft 4, and secure it with the taped end from shaft 3. See Fig. 4. Complete slewing, threading and pairing ends in this manner until all are tied to the warp beam.

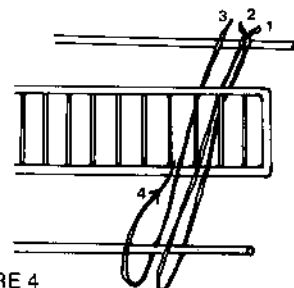

FIGURE 4

Begin slowly to wind the warp onto the warp beam. When the last of the warp reaches the lease sticks, insert a 1/4" (6.4 mm) metal apron rod through each loop newly formed at the front of

the loom. Then remove the 2 lease sticks. Even up loose warp threads by adjusting and retying the pairs at the *warp beam*. Finish winding the warp. Stop when the apron rod reaches the reed.

Lash the apron rod with a strong, *fine* cord to another rod or stick in the apron of the cloth beam. See Fig. 5. The apron must reach almost as far as the reed. When you are sure the tension is uniform, weaving begins.

To weave a shirt with shoulder and neck slits use 8 small shuttles (belt shuttles are a good choice).

Shaft 1 up. With 4 shuttles weave 4 sections from right to left (upper layer).

Shafts 1-2-3 up. With 4 more shuttles weave 4 sections from left to right (lower layer).

Shaft 3 up. Weave upper layer sections from left to right.

Shafts 1-3-4 up. Weave lower layer sections from right to left.

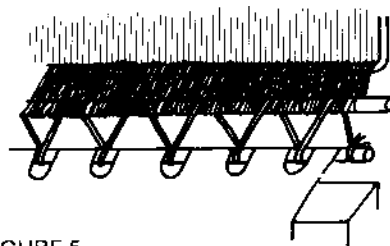

FIGURE 5

Beat the first few rows extra tightly against the apron rod. Be careful not to lock upper and lower layers. Check occasionally by raising shafts 1-3 to be sure of separation.

Continue weaving until shoulder slits measure 2½ or 3 inches from the rod. Terminate the shoulder slits by using only 2 shuttles on the top layer and 2 on the lower layer. Terminate the neck opening when it measures 6-7 or 8 inches (15-18 or 20 cm) from the rod. At this point substitute one boat shuttle for the many belt shuttles and work in the round to construct the tubular body and close the armholes.

Shaft 1 up from right to left.

Shafts 1-2-3 up from left to right.

Shaft 3 up from right to left.

Shafts 1-3-4 up from left to right.

Continue until shirt measures 26 inches (66 cm) or desired length, allowing for shrinkage. Separate the layers (raise shafts 1-3). Cut and secure warp ends across the upper layer, then across the lower layer. I braided the ends, then interlaced them and knotted the tails.

Withdraw the apron rod, ease weft rows into place forming (Voilà!) the seamless shoulder. The slits are reinforced by darning in the tail ends of weft. Crocheted edges can be worked around openings with the weft yarn.

Many variations are possible with this shirt—hems, fringes, casings for elastic, gathered “sleeves,” shaped necklines, stripes, decorative slits filled with needlelace or crochet. It could be a dressy evening top, beach cover-up, shell blouse, night-shirt or tunic according to your design details and yarn choice. Best of all—there’s no sewing!

FOLKLORICS!

Native American Inspiration

LONG SWEEPING EVENING CAPE

by Bettie G. Roth

When one thinks of loom controlled clothing one immediately envisions a garment created with rectangles, squares, neck slits, and fringes. However, another approach to loom controlled garments is in the control and placement of a pattern. Such was the technique used in creating the *Kachina Doll* cape.

These figures, which are laid-in on a plain weave ground, could be woven on a two or four shaft loom using the Dukagang pick-up technique but here the extra shafts of a 10-shaft loom were put to use to avoid most of the pick-up work. The threading draft is that of Summer and Winter.

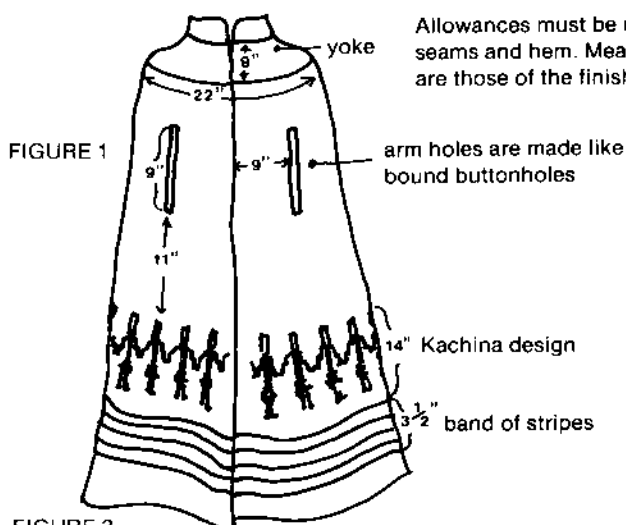

FIGURE 1

Allowances must be made for the seams and hem. Measurements given are those of the finished garment.

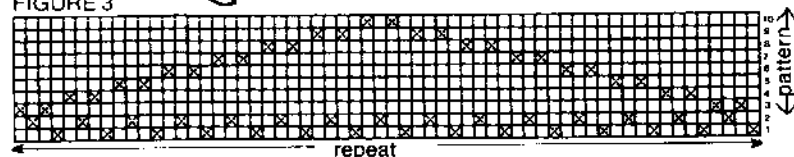

FIGURE 3

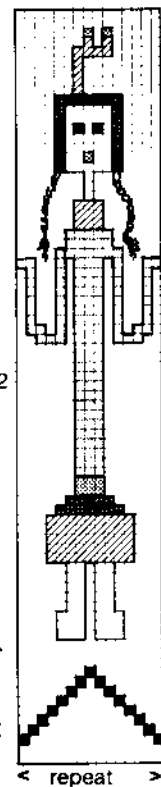

FIGURE 2



photo by John Webber

Three panels of yardage were woven with the design of Kachina Dolls strategically placed on the fabric. The garment was assembled with the sections attached to the yoke to permit the panels to hang straight. This gave the cape a graceful flow and kept the pattern straight across the bottom. The armholes were cut and finished as one would do bound button-holes. The cape was lined in a contrasting color picking up the turquoise used in the pattern.

WARP: Two finely textured acrylic yarns.

WEFT:

Ground or tabby weft—same as warp.
Stripes and inlay—a yarn twice the grist of the background thread in red, lt. brown, dk. brown, purple, turquoise and flesh.

SETT: 20 epi (80/10 cm).

WIDTH IN THE REED: 30" (76 cm).

LENGTH: Three floorlength panels.

BLOCK DESIGN AND PROFILE.

DRAFT: See Fig. 2.

Note that the profile draft does not fit the headdress correctly. Adjustment

will have to be made by means of pick-up to weave that section of the design.

THREAD BY THREAD DRAFT: See Fig. 3.

TREADLING: For the ground, weave tabby by alternating shafts 1+2 and shafts 3+4+5+6+7+8+9+10.

For the figures, alternate a tabby pick and a pattern pick. For the pattern pick use separate butterflies for each figure, thus omitting long floating threads on the reverse of the fabric. For each pattern pick lift shaft 1 and the pattern shafts of the background and insert the butterfly through the warp and let it dangle underneath until the next pattern pick has to be woven. (That is, unless one chooses to weave the cloth wrong side up). For example, to weave the feet of the doll, lift shaft 1 and the pattern shafts of the background, which are 3, 4, 5, 6 and 10, and insert the flesh colored butterfly from toe to toe. Repeat 12 times (4 times per square) always remembering to alternate with a pick of tabby.

The handmade necklace worn over the cape is a series of varied size rings covered with yarn in a buttonhole stitch. They are linked together by sewing. The colors in the necklace are the same as those found in the Kachina Dolls and add more color and design to the total garment.

Bettie G. Roth is a member of the Sacramento Weavers Guild; Handweavers Guild of America; Chairman of the American River College Textile Library Committee, Sacramento, California; and Chairman of Art Gallery Weaving Exhibits for the Conference of Northern California Handweavers 1982. She has had articles published in Handweaver and Craftsman and Shuttle, Spindle and Dyepot. Bettie lectures and gives workshops on a variety of subjects pertaining to weaving.

YARN COUNT SYSTEMS

YARN COUNT SYSTEMS (OLD COUNT)			
Yarn count systems give the linear density of a given yarn.			
YARN COUNTS FOR #1 YARN: LENGTH PER UNIT WEIGHT OF A SINGLE YARN.			
FIBER	YARDS/lb	YARDS/kg	METERS/kg
Cotton			
British	840	1852	1693
Continental	992	2187	2000
Linen			
(wet spun) lea	300	661	604
Silk			
spun	840	1852	1693
Woolen			
American cut	300	661	604
American run	1600	3528	3226
Dewsbury	16	35	32
Galashiels cut	200	441	403
W. of England hank	320	705	645
Yorkshire skein	256	565	516
Worsted	560	1235	1129

Yarn counts for other numbered yarns: multiply the number by the factor given in the chart. EXAMPLE: 8 worsted will yield 8 x 560 yards per lb.

Plyed yarns: the length per unit weight is found by dividing the count of the yarn by the ply. EXAMPLE: 2/8 worsted will yield 8 x 560 yds. ÷ 2

Note: Woolen and worsted spinners usually show the ply first, followed by the count number. Cotton spinners often show the count number first, followed by the ply (8/2). To be sure, count the number of singles in a yarn.

chart 1

TEX SYSTEM	
The Tex System gives the weight per unit length, i.e. the weight in grams of 1 km (1000 meters) of yarn. EXAMPLE: Tex 10 yarn means 1 km of that yarn weights 10 g.	
CONVERSION FROM YARN COUNT SYSTEM TO TEX SYSTEM	
FIBER	For tex system, divide number in this column by old count number
Cotton	
British	590.541
Linen	
(wet spun)	1653.52
Silk	
spun	590.541
Woolen	
American cut	1654
American run	310
Galashiels cut	2480
W. of England	1550
Yorkshire skein	1938
Worsted	885.812

EXAMPLE: Tex number = $\frac{310}{\text{woolen run count \#}}$
 Tex number = $\frac{590.451}{\text{silk count \#}}$

Plyed yarns: they may be expressed as the singles count and the ply. EXAMPLE: Tex 20 x 2 yarn consists of two singles each weighting 20 grams per km plyed together with a resulting count of Tex 40 yarn.

chart 2

METRIC CONVERSION TABLE	
1 yard	= 0.9144 meters
1 meter	= 39.37 inches
1 pound	= 0.453592 Kg.
1 kilogram	= 2.205 pounds (2 lbs 3 oz)

What do the numbers 2 8 worsted really mean? It gives the size and ply of the yarn and through a quick calculation it should give you, for instance, the number of pounds of yarns to buy for a certain length warp. This is the *indirect* yarn count system for a 2 ply 8 count yarn.

With the help of Chart 1, you can find the *standard length* for various fibers; a #1 count worsted yarn has 560 yards/lb.

A number 8 count worsted yarn has 8 x 560 yds./lb.

A 2/8 worsted has $\frac{8 \times 560}{2}$ yards/lb and is two-plyed.

If one needs 1500 yards of warp yarn (2/8 worsted), one should purchase $\frac{2 \times 1500}{8 \times 560}$ lbs.

$$\frac{\text{Ply} \times \text{length in yards needed}}{\text{count} \times \text{standard length}} = \text{weight in lbs.}$$

From Chart 1, one can see that the standard lengths vary from one fiber to the other and are not even universal for one single fiber (woolen). Therefore a new system, the Tex system, will gradually become more and more in use.

Chart 2 shows the conversion from the old yarn count system (indirect system) to the Tex system (direct system).

To convert from indirect system to Tex system, use the following formula:

$$\text{Tex count} = \frac{\text{conversion factor}}{\text{indirect count}}$$

To convert from Tex to indirect count

$$\text{Indirect count} = \frac{\text{conversion factor}}{\text{Tex count}}$$

Use Chart 2 for the conversion factor.

If you need 1500 m of warp yarn "2 ply Tex 40" you should purchase $\frac{2 \times 1500 \times 40}{1000}$ kg.

$$\frac{\text{Ply} \times \text{length in m}}{1000} \times \text{Tex count} = \text{weight in kg}$$

WEAVING AS A PROFESSIONAL

Production Weaving/Designing

by Janet Checker

You know how to weave; you enjoy the process and the feeling of accomplishment when you complete a project. Now what? If you sincerely want weaving to be more than a hobby, you must look at what you are doing in a new way. Two things will concern you, regardless of what the project is: they are *time* and *materials*. "Time is money," to coin a phrase, and the same can be said about yarn left lying on the studio floor when a project has been completed.

If asked the single most important way to save on both time and materials, I would have to answer: *planning*. From the planning of what you are going to do, to how much yarn will be needed to complete the entire weaving (warp and weft).

The most obvious first step is to plan yardage for several garments on one warp, thereby cutting down your time spent dressing the loom. By using one weft yarn for the entire project you save time in the actual weaving process.

When planning your yardage you will have to decide the maximum width you will need for your project; The measurement across the shoulder, chest or hips. For length, you will have to decide on how long the garment will be, usually from the neck bone to the longest point for a blouse or a jacket. Will there be sleeves, and how long? Will they finish off with a cuff or be turned under with a hem. To all this you add seam allowance, hem allowance and, of course, shrinkage and waste. Left over yarn should be saved. It can be used for rya knots, fringe, hat pom-poms or even pillow stuffing for future projects.

Another possibility is that instead of doing just a series of identical garments, you may design several co-

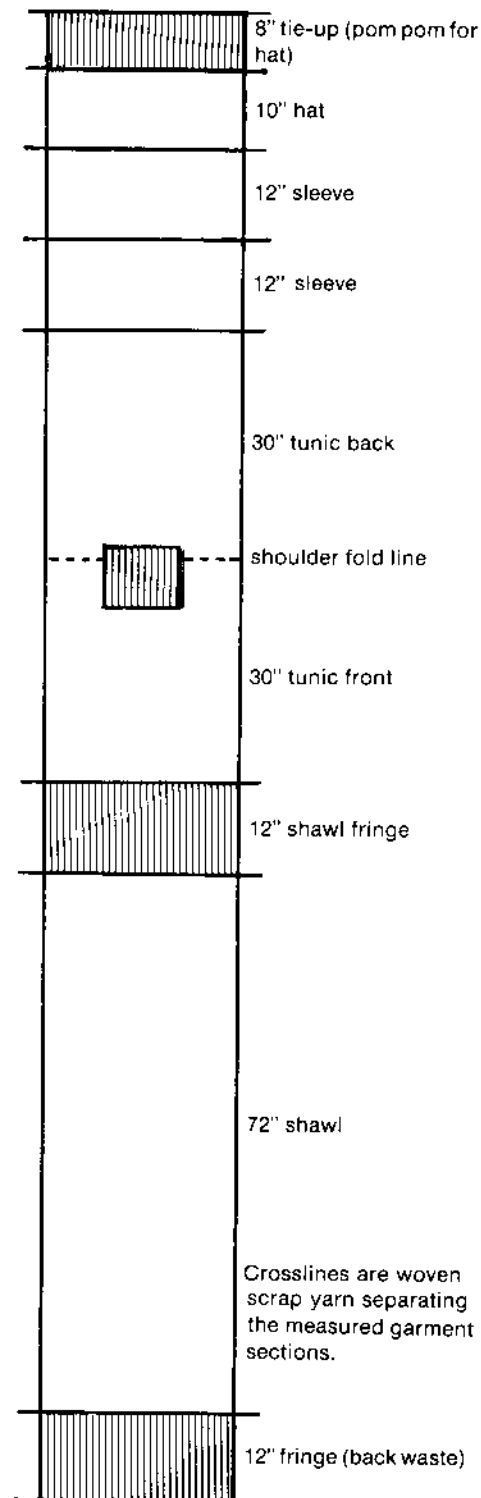

5 yards = 210 inches, project adds up to 198 inches, giving a total loss of less than 12".

ordinated items. As an example, using a 24" (61 cm) weaving width and a five yard (4.6 m) warp, you start with a hat, go on to a tunic with sleeves and end with a shawl. The waste yarn (for tie on) at the beginning is used for the pom-pom on the hat, and as for the waste on the other side, some of it can be used as fringe on one side of the shawl. In planning multiple projects for your warp, you must be careful that the weaving width can be used for all the projects.

The simplest and fastest thing to do is to just weave straight yardage but this can become monotonous if you have a long warp. Instead try designing as you weave. Using a tunic top for example, measure and mark each section, (front, back, sleeves) of the garment as you weave, adding any special woven detail as you go. Using two shuttles, weave the neck opening. It will be more fun knowing exactly what you have accomplished in a certain amount of time and it eliminates this step after you remove your cloth from the loom. Should you decide to design as you go, be sure that your measurements are accurate; a mistake here could be costly. An advantage to weaving this way is that you can change weft yarns on each garment, thereby creating different colors and textures for each. This gives you a versatile selection of clothing without the additional time needed to rewarp the loom for each garment.

I have tried to present you with a few ideas that have proved helpful to me. Although they may seem obvious to some, I have found in giving lectures that many obvious points can be overlooked. If I have persuaded you to give serious thought (planning) to a project before you start dressing your loom, then I feel I have been successful.

© Janet Checker



RAGS TO RICHES

RAGSTRIP VEST

contributed by Pam Scheirman

This vest was made of velveteen strips $\frac{1}{2}$ " (6.4 mm) wide and woven in tabby with a cotton warp:

WARP: 12/2 cotton (red)

WEFT: Velveteen strips (red)

SETT: 9 epi (40/10 cm)

WIDTH IN THE REED: 12" (27 cm)

My first attempts at weaving this fabric were spent trying to keep the velveteen side up so as to have a very soft-to-touch fabric. This was very time consuming and I soon decided to let the strips turn at will and ended up with a texture and color variation that I liked. The fabric was woven 12" (30 cm) wide and 3 yards (2.71 m) long. It was cut into two pieces of equal length and shaped as in Fig. 1.

I lined the vest to give it more body. The lining fabric is almost the same color as the vest. I made a twisted trim and outlined the entire vest leaving extra pieces at the neck opening as a tie.

© Pamela Scheirman

HONEYCOMB BOLERO-STYLE VEST

contributed by Phyllis K. Barrett

This vest woven with honeycomb pattern is made with 3 pattern pieces (Fig. 2). Each piece is lined separately by sewing it to the lining with the right sides together and leaving an opening to turn the piece inside out. The opening is closed with a slip stitch. The shoulders and side seams are subsequently crocheted together using the same 5/2 blue perle cotton as for the warp.

WARP: 5/2 blue perle cotton

WEFT: For the cells: 5/2 natural perle cotton.

For the outlining weft: a rather heavy cotton knit cut in $\frac{3}{8}$ " to $\frac{1}{2}$ " (9.5 to 12.5 mm) wide strips. These are laid in the tabby shed carefully and loosely in the hope that there will not be too much pull.

SETT: 12 epi (50/10 cm).

WIDTH IN THE REED: 20" (51 cm).

THREADING, TIE-UP AND TREADLING: See Fig. 3.

LENGTH: 2 yards (1.82 m).

FINISHING: Regular machine wash and dry.

Note: The weft tends to pull in and causes a 10 to 15% weftwise takeup plus shrinkage.

The overlapping ends of the knit strips are pushed back and can be tacked down with a few sewing stitches.



*Facing, left.
Ragstrip vest by Pam
Scheirman*

*Facing, right.
Honeycomb bolero-style
vest by Phyllis K. Barrett*

*Right.
Jacket from rags by Britta
Brones*

JACKET FROM RAGS

(or more truthfully, from new fabric)

contributed by Britta Brones

Growing up in Sweden, I remember rag rugs in almost every home. A summertime chore was to help mother cut up old clothes into strips. These were sent off to a weaver and came back transformed into rag rugs. As an everyday textile, they were just there, never thought of as especially exciting. But when, later in life, I saw Finnish rag rugs in a store, woven from new fabric in wonderful, coordinated colors, I fell deeply in love with them.

I moved to the U.S., started weaving and decided last year to incorporate three special interests of mine into one woven item: rags and colors in a garment. The result was this jacket, woven on a 25" table loom.

WEFT: Fabric strips, cotton and cotton/linen.

Novelty yarns in matching colors.

WARP: 3/2 cotton carpet warp

SETT: 12 epi (50/10 cm)

WIDTH IN THE REED: 24" (58 cm)

LENGTH OF THE WARP: approx.
4 1/3 yards (4 m)

THREADING: Rosepath

TREADLING: plain weave for ragstrips; twill for the yarn picks.

SHRINKAGE: about 15%

EXTRA: Purchased fabric (corduroy) for collar, front and bottom bands, over raglan sleeves and sleeve hemlines. Fusible interfacing for the bands, if needed.

FABRICS: If using all new fabric, as I did, I suggest buying lightweight broadcloth or batiste. Cotton/polyester blend is best, either 50/50 or up to 70% polyester and 30% cotton. Lightweight 100% cotton is all right too, but it makes for a heavier fabric and takes forever to dry. My choice was to use

solid colors, but a little texture in the weave doesn't matter. Remember though, that the tighter the weave, the better! Strips of loosely woven material tend to fray, even after they are woven.

HOW TO CUT AND USE THE RAG

STRIPS: Fold the fabric double and then double again. Cut straight across, not diagonally, through all layers. This gives you strips as long as the fabric is wide. Cut them, at the most, 5-8" (1.5 cm) wide. My Swedish weaving book suggests never to cut them wider. To weave heavier cloth, like rugs, use strips double in the shed, so that they pack down and cover better. Taper the ends of the strips. When you weave, overlap the ends about 1" (2.5 cm) when you change. I do all color changes at the selvages so the color lines are defined. If you don't want that, and are ambitious, you can machine stitch several strips together for a continuous strip.

JACKET PATTERN: A raglan cut makes the stripes an interesting part of the design. A commercial pattern was not used for my jacket, but you can buy one for a raglan jacket and use only the sleeves and upper bodice parts. Pin and zig zag *before* you cut, since the rags tend to "unweave" themselves quickly . . .

WEAVING: Hang the strips by color, close to the loom, so you can see what you have to work with. I create as I go, usually starting at the end of the color spectrum and then going down the line of colors available, using different amounts of each color. Shots of cotton and cotton/linen novelty yarns are inserted at random. They are treadled in rosepath, to achieve floats as extra texture. Remember to weave a seam allowance with carpet warp at the side of each piece.

FABRIC FINISHING: After it is off the loom, zig zag at the future seams and cut into the main pieces. Machine wash in warm water, regular cycle, and dry in a HOT dryer. This last step is very important because it shrinks, fulls and softens the material so the garment won't feel like armour . . . it also gives the surface a velvety appearance.

1 square = 1 inch

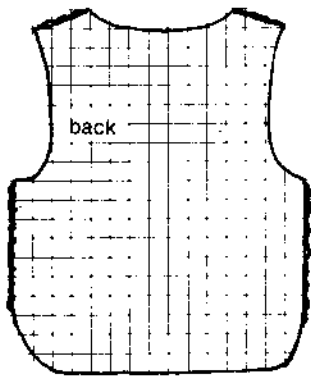

size 8-10

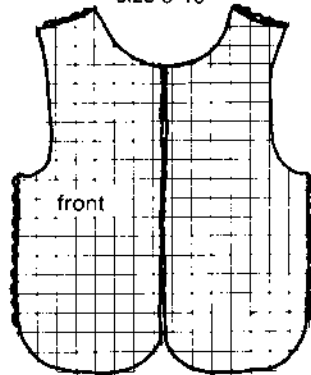

seam allowance not included

FIGURE 2 honeycomb vest

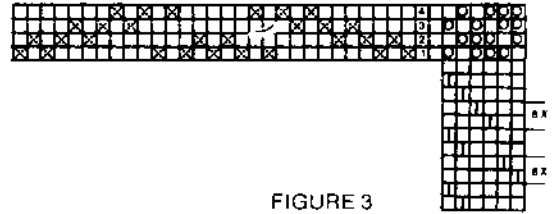
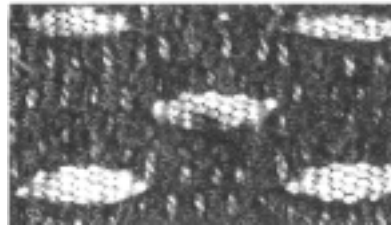

FIGURE 3

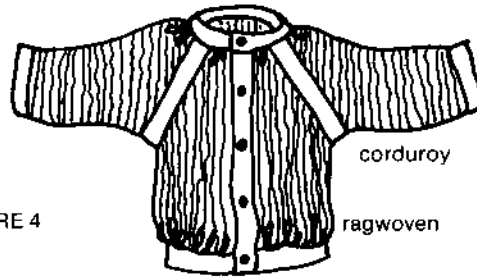
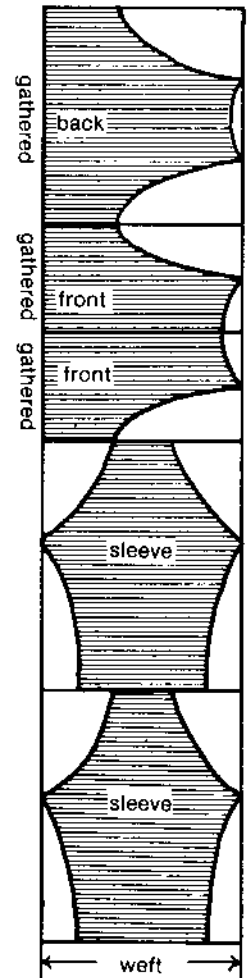

FIGURE 4

DIRECTIONS FOR ASSEMBLING JACKET:

- Measurements given below do not include seam allowance.
1. Use pattern for raglan parts (armhole of sleeve, fronts and back)
 2. Slightly taper sleeves (zig zag before you cut.)
 3. Cut out a crescent 1" (2.5 cm) wide at the front and back necklines for a better fit.
 4. Attach raglan sleeve seams to armhole edges of front and back. This is done with wrong sides together, so your raw seams are in the outside, to be covered later (see step 6). Press open the seams and machine stitch the allowance to the garment for a smoother end result.
 5. Sew fronts to back at side and sleeve edges in one continuous seam, which is pressed open and tacked down by hand.
 6. Cover raglan seams with fabric strips cut on the bias, edges folded under and pressed. This makes it neat and tidy inside, no raveling rags, and on the outside it accentuates the raglan cut.
 7. Put basting stitches at the bottom hemline and gather slightly. Put on a band of fabric (interfaced if necessary), cut 4" (10 cm) wide and folded lengthwise. Length of band equals your hip measurement minus width of front band, which is 4" (10 cm).
 8. Put on front vertical bands, also 4" (10 cm), folded in half.
 9. Gather neckline slightly and put on a collar band 3 1/2" (8 cm) wide, 20" (51 cm) long.
 10. Cut bias fabric strips and cover sleeve hems.
 11. Sew buttonholes and put on buttons (5 or 6).



add seam allowances

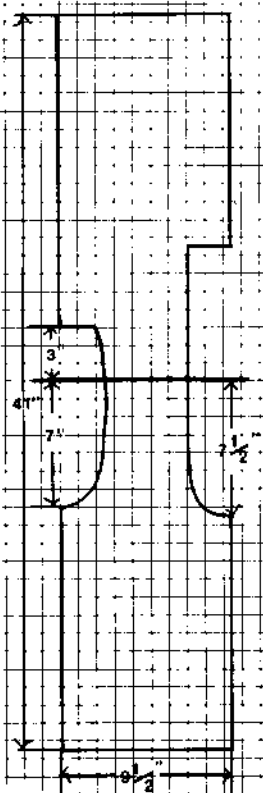

FIGURE 1

YARDAGE: The dimensions given below are for a size 14 jacket.

	Before Wash	Washed
1. Sampler to determine the shrinkage.	10" (25 cm)	8 1/2" (21.5 cm)
2. Back, measured hip to hip + 7" for gathers.	27 1/2" (70 cm)	25 1/2" (65 cm)
3. Front, slightly gathered, deduction for band 2" (5 cm) is made.	12 1/2" (32 cm)	11 1/2" (29 cm)
4. Front #2	12 1/2" (32 cm)	11 1/2" (29 cm)
5. Sleeve, measured from neckline to hand.	32" (81 cm)	28" (71 cm)
6. Sleeve #2	32" (81 cm)	28" (71 cm)
7. Seam allowances 1" (2.5 cm) each side on five pieces.	10" (25 cm)	—
8. Loomwaste	21" (54 cm)	—
Totals	41 3/4 yds. (4 m)	15% Shrinkage

AN AFRICAN STRIP-CLOTH SHIRT WITHOUT STRIPS

by Eileen O'Connor

A Ghanaian "fugu" has been a treasured garment of mine for many years. A gift from friends returning from Africa, it has been much worn and admired. One friend had eyed it so enviously that I decided to make him a similar shirt.

The original fugu is a simple rectangular garment made of 4" (10 cm) wide strips of handwoven cotton. To give fullness and shape to the garment, there are triangular inserts in four of the front and back seams. While weaving a long narrow strip of fabric is certainly feasible, I was intrigued by the idea of achieving the same effect while weaving a shorter, wider piece of fabric.

My warp was as wide as the garment is long (plus shrinkage and pull-in), and as long as the width around the bottom edge plus the width around the bottom of a sleeve (plus shrinkage and take up). Figure 1 shows the warp layout for the garment.

The entire garment was woven in plain weave with cotton linen and cotton wefts on a cotton warp. Starting at one side of the front piece, I wove the full width of the warp to where I

wanted the first 'insert'. I then switched to a different color weft and wove four shots across the right-hand 2" (51 mm) of warp. On each subsequent shot I moved an inch (25 mm) farther left, gradually building up a triangular shape. Every six or eight shots, I put in one shot of thick yarn, from the left, to keep the beat even. When I

reached the apex of the triangular insert, I began decreasing an inch every shot. At the end of the insert I resumed weaving the full width of the warp until I was ready for another insert. I wove eight inserts (four each, back and front) this way. Photo 1 shows the front and back sections as they came off the loom

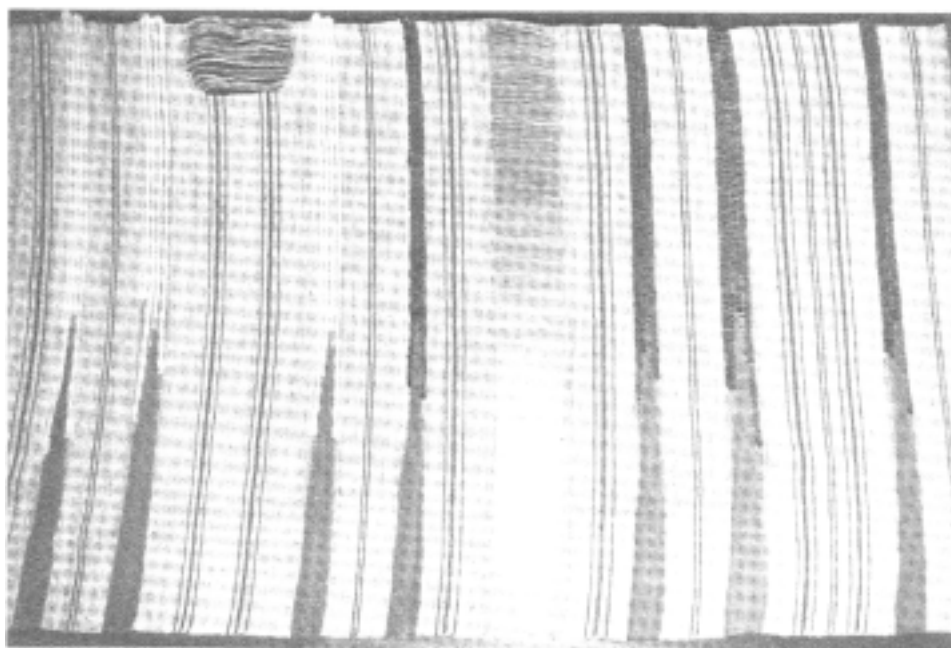

Photo 1. Front and back sections of the garment as they came off the loom. The thick filler yarn is visible above the dark triangular inserts.

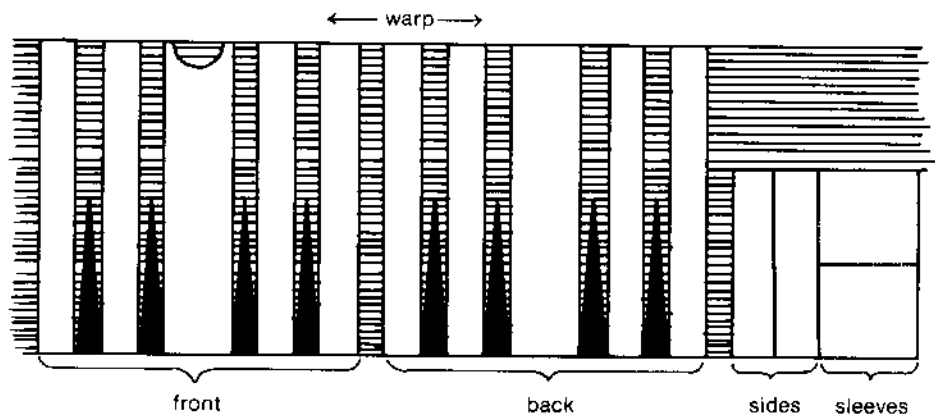

FIGURE 1. Warp layout for the garment. Striped areas were left unwoven. Dotted lines indicate cutting lines.

Once the fabric was off the loom, the hard part began. The thick filler yarn was removed and the warp threads had to be pulled from the unwoven areas above and around the triangular inserts to the edges of the fabric. The warp threads were pulled *before* the fabric was washed.

After much trial and error and threats of abandoning the whole project, I worked out a system for pulling the warp threads without pulling out my hair. I clamped the fabric between two flat pieces of wood and spongy pack-



Photo 4. Eileen O'Connor in Ghanian fugu and Dennis Hanzlick in woven adaptation.

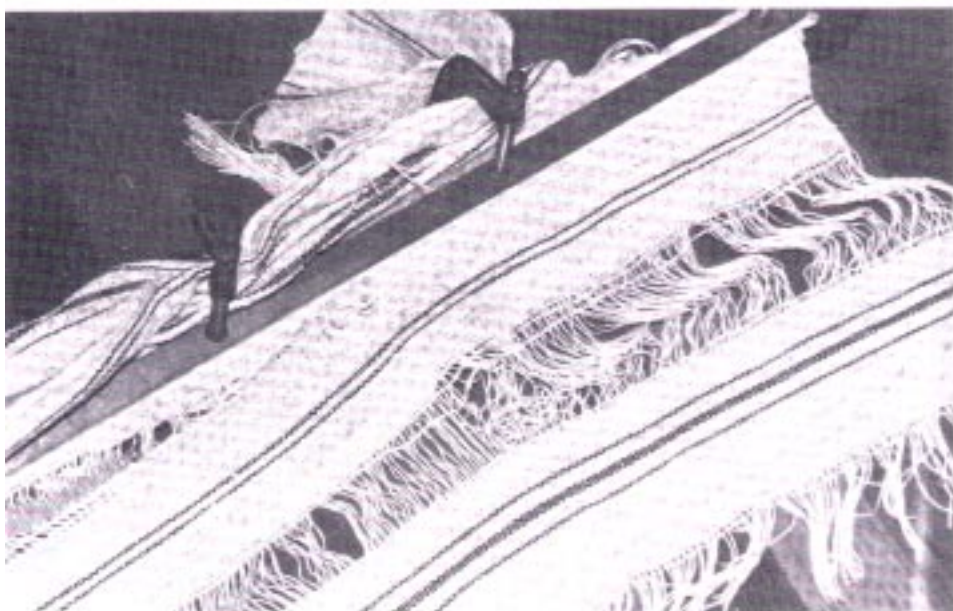

Photo 2. Arrangement of clamps to simplify the warp pulling. The upper part of one gap has already been closed up.

ing material. The spongy material was necessary as the wood alone did not grip all the threads uniformly. The wooden strips were clamped as close as possible along the inside of one of the center gaps. Threads were then pulled one at a time into the next gap. Photo 2 shows the clamp arrangement. When the whole width of the warp had been closed up, the clamps were moved to the next gap and the process was repeated, pulling the threads from the edge of the piece. Pulling from the edge across two gaps caused too much distortion of the weave at the edges. Photo 3 shows the front section after two gaps were closed.

After all the gaps around the inserts were closed, the warp edges of the garment pieces were machine zig-zagged and all the pieces were machine washed and dried. The washing and drying straightened out the stripes and evened out the weave which had been somewhat distorted by the warp pulling. The pieces were then machine stitched together at sides, shoulders, and sleeves. Selvages at bottom edges of garment and sleeves were left as is.

As can be seen in Photo 4, the project was a success. I am wearing the original fugu, and Dennis is wearing the adaptation.

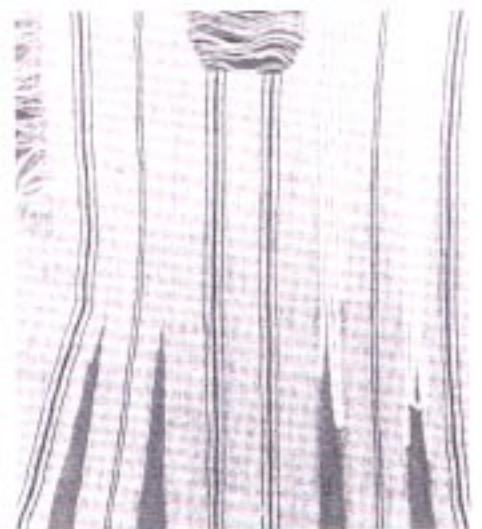

Photo 3. Front section of the garment after two of the gaps have been closed. Notice that the pulling process has caused the weft stripes to be a little wiggly.

GARMENTS BY HANNI BUREKER

CARDIGAN JACKET

Among the many features that can be observed in fashion of this year there is a definite trend toward quality and a desire for natural simplicity. These characteristics are evident in this handsome handspun cardigan jacket.

Natural-colored handspun yarn (less than one lb.) was used for pattern floats on a plain weave background of thinner commercial wool which gave the fabric a firm handle for tailoring. The pattern is McCalls 6980, very simple with only 4 pattern pieces. The facing was omitted and the jacket was lined with a soft lightweight cotton-polyester to within $\frac{1}{4}$ " (6.4 mm) of the front and neck edges.

WARP: Shetland wool, 2 ply, light oatmeal or ecru, approx. 2200 yards per pound (4430 m/kg) (TEXERE yarns, Bradford, England)

WEFT:

Pattern- Irregular handspun wool in natural color.

Tabby- Same as warp, or wool single, slightly thinner than warp, ecru.

SETT: 15 epi (60/10 cm)

WIDTH IN THE REED: 33 in. (82.5 cm)

LENGTH OF WARP: 94 in. (240 cm) plus loom waste for lined jacket; 120 in. (305 cm) plus loom waste for unlined jacket (to allow for facings).

THREADING, TIE-UP AND TREADLING:

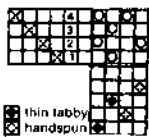

Alternate pattern shots of handspun with thin tabby shots.

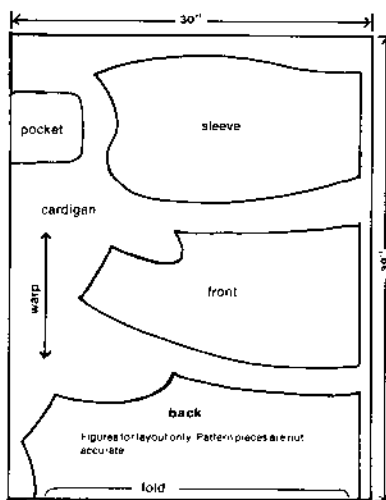

WEAVING INSTRUCTIONS: For the lined jacket in size 12 a finished piece (after washing) measuring 78 in. x 30 in. (198 cm x 76 cm), is needed. 12 in. (30 cm) more should be woven to allow for shrinkage and take-up — 90 in. (229 cm) in all. For bigger sizes, 2 or 3 in. should be added. For an unlined jacket, 25 in. (63 cm) in plain tabby should be woven in addition to the patterned 90 in., for facings.

FINISHING: Wash the material in hand-hot water and Woolite, squeezing gently. Rinse well in lukewarm water, roll on slatted roller to dry, or roll first in bath towel, then finish drying by rolling out flat.

Press lightly from the wrong side.

SEWING INSTRUCTIONS FOR CARDIGAN JACKET

1. The 4 pattern pieces are placed at right angles to the warp, on the fabric folded in half along the weft.
2. Facings for unlined jacket are placed on the tabby piece: back-facing in direction of warp, frontfacings at right angles to it.
3. Every cut edge on every piece should be zig-zagged before assembly.
4. Sew jacket as instructed in pattern sewing guide.

5. For the lined jacket, to give a more stable edge to the front and neck, a straight seam tape should be centered over the folding edges (stitching lines on the pattern) and sewn by hand. Press seam allowances to inside of jacket and tack on, by hand. On the unlined jacket, all seam allowances should be encased with wide bias-tape.
6. For the lining, $1\frac{1}{2}$ yards (137 cm) of 44 in. (112 cm) material is needed. After assembly, the lining gets hemmed into the jacket (turned inside out), about $\frac{1}{4}$ in. (6.4 mm) inside the folding lines.



SLEEVELESS VEST

And why not bring a straightforward sleeveless jacket up to date with braided trim? If you wish use gleaming metallic for ornamentation of this garment.

This vest was woven on the same warp as the handspun jacket.

WARP: Sherland wool, 2 ply, approx. 2200 yards/lb (4430 m/kg).

WEFT:

Tabby- same as warp

Pattern- 2 ply wool, approx. 1800 yards/lb. (3630 m/kg) in 3 colors.

SETT: 15 epi (60/10 cm).

WIDTH IN THE REED: 33" (82.5 cm).

LENGTH OF THE WARP: 53" (135 cm) + loom waste.

WEAVING INSTRUCTIONS: Weave 3" (7.6 cm) of plain weave for the front facing. Weave 46" (117 cm) of pattern. This allows for 10% shrinkage and makes a garment size 12-14. Weave 3" (7.6 cm) of plain weave for other front facing.



THREADING, TIE-UP AND TREADLING:

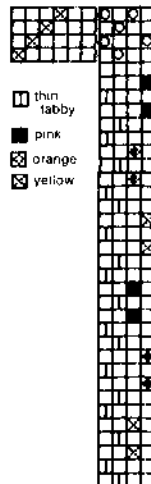

Your piece should now measure about 42 in. (107 cm) without facings. Fold it in half along the weft—the vest is cut out at right angles to the warp. You can use a blouse or jacket pattern with straight side seams and no bust-darts to get the correct shape and placement of the armholes, shoulders and necklines.

FINISHING: Wash in hand-hot water with Woolite, rinse well, let dry slowly. Press from wrong side.

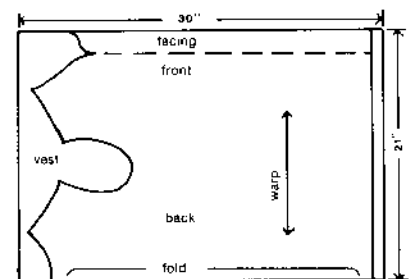

SEWING INSTRUCTIONS FOR VEST

Sew shoulders. Encase seam-selvages in wide bias-tape. Cut off half the seam-allowance on neck edges and armholes. Zig-zag. Sew narrow edge of wide bias-tape around armholes and neck edge (to within 1 in. (25.4 mm) of the facings) on right side of vest.

Turn to wrong side, press and hem down by hand. Encase long edges of facings in wide bias-tape, turn to right side, and sew neck edge along seamline, right sides together. Turn to wrong side and press. Turn up hem to desired length. Since it is a warp selvedge there is no need for a special finish. Hem in place.

HOODED JACKET

The folkloric trend in today's fashion is seen in this warm and stylish jacket in wool, with Rosepath stripes in a combination of overshot and bound-weave. This was fun to weave and easy to sew with elastic at wrists and hip, a front zipper and dropped shoulders. I used a Vogue pattern, put pockets into the side-seams and lined the jacket with a brushed cotton for added warmth.

WARP: 16-cut Cheviot wool (T. M. Hunter, Brora, Scotland). Two shades of blue together and treated as one single end and pick.

WEFT:

Tabby— same as warp.

Pattern— thick wool single from Greece in beige (B), fawn (F) and copper (C).

SETT: 12 doubled cpi. (50/10 cm)

WIDTH IN REED: 35½" (90 cm)

LENGTH OF WARP: 190" (482 cm)

MATERIALS NEEDED: 21 oz. of each blue = 42 oz. (1190 g); beige = 2½ oz. (71 g); fawn = 1½ oz. (42.5 g); copper = 2 oz. (56.7 g).

WEAVING INSTRUCTIONS: Start with the back. Weave 4" (10 cm) in blue tabby. Now the 7" (18 cm) wide stripe as in Fig. 1. Start the wide stripe at *, weave down to the center of band, and back up to *. Use tabby only where indicated on Fig. 1. After the band, weave 24" (60 cm) of tabby. This completes the back. Weave 2 rows of a contrasting color, as a cutting aid.

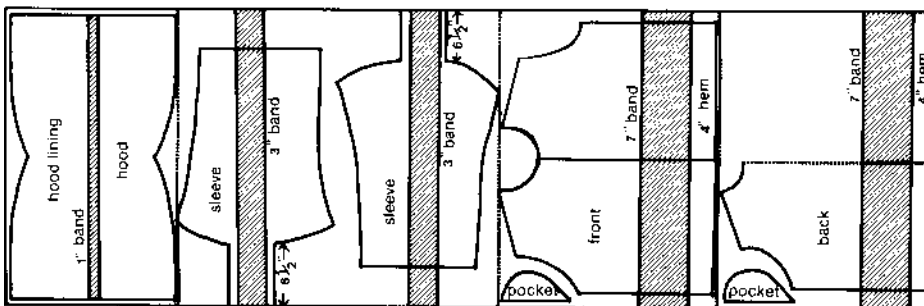

THREADING, TIE-UP AND TREADLING:

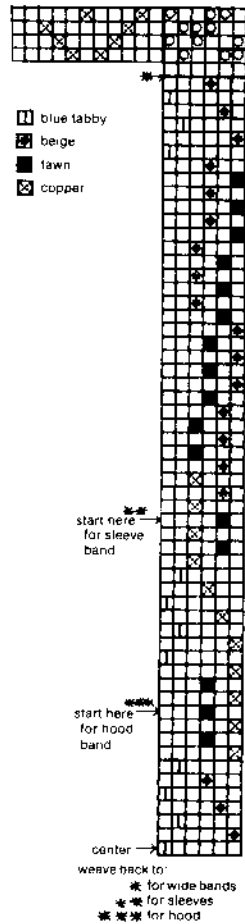

FIGURE 1

Now weave exactly the same piece again (4" hem, 7" pattern stripe, 24" tabby), for the two fronts. Then 2 contrasting rows.

The sleeves: Weave 11½" (29 cm) tabby, then the 3" (7.6 cm) snipe: Start at ** on Fig. 1, weave to center of band, and back to **. Now weave 22" (56 cm) of

tabby, then the 3" stripe again for the second sleeve. Finish with 11½" (29 cm) of tabby. Two contrasting rows.

Now the hood: 12" (30 cm) tabby, then the 1.2" (3 cm) wide band for the drawstring: Weave from *** to center of band and back to ***. Now weave 13½" (34 cm) tabby—this will be the lining of the hood. Two contrasting rows. End of weaving!

Wash the whole piece in hand-hot water and Woolite, with quite a bit of squeezing. Let it soak for 20 minutes, then rise well in warm water. Let it dry slowly—preferably on a slatted roller*. Lightly steam-press your material, if necessary.

Sewing instructions for hooded jacket, page 43.

Directions on making a slatted roller, see: *Simple Weaving* by Hilary Chetwynd, Watson-Guptill, N.Y. 1969





photo by Karen Bashore



photo by Karen Bashore

*Far left.
Costume with short gown
and two petticoats (one
"rucked up"—rhymes
with "tucked up"—an
18th Century custom—
made the hips look larger
and therefore the waist
smaller, also lifted the
upper skirt above the mud
and brambles).*

*Left.
Costume with one
petticoat and bodice*

18th CENTURY MOLLIE COSTUME

by Kathy Spray

One of the requirements of reenacting the Revolutionary War as a member of the Northwest Territory Alliance is to wear an authentic costume. At the first event I attended, "The Feast of the Hunter's Moon", held at Fort Ouiatenon, near Lafayette, Indiana in October of 1979, I was inspired to go a step farther than most reenactors by weaving the cloth for my costume. Connie La Lena had come from Colorado to have a booth at "the Feast"; her fabrics plus the authenticity requirements, examples of other costumes, and my weaving knowledge combined into the beginnings of my weaving project for the next summer.

photo by Wm H. Hagenbuch



*Spinning flax as in the
18th Century. Mollie
costume: two linsey-
woolsey petticoats,
apron and kerchief felt
hat, white linen chemise,
white man's waistcoat.*

Over the winter I researched types of fabrics and the fiber contents of textiles which were commonly used for clothing in the late 18th century. I had chosen to portray a colonial farm woman of English ancestry. The style of clothing and type of fabric I chose to make would have to match what my character would have worn. For this reason, I chose to weave linsey-woolsey for the main fabric of my costume.

Linsey-woolsey, a plain weave fabric in which the warp was linen and the weft was wool, was a commonly used fabric in the American colonies. Most families produced linen for their own use, but wool was not always as plentiful. Linsey-woolsey combined the strength of the linen and the warmth and resiliency of the wool to produce a very durable fabric.

In the spring of 1980, a friend offered me the use of her barn loom on which to weave my costume fabric. The loom is an old rug loom with the same type of large superstructure and overhead beater seen on 18th century looms. It was exciting to be able to weave my costume fabric on a loom so similar to those used in the late 1700's.

The loom was housed in a small room in a barn. It was moved to this location about 30 years ago, and had never been used since. It probably had not been used since 1920. So, my first task was to clean up the loom and the room, and replace the old rotten string heddles (800 of them).

The warp I used was 20/1 linen in off-white. From a small sample woven on my table loom, I decided to weave the yardage at 26 epi (100/10 cm). Eighteenth century fabric was often woven about 30" (76 cm) wide, so I wound a warp that would be 30 3/4" (78 cm) in the reed. After washing, the fabric measured 28" (71 cm) wide.

Having completed the warping and threading of the heddles and reed, and tying onto the apron rod, I began to weave. I wove 11 1/2 yds (10.5 m) of linsey-woolsey, using 2/18 green wool and a single ply yellow wool. Nine and a half yards (8.7 m) of this was solid

green, while the remaining 2 yards (1.8 m) were green and yellow striped. Both colors can be reproduced using natural dyes and mordants available to the American colonists. In fact, I dyed the yellow yarn with onion skins using an alum mordant. The striped fabric became a short petticoat (or skirt in modern terms), while the solid green linsey-woolsey was made into a long petticoat, a bodice (vest) and the lining of a short gown (sleeved bodice).

After completing the first 13 yard warp (which produced 11 1/2 yards of fabric), I wound another shorter warp of the remaining 20/1 linen yarn as the weft. This produced 4 yards (3.66 m) of linen fabric (from a 5 yard warp) from which I lined the bodice and made an apron, a headkerchief, and a pocket. In the late 18th century, pockets were separate, bag-like pieces of clothing which were hung from a string tied around the waist.

Over the winter of 1980, I wove a twill fabric for the short gown from 2/18 wool which I had dyed with black walnut hulls.

By the next spring, I had a handwoven, 18th century costume consisting of 2 petticoats, a bodice (for warm weather), a short gown (for cold weather), an apron, a pocket, and a headkerchief. I had also made a chemise (the undergarment, blouse, and nightgown of the 18th century) from an old linen tablecloth.

My costume has seen much use since it was completed. I have worn it to Revolutionary War reenactments, and when demonstrating flax spinning at festivals and for groups. And this past winter it has been on display for 3 months at a coverlet show sponsored by a local historical society.

Linsey-woolsey, linen, and wool fabrics have been a good choice for my costume. I have worn it in very hot weather without too much discomfort, and in cold snowy weather I could wear the short gown, without being chilled. I enjoyed making the costume and now I enjoy it again every time I wear it, knowing that I am dressed authentically. ❧

ACCESSORIES



STYLISH NO-SEW HAT by Barbara Anderson

Many weavers complain about the amount of time spent sewing and finishing garments and accessories; time they would prefer to use weaving. In the search for attractive and useful quick-to-finish handwovens, I discovered a rather rakish hat that fits those requirements. The hat can be woven at the end of a warp as an afterthought, or easily measured out for a production item.

The warp should be 15 inches (38 cm) wide; a wider warp can be divided up to do 2 or more at a time. Plain tabby weave, twill, or pattern weave are all appropriate. The hat is woven 25-26 inches (63-66 cm) long, plus a fringe allowance at each end of 5-7 (13-18 cm) inches. In determining woven length, allow for shrinkage and loom take-up. The fringe can be short or long, depending on your taste, but allow enough for knotting.

Wash the piece after removing from the loom. To complete the hat, fold it in half, fringed edges together. At one selvedge, turn up a two inch (51 mm) cuff. Divide the warp ends into even bundles and tie in knots, bringing the

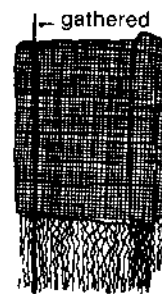

ACCESSORIES

top and bottom layers together. You will be working with four layers at this point, so keep the bundles small. Measure the circumference before moving on, and if the hat is too large, unravel a few weft threads and reknit.

Mark a point about 2 inches from the opposite selvedge and pull up 4 or 5 warp threads to gather the top closed. Ease these pulled threads carefully so they don't break. The finished hat should measure 8-9 inches (20-23 cm) from cuffed edge to top closing.

Divide remaining warp ends into even groups and knot the length of the hat. Steam press cuff in place, or tack lightly. Trim fringe to desired length and wear!

Fringe bundles can be wrapped instead of knotted and feathers can be secured into the wrappings. Long fringe, wrapped and feathered, makes a strong fashion statement! Brushed wools and mohair make an especially elegant hat, and handspun yarn sets it apart from the crowd. Brush hat vigorously for a fluffy look. ❧

BAGS

by Nancy Meiling

For centuries people have found a need for containers to carry more than their hands can hold. Hand bags, tote bags, shopping bags, shoulder bags, camera bags—almost everyone uses a bag at some time every day.

My fascination with interesting and unusual bags has been strong for a long time. I find that ideas for making bags seem to emerge from everywhere—museum displays, house sales where an unusual old handle or a piece of special fabric may crop up, antique shops, etc.

FUROSHIKI is a Japanese word meaning wrapper. The Furoshiki bag has a novel fold which reminds me of Japanese Origami, the design of useful and decorative objects made by folding paper.



Furoshiki bag woven with handspun yarn

To make a FUROSHIKI, start with a rectangular piece of fabric three times as long as it is wide. Fold and sew the fabric according to the pattern of Fig. 1. Then pull up on the two corners "C" (not sewn) and you will see the shape change. The handle is attached to these corners. This bag can be made any size. I suggest that you experiment with different fabrics. The weft of the fabric for my FUROSHIKI was some of the first wool I had spun and dyed.

The SALT BAG caught my eye during a visit to the Chicago Field Museum which had a show of Nomadic Weav-

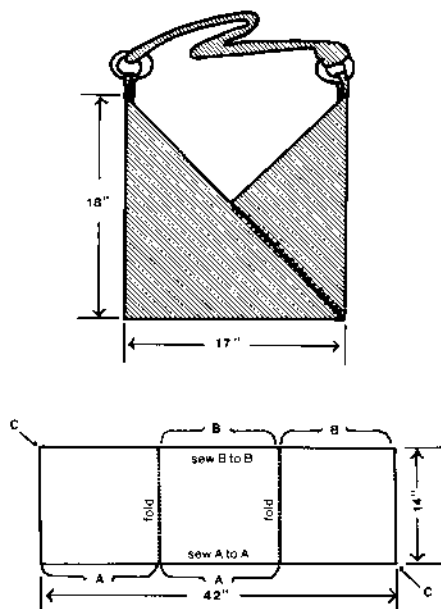

FIGURE 1. Furoshiki bag



Bag inspired by the Eastern salt bag

ings. The Bedouins have developed those unique containers to carry their belongings because these Middle-Eastern people have no permanent home. The Salt Bag has a narrow opening which is folded down and secured for traveling. It inspired me to make a purse. My SALT BAG was made from a piece of old, hand-woven fabric. It is red blue and black striped, with an embroidered design on the surface of the material. To simulate wrapped threads on either side of the opening of the original salt bag, tassels were made and attached there. Old brass bells were also sewn to the bag as they are typical ornamentation on Mid-Eastern garments and accessories. Black wool fabric was used for the shoulder-type handle. ❧



Salt bag, courtesy of Museum of Mankind, London

MULTIPLE SHAFT WEAVING

TIE-UPS FOR 2 OR MORE TIE BLOCK WEAVES

In this second installment on two- or more-tie blockweaves we will discuss the tie-ups and some treadling rules. The first installment appeared on pp. 42-43 of the Fall issue of *The Weaver's Journal*, (Issue 22) and dealt with threadings. In the following installments we will deal with specific weave structures belonging to this group of weaves. There will be a lot of cross-reference between the various installments of this study.

Let us remember that these fabrics have weft patterning caused by weft floats which are tied down at regular intervals by a tie-down warp. The technique of deriving the threadings of these weaves by the superposition of two separate threading drafts leads to some very logical rules for establishing tie-ups.

The threading draft of the tie-down warp establishes in which way the pattern picks will be tied down. That warp is on the front shafts. The threading draft of the pattern warp establishes where in the fabric the pattern pick will make floats on the surface of the fabric and thus establishes the pattern area against the background area. It is the draft for the warp ends of the back shafts.

The tie-down warp and the pattern warp may alternate in a 1-1 order as in Fig. 1 (I,1,A) or in various others as in Fig. 2 (II,4,B).

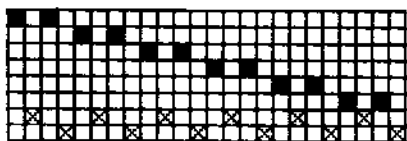

FIGURE 1. (I,1,B)

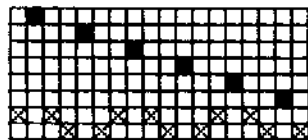

FIGURE 2. (II,4,B)

In order to best understand the tie-up and treadling systems for these weaves, and in order to cut down on the number of needles required to weave a certain pattern, it is best to think in terms of several sets of treadles which will be pedaled at the same time. The left foot will control the tie-down

shafts, the right foot the pattern shafts.

The left treadles are tied up for the pattern on which the tie-down warp has been threaded. These patterns are most often plain weave, basket weave, or 3 or 4 shaft twills. Fig. 3 shows commonly-used tie-up systems for the tie down warp but the choice is by no means limited to these.

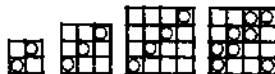

FIGURE 3

The right treadles are tied to one or more pattern shafts. The tie-up and the treadling order is dictated by the design. The treadle for a particular treadling block is always tied to the pattern shafts of the background area, i.e. one lifts the pattern shafts where the floats do *not* appear on the surface. See Fig. 4.

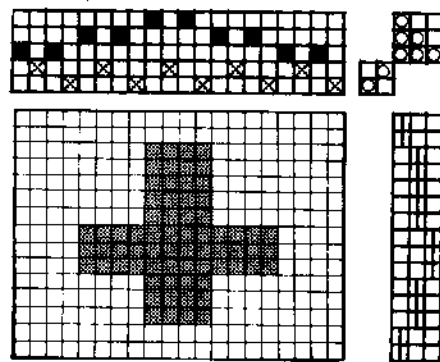

FIGURE 4

For each pattern pick put the left foot on a treadle of the left set and the right foot on a treadle of the right set. In areas where the pattern goes from sel-

vedge to selvedge (no background), use only the left foot.

Remember that each foot controls a completely different part of the manifold draft. In Fig. 5 where the pattern weft is tied down according to a $\frac{1}{2}$ twill, the left foot will keep moving: tr1, tr2, tr3, (repeat), while the right foot will treadle I for as many pattern picks as the design requires and then move to treadle II.



FIGURE 5

So far we have talked about weaving the **pattern picks** which are tied down by warp ends, but weaving these alone will usually not give a **bound** fabric. There are two major ways to design bound fabrics: **supplementary weft** fabrics and **complementary weft** fabrics.

Two-or-more-tie block weaves are usually bound by weaving the designs on a plain weave ground cloth. In this case the pattern picks form a supplementary weft which can be pulled out without substantially destroying the fabric. To weave such a fabric one needs an extra set of treadles to weave the ground cloth and usually alternates a ground pick and a pattern pick during the weaving process. Whenever the draft allows it, plain weave structure is usually chosen for the ground and the ground treadles are so tied as to lift every other thread (Beiderwand is an exception). However plain weave is not always possible and some ground weaves have a more complex structure.

A SHORT AND SWEET DRAWDOWN PROGRAM FOR COMPUTERS

by Earl Barrett

If two-or-more-tie block weaves are chosen to weave weft face cloth then the binding is usually done "on opposites" or, more generally, by means of complementary wefts. Two or more pattern weft picks of different color but same substance will be thrown in succession and will complement each other to do one row of weaving.

For example: For a Summer and Winter rug with a black pattern on a white Background:

left foot	right foot	weave
lift shaft 1 (tie-down)	lift pattern shafts of the background	black
lift shaft 1 (tie-down)	lift pattern shafts of the pattern	white
lift shaft 2 (tie-down)	lift pattern shafts of the background	black
lift shaft 2 (tie-down)	lift pattern shafts of the pattern	white

One has to learn to draw patterns on graph paper and do profile drafts in order to determine which pattern shafts to select for each one of the treadling blocks. When one weaves with two pattern colors B and W, the pattern shafts for weaving B are always the pattern shafts opposite to those for weaving W.

In several of the most recent issues of this journal we have reviewed a number of commercially-available computer programs that produce graphical simulations of weaving. All these programs have one thing in common: they are lengthy and exceedingly complex. Listings of any of these programs would use up from two to five pages of this magazine. This, and the fact that the programs are proprietary, has prevented us from publishing such listings. Also, all of the programs reviewed to date require from 16K to 48K of user memory (RAM) and most call for graphics display capability.

Recently we received a listing of a drawdown program that runs on a Sinclair ZX-80 computer with integer BASIC in ROM and only 1K of user RAM. This program was written and submitted by Richard Clement of 1821 Emerson Drive, Deming, NM 88030. Because this program contains the essence of any weaving simulator, and because is so short, we are reproducing it here as Listing 1. We hope that it will not only serve to open up the field of weaving simulation to owners of

smaller systems, but also serve as a nucleus around which you weavers with a do-it-yourself urge can develop your own more elaborate programs.

The inputs to the program are two numeric character strings. The first HS, is the sequence of harness (shaft) lifts. These are entered as single-digit numbers, *not* separated by spaces or punctuation. This string is a list of pairs of shafts lifted in sequence; each *pair* of numbers in the string represents *two* shafts tied up to one treadle (or one alone by dint of a bit of trickery to be explained later). This is the only major constraint on the kinds of drawdowns that can be produced.

The second input string, TS, is the threading, entered in the same way. Each string is, of course, terminated by a carriage return or "ENTER" command. Line 45 then makes a copy of TS because the latter gets whittled away during subsequent operations. Lines 60 and 70 test to see if the strings have been peeled down to null (empty) strings. CODE(TS) is equivalent to ASC(TS) in most other BASICs; it returns the keycode number for the leftmost character of the string. CODE(T\$) = 1 is a null string in Sinclair keycode.

Lines 80 and 90 comprise the heart of any weaving program. Line 80 looks for a match between the first warp thread and *either* the first *or* second lifted shaft. If a match is found, CHR\$(128), a solid rectangle, is printed at the leftmost edge of the screen or paper. This is accomplished with the aid of the operation TL\$(H\$), which is peculiar to the ZX-80 and deletes the leftmost character of H\$. Thus, after the OR in line 80, the test compares the warp thread with the second shaft. Line 90 looks for the opposite situation (no match with either shaft) and, if this is true, outputs a blank to screen or printer. Note the semicolons at the

```

10 PRINT "ENTER EACH HARNESS LIF
    T SEQUENTIALLY"
20 INPUT H$
25 PRINT H$
30 PRINT "ENTER THREADING SEQUEN
    TIALY FROM LEFT TO RIGHT"
40 INPUT T$
45 LET A$ = T$
50 PRINT T$
60 IF CODE(T$) = 1 THEN GOTO 12
    0
70 IF CODE(H$) = 1 THEN GOTO 16
    0
80 IF CODE(T$) = CODE(H$) OR COD
    E(T$) = CODE(TL$(H$)) THEN PRINT
    CHR$(128);
90 IF NOT (CODE(T$) = CODE(H$))
    AND NOT (CODE(T$) = CODE(T
    L$(H$))) THEN PRINT CHR$(
    0);
100 LET T$ = TL$(T$)
110 GOTO 80
120 PRINT CHR$(0)
125 LET T$ = A$
130 LET H$ = TL$(H$)
140 LET H$ = TL$(H$)
150 GOTO 80
160 STOP
    
```

Listing 1. Drawdown program as written for the Sinclair ZX-80

STATEMENT OF OWNERSHIP, MANAGEMENT AND CIRCULATION		
For the year ending December 31, 1977		
1. Title of Publication: THE WEAVER'S JOURNAL		
2. Issue Frequency: Quarterly		
3. Issue Date for Circulation Data Below: October 1977		
4. Annual Subscription Price: \$12.00		
5. Office of Publication: 255 Broadway, New York, N.Y. 10013		
6. Owner: Earl Barrett, 1821 Emerson Drive, Deming, N.M. 88030		
7. Known Bondholders, Mortgagees, and Other Security Holders: None		
8. Tax Status: None		
9. Publication Title: THE WEAVER'S JOURNAL		
10. Issue Date for Circulation Data Below: October 1977		
11. Extent and Nature of Circulation: 1000		
12. Total Copies (Net Press Run): 1000		
13. Paid and Unpaid Distribution Outside the United States: None		
14. Paid and Unpaid Distribution Within the United States: 1000		
15. Total Copies (Net Press Run): 1000		
16. Total Copies (Net Press Run): 1000		
17. Total Copies (Net Press Run): 1000		
18. Total Copies (Net Press Run): 1000		
19. Total Copies (Net Press Run): 1000		
20. Total Copies (Net Press Run): 1000		
21. Total Copies (Net Press Run): 1000		
22. Total Copies (Net Press Run): 1000		
23. Total Copies (Net Press Run): 1000		
24. Total Copies (Net Press Run): 1000		
25. Total Copies (Net Press Run): 1000		
26. Total Copies (Net Press Run): 1000		
27. Total Copies (Net Press Run): 1000		
28. Total Copies (Net Press Run): 1000		
29. Total Copies (Net Press Run): 1000		
30. Total Copies (Net Press Run): 1000		
31. Total Copies (Net Press Run): 1000		
32. Total Copies (Net Press Run): 1000		
33. Total Copies (Net Press Run): 1000		
34. Total Copies (Net Press Run): 1000		
35. Total Copies (Net Press Run): 1000		
36. Total Copies (Net Press Run): 1000		
37. Total Copies (Net Press Run): 1000		
38. Total Copies (Net Press Run): 1000		
39. Total Copies (Net Press Run): 1000		
40. Total Copies (Net Press Run): 1000		
41. Total Copies (Net Press Run): 1000		
42. Total Copies (Net Press Run): 1000		
43. Total Copies (Net Press Run): 1000		
44. Total Copies (Net Press Run): 1000		
45. Total Copies (Net Press Run): 1000		
46. Total Copies (Net Press Run): 1000		
47. Total Copies (Net Press Run): 1000		
48. Total Copies (Net Press Run): 1000		
49. Total Copies (Net Press Run): 1000		
50. Total Copies (Net Press Run): 1000		
51. Total Copies (Net Press Run): 1000		
52. Total Copies (Net Press Run): 1000		
53. Total Copies (Net Press Run): 1000		
54. Total Copies (Net Press Run): 1000		
55. Total Copies (Net Press Run): 1000		
56. Total Copies (Net Press Run): 1000		
57. Total Copies (Net Press Run): 1000		
58. Total Copies (Net Press Run): 1000		
59. Total Copies (Net Press Run): 1000		
60. Total Copies (Net Press Run): 1000		
61. Total Copies (Net Press Run): 1000		
62. Total Copies (Net Press Run): 1000		
63. Total Copies (Net Press Run): 1000		
64. Total Copies (Net Press Run): 1000		
65. Total Copies (Net Press Run): 1000		
66. Total Copies (Net Press Run): 1000		
67. Total Copies (Net Press Run): 1000		
68. Total Copies (Net Press Run): 1000		
69. Total Copies (Net Press Run): 1000		
70. Total Copies (Net Press Run): 1000		
71. Total Copies (Net Press Run): 1000		
72. Total Copies (Net Press Run): 1000		
73. Total Copies (Net Press Run): 1000		
74. Total Copies (Net Press Run): 1000		
75. Total Copies (Net Press Run): 1000		
76. Total Copies (Net Press Run): 1000		
77. Total Copies (Net Press Run): 1000		
78. Total Copies (Net Press Run): 1000		
79. Total Copies (Net Press Run): 1000		
80. Total Copies (Net Press Run): 1000		
81. Total Copies (Net Press Run): 1000		
82. Total Copies (Net Press Run): 1000		
83. Total Copies (Net Press Run): 1000		
84. Total Copies (Net Press Run): 1000		
85. Total Copies (Net Press Run): 1000		
86. Total Copies (Net Press Run): 1000		
87. Total Copies (Net Press Run): 1000		
88. Total Copies (Net Press Run): 1000		
89. Total Copies (Net Press Run): 1000		
90. Total Copies (Net Press Run): 1000		
91. Total Copies (Net Press Run): 1000		
92. Total Copies (Net Press Run): 1000		
93. Total Copies (Net Press Run): 1000		
94. Total Copies (Net Press Run): 1000		
95. Total Copies (Net Press Run): 1000		
96. Total Copies (Net Press Run): 1000		
97. Total Copies (Net Press Run): 1000		
98. Total Copies (Net Press Run): 1000		
99. Total Copies (Net Press Run): 1000		
100. Total Copies (Net Press Run): 1000		

ends of lines 80 and 90; they are essential to avoid an automatic line feed and carriage return. Line 100 deletes the first thread from the string T\$ and I10 returns to 60 to see if any threads are left. If so, then the process is repeated until all threads have been tested. This completes a weft pick. At that point the program branches to line 120, where the printing of CHR\$(0) causes a line feed and carriage return in readiness for the next pick. Line 135 regenerates the list of threads, while lines 130 and 140 discard the first two shaft lifts, i.e., the first treadling. This establishes the next two shaft lifts as the treadling for the next pick. Finally, when all shaft lifts have been used up, the program jumps from line 70 to the end at line 160.

Because ZX-80 BASIC has such unusual features as the TL\$(T\$) function, we have translated this program into Applesoft BASIC, which is more conventional. Listing 2 gives the result. We have done the translation as literally as possible for the sake of easy comparison. In particular, corresponding line numbers in the two versions do the same job as nearly as possible. The differences are: (1) FOR-NEXT loops are used together with the LEN(T\$) and LEN(H\$) functions to replace the TL\$ function; (2) the use of the MID\$(H\$) function to replace the TL\$(H\$) function in line 80; (3) replacing the solid rectangle (not available on the Apple II screen or our printer) by CHR\$(88) or X; (4) using the space (CHR\$(32)) rather than the null character for a blank; and (5)

using the inequality operator rather than the logical NOT in line 90.

```

XX XXX XXX XXX XXX XXX XXX XX
XX X XX XXX XX XX XXX XX X XX
XX XX X XXX X XX XX
X XX XX X X X X X XX XX X
XX XXX XXX XXX XXX XXX XXX XX
XX X XX XXX XX XX XXX XX X XX
XX XXX XXX XXX XXX XXX XXX XX
X XX XX X X X X X XX XX X
XX XX X XXX X XX XX
XX X XX XXX XX XX XXX XX X XX
XX XXX XXX XXX XXX XXX XXX XX
XX XX X XXX X XX XX
XX X XX XXX XX XX XXX XX X XX
XX XXX XXX XXX XXX XXX XXX XX
XX X XX XXX XX XX XXX XX X XX
XX XX X XXX X XX XX
XX X XX XXX XX XX XXX XX X XX
XX XXX XXX XXX XXX XXX XXX XX

```

FIGURE 1

Fig. 1 shows a drawdown of a 4-shaft extended point twill done with the Applesoft version amended to permit output to the printer. Note that the Apple screen display will permit up to 40 warp threads and 24 weft picks, while if output is sent to the printer the number of warp threads is limited only by the latter (up to 132 on some printers) and twice the number of picks is limited to 255, the maximum size of an Applesoft string. When using the Sinclair version, strings are limited to 26 characters.

If a tie-up of only one shaft to a treadle is desired, the trick is to make one member of a shaft pair an unthreaded one. For example, if a 4-shaft loom is being simulated and only shaft 1 is to be lifted for a pick, then pair shaft 1 with shaft 0 or shaft 5 in H\$.

```

10 HOME PRINT "ENTER EACH HARN
    ESS LIFT SEQUENTIALLY". PRINT
20 INPUT H$: PRINT
30 PRINT "ENTER THREADING SEQUEN
    Tially FROM LEFT TO RIGHT": PRINT
40 INPUT T$: PRINT
50 HOME : PRINT H$: PRINT T$: PRINT
60 FOR I = 1 TO LEN (H$) STEP 2
70 FOR J = 1 TO LEN (T$)
75 B$ = MID$(T$,J) C$ = MID$(
    H$,I) D$ = MID$(H$,I + 1)
80 IF ASC (B$) = ASC (C$) OR ASC
    (B$) = ASC (D$) THEN PRINT
    CHR$(88);
90 IF ASC (B$) < > ASC (C$) AND
    ASC (B$) < > ASC (D$) THEN
    PRINT CHR$(32);
110 NEXT J
120 PRINT CHR$(0)
150 NEXT I
160 END

```

Listing 2. Translation of the drawdown program into Applesoft BASIC

Note that the program is not restricted to four shafts. If only the digits 0 through 9 are used, then the limit is ten. Since, however, it is the *keycodes* that are compared in lines 80 and 90, one can extend the number of shafts to 36 by letting A stand for 10, B for 11, etc. Unfortunately, the tie-up restrictions that allow only one or two shafts to be lifted by each treadle tend to reduce the advantage of this flexibility.

We extend our warmest thanks to Mr. Clement for submitting this simple but highly useful routine. 

SEWING INSTRUCTIONS FOR HOODED JACKET See page 37.

Use Fig. 2 as a pattern lay-out and cutting guide.

After cutting out, zig-zag around all cut edges.

To assemble: Use pattern sewing-guide. Do not make flat fell seams (too bulky). Plain seams with the zig-zag are enough, if you line the jacket. If you don't wish to line it, I would suggest binding all edges in wide bias-tape.

When setting in sleeves, sew only as far as pattern stripes (center them on shoulder seams) on both sides. Clip seam-allowances to end of stitching, press them over pattern stripes on wrong side; turn to outside of jacket and center them over shoulder seams. Stitch down on both sides, close to edges.

In sewing in side-seam pockets, place them high enough so they will not come below the sewing line for the casing.

When making the stringholes in the hood, just push the warp and weft threads apart with a blunt, thick needle. With thin embroidery floss, work buttonhole stitches around, thus making small round buttonholes. No need to cut anything.

Make a drawstring by twisting and plying 12 4-yard (365 cm) strands of your blue yarn. Finished cord should be about 56 in. (142 cm). After inserting into hood, add beads at the ends, if you wish. 

RUG WEAVING: RUG YARNS

by Martha Stanley

There is no perfect rug yarn, but rather numerous yarns of different fiber and spin which include drawbacks among their assets. Desirable qualities are discussed below. But some of these less desirable elements can also be improved on or compensated for by changing the twist of the yarn, the sett of the warp, or the type of weave structure, to name several examples. Some properties cannot be changed and should therefore be avoided. The trick is to learn which drawbacks can be compensated for, in ways which are enhancing.

This article is not intended to discuss all suitable fibers for rugs. It is meant rather to provide some guidelines for selecting yarns.

In evaluating a yarn's properties we must use different criteria if it is to be used for warp or weft and whether for warp-faced weft-faced rugs.

WARP: In **WEFT-FACED** rugs it requires strength and some resistance to abrasion. Generally its staple is quite long, strong, worsted-spun and plied tightly. A slight roughness or hairiness is desirable to prevent the weft from moving along it during wear. If the warp is used for **WARP-FACED** weaves in addition to the above it must also resist abrasion pretty well. Substantial hairiness here can present difficulties in changing the sheds while weaving because of the denseness of the threads.

WEFT: In **WEFT-FACED** rugs the yarn is also worsted-spun; a good deal of twist is desirable, particularly if the yarn is single ply. It needs to be quite abrasion resistant and at least somewhat elastic and supple or it will not undulate properly around the warp threads and pack in well. The more hairy or fuzzy the yarn is the more it camouflages the weave. In **WARP-FACED** rugs abrasion resistance and suppleness are not particularly critical in the weft.

Let us now look at the fibers themselves. Ideally they should be 3-5" (7.6-13 cm) long or longer, relatively coarse, strong, and straight or wavy rather than heavily crimped.

To elaborate or explain: If the fiber's length is not sufficient it will not be locked as well into the spin and ply of the yarn and can work loose more readily. A weft-faced rug of shorter staple weft ought to have the warp sett closer and minimum-length floats of weft on the surface.

Coarse fibers are less inclined to felt or pill with wear. If you've dyed both fine and coarse staple yarns you will have noted how much less the dye penetrates the coarser fibers.

Warp yarns, in particular, need to be strong. But you want strong *staple* in any rug yarn.

A rug yarn should not be spongy. And while this quality is generally controlled by the way the fibers are prepared and spun, you want to avoid heavily crimped fibers. In the finished yarns the fibers need to lie parallel in a solid core. Straight or loosely waved fibers achieve this best.

For rugs worsted-spinning is necessary. The fibers are combed parallel, then drawn out and twisted. This produces a yarn of greater strength and without the sponginess of woolen spinning. The carding of the fibers in woolen-spinning may provide desired softness and insulation in a shawl; carding (as opposed to combing) results in airiness and space between the fibers in the spun yarn which can be abraded more quickly in a rug. Besides, longer and coarser staple fibers are easier to comb than to card.

Generally weft-faced rugs in this country are not woven with a denser warp sett than 3-8 ends per inch (12-30/10 cm) for tabby. Consequently the weft must have a great deal of spin to

lock the individual fibers in more securely. If the yarn is to be a plied yarn, several of these spun strands are then twisted together in the opposite direction. Plied yarns are stronger and more resistant to abrasion than singles—provided that there is enough twist in the original strands. If not, the plying may loosen the fibers. Singles yarns, though more vulnerable, reflect the light off their surface better and more handsomely, revealing the three-dimensional quality of a flat-weave's surface. Color also appears more saturated in a single ply yarn.

I have a personal preference for more twist in rug yarns than is generally found in commercial rug yarns. This extra twist locks in the fibers better, producing greater strength and abrasion resistance, allows the color in a dyed yarn to appear more intense, and helps the yarn to retain its identity in a dense weave. When using a spinning wheel or electric spinner it does not take much time to add this extra twist and it is well worth the effort. If you try this be sure to discipline the yarn after you have added the additional twist, so that it is manageable. Otherwise you will curse both yourself and the author of this article!

Although it requires some additional time, you may spin your own yarn, selecting an appropriate fiber and combing the fibers yourself. You may elect to purchase "combed top". ("Top" indicates all the fibers are graded to be the same length.) You can create the thickness of yarn you wish with the desired number of ply, and with plenty of twist. You must heed one thing: the yarn must be of fairly consistent thickness or the thin areas may absorb too much of the high twist from the thick areas and become brittle.

If you are not spinning your own yarn you may have a difficult time evaluating the twist and the staple of com-

mercial yarns in a yarn shop or from a 2" (50 mm) sample on a mail order sample card. Obtain 12" (30 cm) long samples of yarns to be evaluated. Buy a small skein, inquire if the shop will furnish you with samples this long (shops are rightfully concerned about breaking skeins open for this), or check with a nearby weaver to trade samples.

this abrasion test on each sample and note the differences.

You are now ready to evaluate length and coarseness of staple. You need a single ply from each sample. Unravel each plied yarn to liberate one of the plies. Single ply yarns are ready to go. By now there is steam rising from the kettle. Take a strand, hold it near the

example, if a weft yarn with somewhat less abrasion resistance but great beauty is chosen it ought to be woven in a closer weave. That is, the warp ought to be sett more closely than for a highly resistant yarn, and the weft floats ought to be as short as possible.

From those yarns which best meet the criteria for a rug yarn choose the ones

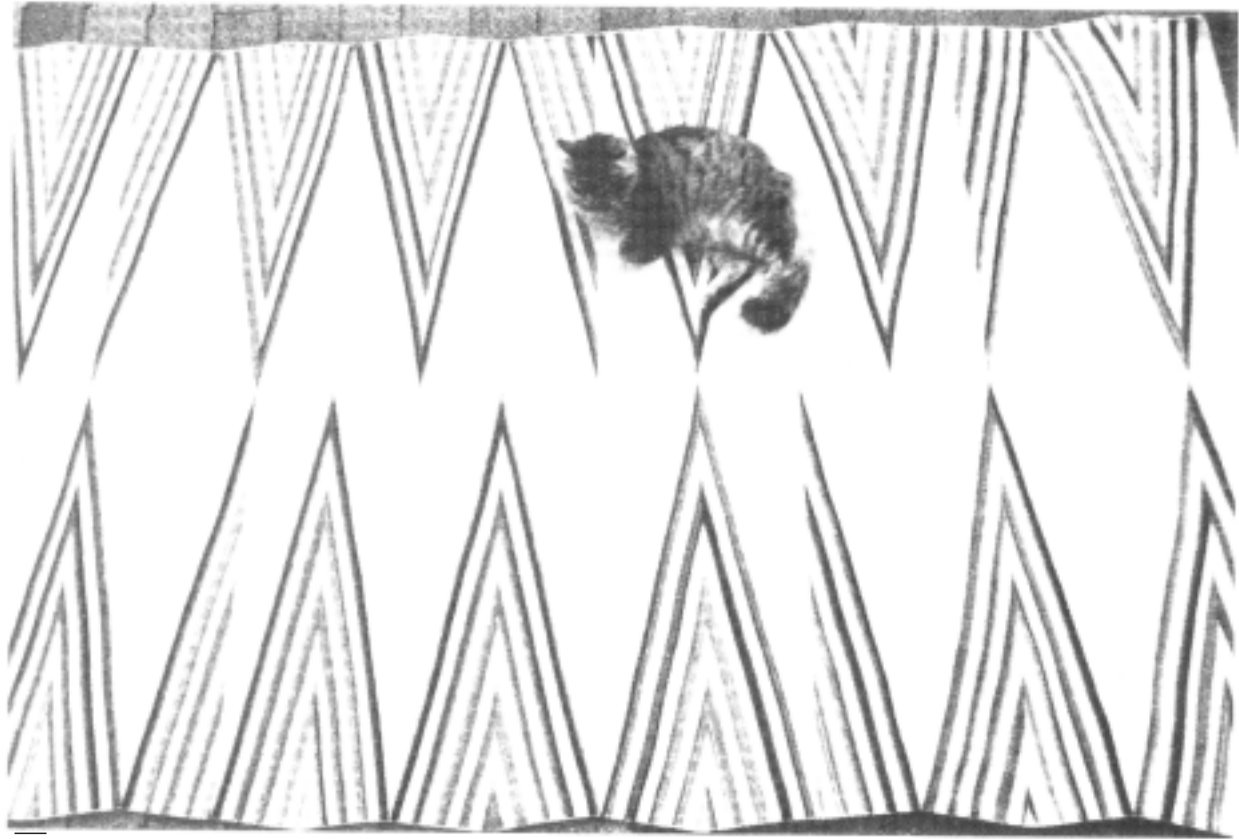

Wedge weave rug by Martha Stanley, 1981, 5'x7'.

Now in the privacy of your studio or kitchen do your testing. Examine several yarns at a time so that you can compare results. Put on the teakettle; you will want some steam. Near one end of each sample try to break the yarn and evaluate its strength; compare it with the strength of other yarns you are testing. Save the broken end as a sample of what the yarn looked like in the store. Next, hold a sample firmly in one hand between thumb and third finger, spanning across a 2-3" (50-75 mm) distance and hold again between middle- and forefinger. Wet the thumb and forefinger of the other hand and run them up and down the taut strand a minute or two to see how the yarn responds to abrasion. Repeat

curl of steam and gently begin to untwist it until the fibers are unspun and parallel. The steam will facilitate this and separate the fibers. Now hold the unspun strand at each end over a table and carefully pull apart. Lay pulled apart segments together and keep repeating this process until you have rearranged the fibers so that they are all parallel and not overlapping lengthwise. It is now fairly easy to measure how long the staple is. A yarn of consistently long fibers is preferable to one with a few long fibers and many short ones.

No yarn is the perfect yarn for rugs. Consequently we must work intelligently with the yarns we choose. For

which you find most handsome. It is not an easy task in rug weaving to show off the quality of the yarn; the weave's density tends to negate any visual quality of the yarn but its color. Yet if you love the yarn you are working with you will find ways to show off its beauty in the weave.

It is misleading to attribute a rug's beauty just to good use of color and design. In truth every ingredient in a rug is contributing either positively or negatively to its appearance. And few would argue that the yarn's role is functionally vital. Let us work to strengthen the impact of its role visually.

© 1981 Martha Stanley

A NEW LOOK AT TWILLS

by Janet A. Hoskins*

Twills are such a fundamental part of hand weaving terminology that it is perhaps somewhat surprising to find that there are many features of these weave structures which, until recently, have not been widely known or well documented. As computer scientists and mathematicians have become interested in the area of structural textiles, the characteristics of the various weave classes have been more rigorously defined and formulas determined for enumerating the members of the various classes. It has been computed, for example, that there are 17 different twills possible on 8 shafts and 13647 possible on 20.¹

Twills can actually be considered as specific cases of a more general class of weave structure. References to these general structures appear in: Nisbet² where they are referred to as rearranged twills; Cyrus-Zetterström³ where the term Satineer is used; and in the *Weaver's Journal*⁴ where they occur as crepe weaves developed from small motifs.

The method of generalizing the twills, as precisely defined in a paper by B. Grunbaum and G. C. Shephard⁵ involves recognizing that it is the first row of the drawdown and the rule for obtaining subsequent rows that is the important feature of the family of twills. In order to determine the twills on, for example 8 shafts, one must determine the set of possible first rows, of length 8, which cannot be changed one into another by the following operations:

1. Replacing black squares in the drawdown by white squares and vice versa
2. Reversing the order of the elements in the rows
3. Cyclic rotation of the row or any combination of the above.

The "twillin" class of weaves introduced by Grunbaum and Shephard involves developing a first row from which subsequent rows are obtained but the rule for deriving these subsequent rows is more general than the one for obtaining twills and the resulting structure is precisely defined as possessing the following characteristics:

1. Each row of the drawdown matrix has the same interlacement series as all of the other rows.
2. Each column of the matrix has the same interlacement series as all of the other columns.
3. The interlacement sequence is the same for the columns as for the rows.
(It could be noted that these properties describe a "mononemal" fabric⁵).
4. The operation that is applied to each row to obtain the next one must be such that each row maintains a constant relationship to the two rows immediately adjacent to it. Usually, this involves shifting one row by an integer number of units to form the next row.
5. Condition 4 is also applied to the columns of the matrix.

6. The operation which applies to the columns must be the same as that which is applied to the rows.

(Conditions 4, 5 and 6 describe "isonemal" fabrics⁵). See Fig. 1C.

Thus, although twills can be described as a type of structure distinct from twillins, this distinction is somewhat artificial in that twills exhibit all of the properties of twillins. Twills are essentially twillins in which the operation that has been applied is a shift of one unit either to the right or to the left. See Fig. 1.A. In actual fact, the definition of twillins is really rather restrictive and there are far fewer non-twill twillins than one might think, so that the greatest proportion of twillins are, in fact twills. See Table 1.

Shafts	Number of Possible Twillins (Including Twills)	Number of Possible Twills*
4	3	3
8	26	17
12	174	121
16	1358	1161

*Includes tabby which is, of course, the simplest twill.

TABLE 1

A further structure can be specified which follows as a natural extension of twillins⁵, in which the rule for obtaining subsequent rows involves a shift of an integer number of units and taking the complement of the new row. The resulting structure, called a color-alternate twillin, has even numbered rows whose interlacement series is the complement of the interlacement series for the odd numbered rows and must conform to all of the rules of isonemality. See Fig. 1.D. As in the case of twills and twillins, color-alternate twills can be considered as a specific case of color-alternate twillins in which the shift value is one. See Fig. 1.B. This weave class introduces a whole range of new patterns, many of which are most striking, especially when used in conjunction with warp and weft yarns of contrasting colors.

References

1. Hoskins, W. D. and Street, Anne Penfold. Twills on N-Harnesses with 2k Breaks, to appear in *The Journal of the Australian Mathematics Society*.
2. Nisbet, H., *Grammar of Textile Design*, 3rd ed., Beem, London, 1927.
3. Cyrus-Zetterström, *Manual of Swedish Weaving*, translation
4. Barrett, Clotilde, Multiple Harness Weaving Course: Part IV Twill Derivations, *The Weaver's Journal*: Volume 5, No. 3, Issue 19, Winter 1981, p. 12-13.
5. Grunbaum, Branko and Shephard, Geoffrey C., Satins and Twills: An Introduction to the Geometry of Fabrics, *Mathematics Magazine*, Volume 53, No. 3; May 1980.

*Department of Clothing and Textiles, University of Manitoba

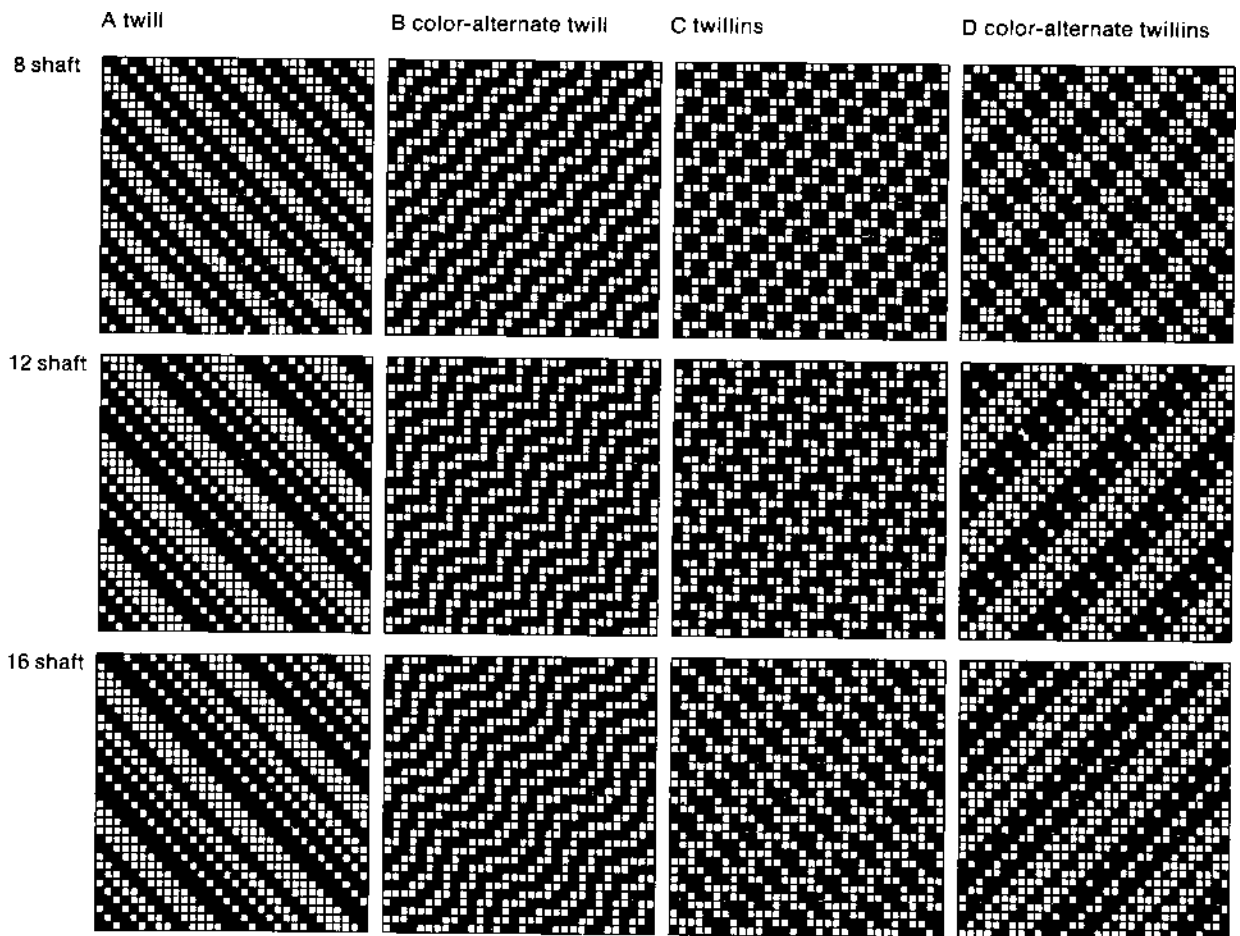
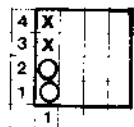

FIGURE 1

UNIVERSAL TIE-UP FOR A 4-SHAFT COUNTERMARCH LOOM

When observing a weaver working at a countermarch loom one notices that during the opening of a shed all the shafts are moving. At the same time as selected shafts rise, all the other shafts sink. Each treadle has thus to be tied to all the shafts. For the rising shafts the treadle is tied to the shaft via the lower lamms (sometimes longer) which in turn are tied to overhead jacks. For the opposite (or sinking) shafts, the same treadle is tied to the shafts via the upper lamms which in turn are tied to the lower heddle bar of the shaft.

FOR EXAMPLE: If with a 4-shaft loom one wants to lift shafts 1 and 2 with treadle 1, one ties treadle one to the first two lower lamms (shafts 1 and 2) and to the last two upper lamms (shafts 3 and 4). Thus:



x-tie to upper lamm
o-tie to lower lamm

With a 4-shaft countermarch loom

there are 14 possible sheds:

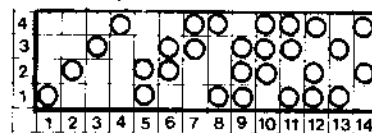

Most looms are not furnished with 14 treadles. However, if your loom is furnished with 8 treadles you can use the universal tie-up and by weaving with both feet at the same time the 14 sheds can easily be obtained.

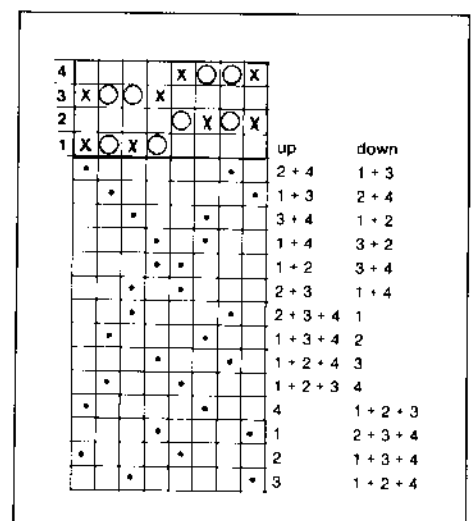
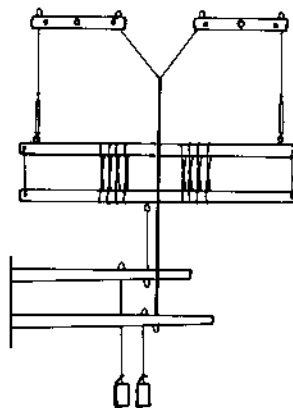

Notice that each treadle is only tied to two shafts and that the left foot controls shafts 1 and 2, the right foot 3 and 4.

Thus, if possible, order your 4-shaft countermarch loom with eight treadles and you will never have to retie the loom!

LENO WITH STEEL DOUP HEDDLES

by Clotilde Barrett

Leno weaving requires a crossing of warp threads. There are several methods by which leno weaves can be produced. These include pick-up sticks, beads, string half heddles and steel doup heddles. The industry uses steel doup heddles exclusively and this slick system can be adopted with great success to handloom weaving. The use of industrial doups by the handweaver will be described here. Because the heddle size varies from loom to loom and because the basic construction of the loom dictates where tensioning bars can be attached, this study will refer to the Macomber loom on which the experiments were made. I used a 2-beam loom with more than four shafts. The second beam and the 5th shaft are not absolutely essential. They were merely used because they were available.

For looms requiring heddles smaller than the standard 12" size the metal doup heddles might be impossible to come by. Looms with shedding mechanisms different from the Macomber may require a variation of the tensioning system described here.

Each heddle is made of 5 parts, the needle (C) which has an eye *a*, and 4 standards, two male (A) and two female (B). See Fig. 1.

To assemble the heddle, insert the male doup standard in the center slot and through the heddle rod slot in the top of the female standard. Two sets of this combination are required for each complete doup. Place the two pairs of doup standards so that the bends above the center point away from each other. Insert the doup needle between the standards of each set so that the doup needle straddles the intersections of the doup standards. See Fig. 2.

To string the doup heddles on the loom, remove all regular heddles from shafts 1 and 2 and follow these steps:

1. The left pair of standards is threaded on the heddle bars of shaft 1 (1st standard).

2. The right pair of standards is threaded on the heddle bars of shaft 2 (2nd standard).

3. The needle with its eye just above the centers straddles both pairs.

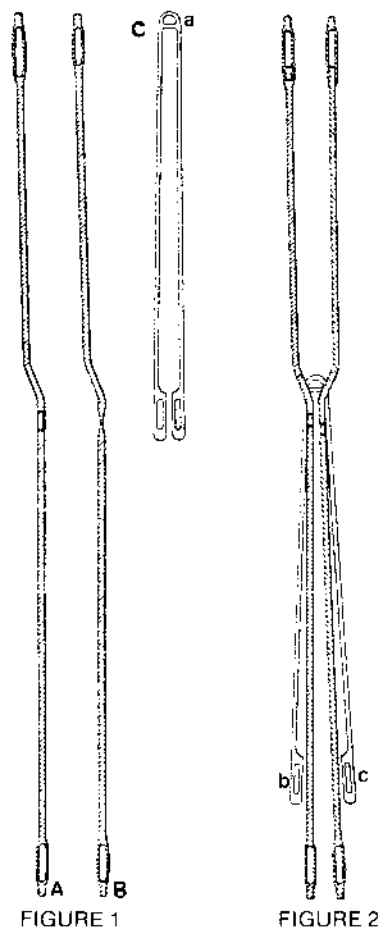

For this study we will weave a leno sample on 1 shafts. Remove all other shafts from the loom. Take the heddle bars from one of the unused frames and slip one of them in front of shaft 1 through the heddle bar slots *b* of the needle. Secure the heddle bar in place with clip pins through the holes at each end. Slip the second heddle bar behind shaft 2 through the heddle bar slots *c* of the needle.

Use one complete doup heddle for each leno crossing.

Prepare a warp with an even spun and plied yarn such as a 2 ply worsted. Beam it on the lower beam of the

loom. Sitting in front of the loom, start on the right-hand side. Thread the first thread through a regular heddle of shaft 4 (**back harness**), the next on shaft 3 (**jumping or ground harness**). Now thread the end which is on shaft 4 (**doup end**) through the eye of the needle from left to right (it helps to lift the heddle bars of the needle). Pass the end which is on shaft 3 (**ground end**) above the eye between standard 1 and standard 2, from left to right. Repeat for each crossing pair.

Sley all the threads of one crossing set through the same dent of the reed. Tie on.

Note that the doup end will be raised either when shaft 1 is up or when shaft 2 is up.

OPEN SHED O Lift shaft 2. This makes the "open shed". See Fig. 3. The doup end will be lifted to the right of the ground end. The ground end stays down between the 1st standard and the needle. Weave. Lower shaft 2.

CROSSING SHED C Lift shaft 1. The ground end slides over the needle to the right and stays between the needle and the second standard while the doup end is lifted to the left. This makes the "crossing shed" (see Fig. 4) and will make a right-hand leno.

PLAIN SHED P On this warp it is also possible to weave plain weave. The "plain weave" shed is made by lifting shaft 3. Alternating the plain shed and the open shed will weave plain weave.

Notice that for this simple weave structure shaft 4 is never lifted. To pass from one shed to another use one of the following sequences: **C O P O P O** **P O P** or **C P O P O P C**. In other words, use the same shed going into plain weave as out.

Try also using multiple picks per shed.

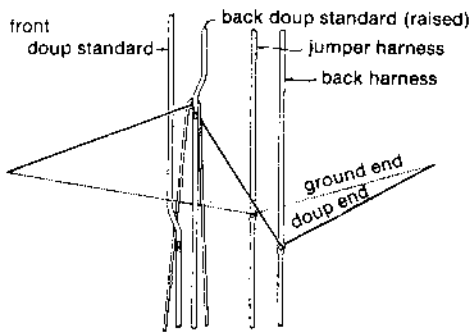

FIGURE 3. Open Shed

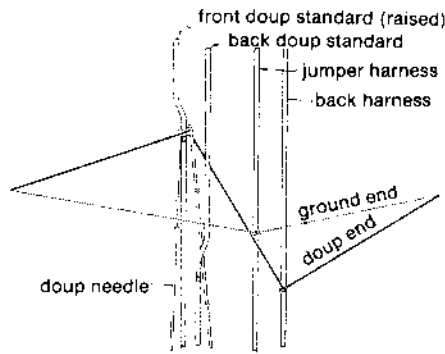

FIGURE 4. Crossing shed

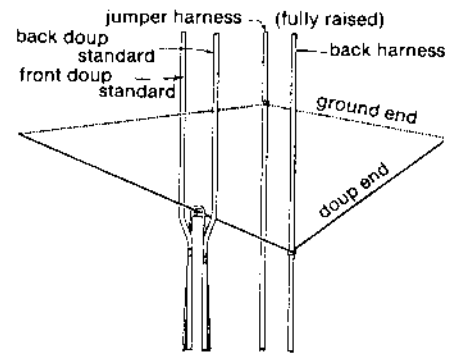

FIGURE 5. Plain shed

It may be necessary to attach small weights at each end of the heddlebars passing through the needles in order to facilitate the return of the needle after shafts 1 and 2 are put down.

SLACKENER

On the crossing shed the doup end is put under great stress as it is required to pass under the ground end before it can open up into a shed. The function of the slackener is to ease this doup end and create a better shed with less danger of breakage.

Between the castle and the back beam, insert pipe A while shaft 4 is lifted. Then lift shaft 3 and insert pipe B. Now slacken the warp and tie pipe A (stationary roll) securely to the upper beam. Weight pipe B (slackener pipe) down with a heavy weight (several pounds). See Fig. 6. Now attach each end of pipe A with a strong cord to the jack-chain-hook system of the last shaft of the loom (the frame has been removed earlier). Adjust the length so

that the jack is at the same level as if it were carrying a frame. Tie the lamm of this jack and shaft 1 to the same treadle. Thus when the first standard is lifted, slackener B will be lifted also. This releases the tension on the doup end and facilitates the crossing. Notice that the ground end passes through its eye (X) slightly higher than the doup end (Y). This facilitates the sliding of the ground thread.

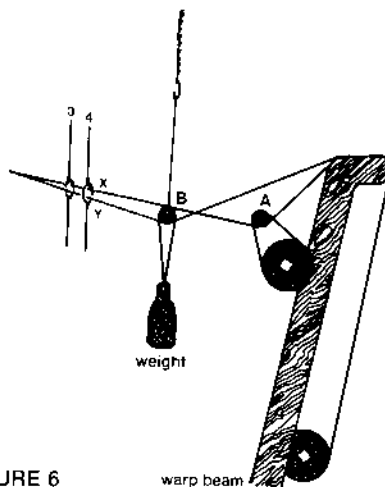

FIGURE 6

LEFT-HAND DOUPS

If during the threading of shafts 3 and 4 the doup end (on 4) is to the right of the ground end (on 3) and the needle is threaded from left to right, the leno is right-hand. If the doup end is to the left of the ground end and the needle is threaded from right to left, the leno is left-hand.

PLAIN WEAVE STRIPES

Plain weave stripes may be threaded on shaft 4 and 1 using regular heddles for both. The treadling will be: Lift 2+4 for the open shed, lift 1 + slackener for the crossing shed. Plain weave stripes should be beamed separately if possible.

Note: Steel doup heddles that fit looms whose normal heddles are about 12-12½" may be ordered from the "Colorado Fiber Center," P.O. Box 2049 Boulder, CO 80306. The cost per complete heddle is \$1.25 +shipping. Minimum order: 10 heddles.

GRANDOR YARNS

British imports

COTTONS: Exotic (see picture) & 10/4 mercerised on ½ lb cones.
 WOOL: Berbers, rovings & fine yarns, NEW LOOPED YARNS.
 MOHAIR: NEW large looped yarn of 95% mohair, 5% wool
 LINEN: Knop (see picture), cotton/linen. Warp yarns 4/6, 8/6, 10/6, 8/3, 12/3, 16/3 & colored 8/5s.
 SILK: "SHANTUNG" range 65% silk & 35% wool. 10 colors, knitting patterns available. 100% silk tussah in 3 colors.
 MORE EXOTIC YARNS... "SOFIA" & "CILICIA" in Colors: mohair or wool mixtures. NEW SUNBEAM MOHAIR in 10 subtle colors.

Domestic Supplies

**RIBBONS... RIBBONS... RIBBONS... bias & straight cut. The latest fashion.
 CHENILLE: 3 & 6 cut, natural & colors.
 McMORRAN YARN BALANCE: still only \$14.95, discounts available.
 "CLOTHING": Barbara Hamaker's book \$7.95, discounts available.

Please note: Yarns are wholesale only. Complete set of samples \$2.75.

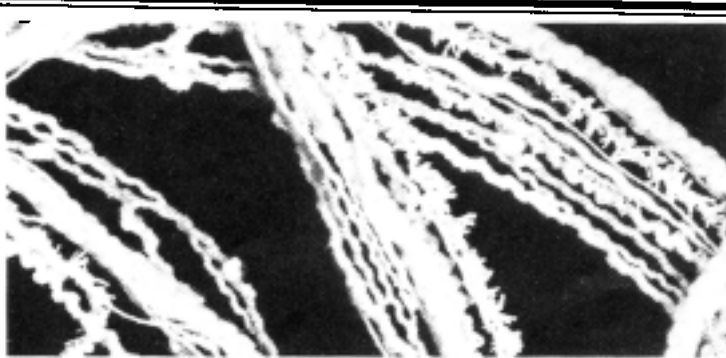

GRANDOR INDUSTRIES LTD.
 Dept WJ, P.O. Box 5831, 4031 Knobhill Drive,
 Sherman Oaks, CA. 91403. (213) 784-5855.

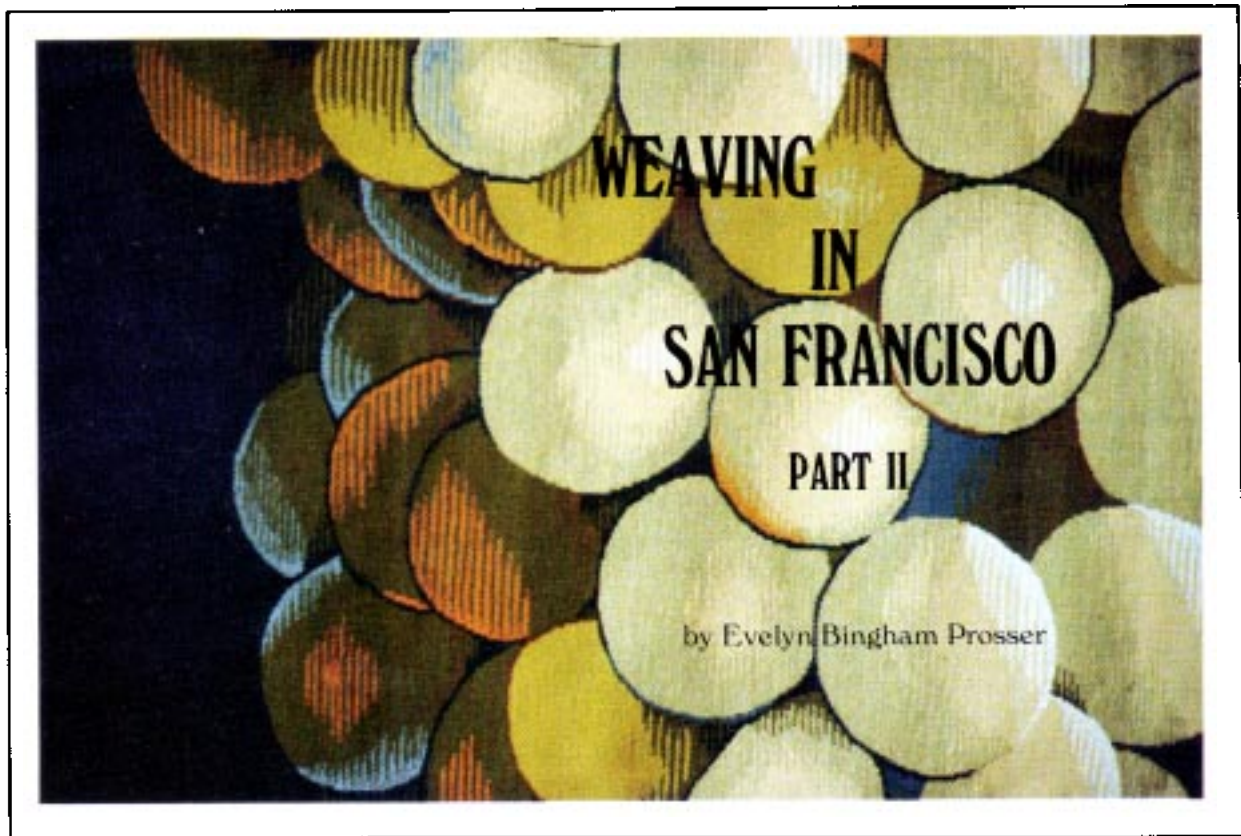

Detail of "Grapes" by Mark Adams

TECHNIQUES

The following paragraph will be defined as the words fall: NOTE the numbers that correspond to their definitions; i.e. pass (1).

"French tapestry is slit (2) tapestry which incorporates double-weft interlock (3) where slits become too long. (Long slits can cause warp distortion and weakness in the tapestry structure.) Curves are made more pleasing and regular by the use of 'Jan's Law' (4) both in the weft sequences (5) and in the warp sequences (6). Straight diagonals should be worked out with sequences also. Hatching (7), and hachures (8) of different varieties and lengths can be used to produce certain effects unique to tapestry. Colors in tapestry should be in high contrast. Color variations may be made by combining several strands for the weft. The effects are straight (9), melange (10), or chine (11). These strands are not plyed (12) and are finger beaten (13) in place after which a comb is used (pulled toward the weaver, not beaten) to straighten out the pass. Headings for hems (14) are woven in at the beginning and the end of the tapestry to be folded to the back. Finishing then takes place. Thus a well made tapestry is created.

(1) PASS—The movement of weft threads through the warp in a round trip. See Fig. 1.

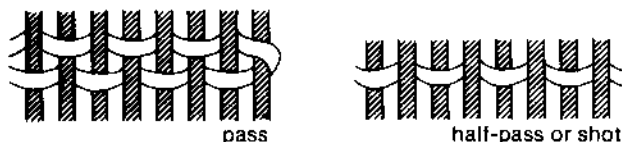

FIGURE 1

(2) SLIT—The separation between two color areas which occurs when passes of two adjacent colors meet and separate without joining. Building up one color area independent of another color creates slits. See Fig. 2.

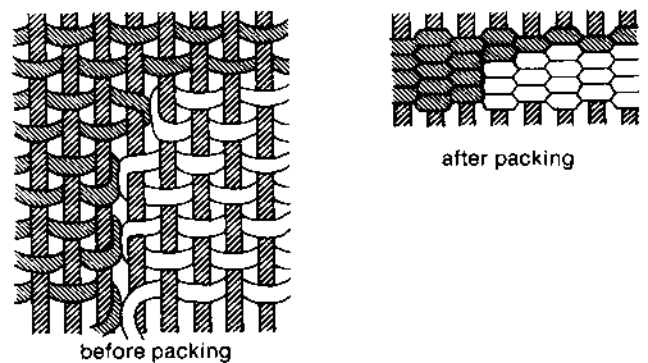

FIGURE 2. Slit

(3) DOUBLE-WEFT INTERLOCK—Joining of two color areas by means of interlocking weft. At the meeting of colors A and B, pass A around the B yarn. Complete a full pass of color A. Take color B and have the yarn go around color A and complete a full pass. Remember that you can mark on the warp the two warp threads that are involved in the double-weft interlock meeting. If there is a succession of slits going up the warp to create an area that is very warp-wise, move the double weft interlock with the design. See Fig. 3.

If the double-weft interlock is to incorporate one color that is covering one thread and if that one thread is between

two colors that should be double-weft interlocked on both sides of the one thread, then think in terms of half-passes (shots). Complete a half-pass in one direction of all three colors. When the warp thread, around which the single-thread color is to go, is toward you, put your color behind the warp thread in passing over the outer two colors. If, in returning your colors to complete the pass, your single warp thread is away from you, then bring the color just over the other two colors and in front of the warp thread. See Fig. 3b.

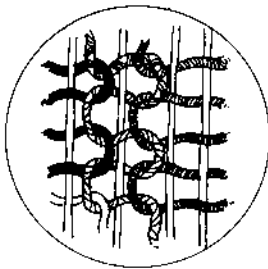
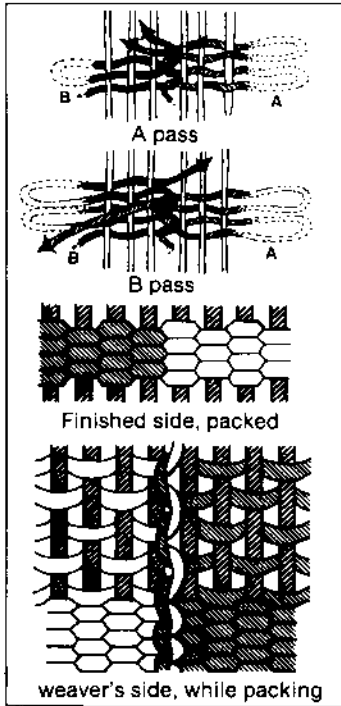

FIGURE 3b

FIGURE 3. Double-weft interlock

(4) 'JAN'S LAW-This was a rediscovery by one of the people, Jan Marie Dubois, working on the Judy Chicago 'Dinner Party' project. The law states that: 'If a smooth diagonal line which is curved or straight is to be developed, one proceeds as follows: when weaving the decreasing color make certain that the last warp thread of a turn for a pass is covered.' See Fig. 4.

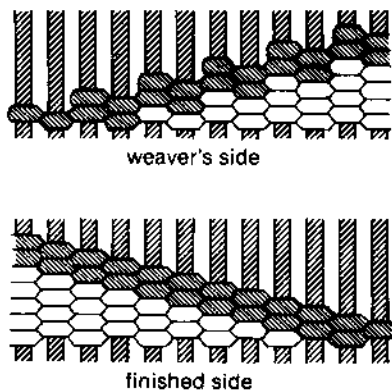

FIGURE 4. "Jan's Law"

Jan's Law', a term used only at the Workshop for student communication, is only the beginning of a concept that is highly developed in Europe. In France, it is known as 'fil plein ou fil creux'—(full thread or empty thread), and, by the British as 'hills and valleys'. It is only truly useful for an angle of two warp threads difference per pass, and can be used to excess. For each weaver incorporating it into his or her weaving, this concept differs according to the extent of use and personal preference.

(5) WEFT SEQUENCES are the decreases (or increases) of warp threads for each pass of a weft color in order to create weft curves and lines. If you can remember 1, 2, 4, 6, 8, etc., and including 'Jan's Law', your curve will be all right. Do not fluctuate once you have developed a sequence into a curve. For example, the following might be possible to create a good curve - 1, 1, 2, 2, 4, 4, 6, 8, etc. If you have to add another pass to make it work be certain to change between numbers, i.e., 1, 1, 2, 2, 2, 2, 4, 4, 4, 6, 6, 8, 8, etc.

(6) WARP SEQUENCES follow all rules of weft sequences EXCEPT that one should go sequentially 1, 2, 3, 5, 7, etc. When the warpwise curve is steep and there is warp distortion, use the double-weft interlock instead of long slits for the color changes.

(7) HATCHING-Fig. 5, is using single passes alternately of two colors to create shading and/or another color. 'Hatching' is the English word for the French 'hachure' when using one point of one color then one point of another color (or single passes alternately). At the Workshop, hatching is used only for the single hachure to clarify communication. See Fig. 5.

photo by Victor Budnik



Quartet-Movement III, 48" x 48" © 1980 by Evelyn B. Prosser

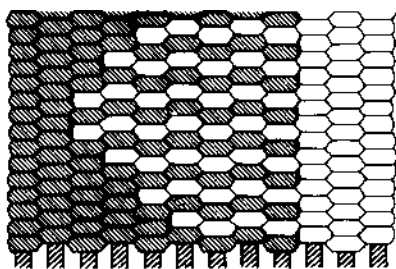

FIGURE 5. Hatching

(8) **HACHURE** is using several passes of each color to create a gradual transition, a shading and/or another color. See Figs. 6, 7, and 8 for three of the many possible ways of using hachures. When used very long (i.e. over twelve or more warp threads) hachures create extremely subtle changes. Hatching and hachures are the techniques unique to tapestry weaving and, from a design point of view, they separate the tapestry design from any design suitable for printing.

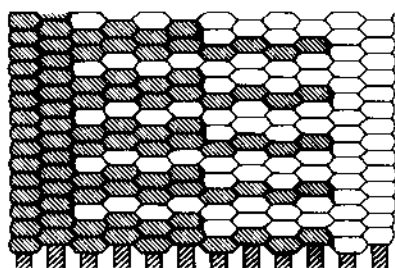

FIGURE 6. Hachure

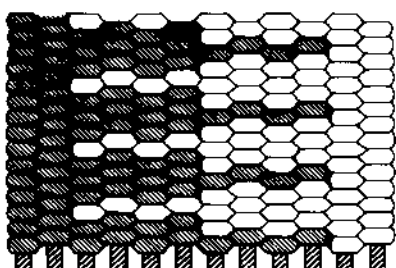

FIGURE 7. Hachure

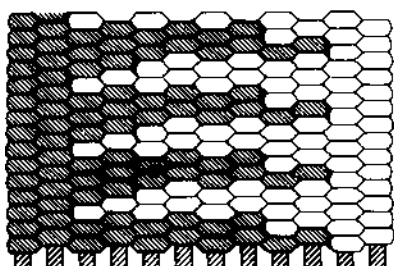

FIGURE 8. Hachure

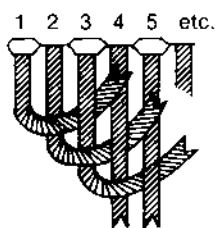

FIGURE 9. Finishing braid

In planning colors for a tapestry there are many possibilities of creating colors. Because several strands of wool are used at once to create the right balance between warp and weft to cover the warp, one can mix colors to create other colors.

(9) **STRAIGHT** colors means using several strands of the same color. When planning color in a tapestry it is important to incorporate some straight color in the design as rest places for the eye.

(10) **MELANGE** color is created when you take two or more colors to create another color. Each original color blends with the other(s) and together become an entire new color. If the melange color appears as a straight color when woven, this too becomes a rest place for the eye.

(11) **CHINE** color is obtained when two or more colors are mixed to create a third color but the original colors keep their own identity thus creating a variegated or dappled effect.

(12) When bobbins of color are wound, one does **NOT** **PLY** them as that creates a cord-like yarn. Thus, to keep the yarns as flat and as even as possible, the threads are wound onto the bobbin very tightly and flat.

(13) **FINGER BEATING** is used to put the yarn in place. In beating the yarn in with the fingers, be certain to put sufficient yarn in the shed so as not to spread or shrink the distance between the warp threads but so as to cover the warp (surround the warp). A comb is then used to flatten out the passes. One pulls the weft down. Beating with the comb is not necessary and gets tiring.

(14) **A HEADING** is woven at the beginning of the tapestry so that there is a woven place to sew on the cartoon. About $\frac{3}{4}$ inch (2 cm) is sufficient for a small tapestry. The larger the tapestry, the larger the heading, up to about 2 inches (5 cm). A heading of the same size is woven at the end of the tapestry also. These are eventually steam-pressed back and sewn to give the tapestry a finished look and to give strength to the sides of the tapestry. It is customary to weave an edition tag toward the bottom side (as it will hang on the wall) after the last hem is woven. It has its own hem to be sewn back. Be certain to weave it in far enough from the edge so that when it is on the wall the tag will not hang down and show at the bottom.

(15) **FINISHING** involves five procedures. First, all slits of about three or more passes should be sewn. A running stitch, picking up weft alternately from both sides of the slit, is used. Second, if there are loose weft threads that might work their way to the front of the tapestry through a slit, they are sewn back. Third, be certain to tack down all threads that might hang down below the bottom edge of the tapestry. Fourth, braid (see Fig. 9) warp fringes to secure them. Steam press the hems with a metal straightedge and a very wet tea towel over all to get a nice clean edge. After sewing down the hems, steam press the entire tapestry from the back only, to square and to flatten out any discrepancies. Fifth, sew a piece of pre-shrunk twill tape about 3" (7.5 cm) wide to the top back of the tapestry, leaving $\frac{3}{4}$ "-1" (2-2.5 cm) above the tape, or $\frac{1}{4}$ " (6.5 mm) plus the size of the screw eye. Staple this tape to a 2" x $\frac{1}{2}$ " (5 x 1.25 cm) board into which screw eyes can be attached for hanging.

SUPPLIES

Wool is the usual material used to weave the color of the tapestry. The San Francisco Tapestry Workshop uses Crewel yarn from Paterna. Several strands are used for each color depending on the portee used for the tapestry. Silk of the same size can be used to enhance areas. Metallics, handspun, and cotton are risky because they tend to pack down differently.

Cotton is used for the warp. Usually *Cum 12/12* is used for 13 portee because of strength and consistency of twist. When warping, no knots or other defects are allowed to be used in making a clear warp.

The Bobbins that are used are Aubusson (blunt or rounded ends) bobbins. They have holes running through them so they can go onto a bobbin winder.

The looms that are used at the San Francisco Tapestry Workshop are three varieties. They are all basically Aubusson low warp type looms. Jean Pierre Larochette designed a small upright loom with needles to be used by students. It is one lamme wide. A second high warp loom is used by advanced students. It too has treadles. As it was stated earlier in this article, this type of loom was developed for the Judy Chicago project and has since been used by advanced students and associates. It has the capacity of weaving a 63" (160 cm) square, or four lammes wide. There are, at present, three Aubusson low-warp looms at the Workshop, and they are used mostly for commissioned work. One (the original one built for the California Palace of the Legion of Honor Museum demonstration) is also 63", or four lammes wide. The other looms are size six and eight lammes wide respectively. Jean Pierre Larochette has built low warp looms for former students whom he feels are capable of doing their own work on that type of loom.

For anyone who has not done tapestry, one of the reasons for students to use the upright looms is so that the student weaver can go around to the front of the piece, in progress, to see if the interpretation of the design is satisfactory. As you see in Fig. 4 and in the description of 'Jan's Law', the front of the tapestry and the back can be quite different. Looking at the front tends to slow the weaver down. Also every time a new bobbin is needed to weave on the upright looms, the used bobbin must be secured so as not to unravel and the new one has to be unhitched to be used. This also slows down weaving time. In training to use the low warp loom, the weaver must then train him/herself not to look at the finished or front side of the tapestry. Hence it may take a year or more for a weaver to use the low warp loom with confidence. That is the main reason Aubusson looms are not available to weavers who have not studied the Aubusson low warp method.

Once can apply the technique of French Tapestry to other types of looms, but the tension devices must be very good and extremely strong. Very heavy canvas aprons should be put on back and front beams to aid in tension.

On the low warp loom the feet control the changing of the shed leaving the hands free to put the bobbins through the warp shed and to finger-beat the weft.

Combs are made specifically for pressing down the weft. They are made so that the teeth go between every other warp. Gratoires are small combs used when the fingernails can not be used, when pressing down, in a narrow area, or when working in a very large area.

CARTOONING

As in painting, calligraphy or drafting, tools and paints of the best quality are essential for the ease in working out a well defined cartoon. Acrylic, poster paint, or gouache can

be used. All are water soluble and the use of any of them depends on the artist's preference. Acrylic is good because it is waterproof after it dries and does not tend to chip or flake off.

A cartoon is a drawing to be used as the design for a tapestry, and is the same size as the tapestry. Therefore it should be well drawn. The lines between the colors should be well defined. Using French curves and other drafting tools when drawing can facilitate smoothness of lines as weaving very often exaggerates the flaws in the flowing lines.

Each person may develop his or her own method of cartooning but must keep in mind that when they are putting the final touches on the cartoon, the symbols and marks should be self-explanatory so that someone else could weave it without having to ask questions.

A tapestry is a monumental work. Therefore movement, balance, and plenty of contrast in color (light-dark, dull-bright) should be incorporated.

If the design is an interpretation of a picture, make a maquette, or rough painting, that is small and proportional to the finished tapestry. When blowing this up to the desired size, refine the lines and paint the colors as close to the wool colors as possible. Look at the areas of color and try to determine which areas should be straight color, melange, or chine. Also if there are areas suitable for hatching or hachure, mark those or paint those clearly on the cartoon so as to show how they are to be woven.

Color coding is extremely important. Paterna has its own color code and this can be used easily for areas of straight color. When a melange or chine mix occurs, make your own color code. Using number and/or letter sequences is possible. Or one can use, for example, T for turquoise and if there are six types of T make them T1, T2, T3, T4, T5, T6.

Try to preconceive all possibilities of color and technique and write down all the information beforehand. If there are details that have to be repeated, write down specifics at the time they are first done so that it can be done the same way the next time.

Cartoons can be fully painted with black lines carefully outlining the light colors and showing the color codes. White lines and white coding can be used for the dark areas. Or, cartoons can be black and white line drawings with all the appropriate coding made. The advantage of color cartoons is in seeing what approximate color you are to be working with. The advantage of blackline is that, if you have a colored maquette, you can concentrate on good weaving technique, on the work and the moment, not how far to go.

CONCLUSION

When comparing my personal experience in weaving tapestry in the Gobelin method and Scandinavian method, I find that French Tapestry designing and weaving by the Aubusson method, makes all the technique easier and clarifies the result. After more than three years of weaving Aubusson style, confidence, good train of thought, and insight into good teaching have resulted in a Workshop of merit. It is hoped that all who have viewed this article will visit, and perhaps study, at the San Francisco Tapestry Workshop.

© Evelyn B. Prosser

A SPECIAL ANDEAN TUBULAR TRIM-

WOVEN WITHOUT HEDDLES

by
**Adele Cahlander,
Ed Franquemont
and
Barbara Bergman**



Photo 1. A few Andean uses for "Tube 5": edge binding for coca bags and larger textiles; Tubular bands for belt ties and bag straps.

Of the many attractive embellishments used on textiles in the Andes, one of the most beautiful and intriguing is a diamond-patterned tubular weaving, with a "snake-back" effect due to its crossed and diverted warp threads. It is a favorite edge binding for large pieces and small bags, in several areas of Peru near Cuzco and Puno, and is more widely used in Bolivia, where the tube is also used separately for bag straps or pendants, and for ties at the ends of belts. (Photo 1).

Techniques for weaving this tube were first described in 1976 by Cason and Cahlander in their book on Bolivian weaving. It was identified as Tube 5, among five varieties of tubular edgings and trims. Two six-row examples were described, the first of which was based on a partly-woven specimen with a rather complex setup. It had a shed loop and three sets of string heddles, two of which had doups to aid in the crossings, but further manipulation was also needed. The second example had only one set of string heddles and shed loop.



Photo 2. Beside her fingers and toes, Victoria Paco needed only two sticks and a few yarns to teach Barbara the intricacies of weaving "Tube 5."

In 1978, more techniques for Tube 5 were published by Cahlander, with Cason and Houston, as an article for *The Weaver's Journal*, which became part of a monograph. A two-shed setup, with shed loop and one set of string heddles, was used for weaving several variations of the more-often-used 8-row version of Tube 5. Ways to have color changes in the tubes were also shown.

More recently, however, it has been discovered that some native weavers in the Andes use a simpler method without heddles. A key feature is the use of a "holding stick" to reserve a shed for a later row, thereby avoiding some extra manipulations. At Chicra, Pocoata, Bolivia, Barbara Heartwood Bergman learned how to make a short tubular band using a rod held between the weaver's toes (Photos 2 & 3). At Chinchero, Peru, Ed Franquemont learned how to make a long tubular edging for a large textile (over a yard (91 cm) square), in which the warp yarns were held in order by a *tanka* (small forked stick) holding the lease of the original warp cross (Photo 4). The methods will be described in detail. It is hoped that more evidence is being gathered, in the various places where Tube 5 is being produced.



Photo 4. Chinchero: To make a "Tube 5" edging all around a large manta, Benita Gutierrez needs long warps (15' to 20'). She keeps her yarns in order with a *tanka*, and also uses a holding stick for reserving sheds. Her weft is on a needle, so the edge is attached as it is woven.

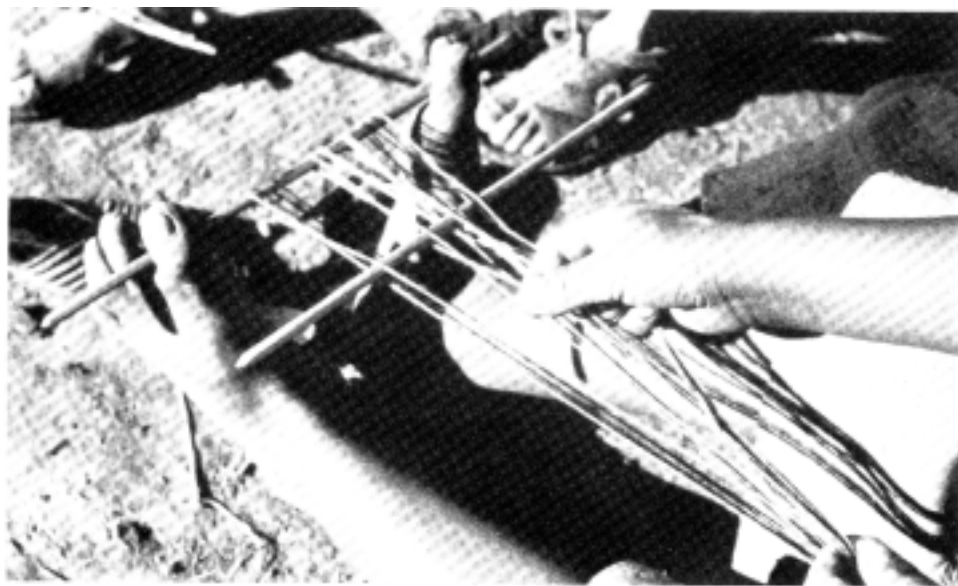

Photo 3. Chicra: Yarns are kept under tension by a stick held between the weaver's toes. Another stick is used to reserve a shed, to avoid unnecessary picking.

Some Andean Concepts. The Andean weaver never used written directions or patterns. She has learned by watching and doing, and proceeds according to certain concepts. Two Quechua names for Tube 5 have been reported: *ñawi awapa*, from Peru, by Ed Franquemont and Robin Woodhouse, and *awaq'ipa*, from Bolivia, by Donato Avendano. While *awapa* and *awa* refer merely to the fact that it is something woven, *q'ipa* is associated with the "sprouting of potato or corn of left-

overs at harvest", and according to Ed, *ñawi* ("eye") related to a Quechua concept of growth, a place where something generates—the eye of a potato, a spring of water, or a wild yeast starter. This pattern of small concentric diamonds has also been referred to in Spanish as *ojo de gato* ("cat's eye").

The warp threads in this tube are divided into those used for *listas*, the zigzag lengthwise stripes at the center and both sides, and those used only for the *ñawis*, which appear alternately at the right and left of the center *listas* (Photo 5). To guide her in her manipulations, the Andean weaver focuses on how the *ñawis* should open or close, in relation to the meandering *listas*. There is a special kind of symmetry involved, both sideways and lengthwise.

Variations. At least three colors of warp are used, one for the zigzag stripes and two for the diamonds, but more are usually used. The number of warp pairs for the *listas* may vary from two to seven. When the tube is to be used separately, rather than as an edging, the "side" warps will meet in the back, and the number of warp pairs for the center *listas* should be equal to the total used at the sides, for balance. When there is just a single center pair, there is a *lista* pair at only one side. There are also some differences in types of zigzags used.

THE METHOD AT CHINCHERO

During an extensive period of textile research west of Cuzco, at Chinchero, Ed learned how to weave the *ñawi awapa*. He was taught by 90-year-old Benita Quispe, in their customary non-verbal method. When Benita Gutierrez, one of the foremost weavers in Chinchero, was working on an edging for a large square *lliclla* (Photo 4), Ed made a study of the time involved. He reported that it took her 17 minutes to prepare the warp of 26 ends (13 pairs), with the help of another weaver. Its unwoven length was 17 feet, 8½ inches (5.4 m). Her first 16½ inches (42 cm) were woven in 65 minutes, at the rate of about 4 minutes per inch. Allowing for takeup, it then probably would take her about 12 hours of steady work to complete the job. She had begun at noon on the 8th, and brought it finished on the morning of the 10th.

Weaving Equipment. The lease of the original warp cross is held with a *tanka*, a forked stick made out of light wood that bends without breaking. It is taken from a branch that forks into two equal straight parts about ¼ inch (6.4 mm) in diameter. These legs are trimmed to be about 3" (76 mm) long and smooth, and the butt is trimmed as close as possible without weakening the joint of the crotch. Trimmings from it can usually be made into another tool, the holding stick, a smooth stick about 5 inches (12.7 cm) long. Benita keeps her holding stick tied to the *tanka* so that she won't lose time searching for it while weaving.

Warping. To determine the required length of the warp, the weaver runs a string around the perimeter of the cloth to be bordered, then adds the distance from her elbow to her knuckles to allow for take-up during weaving. Since the warp is generally quite long (15 to 20 feet or 4.6 to 6.6 m), a warping assistant is appreciated. Two spikes are set in the ground to provide the required length, and two more spikes are set near one end to define the original warp cross. Single yarns are wound as figure-8's in a sequence of colors. Benita used six colors, with six pairs of warp for the *ñawis*, seven pairs

for the *listas* (but these numbers can be varied). The *tanka* is entered in the warp cross, one leg on each side, as with lease sticks. The weaver pulls the two ends together and ties them tightly with a string, so the *tanka* cannot fall out. She also ties the far end-loops with a cord to hang from a spike or post. If she begins work immediately, almost twenty feet of warp may stretch before her, otherwise, most of the warp is wound around a stick and only five feet or so is exposed.

Process in General. On the near end, she attaches the end-loops to the cloth with several stitches, and passes a short, stout cord through the fabric just below the *awapa*. She ties this near cord to a belt at her waist for tension, holding the cloth to be edged in her lap. To make the edging tubular, the spiral weft is passed through the web in just one direction, and by means of the yarn needle on which it is threaded, it is put through the cloth on each "return trip". The weaver reverses the direction of the weft every few inches or so to keep the tube well centered on the edge. This shift is done by taking an extra stitch through the cloth.

The weaver must be careful to see that she maintains proper tension to avoid either gathering the cloth or distorting the pattern. Other considerations are proper spacing of the picks of weft, and suitable depth of the stitches along the edge. After she has woven about six inches (15 cm) the weaver advances the warp by putting the short cord through the fabric just behind the completed work, tying it to her belt; later, she moves it again as necessary until the edging is completed. The warp is unwound from the stick as needed.

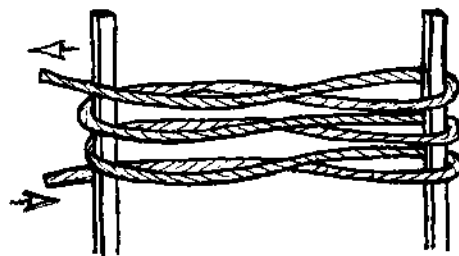

FIGURE 1, above. To wind the yarn in 2-bouts (figure-8's), start behind the left post.

To help you understand the method of weaving, the following instructions are provided, so you may learn by doing.

A FIRST SAMPLE

For your beginning sample, it is suggested that you prepare a short warp, about two feet (60 cm) long, and weave it as an edging on a small but firm piece of cloth, which you may need to fold to have enough body. You will need a needle with a large eye, and for weft, heavy sewing thread doubled, or something like Knit-Cro-Sheen or carpet warp.

Select four colors of yarn: white (W), light (L), medium (M), and dark (D). The L yarns will be used for the *listas*, and the other colors will be used to form the *ñawis* alternately on the right and left sides of the center *listas*.

Warping. Around two posts (about 2' apart), wind single yarns in figure-8's (s-bouts), starting each behind the left post (Fig. 1). Tie off each color at the left with a square knot, and cut ends to be about 1" (25 mm). Wind in this order:

1 s-bout L, 2 s-bouts D, 2 s-bouts L, 2 s-bouts W, 2 s-bouts M, 1 s-bout L. Tie a cord through the knotted loops at the left, then form a hanger-loop by tying the cord in a square knot. (Weaving will begin at the unknotted end-loops on the right after they have been attached to the cloth edge with a few stitches.)

Find the original warp cross, and insert a *tanka* or other short lease sticks, tying ends to make secure. (A rubber band may be twisted securely to the open ends of the *tanka*.) When viewed from above, the yarns in the lease should be in the order shown in Fig. 2.

FIGURE 2, below. Warp order on *tanka* (or lease sticks), when viewed from above. For convenience, the holding stick is attached with a cord.

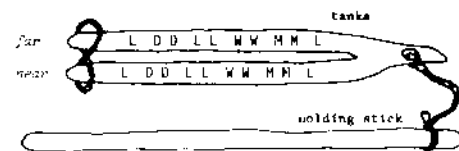

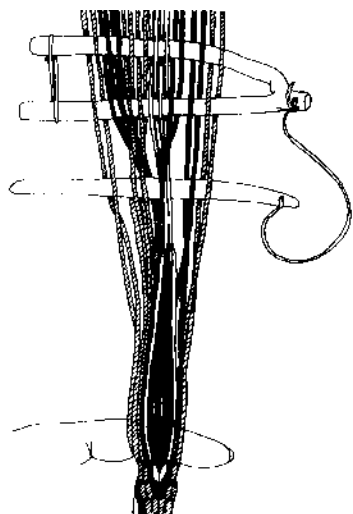

FIGURE 3. Position of yarns for row 3, centered of right *nawi*. The shed on the holding stick was used for row 2, and will be used again for row 4. Drawing by Sue Baizerman.

Weaving Sequence. Eight rows are needed for each repeat: A-B, C, B-A-B', C', B'. The A rows (1 & 5) are *khata* (have no crosses), and may be considered as "home base". They merely involve lifting all but the two **W** yarns from the top of the ROD, the near side of the lease. Beat, Pass weft, hold tension with left index finger.

For Row B, certain warps are crossed, and **W**'s are diverted. When the weft is passed, a **HOLDING STICK** is entered in the shed to reserve it for later use. Row C, the center of the *nawi*, is picked from those on the holding stick, with more crosses and diverted warps. (The four warps for the center are lifted in place last). For the following B row, the warps are merely lifted off the holding stick, with no picking needed. The next four rows are similar, but the *nawi* opens on the left instead of on the right.

Note that when the diamond on one side is opening, the one on the other side is closing, and that the lower yarns are being lifted on the sides of their partners *AWAY* from the opening diamond, and *TOWARD* the closing one.

The step-by-step instructions are based on the method learned by Ed in Chinchero. The areas of the opening *nawis* are indicated by strips of shading. Fig. 3 shows the position of the yarns when the shed for Row 3 has been picked (diamond opened at right).

Listas (marked with x's). In this example there are 3 pairs of **L** warps (1 at center, 1 at each side) to form the lengthwise zigzag stripes. Note that each pair is crossed or twisted (to left or to right) between the rows of wefts. After each D or C' row, the direction of twist is changed for each pair.

Nawis: Each has a center (a group of 4 yarns), an inner diamond (white interlacement) and an outer diamond, composed of countered zigzag lines, twisted like the listas, but for lower rows.

Diverted warps: The **W** warps for the inner diamonds float inside the tube from one diamond to the next. The 4 center warps of the first *nawi* (lower right) float inside the tube to be used for the outer diamond of the 2nd *nawi* (upper left) and conversely, the outer-diamond warps of the 1st *nawi* are used for the center of the 2nd one.

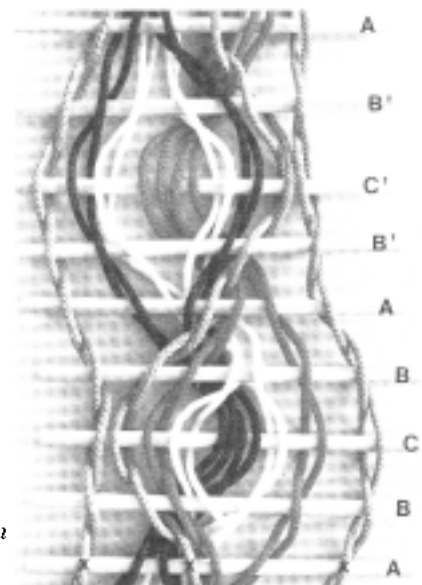
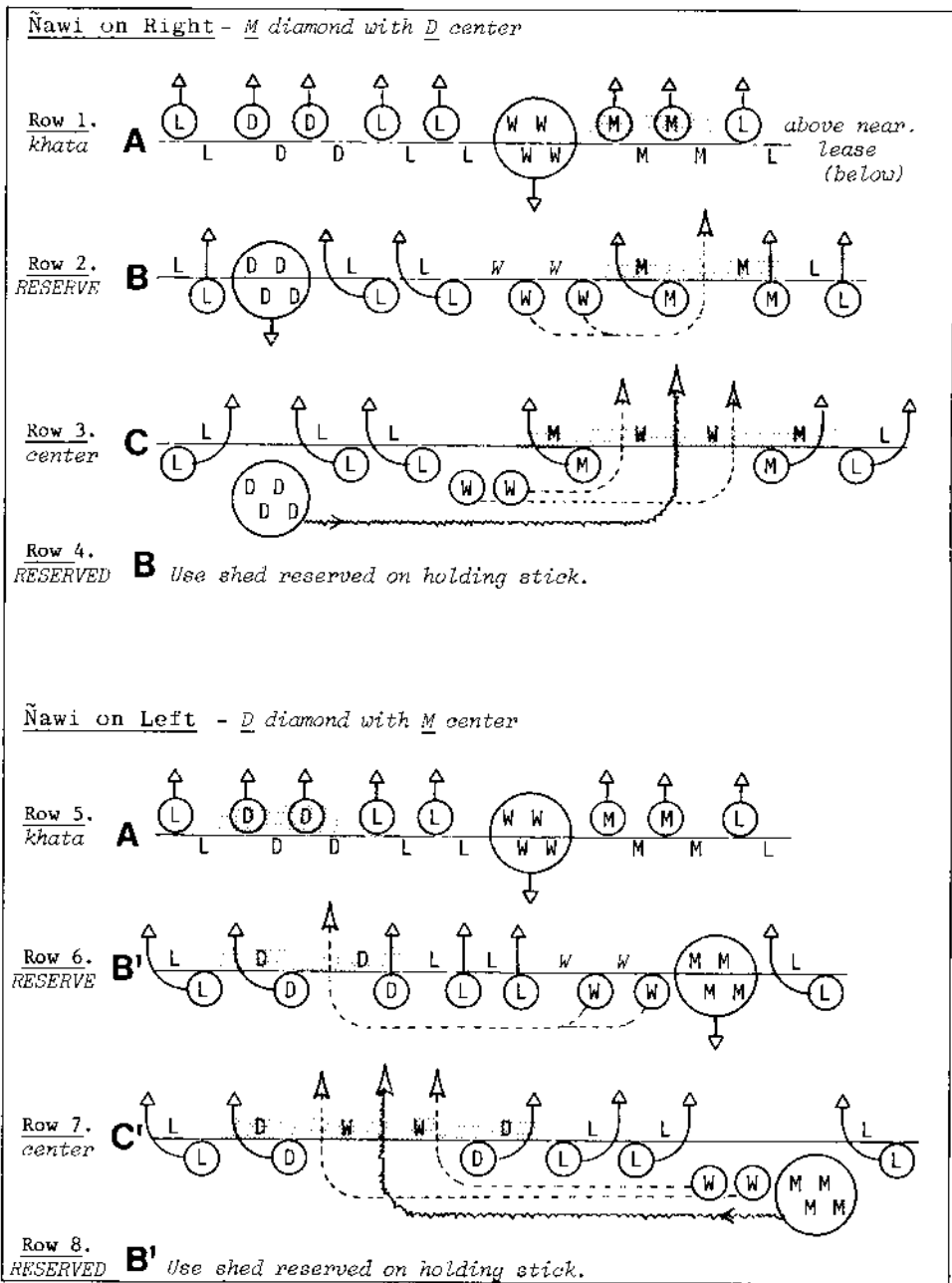

Photo 5. Diagrammatic construction of "Tube 5", with wooden sticks inserted in place of wefts. The letters relate to the weaving sequence.



THE METHOD AT CHICRA

The tube learned by Barbara during her day at Chicra is basically like the above sample, but it differed in the directions for some of the crossings. Also, rather than a long edging, Barbara learned how to produce a short separate example of Tube 5. Her teacher was a young woman, Victoria Paco V. (Photo 2).

Using only red, green and white, she wound loops of yarn from a stick held between her big toes, to her left index finger, without making a cross. She spaced the loops apart on the stick, arranging them: RGGR WW RGGR.

During weaving, the warp threads were held under tension with the left hand, sometimes by holding the woven part, but usually by having the left index finger in the shed. The right hand was used for beating, and for passing the weft under all the warp threads, then through the shed from left to right. The weft is pulled tightly in a diagonally upward direction; occasionally the woven end needs to be given a sharp twist toward the left to counteract its tendency to spiral. The sample warp you prepared may also be woven in this manner, as a free-standing tube. The ends may be finished in a short braid.

Bibliography

- 1976 Cason, Marjorie and Cahlander, Adele. *The Art of Bolivian Highland Weaving*. Watson-Guptill, New York, pp. 130-133.
- 1977 Rowe, Ann Pollard. *Warp-Patterned Weaves of the Andes*. The Textile Museum, Washington, D.C., pp. 110-111.
- 1978 Cahlander, Adele, with Cason, Marjorie & Houston, Ann. *The Weaver's Journal Monograph 1*. "Bolivian Tubular Edging and Crossed-Warp Techniques." Colorado Fiber Center, Boulder, pp. 12, 16-21.

Chicra Sequence: diamond on right

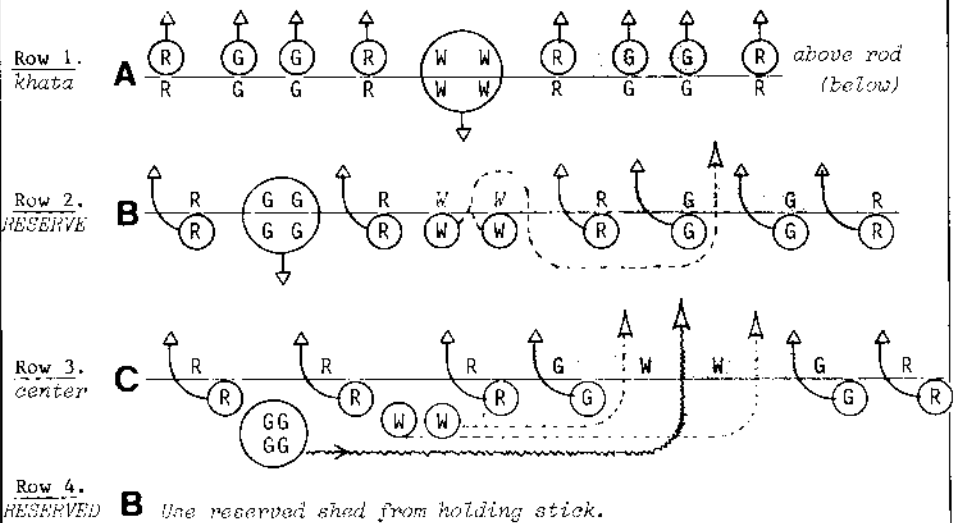

Chicra Sequence: diamond on left

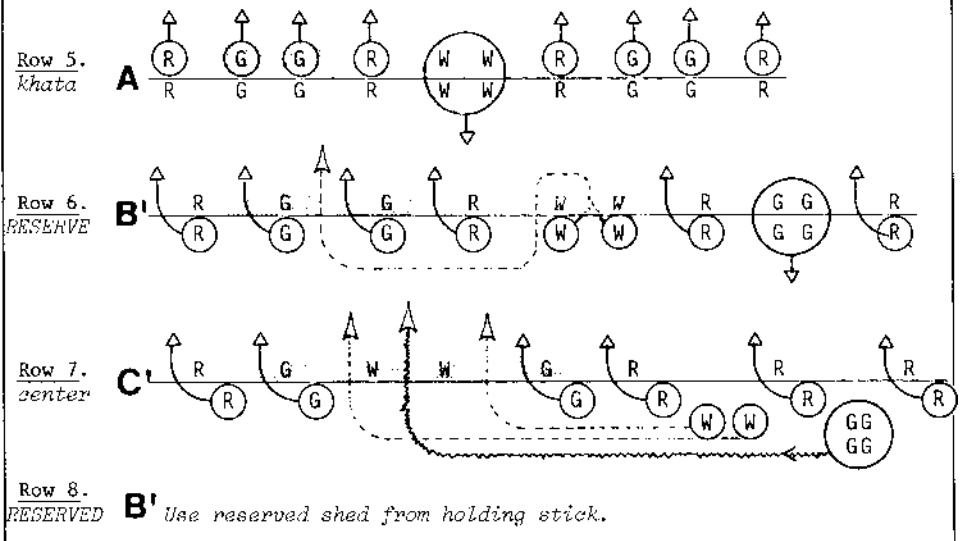

- 1981 Wasserman, Tamara and Hill, Jonathan. *Bolivian Indian Textiles: Traditional Designs and Costumes*. Dover Publications, New York, p. 9.

Handweaving With Robert and Roberta

A TRULY EXCELLENT HOME STUDY PROGRAM

STARTING WITH VOLUME ONE, THE FOUNDATION SERIES OF ASSIGNMENTS INCLUDING EQUIPMENT, DESIGNING, FIBER, COLOR, DRAFTING & BUSINESS **PLUS** ESPECIALLY PLANNED **WEAVING PROJECTS** TO BUILD YOUR FUNDAMENTAL WEAVING KNOWLEDGE AND SKILLS.

VOLUME TWO, THREE & FOUR CONTINUE STEP BY STEP TO HELP YOU PROGRESS FAR BEYOND THE MANY WEAVERS WHO HAVE FLOUNDERED YEAR AFTER YEAR.

WRITE FOR FREE DETAILS INCLUDING AN INDEX TO

AYOTTES' DESIGNERY, DEPT. WJ, CENTER SANDWICH, N.H. 03227



BOOK REVIEWS

by Clotilde Barrett

THE ART OF THE FELT MAKER by M. E. Burkett © 1979 M. E. Burkett, Abott Hall Kendal, Cumbria, England LA 9 5AL, 111 pp., paperbound £3 + postage (£4 airmail, £2 surface mail) ISBN 0-950-3335-14.

This book is a very informative and well-documented catalogue of a show "The Art of the Felt Maker" that toured Great Britain from mid '79 to mid '81.

The six introductory chapters tell a lot about felt making among Asian nomads. The author starts with a technical analysis of felting and the description of the preparation of unpatterned felt. The early history of felt is explored through archeological evidences and the earliest written sources. These chapters bring to light how these earliest of the man-made fabrics have been the means for great artistic expression besides being fundamental materials in the life of the people. There is evidence that felt was used for hats, shields, clothing, horse gear, boats, shelter, floor covering and wallhangings. For the nomads, felt was of magic and ritual significance and felt idols were objects of worship.

The authors' analysis of design elements gives a listing of the main methods of achieving them. This reveals the richness of the decorative potentials and is an inspiration for the contemporary felt maker. The last chapter is written by Verinika Gervees and deals with the making of felt coats.

The catalogue section of the book lists all the pieces in the show. Many items are illustrated with photographs, some in color. The items are listed by country: Iran, Afghanistan, Turkey, U.S.S.R., Iraq, India, Africa, Scandinavia and Britain. Each section is prefaced with a text on the felt making tradition of that country.

There are notes on dyes used in felt making and an extensive bibliography.

SALISH WEAVING by Paula Gustafson © 1980. Published in the U.S.A. by the University of Washington Press, Seattle, WA 98105 and in Canada by Douglas McIntyre Ltd., 1615 Venables St., Vancouver, British Columbia, 130 pp., \$24.95, hardcover, ISBN #0-88894-268-0.

This is a large format (8½" X 12"), expensive, beautifully illustrated and artfully produced book on one aspect of the arts and skills of North American Indians: Salish weaving.

The writing is addressed to the layman although scholars in the field as well as handweavers will probably be the first to

really delve into this book for new information on this relatively unknown cultural manifestation.

The author has gathered a large amount of data on historical events which might shed light on the development of the weaving skills of this Northwest Indian tribe. The historical events are narrated in a lively style which inspires an ever increasing fascination with the Salish people and their culture.

The photos account largely for the merit of the book; also an appendix listing all the known Salish blankets in Museum collections.

The technical descriptions of the weaving and spinning processes are rather superficial. For instance, the steps of spinning and plying are arbitrarily mixed up. There is no information on the twining techniques for patterns. Also, not every spinner would agree with the statement "canine hair, no matter from what breed, is not a good spinning fiber", an argument the author uses to support her theory that the existence of dog hair blankets is unlikely (what about the dog hair textiles found in the Mesa Verde, CO?).

The chapter on the attempts to revive the craft in the Fraser valley will probably give the efforts of these people a big boost which they have earned so well.

THE ART OF PAISLEY by Ed Rossback © 1980. Published by Van Nostrand Reinhold Co., 135 W. 50th St., New York, NY 10020, 128 pp., hardcover \$18.95 ISBN #0-442-24346-4.

In the early 1800's Paisley was already an established textile center in Scotland. It was at the time that the Cashmere shawls imported from India began to make great sensation in the fashion world of Europe. Paisley and other weaving centers in Europe adapted the idea of Cashmere shawls to the prevailing social and economic conditions of Europe at that time: taste for design, for fashion, and the available fiber and equipment.

The large colorful shawls with exotic design elements stayed in vogue for slightly over 50 years, but as Ed Rossback demonstrates in this exquisitely written and illustrated book, Paisley's shawls are textiles which are truly historical in their importance.

Everyone who picks up this book will be pleasantly surprised that a book like this, belonging to the broad class of textile history books, can be intensely captivating, witty and moving. All through the text the author reflects his deep human response toward these textiles.

The historical importance of Paisleys is captured in this quote from the book "Actually, Paisley's are transitional textiles, belonging to the world of the handmade that was dying and the world of the machinemade that was being born". This statement is underlying each one of the chapters, whether the author talks about the shawl and its role in fashion, social life or economy or whether he transports us to the town of Paisley, now and in the past. Ed Rossback, in this book, brings the 19th Century alive. The reader meets the weavers, shares their concern for the socio-economic changes which the highly mechanized looms are imposing on them. The reader admires the looms which are so ingeniously conceived that they can produce loom-controlled design of unbelievable intricacy.

The author dwells a great deal on design because the Paisleys reflect the attitudes of Europe in the 19th century and because these designs have a direct relation to the development of the textile industry.

Through this book "The Art of Paisley", Ed Rossback tells the story of the people in the Victorian era, the story of the weaver and his loom during the critical changeover in Scotland from handweaving to power weaving.

This is a book to be read and enjoyed by all.

WARP PAINTING: A Manual for Weavers by Dominic Nash © 1981. Published by The Unicorn, Box 645, Rockville, MD 20851. 33 pp., paperback \$4.95.

This is an excellent technical booklet. The text is concise and to the point and can easily be read through in a short time by anyone interested in the technique. The reader will be inspired by the variety of projects which have been achieved by means of warp painting and which are well illustrated through black and white photos.

The author gives clear instructions on how to get started (selection of fibers, selection of dyestuff) how to proceed (preparation of warp, preparation of loom, painting the warp) and finally the finishing process.

The properties of many commercially available dyestuffs are condensed in a valuable chart which, with the help of instructions supplied by the manufacturer for each type of dye, should provide the weaver with enough information on chemical dyes to use them successfully.

A bibliography and a list of supply sources add to the value of this useful manual.

THE WEAVING BOOK by Helene Bress © 1981. Published by Charles Scribner's Sons, NY, 548 pp., hardcover, \$50.00 ISBN #0-684-15664-4.

Certainly this book is bound to establish some records among the publications available to the handweaver. Its supersize of 548 pages (9½" height X 10½" width) bound in a somber black cloth cover will make it stand out (if not stick out) on any library shelf. Its heavy weight will assure that the book will never leave the handweaver's studio, which is the place where it really belongs. Its high price (although there are only 8 color pages) will make it affordable by only a few.

The book is luxuriously produced, carefully laid out and well illustrated with photographs of samples. It is a work of love and patience by weavers for weavers.

It is not exactly clear to what type of weavers or what level of skills the author addresses this book. Certainly Helene Bress must have had the hobbyist weaver in mind who is going to improve her/his skills by weaving off samples according to the directions in the book. The question is, at what level of technical knowledge should the weaver be in order to tackle this book? Beginners? The book starts easily enough with a nice chapter on plain weave. However, barely into the chapter of twills one reads "knowing that crackle weave is based on a series of point twills, has small overshots when treadled and that the A block always combines with the D block . . . etc". This seems to imply that the reader has a thorough understanding of crackle weave and knows what overshoot means before using this book. Neither subsequent chapters, the glossary nor the index will explain to readers what this somewhat controversial crackle weave is.

Is the book for advanced weavers? With 110 pages on huck alone, any weaver is likely to discover in this book something on huck threading that she/he hasn't woven yet but on the other hand the style throughout the book of teaching cloth structures by giving recipes to weave off samples is not really geared to the weaver with technical skills.

Intermediate weavers may find the book very useful and enjoy the author's personal style of writing and of presenting a weaving course. In the entire book she deals with only 4 types of threadings: Plain, twill, overshoot, with one chapter devoted to opposite overshoot and huck. For each of these the author explores the classic structure and all the weave structures that can be obtained by using various treadling systems. These treadling systems are mostly derived from classes of weaves which are not dealt with in the book (Bronson, Summer and Winter, etc.). It is fun to have a warp on the loom and weave off batches of different samples each with a different visual and tactile impact.

For the 4 families of threadings which are

explored in this book there couldn't be a better guide for this type of weaving. The instructions are detailed, the photos show what should be accomplished and the style of writing will spur you on as if an old weaving friend was standing by.

TEXTILE HISTORY, Vol. 10, 1979; Vol 11, 1980. Editors K. G. Pointing and S. D. Chapman © 1979 & 1980. Published by The Pasold Research Fund Ltd, 23 St. James Square, Bath, England, about 240 pp. per issue, paperbound.

Each issue of this serial contains a dozen or so different contributions by experts in various fields of textile history. Many pages (30 to 40) are devoted to book reviews. Some of the titles of the articles in the 1979 issue read as follows: The Industrialization of Linen and Cotton in Germany in 1850; The Lacemakers of Valenciennes in the 18th Century; Fulling in the West Riding Woollen Cloth Industry 1689-1770; New Data on Islamic Textiles from Genzia.

Emphasis in most of these articles is on the social and economic aspects of the early textile industry as well as on scientific accuracy in putting textiles in historical and geographical perspective. Each article is heavily footnoted for sources of information and has an extensive bibliography. This is excellent reference material for the scholar interested in any or all of the subjects which are dealt with.

Although the 1979 volume has many contributions related to the cotton, linen and woolen industry in Europe between 1650 and 1850, the 1980 volume has a stronger and more unified theme: African textiles. Titles read as follows: An Introduction to Traditional African Weaving and Textiles; Cloth as Money: the Cloth Strip Currency of Africa; Onnang Igidio Raphia Weaving; The Classification and Distribution of Horizontal Treadle Looms in sub-Saharan Africa; and more.

The information contained in these articles is very valuable to the textile researcher. New technical information is uncovered, there is new awareness of the skills and creativity of ethnic groups, new inspiration for the contemporary weaver, and new documentation which sets the craft of the textile artist in historical perspective.

The book reviews in these serials are of great value too. Most of the book titles would remain completely unknown to the textile craftsman because the authors, publishers, and textile institutions seem to form a closed circle of communication into which the craftsperson has a hard time penetrating.

As all the articles in these books will not be of equal value to each person and to each region or time, I strongly suggest that everyone urge their library to consider subscribing to this informative serial so that it will be available for reference and study

BOLIVIAN INDIAN TEXTILES—Traditional Designs and Costumes by Tamara E. Wasserman and Johathan Hill © 1981. Published by Dover Publications, Inc., 180 Varick St., New York, NY 10014. 56 pp. paperbound \$7.95, ISBN #0-486-24118-1

The authors have researched the traditional Bolivian style of dress from the earliest known archaeological documentation. They have also studied Inca clothing which was documented by the Spaniards upon their arrival in the New World. Inca garments are the prototype of several of the costumes still woven today.

History and religion have caused styles to change and symbols to acquire new meanings but Bolivian weavers still follow traditions and have proven themselves through the years to be master weavers with great sensitivity to design. However these high skills have been threatened by today's economic factors. It is therefore timely that a book is published illustrating the beautiful costumes of Bolivia and the highly perfected weaving skills of these people.

Splendid examples have been captured in 32 full color plates and many excellent black and white photographs. Each plate shows several textiles, each of which is documented through descriptive captions which will be of great value to the collector and the weaver interested in South American techniques.

The introduction to this collection of fine photographs deals with history and religion, with the meaning of design motifs, with the weaving (training, materials, methods) and with the regional weaving centers and differences in costumes.

Well worth the price!

RUG WEAVING, Technique and Design by Brian Knight © 1980. Published by B. T. Batsford Ltd, 4 Fitzhardinge St, London W1H 0AH or North Pomfret, Vermont 05053, 144 pp., hardcover, \$19.95 ISBN 0-713-42582-2.

The techniques explored in this book are, for the most part, based on plain weave. They are suitable for a floor loom and for a frame loom. The book is geared to beginners but weavers of all levels should find some new and useful information such as dip-dyeing and tie-dyeing for weft face cloth, a good chapter on yarn counts and suggestion for weaving with fibers other than wool.

Before going into the subject of rug weaving the author dwells for a long time on weaving equipment. There are several plans for the construction of frame looms with and without tensioning devices. As to the floor loom and warping, the information is basically a repetition of what is found in any basic weaving manual. These introductory chapters account for more than one third of the book. Too much in my opinion.

Chapter 6 "Beginning to weave" is the first of several which are directly concerned with weaving rugs: Plain weave, pile rugs (rya), twisted weft, 2 or more shuttle weaves, tie-dye and dip-dye wefts, elementary tapestry techniques, soumak, warp face rugs, weft fibers other than wool and a few finishing techniques.

The information in the entire book is meager compared to Peter Collingwood's book on rug techniques but a beginner might feel more comfortable with this one. There are lots of large drawings illustrating the techniques. The photos of woven samples and rugs are adequate to show techniques but not designs.

WEAVE IT! 28 Projects for Your Home by Marilyn Meltzer © 1981 Van Nostrand Reinhold Co. 96 pp., hardcover, \$14.95 ISBN 0-422-25326-5.

This is a project book in which step by step instructions are given for functional and decorative items for the home.

The introductory chapters with general directions and a description of basic weaves serves as a quick reference for technical information. Although the book is clearly written and well illustrated, I must complain once more that X's are used instead of O's for the tie-ups of rising shed looms. Also, when paddle warping is suggested for a project, the reader will find what a paddle is but not how to use it.

I also want to raise some questions about the accuracy of the projects. I seriously doubt that an 8-shaft waffle-weave afghan of which the finished size is 40" X 60" can be woven on a 42" loom. Only 5% take-up and shrinkage!

The instructions for finishing fabrics are inadequate. If they are given at all they are very limited and mostly restricted to steam press or dry clean, even for a cotton blanket.

Nevertheless, the projects are very interesting and varied. They include such items as covers for captain chairs, window shades, screens, wallhangings, a swing, a showercurtain, stair tread covers, rugs, placemats, a hammock and lampshades. The suggestions and the ideas will certainly inspire the reader; therein lies the merit of the book.

The detailed instructions will give the beginner a degree of security to accomplish a handsome project.

BOOKNOTES

The Weaver's Journal received this quarter several small booklets inexpensively produced, but with good information on the subjects they cover. All are worth looking into, especially for teaching and workshop situations or for quick reference.

INSTANT INTERIORS mailed us a series of small publications that could prove to be very useful for the handweaver. The booklets have 6 to 8 pages each and deal with the following subjects: Bed Covers, Easiest Furniture Covers, Fabricating Everything, Fabric Spacemakers, Table Toppings. Send inquiries to P.O. Box 1793, Eugene, OR 97440.

These booklets contain a wealth of information on pattern matching, yardage calculation, construction of window coverings and much more. They are especially valuable for the weaver specializing in weaving for the interior. They are a good source of new ideas.

WEAVES AND TECHNIQUES FOR THE INKLE LOOM by Betty Atwood © 1972, Published by Betty Atwood Handweaving, RFD # Hillcrest Rd., Shelburne, VT 05482, \$7.50 + \$1.00 P & H.

This basic text on inkle weaving shows many techniques with several yarn and color combinations. What makes the '81 version specially attractive are the woven swatches which have been added to the previous printings and which document each technique in a lively colorful way.

THE HANDWEAVER'S STUDIO MONOGRAPH SERIES: #2-Double Cloth (on 4-shaft loom); #3-Loom Mechanics; #4-Yarn Counts; #5-Double Pocket Cloth; #6-Double Faced Fabric (#1-is on spinning but was not received). Printed and published by: The Handweavers Studio and Gallery Ltd, London. Available from Syd Gelbwaks, Simply Natural, Hermon, N.Y., 13652.

These booklets are contributions by various authors. Each one is clearly written and well illustrated and contains interesting material on its subjects which is hard to find in other publications. "Loom Mechanics" is especially valuable for weavers with counterbalance or counterbalance looms. All booklets are limited to 4-shaft weaves.

WELCOME TO THE WORLD OF NATURAL COLOR by Barbara Ann Dick © 1981. Published by Fleece & the Unicorn, Rte 5, Box 368, Stillwater, OK 74074, \$2.00.

An easy to use simplified little manual on natural dyes. Plenty of information to get started on this fascinating craft. It is excellent for self-teaching or for dyeing "bees".

ORDER ALL YOUR WEAVING, SPINNING, DYEING BOOKS AT DISCOUNT

Any good, standard Classics and many New Titles
Also Needlework, Hobbies, Crafts, Dolls, Miniatures
10% discount on any U.S. books

KATHERINE RAMUS 2100 E. EASTMAN AVE., ENGLEWOOD, CO 80110

March 8 - April 9, 1982

A series of spring one week workshops for students of all ability levels and media interests.



Pi Beta Phi

ARROWMONT
School of Arts and Crafts

Box 567 Gatlinburg, Tennessee 37738 (615) 436 5860

Ceramics, Weaving, Basketry,
Fabric, Soft Sculpture, Stitchery,
Enameling, Metalsmithing,
Stained Glass, Leather, Paper-
making, Painting, Photography

Summer 1-2 week sessions
June 7-August 13, 1982

PRODUCT REVIEWS

CREATEX

Color Craft Ltd. Offers several "Createx" products: Poster Colors for fabric, Textile Pigments, and Liquid Fiber Reactive Dyes. Of special interest to the weaver are the Liquid Fiber Reactive Dyes. They are concentrated dyes used in the same manner as Procion powders. The manufacturer claims that, since they are in liquid form, there are no irritating powders and dust, the need for a face mask is eliminated, ventilation is not as much of a problem, allergic reactions are lessened, and liquid colors are more easily handled and measured than powders which vary in weight from color to color.

This product is offered for dyeing and printing. Appropriate uses include yarn dyeing, batik, tie-dye, hand painting, silk screen, stenciling, air-brushing, block printing, and dip-dyeing.

I conducted dye tests on both wool and cotton using the corresponding directions for each fiber. Dyeing wool took less time and had fewer steps than working with cotton (about 1½ hours for wool and 3 hours for cotton). Directions were straightforward and easy to follow. All tests were done according to the page of directions which came with the samples.

My results with wool dye tests were quite good, except for black. BLUE turned out to be almost navy, YELLOW was an excellent sunshine yellow, RED was a beautiful magenta, and BLACK a grey-blue. Wool colors were bright and vibrant except for black.

The cotton dye tests that I did were lighter, duller shades of color (almost pastel). Again, black was a failure.

In both tests the BLACK looked dark navy in the dyebath, but a great deal of dye rinsed out during the after-treatment procedure.

Penetration of dyes in both fibers was excellent and very even. Wash fastness seemed fine in testing after the yarns had fully dried.

Cost of the product is as follows: (blue is more expensive with the prices in parenthesis) 4 oz - \$2.70 (\$3.60), 8 oz - \$4.35 (\$5.90), 16 oz - \$6.50 (\$8.90), 32 oz - \$10.90 (\$15.90), Gal - \$38 (\$53). 1/3 oz dyes 1 lb. of wool to a medium shade. Prices are for 1-5 units; more units ordered brings down the price. A sample kit is available for \$12. The kit includes 4-oz samples of BLUE, YELLOW, RED, and BLACK dyes plus a number of chemicals. The instruction booklet costs 75¢.

After my research I feel it is imperative to follow directions carefully for best results. Sample testing should be done to see color results for individual fibers. Notes for future reference, and yarn samples before dyeing

and after dyeing, are helpful. I do wonder if special procedures for black might aid in getting better results? The product was easy to handle and measure. Because of health hazards I would prefer to use liquid dyes rather than mix up powdered dyes.

The address for Color Craft Ltd. is P.O. Box 936, Avon, CT 06001. (Phone (203) 658-1476)

Chris Switzer

COMPUTER LOOM (Update)

Computer Loom 6.0.0. is really one of three Apple II programs for simulation and analysis of weaving that are supplied on a single 5¼" DOS 3.2 diskette by Tim Trudel, 1001 S. Washington Ave., Fullerton, CA 92632. Price is \$30.00; telephone inquiries may be made by calling (714) 870-1916.

An earlier version of Computer Loom was reviewed in *The Weaver's Journal*, Vol. VI, No. 1 (Summer 1981), p. 34. The comments made there remain valid, except that the two weak points have been eliminated in the latest version. Provision is now made for saving the drawdown on the disk if desired. More importantly, the color (black or white) of each warp thread and weft pick are now selectable by the user, so that any desired two-color effect can be obtained. The only slight shortcoming that remains is that the program as furnished requires the use of the Apple Silentyper printer, which, because it is a thermal printer, cannot produce printouts of archival quality. Because the program uses almost every byte of a 48K RAM, it can be a problem to convert it for other printers unless the graphics screen-dump routine is in firmware. We were successful in adapting the program for the IDS-460 Paper Tiger, but only by time-sharing a block of memory with one of the program's machine-language subroutines.

The second program in the package, Color Weaver, is essentially the same program modified to use the Apple's low-resolution graphics display. This reduces the number of warp threads and weft shots to 40 each, but permits the use of any of the 16 low-resolution colors for any warp or weft thread, thereby permitting multiple color effects. The graphics display is the same as that generated by Bruce Bohannon's Weaver program (cf. Barrett, C. "Computer Weaving", *The Weaver's Journal*, Vol. IV, No. 3, pp. 35-39, January 1980). The two programs really differ only in the protocols for entering data (threading, tie-up and treadling) and transferring information to and from the disk. Each program has some features in this area that are not present in the other.

The third program in this package, Block Analysis, allows the user to sketch a low-resolution graphics design on the screen by moving a cursor block under keyboard control. When the sketch is complete, the program prints out the sequence of threading blocks and the treadling blocks required to produce the design. The design and the block analysis may be printed as desired. In this case, the design is printed in pseudo-graphics, i.e. as X's and spaces, so no problem arises with screen-dump routines.

We have to find fault with one bit of terminology used in the program output, namely, the use of the word "pick" for the vertical subdivisions of the design structure. These subdivisions are actually *treadling blocks* and usually involve multiple weft picks. Also, an experienced designer using a sheet of graph paper could probably win a race with an inexperienced user of this program in producing and analyzing a design. This is because sketching of the design using keyboard cursor moves is very slow until one has practised a lot.

In summary, we believe that this package of utility programs for weaving simulation and analysis is a very worthwhile investment for Apple-owning textile designers.

Earl Barrett

THE DYER'S BOOK (Cushing Dyes)

The Dyer's Book compiled by Carol Kampert and Sue Henrikson is a complete study of the Cushing Dyes. It is published by Mountain Fiber Studio, \$50.00 plus \$2.50 S+H.

Cushing dyes are among the finest, best and easiest to use union dyes (or all purpose dyes) on the market today. These dyes cover a wide range of color and their "ordinary type" is well suited for cotton, silk, wool, linen and rayon. Carol Kampert and Sue Henrikson have taken skeins of these five fibers, dyed them with 83 different Cushing Dyes and neatly arranged these yarn swatches into a beautiful catalogue matching up each dye with the samples.

The Dyer's book is also an instruction book. You will learn about equipment and record keeping, how to prepare the fibers, and the procedure for correct and successful dyeing. There is also a section on the characteristics of fibers and a useful glossary.

Retail shops carrying Cushing Dyes will find the book to be an important sales aid.

Clotilde Barrett

PRODUCT NEWS

Herald Looms, 118 Lee Street, Lodi, OH 44254, announces two new products:

WARPING BOARD - 23" X 37" (58 X 94 cm) when assembled, makes up to 12 yards (11 meters) of warp. It is completely collapsible for easy storing and shipping. The assembly is very simple.

DOUBLE WARP BEAM BRAKING SYSTEM - Herald Looms has made a change in the design of the braking system for looms with two warp beams. The system works for all sizes of Herald Looms and can be installed by weavers who already own Herald Looms either with single or double beams. The rope and pulley of the old system is now replaced by a clutch which allows the tension to be regulated with great precision.

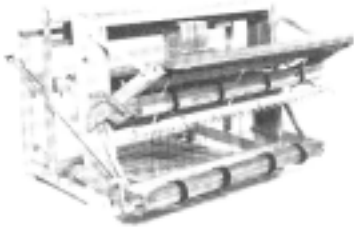

Dyeworks, 312 So. 3rd St., Minneapolis, MN 55415, announce that they are wholesale and mail-order outlet for quality natural-dyed yarns.

NATURAL DYED SILK AND WOOL - Dyeworks' inventory features a wide variety of silk and wool yarns in over 40 different colors. Samples are available upon request. Special colors may be custom ordered. All finished yarns are prewashed and guaranteed color and light fast. Dyeworks can also supply undyed yarns, bulk dyes, and special soaps and will manufacture sweaters and yardage to order.

Beka Inc., 1648 Grand Ave., St Paul, MN 55105, has in 1981 added quite a few new products to their loom, book and equipment list.

SRL LOOM SERIES - A rigid heddle floor model loom for which the stand may be purchased separately. Each loom is furnished with all the basic weaving accessories including three rigid heddles (8 dent, 10 dent, 12 dent). The looms come in widths of 36", 40", 44" (91, 102, 112 cm). A second warp beam is optional.

School Products Co. Inc., 1201 Broadway, New York, NY 10001, announces that it is the U.S. distributor and importer of the New Zealand Camelot Wheel.

CAMELOT is a castle wheel, beautifully designed and finished and very popular among Australian and New Zealand spinners. The good-sized orifice makes it possible to spin a variety of thicknesses of yarn. The tensioning devices are engineered to adjust to the spinners' own needs. The wheel is compact in size and is easy to carry.

A **SPINNING CHAIR** is a desirable accessory for the comfort of the spinner.

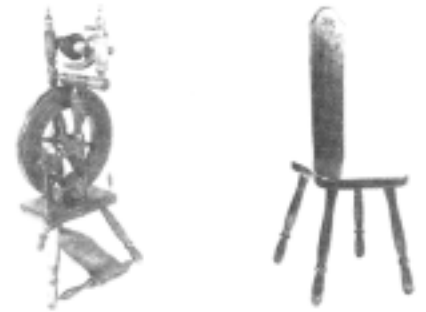

COMING EVENTS

ARIZONA

Tempe, Feb. 8-27, 1982. Telerana Weavers and Spinners 2nd Annual Juried Show. Mesa Activities Center Gallery, 144 North Center, Mesa, AZ.

Sedona, Sept. 1981-Feb. 1982. Workshops. Quilting with Mary Lucas, San Francisco; Beginning and Advanced Handweaving with Mary Pendleton, P.O. Box 233, Sedona, AZ 86336.

CALIFORNIA

Sacramento, May 1-2, 1982. 29th Annual Conference of Northern California Handweavers. Theme - "Festival of Fibers." Convention Center, 14th & J Streets.

COLORADO

Alamosa, March 29-April 4, 1982. Workshop by Clotilde Barrett on loom controlled rugs and tapestries. College credit. Send inquiries to: Art Dept., Adams State College, Alamosa, CO 81102.

Denver, March 29-April 16, 1982. Innovations in Fibre II: A national juried fiber exhibition open to all fiber related mediums. Entry deadline, Feb. 12, 1982. Sponsored by Skyloom Fibres in co-operation with Denver's Boettcher Concert Hall and The First of Denver Bank. For information send SASE to: Skyloom Fibres, 1905 South Pearl, Denver, CO 80210.

Durango, July 14-19 1983. Intermountain Weaver's Conference on the campus of The Lewis College. Workshops, Seminars, Demonstrations, Commercial Exhibits. For information send SASE to: Lois Self, 8550 E. Cuin Pl., Tucson, AZ 85710.

MASSACHUSETTS

Boston, Artists in Residence Series. Barbara Shawcroft, Slide lecture: Recent work. Feb. 24, 1982; Ed Rossbach, Slide lecture: The Change in Fiberwork. Apr. 14, 1982; Katherine Westphal, Slide lecture: Non-Corporate Textiles: Figurative Fiber Art. Apr. 15, 1982. Morse Auditorium Lecture Hall B1, Boston University, 602 Commonwealth Ave., Boston, MA 02215.

NEW MEXICO

Albuquerque, Feb. 26-27, 1982. New Mexico State Spinners and Weavers Conference. Hosted by Las Aranas Spinners and Weavers Guild, P.O. Box 26954, Albuquerque, NM 87125. Exhibits. Workshops. Commercial exhibits. Regent Hotel, Albuquerque Convention Center.

NORTH CAROLINA

Chapel Hill, March 13-28, 1982. The Tenth Annual Festival of Weaving, sponsored by the Triangle Weavers and the Chapel Hill Handweaver's Guild. Non-juried exhibition of woven pieces from tapestries to clothing. Educational displays. Weaving and spinning demonstrations daily. Horace Williams House, Chapel Hill.

PENNSYLVANIA

East Berlin, April 10 - May 2, 1982. Annual Handweaving Show for handweavers and fiberists from United States and Canada. Categories include traditional weaving; handspun, hand dyed and handwoven; handwoven rugs; weaving you can wear; tapestry; weaving for home interiors; fiber manipulation. Send inquiries to The Mannings, R.D. 2, East Berlin, PA 17316.

TENNESSEE

Memphis, March 1982. Tennessee Artist-Craftsmen's Assoc. sponsoring juried exhibit of fine crafts. Residents of Tennessee eligible to enter slides by Jan. 8, 1982. For prospectus write to: University Gallery, Memphis State University, Memphis, TN 38152.

WASHINGTON

Seattle, July 15-18 1982. Convergence '82. Biennial meeting of the Handweavers Guild of America. Four day fiber extravaganza preceded and followed by workshops.

CANADA

Ottawa, Ontario, On Tour: Guelph Art Gallery Jan. 16-Feb. 14, 1982; Norman MacKenzie Art Gallery, Regina Mar. 6-May 24, 1982; Confederation Centre Art Gallery, Charlottetown, P.E.I. (tentative) June 19-July 18, 1982. The exhibition *The Comfortable Arts: Traditional Spinning and Weaving in Canada*. Assembled by Dorothy Burnham. Textiles, spinning wheels and other textile equipment, graphs, publications.

THE WEAVER'S MARKET-CLASSIFIED

PUBLICATIONS

THE DYERS' BOOK by Kampert and Henrikson. Wool, silk, cotton, linen, viscose-rayon yarns dyed in 83 Cushing colors (420 samples). Text includes: dyeing procedures and tips, fiber preparation and care. 8½ x 11" card stock. 26 pages. 3-ring binder. \$50.00 (+ \$2.50 shipping and handling). Send check or inquiry to: MOUNTAIN FIBER STUDIO, 3060 Ash Avenue, Box WJ, Boulder, CO 80303.

A RAINBOW IN YOUR HANDS by Mary Ann Miller. Unique, exciting, different methods using all-purpose dyes. Complete book contains 253 samples dyed with 52 Cushings' colors. \$22.50. Text alone \$13.95. Add \$2 for 1st class. FLEXIBLE FIBRES, P.O. Box 34013, Omaha, NE 68134.

WARP WITH A PADDLE - BEAM WITHOUT PAPER by Lucille Landis. An adaptation of industrial procedures for quality warps. Quickly wind 24 or more threads at once—any combination of yarns, textures or colors. Beam whole warps without paper or similar support material—with an assistant for very long, wide warps. Otherwise, beam alone, with or without paper. 45 B&W detailed photos, 35 pages, soft cover, \$6.50. Add 7% Sales Tax in Connecticut. Postage \$1.50. \$35 additional copy. Dealer inquiries invited. BOOK BARN, P.O. Box 256, Avon, CT 06001.

WEAVES AND TECHNIQUES FOR THE INKLE LOOM by Betty Atwood. 1972 publication now including actual swatches of all 8 patterns plus supplementary information. Price \$7.50 plus \$1.00 for postage and handling. Send check or money order to BETTY ATWOOD, RFD No. 2, Box 2290, Shelburne, VT 05482.

HAMMOCK MAKING TECHNIQUES. All you need to know to design and make your own woven, twined, linked, looped, knotted or sprang hammock. Paperback, 80 pages. \$7.50 + \$1.10 shipping. PENELOPE DROOKER, RFD, 1, Sanbornville, NH 03872.

PATTERN DEVICES FOR HANDWEAVERS—125 pages, illustrated: Practical information on mechanisms ranging from pick-up sticks to drawlooms, effective loom modifications, and instructions for damask, double weave, warp pattern, weft pattern. \$18.00 plus \$2.00 shipping. (MD residents add .90 tax.) DORAMAY KEASBEY, 5031 Alta Vista Rd. Bethesda, MD 20814.

TRS 80 PROGRAM for automated draw-downs. Up to 8H/10 Tr/116 threads. Screen display shows all features of standard draw-downs. Complete freedom of choice for tie-up, treadling sequences, thread-by-thread and/or profile drafts. B/W color sequences for warp and/or weft. For Model 1, Level II, 16K and/or Model III, 16K. On cassette with complete instructions \$35.00 W. SALSBURY ASSOCIATES, INC., 608 Madam Moore's Lane, New Bern, NC 28560.

YARNS, FIBERS AND FLEECE

YARNS/SCHOOL PACK ASSORTMENTS: 100% Cotton Novelties: Lace, Seeds, Flackes, Nubs & Slubs; 100% Mercerized & Carded cotton; 100% shetland; Wool Blends (70/10); Linen; Viscose/Silk Blends; Natural & Colors Rayon Chenille; Rayon Novelties (840 yds.-6,600 yds./lb.) 50 lbs.-\$2.25; 100 lbs.-\$2.00; 250 lbs.-\$1.75; 500 lbs. \$1.50; 1000 lbs.-\$1.15. Freight Not Included. Prepayment with Order: SILK CITY FIBERS, 155 Oxford St., Paterson, NJ 07522 201 942-1100.

MOHAIR LOOP - 11 colors. Brushes up well. Also some camel hair and alpaca. Send SASE for samples. CUSTOM HANDWEAVING BY NANCY, DEPT. WJ, P.O. Box 477, Redondo Beach, CA 90277.

SHEEPSKIN PIECES - Finest quality cleaned skins. Random sizes. Make rugs, vests, purses, & seatcovers. Free instructions with order. One lb.-\$4.00, 5 lbs.-\$16.00, 10 lbs.-\$28.00. Plus shipping. CUSTOM HANDWEAVING BY NANCY, Dept. WJ, P.O. Box 477, Redondo Beach, CA 90277.

SILK-TUSSAH - 7 colors & Douppioni - 8 colors \$28/lb. While supply lasts. Samples \$3.00. Sorry Tram ALL sold. CUSTOM HANDWEAVING BY NANCY, Dept. WJ, P.O. Box 477, Redondo Beach, CA 90277.

NEW ZEALAND: Famous for Beautiful Wool! Top quality fleece or carded Merino, Corriedale, Perendale, Romney. Informative catalogue/samples that shows it all for \$2.00 (refundable). GOLDEN FLEECE, Box 40B, Manukau, Levin, New Zealand.

SILK AND WOOL . . . hand dyed with natural dyes. Large color selection in weaving, knitting, and stitchery yarns. Samples: Silk \$6.00, Wool \$4.00. DYEWORKS WJ2, 312 So. 3rd St., Minneapolis, MN 55415. (612) 333-7246.

ERRATA

Hariett Bught, author of "Fifty Years As a Coverlet Weaver", *The Weaver's Journal*, Vol. VI, No. 2, Issue 22, Fall 1981, has pointed out some mistakes we made in the draft of p. 56.

1. The last reedle of the tie-up should also be tied to shaft 4 for the 2-4 tabby.
2. In the treadling section D-E all 5 blocks should have 6 pattern picks woven on reedle-E.
3. In the drawdown all the tables should be 5 units wide. Please correct section E-E. There should have been 5 units, not 1.

STUDY OPPORTUNITIES

TWO EXPERIENCED AUSTRALIAN TEXTILE TEACHERS will be conducting five-day workshops in United States - June through August 1982 - in Colour and Design, Spinning and Scandinavian Transparency Weaving. Details from LARRY BEESTON, Box 159, Toronto, Australia 2283.

NORWEGIAN WEAVING TOUR - 5th annual. Two weeks weaving in Craftschool, sightseeing. June 1982. NORMA SMAYDA, P.O. Box 517, Saunderstown, RI 02874 (401-295-5069)

MISCELLANEOUS

VISIT NEW ZEALAND and Woolcrafts Festival May 3-22, 1982. All inclusive 3-week tour, first class hotels, most meals, private motor-coach for sightseeing, personalized attention, visits with weavers and spinners in their homes and guilds. Best travel bargain of year—\$2555.00. Write for brochure, WOOLCRAFTS HOLIDAY TOURS, Dept. 4, 15865 Asilomar Blvd., Pacific Palisades, CA 90272.

FOR SALE - MACOMBER LOOM, 56" wide, 20 harnesses. Two warp beams, one plain and one sectional. \$2500. Clotilde Barrett, 624 Peakview, Boulder, CO 80302 (303) 444-2088 or (303) 449-1170.

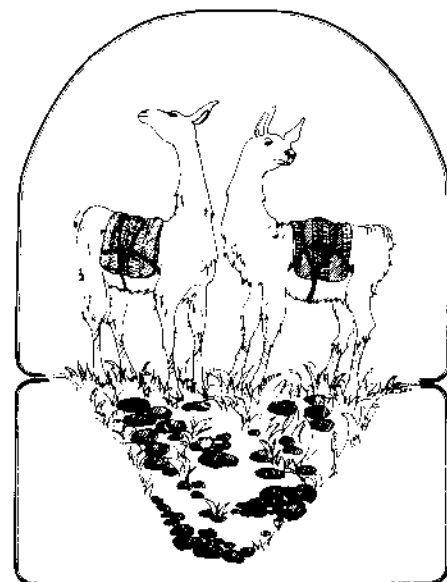

Notecards from Colorado Fiber Center. For information, write P.O. Box 2049, Boulder, CO 80306

JUST FOR YOU!

Made to your specifications, any dents per inch, lengths and widths.

Loom REEDS

QUALITY REEDS FOR OVER 50 YEARS

Write for price list:

BRADSHAW MANUFACTURING CO.
P.O. Box 425
West Columbia, S.C. 29171 USA
(803) 794-1151



PREMIUM FLEEC & MOHAIR
SPINNING & WEAVING SUPPLIES

We are agents for Clemes & Clemes spinning wheels and Brittany looms

sample book \$2.00

THE WOOL SHED

7 E. MAIN ST.
WINTERS, CA 95694

(916) 795-3262

Tat an heirloom!

Complete tatting kit includes...



3 beautiful wood shuttles!

Our exclusive birdseye maple tatting shuttles are superbly hand-crafted. 3 1/2", 4 1/2" and 6" sizes.

3 top quality threads!

#70 DMC tatting cotton, Cebelia cotton #20, and Lily Double Quick cotton—all in ecru color.



FREE BOOK!

Coats & Clark's "Learn to Tat" teaches tatting techniques plus 14 different lace patterns! It's yours FREE with kit!

Complete kit only

\$13.95 plus \$1.69 shipping and handling

Total of payment: \$15.64. Offer expires 1/31/82. Send check or money order to

Serendipity Shop
1523 Ellinwood, Dept. W
Des Plaines, IL 60016

Send 50¢ for our lace catalog.
Send \$1 for our complete fibre arts catalog.

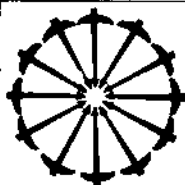

The Weaver's Journal

Support our advertisers.
They support us.

IRONSTONE YARNS

FANCY YARNS
from England

6 NEW COLORS

- Six Textures
- Seventeen Shades

Ask at your local yarn shop for our yarns

Ironstone Warehouse
P.O. Box 196, Dept. WJ1
Uxbridge, Mass. 01569



NEW from Restoration Arts — the "Normandy". Available finished in solid cherry as shown (with minor assembly), or in kit form for a real bargain. Not a reproduction wheel, but designed as a true spinning machine with the character and craftsmanship of a fine antique. Send SASE for brochure and dealer in your area. Dealer inquiries invited.

RESTORATION ARTS
132 South Pulman St. Williamston, MI 48895

Yarn Warehouse Oddlot/Continuous Supply

Categories: Hand Weaving •
Machine Knitting • Hand Knitting
• Crochet • Macrame

Now featuring our own exclusive line of imported & domestic fibers

NEW YARNS: Silk Boucle • Silk Meche
• Pure Wild Silk (12 colors) • Silk Cord
Alpaca • Victorian Cotton Lace •
French Linen/Cotton Novelties •
Chenille • Mohair/Wool Loop

ODDLOT SPECIALS: 2 ply Wool & Wool
Blends • Linen Blends • Cotton/
Metallic • Gimp • Straw & Metal

School Pack Assortments at special discounts

Send \$3.00 for samples and one quarterly mailing or \$10.00 for samples and full year of mailings.

SILK CITY

FIBERS

155 Oxford Street
Paterson, NJ 07522
201-942-1100

Most Swedish weavers select a Glimåkra® loom...

COUNTERMARCH ACTION

Mechanically creates a steady shed. Perfect for all warps, fragile to heavy. Up to 12 x 12 harness-pedal combinations. (Loom package includes counterbalance action conversion kit.)

SIMPLIFIED COUNTERMARCH TIE-UP

Braided, linked-loop loomcord and special strong nylon couplers permit rapid, KNOTLESS tie-up.

SINCE 1754 BORGES OF LUND

has maintained an outstanding reputation for quality yarns, available in a rainbow of subtle colors, myriad weights and plys.

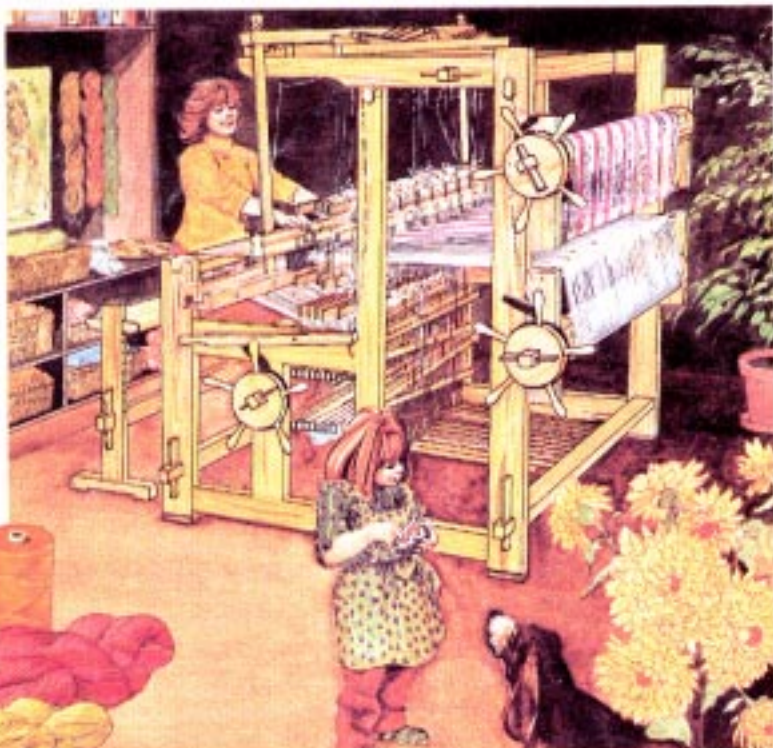

OVERHEAD BEATER

Provides well-balanced, natural beating rhythm. Height and position adjustable. Holds oversize reeds. Laminated to prevent warpage. Massive.

SUPERIOR DESIGN

Open construction facilitates tie-up and dressing. Massive, laminated beams; breast beam lifts out. String heddles and tie-up eliminate fatiguing noise. Wooden wedges, not screws, hold frame tight and make relocating easier.

OUTSIDE RATCHETS

Makes full weaving width available. Easily released by weaver. Warping sticks facilitate accurate beaming.

CONVENIENCE FEATURES

Fixed beam for weaving comfort. Adjustable bench (no extra charge). Cloth cover board keeps the work clean. Rubber feet prevent "walking."

160cm (60") counter-march looms with double-warp beam and fly-shuttle beater.

...for some very good reasons.

You've probably admired the quality of Swedish weaving. But did you know that in Sweden...and in many other countries...more weavers buy Glimåkra looms than any other brand? Why? Because Glimåkra looms are traditionally designed, with features that have evolved and been developed by skilled weavers over the centuries. That rich heritage of continuing development, enhanced by modern production methods, assures the joy of Glimåkra weaving.

Crafted almost entirely by hand, your steady, sturdy, solid Swedish loom will be a working companion and source of pride for several generations. You can weave everything from fine fabrics to heavy rugs on ALL of our floor looms. And Glimåkra

offers more than a dozen weaving widths (20" to 72"), so you can select the loom that's "just right" for your projects. (For example, you get a full 48" finished project width on our 54" loom.) We also build damask, table, and large tapestry looms (up to 80"), as well as a line of professional, heavy-duty looms, some with weaving widths of over 11 feet! Our full line of accessories includes kits for long-eye heddle, double warp beam, and fly-shuttle attachments. Looms and accessories are stocked in the U.S.

Send for a catalog and yarn samples - you'll be taking the first step toward weaving in the Swedish tradition.

Dealer inquiries invited.

GLIMÅKRA...The Silent Loom, in the Swedish Tradition.™

THE GLIMÅKRA WEAVING CENTER

Rocky River (Cleveland), Ohio

- Over 20 Glimåkra looms (including tapestry and damask models) on display for demonstration and classes.
- On-loom and off-loom classes, beginning through advanced - some for college credit.
- Specialized classes in damask, tapestry, long eye heddle and Swedish techniques.



GLIMÅKRA LOOMS 'n YARNS, INC.

P.O. Box 16157 - WJ
19285 Detroit Road (Showroom)
Rocky River, Ohio 44116 • (216) 333-7595



Please rush the Glimåkra looms color catalog (English edition) to me. My check for \$2.00 to cover postage and handling is enclosed.

Send me information regarding Borges of Lund yarns.

NOTE: Present Glimåkra loom owners -

Send me detailed information on the new, simplified, KNOTLESS tie-up kit.

Name _____

Address _____

City _____

State _____ Zip code _____

Telephone (optional) _____

Tell me more about THE GLIMÅKRA WEAVING CENTER