

The Weaver's Journal

\$4.00

Volume IX, Number 3, Issue 35

Winter 1985



In the Swedish tradition . . .
Glimåkra Looms

Borgs Yarns
. . . since 1734

From rugs to fine fabrics . . . from beginners to advanced professional weavers . . . Swedish tradition means Glimåkra Looms and Borgs Yarns.

Send \$2.50 for our full-color catalog introducing our extensive line of looms and weaving accessories. Ask your yarn store to show you the Borgs sample cards — over 1000 separate color samples of wools, cottons, linens, and cottolins (50/50) . . . or send \$10.00 for your complete set.



**GLIMÅKRA LOOMS
'n YARNS, INC.**

P.O. Box 16157-WJ7 • 19285 Detroit Road • Rocky River, OH 44116 (216) 333-7595

This picture also available as a poster. Please send \$3.95 for postage and handling.

The Weaver's Journal

Quarterly Journal for Textile Craftspeople

Volume IX, Number 3, Issue 35

Winter 1985

FEATURES

- The Use of the Dobby Loom for Multi-Harness Weave Manipulation** 9
by Elisha Renne
- A Unique Finish from an Amazonian Bracelet** 14
by Micheline Thabet
- The Wrist-to-Wrist Garment** 19
by Rose Mary Allen
- Beginning with bands: Tablet woven garments and accessories** 28
by Marilyn Emerson Holtzer
- Applying the Pulled Warp Technique to Loom-Shaped Clothing** 34
by Kerry Evans
- An Ounce of Prevention** 39
Methods for mounting
by Lotus Stack and Mary Ann Butterfield



PAGE 19



PAGE 42

- A Special Summer Vest** 42
by Lucy Anne Jennings
- Symbolic or Sacred?** 45
A personal statement
by Diana W. Lockwood
- Tied Lithuanian** 50
Notes of a Pattern Weaver
by Phillis Alvic
- Cut and Sew Mittens** 53
by Nina Winchester
- A Tailored Vest and Skirt** 56
by Ruth Arnold
- Man-made Fibers** 61
by Walter Hausner
- Doublejack or Sink the floating selvedge** 67
by William Koepp

DEPARTMENTS

- From the Editors** 4
- Letters** 5
- Complex Looms** 9
- Finishes/Shared Traditions** 14
- Fashion Trends** 24
- Meet the Authors** 79



PAGE 14

- Calendar** 81
- Study & Travel** 83
- Publications** 84
- Products** 87
- The Weaver's Market—Classifieds** 89
- Advertisers Index** 90

ON THE COVER

Knitted cuff and crocheted pocket detail on a wool coat woven by Rose Mary Allen. The article begins on page 19.

Photo by Jila Nikpay.

Photos on pages 19, 21, 36 and 57 were taken at the Nicollet Island Inn in Minneapolis. This "country inn in the middle of the big city," originally built in 1893, is on the National Register of Historic Places and has been renovated and restored with lovely Victorian decor. For information, (612) 623-7741.

◆ FROM THE EDITORS ◆

GREETINGS for the new year from the staff of *The Weaver's Journal*.

In this issue we'd like to give you a glimpse behind the scenes, and introduce you to our staff. (Meet the authors in this issue on page 79). The photo below, taken in our production area, shows the diverse group of talented and dedicated people who enjoy working together to bring you *The Weaver's Journal* each quarter. They are, left to right, beginning in the front row:

Judy Frater, circulation department assistant, is a writer, photographer and scholar focusing on the folk textiles of India. She has produced an exhibit of the traditional embroideries of Rabari nomads, and is currently working on a book and exhibit about the Rabari people and the variations in their traditional crafts and costumes. Judy has also worked as a tour director, and teaches English as a second language.

Karen Searle, co-publisher and editor was a weaving teacher and commission weaver before taking on management of *The Weaver's Journal*. She has served as editor of *The Minnesota Weaver* for the Weavers Guild of Minnesota and of the Textile Council, Minneapolis Institute of Arts Newsletter. She has co-authored two books with Sue Baizerman for their press, *Dos Tejedoras*. Karen also serves as a textile consultant to the Science Museum of Minnesota for its pre-Columbian and Mayan textile collections. She enjoys experimenting with weaving techniques and creating handwoven clothing and dolls.

Carolyn Golberg, advertising manager, combines fiber interest, administrative skills, and a love of working with people in her job with *The Weaver's Journal*. She served as coordinator of the 1984 Midwest Weavers Conference, and is currently president of The Textile Council of The Minneapolis Institute of Arts. Carolyn is also a production weaver, creating wall hangings and garments sold in boutiques in Scottsdale, Arizona and Aspen, Colorado. She and her husband have renovated a distinctive Victorian home in Minneapolis, where they live with their seven-year old daughter, Alexandra.

Back row, left to right:

Nancy Lauritsen-Smith, production assistant, is a phototype specialist. She assists in the pre-type production of *The Weaver's Journal*. Her fiber interests include spinning, knitting and weaving. She is a member of the Weavers Guild of Minnesota.

Susan Larson-Fleming, associate editor, has a background in Swedish, English and library science. She worked as a librarian and archivist before joining *The Weaver's Journal* staff. She also worked as an apprentice weaver with St. Paul designer Catherine



Ingebretsen. She has compiled and co-edited three bibliographies: *Scandinavia in English 1977 and 1978*, and *Books on Sweden in English (1983)*. She is attempting to raise her daughter Thea, bilingually.

Cynthia Bonomo Mueller, sales and circulation manager, brings to *The Weaver's Journal* her extensive experience in the retail yarn business, both as owner of her own shop in Iowa, and as manager of a large yarn shop in St. Paul. She is a weaver and knitter, and teaches classes in rigid heddle weaving. Cynthia has participated in the European Tapestry Restoration Project at the Minneapolis Institute of Arts. She is the mother of Zachary, born last fall.

Mary Liudahl, sales and circulation assistant, processes *Weaver's Journal* subscriptions and book orders, and weaves sample fabrics used in illustrating sections of *The Weaver's Journal*. She has just established her own business for the production of distinctive handwoven fabrics.

Dave Searle, programmer and handyman, has been providing *The Weaver's Journal* with computer programs to fit its business and editorial needs. He is also a railroad enthusiast. He and Karen have two teenagers.

Sue Baizerman, co-publisher and editor, is a Ph.D. candidate in the University of Minnesota's Department of Design,

Housing and Apparel, with an emphasis on ethnographic textiles. She is currently on leave from Minnesota winter with her family, to complete her dissertation research in the southwest. Sue is a weaver-knitter-author-teacher, and co-owner of *Dos Tejedoras* press. She is a research associate at the Science Museum of Minnesota and at the Museum of International Folk Art, New Mexico, and recently has collaborated with Adele Cahlander on a forthcoming book on pre-Columbian textiles.

Nancy Leeper, art director, is a publication designer, specializing in book design. She is responsible for the design and production of the magazine. She is also a dancer and singer with the Ethnic Dance Theater of St. Paul, where she has developed an appreciation of ethnic textiles through studying the company's extensive folk costume collection. Nancy edits and publishes *Ethnic Arts Quarterly*, a magazine of folk arts in the upper midwest. She is not a weaver yet, but we are working on her.

We have some exciting plans for the new year, beginning with this issue featuring handwoven clothing. Contemporary Scandinavian textiles will be featured in the spring, and ethnic textiles in the summer. We will continue to publish technical articles and project ideas, as well. Plan to be with us in 1985.

◆ LETTERS ◆

THIS IS A bit lengthy for a letter to the editor, but there seemed no way to make it shorter and still express my thoughts. . . . There has recently been quite an emphasis on "recruiting" new people to the field of handweaving and this has been of concern to me. This emphasis has come from guilds, magazines, and suppliers of materials and equipment. The article in *THE WEAVER'S JOURNAL* (Fall 1984) by Allen Fannin caused me to set some of my thoughts on paper.

Handweaving is something which requires much commitment of time, money, equipment, space, and intellect. Many people are unwilling or unable to make this commitment for anything which they deem "nonessential." This may be seen if one considers the small number of people who become real musicians, artists, or scientists.

I have watched people and talked with them; taught many to knit and some to weave and tried to teach others who insisted they wished to learn; had a shop in a tourist town and know what people will admire and/or purchase in such a situation; have given spinning and weaving demonstrations and heard all the attendant banal remarks. All this has led me to the somewhat elitist conclusion that most people just don't care—they are and will stay totally satisfied with factory-made polyester clothes, "fast foods," and non-classical music. There seems to be no way to interest these people or make them want what many of us may consider a better life.

Every so often one meets a truly special person who has whatever the inner resources are that enable one to become a weaver. These people are ready and willing to learn when the time is right. Let us devote our energy to increasing the skills and knowledge of these people and ourselves rather than wasting it on the world at large.

In the area in which I live, and very likely elsewhere, the two things which seem to be true obstacles to continued

learning and increased skill are lack of contact with other weavers and current weaving developments, and lack of a market for our products. Regional weaving conferences are a great source of inspiration and renewal to many of us. Unfortunately, these generally require the expenditure of more time, money, and travel than many weavers can manage.

The problem of marketing handwoven products seems to be a larger and more difficult problem to solve. Once one has clothed oneself and one's relatives, draped and upholstered and carpeted one's home, and given away multitudinous handwoven gifts, what is left to do with the fruit of one's labor and learning? How does one justify spending more time and money on unneeded products? How does one learn or increase one's skill without the practice of producing several articles based on a technique or variation?

Current markets for handwovens seem to demand either massive one-of-a-kind items or a continuing supply of "production" weaving. Neither of these markets is a realistic solution for most of us, as we are handweaving because we do not wish to be part of a factory but also do not have the inclination to produce one or two large "art" pieces a year.

It is to this problem that I would like to see some creative, concerned people apply some thought.

Kay Reiber
Twisp, Washington

I AM VERY PLEASED with my first copy of your publication. I have found more practical information in just one issue than I have in several of the other subscriptions I have.

Debra A. Phillips
Guthrie, Oklahoma

HAVING READ [Butterfield and Stack's] first article on textile conservation in the

latest *WEAVERS JOURNAL*, I do have a question.

I have just woven a queen-sized coverlet using cotton warp and wool weft. This was done using the double orange peel pattern. I plan to use this and know that it will require cleaning on a regular basis. Having worked a sample, I know it will shrink more than I care to have happen. I am concerned about dry cleaning also as this may damage the fibers. Have you any suggestions?

I found your article most interesting and look forward to those in the future.

Jo Clapperton
Davis, West Virginia

Mary Ann Butterfield replies:

Shrinkage in wet cleaning is a problem. A greater concern is handling a large, wet and heavy textile. Textiles should be dried flat; however needed space is not usually available in the average household.

Agitation from drycleaning is stressful to fibers and weave structures, but there are dry-cleaners who will take special care and treat the textile by hand. Since your coverlet is relatively new, it is not likely to have weak areas. Careful drycleaning should not cause much damage.

A coverlet lying on a bed collects dust just like table tops or floor. The coverlet should be vacuumed periodically to remove the sharp and abrasive dust which settles into the fiber. A piece of nylon net held in an embroidery frame will protect the threads from being pulled up by vacuum suction. Set suction on low. Regular vacuuming will reduce to a minimum the need for drycleaning.

I AM PLEASED to see that you are doing a series on textile conservation. This has been my "theme" for several years. I strongly believe as weavers we have the responsibility to choose the best suited fiber for the article we are designing. I have

LETTERS to page 8

STAFF

EDITOR/PUBLISHERS

Karen Searle
Suzanne Baizerman

ASSOCIATE EDITOR
Susan Larson-Fleming

ART DIRECTOR
Nancy Leeper

PRODUCTION ASSISTANT
Nancy Lauritsen-Smith

ADVERTISING MANAGER
Carolyn Golberg

CIRCULATION AND
SALES MANAGER
Cynthia Bonomo Mueller

CIRCULATION AND
SALES ASSISTANT
Mary Liudahl

DATA PROCESSING
David Searle

STAFF
Judy Frater

TYPESET BY
Stanton Publication
Services, Inc.

PRINTED BY
St. Croix Press

COLOR SEPARATIONS BY
R & S Litho

Copyright ©1984 Araña Press Inc. No part of this magazine may be reproduced in any form without written permission.

The Weaver's Journal (ISSN 0160-3817) USPS 384-210 is published on the first of each January, April, July and October by Araña Press Inc., 2304 University Ave., P.O. Box 14238, St. Paul, MN 55114. Telephone (612) 646-7445.

Subscription rates: \$15.00 1 year (4 issues); \$29.00 2 years; \$42.00 3 years. Outside U.S.A.: \$18.00 1 year; \$34.00 2 years; \$50.00 3 years. (US currency only please)

Second class postage paid at St. Paul, Minnesota and additional mailing offices. **Postmaster:** Send address change form 3579 to *The Weaver's Journal*, P.O. Box 14238, St. Paul, MN 55114.

The editorial committee takes no responsibility for goods advertised in this journal.

ISSN 0160-3817



**Introducing the new Harrisville Designs
Model 50 — 50" of weaving width
at a price that will amaze you.
Visit one of our fine dealers near you.**

ALASKA

Anchorage:
Hillside Woolens
907-344-4705

ARIZONA

Tempe:
Fibres & Dyes Ltd.
602-968-8861

CALIFORNIA

Claremont:
Three Bags Full
714-624-7764

Clovis:
The Yarn Shed
209-299-7101

Costa Mesa:
Denwar Craft Studio
714-548-1342

San Francisco:
San Francisco Fiber
415-821-2568

San Jose:
The Walking Wheel, Inc.
408-297-9276

Sausalito:
Wool Gathering
415-332-6433

COLORADO

Boulder:
The Weaving Shop
303-433-1133

Colorado Springs:
Just Dylightful
Handwovens
303-636-0059

Denver:
Skyloom Fibres
303-777-2331

Golden:
The Recycled Lamb
303-278-4117

CONNECTICUT

Newton:
The Sheep Meadow
203-426-4155

DELAWARE

New Castle:
Mourning Star
302-655-8269

FLORIDA

Delray Beach:
Penelope's Breads
& Threads
305-272-1000

Orlando:
Wovenware
305-425-7001

Winter Haven:
Country Feeling
813-299-YARN

GEORGIA

Athens:
Homeplace
404-549-0829

Atlanta:
Dream Weaver
404-237-4588

Rossville:
Patti's Strawberry Patch
404-861-1400

Stone Mountain:
Fiber Design Studio
404-292-5588

ILLINOIS

Chicago:
Weaving Workshop
312-929-5776

Evanston:
Shepherd's Harvest
312-491-1353

Libertyville:
The Spindle Studio Ltd.
312-367-9172

Naperville:
Bollweaver's Ltd.
312-357-3687

INDIANA

Bloomington:
Yarns Unlimited
812-334-2464

Crown Point:
Weaver's Way
1-800-348-3483

New Albany:
The Weaver's Corner
812-948-0350

New Harmony:
Harmonic Weaving Inst.
812-682-3578

IOWA

Davenport:
The Fiber Shop
319-322-3535

Des Moines:
Macra-Weave Plus
515-255-2777

Iowa City:
The Weaving Studio
319-338-1789

KANSAS

Lawrence:
The Yarn Barn
913-842-4333

Minneola:
The Wool Winders
316-885-4603

LOUISIANA

Lafayette:
Les Petits Tisserands
318-981-3888

MAINE

Bremen:
Friendship Farm
Handweaving
207-529-5771

Yarmouth:
Martha Hall
207-846-9334

MARYLAND

Baltimore:
The Weaver's Place, Inc.
301-448-2428

Chester:
Chesapeake Weavers
301-643-3477

MASSACHUSETTS

Amherst:
Webs
413-253-2580

Arlington:
Batik & Weaving Supplier
617-646-4453

Harvard:
Fiber Loft/Bare Hill
Studios
617-456-8669

Rochester:
Wildflower Fiber Studio
617-763-8716

MICHIGAN

Frankenmuth:
Rapunzel's Weaving &
Arts
517-652-8281

Muskegan:
The Weaver Bird
616-728-6424

Northville:
Traditional Handcrafts
313-349-7509

MINNESOTA

Mound:
Spring Creek Farm
612-472-4524

MONTANA

Bigfork:
Rainbow's End
Needlework Studio
406-837-6967

Missoula:
Joseph's Coat
406-549-1419

NEW HAMPSHIRE

Hampstead:
Tulip Tree Farm
603-329-5080

Union:
Andes Quality Yarns
603-473-2555

NEW JERSEY

Cape May:
The Golden Fleece Yarn
Shop & Weaving Studio
609-884-1718

Clinton:
Fibre Crafts
201-735-4469

NEW MEXICO

Albuquerque:
Village Woools
505-883-2919

Santa Fe:
Santa Fe Weaver's School
505-983-8058

NEW YORK

Akron:
Daft Dames Handcrafts
716-542-4235

Binghamton:
The Weaver's Place
607-722-2274

Henrietta/Rochester:
The Fiber Shop
716-334-4281

Ithaca:
The Tabby Shop
607-273-3308

Manlius:
NBR Weavers
315-682-6601

New York:
Dariff Design Assoc., Inc.
212-243-8091

North Rose:
Focus on Fiber & Design
315-483-9300

Poughkeepsie:
Magic Heddle
914-471-7334

Syracuse:
Fayette Works
315-478-6832

NORTH CAROLINA

Asheville:
The Weaver's Web
704-252-3221

Dillsboro:
Riverwood Handweaving
704-586-9418

NORTH DAKOTA

Fargo:
Silks & Yarns
701-280-1478

OHIO

Carroll:
A Touch of Americana
614-756-4458

Oberlin:
The Loom Shed
216-774-3500

Streetsboro:
The General Store
216-653-8998

Waverly:
Southern Ohio Crafts
614-947-5465

OKLAHOMA

Oklahoma City:
Hares-N-Wares
405-324-6619

Tulsa:
Johnson Atelier Weaving
Co-op
918-438-0272

OREGON

Bandon:
Westerly Webs
503-347-3682

Portland:
Handspun in Oregon
503-246-3436

Portland:
The Knotting Chamber
503-232-1043

Salem:
Millstream Yarns
503-364-4019

PENNSYLVANIA

Butler:
Knothings by Mary Ann
412-586-5325

East Berlin:
The Mannings
717-624-2223

Easton:
Handcrafter's Studio
215-253-7031

Lancaster:
Dapple Crafts
717-872-2756

Millheim:
Jean Giddings, Weaver
814-349-5536

Pittsburgh:
The New Spinning Wheel
412-364-1021

Pittsburgh:
The Yarn Connection
412-681-3830

Wayne:
The Artisan's Accomplice
215-688-6658

TENNESSEE

Maryville:
Kay Hultquist Weavings
615-983-3277

Oak Ridge:
Such a Simple Art
615-482-2173

TEXAS

Austin:
Hill Country Weavers
512-474-6773

Lubbock:
Beck's Warp & Weave
806-799-0151

Corpus Christi:
Padre Island Weavers
512-881-9329

Dallas:
Spindletop Yarn Shop
214-691-2489

Houston:
Craft Industries
713-789-8170

Humble:
Golden Threads
713-446-8766

VERMONT

Hardwick:
Yarn & ... Crafts
802-472-6166

St. Johnsbury:
N. VT. School of Fiber
Arts
802-748-4821

VIRGINIA

Chester:
Weaving Lady Studio
804-748-9036

Christiansburg:
The Golden Ram
703-382-6270

Newport News:
The J & L Studio
804-877-8859

Virginia Beach:
Handweaver
804-497-1461

WASHINGTON

Coupeville:
Coupeville Spinning &
Weaving
206-678-4447

Gig Harbor:
Wools Unlimited
206-851-5233

Grandview:
The Lazy Squaw
509-882-2302

Lacey:
Loom Room
206-491-6554

Olympia:
Looms & Lessons
206-352-5906
206-943-1118

Seattle:
Weaving Works
206-524-1221

Spokane:
Purple Pocket
509-838-8716

WEST VIRGINIA

Shenandoah Jct.:
Jessica Freeman Woods
304-876-6063

Wheeling:
Sara's Rosepath Gallery
304-232-8628

WISCONSIN

Fort Atkinson:
The Barb Patch - Weaving
414-563-7228

Madison:
Weaving Workshop
608-255-1066

Milwaukee:
The Wool Works
414-278-8838

Sister Bay:
Scandinavian Village &
Wool Gathering
414-854-4325

Star Lake:
Cabin Fever Weaving
Studio
715-542-3871

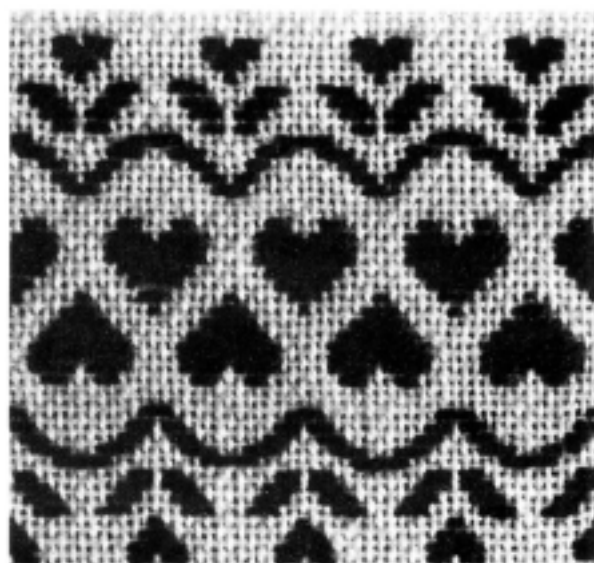

Complete Sample: \$4.00

HARRISVILLE DESIGNS
Harrisville, New Hampshire

The Use of the Dobby Loom for Multi-Harness Weave Manipulation

by Elisha Renne

Figure 1. Detail of the chain lag on the Harris doobby loom owned by the University of Minnesota, St. Paul.

MULTIPLE-SHAFT looms offer the weaver infinite pattern design opportunities. One obstacle to investigating these opportunities is the cumbersomeness of changing twenty shaft threadings or tie-ups. Marilyn van der Hoogt's article, "Turned Drafts in Double Two-Tie Unit Weave", in the fall, 1984 issue of *The Weaver's Journal* suggests the two-tie system for generating different weave structures from the same threading and tie-up. The following article uses a similar approach though not in the two-tie system. The same pattern threading is used but with different tie-ups, to produce different weave structures from the same warp. The use of different tie-ups is particularly suitable to the doobby loom.

Anyone who has composed weaving drafts using block design is familiar with substituting different weave structures in essentially the same block design. A typical block motif, the "snowball," may be woven in double weave, summer and winter weave, Bronson lace, or crackle weave. Similarly, many of the weave structures that are based on twills may have identical or similar threadings, rather than pattern blocks. Depending on the tie-up, different, though related weave structures result.

The doobby loom is particularly well suited for this type of weave manipulation as the tie-up (better described as "pegging") is easily altered by changing the sequence of the pegs on the chain lag (Figure 1.) Since the



Figure 2.
Combination
threading draft
combining twill
diaper, point twill
and point twill
variations. Figures 3,
4 and 5 illustrate the
different results when
different tie-ups are
used. The treadling,
woven as drawn in
remains the same.

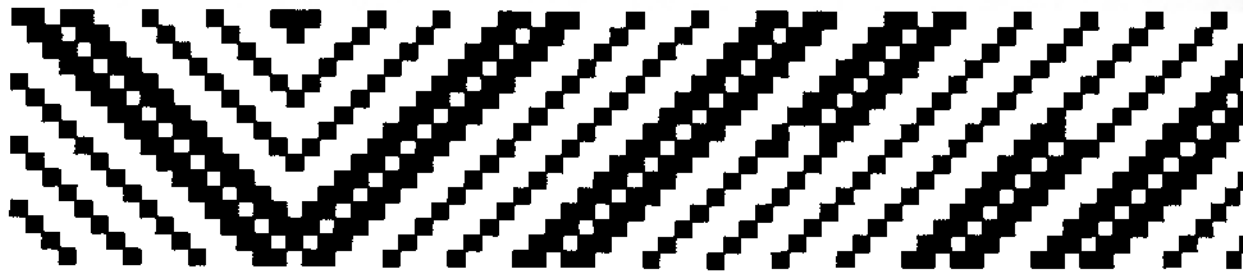
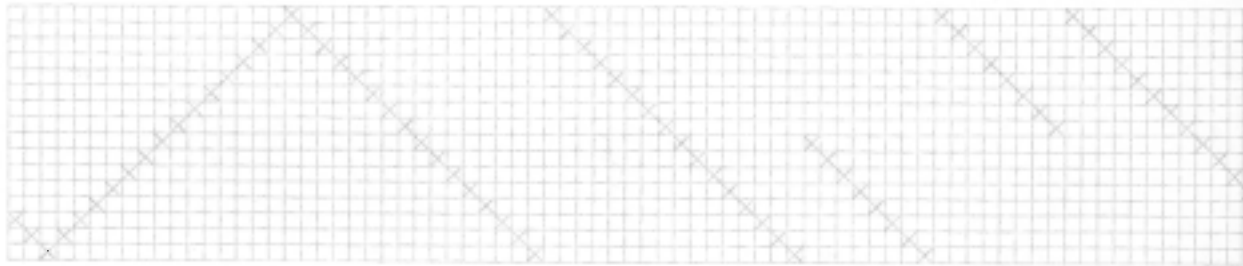
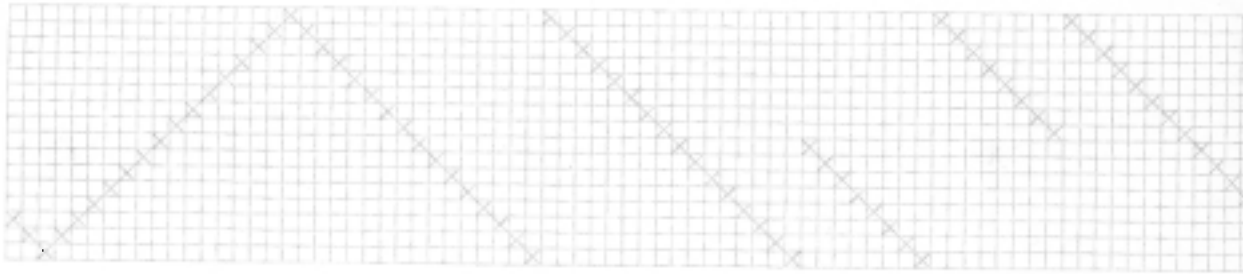

Figure 3. Simple
point twill tie-up and
resulting draw-down.

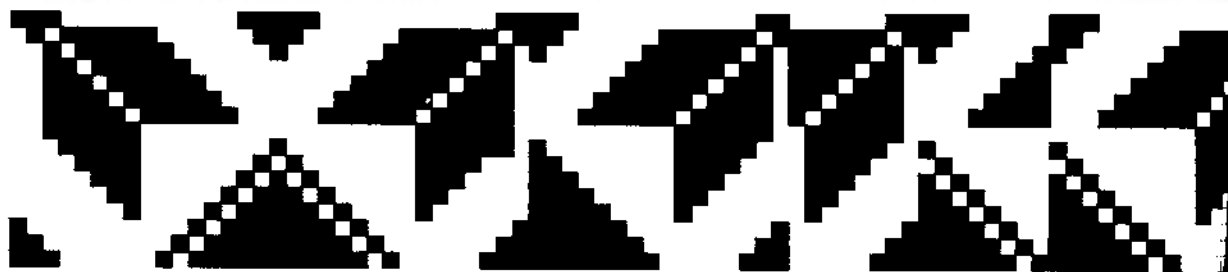
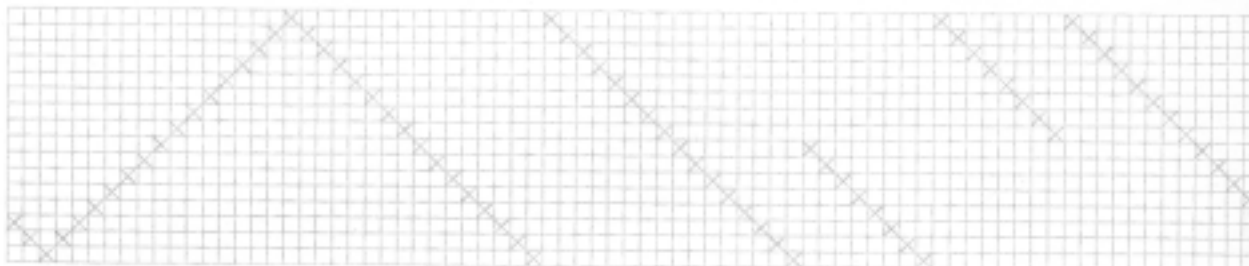
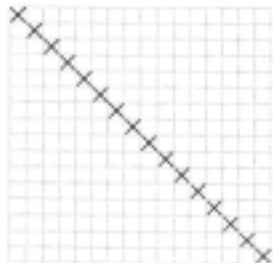
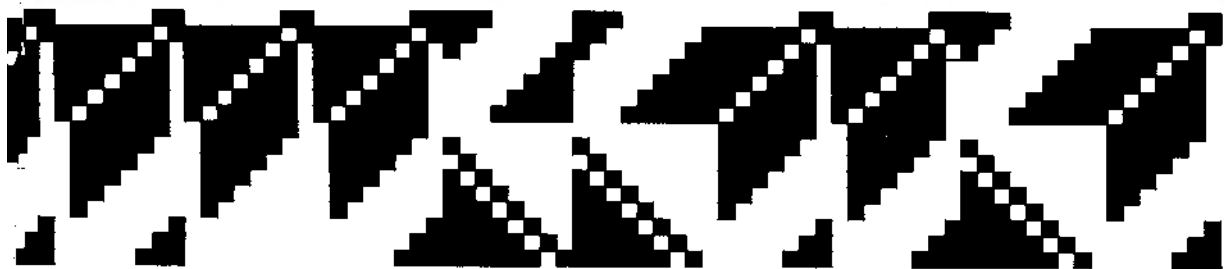
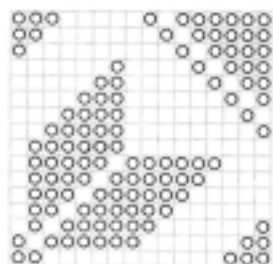
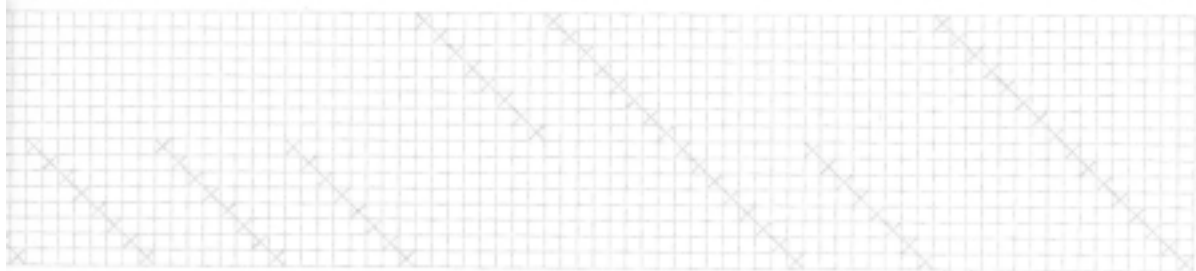
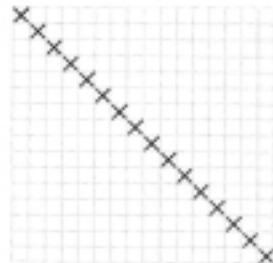
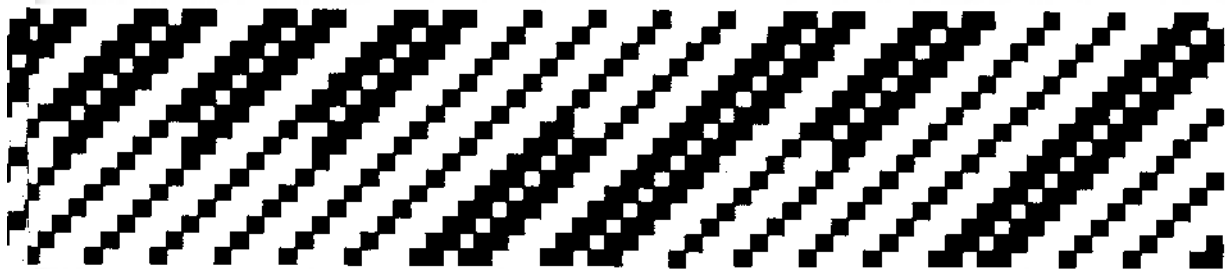
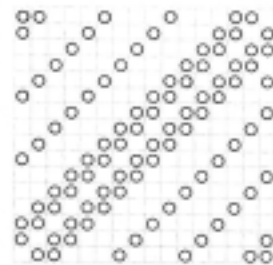
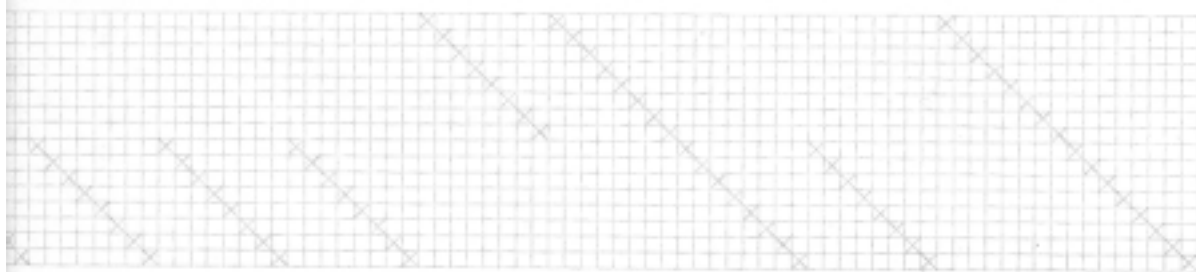
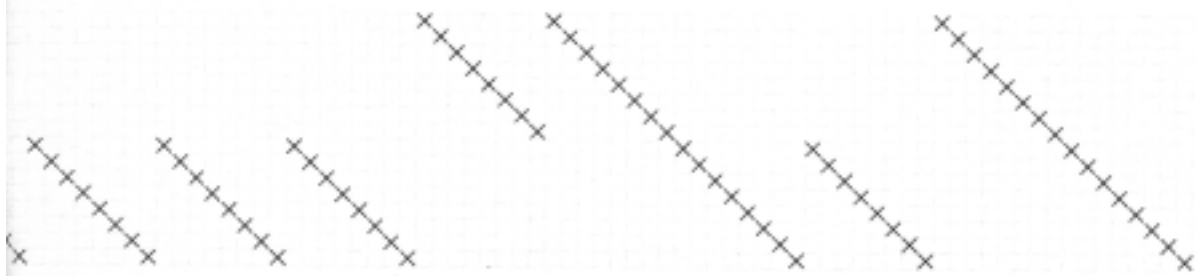

Figure 4. Star pattern
tie-up and resulting
draw-down.



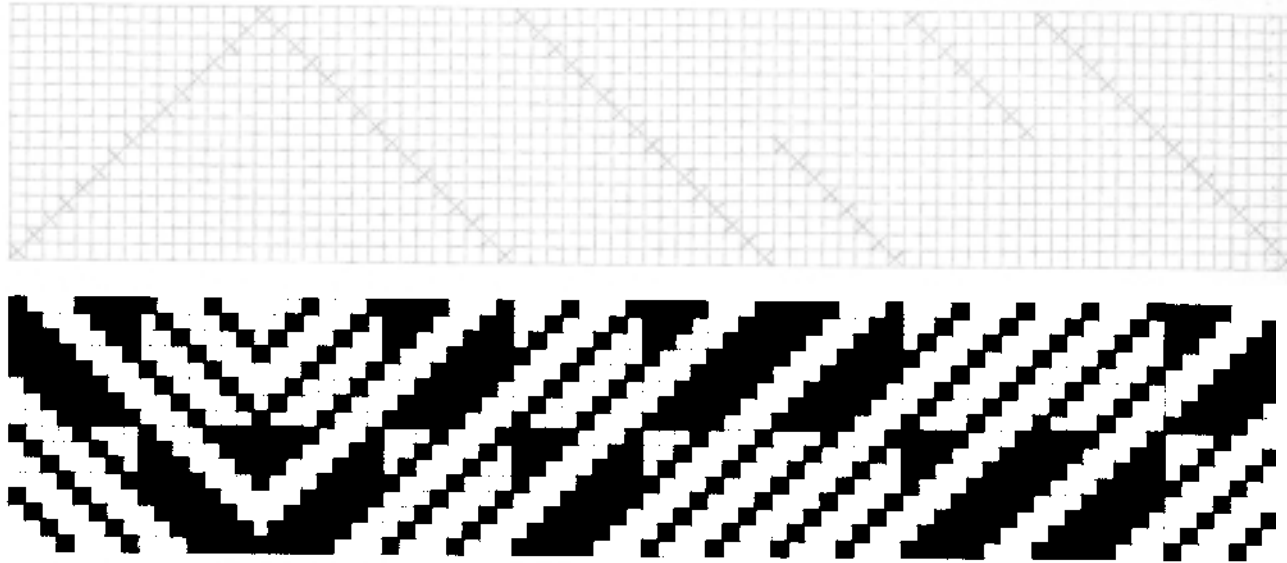

Figure 5. Twill diaper variation tie-up and resulting draw-down.



Figure 6. Photo of fabric woven with the tie-up in figure 5. cotton and wool, by E. Renne.

weaves involved are multiple-harness weaves, the dobby loom is more flexible than the regular 16-harness floor loom. The chain lag mechanism and resulting single treadle eliminates the need for complicated multiple-pedal treadlings.

The effects of this pegging variation may be seen using a threading draft that incorporates elements of the twill diaper, point-twill, and point twill variation threading drafts (Figure 2) A simple 16-harness point twill tie-up,

treadled "as drawn in," is shown in Figure 3. The eight-thread repeats in the threading draft of Figure 2 result in darker block-like sections as compared to a regular point twill threading, which consists of 16 harness reversing twill sequences.

Any of the more complicated stars, hearts, or flower drafts may be substituted by re-pegging the chain lag. While the effect, using the threading draft in Figure 2, is somewhat discontinuous as compared to normal twill threadings, it is not uninteresting. (Figure 4.)

A somewhat combined effect may be woven by using a tie-up that incorporates elements of the point twill and twill diaper ties. (fig. 5) At first glance, this tie-up appears to be a simple point twill; on the other hand, when divided into quadrants, blocks of contrasting light and dark appear. The resulting woven piece combines the point twill ornateness with contrasting twill blocks. (Figures 6, 7, 8.)

By changing the tie-up to an entirely different weave structure, twill diaper, a completely different looking fabric results. A profile draft of Figure 2 can be interpreted in two ways, depending on whether one uses a normal twill diaper tie-up with 4 harnesses per block or an adapted tie-up with 8 harnesses per block. (Figures 9 and 10.) As can be

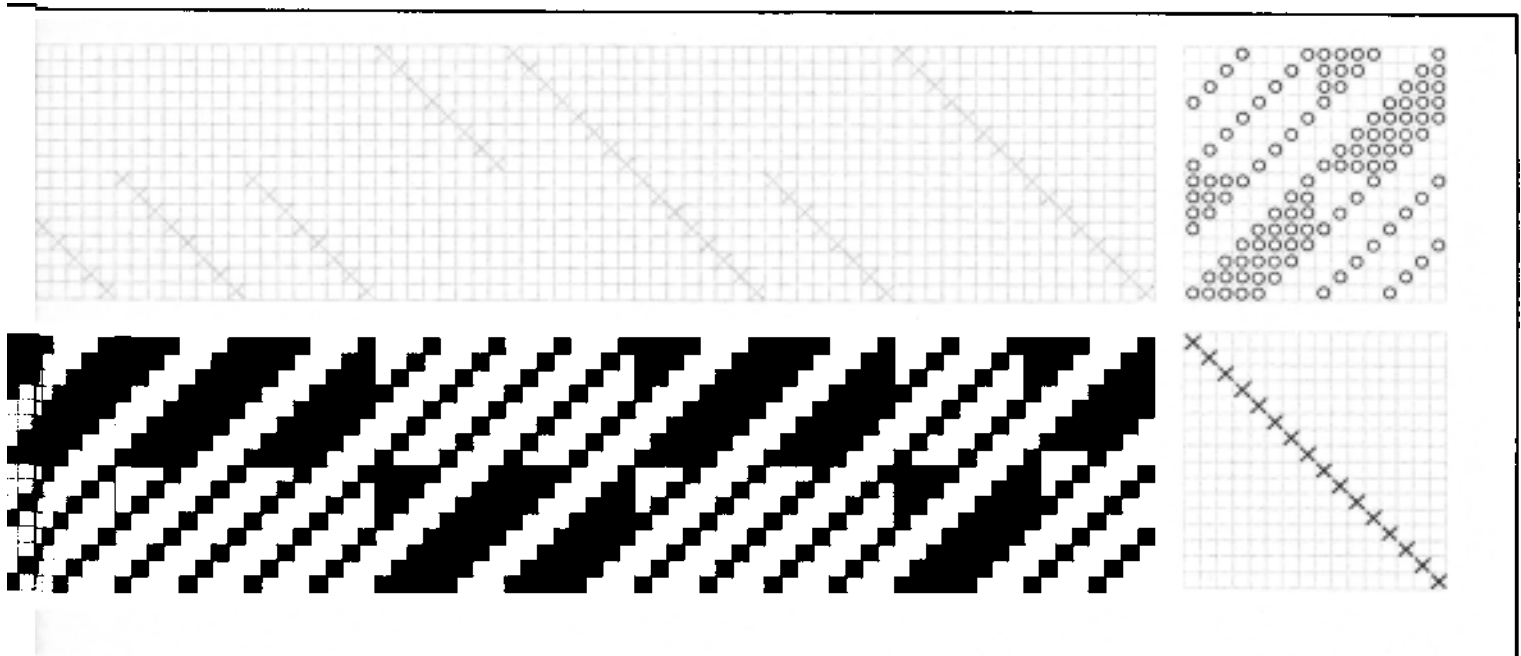
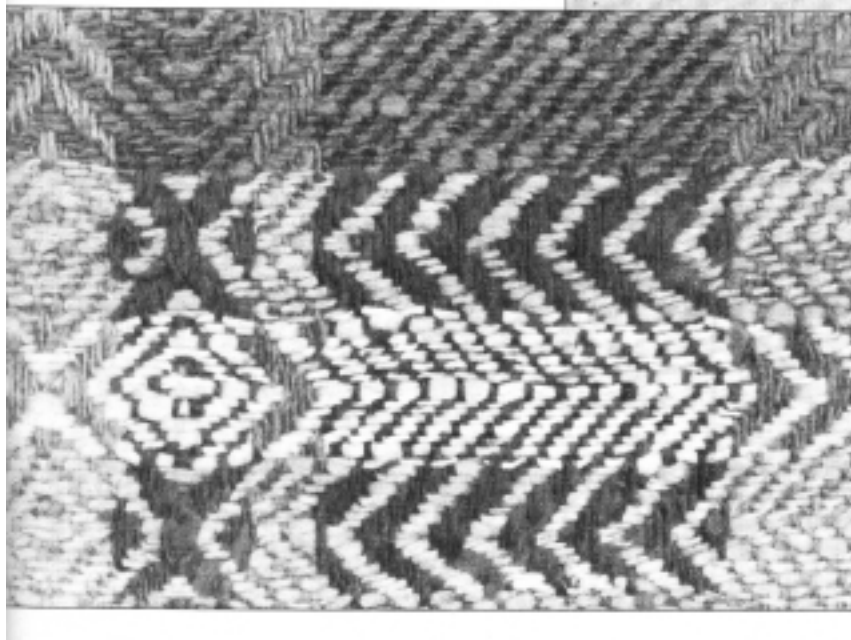
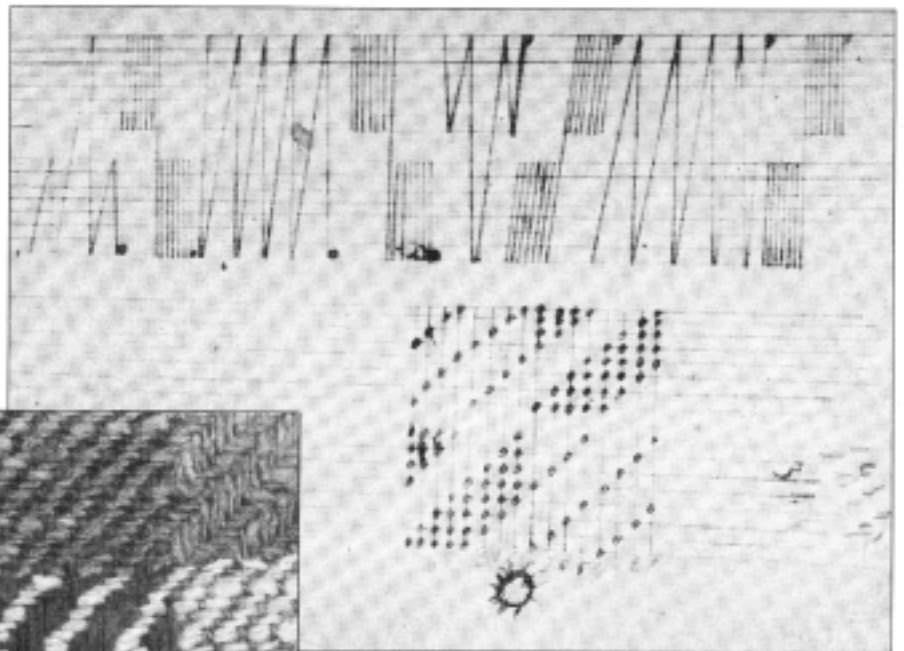

Figure 7. Photo of draft with twill diaper variation tie-up, 16-harness, from the Allen-Stephenson Draft Book, courtesy of the Art Institute of Chicago.

Figure 8. Photo of textile woven from the draft in figure 7, cotton-rayon, by E. Rennie.



seen from the drawdowns, the design effect is more block-like, compared to the more ornate effects of the point twill tie-ups.

By adding a foundation tabby to the weft, along with a heavier (usually wool) pattern thread, a supplementary weft weave results. There is an example of this type of weave in the *Allen-Stephenson Draft Book*, originally owned by the nineteenth century handweav-

DOBBY to page 77



A Unique Finish from an Amazonian Bracelet

by Micheline Thabet

◆ FINISHES/SHARED TRADITIONS ◆

WHILE ATTENDING A workshop on Peruvian textiles at Convergence '82, I had the privilege of meeting a "Curious Mind," Anne Blinks¹, who taught me how to weave and finish an unusual piece of weaving.

The technique was developed by the Mayoruna Indians of the upper Amazon Basin, in Peru, who have a very original and practical way of finishing their bracelet.

The weave is started with warp loops wound on a fine stick (I use a fine metal knitting needle) (figure 1). When the desired length of the weave is obtained, twist the ends in groups of four or six strands (figure 2). Replace the stick by a cord (four or six-ply strand, the same color as the band) using a needle or a hook. Make an overhand knot (double knot if necessary at both ends of the cord to secure it (figure 3). With a crochet hook, pull the twists of fringe through the holes between the heading cord and the first weft, spreading them evenly. Adjust the length of the twisted ends over the hand so the bracelet will be easy to put on. Make an overhand knot on each twist and trim the surplus (figure 4).

This ingenious finishing method is adaptable to any kind of hand-manipulated weaves or braids.

Bibliography

Blinks, Anne, "Notes on Plaiting in the Upper Amazon Basin, Peru." *Interweave*, Vol. V, No. 4, 1980. P. 51-52.

¹*In Celebration of the Curious Mind . . . A Festschrift to honor Anne Blinks on her 80th Birthday*, Nora Rogers and Martha Stanley, Editors. Interweave Press, 1983.

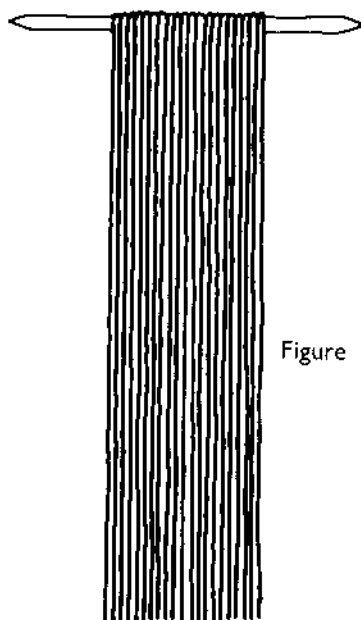
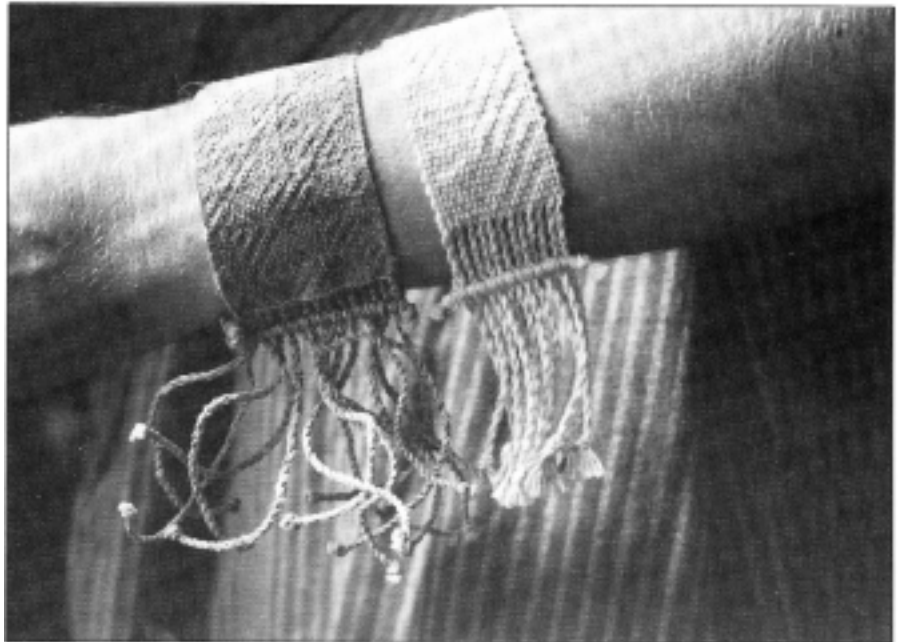

Figure 1.

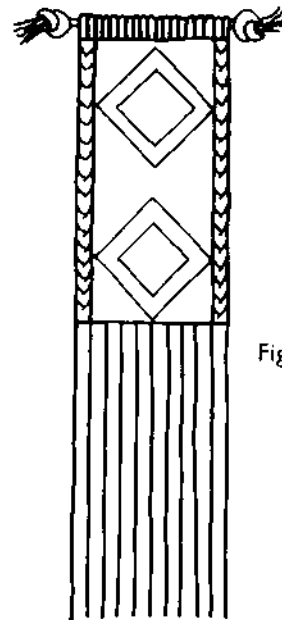

Figure 3.

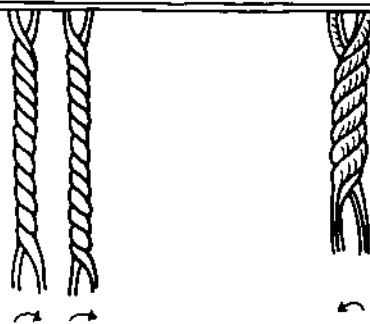

Figure 2.

Ply fringe by first twisting two groups of warp ends tightly. Put the two groups together and twist in the opposite direction. Tie the ends in an overhand knot.

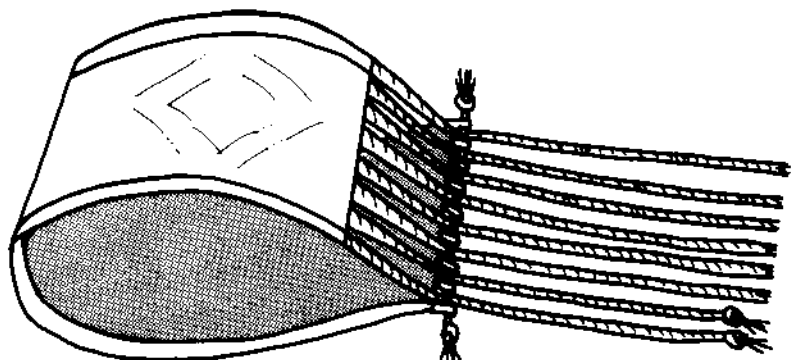
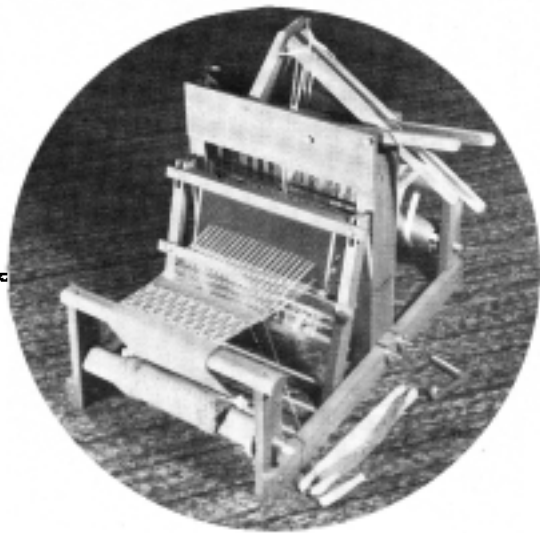

Figure 4.



the serious weaver's Delight

The Sampler is for the weaver who does not want to waste time, effort or warp when creating new patterns or trying new ideas. This simple, easy-working, 'take-along' loom lets you get your answers in a hurry. And with the exclusive Multi-Dent and Mini-Dent reeds you weave up to 4 different setts in just one weaving. No other loom just like the Sampler. Better get to know more about it, hundreds in use. Find out also about the Sievers School of Fiber Arts at the same time.

Sievers

Write today
Walnut Street, Washington Isle, WI 54246

FREE TO GUILDS!

One year subscription (or renewal) of *The Weaver's Journal* FREE to your guild in exchange for nine subscription years (new or renewal) from your members. Send full payment in one envelope to *The Weaver's Journal*, P.O. Box 14238, St. Paul, Minnesota, 55114.

EXPAND YOUR GUILD LIBRARY

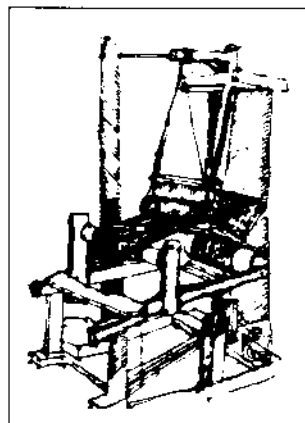

Stationery Special

Weaver's Journal
Note Cards

\$2.00/pkg. of 10 cards with matching envelopes

Choose from 9 different designs—see page 75 for selection

The Weaver's Journal
P.O. Box 14238
St. Paul, MN 55114



COTTON

Perle Cotton (3/2, 5/2, 10/2)
Fine Cotton (20/2, 30/2)
Lofty Cotton (4/4)
Warp Cotton (8/2, 8/4, 8/6, 8/8)

dyed to match our 30 linen colors
(except 20/2, 8/6, 8/8)

Yarn Identification Card \$1.60
Yarn Color Card \$1.60

Free Catalogue

FREDERICK J. FAWCETT, INC.
320 Derby Street, Salem, Mass. 01970
Dept. W (617) 741-1306

EXCITING

DYES

cotton · wool · silk

Space dye or solid shades
on ALL natural fibers

BATIK · PAINT · STENCIL

All at room temperature
NO boiling == NO steaming
PERMANENT WASHFAST COLORS

FREE CATALOG & INFORMATION

Specialists in Fiber Coloration

PRO Chemical & Dye Inc. 

Dept WJ PO Box 14
Somerset, Ma. 02726
617-676-3838

IRONSTONE YARNS

FANCY YARNS
from England

6 NEW COLORS

- Six Textures
- Seventeen Shades

Ask at your local yarn shop for our yarns

Ironstone Warehouse
P.O. Box 196, Dept. WJ1
Uxbridge, Mass. 01569



treenway crafts ltd.

BEWEAVE IT OR NOT!!!

Our yarn, fibre, book and equipment selection is so fine; weavers, knitters and spinners from around the world deal with us. You should too!!!

MAIL ORDER ONLY.
DEALER INQUIRIES
WELCOME. ORDER YOUR
CATALOGUE TODAY:
\$2.75

Treenway Crafts Ltd. 3841
Duke Road, RR 1, Victoria,
British Columbia, Canada
V8X 3W9
Telephone: (604) 478-3538

NEWS

New England Weavers' Seminar

New England Weavers' Seminar

July 22 through July 25, 1985
University of Massachusetts
Amherst, Mass.

General Lecturers:

Persis Crayson, Nancy Harvey,
Doramay Keasbey, Dini Moes

30 Special Interest Seminars Room Shows
Swaps Sessions Special Exhibits
Demonstrations Juried Members Exhibit
Fashion Show Expanded Commercial Exhibits

DAILY and FULL REGISTRATIONS
ACCEPTED

Subjects for all levels of weaving ability.

BEFORE NEWS WORKSHOPS

July 20 and 21, 1985
Persis Crayson, Doramay Keasbey,
Antonia Kormos, Dini Moes,
Patricia Spark, Naomi Whiting Towner

For complete program brochure and
registration form, write after Feb. 1:
Anne Carlson, Box 212
West Falmouth, Massachusetts 02574

Interested Commercial Exhibitors please
contact: Ms. Adele Harvey, Boyce Farm
Rd., Lincoln, Massachusetts 01773

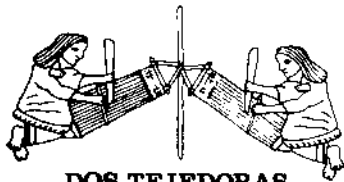

DOS TEJEDORAS

Now Available
Hammock Making Techniques by Penelope Drooker.
Covers a variety of fiber techniques \$8.00 paper

Latvian Mittens by L. Uptis, with color photos and over
100 graphs \$10.50 paper

Cornish Guernseys and Knie-Frocks by M. Wright, with
photos, charts and instructions \$8.00 paper

Patterns and Textures for the Rigid Heddle Loom by
B. Davenport \$5.95 paper

Finishes in the Ethnic Tradition Baizerman & Searle.
\$7.50 paper

Latin American Brocades Baizerman & Searle. \$5.00
paper

Postage and handling: \$1.00 for first book, .50 for
each additional book.

Send to: DOS TEJEDORAS, 3036 North Snelling
Ave., St. Paul, MN 55113 (612) 646-7445.

GRANDOR YARNS

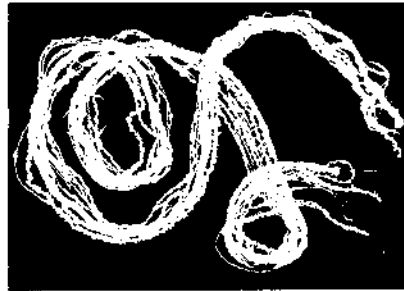

"For the unusual yarns in—

- Wool BERBERS in various weights.
- Textured cottons, linens, mohairs.
- Warps in linen, cotton & cotton/linen.
- Silks & silk/wool blends.
- "SUNBEAM" colors and mixtures.
- McMorran Yarn Balance

Complete set of samples \$3.25, wholesale only

GRANDOR INDUSTRIES, LTD.

Dept. WJ, P.O. Box 5831, 4031 Knobhill Dr.
Sherman Oaks, CA 91403 - (818) 784-5855

NEW The  **Care & Feeding
of Baskets**
BY EMILY HARTLEY \$8.95

the Mad Weave
\$6.95 book 
BY SHEREEN LAPLANTZ
A COMPLETE HOW-TO BOOK

POSTAGE & HANDLING:
\$3.00 FOR FIRST BOOK,
.50 FOR EACH ADDITIONAL BOOK
CAL. RESIDENTS ADD 6% SALES TAX

PAYABLE IN US FUNDS ONLY

The News Basket
A BASKETRY PERIODICAL
3 TIMES A YEAR

US/CANADA	FOREIGN
\$6.00/1yr	\$9.00/1yr
\$10.00/2yr	\$16.00/2yr

EXOTIC BASKETRY MATERIALS

CATALOG \$1.00

NEW PRESS DE LAPLANTZ
88 BAYSIDE CUT-OFF
BAYSIDE, CA 95524

ADVERTISE WITH US!

Contact Carolyn Golberg at *The Weaver's Journal*,
P.O. Box 14238, St. Paul, MN 55114. (612) 646-7462



IF YOU WEAVE . . .

The Mannings have everything you need!!!

Instruction * Resident instruction in all types of weaving. Special classes for beginners.

Looms * Leclerc - Gallinger

Rug Yarns * Over 300 colors 2-3-4-6 ply. Special skein wool for vegetable dyeing.

Fine and Fancy Yarns: cottons - linens - mohairs - wools - novelties - chenilles

Name Brand Yarns By: CUM, Lily, Fawcett, Reynolds, Plymouth, Stanley Berroco, Harrisville, Kolmes

**ORDER TOLL FREE
DIAL**

1-800-233-7166

In Pennsylvania Call

1-717-624-2223 and receive 1.00 phone allowance on orders over 15.00

Catalog and Rug Wool Samples - .50

**THE MANNINGS
R. D. 2
East Berlin, PA 17316**



A NEW JOURNAL FOR CREATIVE TEXTILES

In the Federal Republic of Germany an association with a journal is being founded as a forum for all those who are interested in creative textiles. Its members belong to the various fields of textile activities, as there are textile art, design, craft, adult education, teaching in schools, trade with textile art and materials. The development in some of these spheres has grown rather quickly during the last years; the necessity for more information—also from over the German borders—became more and more apparent.

Our main point will be the supply of information and the promotion of contacts and interchanges among persons interested in textile art. Further we wish to reflect on tendencies and enforce trend discussions regarding the development. At last, presentations and positions of individuals from the textile scene are planned. The DEUTSCHES TEXTILFORUM should be a working medium and a "roundabout" for references and contacts!

Textilforum

Postfach 5944 3000 Hannover West-Germany

Warp-Aide

THE
WARP WINDING WONDER

CUSTOM MADE
BY

WRITE

4961 CEDAR RAVINE
PLACERVILLE, CA 95667

WILDE YARNS FOR HANDWEAVING

All Wool Yarns
for Handweaving

Carded Wools for
Handspinning and Felting

Natural and Dyed Colors

**Send \$4.00 for Sample Cards
Dealer Inquiries Invited**

WILDE YARNS®

**3705 Main St. Dept. W
Philadelphia, PA 19127**

A Tradition in Spinning Since 1880

**DAFT
JAMES
HANDCRAFTS
YARNS**

NATURAL & SYNTHETIC

Sample Sets \$1.50 Each

1. 5/2 PEARLE COTTON
2. 10/2 POLYESTER
3. SILK
4. SHETLAND WOOL/POLYESTER
5. RAYON CHENILLE
6. 16/2 MERCERIZED COTTON
7. COTTON FLAKE

P.O. BOX 148C AKRON, N.Y. 14001

Quilt Lovers

Something new to write your own original quilt style. Ten original designs by Jane Rivers and Nancy Grable. Available in paperback for \$4.95.

Six designs by The Myers. Available in paperback for \$3.95. Available in paperback for \$3.95.

Please include 75¢ for post and handling. MN residents add 10% sales tax.

UnderCovers™

5736 1st Avenue South
Minneapolis, Minnesota 55412

Write for information and order.



The Wrist-to-Wrist Garment

by Rose Mary Allen

IF YOU'RE ANYTHING LIKE me you really enjoy wearing elegant handwoven garments. In fact you'd like an entire wardrobe of handwoven clothing. But, all that complicated loom shaping—the wide fabric widths and having to cut your fabric—can bring the most determined weaver to a halt.

And so it was that I began weaving wrist-to-wrist garments.

Wrist-to-wrist garments are made from narrow fabric widths. They don't require numerous pattern pieces or yards and yards of fabric. This garment design allows me to weave fabric on narrow looms and with minimal seaming, I have an attractive garment

that offers versatility of style. Not only that, but the traumatic experience of cutting my handwoven fabric is greatly reduced, allowing me to enjoy my project more.

The wrist-to-wrist basic shape

The garment is created by two lengths of fabric. The main piece forms the sleeves and yoke. Another length of fabric becomes the garment body.

The white-and-purple sweater and the natural cotton short-sleeved blouse shown in the photos have the warp running horizontally through the body of the garment with no

Winter coat (also pictured on the cover). The fabric is woven using a random warp composed of Simpkins 2-ply wool, brushed wool and loop wool from Stanley Berocco, and Indiecita alpaca. The weft is handspun New Zealand wool. The fabric was fulled in the washing machine and shrank about 20%. The sleeves are pleated into knitted cuffs with a matching knitted collar at the neck. A crocheted edging forms the buttonhole bands. The entire coat is lined with the addition of a Thinsulite® interlining.

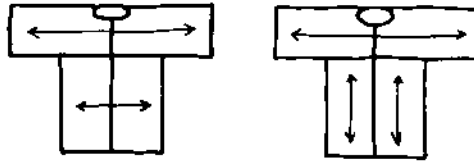
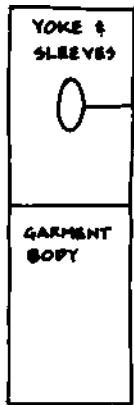

seams in the body area. The long grey coat and long-sleeved cotton jacket are garments with vertical warp in the body area which is seamed at the sides.

The warp direction will be determined by the design of the cloth, how you want the garment to hang and the number of seams desired.

Determining the length and width of your fabric pieces

The width of the yardage for yoke and sleeves is determined by the length required to circle your shoulder at the underarm (generally about 20 inches).

The length of the panel for yoke and sleeves is determined by measuring from the desired sleeve length on one arm, up that arm and across the shoulder to the same point on the other arm. With a long sleeved jacket, measure from wrist bone to wrist bone. Measurement is best done across the back of the body with the elbows slightly bent.

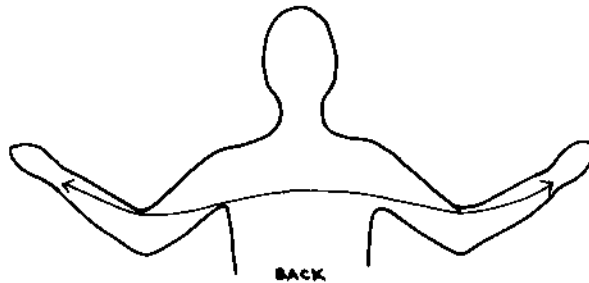
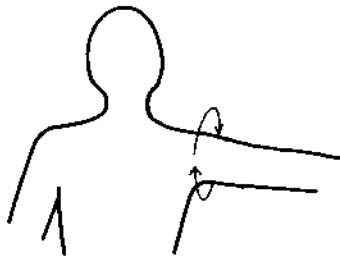

The length of the panel for the body can be determined several ways. For a garment with a horizontal warp throughout, measure the bust and hips. The length must be at minimum several inches larger than the bigger measurement. Add more length to give further ease or to allow for gathers and pleats.

If you choose to use a vertical warp for the body section, there can be 2 or more panels. Measure from the underarm to the desired length and multiply this by the number of panels you intend to use. In the long sleeved cotton jacket, two panels are used. The long grey coat employs three panels to create a fuller garment.

It is a good idea to make a muslin test pattern for your first wrist-to-wrist garment. The critical points to fit are the areas where the

yoke and body are attached and the neck opening.

With muslin, you can experiment to achieve the best fit. You also will have a good pattern to use when cutting the neck opening in your handwoven fabric. In addition, the pattern can be used for future wrist-to-wrist clothing.

A word about fit . . .

As I stated before, the most critical points of fit are in the yoke. The circumference seam at the underarm level is the most important one in determining how your garment hangs.

There is a great deal of leeway in the ease required at this seam. You can start by measuring around your body just above the bust.

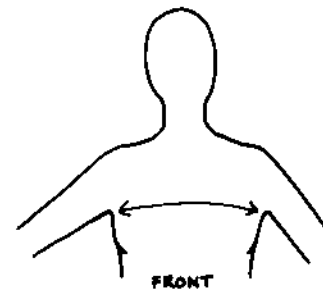

This measurement will be the minimum amount required for the seam which joins the yoke to the body. I suggest that you add several inches of ease in this area. But the best way to guarantee a good fit is through experimentation with your muslin garment. It is critical that this yoke-to-body seam be large enough to allow ease of movement. However, it should not be too large because the way the garment hangs is entirely dependent on this seam. If the seam is too generous, the yoke will not sit evenly on your shoulders, the garment sides will be longer than the front and back, and the fabric will not hang true to grain.

The yoke construction process that I use also requires that a neckline be cut into the fabric. This is the only cutting required for the wrist-to-wrist garment, but the experience is no less traumatic.

Here again, the muslin garment is a big help in determining where the neck opening should be placed. The neckline should be higher in back than in front. When deciding on a neck opening, mark the center of the muslin yoke pattern in both the vertical and horizontal directions. Mark the front and back, and mark the back neck, side neck and front neck.

To create a basic round neckline, I sug-



gest measuring 1 inch from the shoulder line for the back, 3–5 inches from the shoulder line for the front and 2½ to 3 inches from the center on each side for the neck width. These dimensions will give you a close fitting neck opening. For a larger opening, increase the dimensions.

Connect these marks with a curved line and you can cut the neckline and try it on for fit. At the same time you can cut up the center front of the yoke piece to create the front opening for the jacket.

Once you have established an appropriate neckline shape on the muslin, the pattern can be transferred to the handwoven fabric with marking pencil or by basting.

Before cutting into your fabric, it is advisable to stitch along the front and neck marking lines once (or even twice for extra security) before cutting. This will also give you a firm edge to finish over.

Finishing

Now, let us assume that the fabric has been woven and subjected to some sort of finishing process.

I generally weave the yardage in one piece and cut it apart after it comes off the loom and has been fulled. It is most important that the yoke and sleeve section match the dimensions of your muslin pattern. The

Cotton jacket. The fabric is woven from a warp composed of a variety of fine cottons. The weft is a fine silk with a shot of novelty cotton every 4th pick. A crocheted edging forms the front buttonhole closing. Knitting forms the cuffs and a ribbed waistband.

White and purple sweater. Woven from a warp of Ft. Crailo 2-ply wool and mohair from Harry's Attic, with a weft of fine loop wool. A knitted ribbing forms the cuffs and finishes the front and neck edges.

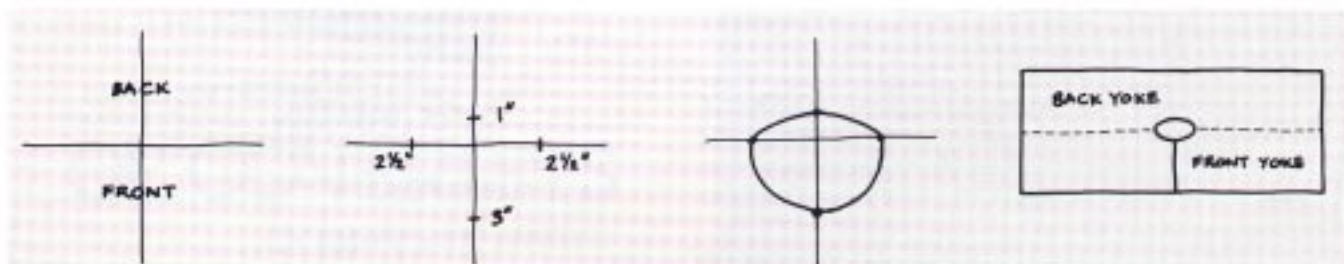

Neck opening.

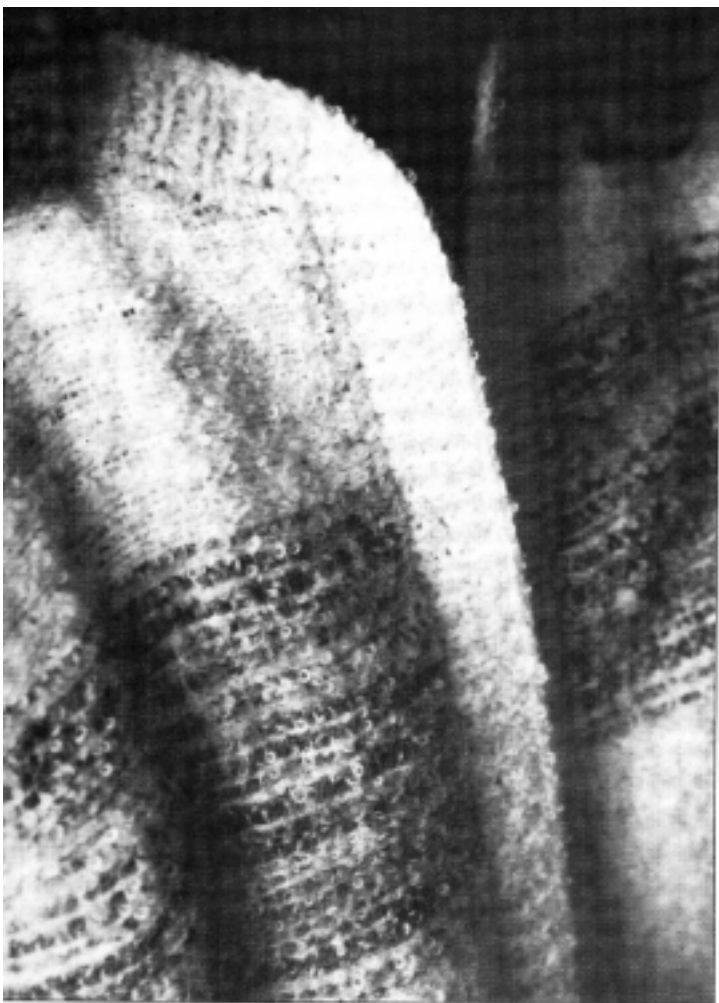

Left: detail of white and purple sweater shown on p. 21.

Below: **Summer blouse.** The warp is a combination of fine cotton and linen threads. The weft is Lily perle cotton with occasional stripes of silk in a point twill pattern. A crocheted edging forms the neck and front button closing and trims the pleated sleeve cap.

Right: details of cotton jacket shown on p. 21. *Photos by Jila Nikpay.*



balance of the fabric (within reason) can be incorporated into the garment body. I must admit that the pleats and gathers in my garments were not always initially intended, but since they incorporated all of the fabric I happened to end up with after weaving and finishing, I added them. This way, I didn't have to cut six or eight inches off my woven piece.

The garment pieces may be joined by hand or with a sewing machine. I prefer using a sewing machine because it creates less obvious seams that blend in well and have little bulk. However, joins such as decorative stitching or crochet are very appropriate.

The neck, sleeves and fronts can be finished with borders or collars and cuffs in knit or crochet. I like to use the same yarns that created the fabric to create these edgings.

Sleeves. My long sleeved garments all have knitted cuffs. These cuffs serve several functions: they gather in the width of the sleeve — anywhere from 18 to 22", and lend a graceful line to the garment. They add additional ease to the sleeve length, since none was built into the length from the muslin and body measurements. Cuffs also keep out drafts and help keep those sleeves out of your dinner, the dishwasher, from being caught in doors, etc.

To create the cuffs, I generally hem the

sleeve edge first or finish it with several rows of machine stitching. Over this base, I work a row of single crochet. Using a set of double pointed knitting needles, I pick up and knit a stitch in each single crochet loop. On the next row, I decrease the stitches to a number appropriate to make a ribbed cuff about 7 or 8" around. (With a gauge of 5 stitches to the inch, I use 36 to 40 stitches. An even number

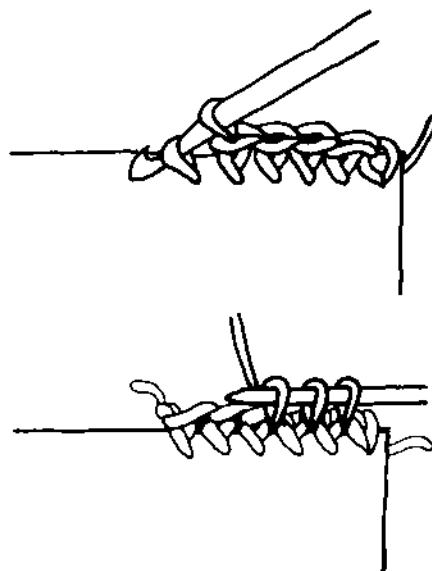

is necessary, so your K1, P1 ribbing will come out evenly.) I knit the cuff to the desired length—usually 2½ to 3" and bind off.

Crocheted cuffs may be worked instead, using a crocheted ribbing stitch.

The front and neck openings may be trimmed with knit or crochet.

For either method I work a base row of single crochet over the raw edges as shown above for the cuff.

To knit the front edge, pick up and knit a stitch in each single crochet loop. A K1, P1 ribbing works out well. I use a long circular needle for this edging so I can knit the fronts and neck at the same time. Buttonholes can be made on the appropriate side front.

A word about fabric

The wrist-to-wrist garment can be made in a multitude of textures, colors and weaves. It is important to design a fabric that won't be stiff and that gives you the loft and drape necessary to make an attractive gathered sleeve.

Because of the need for a good hand to the fabric, I stay away from overshot patterns and warp or weft-faced weaves. All of the garments shown here are woven in tabby. I tend to put the design in the warp using a gamut of colors and textures. This style of fabric design also allows me to explore monochromatic color schemes.

On the practical side, my yarn shelves contain a great variety of yarns—a lot of them are odds and ends. Designing a warp like this allows me to use small quantities of many different yarns to create a substantial project. The weft is generally all one yarn.

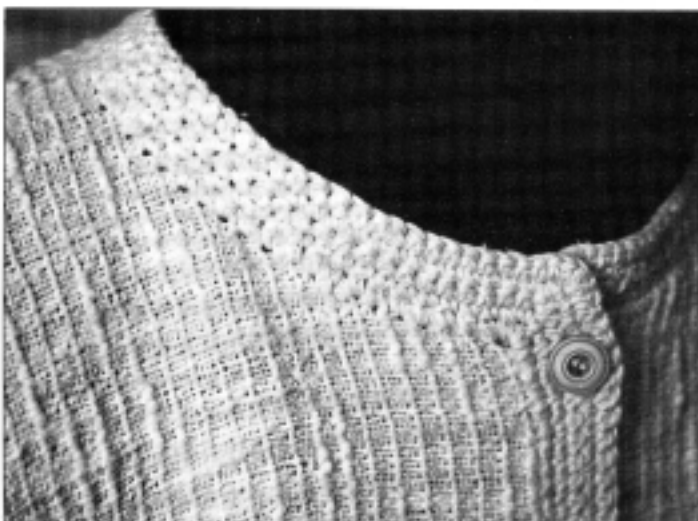

SADYE TUNE WILSON
DORIS FINCH KENNEDY

OF COVERLETS

the legacies, the weavers

A MUST FOR: WEAVERS
TEXTILE STUDENTS
LIBRARIES
HISTORIANS

MUSEUMS
HISTORIC SITES
COLLECTORS

- 496 pages — size 8¼" x 10¾"
- 200 color plates of coverlets
- 350 black and whites of coverlets
- 200 duotones of weavers and homesites with a treasury of family anecdotes
- 400 traditional coverlet pattern drafts, 4-harness
- Unique GRAPHIC MOTIF CLASSIFICATION SYSTEM for analyzing coverlet patterns
- ILLUSTRATED ALPHABETICAL CROSS-REFERENCE of patterns and names to published sources

Price \$50.00 (Retail Only). \$70.00 after Mar. 1, 1985
Postage and handling \$4.00 each; Overseas \$11.00
TN Residents add sales tax \$3.88 each
(Prepay) Total amount. Allow 4-6 weeks for delivery.

order from: TUNSTEDT
Sadye Tune Wilson
212 Vaughn's Gap Road
Nashville, TN 37205 (615) 352-0971

◆ FASHION TRENDS ◆

by Susan Hick

THERE IS STILL TIME to weave your Winter coat before checking out what's new and exciting for Spring. Remember to give it an oversized, slouchier look with bigger shoulders in deep, rich colors.

And then dream of Spring. The general attitude is quite frankly more feminine without being frilly. The so-called androgynous dressing is fading, though its men's wear influence is still felt, especially in fabrics. Clean and soft are the overall aims.

The updated classic suits are more relaxed, even for career dressing. Jackets are loosely constructed for an easy fit and are often fingertip length. They can be without collar, lapels, or buttons. Skirts, whether slim or full, fall to the middle of the shin. Unmatched jackets and skirts, too, are increasingly accepted. These are composed of the usual men's wear fabrics of herringbones, contrasting textured tweeds, plaids, checks, and stripes in season-appropriate fibers. But softness in these comes with the use of pale neutrals and pastels.

Dresses for Spring are reminiscent of styles from the Twenties. The silhouette is long and lean. The blouson is banded at the hip. Vertical pleats trim the front of a dress that again has a band around the hip, this one looser and narrower. When done in two pieces, a tunic sweater or long top slides over a pleated or narrow, trumpet-flared skirt. They are all quite romantic, bringing visions of garden parties and tennis on the lawn.

Sportier wear goes in other directions. Sweaters continue to be favored. Pale Fair Isle inspirations take advantage of the pastels of the season. Another type is short and wide, whether a tank or with sleeves. We can take heart in seeing woven pullovers and polo shirts, even though they do have ribbed knitted trim.

Pants are shorter and baggier, often accomplished by added pleats. No matter what the length—short, bermuda, walking, “city”—shorts are cut boxy and wide enough to resemble skirts. They are worn with camp shirts or tank tops. Those for wear on city streets may be jacketed.

Accessorize with scarves and pouch bags or those little shoulder ones we used to call disco bags.

The colors for this season cover such a wide spectrum that there should be something to please everyone. Best of all, they are colors readily available to handweavers, especially those of us who don't care to haul out the dye pot. They fall into the three categories of light, bright, and dark.

The lights are, of course, pastels. They are variously termed water color, sherbet, or chalky, whitened rather than grayed. Walk around the color wheel and pick your favorites. The blues are aquamarine, sky, and powder. Then there are hyacinth, iris, pale pink, coral, peach, apricot, banana, seaspray, and mint. Of this list the most mentioned are banana, sky blue, and seaspray. It's obvious that they are all clean and pretty, in keeping with Spring's theme.

The brights are bold, vivid, vibrant. Picture turquoise, cornflower, violet orchid, raspberry, fuchsia pink, orange, chrome yellow, emerald, and jade.

The few darks are rich and sophisticated, a palette that includes amethyst, blueberry, bayberry, teal, and brown.

White and natural always come to mind for use in this season. Newer now as neutrals are tans with gray overtones, whether called oatmeal, flax, sand, taupe, or khaki. Black is a sometime accent, not as prominent as in previous seasons.

Mixing all of these together is the easy part. Just pick a neutral and a hue or two. They can be combined by using them “alone together” in separates or by striping them. An interesting way to go is by putting together companion fabrics, one a stripe of two colors (jade and sky blue, for example) and the other a stripe with one of the colors and a neutral (jade and flax). Stripes and plaids, too, can be mixed. Things get really animated when the brights are plaided. It is also perfectly permissible to stay monochromatic with tonal shades of the same color group.

Move on to the yarns and get ready to weave. Surface textures are important, whether accomplished with yarns or weaves or both. The yarns most mentioned are the nubs and the slubs—bouclé, seed, flake, ratine. Textured stripes and mock leno or gauze stripes are good, as are ribbed fabrics. Contrasting colors can be plied and used for raised jaspé stripes. Cotton and linen lend themselves to a tiny waffle as well as multiple shaft piques and openwork weaves. Combining weaves in one fabric makes interesting effects. Try a very highly twisted yarn to produce a crinkled fabric. Linen and homespun looks are possibilities, too. Finally, just as with colors, don't hesitate to mix textures.

For early Spring consider using silk, wool, even a mix of mohair with cotton before turning to the warm weather favorites, cotton and linen. We'll see



• FASHION TRENDS •

more and more ramie. Rayon continues to receive great reviews, adding its iridescence for surface shine in dots and stripes.

Mention must be made here of the return to prominence of prints. Hawaiian and large tropicals in hothouse colors (for shirts and sarong-wrap skirts, naturally), graffiti-look or clean bold letterings (often with amusing messages), soft impressionistics, and florals can inspire many handwovens.

Look ahead to Summer, too. From Europe comes a prediction designed to bring us all up short: hemlines are on the rise. Just wanted to warn you. More midriffs will be bared. We will probably see sleeveless dresses and jumpsuits with full legs, belted and bloused at the waist, with such deeply cut armholes that a bustier or bandeau is required wear underneath.

Turn dreams of Spring into reality now to beat the crowd. And if you prefer to continue to work in the traditional Winter fibers, keep in mind that the trend to lighter, softer, and clearer colors should go into Fall.

**Ask us for
samples of
our specialty yarns
for home and
industry.**

- Rug Wools in many colors.
- Tremendous assortment of Synthetic Yarns.
- Novelty Yarns including nubby earthtones.
- 100% Cotton Yarns galore.

If it can be spun, we're the one.



Wonder Craft

DIVISION OF ROBIN HUG INCORPORATED

1 Constitution Street, Bristol, RI 02809

Tel: (401) 253-2030

Send \$7.00 for samples and a spot on our mailing list.

KAGEDO

JAPANESE KIMONO

Guaranteed Premium Quality
Bales Pre-selected in Japan

Competitive Prices
Limited to supply

Hand Painted, Hand Dyed, Shibori,
Ikats, Embroidery, Fine Silks

Obi Bales and Custom Bales
Available upon request
Call or write for information

KAGEDO

1000 Lenora, Suite 225
Seattle, WA 98121
(206) 467-9077

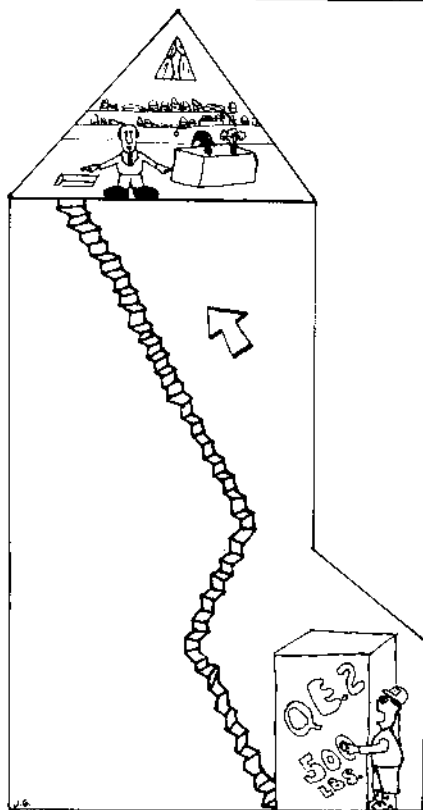

HENRY'S ATTIC
Textured Weft Yarns

5 Mercury Avenue, Monroe, NY 10950
914-783-3930

To see the yarns Henry keeps in his attic,
please send \$10.00 and resale number
for complete sample set. (It's well worth it)

Stores & production weavers only please.

Individual weavers, please see your local weaving or
knitting store, or write for list of stores carrying
Henry's yarns. We appreciate your business.

"You've got to be Kiddin'!"

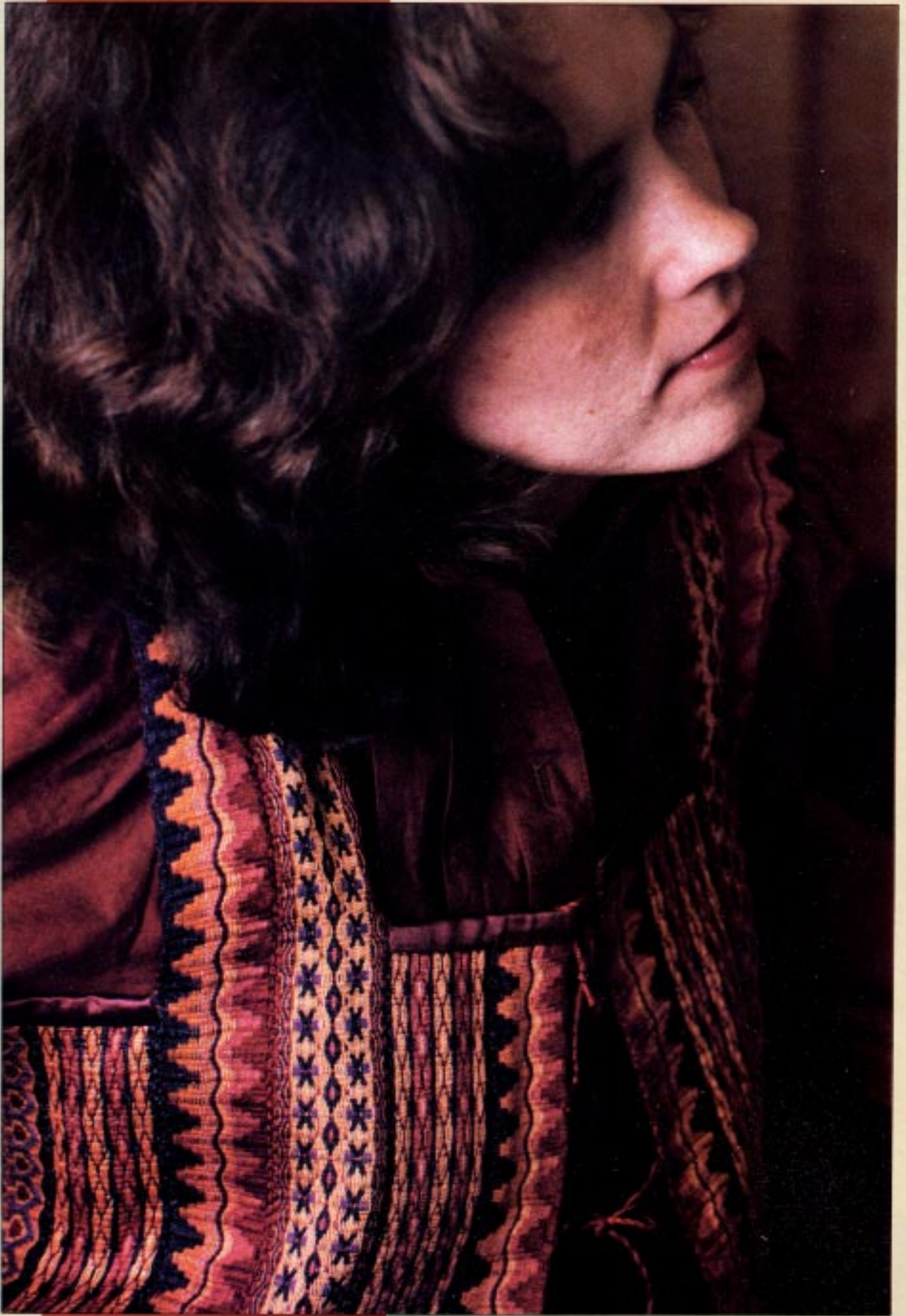

J.A. ARDAY

◆ BEGINNING ◆
WITH ◆ BANDS

Tablet Woven Garments & Accessories

by Marilyn Emerson Holtzer

TABLET WEAVING has long been an interest of mine. Although I have extensively explored both threaded pattern and weaver-manipulated techniques, I must confess that I prefer the intricate patterns of the former to the freer designs of the latter.

My early tablet weavings were of cottons and wools and, like most tablet weavings, became sashes, straps, table mats, etc. However, since my first band of rayon was too delicately patterned and elegant to suffer a similar fate, I decided to weave and join together enough bands to make a full length evening skirt.

The skirt, "Curvature of Chords," contains over 150 feet of tablet woven bands in 10 different patterns. These bands are joined side-by-side on a quarter circle sector. The "new" patterns that are formed when patterns in adjacent strips interact, and the sense of movement that is created by the curvature of the bands (chords of the circle) around the body result in a whole that is greater than the sum of its parts. The effect is reminiscent of both an ancient Egyptian patterned textile and a modern collage-printed fabric. The result inspired me to try other garments and accessories as well.

In this article I will describe how to use slippery, springy yarns such as rayon and silk with a minimum of frustration and failure, and the method of joining the tablet-woven



bands that worked best for me. I will also provide directions for making the skirt, vests and bag illustrated here. Once these basic ideas are understood, other possibilities for using tablet woven bands should suggest themselves to the reader. *Step-by-Step Tablet Weaving* by M. and W. Snow provides a basic introduction to tablet weaving patterns and techniques. Peter Collingwood's, *The Techniques of Tablet Weaving*, deals mainly with weaver-manipulated techniques and contains an extensive bibliography of tablet weaving literature.

Left, tablet woven vest (rayon: Natesh 4502). Photo by Jila Nikpay.

Right, Curvature of Chords. Detail.

Right, Curvature of Chords.
Front view. (rayon: mill ends
and Folklorico "Artisan.")

Below, Curvature of Chords.
Back view. Photos by Martin
Schweig.

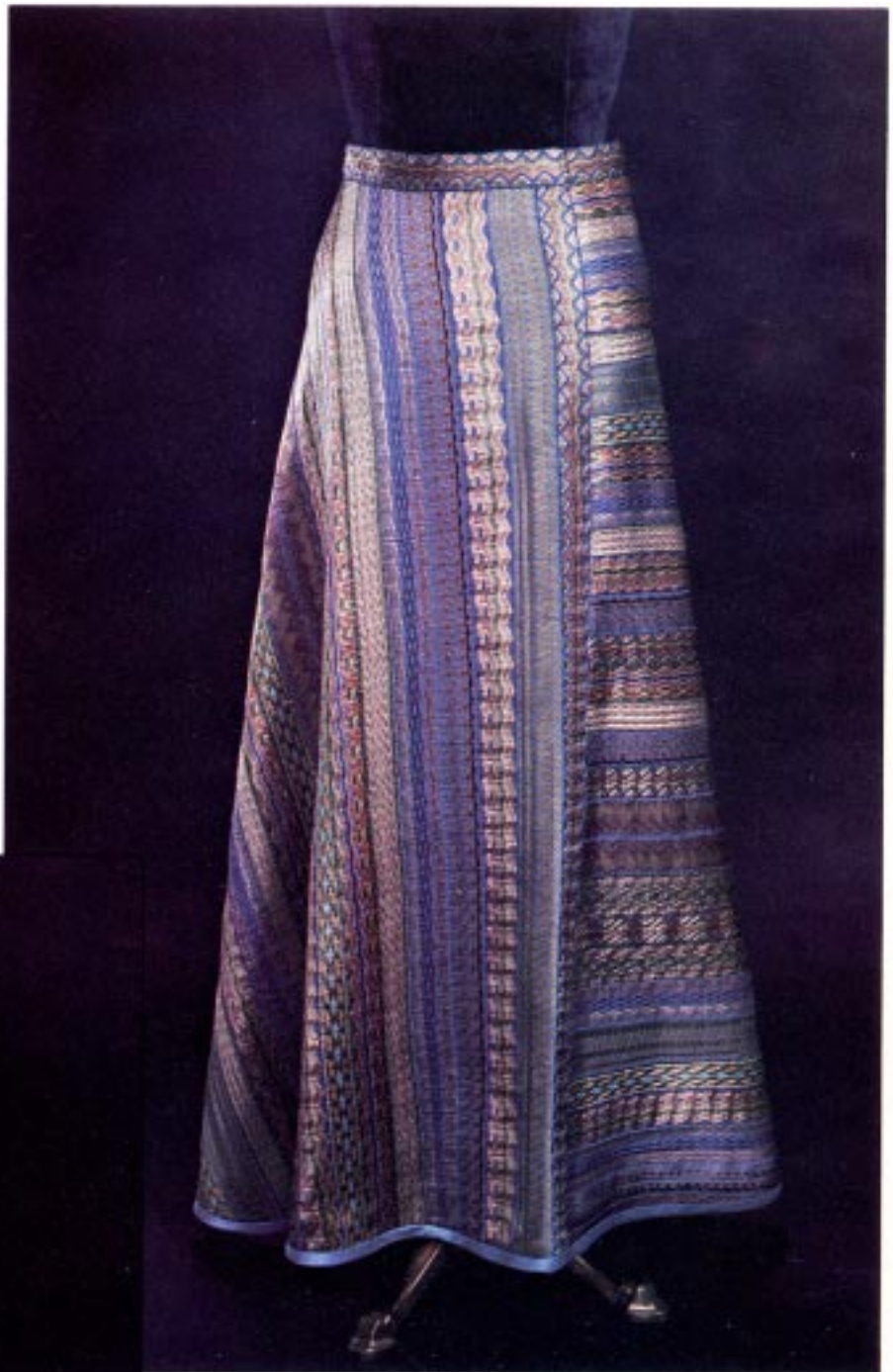

Tablet Weaving with Rayon and Silk

I have used both rayon and silk yarns for the warp. Soft twist rayon (mill ends and Folklorico "Artisan") gives a smooth, lustrous surface, but one that tends to pill if not cared for properly. Hard-twist rayon (Natesh 4502) gives a more textured, less lustrous surface, but one that is easier to care for.

My experience with silk is somewhat limited. Soft-twist, hand-dyed silk resulted in non-distinct patterns and had a dull surface when used for threaded patterns, but produced satisfactory results for some weaver-manipulated techniques. Hard-twist Japanese embroidery silk resulted in a distinct pattern and had a somewhat textured, but lustrous surface. It is available in Japan in a wide range of colors, and is very expensive. To my

knowledge only Natesh is readily available in a wide range of colors.

For the weft I usually use perle cotton. It is strong, yet soft, and comes in a wide range of sizes and colors. The weft should be no larger than the warp so that the pattern retains its fine detailing. If the weft is pulled tightly enough to keep the warp from slipping around, and matches the selvedge warp's color, it will hardly show at the edges of the band.

Tablet weaving with rayon and silk requires a great deal of care and patience, largely because it is extremely difficult to tie secure knots in these slippery yarns. I usually set up the tablets on an inkle loom using a false circular warp. After threading each card and passing the warp around the posts of the loom, I tie the ends together with a slip knot in front of the front post. After all the cards are warped, I readjust the tension of the threads from each card, then tie a square knot. The tension often has to be readjusted during the weaving. Allow more time for warping and weaving when using silk and rayon.

Joining Bands

Decide what you're going to make and choose or design a pattern for it. When making a garment, however simple, first cut a muslin pattern and perform any necessary fitting adjustments on it. Then cut a backing of lightweight, non-stretch fabric from your adjusted muslin pattern. Seam allowances should be added only where edges overlap, (e.g., waistline of skirt) or abut (e.g., side seams of vest). Determine the area to be covered and weave about 25% more bands than required to cover it.

Before cutting the bands, decide how they are to be arranged on the backing and securely stay-stitch $\frac{1}{4}$ " on either side of the cutting lines. Fuse the selvages of adjacent cut bands to the backing using $\frac{1}{2}$ " wide Stitch Witchery™. Be careful not to fuse the selvedge of any single band to an outer edge of the backing. Hand or machine stitch adjacent fused bands to the backing. A machine joining stitch works well except when joining two bands having very different colors along their selvedge.

Vest Construction

The basic pattern (without seam allowances) for the vest (size 8-10) is given in Diagram 1. The area to be covered is 544 square inches. All tablet-woven bands are to be placed parallel to the arrow.

Cut backing; add seam allowances to the back side seams. Start at the center back and fuse the first two bands to the backing. Attach

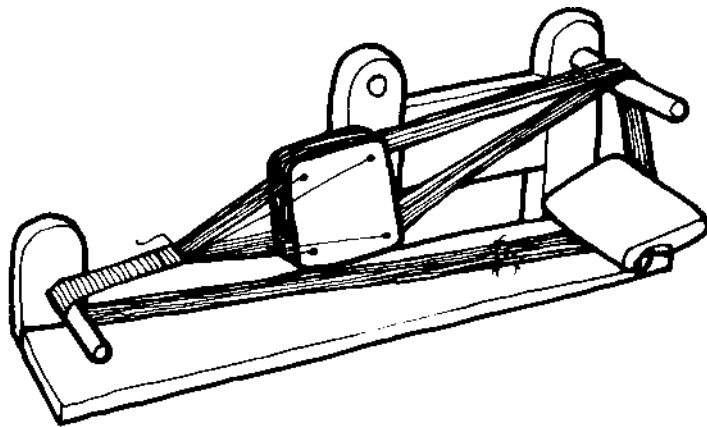

successive bands immediately adjacent to and parallel to preceding ones until the "center back" section is covered. The outermost bands need not be continuous with the neck opening (there is about $\frac{1}{4}$ " leeway).

Attach the innermost bands of the "over-the-shoulder" sections immediately adjacent and parallel to the outermost bands of the "center back" section. Make sure they are parallel to the arrow throughout their entire

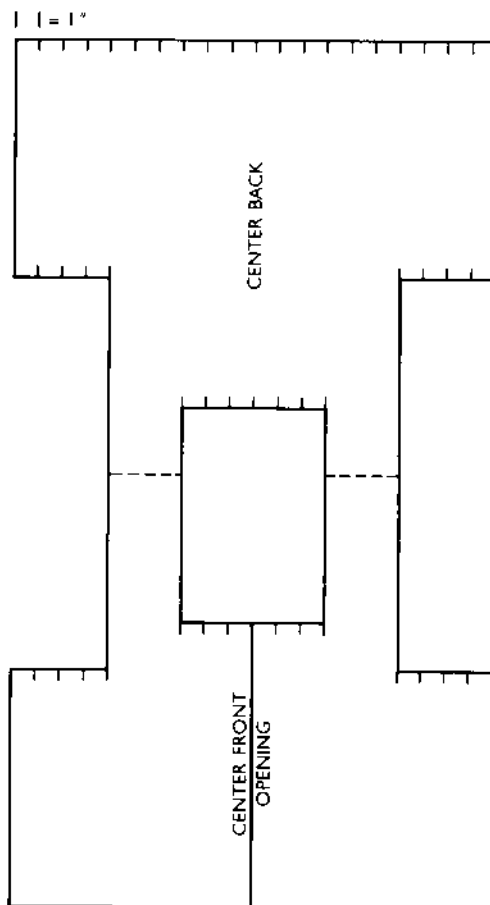

Diagram 1

lengths. Fill in the remainder of the "over-the-shoulder" sections. Then, fill in the "side front," "side back" and "center front" sections, beginning each at the "over-the-shoulder" section and working away from it. Place the outside edge of the last band in the

"side back" section along the seam line; make sure it does not extend into the seam allowance. Extend both "center front" sections beyond the center front edge of the backing to give the necessary extra width across the vest front. Fold at the shoulder (dashed) line; abut the side front and side back bands and fuse them to the backing.

The cut edges (perpendicular to the arrow) will need to be finished. If necessary, trim (after stay-stitching) to make them straight; then machine stitch, using a 1/4" seam allowance. The selvedge edges (parallel to the arrow) require no finishing. However, if necessary, trim the backing so that it does not extend beyond them.

Fold the adjusted muslin in half along the center line and use it as a pattern to cut two pieces of lining; add seam allowances all around. Since a narrow band of lining will show on the outside of the vest, use a suitable fabric such as satin. Sew center back seam; press open. Place the tablet-woven vest face on the lining with the wrong sides together. Mark on the lining all inside corners. Mark directly along selvedges, but 1/4" inside cut edges (Diagram 2). Reinforce lining corners with machine stitching. Clip to corners. With wrong sides together, machine stitch tablet woven vest face to lining, using 1/4" seam allowance. Turn under all lining seam allowances along selvedges, press, and hand stitch to bands. Trim other lining seam allowances even with cut edges. Encase cut edges with straight or bias lining fabric.

Evening Skirt Construction

The basic pattern for the evening skirt (size 8-10) is given in Diagram 3; it includes a 1" seam allowance along the waistline and along the radius perpendicular to the arrow. The

Diagram 3

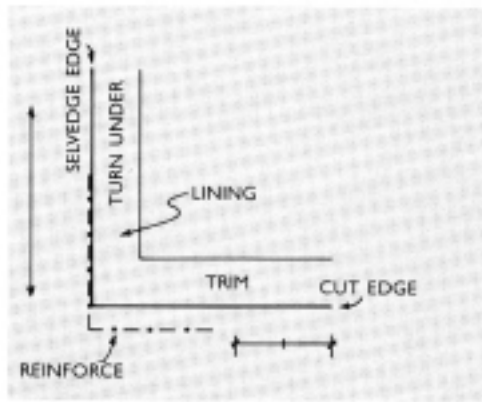
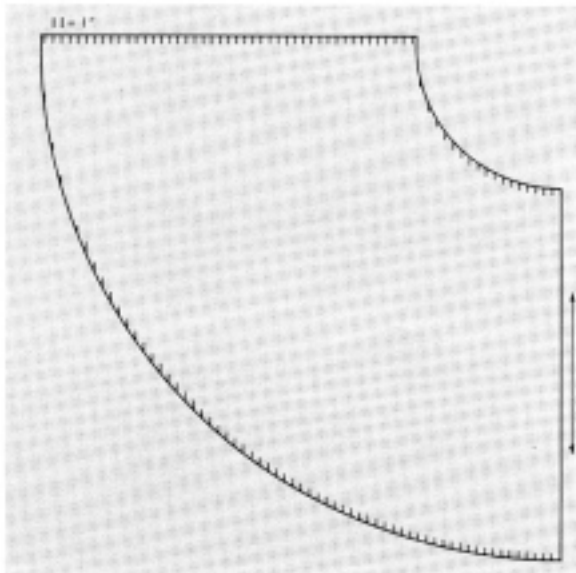

Diagram 2

area to be covered is 2,900 square inches. All bands (except the waistband) are to be placed parallel to the arrow. The selvedge of the first band will extend from the waistline to the hem along the radius parallel to the arrow; the cut edges of several other bands are placed along the radius perpendicular to the arrow. The "curvature" occurs when these two radii are brought together.

Since all the bands will differ in size and shape, it is easier to stay-stitch, then cut each band after it is attached to the backing, rather than cut all the bands in advance. It will probably be necessary to ease the waistline. Since tablet weavings usually vary in width, this can be done by placing narrower sections of the bands at the waistline and making tiny darts in the backing between adjacent bands, and/or easing the waistline onto the waistband. After all the bands are attached, the cut edges should be trimmed (stay-stitch first if necessary) to make them even.

To line the skirt, cut lining, according to Diagram 3; add 1" to both radii (piece if the fabric is not wide enough). Place the tablet-woven skirt face on the lining with the wrong sides together. Turn under lining seam allowance along radius parallel to arrow; press; trim; hand (slip) stitch to tablet-woven band selvedge. Machine stitch lining to skirt face at waistline and hemline; make sure no slippage occurs. Fold the remaining lining seam allowance back over the cut edges of the bands (perpendicular to arrow); turn under 1/4" at the edge; press; then stitch to completely encase the cut edges of the bands.

Bring the two radii together; place the selvedge radius flat on top of the (encased) cut edge radius, overlapping to cover the encased edge. Insert a 7-9" zipper. Stitch from the bottom of the zipper to the hem. Cut tablet-woven waistband 2" longer than desired length; interface. Cut waistband lining; add seam allowance all around. Machine stitch lining to right end of waistband; turn back; press. Turn under top edge of lining; press; and hand (slip) stitch to band.

Machine stitch waistband to skirt waist-

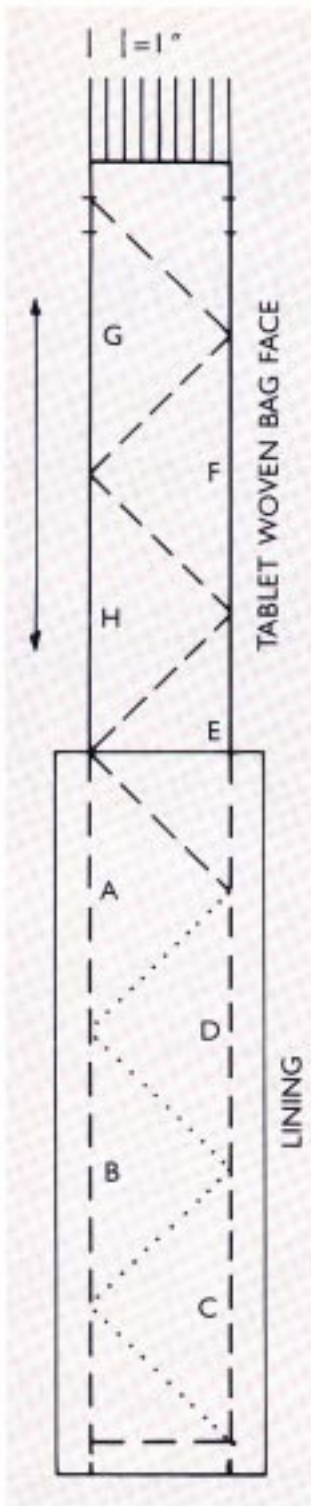

Diagram 4

line. Encase left end in lining material. Turn under bottom edge of waistband lining and slip stitch to skirt at waistline. Sew snaps or hooks and eyes to waistband. Adjust hemline. Encase bottom edge in bias strip of lining fabric.

Bag Construction

To make the bag face, finish the fringed ends of the tablet-woven bands as desired. Join the bands side-by-side onto a backing so that the length, excluding the fringe, is four times the width plus $1\frac{1}{2}$ ". The backing should extend only to within 1" of the fringe. Thus, if the width is 4" the length of the backing should be $16\frac{1}{2}$ ", and the length of the face should be $17\frac{1}{2}$ " plus the length of the fringe.

Cut lining of length five times the width of the bag; add 1" all around. In the example above, the lining should be 6" wide and 22" long. Sew the end of the lining to the cut edge of the bag face to form a long narrow strip (Diagram 4). Press both seam allowances ($\frac{1}{2}$ " on bag face; 1" on lining) toward lining. Turn under and press lining seam allowances along long edges.

The dashed and dotted lines on Diagram 4 show the bag and lining fold lines. Folds along the dashed lines are with the right sides of the fabric out; folds along the dotted lines

are with the wrong sides out. Form the lining first, wrong side out. Bring sides *a* and *b* together and machine stitch. Fold along dotted lines to form a triangular section with apex opposite side *d*. These two folds are the first two sides of the square bag. Trim seam allowance and press open. Next bring sides *c* and *d* together and stitch. Fold along dotted line to form the third side of the square bag. Trim seam allowance and press open.

Next, form the bag, right side out, around the lining. Fold lining along dashed line (right side out) near junction of bag face and lining. Fold bag face along next two dashed lines to bring sides *e* and *f* together. Join band selvages by hand. Fold again to bring *g* and *h* together. Join band selvages by hand. Turn under lining seam allowances on flap. Stitch lining flap to bag flap. Add snap if necessary.

Bibliography

- Collingwood, Peter, *The Techniques of Tablet Weaving*. New York: Watson-Guiprill, 1982.
- Holtzer, Marilyn, "Diagonal Triple-turn Cardweaving," *Shuttle Spindle & Dyepot*, Vol. XII, No. 2, Spring, 1980.
- Holtzer, Marilyn, "Double & Double-faced Cloth on Six-Hole Cards," *Interweave*, Vol. V, No. 2, Spring 1980.
- Snow, Marjorie and William, *Step-by-Step Tablet Weaving*. New York: Golden Press, 1973.



Natesh rayon is available from Mar-Car Products, P.O. Box 2489, St. Louis, MO 63130.

Tablet woven bag (untitled). (rayon: Natesh 4502.)

Applying the Pulled Warp Technique to Loom-Shaped Clothing



by Kerry Evans

MATHEMATICS, including geometry, was not the highlight of my learning experience in school. Now I find myself totally immersed in the geometric principles dealing with the properties and measurements of points, lines, angles, surfaces and solids. Mr. Zanetelli, my math teacher in high school, would be so proud knowing that after 24 years his teachings were finally put into practice.

When designing clothing using the pulled warp technique, one works with placement of lines, angles and curves to create the difference between the flatness of fabric and the sculptural three dimensional shape of the human form. By leaving designated angles and areas in the warp unwoven and then, upon completion of weaving, pulling the warp threads to close the open area, this technique enables the weaver to de-

sign a loom-shaped garment which is fitted to the body. Some of the most useful ways to use these angles are at the shoulders, the bust line, tapering sleeves, flaring skirts, curving collars and neck lines, and making belt loops and pockets. Wherever there is a need for shaping, this versatile technique can be applied.

First and foremost, I am a designer. Weaving is a valuable extension

of the creative process necessary in completing my garments. I love to weave and take so much enjoyment watching my creation grow. My loom is the tool through which I bring my design to life. By using the pulled warp technique, I am able to use my loom to the fullest. Not only does it weave the fabric, it shapes, fashions and forms the garment, thus eliminating nearly all cutting and sewing. Final construction is minimized and usually sewn by hand as are most seams on selvedge edges.

This technique offers a challenge unlike any other as far as loom-shaped clothing is concerned. Many things must be taken into consideration. Designing, of course, is the most difficult part. Correct size and placement of the angles is imperative. My designs are worked out in four stages. First comes a detailed sketch with a written description of the garment. Next, I make a three dimensional model to scale from graph paper. All open areas, often referred to as "darts," are cut out and secured with transparent tape, as are all seams. Every detail of the design is included on this model. Pieces fit together like a puzzle. Third, I draw out a layout or pattern on graph paper showing the exact measurements of each piece. Last of all, to ensure a perfect fit, I make a sample garment from muslin. Any correction or change is then noted on the layout.

Selection of weaving materials is

extremely important for the success of a pulled warp garment. The warp, which I usually sett at 15 ends per two inches, must be a smooth, strong thread in order to withstand the pulling. I use a variety of threads such as 10/2 cotton, 2-ply wool/silk blend and various kinds of synthetics. Any fiber can be used as long as it is strong and has no frayed or knotted areas.

The weft is as important as the warp. Since pulling can distort the weave, it is best to chose a yarn that minimizes or hides the distortion. Any yarns which are knobby, thick and thin, variegated or textured work well in distracting from the distortion. Often, I alternate two types of yarn. For example, "Queen Anne's Lace" from Henry's Attic alternated with chenille is very successful. Or, a 2-ply wool alter-



Above. Vest, synthetic warp, Dordogne weft by Kerry Evans.

Opposite. Kerry's prize-winning cape coat shaped with the pulled warp technique.

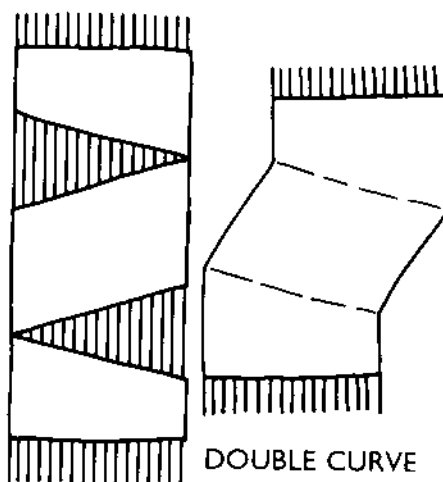

weaving. It can be difficult to maintain the same beat when weaving an angle. The closer one comes to the vertex of the angle, the more careful one must be. If beaten too hard, the angle will squash down and become misshapen. Using a tapestry fork or comb is a good solution. Tension can also be a problem. A filler may be used in the open areas. Sometimes, I choose to cut off after several pieces have been woven and then re-tie the warp. Occasionally, I will also pad the front beam with towels to help alleviate the problem.

When weaving more than two angles in one piece, it is necessary to

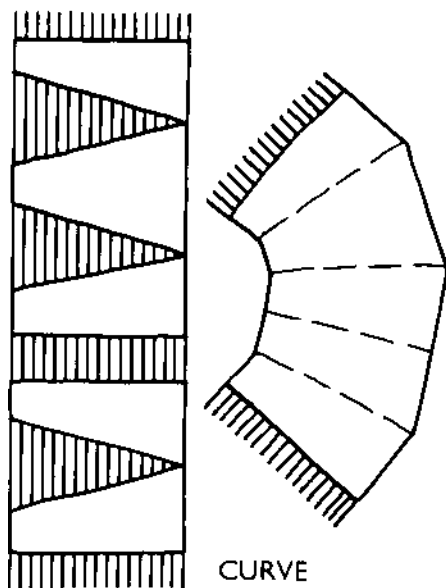

nated with a heavier tweed or homespun such as Tahki "Donegal" is a good combination. The result when alternating thick and thin threads is a definite rib weave. Again, due to the distortion, it is advisable to use a plain (tabby) weave or weft-faced weave. A patterned area or border could be used where the warp threads will not be pulled. Stripes are very effective when using this technique.

The size of the angle and thickness of the weft will determine the number of warp threads to pass over when weaving. Experiment! There is no absolute rule. Weave over the same warp threads twice, or pick up three or four or more warp threads in each row to achieve the desired angle. Before starting to weave, make a paper template of the areas to be left open. Use this as a gauge to obtain the correct angles of the darts while

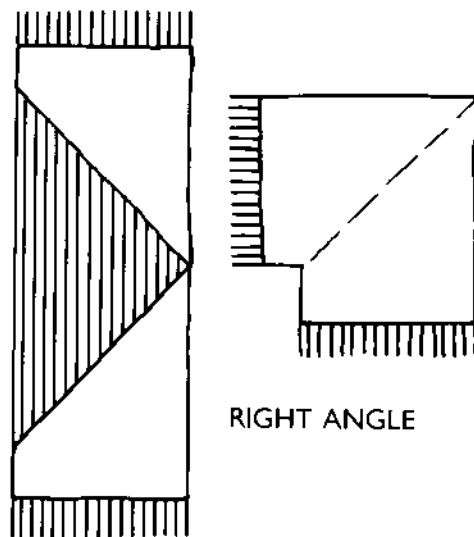



JILA NIKFAY

Cape Dress. Cape and skirt are shaped by the pulled warp technique. The warp is hand-dyed 10/2 cotton. Weft is Majesty rayon from Silk City Fibers.

leave a 2" open area between two of the darts. The function of this 2" open area is to enable one to grip the warp threads in order to pull the angle closed. Figure 3 is an example of when this is necessary.

Pulling the warp threads, which

seems the most laborious stage of this technique, is actually the most exciting. As each thread is pulled, the flatness of the fabric, with all its open areas, transforms itself into angles and curves, thus beginning a three dimensional shape. The garment takes form as each warp thread is manipulated.

The technique is very simple and not as time consuming as one may think. Of course, each thread is pulled in sequence and then pulled a second

time to even the closing. It is not necessary to weight down any portion of the fabric when pulling. One's hand, placed at the area where the pulling is being done, produces a sufficient amount of pressure. Always pull from the same side of the fabric. There is a definite right and wrong side to the fabric after pulling is completed.

Mastering the pulled warp technique takes time and practice. Before beginning a garment, I suggest making samples to practice not only weaving the angles and pulling the threads but also experimenting with various fibers to learn which are best suited for this technique. Figures 1 through 4 are basic examples of commonly used angles, each showing the weaving before pulling and the end result after pulling. (The belt loop can be extended to form a pocket with a flap.) Any angle or shape can be woven.

Designing and weaving loom-shaped garments is for me a challenging passion. In my first book, *Treadled Togs*, I took loom-shaped clothing beyond the "bog" stage by using rectangles in a more fitted and stylish manner. With the pulled warp technique, I can continue designing with rectangles, which are synonymous with loom-shaped clothing, and develop an even more unusual garment. The rectangle remains a four sided plane with four right angles until the surface is altered by manipulating both warp and weft to form curves and angles. The possibilities and uses for applying this technique to loom-shaped clothing are endless. It's fun, it's intriguing and the end result is gratifying. Not to mention that it cannot be done by machine!

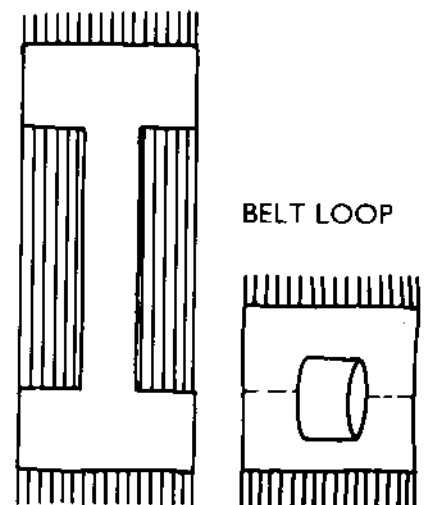

Shuttle SPINDLE & DYE POT

Quarterly for weavers, spinners and dyers published by the Handweavers Guild of America.

Membership Rates
One year \$18
Two years \$35

Add \$2 per year outside of U.S.A. U.S. funds drawn on a U.S. bank. MasterCard/Visa accepted.

Send name and address with check, money order or credit card number and expiration date to:

HGA Membership-WJ
65 La Salle Road
West Hartford, CT
06107 U.S.A.
(203) 233-5124



Handweavers
 Guild of America

The Silk Tree

26727 FERGUSON AVENUE, WHONNOCK, B.C., CANADA V0M 1S0

Over 40 quality silk yarns and fibres
mail order samples \$3.00
 wholesale and retail

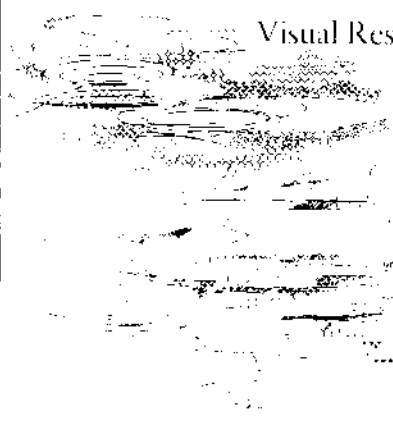

Visual Reservoirs: In - of - under - about Surface

Surface Design Association National Conference
 March 19-22, 1985
 Astoria Conference Centre, Bay 66 Grove,
 On the Monterey Peninsula, California

Co-sponsored by the Department of Environmental Design, University of California, Davis

The prospectus and registration information will be sent LHM and a January 15, 1985 deadline for registration. Write to: *Surface Design Association Journal* for more information, or write:

Kerry Evans
 Department of Environmental Design
 University of California, Davis
 Davis, CA 95616

The best in textile and art weave yarns from Finland

HELMU VUORELMA

- Wool Blanket Yarn (Brushable)
- Loop Mohair (Brushable)
- Raanu Yarn
- Superwash Marja-Riitta
- Takana Finnweave Yarn
- Ryjy Yarn
- Tow Linen & Transparency
 Linen (1 card)
- Cotton Chenille (1.7)
- Seine Twine
- 20/2 Cotton
- 12/2 Cotton
- 8/3 Cotton

Cotton Poppans from Pirkanmaa
 Toika Looms and Equipment

Sample cards \$1 each or 6 for \$5



Schoolhouse Yarns
 25495 S.E. Hoffmeister Rd.
 Boring, Oregon 97009
 503/658-3470

Mail order only.
 Wholesale and Retail.

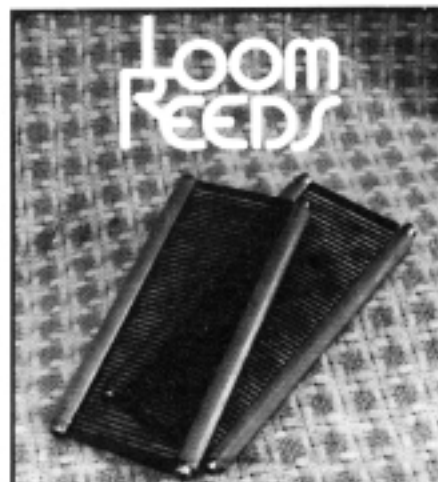

Made to your specifications,
 carbon or stainless steel, any
 dents per inch, lengths and widths.
(Metric Reeds also available.)

Write For price list:

BRADSHAW MANUFACTURING CO.
 P.O. Box 5645
 West Columbia, S.C. 29171-5645
 (803) 794-1151

APPLYING THE PULLED WARP TECHNIQUE TO LOOM-SHAPED CLOTHING

BY
**KERRY
 EVANS**

A PORTFOLIO
 FEATURING 8 DESIGNS
 \$8.95 + .75 postage

Kerry Evans
 2308 East Euclid Ave.
 Milwaukee, WI 53207

NEW FROM LECLERC

Leclerc's no-fault Dobby weaving loom

Featuring an integrated 12-harness Dobby system fitted with a four-bobbin flying shuttle allows for speed and accuracy by eliminating common faults due to speedy execution.

1) This new Dobby system controls the movement of the harnesses according to a predetermined program set by guides inserted over the warp. Impossible to make a mistake, no matter how complicated your pattern might be and no matter how experienced the weaver might be. The work gets done fast and impeccably.

2) The new multibobbins flying shuttle is easy to manoeuvre. You may change color or thread by simply pulling the suspended handle positioned in front of the operator.



Leclerc's Dobby system and the multibobbins flying shuttle integrated into this loom can also be fitted separately on any Leclerc Colonial weaving loom.

Leclerc
SINCE 1876



For detailed literature about this new Dobby loom and for the list of authorized Leclerc dealers in your area, simply fill-in this coupon and mail to:
LECLERC CORPORATION, P.O. Box 481, Plattsburgh, NY 12901 U.S.A.

Name _____

Address _____

City _____

State/prov. _____

Postal/zip code _____

An Ounce of Prevention

Methods for mounting

by Mary Ann Butterfield and Lotus Stack

THE COMPLETION OF a textile by the artist is the beginning of its life in an alien world where even under the best of circumstances it will be subjected to stressful and damaging situations. The first article of this series pointed out how the materials and structure of a fiber piece are controlling factors in its life expectancy. Assuming that these have been chosen with as much care as design and aesthetics allow, the next consideration is a method of display that will support the structure and protect fibers from the inevitable onslaught of people and environment.

The manner in which a textile is mounted and installed bears directly upon its life span since structural stress and abrasive movement are major causes of deterioration. In addition, environmental factors break down fibers in various ways. Both in the home and in public buildings dust, smoke, food preparation, climatic changes, lighting and, in fact, the very presence of breathing human beings, speed disintegration.

It is an obvious immediate benefit to the artist and to the client that the presentation of a fiber work shows it to advantage. No matter how beautifully designed and well executed, artistry and craftsmanship are lessened by careless mounting. Over the long term, when the production of today's fiber artists may become valuable as historical evidence of our time, these textiles will not exist unless cared for now. Thought should be given to the future as well as to the present. While artists have no control over the handling of an object by future owners, they can at least assure that it begins life with a display system in which

aesthetic considerations work in harmony with physical stability to keep the textile looking its best as long as possible.

Space here does not permit dealing with the many forms a textile might take, so we will limit this discussion to flat and three-dimensional pieces that are planned for vertical display. This must also be a general discussion since no one method is appropriate for all textiles. The selection of a particular system depends upon the form, weight and structure of the individual piece as well as the presentation desired. A large wool tapestry would require sturdy materials to support its weight while lighter materials would be used for a delicate shawl.

Though the theory is similar for most free hanging textiles, the actual system varies with each. In all cases physical stability is of utmost importance, and to achieve this the weight of the textile—the downward pull as it hangs in the vertical position—must be evenly distributed. In addition the original alignment of the basic structure—the perpendicularity of warp and weft—must be maintained. Thought must also be given to protective measures such as linings, frames and Plexiglas™ boxes. These prevent abrasion against walls, and protect from chemicals in construction materials, light, dust and air pollution.

It is convenient and generally acceptable to display certain textiles by means of a hanging system along the reverse upper edge. Two methods currently in use in museums are the Velcro™ heading band and the constructed sleeve. When made of materials compatible

Structural stress and abrasive movement are major causes of deterioration.

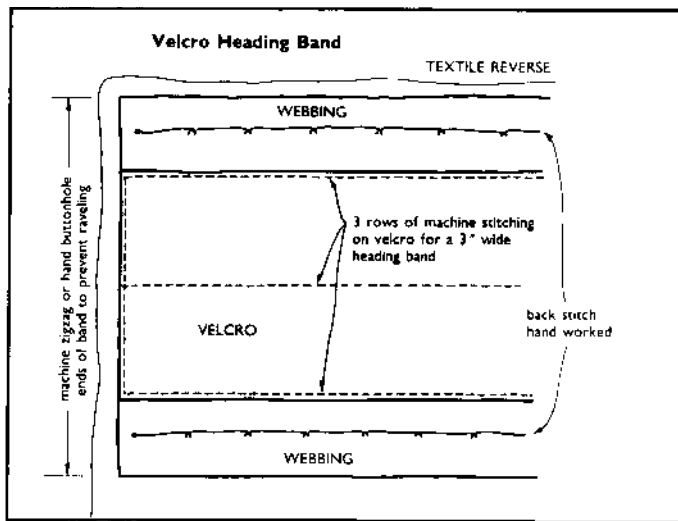

with the textile and when correctly applied, each fulfills requirements for the needed consistent support.

To construct a Velcro™ heading band for a large heavy piece, such as a tapestry, a two inch wide strip of Velcro™ (soft side) is machine stitched to a three inch wide band of cotton webbing. Assuming that the textile will hang with the warp in the vertical position, the completed heading band is laid along the reverse upper edge of the textile and basted in place. It is critical for proper hanging that the heading band be placed absolutely perpendicular to the warp threads. The textile is then turned face up and the band is hand sewn to it using two rows of back stitch—one along the upper edge of exposed webbing and the other along the lower edge. Stitches are not made into the Velcro™ as the force required to pierce its dense structure makes needle control impossible, causing abrasion and stress to the textile.

A small tapestry needle is used to apply the heading band. Its blunt tip will pass more easily between warp and weft without piercing them. A single strand of cotton carpet thread is used for the backstitching because it

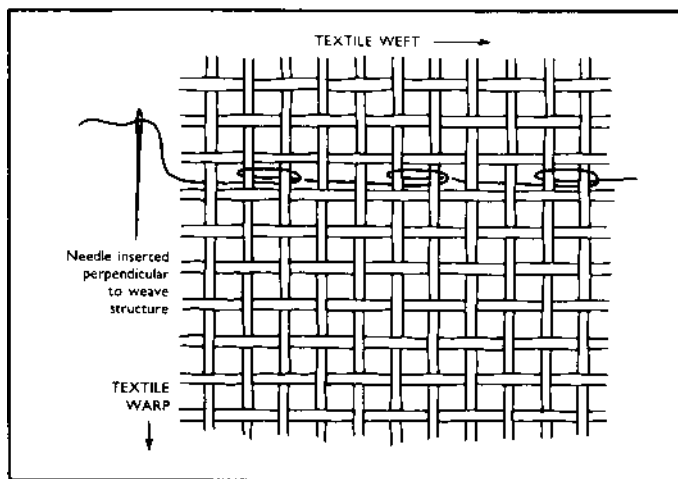

is strong enough to bear the weight, yet soft enough not to cut fibers. Sewing begins in the center of the textile and moves toward each edge so that the basted alignment of the band is more readily maintained. The stitches are made by inserting the needle perpendicularly between the warps taking care not to pierce either warp or weft. The thread is pulled all the way through on the reverse before being returned to the face. This is a two-part movement which maintains total control of needle and thread. The short overlap portion of the back stitch wraps around one or more warps depending on the weight-supporting capabilities of the individual warps. The securing stitches should be 1/2 to 3/4 of an inch apart so that the weight of the hanging textile is distributed evenly across the upper edge with the downward pull held by the warps.

To complete this hanging system a wooden slat is covered with three coats of polyurethane varnish and sanded smooth. Poplar is the preferred wood as it is low in resin; polyurethane is considered to be an inert substance and it seals wood acids away from the textile. The toothed side of the Velcro™ strip is stapled to the finished slat, and rings, screw eyes or hooks are fastened to the reverse, the ends or the upper edge for attachment to the wall. When the soft side of the Velcro™ that is sewn to the textile is pressed against the Velcro™ on the slat a bond is formed that will safely hold the specified weight. Here again it is critical that the warps remain perpendicular to the slat as the bond is made, so that the basic alignment of the textile remains true. Otherwise the hanging will be askew causing harmful diagonal stress as well as unattractive rippling. If distortion is prolonged, permanent damage will result visually as well as structurally.

A variety of sizes and weights of textiles can be hung in this manner by choosing appropriate weights and widths of materials for the heading bands, and slats that are strong enough to prevent sagging.

A second method of hanging is the sleeve. Often a sleeve is thought of as a strip of fabric or tape sewn to the upper reverse edge of a textile with a round wooden or metal dowel slipped through for attachment to the wall. This, however, does not give structural support, as the textile can slip forward on the round dowel and hang unevenly; nor is it protected from wood acids, metal oxidation, nor from abrasion against the dowel. The sleeve should be constructed of cotton fabric to fit completely around a rectangular wooden slat. Cotton fabric (muslin, duck or canvas chosen to accommodate the size and weight of the textile) is machine stitched into a tube shape. The slat (also chosen according to the size and

weight of the textile) should fit into the tube with enough fabric left over to form flanges on each side for sewing to the textile. The tube is tailored to fit the slat and the flanges are formed by inserting the slat into the tube, pressing the excess fabric down along each side of the slat and pinning it in place. The slat is removed and the sleeve is machine stitched along the pin lines. (see drawing) The fit should be snug enough to prevent the sleeve from being pulled forward by the weight of the textile but loose enough to allow the slat to pass through easily.

The sleeve is sewn to the textile in exactly the same manner as the heading band described above. The wooden slat is also prepared in the same way. The result, when the slat is in place, is a sturdy rigid support along the upper edge of the textile which allows evenly dispersed downward pull while hanging. Since the sleeve encloses the slat, the textile is protected from abrasion. The fabric used for the sleeve should be washed to remove sizing and finishing chemicals as much as possible. Since it cannot be seen from the face, undyed fabric should be used to eliminate concerns about dye content and bleeding. The sleeve fabric must be carefully ironed after washing so that its weave structure is realigned; otherwise the sleeve will twist and cause difficulty in tailoring to fit the slat.

The advantages of the velcro heading band are ease of construction, ease of adjustment and ease of installation. There are two important disadvantages to this system. One is the possibility of misalignment of the velcro bond, that is, the perpendicular relationship of the warp to the slat, which would destroy the warp/weft position. Of even more importance is the temptation to break the bond too roughly and thus severely damage the work of art. With the sleeve, no adjustments can be made. However, this indeed is its advantage for no one can come along and distort the correct alignment which was established when the sleeve was applied. The real disadvantage is the unforgiving nature of a misapplied sleeve. In all cases the slat must remain rigid under the weight of the textile.

Whether hung from a heading band or from a sleeve, weighting along the lower edge is not recommended. While this may at the moment improve the appearance of a textile that does not naturally hang flat, over the long run it will speed deterioration by stretching the warp and placing excessive stress on the weave structure.

A round dowel is an appropriate means for hanging a three-dimensional piece such as a kimono shape with sleeves or a large soft textile that is to be folded or draped. The dowel can be wood, coated with polyurethane, or it

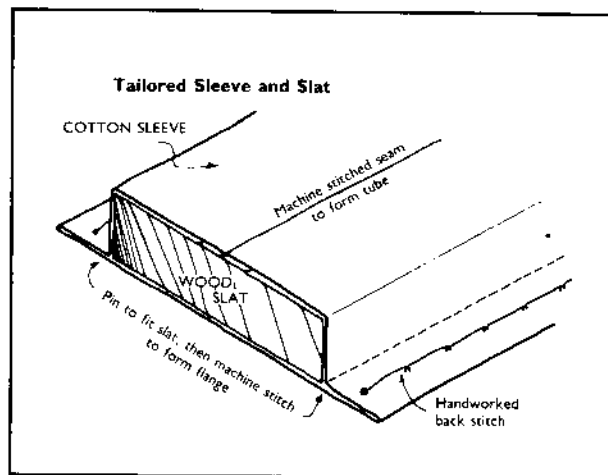

can be Plexiglas™. It must be large enough to bear the weight of the textile without sagging, and long enough to support the piece to its outer edges. The entire dowel can be encased in fabric if this would be visually more attractive. If not, then at least the unseen area of the dowel from which the textile will hang should be covered and lightly padded. The covering creates a surface that prevents the textile from slipping askew and from abrading against the round shape. It also provides a soft, springy base for the fibers while the textile's weight pulls down against it. If the textile has a shape other than perfectly straight at the contact point, such as a costume with shaped shoulders, the dowel must be padded to fit. For extreme shaping a form can be cut from wood or Plexiglas™ or an armature made from some other material and padded to the correct shape. Always the material used for the hanging system must be compatible with the size and weight of the textile, and consideration must be given to the content of the materials and how they will react to the environment over time. The textile must be buffered from such things as wood acid, metal oxidation and chemical breakdown.

Certainly all fiber art will not be designed in a perfectly true warp/weft direction. If it were, the art of weaving would be lost to pure craftsmanship and monotony would reign. The point to be made here is that as the structure moves away from perpendicularity for the sake of artistic creativity, strength is reduced and life is shortened. Whether in the weaving or in the mounting, the artist should be aware of the compromises and their short and long term effects on the work.

The life span of a textile that can be mounted in an enclosed system is likely to be longer than that for a free hanging piece. The next article in this series will consider more protective mounting systems, ways to control the environment, as well as the artist's responsibility to the gallery and art collector.

As the structure moves away from perpendicularity for the sake of artistic creativity, strength is reduced and the life is shortened.

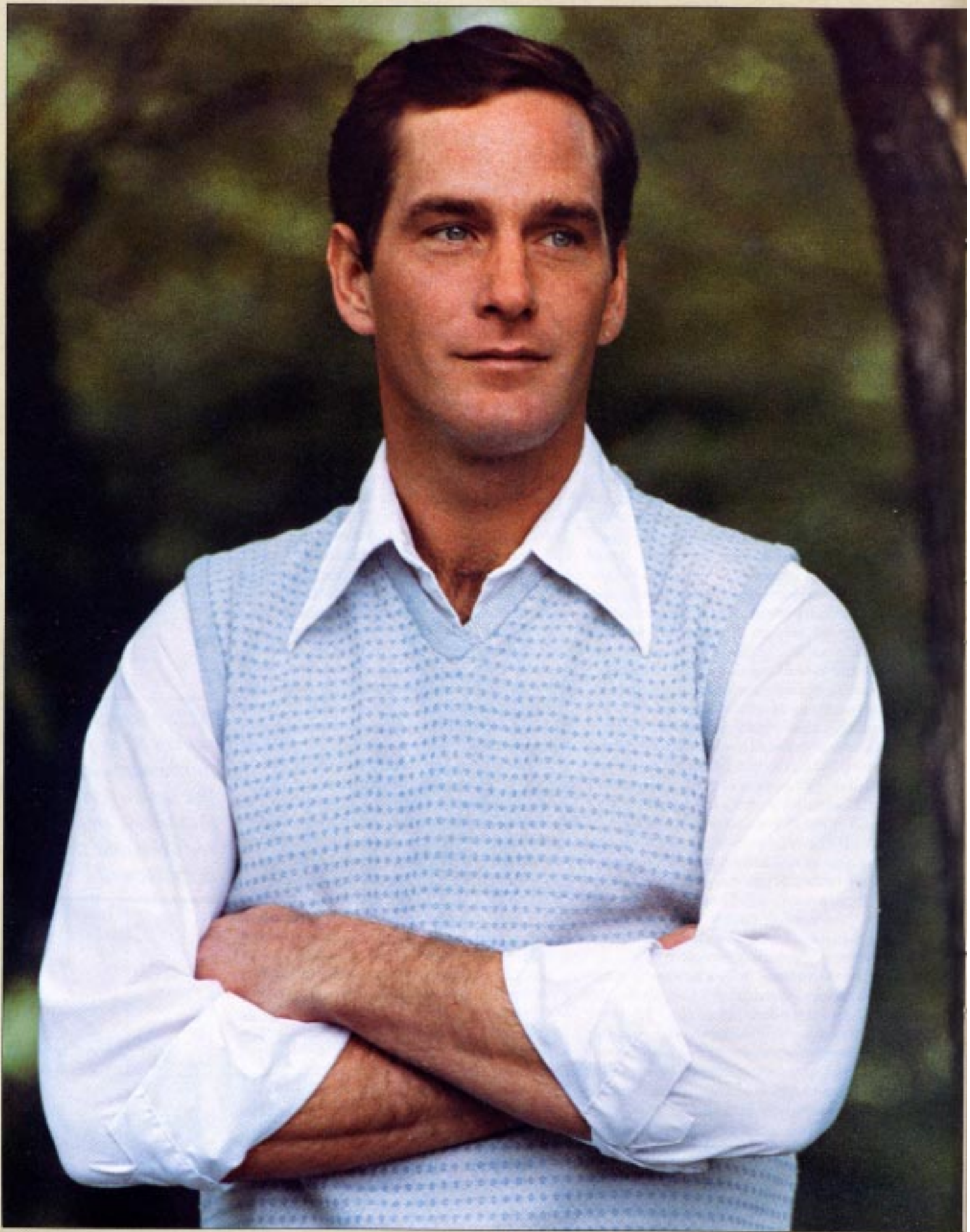

A Special Summer Vest

...
by Lucy Anne Jennings

FOR A BIT OF WARM SUN in the midst of winter, try this special summer vest. Made of lightweight cotton in pastels, it has a soft hand and is adaptable to many uses and individuals.

This vest was first designed with my father in mind. He has supplied my weaving needs with no less than three spinning wheels, a skein winder, a loom and many other pieces of equipment. Each one is a finely crafted work of art made especially by his hands. I wanted to thank him by weaving something special for him to wear that could be easily laundered and would require no ironing. I considered various hand-woven garment plans. Since my father lives in the southwestern desert area, I decided that a cool, breathable cotton vest would best fit his needs and personality. I had some light blue cotton on hand, and felt that it would go well with his clear blue eyes.

I had been sampling waffle weaves, as well as other patterns on a five-harness point twill threading. I decided to combine several of these patterns and textures in the project. The dotted swiss pattern that I chose for the front of the vest demanded quite a bit of patience in

the weaving. As I worked, I remembered that making those spinning wheels was no easy task either.

Waffle weave has an elastic effect, so I used it at the waistline for a mock ribbing. A plain tabby for the back contrasts with the pattern on the front.

To finish the garment, I wove some twill tape with the same yarns and used it to bind the neckline and the armholes.

Size: Men's 44" chest.

Warp: 10/2 unmercerized cotton,

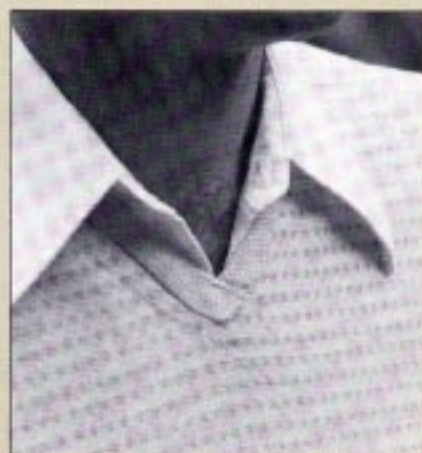

cream, purchased from Cotton Clouds.

Weft: 10/2 unmercerized cotton, light blue, from the same source.

Sett: 24 e.p.i, double-sleyed in 12 dent reed.

Width in reed: 27 inches.

Total Warp Ends: 648.

Pattern: Waffle Weave and Dotted Swiss from *New Key to Weaving* by Mary Black.

Weaving: Weave 32 inches for front, using treadling order B as shown in draft. Be sure to keep the beat even, to keep the pattern even.

After pattern area, weave 4 inches of waffle weave, then 1 inch of tabby for the bottom hem.

Weave in 4 picks of bright yarn to separate front and back. Weave back, beginning at bottom edge: 1 inch of tabby for hem, then 36 inches of tabby for body.

Finishing: Machine wash the fabric in hot water. Tumble dry. This will create maximum shrinkage, so the vest will be guaranteed easy care. The shrinkage for the tabby and dotted swiss portions of the vest fabric was approximately 20%. The waffle weave areas had a shrinkage of approximately 30%.

Assembly: Measure model for neck and armholes. Use dressmaker's chalk to draw cutting lines on the front neck. Using zig-zag stitch with a sewing machine, sew along chalk line, as well as bottom hems. Mark the armhole lengths, allowing 1/2 inch for shoulder seam. Place front and back pieces right sides together, and sew the side and shoulder seams. Hand-stitch the hems.

If desired, a twill tape may be woven to bind the armholes and neck. The tape I wove was 3 yards long, using

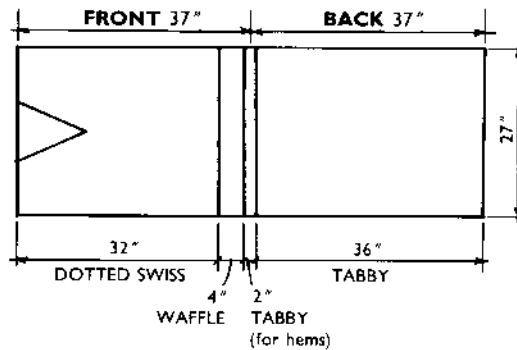

Pattern Layout

This is approximate. For neck and arm openings measure the wearer.

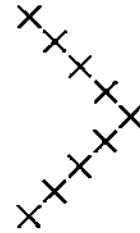

WAFFLE (no tabby)



DOTTED SWISS (use tabby for pattern. 8 picks tabby between each pattern repeat)



TABBY

the same warp and weft of the vest. Be sure to wash and dry the tape along with the vest. Hand-stitch the tape to the

neck and armholes. If no tape is desired, the neck and sleeve openings may be hemmed.

HERE...AT LAST...and a FIRST

A HAND WEAVING LOOM YOU CAN LEARN TO OPERATE IN MINUTES

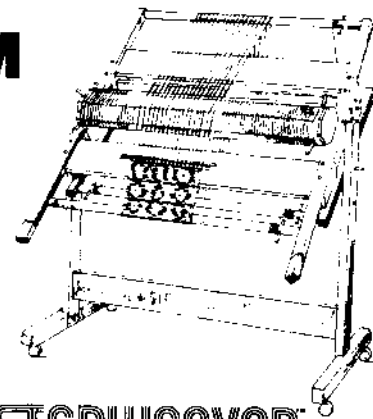

MASTERWEAVER

- INFINITE PATTERN POSSIBILITIES
- NO HEDDLES TO THREAD
- NO FOOT PEDALS

- COMPLETELY NOISELESS
- LIGHT & PORTABLE

Here indeed is a revolutionary new concept in weaving. Imagine a handweaving loom so simple to operate, in minutes you can turn out expert weaving.

The **MASTERWEAVER** is the most advanced handweaving loom on the market today. It is a new concept in loom technology, designed specifically for the purpose of fast and easy pattern weaving without the necessity for any additional

equipment. Conventional methods of warping and weaving are reduced here to a quick and simple process requiring no previous knowledge or experience in weaving. Any design which can be produced on a 24 harness traditional loom can be woven on the **MASTERWEAVER**.

There is no limit to the things you can make on your **MASTERWEAVER** - weave for fun and pleasure, for profit, or just save money making your own clothes.

EQUIVALENT TO A 24 HARNESS HANDLOOM

For our 50 page information booklet mail coupon to:

MASTERWEAVER (1982) LTD

3922 Chesswood Drive, Toronto, Ontario, Canada M3J 2W6 (416) 638-6370

Please rush me your 50 page booklet on the **MASTERWEAVER** multiharness handloom. I am enclosing \$2.00 to cover postage & handling.

Name _____

Address _____

City _____

State _____

Zip _____

MASTERWEAVER (1982) LTD.

3922 Chesswood Drive, Toronto, Ontario, Canada M3J 2W6

Symbolic or Sacred?

A personal view

by Diana Lockwood

THE RESURGENCE OF interest in a dynamic, contemporary, Christian art has created a wide open field for weavers who are endowed with faith, creativity, and technical skill. Many, however, who have the interest and the talent, have not felt comfortable working for the Church for fear of making an error in something that is "religious." Our boredom with the old brocade and gold embroidered paraments, with the symbolism that has come to us from England or Rome, which has little to do with our lives or the variety of cultures in North America, is wiped out by our fear of making waves. We are concerned that the members of our congregations might question the work that we are doing. We therefore send away to the religious supply houses for our liturgical needs, assuming that if it is sold by them, it will be



Chasuble of the Skies at Sunset. Painted warp, twill weave.



Detail, ikat stole
with blue and
purple represent-
ing the skies and
mountains of
Hawaii, and gold,
the Hawaiian
royalty.



correct. After all, we want to be traditional.

Weavers! Ordering from a catalog is not tradition. Tradition is created in your community, using materials at hand and symbolism having some meaning for your people, in order to enhance the worship experience. By making the assumption that a symbol that was appropriate 100 years ago is equally valid now, we are ignoring our special gifts as fiber artists. We could be creating something more meaningful and thought provoking for our congregation by working with them and learning what is unique about our special time in history, our community, and our people. Do not misunderstand me. I am not saying that tradition is in any way bad, I am trying to stimulate thought about what symbols are used in the church, whether they have meaning for you today, and whether they are as powerful as anything that could be created by you.

When a symbol becomes too familiar, it may lose its power to evoke thought and emotion. Not only are the traditional symbols showing up too frequently, they are being used in more places than necessary. One cross is a very powerful symbol with heavy emotional connotations. It should not be merely a decorative touch. Twenty crosses are not necessarily twenty times more powerful; the strength of the first may be diminished by the other nineteen. Since the altar itself is a symbol, weaving a loaf of bread and a chalice of wine into the frontal becomes redundant. Each vestment, by virtue of its shape and history is symbolic of certain aspects of Christianity. A stole is made no more valid by placing a "kissing cross" at the neckline. It is not necessary to copy a symbol just because that is what has been done before. We are a visually oriented society—television has become our major form of communication. We need to give a visual form to the Churches' justification for being.

For some reason, the idea of the vestments and paraments that we create to give glory to God, has sometimes become confused with Godliness. The objects are often confused with their purpose and people think of them as "holy." Objects can be touched by holiness, but they are not holy themselves. The people who wear the vestments and decorate the church with the paraments are dedicated to giving glory to God. Serving the church with love at the core of their ministry, they fill the place they work in and surround the garments they wear with love and holiness. Without these actions, the valuable objects of the church are just objects.

While I was conducting workshops in Samoa last year, some of the members of a

Samoa congregation indicated to me that they were ashamed that they could not worship “properly” as they did not have the “correct” equipment for the various liturgies. They had failed to realize that polished coconut cups in a tropical environment say as much as silver chalices in a magnificent British cathedral.

Color can be used as symbol. While certain colors are traditional in specific seasons, these color sequences are not carved in stone. They were set up by man, not by God. Just because the Sarum colors—red for Advent, white for Easter, for example—were adopted in the fourteenth century by the Cathedral Church in Salisbury, England, it is not necessary to feel that we are bound by them today. If your congregation is insistent on their use, by all means use them. If not, the color that is appropriate for what is being said, or for whatever feeling you are trying to portray in your worship, should be used. Combinations of color work also, and can sometimes make a more powerful statement than a single color would.

To give an example of what I mean, two years ago I was asked to weave a stole representative of the Diocese of Hawaii for presentation to the visiting Archbishop of Canterbury. A written description of the stole was given to the Archbishop and the following is a quote from it.

“The method used to make this hand-

woven silk stole is called ‘ikat.’ It is an ancient Asian and Indonesian technique of dyeing the warp threads prior to placing them on the loom, and in this context, it is used to represent the diverse cultures of Hawaii.

“Starting at the neck, each color has a specific meaning. The red and gold are the Hawaiian royal colors and honor Queen Emma and King Kamehameha IV. They asked Queen Victoria to send a Bishop of the Church of England to Hawaii, and donated the land upon which the Cathedral was built. The blue which is next, represents the Hawaiian skies. The purple is the mountains, the green, the valleys. The color of the beaches comes next, and then the waters as seen over

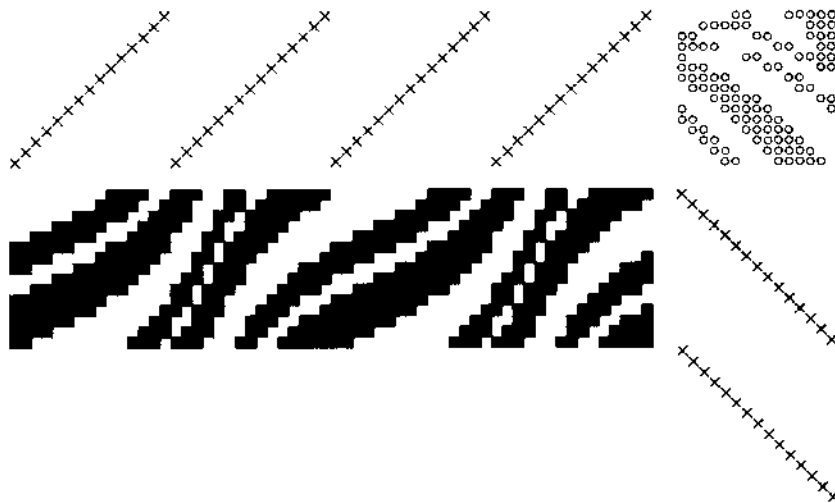

Chasuble of the Seas. Striped warp, undulating twill weave.



Chasuble of the Land. Ikat
warp, plain weave.



the coral reefs and at greater depths. The weft thread is blue, symbolizing the oceans which unite us all in our great island world. When taken all together, the stole represents a rainbow, a symbol of Hawaii and a symbol of God's promise."

We must free ourselves to create symbols that are appropriate and meaningful in our time and to our culture, and to use color in a way that does more than perpetuate tradition. With thought, an artist can effectively combine contemporary colors and symbols with traditional Christian doctrine, expanding the meaning of each. By creatively bringing the daily life of the community into the Church, the artist creates a new integrity of expression with a more relevant message for all.

When I was asked to make a set of vestments for the Episcopal Bishop of Hawaii, it seemed to me that these garments should represent Hawaii. What better symbol of Hawaii than the Maile Leaf lei? It would fit beautifully on the orphrey that goes up the front, across the back, and down the other side of the cope, following just the route of an open ended Maile lei. Furthermore, the Maile lei has great ceremonial, official, peace-making, and festive significance to the people of Hawaii. Surely the Bishop's visit to a congregation is a ceremonial, official, peace-making, and festive event. As a vine, the Maile is also

appropriate Biblically, bringing to mind John, Chapter 15, where Jesus says, "I am the vine, you are the branches. Whoever remains in me, and I in him, will bear much fruit; for you can do nothing without me."

The Maile vestments are woven in a tabby weave of natural Tussah silk. The orphrey on the cope and chasuble is a dyed raw silk, as is the mitre band and stole. For the Maile, I combined techniques, as I frequently do, and appliqued leaves made of Pongee silk and raw silk on to the bands by hand. Each leaf was stuffed to give it some depth, then embroidered with silk threads.

This set of vestments very clearly demonstrates my feeling that cultural symbols can be combined very effectively with traditional Christian symbolism to create a new integrity. This has more meaning to people of a given community or ethnic group than some of the worn out symbolic clichés.

Weave can also be used as symbol. In my liturgical work, I do this as often as the design permits. For example, one of the symbols for the season of Pentecost is the flame. It would be hard to find a better weave than the Flame-point on a Honeysuckle threading found in Mary Black's *A New Key to Weaving*. For Advent, the Christmas season, how about the Star of Bethlehem pattern from Marguerite Porter Davison's, *A Handweaver's Pattern*

Book? Green is the usual color used in Epiphany and the symbols of the season represent growth. One weave that would be very appropriate is the Maple Leaf Pattern, once again from Mary Black's book. Do not just use the patterns of other weavers however, feel free to create your own as well.

The "aina" or land and things natural are very important to the people of Hawaii. For this reason I designed a set of three chasubles representing the seas, the sky at sunset, and the land.

In the "Chasuble of the Skies at Sunset," an airbrush technique was used to dye the sunset into the silk threads of the warp. This created a modified ikat. The weft thread was a slubby rayon, space dyed in sunset colors. The twill weave used, radiating from the bottom center, represents the rays of the sun as it sinks into the sea. The colors go from yellow at the hem to a dusky purple at the shoulders. In Psalm 84, verse 11, God is likened to a sun and a shield.

A fifteen harness undulating twill represents the ocean in the "Chasuble of the Seas." Water, in Christianity, is the symbol of baptism and everlasting life. To the people of Hawaii, the sea provides life and unites them with the people of the rest of the world. The warp colors I chose were the different shades of blue that I see in the waters surrounding the Islands. The weft was a space dyed slubby rayon, also in the many colors of the ocean.

Weave as symbol is not always successful. I experienced this in the "Chasuble of the

Land." I dyed these warp threads in the ikat technique, choosing colors that ranged from the red earth of Moloka'i to the deep brown of the earth in the taro fields of Kauai. I had planned to use a weave that represented growing plants. However, I very quickly found that a tabby weave was far more appropriate. The combination of the pattern and an ikat made the pattern far too busy and each detracted from the other. The fibers used for both warp and weft were rayon.

While the examples that I have used here are representative of the cultures and symbols of Hawaii, the same basic principles of local reality within a spiritual context, can be applied wherever you live. The important thing to remember is not to let yourself become intimidated at the thought of taking on a project for the Church.

The spirit of liturgical renewal in Christian churches today offers real opportunity for the liturgical weaver. It also poses a challenge: the expansion of a routine that through formal tradition might have become dull and lifeless, into an experience that makes something happen inwardly. Liturgical weavers must search for every possible means of contributing to living worship. There is no single "correct" way to do this. Each artist must find his or her own way. The challenge of expressing the eternal nature of the spiritual truths of the Christian faith, using the temporal materials at our disposal, demands study, open-mindedness, and above all, fresh, individual inspiration.

Maile Lei Vestments designed for the Episcopal Bishop of Hawaii.



Maile Lei Vestments Set

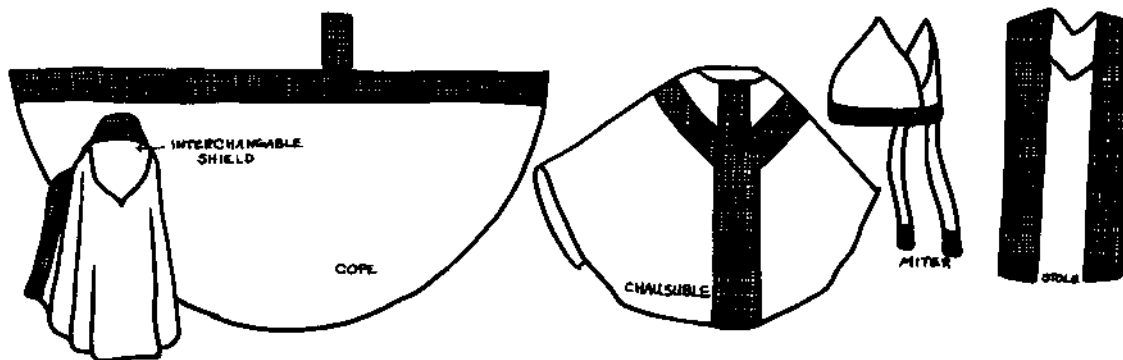

Vestments: Articles of clothing worn by the clergy and lay assistants during the services of the church.

Cope: The cope is derived from the Graeco-Roman paenula. It is a semi-circular piece with the straight edges brought to the center front and fastened at one point rather than sewn up as the chasuble is.

Orphrey: A decorative piece of fabric used on vestments.

Chasuble: A semi-circular wool garment, seamed in front and with a neck opening at the apex of the resulting cone; the garment of primary liturgical significance.

Mitre: A liturgical headdress worn by Roman Catholic and Anglican bishops as a distinctive mark, but also sometimes worn by abbots and other Roman Catholic clergy with permission of the Pope.

Stole: A narrow band of fabric worn by ordained clergy.

NOTES OF A PATTERN WEAVER

Tied Lithuanian

by Philis Alvic



Lincoln Park Conservatory by Philis Alvic.

HERE ARE MANY FACTORS that contribute to the process of making a weave structure part of one's creative catalog of working resources. Because I have gone through this evolution recently with Tied Lithuanian, I will use it as my example. My first introduction to Tied Lithuanian was through *Weave Structures Used in North American Coverlets* by Clarita Anderson, Judith Gordon, and Naomi Towner. In this book, which is a "poor weaver's" edition of an extensive portfolio with woven samples, there is a threading draft, a clear concise outline of characteristics and photographs of both the front and back of the sample for each of the weave structures identified. The material on Tied Lithuanian was new to me and I found it very exciting.

As a weaver with some experience under my belt, I figured there was ample information supplied to be able to weave something. For some time I had wanted to weave small scale pieces and this seemed an opportunity to combine the two projects. I had no difficulty in expanding the threading draft to use all of the 16 harnesses I have available on my loom. The threading of the blocks progressed in single units in consecutive order and then back again (A,B,C,D,E,F,G,F,E,D,C,B,A) to ensure that all designs woven would have the security of symmetry. Each block was threaded in a slightly different color green with the intent that the color change would help me keep track of the block placement. However, this also added nicely to the richness of the surface. I was so consumed with the symmetrical figures I could create that I wove close to 3 dozen small pieces.

Well, I had proven to myself that there was definite flexibility in design using this weave structure and I felt that I needed to explore further. Propelled on by my success, my next project in Tied Lithuanian varied the warp in random stripes not related to the block progression. This warp was also for small scale pieces and I kept the point block progression because I wanted to continue creating the varied figures. After a couple dozen of these small pieces I knew that Tied Lithuanian would continue to be a valuable tool and I wanted to investigate other aspects of it. The next project was also for miniatures with a random striped warp, but with the important innovation of the tie threads

in a contrasting color to the main body of the warp blocks. Since I felt that I had a grasp of what I was doing, I gave up my reliance on symmetrical figures and threaded in a single block progression.

By the end of this warp, I felt that I had to share my discoveries and delight in Tied Lithuanian with other weavers, so I wrote an article for the *The Complex Weaver*. This effort prompted a response from a Lithuanian weaver, Ada Petraitis. She produced some patterns from a long out-of-print Lithuanian book along with the information that this weave structure has long been

weavers, who knew of my growing interest in Tied Lithuanian, directed me to an exhibition of Lithuanian folk art that was connected with a summer festival. As a bit of providence, my annual dose of big city culture coincided with this exhibition at the University of Illinois, Chicago Circle campus. At this exhibition there were some beautiful examples of Tied Lithuanian even though most of the weaving used intricate overshot pick-up patterns—more typical of Lithuanian weaving. My enthusiasm for the pieces was apparent as I began asking questions of the exhibi-

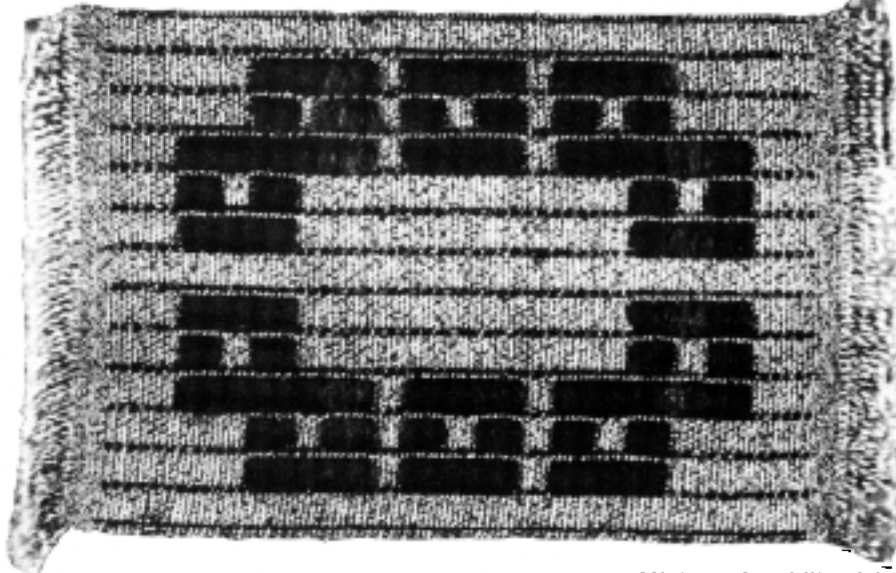

Miniature by Philis Alvic.

referred to as "Dimai." At this point, I realized that my knowledge of this weave structure was almost entirely from my own experiments and that I knew nothing of the historical tradition of Tied Lithuanian. I knew this was a very rare structure used in coverlets and that it originated in Lithuania, but really nothing else. I had not even seen an actual textile woven using Tied Lithuanian that I had not done myself.

I talked with Judith Gordon who thought that there might be a piece using this structure at a museum of Lithuanian culture in Chicago. She accompanied me there during a summer visit to the city, and we did discover a piece. But, we could not convince the caretaker to let us examine it more closely, so it remained to us a dimly lit corner of a coarsely woven coverlet. The museum sales counter did yield a book on Lithuanian costumes in which there were unmistakable examples of the use of the weave structure. My knowledge base was continuing to build when

tion receptionist. She directed me to one of the show organizers who happened to be preparing for an opening reception as part of the summer festival. With one of those "small world" coincidences, this person turned out to be the sister of the woman, who with her husband, had written the book on costumes that I had recently purchased. She was very generous in answering my inquiries even though I was interrupting the preparations. I left there feeling that I now had a much firmer grasp of the subject, but also with a clear knowledge that I had just begun to scratch the surface of what there was to know.

Tied Lithuanian, through a diverse set of experiences using it and in learning about its use, has firmly established itself as part of my working resources and the knowledge base will continue to expand. My technical understanding of it grows through diverse weaving projects and samples woven by participants in workshops that I have taught. Teaching forces me

to clarify aspects that I might not have gone into in such depth on my own. And, the experiences I have had so far lead me to believe that there is a lot to be learned from the way the Lithuanians produced and used fabrics woven in this structure. I do not intend to reproduce their work, but to learn more about the diversity and adaptability of the structure and to be stimulated by their designs.

The Weave Structure

I use different structures in my work because they look different and lend themselves to different design uses. Tied Lithuanian is a block weave structure with a very distinctive surface with large overshots that are caught at constant intervals by a tie thread. These weft overshoot areas tend to be viewed as strong vertical columns. The blocks that are created by raising warp threaded blocks (on a rising shed loom) appear as windows within the overshoot bands. The warp blocks are plain weave consisting of the interlacement of the warp with the tabby. Consecutively raised warp blocks have a vertical line, too, at the tie interval where the overshoot weft peeks through when the tie is activated on the underside of the fabric. The two sides of the textile created have exactly the same structure with a positive/negative reversibility. If a design is drawn by filling in squares on graph paper, the top side of the resulting fabric will have the darkened square design in plain weave blocks with the background the weft overshoot. The reversed side will present the design in overshoot with a plain weave background.

In Tied Lithuanian, two harnesses are required for the tie threads and two harnesses required for each block, so there must be a multi-harness loom available to produce anything. As with

any block weave the more harnesses the more blocks, and the more versatility in design. Threading units may be combined into larger blocks or taken as one unit per block. There is no restriction on block progression in threading and therefore, they may be in any order. I have given here an 8 thread block size, because that is what I was originally introduced to and have accumulated experience using. But the size could be 4, 6, 10, or 12 threads either contracting or extending the length of the overshoot.

The treadling progresses in similar fashion to most block weaves: a pattern shot followed by tabby. The weft overshoot is usually a heavier yarn than the warp and, a contrasting color to the warp, if strong design delineation is desired. The tabby is most often the same weight and color range as the warp to produce a balanced plain weave in the warp block areas. When treadling the warp block or blocks in a design the same tie thread is always activated. This tie thread is caught by the odd tabby which is every fourth shot: overshoot weft, even tabby, overshoot weft, odd tabby that anchors tie thread. The other of the two tie threads functions on the reverse side of the fabric. The treadling is not as difficult as might be expected because the tabby treadles are the same weight. The only difficulty arises when a design requires 5 or more blocks to be activated at the same time. Usually this can be avoided by reversing the positive and negative of the design. Always select the side of the fabric as the surface for weaving that requires the least number of harnesses to be raised. This makes absolutely no difference in the finished product, since both sides are structurally the same, and the resulting fabric can easily be turned over and designated as the "right" side.

The design possibilities are limited only by the size of the loom available

which prescribes the number of blocks possible. To determine the number of blocks possible on a loom, take the number of harnesses, subtract two and then divide this number by two. (There is an alternate threading for 8-harness that allows 4 block designs, but there isn't space to include explanation of it within this article.) Designs are worked out in a positive/negative format on graph paper keeping in mind the restriction on the number of blocks. I have found that I often turn designs into figure/ground studies similar to those I did many years ago as an art student. In this way of working, the positive and negative parts of the design are about equally balanced and inter-related so the viewer has trouble deciding which part is the figure and which the background. This worked particularly well for the miniatures that were displayed in stand-up plastic frames with both surfaces visible. The design flexibility also permits strong figure delineation as in "Lincoln Park Conservatory." In this piece the blocks were threaded in even single units to be able to combine them into a variety of different flower figures during the weaving. I have really not done much work with combining units in a threading block or with having threaded blocks of different sizes. Both of these areas suggest many possibilities for design. From the little bit of research that I have done, I know that many of the Lithuanian textiles in Tied Lithuanian employ the combined unit block and these will act as a guide for further exploring.

Bibliography

- Alvic, Philis, "Tied Lithuanian." *The Complex Weaver*. Vol. III #3, April 1982.
- Anderson, Clarita, Judith Gordon and Naomi Whiting Towner. *Weave Structures Used in North American Coverlets*. Self-published book, Mt. Olney, MD, 1982.
- Burnham, Harold B. and Dorothy K. Burnham. *Keep Me Warm One Night: Early Handweaving in Eastern Canada*. Toronto: University of Toronto Press, 1972.
- Petraitis, Ada. "Dimai Patterns." *The Complex Weaver*. Vol. IV #2, January 1983.
- Petraitis, Ada. "Dimai." *The Complex Weaver*. Vol. V #3, May 1984.
- Tamosaitis, Antanas, and Anastasia Tamosaitis. *Lithuanian National Costume*. Lithuanian Folk Art Institutes, Toronto, Canada, 1979.

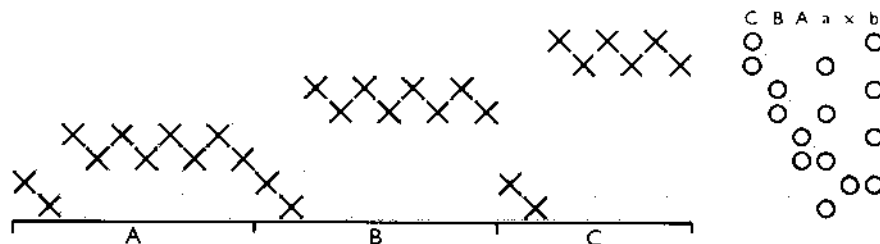

Cut & Sew Mittens

by *Nina Winchester*

IF YOU ENJOY being outdoors during the winter months, as I do, you will want to make yourself a pair of these mittens. The one-piece pattern is cut from a handwoven or felted fabric, sewn together and finished with either a few rows of crochet or a knitted ribbed band.

Suggested fabrics are as endless as the weaver's imagination. Handspun yarns make lovely textured mittens. A finer wool woven into colorful bands of Monk's Belt or Rosepath also works well. Areas of angora stripes would make an interesting effect as would novelty yarns.

Personalize your finished mittens with the addition of a braid trim or sew a piece of suede to the palm. A tassel hanging from the crocheted band at the wrist is another interesting touch. Whatever you choose to do, have some fun creating them and wearing them.

Mitten Construction

1. Pin pattern to fabric and baste the outline of the pattern onto the fabric. Remove the pattern and using a short machine stitch, stay-

stitch along the basting line. Make another row of stitching just inside the first row of stitching. Cut out mitten $\frac{1}{4}$ " beyond the stitching. Repeat for second mitten. If your fabric has a right and wrong side, be sure to place the pattern correctly.

2. With the right side up, fold "A" to "B" and pin in place. Sew along inner line of stay-stitching, leaving the lower edge open.

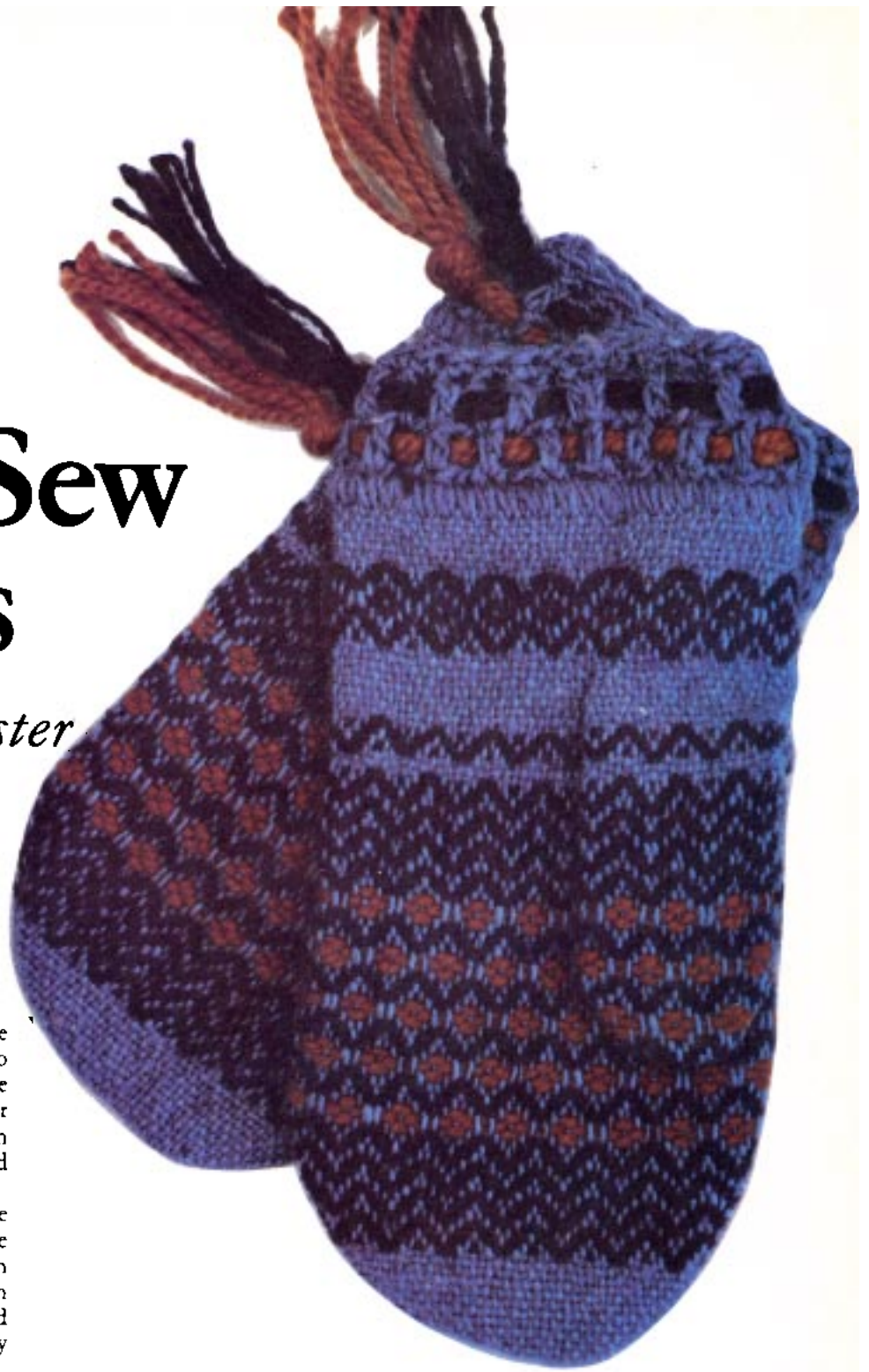
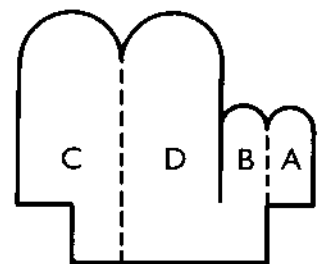

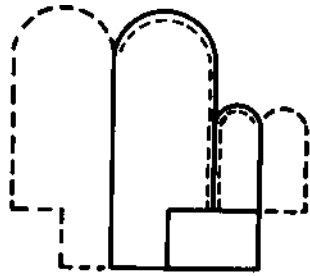

3. Fold "C" to "D" and pin in place. Sew along inner line of stay-stitching, leaving the lower edge open as shown. If your fabric tends to ravel you may want to zig-zag the edges you just sewed.

4. Turn palm and thumb section right sides out and press seams. Your mitten should look like this:

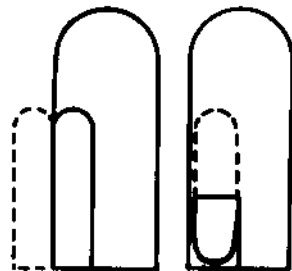

5. Now, fold thumb over onto palm and fold thumb down to expose the open seam. Turn the raw edges to the inside and stitch the seams closed by hand sewing. Turn in raw edges on remaining edge and continue to sew the seam closed.

1 SQUARE = 1"

Materials used for mittens pictured:
 Warp: Harrisville singles
 Weft: Harrisville Homespun Tweed, Fort Crailo Rug Yarn
 Sett: 12. e.p.i.
 Pattern: Davidson's Swedish Rosepath No. XI
 Finishing: Full material in washing machine, gentle cycle for 4 minutes. Crochet an edging on wrist edge.

6. To finish the wrist edge, add either a crocheted band or knit a ribbed band.

Handweaving With Robert and Roberta A TRULY EXCELLENT HOME STUDY PROGRAM

STARTING WITH VOLUME ONE, THE FOUNDATION SERIES OF ASSIGNMENTS INCLUDING EQUIPMENT, DESIGNING, FIBER, COLOR, DRAFTING & BUSINESS **PLUS** ESPECIALLY PLANNED **WEAVING PROJECTS** TO BUILD YOUR FUNDAMENTAL WEAVING KNOWLEDGE AND SKILLS.

VOLUME TWO, THREE & FOUR CONTINUE STEP BY STEP TO HELP YOU PROGRESS FAR BEYOND THE MANY WEAVERS WHO HAVE FLOUNDERED YEAR AFTER YEAR.

WRITE FOR FREE DETAILS INCLUDING AN INDEX TO
 AYOTTES' DESIGNERY, DEPT. WJ, CENTER SANDWICH, N.H. 03227



ORDER ALL YOUR WEAVING, SPINNING, DYEING BOOKS AT DISCOUNT

Any good, standard Classics and many New Titles
 Also Needlework, Hobbies, Crafts, Dolls, Miniatures
 10% discount on any U.S. books

Please send SASE with your inquiry.

KATHERINE RAMUS

2100 E. EASTMAN AVE.,

ENGLEWOOD, CO 80110



**TWILLS and
TWILL DERIVATIVES**
Lucille Landis (2nd printing)

No need to depend on recipes for your twills! Use a logical approach to understand their construction, then design **YOUR OWN** four to eight harness fancy, braided, interlocking, corkscrew, decorated, and waving twills, or crepes, waffles, and shadow weaves.

150 B&W photos, nearly 300 patterns, 120 pages, soft cover, \$10.50. Add 7½% Sales Tax in Conn. Postage \$1.50 per copy, \$.35 add. copy. Dealer inquiries invited.

BOOK BARN
Box 256-J, Avon, CT 06001



Santa Fe Weaver's School

BOX 9001
SANTA FE, N.M. 87505
505-983-8058
SARA GILSTRAP
OWNER/DIRECTOR

WEAVING
INSTRUCTION

BEGINNING
INTERMEDIATE
ADVANCED
SPECIAL
TECHNIQUE

4 to 8 HARNES
FLOOR LOOMS
FURNISHED

WRITE FOR
BROCHURE
SUMMER CLASSES

Two Blade Drawing-in Hook
CUTS THREADING TIME IN HALF

Also
Automatic Denter
Acrylic Warping Paddle
Other Fine Tools

Send for Free Brochure

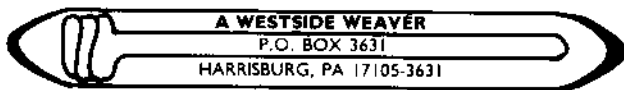

One week workshops for students of all ability levels and media interests.

MARCH 4-29, 1985

FIBER/FABRIC (JOHN MCQUEEN, KARI LONNING, NICOLE MILLS, NANCY SHAW CRAMER, ANITA MAYER, KATHY JAMES, VERONICA FITZGERALD, MIA KODANI)

CLAY (electric kiln - gas - raku firing, stoneware - porcelain, wheel - hand - building)/METAL (fabrication, enameling, blacksmithing)/STAINED GLASS/ WOOD (construction, turning)/ PHOTOGRAPHY

graduate/undergraduate credit
assistantships/scholarships
summer one and two week sessions June 3 - August 16, 1985
year round gallery exhibition schedule

ARROWMONT
School of Arts and Crafts
Box 567, Gallatinburg, TN 37738 (615) 436-5860

VÄV

MAGASINET

Scandinavian Weaving Magazine

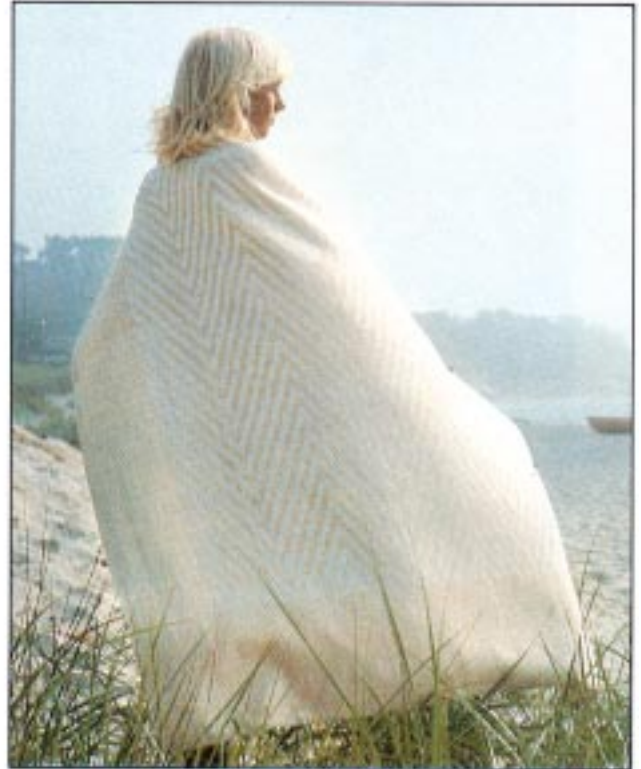

VävMagasinet comes out in four, colorful and inspiring issues per year (February, April, August and November). Each issue contains weaving projects designed especially for Scandinavian Weaving Magazine. We offer exciting reading about textile art and weaving, feature courses and exhibitions, and visit individual textile artists, industries, and weaving studios.

Scandinavian Weaving Magazine

is the magazine with the beautiful color photographs.

A one year subscription, now with complete English translation, costs \$22.00, airmail postage included. Please make all checks and postal money orders payable in U.S. funds to:

Stacey Jones Engel
Scandinavian Weaving Magazine
4909 Worthington Way
Ellicott City, Maryland 21043 USA

Dealers are wanted for Scandinavian Weaving Magazine in the United States.

JOIN US - SUBSCRIBE TODAY!

A Tailored Vest & Skirt

by Ruth Arnold

Vest and Skirt

Directions are given here for an easy-fitting ensemble of softly draped and pleated fabrics woven in a crepe weave to highlight the handwoven textures.

Commercial patterns have been adapted as noted. *Stitch* means machine stitch. *Stay-stitch* means stitch with the fabric grain. *Press* indicates use of steam iron with lift and press motion, not a sliding motion; use heat setting appropriate for the fabric and lining; use a press cloth. Follow general pattern instructions with changes as noted.

Vest

Loose-fitting vest with shawl collar, cap sleeve and back pleat from Butterick, pattern #6253 with adaptations as noted. For sizes 6-16.

Handwoven fabric, Crepe Weave Structure 1 1/2 yards (58") x 39" (washed & finished size).

Wilde Yarns 2-ply Clothing Yarn, 1440 yards per pound on 8 oz. cones.

Warp: Persimmon, Clove, Elderberry, Raisin.

Quantity: 410 yards of each color/4 1/2 oz. each color

Total yards = 1,640 yards

Weft: Raisin. **Quantity:** 760 yards/8 1/2 oz.

Warp Length: 3 yards, includes 1 1/2 (58") finished length + 10% weaving take-up + 10% washing shrinkage + 12" for sampling + 24" loom waste

Sett: 12 c.p.i.

Reed: 12 dent, single sley

Loom width: 45" (vest could be woven on 24" loom with width in reed 22 1/2", 270 ends, 5 yard length, 1,350 yards total. Skirt requires 45" width unless seams are added at center front and center back)

Loom: 4 or 8 shaft

Width in reed: 45"

Total no. warp ends: 540 ends

Weft picks per inch: 8 p.p.i.

Supplies: yarn for warp and weft, Butterick pattern #6253, sewing thread, yarn needle, weft yarn for overcasting seams

Winding the warp: 135 ends of each of 4 colors; total of 540 ends to be threaded randomly; avoid placing 2 identical colors next to each other in threading sequence. (Suggestion: wind the 4 colors together)

Fabric finishing: machine zig-zag both ends of yardage; machine wash in warm water with liquid soap/detergent on very gentle cycle; omit extraction cycles; hang fabric over rod to drip dry. (Suggestion: use sample section of warp to determine best washing procedure before washing entire yardage)

Pattern adaptations

- Unlined
- cut single layer collar and omit piece #16
- cut 1" seam at neck edge piece #14
- seams: modified welt and handstitching overcast with weft yarn



8-Harness: Straight Draw/ Standard Tie-up

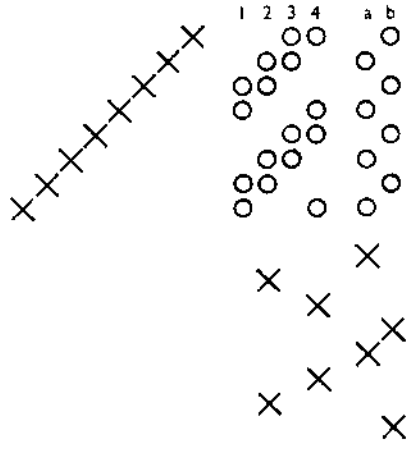

Alternate Tie-up

"Treadled-as-Walked"

1 3 5 7 8 6 4 2

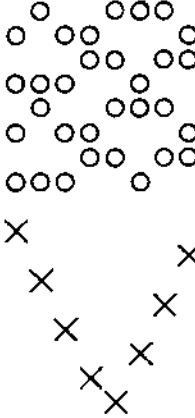

4-Harness:
Straight Draw

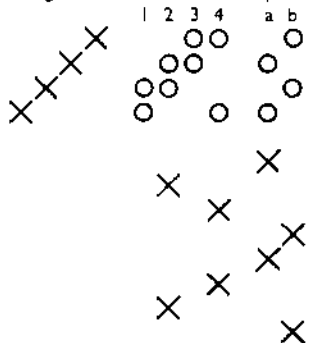

• edges: for collar, front and sleeve, fold under on seam line and overcast with weft yarn

• cut pleat underlay piece #15 with added extension above the pattern upper cutting line to allow pleat underlay to extend to back neckline deriving shape from *back* piece #14 (this will allow the unlined vest to appear more finished).

Lay out pattern with changes as above; cut; do not cut notches.

Mark dots, notches, roll line with tailor tacks using different colors for each kind of marking.

Zig-zag around all pieces following grainlines as for stay-stitching.

Lightly press all pieces on reverse side; use steam; use press cloth.

Follow pattern directions making the following changes:

Reinforce inner corner of front with machine stitching, pivoting at small dot.

Stitch collar section together at center back having *wrong* sides together and sew the 1" seam.

Center back seam: pin 2 back pieces right sides together, sew seam above large dot; below large dot hand baste; open center back extension; press seam on stitching line above large dot; on basting line only press lightly to establish pleat.

Stitch the *pleat underlay* and added extension piece #15 to back pleat extension; stitch both sides from lower edge up to neck edge; stitch from small dot to large dot at center back on each side; stitch through pleat underlay and back extension, keeping back of vest free.

Stay-stitch through all layers at back neckline.

Pin front to back at shoulder and continue pinning collar to back edge.

To stitch: 1) stitch from dot to center back from each direction; back neck edge is 1" seam; 2) stitch from dot out to edge of sleeve on each side; beginning at dot, ease and manipulate the fabric to work in smoothly; the flexible nature of this fabric allows the possibility of not clipping this front to the dot as indicated in the pattern.

Press open.

To finish neck and shoulder seam as a modified welt seam: 1) the back shoulder seam and back neck edge will be trimmed to ¼-¾"; straight-stitch through these back piece seam allowances close to the seam line; then trim and grade where possible; 2) the seam allowance of the front shoulder and collar will be pinned over the trimmed allowance and overcast in place.

To finish sleeve edges: 1) turn back on

seam allowance press; 2) overcast in place after stitching side seams.

Pin front to back at side seams; stitch; at ⅝" from top of seam at underarm, stitch at diagonal to outer corner to allow ease of turn back for sleeve edge. Press seams open. Overcast side seams and sleeve edges in place.

Hem: Turn up 1"; hand baste close to edge; press. 1) At *center fronts* the hem turn-up needs to change direction; again the flexibility of the fabric allows for accommodating this; pin, baste, steam and ease the hem to change at the center front roll line 2) At *back pleat* clip as shown in the pattern direction above the hem; below the clip, press the seam open and grade; above the clip, trim seam at a diagonal; zig-zag above and below clip.

Overcast hem in place.
Overcast edges of pleat underlay leaving free of vest back.

Steam press to define back pleat especially at hem line.

Steam press to establish front and collar roll line; use railors ham and rolled terry towels to create soft roll line.

Skirt

Softly pleated skirt with double front closure that allows for easy accommodation to range of waist sizes, 2 side pockets, lined; from McCalls pattern #7910 with adaptations as noted, sizes 6-14.

Handwoven fabric, Crepe Weave Structure, 2¼ yards (81") × 39" (washed & finished size).

Wilde Yarn, 2-ply Clothing Yarn, 1440 yards per pound on 8 oz. cones.

Warp: Raisin, quantity 2,025 yards/22½ oz.

Weft: Raisin, quantity 1,060 yards/14 oz.

Warp length = 3¾ yards, includes 2¼ yards (81") finished length + 10% weaving take-up + 10% washing shrinkage + 12" for sampling + 24" loom waste

Sett: 12 e.p.i.

Reed: 12 dent, single sley

Loom width: 45"

Loom: 4 or 8 shaft

Width in reed: 45"

Total no. of warp ends: 540 ends

Weft picks per inch: 10 p.p.i.

Supplies: yarn for warp and weft; McCalls pattern #7910, sewing thread, 2¼ yards lining (Ambiance Bemberg Rayon by Logantex), 4 yards seam tape, 2 sets hook fasteners, skirt waistband interfacing ("Waist Shaper" by Stacey) approx. 1 yard fusible, 1¼" wide.

Weave draft: threading, tie-up, treadling same as for vest

Fabric finishing: same as for vest fabric

Pattern alterations:

- This pattern needs to be altered to accommodate the 39" finished fabric width. Reduce width of pattern by taking a 3" tuck (6" total) in both front and back skirt pieces to match skirt width to fabric width.
- Redraw the tucks maintaining the same total waist measurement. Suggested tuck measurements from center folds: 3 1/4" tuck, 1 3/4" space, 3 1/4" tuck, 1 3/4" space, 3 1/4" tuck
- Waistband: alter so that the right side fastens like the left side. The front waistband will be a separate piece; piece to measure 1/2 the waistband length + 1 1/4" for seams. Back waistband to measure 1/2 the waistband + 6"—there are 3" underlap extensions on each side.
- Reverse the grainline indications on the waistband pieces; pieces will be cut across the grain.
- Instead of cutting full pocket pieces, cut 2 pocket lining pieces about 3" wide measured from the notched edge of the pocket and 11" long, rounding the inner/lower edge.

Lay out pattern with changes as above; cut; do not cut notches.

Mark dots, notches, tucks with tailors tacks.

Zig-zag stitch around all edges following grainline directions.

Steam press firmly all pieces on reverse side.

Pin in tucks front and back; machine baste at 1/2" from upper edges; hand baste tucks 1/2" below machine basting.

Press in pleats; use wet press cloth and wood pounding block; place light weight cardboard under each pleat while pressing to prevent ridges.

Lining: cut lining as for skirt front and back; cut 4 full pocket pieces; mark tucks, dots, notches conventionally.

Make pleats in front and back lining pieces as for skirt; pin pleats; make the outer pleats on the back section 1" smaller—the excess width will later overlap a seam. Stitch pleats.

Pockets: lay the 3" x 11" pocket lining (handwoven fabric) onto the full pocket lining piece; machine stitch close to all edges; make one each for left and right sides.

Sew lined back pockets to skirt back with right sides together; make one for left and right sides.

Sew skirt front to front pocket lining pieces with right sides together; press seam toward pocket.

Stitch skirt front to skirt back as pattern illustrates for left side and repeat this proce-

cedure also for the right side.

Finish the unstitched upper pocket edges by turning under a narrow hem twice and edge-stitching. Finish lower stitched pocket edges with zig-zag or narrow hem.

Press side seams open; do not clip seam as shown—instead press and ease in the seam direction change.

Press skirt front above pocket openings on a straight line between the dots.

Lining: join front to back; stitch from lower edge to 2" above side notch. To finish unseamed edges above notch, turn under a narrow hem twice and edge-stitch. Zig-zag side seams.

Pin lining to skirt with wrong sides together. Outer edge of back lining will overlap the pressed open back/pocket seam. Stitch at upper edges. Pin front pocket lining on top of front lining; stitch.

Waistband: interface with "Waist Shaper" using only a 1 1/4" wide strip. Cut 2 pieces; front waistband interfacing should be one-half the waist measurement (interfacing will not extend into seams); back waistband interfacing should be the remaining one-half of waist measurement plus 3" for both left and right side underlap extensions.

Apply interfacing to the unnotched edge which will be the inner side of the waistband. Apply as package directs.

Pin waistbands to front and back matching notches. Stitch. Press. Grade seam to reduce bulk (stitch through pleats and lining only, 1/4" from waist band seam and then trim and grade).

Turn waistband to inside; pin; tuck in ends of front band to be as trim as possible; do not tuck in ends of the back band; baste by hand; stitch by using "stitch-in-the-ditch" technique so that the line of stitching on right side falls between skirt and front waistband while sewing through the reverse side of the band.

Secure the "tucked in" ends of front band with hand stitching.

The unfinished inside edges of the waistband may be covered with seam tape applied by hand.

Sew hook and eye fasteners to waistband.

Hem: turn up skirt hem; hand baste close to lower edge; press lightly; apply seam tape to hem edge; hem by hand.

Lining hem: lining is to be 1" shorter than skirt edge; straight-stitch along lower edge; make a second stitching line 1/2" from first; turn under and press on second line; turn up hem and hand hem.

Skirt McCalls #7910

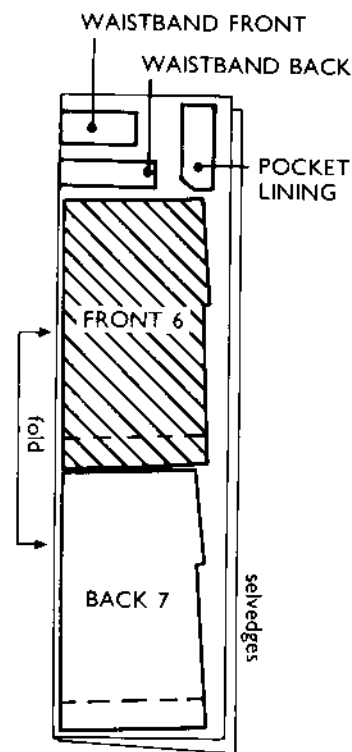

Vest Butterick #6253

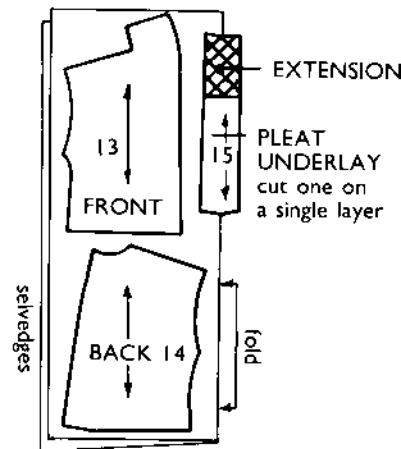



Beka Looms

Looking for a loom for yourself . . .



Finally, everything you've wanted—in one loom!

- Eight harnesses
- Up to 60" wide
- Easy treadling
- Fast tie-ups
- Loaded with features
- Cherry or maple

or for a friend?

Beka's got it!

- Rigid heddle versatility
- Up to 44" wide
- Three heddles standard (8, 10, and 12 dent)
- complete accessory package
- cherry



For further information write:

Beka, Inc. 1648 Grand Avenue St. Paul, MN, 55105 (612) 222-7005

Man-made Fibers

by Walter Hausner

NATURAL FIBERS have been grown and bred for millenia for their good all-around performance. Man-made fibers, by contrast, are specialty fibers. They are engineered for specific purposes and applications. They will perform superbly if used for the purpose for which they were designed, but will fail miserably if misused.

Man-made fibers are often described as *synthetics*. This term is not completely accurate, since synthetic is defined as a copy of something that exists in nature, and man-made fibers are not like anything that exists in nature. Some of the methods of preparing these fibers, such as crimping, or cutting into staple lengths for spinning, are attempts to give them some of the characteristics of natural fibers. Rayon is chemically the most similar to a natural fiber, but the relationship is generic: rayon is processed cellulose.

When we speak about textile fibers and their uses, we usually think about clothing, upholstery and decorative fabrics, wall hangings and wall coverings, household linens and towels, carpets and perhaps outdoor carpets, tents, etc. We might also consider tapestries and embroideries. But we tend to forget about a lot of other uses to which a substantial portion of the man-made fibers are put. Some very recent applications have been: contributions to fuel efficiency in cars, as essential components in spacecraft, protection of hunters and outdoor people from snakebite, saving lives in operating rooms, and as roofs over large areas such as sports stadia and airports.

One very important application of man-made fibers is their use in geophysics, as foundations of roadbeds and runways on swampy

or mud-bed land, lining of reservoirs, etc. And we must not forget industrial applications such as drive belts, industrial or automotive hoses, components of tires, filters, sacking and wrapping, and as filters in bag houses minimizing the emission of smokestacks. Hollow nylon fibers purify sea water to make it drinkable. Glass fibers carry telephone conversations or laser beams for non-cutting operations.

I have already mentioned the use of man-made fibers in operating rooms. An artificial kidney is made from hollow cupramonium fibers, artificial arteries and veins are made from polyester. Polyester is also essential in the construction of an artificial heart. I could probably list twice as many examples if space and time would permit.

How does all this concern the handweaver? Many of the latest applications for man-made fibers have been pioneered by handweavers. There is a vast field of study requiring experiment with fiber combinations, natural and man-made, or combinations of man-mades. It needs the skill and inventiveness of the handweaver to create new designs, constructions, and applications. It also needs the technologist to prescribe parameters and to test the results.

Today's living calls for easy-care fabrics, not only for apparel, but also in home furnishings. The textile mill can frequently supply the commodity but not the specialty; not the aesthetics that the individual wants. The handweaver can.

The easy-care does not apply only to apparel; it applies to household linens and dress accessories as well. The days of damask

Many of the latest applications for man-made fibers have been pioneered by handweavers.

Glossary

Bicomponent yarn. Consists of two types of the same fiber, in a sheath-core or side-by-side relation.

Biconstituent yarn. Consists of filaments composed of two different types of fibers in a homogeneous mixture. These are rare and have limited applications.

Cellulose. A carbohydrate which is the chief component of the cell walls of plants. It is a basic raw material in the manufacture of rayon, acetate and tri-acetate fibers.

Coning wax. A waxy emulsion applied to the yarn in coning to counteract the brittleness of the fibers and assist in fabric forming. It also reduces static and 'fly' from broken fibers.

Copolymer. A polymer composed of a combination of more than one monomer. Copolymers are the basis of some man-made fibers.

Cross dyeing. A method of dyeing blend or combination fabrics to two or more shades by the use of a single dye bath with dyes having different affinities for the different fibers.

table linen are gone. Washable placemats are the order of the day. I personally use saran and olefin fibers for these, but most polyesters would also be suitable.

Blends and combinations with natural fibers would also produce the easy-care characteristics, but this needs careful study and selection combined with experimenting and testing. A handweaver can do this much better than a large mill. As a matter of fact, many mills employ handweavers just for such research and development. The handweaver can do the job with a minimum of material and a fraction of the cost. The search for new fiber combinations and applications is endless.

I was a young man when the first rayons spun from rayon staple came on the market. They were used as and considered *ersatz* only, for the then unavailable natural fibers. I used them on their own merit, and this spun rayon staple eventually became popular and accepted in the marketplace for its desirable characteristics and not as a replacement, which it could never be. Some years later, when glass fibers were new and many mills had given up using them because uncontrollable yarn slippage was encountered, I succeeded in developing a construction that did not slip.

At about the same time, saran was made available, not only as monofilament fiber, but also as a multifilament, spun as straight yarn and as novelties. Saran's high specific gravity made the cloth produced from it heavy and expensive. It was a handweaver who combined multifilament and spun yarn into a viable construction.

Handweavers have frequently developed weaves and weave figures on multi-shaft looms that were so complicated that mills using them had to resort to using jacquard machines. It is a little known fact that many developments and applications of most new fibers and yarns were pioneered by handweavers, and that many new fashion trends were also developed by handweavers. But to do so, one must have knowledge of fibers and be willing to experiment to create something different and beautiful. There are a number of us who do just that, as a full time occupation, instead of endlessly duplicating one successful item.

Man-made fibers are available to handweavers as knitting yarns and mill ends. Nylon and rayon yarns are currently readily available. Many knitting acrylics or polyesters do not have good abrasion resistance for handweaving, thus their wearability is limited.

My recommendation to handweavers who want to use man-made fibers is to ask your supplier for what end use the yarn was

spun, or the type of product or market of the mill from which it came. This should tell the weaver the best use for the yarn.

The following is a brief listing of the development of man-made fibers that handweavers may encounter. New developments and discoveries are being made constantly, and by the time this is published, the list will already be dated.

The first recorded mention of the possibility of making artificial fibers that would imitate silk was by Dr. Robert Hooke in 1664. It was not until 1878 that Count Hilaire de Chardonnet started serious work on the problem, and obtained in 1884 a patent for a man-made fiber. This fiber, a nitrocellulose, was exhibited at the Paris Exhibition of 1889. A weak fiber, it was difficult to handle and slow to be accepted. An improvement, known as *Chardonnet artificial silk* was cupramonium rayon, a form of which later became known as *Bemberg rayon*, is still in production in Europe. Not until the viscose process was developed did artificial silk reach the mass market.

Viscose Rayon is produced as filament, staple and tow fiber. The fineness of an individual fiber can range from 1 to 15 or more denier. Viscose rayon is one of the easiest fibers to work with. It comes in an endless variety of sizes and forms, smooth or novelty. Rayon is easy to dye and process. Some forms of viscose rayon could shrink substantially in washing. However, there is a new form of rayon on the market, called High Wet Modulus Rayon. In this form, the viscose molecules are not single chains, but cross-linked chains, giving the fiber the same dimensional stability as cotton. Very good color fastness can be obtained with all rayons.

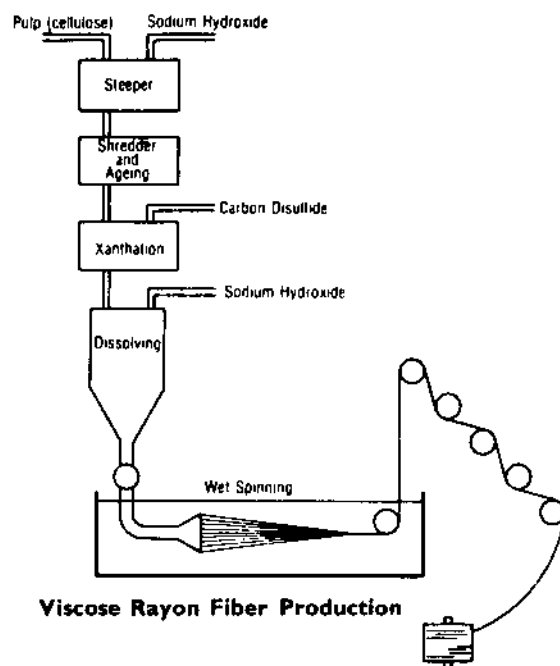

Viscose Rayon Fiber Production

Acetate was the next fiber to be developed. The first result of this research, Tri-Acetate, has considerable strength, but was at the time impossible to dye. An inferior form, Di-Acetate was developed which was relatively easy to dye, but its color range is limited, and the color fastness is not very good. The di-acetate fiber is also subject to gas fading, which changes the appearance of the colors.

A few years ago it became possible to dye and finish tri-acetate. Its strength and abrasion resistance is much better than that of di-acetate, but a steam and heat treatment is necessary to fully develop its qualities. This is known in the U.S. as *Arnel*. Acetate has an excellent drape and hand. It is often used in conjunction with cotton or wool to achieve cross-dye effects. Acetate is produced as filament, staple and tow. It is the first fiber which is a true plastic.

Another form of acetate was saponified into rayon filament, and is known as *Fortisan*. At present it is not produced in the U.S. Fortisan has a very fine fiber of .75 denier, and an outstanding wet strength. However, the diffraction of light from this fiber is such that even heavy dye concentrations result in pale pastels.

Nylon was a result of DuPont & Co.'s research into long chain polymers. It was introduced in 1938, and its manner of introduction was a classic example of how to ensure market acceptance of a new product. DuPont gave this fiber to only a few selected companies to try, and fully tested the product before allowing it to be marketed. This prevented misapplication in order to cash in on publicity, an action that has meant the demise of a number of promising fibers.

Nylon, (in Europe often called Perlon), is one of the strongest fibers yet produced, and it has exceptionally high abrasion resistance. However, this fiber has one characteristic that can be troublesome: relaxation shrinkage. That is, tension during processing stretches the yarn, which later relaxes and slowly creeps back to its original length, a process that can take a long time.

Nylon is a polyamide, and several forms are known. Type 6 and 6-6 are the most common. They are produced with both round and tri-lobal cross sections in various finenesses. The tri-lobal cross section variety gives a special crisp hand and a special luster to this product. Nylon easily accepts dye and can be stained by dyes that bleed from other fibers. Such stains are almost impossible to remove. The fiber is available as filament, staple and tow. The best known uses for nylon are in hosiery, lingerie, carpets and upholstery. Nylon fabrics can be treated to pass certain

flammability tests, but the fiber is never flameproof or even flame retardant.

After the development of nylon, an abundance of new fibers were rapidly developed.

Acrylic fibers are those containing at least 85% acrylonitrile. They are produced only as staple and tow, as fabrics made from the filament cannot be piece dyed. Various types of acrylics are on the market, imitating and often blended with wool, mohair, and angora. Fabrics made from this fiber or of blends with natural fibers show good crease retention and wrinkle resistance, but often have poor resistance to pilling. Extremely bright colors can be obtained by dyeing acrylics. However, flame retardancy and flame resistance treatment is very complicated and difficult.

Polyester is probably the most widely used and best known of all the man-made fibers. It is a long-chain polymer of an ester of dihydric alcohol and terephthalic acid. The variants of polyester are innumerable. One producer alone lists almost 70 distinct types. Polyester cross sections can be round, trilobal, pentelobal, octalobal and irregular. Polyesters are made as filament, staple and tow. A not inconsiderable portion of filament yarn is used in false-twist or friction-textured form (a method of producing texture by twisting, heat-setting and untwisting). The staple

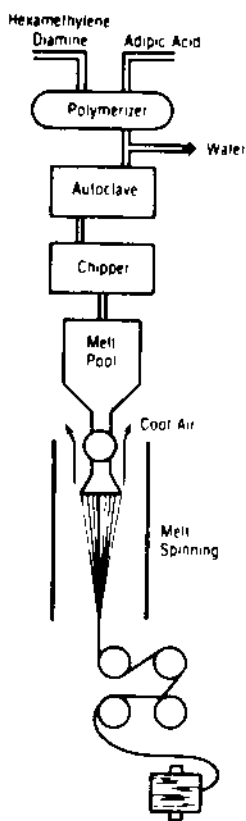

Nylon 66 Fiber Production



Cross sections

Cross Section. The shape of an individual filament when cut at a right angle to its axis. Normal shapes for man-made fibers vary, eg. round (nylon, polyester, polypropylene, some acrylics), serrated (viscose rayon, acetate and tri-acetate), bean-shaped (some acrylics and modacrylics). The shapes of man-made fibers may be modified by changing the shape of the holes in the spinneret. Cross-sectional variants are produced intentionally in a wide variety of shapes for different physical effects such as change in luster or hand, improved resistance to soiling, etc. Examples are trilobal (T- or Y-shaped) and other multilobal shapes (K, X, pentelobal, star, etc.), ribbon, square, triangular, elliptical, hollow, and many others.

Denier. A weight-per unit measurement used in the U.S. for numbering filament yarns, man-made fiber staple and tow. Officially, it is the number of unit weights of 0.05 grams per 450 meter length. Denier is a direct numbering system in which the lower numbers represent the finer sizes and the higher numbers the coarser sizes.

and tow fibers are specialized for spinning on specific spinning systems, for blending with specific fibers, for weaving or knitting, etc. The tendency now is toward more and more specialized types of fiber and to finer filaments. A 1.1 denier filament is on the market, and a fiber as fine as .8 denier has been reported.

Olefin: Polyethylene and Polypropylene, sometimes called "poor man's nylon" is characterized by low specific gravity and high bulk. There is only one dyeable type available, the color range is limited, and it is expensive. It is produced as filament, staple, tow, and bulked continuous filament. It has high abrasion resistance similar to nylon, but no relaxation shrinkage. Its resistance to damage by ultra-violet light is poor in some types. The olefins are relatively inexpensive.

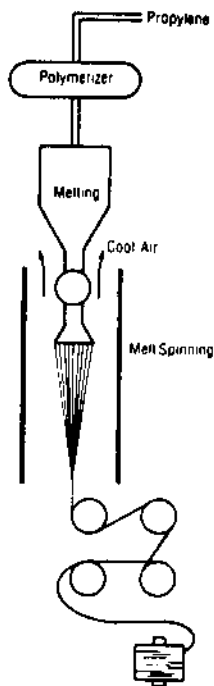

Polpropylene Fiber Production

Aramid is a long chain polyamide with its linkages attached to two aromatic links. Its outstanding properties are high heat resistance and flame resistance. The fiber is expensive and difficult to obtain. Its principal use is in protective clothing.

Elastometric: Rubber and Spandex are highly elastic monofilament fibers that can be repeatedly stretched and will fully recover. They are usually available in covered form, that is, an elastometric core surrounded by a spiral of spun yarn. Principal uses are in undergarments, bathing suits, hose and webbing.

Fluorocarbon is an absolutely inert fiber of low density and minimal friction, and is usable over an extremely wide temperature range. It is used mostly industrially, medically, and in protective clothing. This fiber does not accept dye.

Glass fiber is made from molten glass. It does not stretch, shrink or burn. The tensile strength of glass fiber is greater than that of steel. It is non-elastic and its abrasion resistance is poor. It cannot be dyed. Fabrics made from glass must be *coronized*, that is, heat treated and covered with a fine coat of plastic which can then be dyed or printed. Fabrics of glass cannot contain any other fibers because the high temperatures of the coronization process would destroy them. Glass is used in curtains and draperies and as a substrate for covered fabrics.

Metallic fibers are made from sheets of clear polyester film that are metallized under a vacuum and then slit into fine strips. If a heavy weight metallic is needed, a second sheet of polyester film is laminated over the metalised layer. Width of metallics ranges from $\frac{1}{125}$ to $\frac{1}{4}$ inch in normal usage. These fibers can be used by themselves or supported with one or more threads of silk or nylon. Metallics are also sometimes twisted into novelty yarns.

Modacrylic fibers are copolymers of acrylonitrile and either vinylchloride, vinylidene chloride or vinylidene dicyanide. These fibers are produced only as staple. Modacrylics

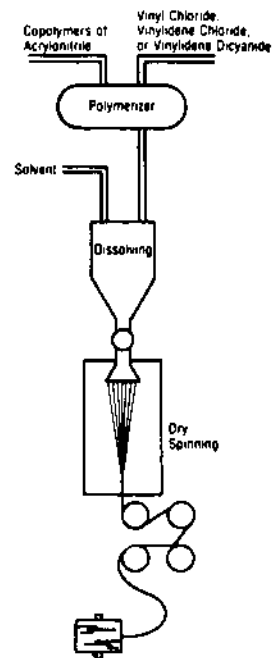

Modacrylic Fiber Production

Elastometric. Having properties of natural rubber, such as high stretchability and recovery.

Ester. A product formed by combining an acid and an alcohol.

Filament. A fiber of an indefinite or extreme length, such as found naturally in silk. Man-made fibers are extruded into filaments, which are converted into filament yarn, staple or tow.

Gas fading. The influence of atmospheric gas that discolors acetate fabrics. Actually, the fiber composition is changed, and not the coloring agent.

Monofilament. Any single filament of a man-made fiber, usually of a denier higher than 14, and strong enough to be used by itself.

Multifilament. A bundle of endless fibers forming a thread. The fibers have either a small amount of twist, or are slightly air-tangled. Most textile filament yarns are multifilament.

Polyamide. A synthetic polymer and the fibers made from it in which the simple chemical compounds used for its production are linked by amide linkages (-NH-CO-).

Polymer. A high molecular chain-like structure from which man-made fibers are derived; produced by linking together molecular units called monomers.

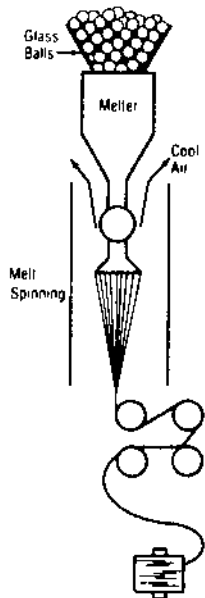

Glass Fiber Production

are inherently flame resistant and self extinguishing. Their main use is in drapery, children's sleepwear, fake furs, wigs and blankets. They are not used in upholstery, as abrasion resistance is insufficient.

Novoloid is a fiber formed from a highly cross-linked phenolic polymer which will not burn except in a high oxygen atmosphere, when it will carbonize. It generates only small amounts of smoke and noxious gas. It is used for fire resistant industrial safety clothing.

Reflective fiber is made from polyester, polyurethane and glass beads. The latter are incorporated as spherical lens elements to reflect light. These fibers are used in garments, pet collars and leashes.

Saran is made from vinylidene chloride. It is now made only as monofilament, and is self extinguishing when burned, but gives off toxic fumes. The yarn is heavy and has little bulk. Its main use is for garden furniture and automobiles.

Vinyon is a long-chain polymer consisting mainly of vinyl chloride. It has high resistance to chemicals and has a low melting point. It is used as a bonding agent, and in nonwoven specialties.

Flame Retardant Fibers. In addition to some already mentioned, there are flame retardant versions of rayons and polyesters. This characteristic has been achieved by the addition of certain chemicals to the spin solutions. The price of these specialty fibers is high, and the flame retardancy can be lost if traces of dye carriers, coning wax, etc. are not removed.

A new fiber, PBI-Polybenzimidazole, was recently introduced to replace asbestos.

Hollow Fibers of rayon and polyester were introduced relatively recently. The rayon fibers have an extremely high absorbency rate and their application falls into the surgical and hygienic field.

Over the years, many attempts have been made to produce protein fibers. To my knowledge, only *Smia Viscosas* "Lanital", made from casein was successful. It was used in combination with and in lieu of wool. It was not very durable and never was popular. Attempts were also made to develop fibers from soybeans and peanuts, but none reached the market.

Fabrics made from man-made fibers may be made of *bi-component* or *bi-constituent* yarns. Bi-component yarns consist of two types of fibers from the same fiber family, one of them usually a high shrinkage type, giving wool-like crimp and characteristics to the fabric after dyeing. Bi-constituent yarns are combinations of two different fibers such as polyamides and polyesters. A new bi-constituent yarn is just coming on the market, and will probably be publicized before long. Bi-constituent yarns are often used in pile fabrics.

All of the fibers listed except the rayons and acetates are *hydrophobic*. That is, they don't absorb water (moisture) and therefore frequently feel uncomfortable against the skin. Attempts to make fibers hydrophilic (water-absorbing) have generally not been successful. A moisture absorbent nylon was announced about fifteen years ago, but its price was so high that it found no market acceptance. Recently a polyester comfort fiber has been announced which is not hydrophilic, but has a kind of wicking action that can convey moisture away from the skin.

The non-absorbency of man-made fibers is responsible for the static electricity reaction of fabrics made wholly or predominantly from these fibers. The clinging of skirts and undergarments and the ever-dirty-looking edges and corners of carpets are manifestations of static.

The development of man-made fibers has run full cycle. Researchers began by trying to imitate silk, and now are trying to imitate silk again. *Qiana*, *Source*, *Golden Touch*, are some fibers that were specifically intended to imitate and replace silk. But silk has some characteristics that cannot be copied. We are coming close, but have not reached that goal—yet.

What is the future of man-made fibers? They are here to stay, and as the world's population grows and more agricultural land will be needed for food production, fewer natural



Spinneret

Spin solution. The heavy viscous solution from which fibers are formed by extrusion through a spinneret.

Staple. A fiber of limited length to be spun into thread (Natural fibers or cut lengths from filaments.) The staple length of natural fibers varies from less than 1 inch, as with some cotton fibers, to several feet for some hard fibers. Man-made staple fibers are cut to a definite length, from 8 inches down to about 1½ inches, so that they can be processed on cotton, woolen or worsted spinning systems. The term staple is used in the textile industry to distinguish natural or cut length man-made fibers from filament.

Tow. A large bundle of endless fibers in heavy concentration (many thousands of filaments) without definite twist, usually held together by crimp. Tow is the form most man-made fiber reaches before being cut into staple length and spun. It is often processed into top, sliver or yarn.

Illustrations courtesy of the Celanese Corporation.

Personalized Quality LABELS
Printed in Black with Red Border on White Cotton
TO SEW INTO THE LOVELY THINGS YOU MAKE

Actual Size 2 1/4" x 1 1/4"

Prices 40/\$5.25 - 70/\$7.25 - 100/\$9.25
(prices are for one name and one style only)

NAME TAPES for School, Camp or Home
100 Name Tapes \$4.00
200 Name Tapes \$6.00

Please enclose self-addressed stamped envelope
(2 postage stamps for 70 or more labels)

Approximately **10 DAY DELIVERY**
Enclose check or M.O. in U.S. Funds
IDENT-IFY LABEL CORP. Dept. WJ
P.O. BOX 254, BROOKLYN, N.Y. 11214

WEAVING SUPPLIES

WARP YARNS & FILLERS

CABLE CORD IN COLORS

MACRAME JUTE

SAMPLES 1.25

**E. F. SHAW & COMPANY,
INC.**

SUCCESSOR TO:
TINKLER & CO. INC.

P.O. Box 17
Norristown, PA 19404
(215) 272-2228

fibers will be produced. Man-made fibers will have to take up the slack.

Can we expect any new fibers? It is doubtful whether there are any chemicals with cross-linked molecules left that have not been tried. Surely there will be new types of existing fibers, finer deniers, higher strengths, and, hopefully, some types that will provide more comfort to the wearer, but that is all the crystal ball shows at this time.

References

The references listed give the names of the manufacturers of the various fibers, but not the spinners who use the fibers in staple and tow form. *Davidson's Bluebook* lists the textile mills in the United States and is available in almost every library.

Textile World. Deskbook of World Fibers, McGraw Hill, Chicago. Annual.

Modern Knitting Management Man-made Fiber Deskbook, Vista Publications, Inc., annual.

Textile Industries Man-made Fiber Variant Chart, Textile Industries, annual.

Modern Textile Business: US Manmade Fiber Producer's tables of deniers and filaments, Vista Publications, Inc., annual.

Handbook of Textile Fibers, J. Gordon Cook, Merrow Publishing Co., Ltd., Durham, England, 1984.

Editor's note: A dictionary of textile industry terms, *The Manmade Fiber and Textile Dictionary*, is available free from the Celanese Corporation, 1211 Avenue of the Americas, New York, New York, 10036. Some of the definitions in the glossary are from this reference.

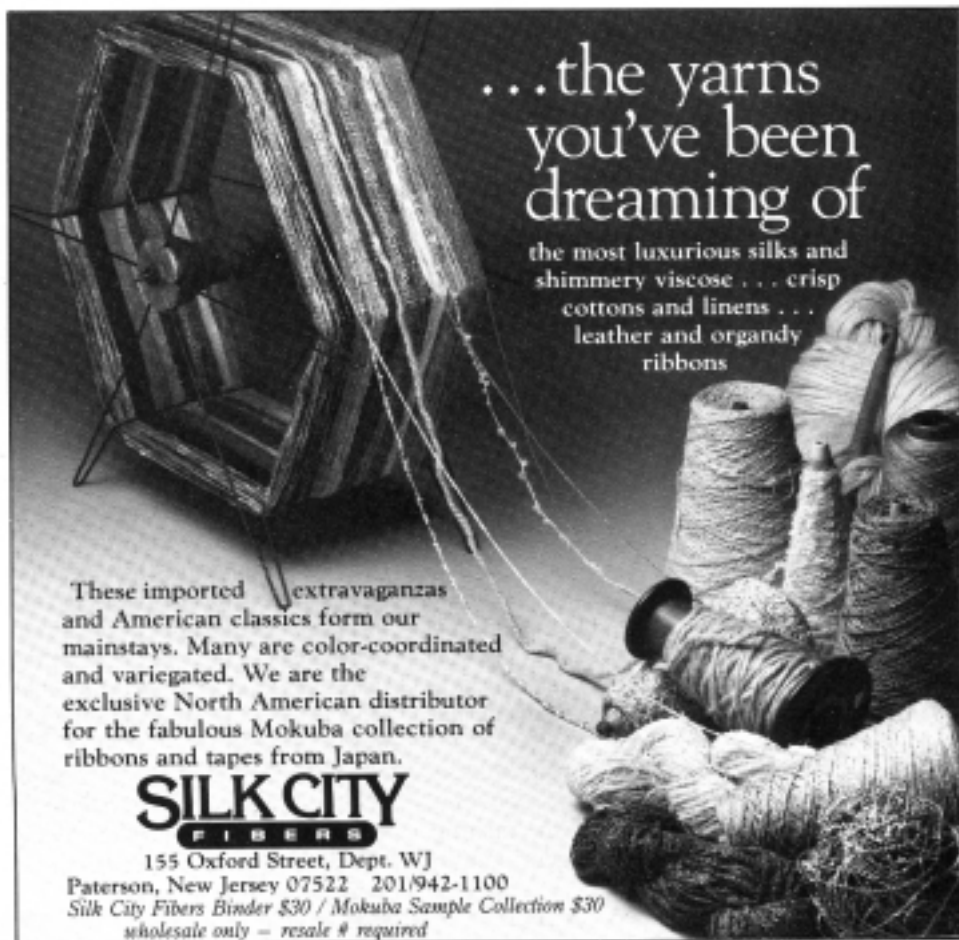

...the yarns
you've been
dreaming of

the most luxurious silks and
shimmery viscose... crisp
cottons and linens...
leather and organdy
ribbons

These imported extravaganzas
and American classics form our
mainstays. Many are color-coordinated
and variegated. We are the
exclusive North American distributor
for the fabulous Mokuba collection of
ribbons and tapes from Japan.

**SILK CITY
FIBERS**

155 Oxford Street, Dept. WJ
Paterson, New Jersey 07522 201/942-1100
Silk City Fibers Binder \$30 / Mokuba Sample Collection \$30
wholesale only - resale # required

**ETHNIC
TEXTILES**

Summer 1985
The Weaver's Journal

Doublejack

OR

Sink the Floating Selvedge

by William Koepf

MY FIRST OVERSHOT weaving was Lee's Surrender. Although I enjoyed weaving it, I did not enjoy examining the selvedge. I was advised to try a floating selvedge, which meant that the shed opening would be cut in two by the selvedge threads at each end; not an ideal situation, in my opinion. I also would have to be sure that the shuttles entered and left the shed, over and under the selvedge warps, in that order.

I felt that the loom itself should take the responsibility for all selvedge control, so I started drawing designs of simple machines. I realize that I could have invested in a large dobby loom, to get the kind of selvedge control that I wanted. But I did not have that kind of money to spend on a hobby.

Doublejack is a device that eliminates the need for a floating selvedge when weaving with two shuttles, as with overshot, or when weaving with four shuttles, as with a bound weave. Doublejack can be mounted on the side of the loom, or on a frame or false castle above the loom, or even suspended from the ceiling over the loom. It manipulates the selvages in accordance with the number of shuttles used in the particular design, using pulleys and cords to raise the correct selvedge heddles as needed.

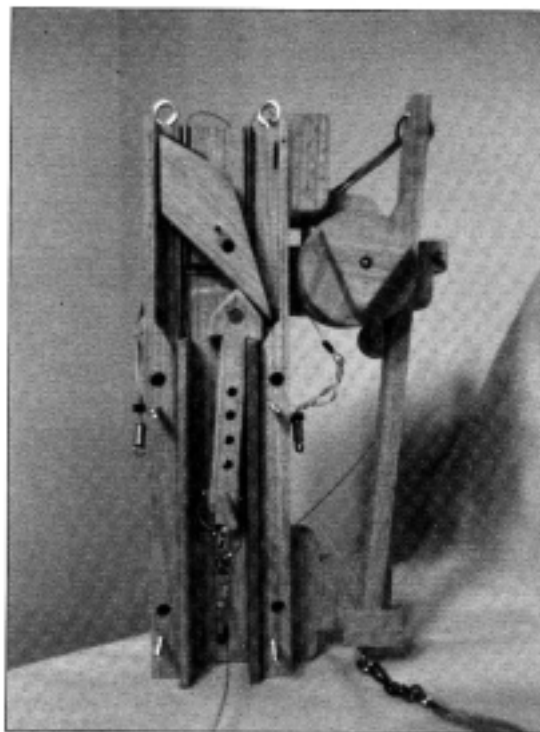

Doublejack interior, hook is about to contact cam to switch over to the other side.

I have restricted the project mostly to wooden parts as a weaver of long ago might have done. I know that this could have been built using aluminum, or electronics and relays, but I wanted no electricity on my loom. Doublejack uses only the weaver's legs for power, and gravity to aid the switching motions.

Like certain wall clocks, Doublejack must be mounted vertically, or it will not work.

The Doublejack design is a cousin to the old "Jack-in-the-Box" design described in Luther Hooper's book, *Handloom Weaving*, published in 1920. A Jack-in-the-Box will select the

Doublejack on Mr. Koepp's loom, breast beam on the left. Loom side is 5 inches wide, the beater is 3 inches wide. Note the counterweights.



next shaft in a predetermined series, by means of two rows of wooden hooks, each connected to a shaft, via a jack, above the shafts. As shown in Hooper's book, the weaver would tread two treadles alternately to make the design.

The Doublejack differs in its ability to alternate its motions, or to "double" one side, or even raise one side four times, for four shuttles to catch correctly. No extra treadles are used to do this. Here is how it works:

Every treadle is tied to one lamm and that lamm is tied to the hook in the Doublejack. The hook pulls a slide, which causes one selvedge to rise; the other selvedge remains down, held there by its weight, or lingo (the old word for it). When the treadle is released, the hook rises, contacts the inner cam, and moves over to the other slide, to raise the other selvedge. The hook goes back and forth, from slide to slide, raising each selvedge alternately, without further attention from the weaver.

If the pattern calls for two shuttles, one for the tabby ground, and one for the pattern weft, Doublejack can be set to give a double rise on each side. This is accomplished by attaching a cord from the doubling arm to the Double-

jack's lamm, using a snap & ring. With this done, the doubling arm rotates a six-toothed wheel which has a triangular cam; the cam moves a stop lever in and out of the path of the rising hook. If the hook is not allowed to rise fully, it cannot contact the inner cam and shift over to the opposite slide. The next time the treadle is depressed, however, the hook will be able to move over.

With the doubling arm working, the sequence will be: right selvedge / rise, right selvedge / rise, left selvedge / rise, left selvedge / rise. The selvedge that does not rise remains lowered because of a small weight (lingo) hung from the bottom of the selvedge heddle. Since only a few warp ends are involved, the sequence does not affect the rest of the warp at all, and the shed is open and unobstructed.

If you are thinking "this will not work with four shuttles," I will explain how it does the four shuttle sequence. The prior example had the Doublejack Hook attached to a lamm (one that is not connected to any shaft) by a cord. You will mark this extra lamm with the letter "A." Now install a second extra lamm, place it next to lamm "A." These lamms can hang from the pivot end by

a chain, if necessary. Mark the second lamm with the letter "B." Lamm "A" is still tied to every treadle, in this case, for a bound weave using four treadles.

A cord goes from the end of lamm "A" to the Doublejack Hook only. Now lamm "B" is tied to treadle #1, and treadle #4 only, and a cord goes from the end of lamm "B," to the Doublejack Doubling Arm only. Neither lamm "A" or lamm "B" is tied to any shaft.

Now the loom will manage the selvages for four shuttles, as long as a consecutive order of treading is used; 1,2,3,4,1,2,3,4.

A tie up for one shuttle or three shuttles will be shown later.

While straight, dry, white oak is preferable, maple, or some other dense hardwood will work, as long as it is dry, and not "green" or unseasoned. A little extra effort spent in finish sanding and surfacing will be repaid in ease of operation. A lacquer finish like Deft™ is also recommended. Wax the internal area where rubbing occurs.

Attaching Doublejack to a multi-shaft loom is simple because of the additional lamms available. On a four shaft loom, an extra lamm or two must be added. This could be a permanent installation or temporary, since the pivot end can be hung by a cord or a chain. The lamm must have a counterweight, so that it will return to the up position; this ensures that the cord from the lamm to the hook is slack, between sequences, to allow the hook to switch over. A pulley above the lamm, and a few steel washers will do the job; I use 3/8 inch steel washers anywhere I need weights, they average about one ounce each, and are cheap.

The position of the Doublejack device in relation to the loom is determined by the position of the pulleys that carry the cord from the selvedge heddles, since they should run in a straight line. Cord lengths will depend on the loom size. Braided steel fishing leader is strong, and will not stretch, it is crimped into soft sleeves with pliers, to make the loop ends.

The following description traces the route of the cords, from the heddle holding the left selvedge. Below the heddle eye is a small weight of four ounces or so, that holds the selvedge down, when no treadle is pressed. (The weight required will vary with warp tensions.)

The cord rises to the top of the

loom, turns on a pulley and runs to a position directly above the Doublejack, over another pulley, and into the Doublejack, to the slide. The slide is drilled to receive the cord, which is held in place by a large knot. (There are two cords like this, one left, one right.)

The treadles are all tied to one lamm, which has a cord leading to the Doublejack. There is a ring and a snap, to allow hooking on of the doubling arm, when desired. The cord enters the bottom of Doublejack and attaches to the hook; it must attach at a point above the dowel, which is the hook's pivot, to eliminate any leverage by the lamm.

The dowel-pivot of the hook provides a point of attachment for the counterweight cord, at its end, either by a screw eye, or a wire through the dowel end. This cord leads to a small pulley, and then down to some open space, where a small counterweight ensures that the hook will rise and meet the interior cam. I placed small swivels (fishing supplies) wherever I could, to avoid cord twist and torque.

Since my loom has an overhead beater, and a high castle, I put four screw eyes in the top of the Doublejack and hung it from the side of the castle, then I stretched a spring down, from the bottom of the device, to the loom frame, for stability. Doublejack works well in this position, but it would work equally well if hung from four screw-eyes in the ceiling; just be sure to have the pulleys for the heddle cords above the Doublejack, closer to the ceiling.

The advantage in using screw eyes and light chain is ease of adjustment to make the device hang truly vertically as it should. (Turn the screw eyes in or out to fine-tune the angle.)

Always use cords that are not elastic, since they waste motion, and Doublejack has only so much available for the selvedge lift.

Experimenters may wish to upgrade the bearings, by using bronze or nylon bearing at the cam axles, and the stop lever axle. The switching motion can be made more positive, by drilling a hole of about 1/2 inch diameter in the top of the hook, and gluing a piece of steel, or lead into the hook, to make it even more top-heavy. The same can be done to the inner cam. This ensures a clean switch by the hook, as it moves to catch the opposite slide.

Further experimentation might

include adding two shafts to a four shaft loom, and using Doublejack to operate the new shafts as a plain weave, from one new treadle. The loom would now be a six shaft, allowing the exploration of new weaving drafts heretofore unavailable to the four shaft weaver. I would operate the two plain weave shafts, by running two cords from each slide, up over one pulley, then split the cords, each over its own pulley, to raise the shaft. The doubling arm would not be used, it would be taken off, or left in the "off" position.

Doublejack Set-up

When one shuttle is used, all treadles are tied to one lamm, which is connected to the hook. The doubling arm and gear are not used.

When two shuttles are used, all treadles are tied to a lamm, which is connected to the hook, the doubling arm is connected to the same cord with

rubber bands, to protect the wooden parts.

When three shuttles are used, tie up as for one shuttle.

When treadling for a bound weave, or block draft, and four shuttles are required, using the same four treadles and sheds repeatedly, two lamm are used to operate Doublejack. One lamm is tied to all of the treadles, and connected to the hook. The other lamm is only tied to the first and the last treadle in the pattern series. For example, when four treadles are used, it is tied to #1 and #4 only, and is connected to the doubling arm with rubber bands, to avoid undue stress to the wooden part.

Bibliography

Hooper, Luthet. *Hand-loom Weaving, Plain and Ornamental* (London: Pitman & Sons, 1920) Chapter XV, Fig. 98.

©1984 WILLIAM KOEPP

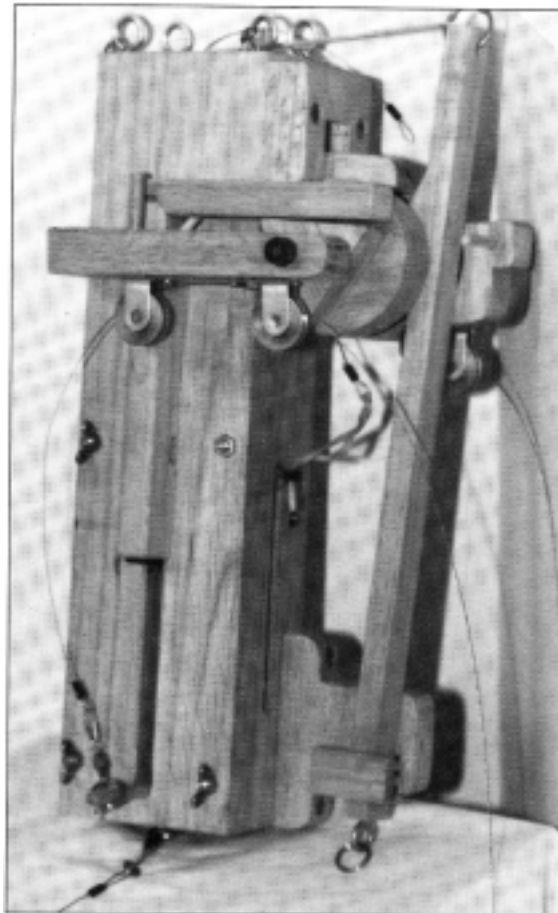

Doublejack front.

First published in *Shuttle, Spindle and Dye-pot*, Winter 1982.

Doublejack

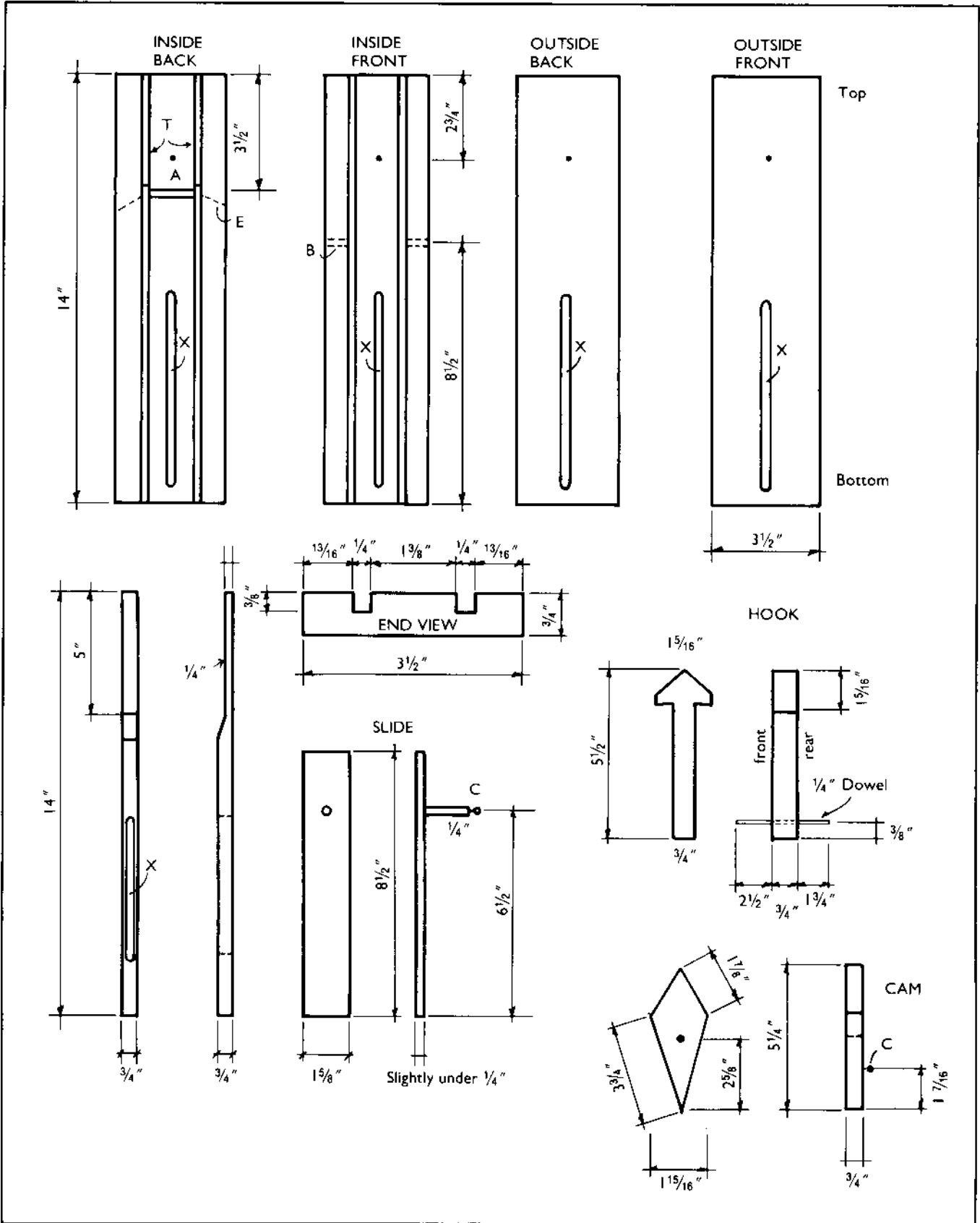

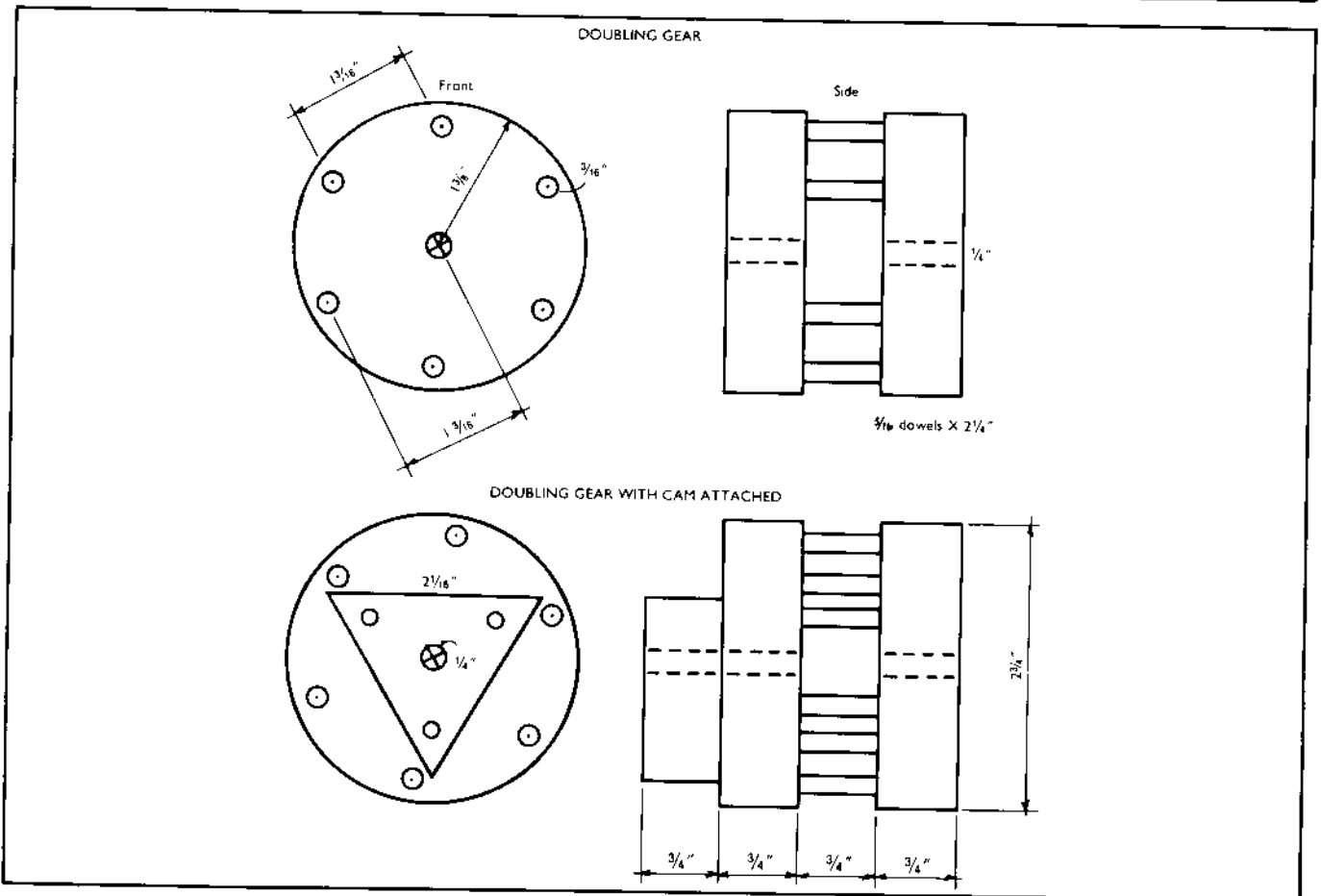
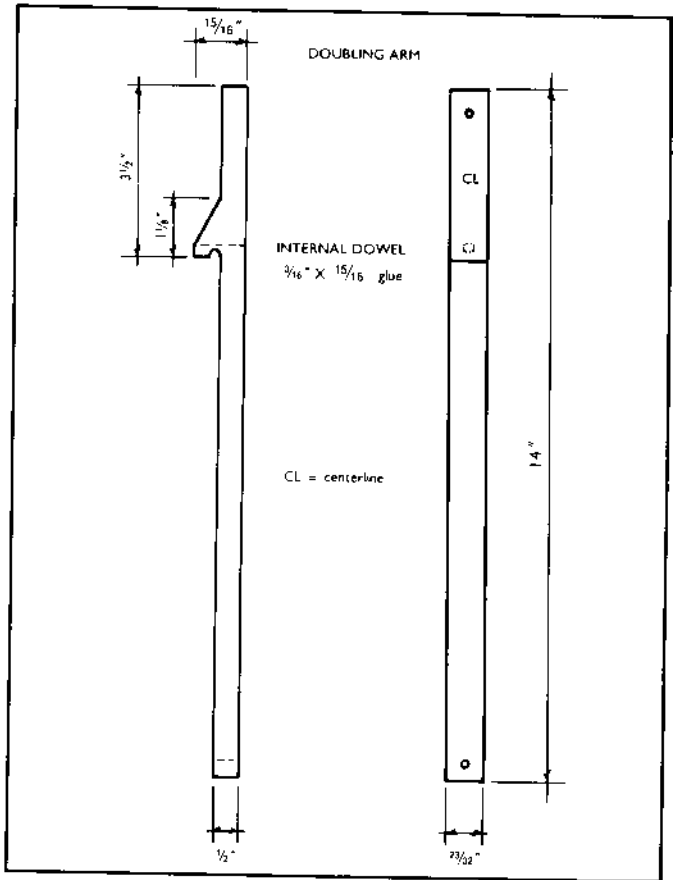
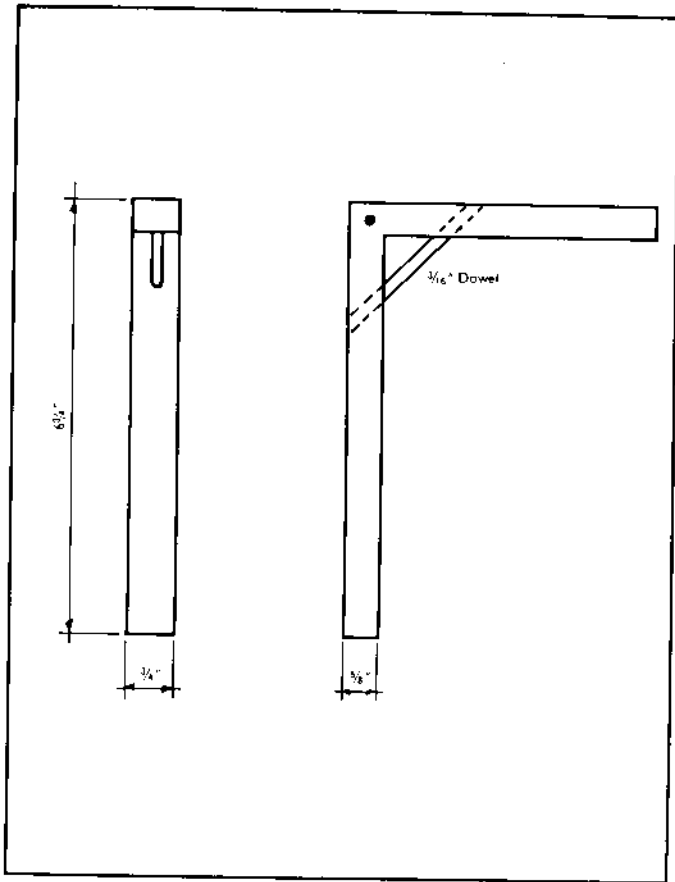

In this 3/4 size sketch,* the weaver has just pressed down a treadle part-way down, the inner Cam has moved, pulled by the taut cord from the right Slide. The Slide has been pulled down by the Hook, which is connected to a Lamm.

Although many details have been left out for clarity, the cords (A) from heddles to the Slides can be seen going behind the Cam, the cords (B) from the Slide-dowel ends, to the Cam, with rubber bands (F) serving as shock-absorbers. The Slide-dowel ends have small screw-eyes (C).

The Hook is pulled by a cord equipped with a swivel to eliminate twisting (D).

The sides of the frame are held to the back by screws (G), and pins (E) made from thin finishing nails.

Hanger bolts - (H).
*not really to scale

The following drawings will show the parts for Doublejack; all measurements are in inches, and fractions; the wood used was white oak.

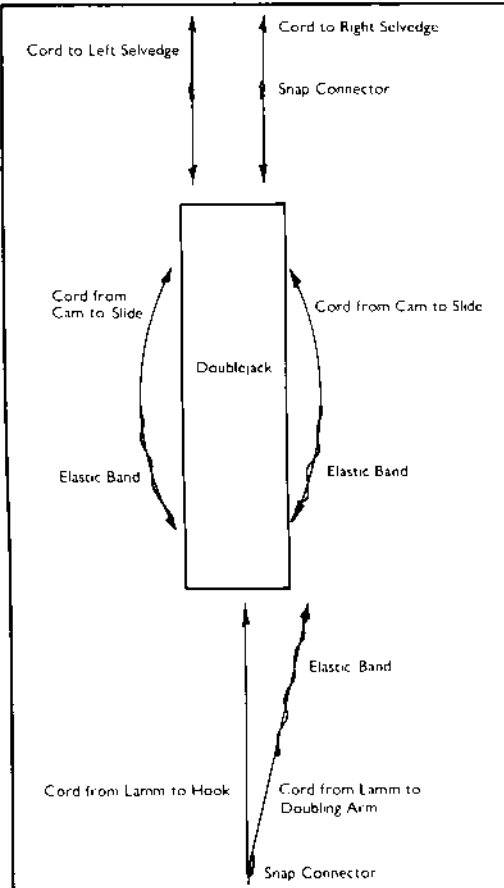
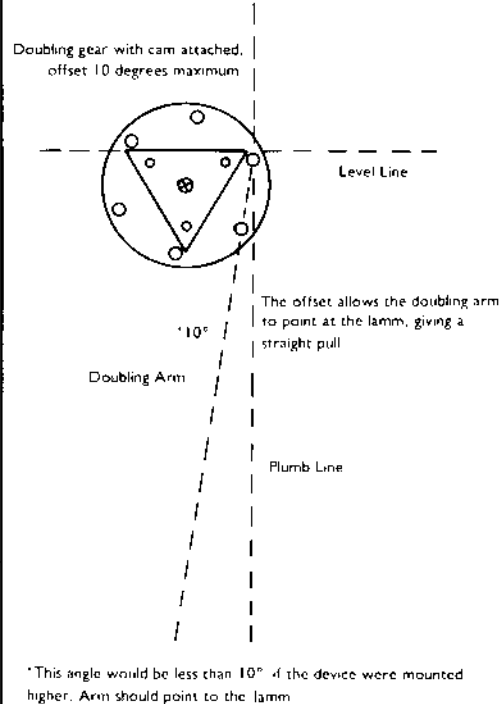
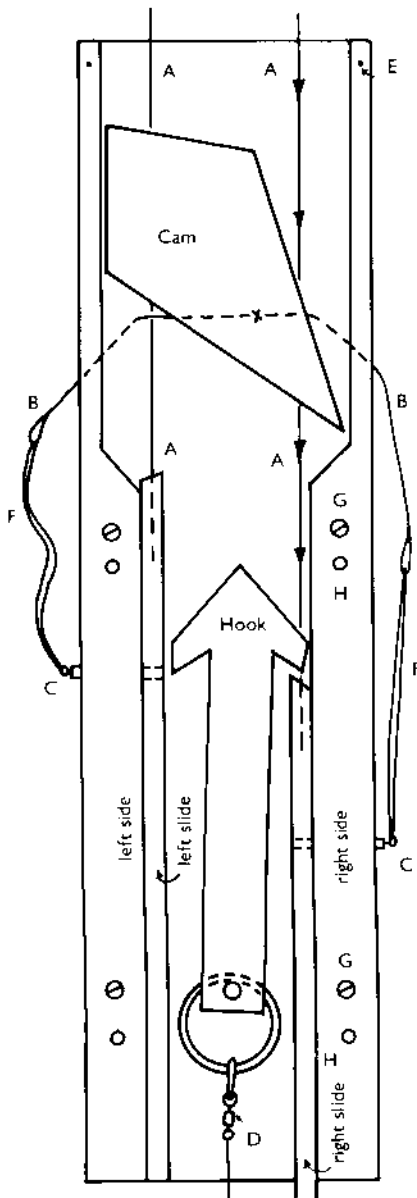

DOUBLEJACK

Sketch below shows the *exterior* side view of the cord between the slide and the *Cam*.

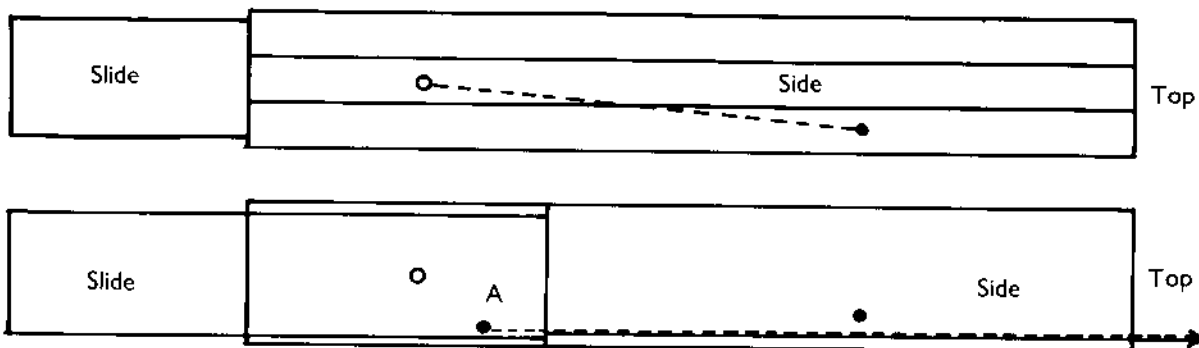

Sketch above shows the *interior* side view of the slide and its cord, that goes to the *heddle* and the heddle weight. Cord is secured inside of the slide by a knot (A).

The pulleys can be hung from the ceiling, for a jack type loom.

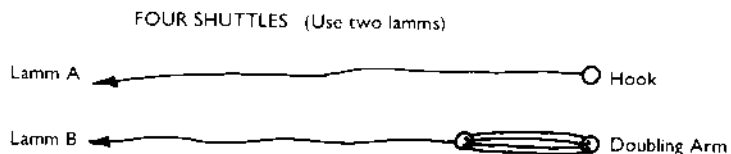
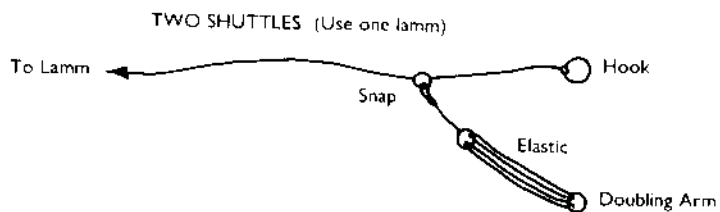
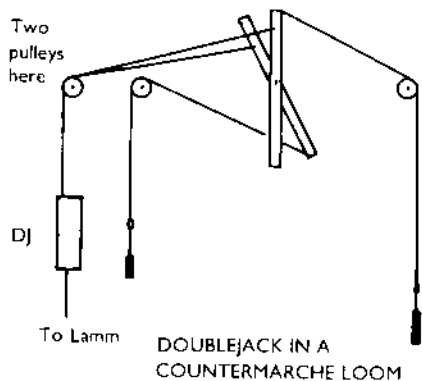
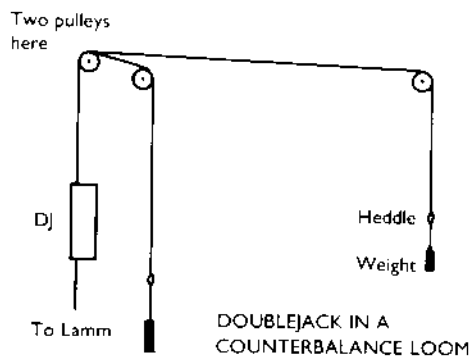

FOUR SHUTTLES
(Tabby treadles not shown.)

Possible Block/Bound Treading



The middle treadles do not pull the doubling arm, only the first & last treadles in the sequence.

Light Weight Lamms

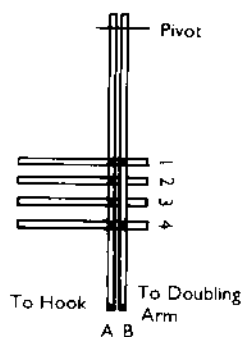

One shuttle: Use one lamm, the doubling arm is not used to stop the hook.
 Three shuttles: Same as one shuttle.
 (Although Doublejack was made for a two or a four shuttle weave, where a selvage problem exists, I thought I'd include the above information, just in case anyone asked).

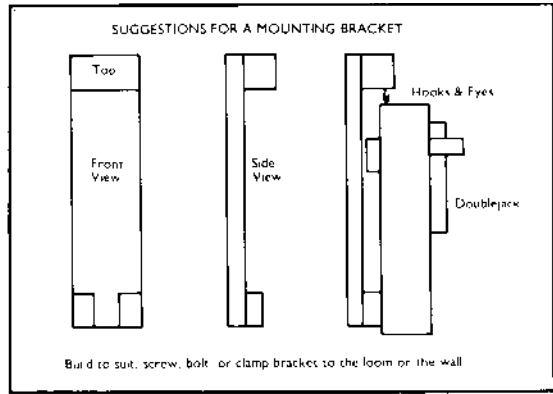
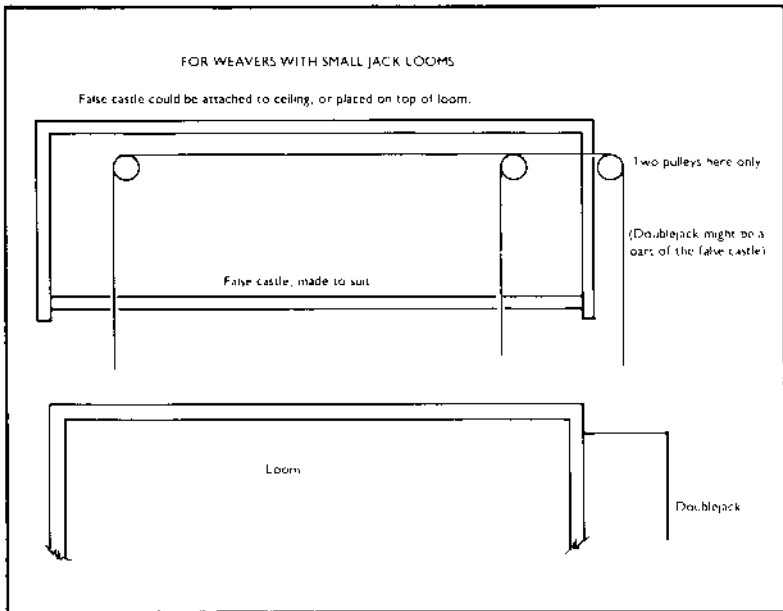

Doublejack Plans

A complete set of plans with detailed instructions for building the Doublejack device is available for \$5.50 from *The Weaver's Journal*, PO Box 14 238, St. Paul, MN 55114.

IN THE NEXT ISSUE

Designs by this prominent Swedish artist of the early 20th century are still being woven today in the atelier in southwestern Sweden that is devoted to carrying on her work. The Spring *Weaver's Journal* will feature a look at the life and work of Måås-Fjetterström by Claire Selkurt. At right, the studio showroom in Båstad.

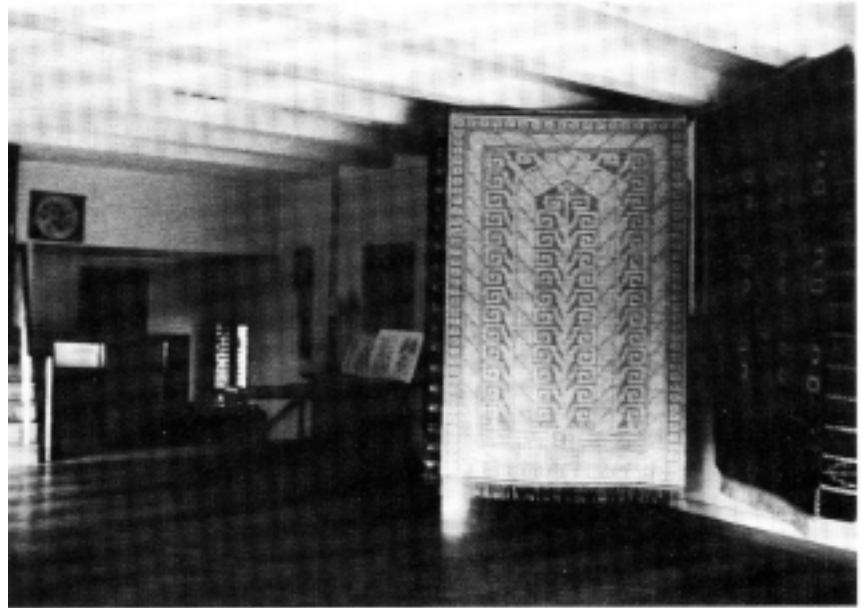

The tapestries and rugs of Märta Måås-Fjetterström

Weaver's Journal Publications

Books

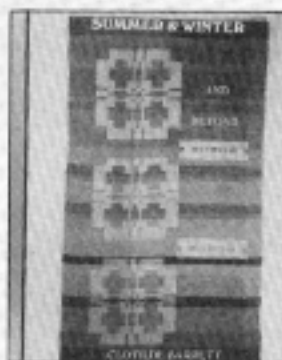

1

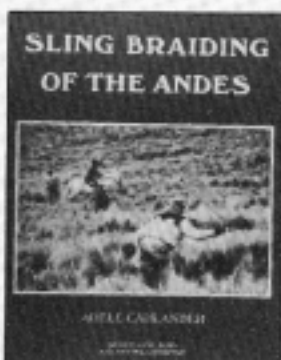

2

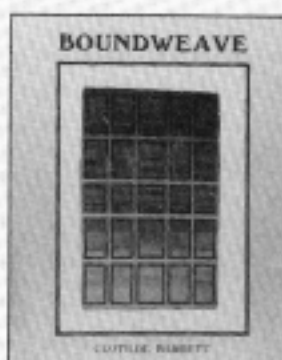

3

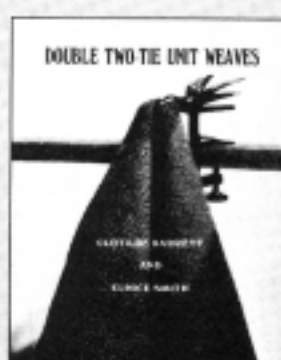

4

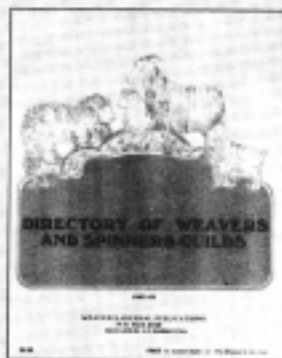

5

1. Summer and Winter and Beyond—2nd revised edition by Clotilde Barrett

This monograph deals with classical ways of weaving this versatile fabric structure, including multiple shaft block design and polychrome weaves, and explores unusual interpretations. A four shaft four block version of S/W suitable for rugs and S/W boundweave techniques are included. \$6.00

2. Sling Braiding of the Andes by Aileen Cablander with Elaine Zorn

This monograph is the first true documentation on the way the intricately braided Andean slings are constructed. Step-by-step instructions with clear pattern diagrams and working sequences, make it possible to reproduce a vast number and variety of these unusual and little known braids. \$10.00

3. Boundweave by Clotilde Barrett

Boundweave produces a weft faced fabric suitable for rugs and tapestries. A multitude of patterns are possible by developing simple drafts and

careful color selection of the weft. The principle of shaft switching is included. The text is beautifully illustrated with color, black/white photographs and line drawings. \$10.00

4. Double Two-Tie Unit Weaves by Clotilde Barrett and Eunice Smith

Double two-tie unit threading drafts give the 8-shaft weaver the best opportunity to experiment with a vast number of exciting weave structures without rethreading the loom. Hundreds of variations of this threading system can be woven. The design theory is explained in a clear and comprehensive way. Each step is illustrated with complete drafts, samples, and photos. \$12.00

5. Directory of Weavers and Spinners Guilds

An updated annual listing of guilds in the United States and abroad. Guilds are listed alphabetically within each state or country. Federations and organizations of interest to weavers are also included. \$2.50

Note Cards

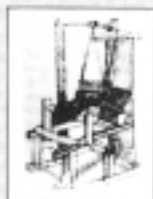

1



2



3



4



5



6



7



8



9

1. Japanese weaver
2. Japanese spinner
3. Bolivian weaver
4. Navajo weaver
5. Angora goat
6. Sheep
7. Llamas
8. South American spinner
- 9a. Christmas card (with message)
- 9b. Christmas card (without message)

All cards come with matching envelopes.

Special Sale
\$2.00/pkg.

Weaving Record Sheets



4-s. 4 shafts (pad of 20)



8-s. 8 shaft (pad of 20)

Weaver's Journal Publications



Subscription Rates

In U.S.A.: 1 year—\$15.00

2 years—\$29.00

3 years—\$42.00

Outside U.S.A.: 1 year—\$18.00

2 years—\$34.00

3 years—\$50.00

Weaver's Journal Back Issues

Qty.		Amt.
___	Vol. III, No. 1, July 1978 (issue 9)	\$2.50
___	Vol. III, No. 3, Jan. 1979 (issue 11)	\$2.50
___	Vol. III, No. 4, Apr. 1979 (issue 12)	\$2.50
___	Vol. IV, No. 1, July, 1979 (issue 13)	\$2.50
___	Vol. IV, No. 2, Oct. 1979 (issue 14)	\$2.50
___	Vol. IV, No. 3, Jan. 1980 (issue 15)	\$2.50
___	Vol. IV, No. 4, Apr. 1980 (issue 16)	\$3.00
___	Vol. V, No. 1, July, 1980 (issue 17)	\$3.00
___	Vol. V, No. 2, Oct. 1980 (issue 18)	\$3.00
___	Vol. VI, No. 1, July 1981 (issue 21)	\$3.00
___	Vol. VII, No. 1, July 1982 (issue 25)	\$4.00
___	Vol. VII, No. 2, Oct. 1982 (issue 26)	\$4.00
___	Vol. VII, No. 3, Jan. 1983 (issue 27)	\$4.00
___	Vol. VII, No. 4, Apr. 1983 (issue 28)	\$4.00
___	Vol. VIII, No. 1, July 1983 (issue 29)	\$4.00
___	Vol. VIII, No. 2, Oct. 1983 (issue 30)	\$4.00
___	Vol. VIII, No. 3, Jan. 1984 (issue 31)	\$4.00
___	Vol. VIII, No. 4, Apr. 1984 (issue 32)	\$4.00
___		Total

Standing order discounts apply.

Other Weaver's Journal Publications

Quantity		Unit Price	Total
_____	<i>Summer and Winter and Beyond</i> , Barrett	\$6.00	_____
_____	<i>Boundweave</i> , Barrett	\$10.00	_____
_____	<i>Double Two-Tie Unit Weaves</i> , Barrett & Smith	\$12.00	_____
_____	<i>Sling Braiding of the Andes</i> , Cahlander	\$10.00	_____
_____	<i>Directory of Weavers and Spinners Guilds</i>	\$2.50	_____
Weaving Record Sheets: _____	4-shaft	\$2.00	_____
(pads of 20) _____	8-shaft	\$2.00	_____
_____	Shaft switching plans by Peter Collingswood	\$5.00	_____
TOTAL ORDER			=====

Note Cards

Folder with 10 cards: \$4.00

(indicate design by item number and brief description).

Quantity	Item No.	Description
_____	_____	_____
_____	_____	_____
_____	_____	_____

Special Sale

\$2.00/pkg.

Postage and handling

\$1.50 for the first item ordered and 25¢ for each additional item. **Outside the U.S.:** \$2.00 for first item and 50¢ for each additional item.

Name _____

Address _____

city state country zip

Phone _____

TOTAL AMOUNT OF ORDER \$ _____

plus postage & handling _____

TOTAL amount enclosed \$ _____

Please make checks or money orders in U.S. funds payable to *The Weaver's Journal*, P.O. Box 14238, St. Paul, MN 55114. In Minnesota, please add 6% sales tax (no tax on subscription orders).

◆ COMPLEX LOOMS ◆

DOBBY from page 13

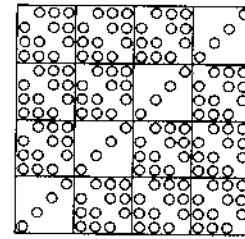
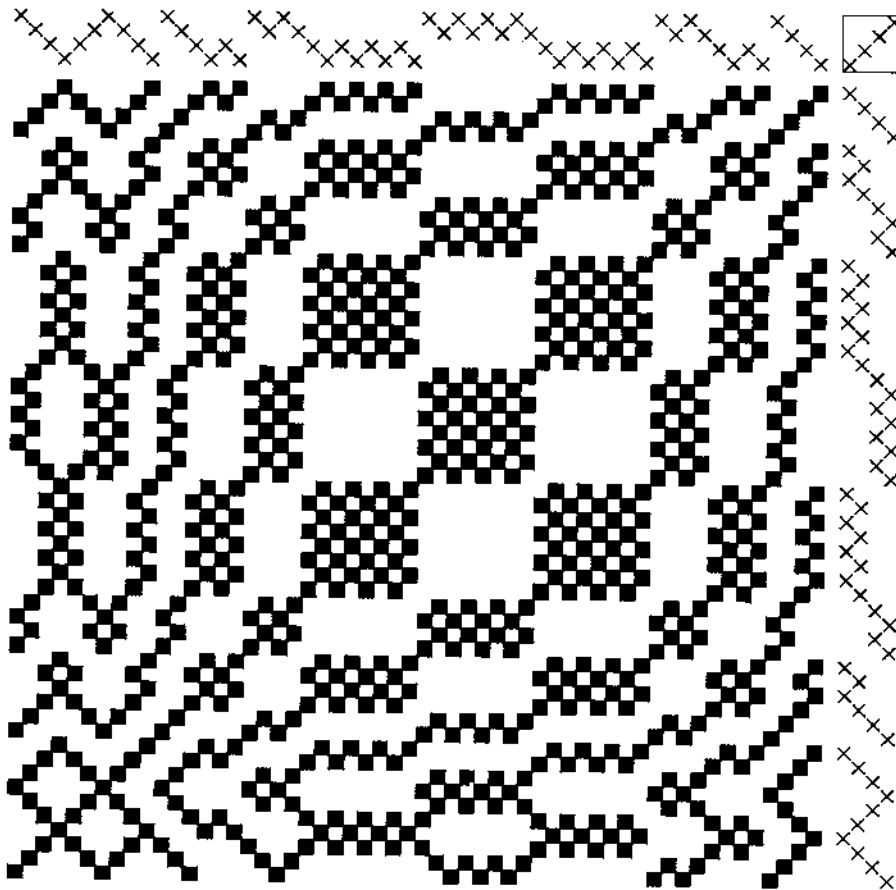

Figure 9. Profile draft, and drawdown figure 2 threading with twill diaper tie-up, 4-harness blocks.

ers, Abraham Allen and Daniel Stephenson, and now in the collection of the Department of Textiles, The Art Institute of Chicago (Figure 11). In the case of this draft, twill blocks are formed by 4- or 5-thread repeats in point twill threadings; there are 3 blocks formed, which means that 12 harnesses are necessary. A striking and unusual pattern results. (Figure 12) This tie-up may be used with the master threading in figure 2.

From a single threading, then, we have been able to affect six fabrics, very different in appearance. The major changes have been in the tie-up, i.e., the pegging of the dobby chain lag. The treadling order has been "as drawn in" and with the exception of the point twill with foundation tabby, all fabrics were woven with one shuttle.

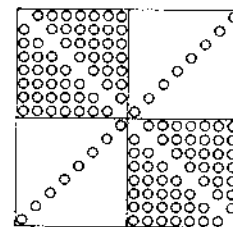
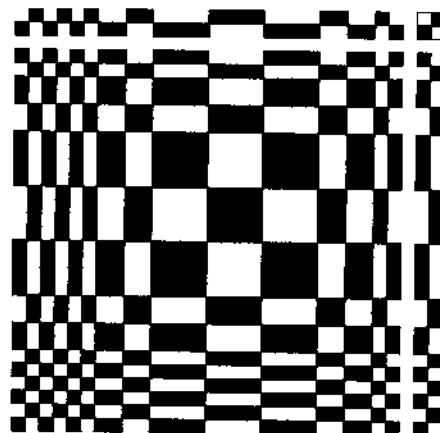

Figure 10. Profile draw-down, for figure 2 threading with twill diaper tie-up, 8-harness blocks.

A few comments on the technical aspects of the dobby loom are in order here. Since there are normally 50 wooden "slats" in the chain lag, it is best to think through the treadling order in order to optimize the use of all fifty slats. If, for example, the border consists of 4 identical twill sequences of 16 treadlings, the first 16 treadlings should be pegged and the chain reversed to repeat the sequence the remaining 3 times. Other motifs with the patterns may be repeated reversed, or omitted, as needed. Careful counting of the number of slats advanced, reversed, or omitted must be made to avoid treadling errors. Small colored adhesive dots may be affixed to the relevant chain lag slats to aid in pattern sequence identification.

When using a different tie-up in a single piece using the same threading, it may be easier to make up two separate chain lags before weaving so that one can quickly be substituted for the other once weaving has begun. It should be remembered that the pegged sections represent un-raised harnesses so tie-up markings indicating weft floats should not be pegged. Also, patterns requiring a tabby foundation must have the tabby pegged alternately with the pattern pegging.

While the pegging of the chain lag and its subsequent manipulation for

varying pattern effects may seem time-consuming, it is no more so than huddling under a loom, tying and re-tying tie-up cords for 16 harnesses.

Further, the use of pegs encourages the adaptation of treadling and subsequent patterns and weaves while actually weaving a piece. When the chain lags are kept as pegged, a permanent record of the tie-up and treadling order results. The dobby loom is thus an interesting and useful tool for multiple-harness weaving.

Figure 11. Point-twill with plain weave foundation, 12-harness, from the Allen-Stephenson Draft Book, courtesy of the Art Institute of Chicago.

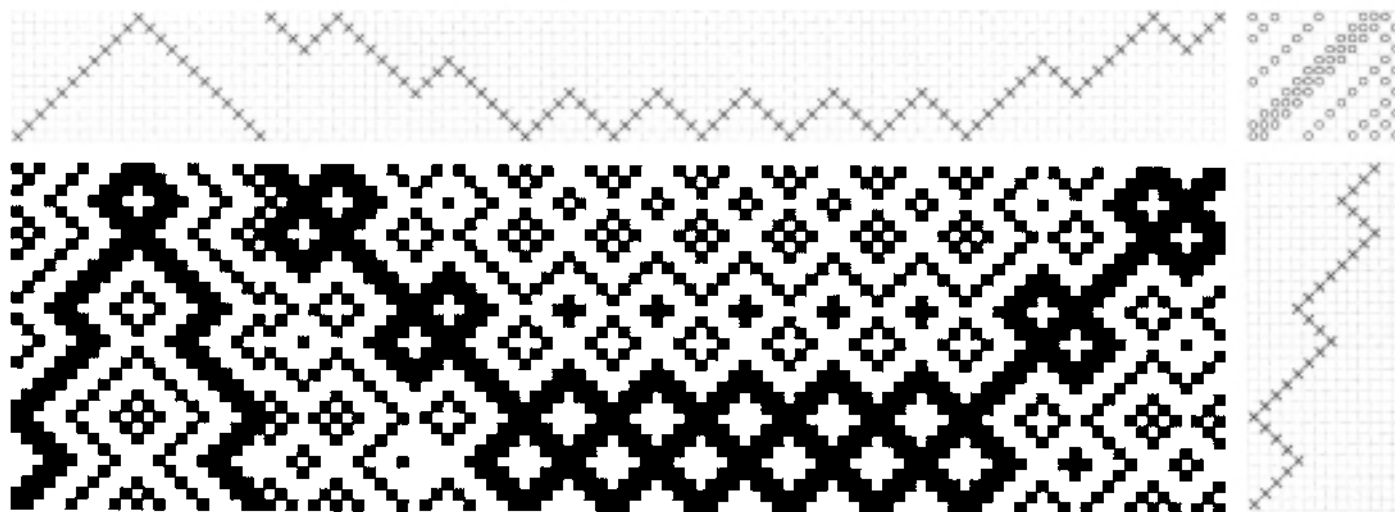
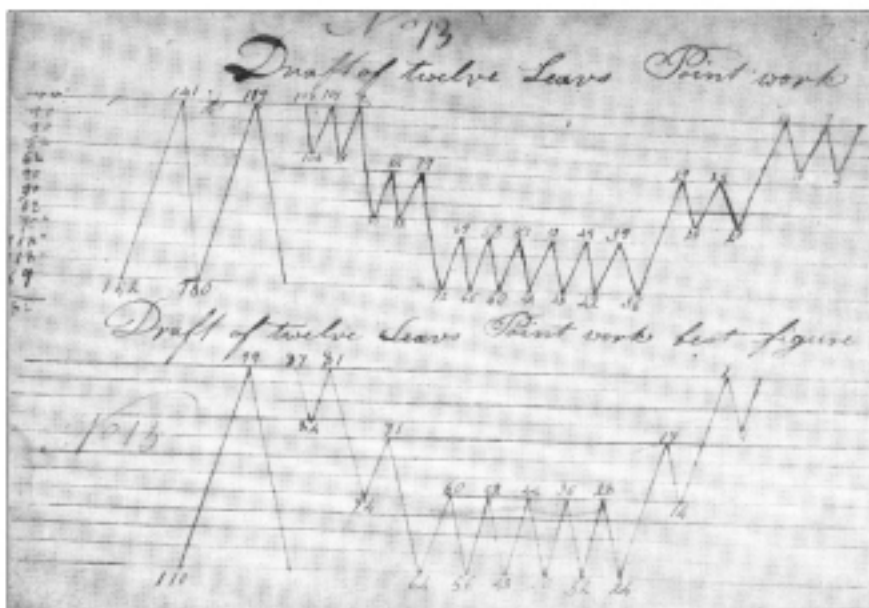

Figure 12. Draw-down of point twill draft with plain-weave foundation.

◆ MEET THE AUTHORS ◆



Rose Mary Allen has a degree in Textile Design with a minor in Costume Design from the University of Minnesota. In her work as a teacher and consultant, sharing her knowledge of weaving plays an important part in her life. She gets great pleasure out of helping others to discover their ability to create with fiber.

Rose currently lives in a restored Victorian building in St. Paul, with her loom located conveniently in the living room.



Mary Ann Butterfield is Assistant Textile Conservator at the Minneapolis Institute of Arts. She holds an undergraduate degree in Museum Studies from Metropolitan State University, Minnesota, and has completed internships in the Textile Department at the Minneapolis Institute of Arts and the Textile Conservation Workshop in South Salem, New York. She is especially interested in the preservation of historic textiles, not only in the museum context, but by individual collectors as well.

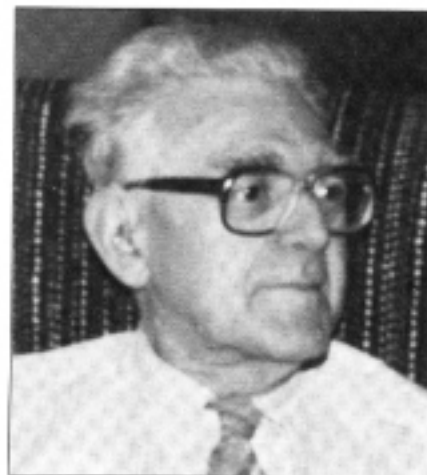

accessories and specialties, tufted fabrics, chenille goods, menswear fabrics, ladies' fashion fabrics, neckwear, pile fabrics, upholstery and drapery fabrics. He is a hand-weaving enthusiast as well, and many of our readers will remember his columns in *Handweaver and Craftsman* magazine.

Susan Hick and the loom were first introduced in 1973, and they have been fast friends ever since. Researching "Fashion Trends" provides a bonus for Susan. Her special interest is in weaving yardage for clothing, which she sells through Fiber Matrix, a cooperative endeavor in Denver, Colorado.



Fiber artist, teacher, writer **Philis Alvic** graduated from the School of the Art Institute of Chicago in 1967. Since that time she has frequently exhibited her work. At her studio in her home in western Kentucky, Philis weaves loom-controlled wall hangings and investigates weave structures. She shares her experience and opinions about weaving through lectures, workshops and writing.

Ruth Arnold weaves one-of-a-kind and limited-production garments in her Golden Valley, Minnesota studio. She has catalogued ethnic garments in the Textile Department of the Minneapolis Institute of Arts, and teaches floor loom weaving at the Weavers Guild of Minnesota.



Kerry Evans of Milwaukee Wisconsin is a self-taught weaver and designer. She has exhibited her handwoven clothing widely and presented workshops on loom-shaped garment design at many guilds and conferences throughout the country. She is the author of *Treadled Togs: A Pattern Book of Loom-Fashioned Clothing* and *Applying the Pulled Warp Technique to Loom-Shaped Clothing*.

Walter Hausner was born and educated in Vienna, Austria, and is a graduate of the Vienna College for Textile Technology. He worked in the textile industry in Austria, Czechoslovakia and Great Britain, before coming to the United States in 1948. He has been involved in the production of fashion



Marilyn Emerson Holtzer combines a background in mathematics and chemistry with her fiber art. She is a self-taught weaver, but approaches her weaving in the same professional manner that she uses in her scientific research at Washington University in St. Louis. Marilyn has developed several weaving techniques which have been described in various publications, and her work has appeared in many exhibits. The card-woven vest featured in her article received awards at the 1984 Midwest Weavers Conference.



Lucy Anne Jennings began weaving seven years ago at Northern Arizona University, Flagstaff. She is currently employed as a first grade teacher in Klamath Falls, Oregon. Her creative time is spent exploring surface design and fabric structure within the mediums of weaving, basketry, spinning, doll sculpture and silkscreen printmaking.



Diana W. Lockwood has a Master of Fine Arts degree in weaving and textile design from the University of Hawaii, emphasizing ecclesiastical art. Her work has won recognition both nationally and internationally. She has been artist-in residence at Grunewald Guild liturgical art center, and has conducted workshops on a variety of fiber techniques in many locations. Her studio, The Symbolic Shuttle, is in Kailua, Hawaii.

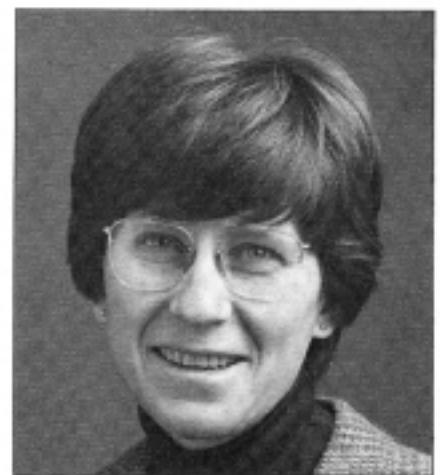

Lotus Stack is the Textile Curator at the Minneapolis Institute of Arts. Her undergraduate studies were completed in California and graduate work done at the University of Minnesota. Lotus was a National Museum Act intern in the Metropolitan Museum of Art Textile Conservation Department and has done further studies in Europe. Her special interests are woven structure and the history of textile technology.

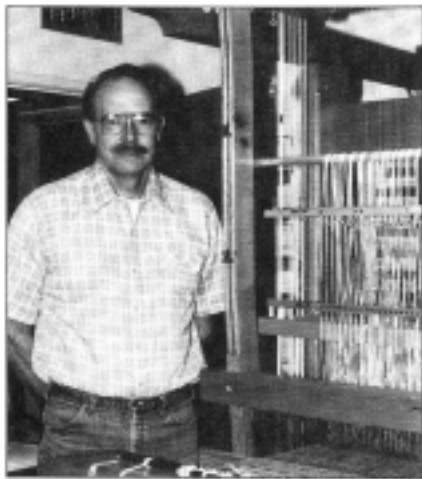

William Koepf's interest in weaving developed after building a counter-balance loom for his wife in 1975. A few years later, he drew plans for, and constructed a larger countermarche loom that he uses today. He lives in Bakersfield, California and works as a deputy sheriff, with weaving sharing time with other interests, including wood-working, back-packing, chess, and collecting old weaving books.



Elisha Renne, a Florida native, is currently a graduate student at the University of Minnesota, Department of Design, Housing and Apparel, specializing in the study of West African textiles. She also runs a weaving business, Arcadia Handweaving, which sells handwoven table linens to craft shops in eight states. Elisha's interest in multiple-harness weave structures came from her love of handwoven coverlets, and the desire to know how to weave them.

Nina Winchester received her B.F.A. in Weaving from the Cleveland Institute of Art. She has exhibited her work throughout Ohio and recently illustrated Roslyn Hahn's new book, *Textiles for Today's Church*.

Micheline Thabet, Quebec, Canada, has done extensive research on braided and woven bands. Her experiments with ancient and ethnic techniques have led her to develop various innovative methods for producing bands. She gives workshops, teaching braiding techniques. Micheline is also fascinated with all types of loom laces and published an article on Tarascan lace in the Spring 1984 *Weaver's Journal*.

WRITERS!

Do you have an idea for an article? *The Weaver's Journal* is happy to encourage new authors and ideas. Send for our writer's guide in care of Susan Larson-Fleming, Associate Editor, P.O. Box 14238, St. Paul, MN 55114.

◆ CALENDAR ◆

EXHIBITS, FAIRS, FESTIVALS

CALIFORNIA

Fullerton: South Coast Weavers' Guild and the Museum of North Orange County announce "Handwoven in Southern California," April 13-June 9, 1985, The Museum of North Orange County, 301 N. Pomona Ave. Fullerton, California 92632.

San Mateo: The Great American Needlework & Sewing Fair has announced show dates of March 1, 2, 3, 1985 for its 2nd Annual Consumer Exposition. Location for the Northern California edition will be the San Mateo Fairgrounds, San Mateo, California. *For vendor/exhibitor prospectus or additional information:* Ron Baker, Show Director, Great American Fairs Inc., 801 Mahler Road, Suite 103, Burlingame, CA 94010.

DISTRICT OF COLUMBIA

Washington, D.C.: The Textile Museum's exhibition "Temple, Household, Horseback: Rugs of the Tibetan Plateau," which opened November 1, 1984, originally scheduled to be on view through January 6, 1985, has been extended through March 31, 1985. The exhibition, "The Artist and the Quilt" will be on view at The Textile Museum from January 24-March 10, 1985. This exhibition presents the collaborative efforts of artists and quilters through the display of approximately 20 quilts and the original artwork from which they were adapted.

GEORGIA

Atlanta: The Chattahoochee Handweavers Guild, Inc. of Atlanta, Georgia will sponsor a traveling exhibition, "Georgia Spirit of Handweaving '85," February 3-28, 1985, Lamar Dodd Art Center, La Grange College, La Grange, GA; March 3-30, 1985, McElreath Hall, Atlanta Historical Society, 3101 Andrews Dr., NW, Atlanta, GA.

ILLINOIS

Chicago: The Lithuanian Folk Art Institute of Chicago presents "Lithuanian Folk Art: A Continuing Tradition," February 15-17, 22-24, March 1-3, 1985 at the Ciurlionis Art Gallery, 5620 S. Claremont Ave. Chicago, IL 60636.

INDIANA

Indianapolis: The Indianapolis Museum of Art, 1200 W. 38th St., Indianapolis, IN, 46208 announces "Art in Motion: Wearable Art '85," March 2-17, 1985.

MAINE

Rockland: Maine Guild of Spinners and Weavers announces their biennial juried

show "Challenge," including an exhibit of historic Maine textiles plus examples of those being created today. Farnsworth Museum, December 7-January 27, 1985.

NEW MEXICO

Los Alamos: January 11-February 3, 1985. An exhibit of Mexican weavings and related artifacts, with documentation, will open at Fuller Lodge Art Center, 2132 Central Ave., Los Alamos, NM. This exhibit is part of the Peter Castine Collection. Mr. Castine has been collecting weavings, from rugs to native clothing, since the early 1960's.

NEW YORK

New York City: "For the Floor," an international exhibition of contemporary artists' rugs, January 25-May 11, 1985. The American Craft Museum II, International Paper Plaza, 77 West 45 Street, NYC.

New York City: The Cooper-Hewitt Museum, 2 E. 91st St., N.Y., N.Y. announces their schedule of new exhibitions for early winter, 1985: "Fabled Cloth: Batik from Java's North Coast," January 29-April 28, 1985; "Cut Paper," February 12-May 12, 1985.

New York City: "Collaboration 6," Feb. 12, 1985. Fashion, interior design, architecture and theater unite on Peter Cooper's birthday, to celebrate the 125th anniversary of The Cooper Union for the Advancement of Science and Art. *For information:* Pauline V. Delli-Carpini, Executive Director of the Resources Council, 979 Third Ave., New York, N.Y. 10022 (212) 752-9040.

Stony Brook: Stony Brook juried fiber arts exhibition, April 22-May 10, 1985, includes a lecture by Nell Znamierowski on "The Contemporary Scene in Wall Hangings and Fiber Sculpture," on April 22. Craft Center, Stony Brook Union, State University of New York at Stony Brook, Stony Brook, New York 11794.

PENNSYLVANIA

Philadelphia: "The Art of the Weaver," the 32nd annual exhibition by the members of the Philadelphia Guild of Handweavers will open March 3 at Woodmere Art Gallery, 9201 Germantown Ave., Philadelphia, and will continue through March 31, 1985.

WASHINGTON

Bellevue: "Wearable Art Fashion Show," a juried competition sponsored by the Bellevue Art Museum, 301 Bellevue Square, Bellevue, WA 98004, will be held April 25, 1985.

WISCONSIN

Milwaukee: "Fiber R/evolution," a national invitational and juried exhibition, will be held at the University Art Museum, the University of Wisconsin-Milwaukee, February 7-March 30, 1986, and will travel to national museums for the remainder of 1986 and 1987. The exhibition will be composed of two sections: an invitational and a juried section. The emphasis will be on the fine art and sculptural aspects of fiber. *For information:* Public Relations Department, Milwaukee Art Museum, 750 N. Lincoln Memorial Dr., Milwaukee, WI 53202.

Stevens Point: The 13th Annual Festival of Arts will be held March 24, 1985 at the University of Wisconsin-Stevens Point Fine Arts Building. *For information:* P.O. Box 872, Stevens Point, WI 54481.

CONFERENCES

CALIFORNIA

Mendocino: Shereen LaPlantz's Basketry Symposium. The Mendocino Art Center in northern California will host a basketry symposium August 26-30, 1985. Five full days of 16 workshops, ranging from seaweed basketry to traditional New England splint and Shaker baskets. *For information:* Mendocino Art Center, PO Box 765, Mendocino, CA 95460.

San Jose: The 32nd Annual Conference of Northern California Handweavers will be held Saturday and Sunday, April 27-28, 1985 at the San Jose Convention Center, 291 South Market St. San Jose, California. The conference will concentrate on the transitions which take place within the fibers, the threads, the colors, the designs, the weaver, and the culture. *For information:* Registrar, CNCH '85, 495 Knoll Drive, Los Altos, California 94022 or Dail Ann Koehler, Publicity, CNCH '85, 1064 Santa Cruz Ave., Menlo Park, CA 94025.

San Diego: The 1985 Conference of Southern California Handweavers will be held May 18-19, 1985 at the Convention and Performing Arts Center, 202 C Street, downtown San Diego. Malin Selander, internationally known Swedish weaver, and Ed Franquemont, expert on Peruvian textiles and culture, are the featured speakers. *For information:* Deni D. Goodman, 95 Antiqua Court, Coronado, CA 92118.

COLORADO

Lakewood: Rocky Mountain Basket Conference, "Innovations, New Ideas, Different Directions," Aug. 17, 18, 19/workshops: Aug. 20, 21, 1985. Sponsored by Red Rocks Community College at the Sheraton Inn, Lakewood, Colorado (Den-

ver area). For information: Nancy Goes, 2580 S. Ivy St. Denver, CO 80222.

FLORIDA

St. Augustine: The Florida Tropical Weavers Guild will hold its annual convention at the Ponce de Leon Lodge and Country Club in St. Augustine, Florida, April 12-14, 1985. Theme for this event is: "Heirlooms from Our Looms." For information: Chris Weaver, 110 Lime Court, Middleburg, FL 32068.

INDIANA

Bloomington: Indiana University. "Fibers Alive in '85," Midwest Weavers Conference; June 7-10, 1985. General sessions will feature Diane Itter and Shereen LaPlantz. Mini and Maxi Sessions in the areas of weaving, spinning, dyeing and related interests will be offered. Exhibits by individuals and guilds plus commercial exhibits and special displays will be open. Post conference workshops will be held June 10-13 for those who register for extended study with an artist. The Bloomington Spinners and Weavers Guild will host the Conference. For information: Jeune Baker, 4198 W. Tramway Road, Bloomington, IN 47401.

MICHIGAN

Midland: Michigan League of Handweavers, Divergence '85. "Focus on Design," June 21-23, 1985 at the Northwood Institute, Midland, Michigan and featuring Anita Mayer, Diane Sheehan, Ann Sutton. For information: Eleanor B. Safford, 22724 Nowlin, Dearborn, MI 48124 (313) 562-7236.

MISSISSIPPI

Fulton: American Crafts Council Southeast Region Winter Conference, February 22-23, 1985. ACC-SE will hold its winter conference on the campus of Itawamba Junior College in Fulton, Mississippi. The schedule includes panel discussions and workshops by nationally prominent artists such as Sam Maloof in furniture, Andrea Gill in ceramic, Ke Francis in object photography and Jean Thickers Francis in hand-made paper. Enrollment is limited, workshops will be filled on a first come first served basis. In conjunction with the conference there will be a National Invitational Furniture Exhibition. For information: Robert Reedy, Program Coordinator, Art Dept., Itawamba Junior College, Fulton, MS 38855 (601) 862-3101 ext. 264.

NEW JERSEY

Glassboro: Mid-Atlantic Fiber Conference, July 12, 13 and 14, 1985, Glassboro State College, Glassboro, New Jersey. Brochures available from Jean West, 212

Route 28, Bridgewater, NJ 08807. For other information: Mary Ellen Fanning, Conference Coordinator, 133 Rodney Circle, Bryn Mawr, PA 19010.

NEW MEXICO

Albuquerque: The Intermountain Weavers Conference 1985. Albuquerque, NM August 1-4, 1985. Twenty workshops and six seminars offered, given by a roster of nationally and internationally recognized leaders in textile arts field. All-fibers exhibit juried by Clinton McKenzie, open to US. For information: Carmen Jones, 230 Dewey Ave., Cedar City, Utah 84720.

NEW YORK

Buffalo: Eastern Great Lakes Fibre Conference, June 28, 29, 30, 1985. Sponsored by The Buffalo Weavers Guild of Buffalo, New York. "The Business of Art, The Art of Business." For information: Evelyn Krantz, 109 Enola St., Kenmore, NY 14217 (716) 874-2161 or Mabel Harber, 87 Drummond Crescent, Fort Erie, Ontario L2A 1I4 (416) 871-4352.

TEXAS

Austin: Contemporary Handweavers of Texas, Inc. biennial conference, "Universal Rhythms," March 21-24, 1985. H. Theodore Hallman is the keynote speaker. For information: Christine J. Martell, Route 6, Box 497, Leander, Texas 78641.

WASHINGTON

Tacoma: Tacoma Weavers Guild and other Puget Sound guilds invite you to the 1985 Association of Northwest Weavers Conference at Pacific Lutheran University, Tacoma, Washington, June 13-16, 1985. Pre-conference workshops commence on Monday June 10. For information send SASE to: Tacoma Weavers Guild, P.O. Box 64295, Tacoma, WA 98464.

CANADA

QUEBEC

Montreal: The annual conference of the Association of Quebec Weavers will be held May 24th and 25th, 1985 at the Holiday Inn (Downtown), 420 Sherbrooke St. W., Montreal. Main Speaker: Ann Kristin Rosling from Sweden. Includes bilingual seminars and workshops, exhibitions, suppliers, etc. For information: Erika Hofmann, 5057 Perron, Pierrefonds, Quebec H8Z 2J2.

TO ENTER

Deadline February 1, 1985 Handwoven in Southern California: An exhibit of woven work by Southern California Weavers. April 13-June 9, 1985, Fullerton Museum

Center. Sponsored by South Coast Weavers' Guild and Fullerton Museum Center. Slides due February 1. Maximum 2 entries/person. 2 slides/entry. Entry fee \$10/person. For entry form send SASE to: "Handwoven in Southern California," Fullerton Museum Center, 301 No. Pomona, Fullerton, CA 92632.

Deadline February 15, 1985 The 28th Annual Guilford Handcrafts Exposition, July 18, 19 & 20, 1985. Sponsored by Guilford Handcrafts, Inc. Open to all crafts media: wood, glass, clay, fibers, metals, etc. Application fee \$10. Deadline for application and slides (5) is Feb. 15. Cash awards. For information: Fernn Hubbard, Guilford Handcrafts Expo, 1985, P.O. Box 221, Guilford, CT 06437.

Deadline March 1, 1985 Spotlight '85, June 25-July 26, 1985. Sponsored by the American Crafts Council Southeast Region and held in conjunction with the ACC-SE Summer Conference, June 27-29 at Longwood College in Farmville, VA. Open to all artists/craftspeople in AL, FL, GA, KY, LA, MS, NC, SC, TN, VA, WV. Juried by Kenneth Bates and Ray Pierotti. Exhibition opens at the ACC-SE Conference and selected pieces will travel to approx. 10 art centers and museums. Slide entries due March 1. For prospectus write: Spotlight '85, Art Dept., Longwood College, Farmville, VA, 23901.

Deadline March 6, 1985 Judged exhibit and fashion show to be held in conjunction with the Contemporary Handweavers of Texas Conference, "Universal Rhythms," March 21-24, 1985 in Austin, TX. For information: Judi Goolsby, 4902 Raffee Cove, Austin, TX 78731

Deadline March 15, 1985 Applications are now available for booth space at the Ozark Foothills Craft Guild's 23rd Annual Spring Show and Sale, April 19, 20, & 21, 1985, in Mountain View, Arkansas. This three day craft fair is held in conjunction with the 23rd Annual Arkansas Folk Festival, a city-wide music and folklore celebration with an estimated attendance of 50,000 in 1984. For information: James Sanders III, Director, Ozark Foothills Craft Guild, P.O. Box 800, Mountain View, AR 72560.

Deadline March 15, 1985 International Basketry Competition—over \$1,700.00 in prizes, full color poster of award winners. Juried exhibition, no geographic restrictions. Exhibition sites, The Mendocino Art Center (CA) and, tentatively, The Chicago

◆ STUDY & TRAVEL ◆

Botanic Gardens, timed for each center's basketry symposium. Slides due March 15, 1985. \$15.00 entry fee, 5 slide limit. Send SASE for entry form to Press de LaPlantz, 899 Bayside Cutoff, Bayside, CA 95524.

Deadline March 22, 1985. "PATTERNS," a multimedia exhibition open to all media: clay, fiber, metals, wood, graphics, photography and painting is sponsored by the Guilford Handcrafts Center, Guilford CT. For application send SASE to: PATTERNS, Guilford Handcrafts, Inc., P.O. Box 221, 411 Church St., Guilford, CT 06437.

Deadline March 25, 1985 *Small Expressions '85* "When less is more." A juried exhibition for HGA members, cash awards. One entry (2 slides)/member \$10. Entry deadline March 25. Show dates July 22-25 New England Weavers Seminar, Amherst, MA. Works for this exhibit must be made using one or more of the following techniques: weaving, basketry, handmade paper or felt and should not exceed 12" x 12" in size. For membership information and show prospectus, send business size SASE to Handweavers Guild of America, Inc., 65 LaSalle Road, West Hartford, CT 16107.

Deadline August 13, 1985. "BLACK & WHITE," a multimedia exhibition open to all media: stone, clay, wood, metals, fiber, graphics, photography and painting. For application send SASE to: BLACK & WHITE, Guilford Handcrafts, Inc., P.O. Box 221, 411 Church St., Guilford, CT 06437.

no deadline stated *Fiber Celebrated 1985* (formerly titled *Fibers 85*). Juried fibers exhibit in conjunction with Intermountain Weavers Conference, August 1-28, 1985. Open to all areas of fibers. No geographical restrictions. Juror: Clinton McKenzie. Jurying by slides. Send SASE (legal size) for prospectus, February 1, 1985 to Helen Garner, 3041 Missouri Ave, Las Cruces, NM 88001.

no deadline stated *Triangle Weavers and the Chapel Hill Handweavers Guild 13th Annual Festival of Weaving* will take place at the Horace W. Williams House, 610 E. Rosemary St., Chapel Hill, NC from March 16-March 31, 1985. All North Carolina weavers are eligible to enter this non-juried show. No entry fee. For information: Triangle Weavers, P.O. Box 3055, Chapel Hill, NC 27515.

STUDY

CALIFORNIA

Berkeley: The Pacific Basin School of Textile Arts announces its Lecture Schedule for January-March, 1985. The School also offers intensive classes during Winter and Spring Breaks. For information: John Sheridan, The Pacific Basin School of Textile Arts, 1659 San Pablo Ave. at Virginia, Berkeley, CA 94702 (415) 526-9836.

Mendocino: The Mendocino Art Center, Textile Apprenticeship Program will now have Artists in Residence during winter and spring. For information: Lolli Jacobsen, Program Coordinator, Textiles, Mendocino Art Center Textile Apprenticeship, 45200 Little Lake St. P.O. Box 765, Mendocino, CA 95460 (707) 937-0228.

MISSOURI

Fayette: Announcing the opening of The Weavers' School. In association with The Weavers' Store, The Weavers' School offers classes in complex weaves designed for students interested in expanding from four to more shafts. A sequential arrangement of Saturday and/or weekend classes from April to October begins with drafting and moves through the use of 8-10 shaft jack and countermarche looms and the Swedish drawloom. Special week long classes on specific related topics such as double weave coverlets, damask, multi-block pattern designing as well as individualized instruction are also planned. Send for class schedule and information to: Madelyn van der Hoogt, The Weavers' School, Route One, Fayette, MO 65248 or Barbara Overby, The Weavers' Store, 11 S. 9th, Columbia, MO 65201.

NEW MEXICO

Santa Fe: Charlotte Funk will give a two-day twill tapestry workshop April 20-21, 1985, sponsored by the Las Tejedoras Weaving Guild, Santa Fe, New Mexico. For information: Sara Gilstrap, PO Box 9001, Santa Fe, New Mexico 87504 (505) 983-8058.

NEW YORK

New York: New York Guild of Handweavers Lecture Series: Jan. 26, 1985, 12:30 PM—slide lecture on Damask on a Drawloom by Ethel Stein; Feb. 23, 1985, 12:30 PM—slide lecture by Nancy Halpern; March 30, 1985—Japanese Shibori Dyeing; April 27, 1985, 12:30 PM—Joan Wortis, "Approaching the Marketplace Professionally." All events held at the YWCA of New York, 610 Lexington Ave. (53rd St.), New York City. For information: Pat Epstein, New York Guild of Handweavers, 215 W. 83rd St., New York, NY 10024 (718) 789-5866.

OHIO

Oberlin: Charles Lermond offers a variety of workshops at the Loom Shed for 1985. For information: The Loom Shed, 278 S. Pleasant St., Oberlin, Ohio 44074.

NORWAY

Molde: Workshops for experienced rose-malers, weavers, and woodcarvers will be held in Molde, Norway, June 16-June 30, 1985. Sponsored by The Norwegian-American Museum. For information: Vesterheim Workshops in Molde, Lila Nelson, Norwegian-American Museum, Decorah, Iowa 52101.

TRAVEL

Holland-West Germany-Switzerland: Textiles Exploration VI, 17 day tour, August 29-Sept. 15, 1985 with optional 4 day workshop following the tour. Includes the Biennale, lace, silks, tapestries, and damask weaving. Conducted and researched by Barbara Baggeroer and offered by Fullerton Travel Center, 124 Laguna Road, Fullerton, CA 92635.

China: Textiles Tour to China, April 5-24, 1985. The tour will include visits to museums, historical sites and areas of scenic beauty as well as opportunities to observe the design and production of contemporary textiles. For information: Penny Drooker, RFD 1, Box 2180 Witchcot Road, Sanbornville, New Hampshire 03872 (603) 522-3144.

Yugoslavia and Hungary: Prof. Tom Muir Wilson and Sherry Clark will be leading craft tours to Yugoslavia and Yugoslavia/Hungary in June and July of 1985. The tours will feature visits to shops and studios of working craftspeople and folk artists, small-scale workshops and industrial facilities, in addition to the special attractions unique to each country.

Holland and Belgium: Holland/Belgium Craft Tour, April 19-May 5, 1985. For information on these and other 1985 craft tours to Korea, Hong Kong, China, Scandinavia, Ireland, Morocco: Prof. Tom Wilson/Sherry Clark, Directors, Craft World Tours, 50 State St., P.O. Box 243, Pittsford, NY 14534 (716) 385-4434, (evenings) 548-2667.

Bolivia: The Ancient Weaving World of Bolivia, a tour led by Lynn A. Meisch, July 12-27, 1985. Participants will hear talks by Lynn and other experts in Bolivian weaving, attend local markets, and have the opportunity to buy the best of Bolivian folk art, to try their hand at spinning and weaving and to meet first hand indigenous Bolivian spinners and weavers. For information: Holbrook Travel Inc., 3520 NW 13th St., Gainesville, FL 32609. (904) 377-7111.

Reviews

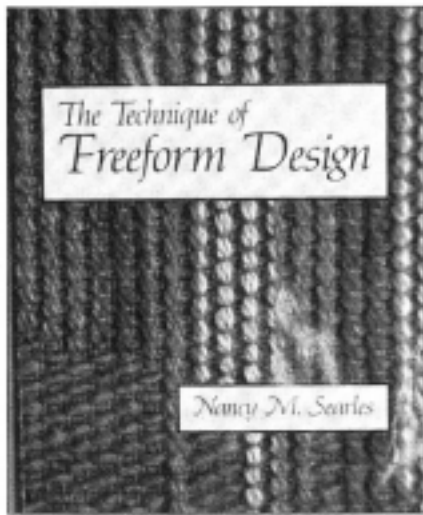

The Technique of Freeform Design

by Nancy M. Searles

Valparaiso, Indiana: Home Mountain Publishing Co., Inc., 1984. 160pp. (Order from: Weaver's Way, P.O. Box 230, Crown Point, Indiana 46307.

If you are looking for a way to develop handwoven designs as a result of the weave structure and if you are limited to four harnesses, this is the book for you. Nancy Searles leads the reader through a series of steps which produce an effect similar to the damasks and brocades normally woven on a draw loom or Jacquard loom. In fact, the introduction, entitled "Heritage," includes a capsule history of these looms, as well as the use of the dobby head and computers to control harness action. The culmination of this brief overview is the freeform design technique developed by Ms. Searles. She defines the technique as a "system comprised of one threading sequence which is repeated selvedge-to-selvedge, and which can be treadled to produce at least two different weave structures by using separate harness combinations for each of the weaves." Essentially, the technique is a development of pick-up methods where a sequence of sheds is picked up on one or more sticks, the combination of sheds is then opened with a shed sword, and the shuttle is thrown—or pushed—from selvedge to selvedge. In Ms. Searles' approach, the shuttle itself is used to "pick up" a variety of sheds in its trip across the warp.

The book is divided into two sections: the first covering nine structures which are derived from traditional four harness block weaves such as twill, Summer and Winter, and bronson lace; and the second covering

two-weft weaves which are heavier. The text proceeds in a detailed and easily followed fashion. Drafts and diagrams clearly direct the process. A number of photographs illustrate design possibilities, although my own inclination would have been to avoid some of the more "homey" graphic designs. I did especially like the ample feel of the book. The layout uses white space to set off the photographs and the type is of sufficient size to make reading the next step while seated at the loom a reasonable undertaking. I also like the inclusion of a "suitable projects" section under each weave structure chapter to guide the reader.

One of the most attractive features of *The Technique of Freeform Design* is the "insights" column at the inner edge of each page. Included here are comments on the process, additional ideas on making it easier, and thoughts which are helpful but which might interrupt the descriptive flow of the main text. Described are such topics as the "heritage" of a particular weave, the use of color, how to tie the warp to the front apron rod, and an edge finishing method. Also included are inspirational words by other authors—Thoreau, Mark Twain, Robert Frost, Leo Rosten to name a few, who have commented on weaving in relation to the whole web of life. Especially effective are the quotations from the author's great-grandfather, Elbert Hubbard, himself an author and teacher. The final page carries this sentence from him: "The best service a book can render you is, not to impart truth, but to make you think it out for yourself." This book plays that role, inspiring and guiding the reader to find satisfaction in exploring a new way to handwoven design.

Marjorie Ford-Pahlmann

Damask and Opphamta with Weaving Sword or Drawloom

Lillemor Johansson.

Translated by Susan Jones.

Stockholm: LT's Förlag, 1984. 167 p.

The first chapters in the book go into the long history of Swedish weaving, and the use of special equipment used in their historical weaves; and the development of their weaving schools. This history is most interesting. It tells of the special pieces individual weavers made for the Monarchy. Pictures show how well these pieces have been preserved. Later chapters bring us right up to the present, using the same techniques and tool. The use of the more complicated drawloom and drawloom attachments is discussed.

Damask weave is based on the same principle as a turned twill, but the ground weave is satin, usually 1,4 and 4,1. Opphamta is a weave in which the pattern is based on long floating weft inlays on a tabby or basket weave ground. They are both discussed in this book because the same equipment is used in weaving them. This equipment consists of weaving sword, long-eyed heddles, half-heddle sticks, or drawloom arrangements. This is slow weaving, but worth the time.

The illustrations, diagrams and explanations of the making and use of these tools are excellent.

The weaving schools in Sweden at the present time, are discussed, and also the weaving of various contemporary individuals is traced, with pictures of their weavings and the looms they use. Directions with threadings and methods used are included.

If you have a four, eight or twelve harness loom and wish it had more harness capacity, this book is for you. It is not a book for the beginner, but for the experienced weaver who knows what his/her loom can do. It will tell you explicitly how to increase your harness power, and show you with diagrams and pictures just how to do it inexpensively. I do recommend this book.

Irene K. Wood

The Law (In Plain English) for Craftspeople

Leonard D. DuBoff

Edited by Michael Scott

Seattle: Madrona Pubs, c1984. 139 p. paper. ISBN 0-88089-003-7

The Law (In Plain English) for Craftspeople by Leonard D. DuBoff is designed to be a guide for the non-lawyer/craftsperson to the often complex area of art related law. In many ways, the book accomplishes this purpose, giving the non-lawyer much useful general information regarding those areas of the law most craftspeople will be unable to avoid in doing business. The book should be required reading for any person considering the world of art as his or her livelihood.

Mr. DuBoff, himself a lawyer, succeeds in explaining important legal concepts in "plain English." He clearly explains basic legal problems and hits the high points of more complex areas of the law, such as trademark and copyright. Many non-lawyers, craftspeople and others, do not always know when they have a legal problem or legal issue: if it is not something familiar like being sued or divorced, most people

assume that others will behave reasonably and honestly and that things can be worked out. This can often be a very costly error. Mr. DuBoff gives the craftsperson the necessary knowledge to recognize a legal problem when s/he encounters one, and to be aware of those situations where legal problems may arise.

Mr. DuBoff also emphasizes a very important aspect of legal awareness—that it is much easier to do something right in the beginning than to try and fix it when it goes wrong. Usually, this means that the understanding or agreement should be put in writing, since most legal issues confronted by craftpeople will be in the area of contracts of some kind. In most cases, as the book explains, oral contracts are as enforceable as written contracts, but are much more difficult to prove if later contested. The time it takes to write an agreement down is usually time well spent.

Some areas of the law, such as patents, copyright, estate planning and incorporation almost always demand the assistance of an attorney. The information given by Mr. DuBoff in these areas is useful in that it allows the craftsperson to prepare the necessary information for his attorney, to ask his attorney the right questions, and to better evaluate the work his attorney does for him. It should not, however, be regarded as sufficient information to enable the craftsperson to deal with these legal problems on his own. The decision on whether to consult an attorney is usually an economic one: one does not ask one's attorney to review a contract worth \$50.00, but it is usually wise to have your attorney review one for \$50,000.00. Mr. DuBoff's book therefore can be helpful; but when the craftsperson confronts a legal issue common sense should tell him that he cannot always handle it himself.

Carrie L. Hess, Attorney
Meyer, Njus, Johnson & Nettles
Minneapolis, MN

Clothing from the Hands That Weave

Anita Luvera Mayer

Loveland, Colorado: Interweave Press, 1984.
162p. spiral bound. ISBN 0-934026-14-9

Creating cloth to be worn on the human body is one of a weaver's greatest challenges. It requires many skills beyond the scope of operating the loom—you must be a designer, technician, sculptor, and engineer. Successful garments are often the result of a lot of trial and error. This painful process discourages many would-be gar-

ment weavers from venturing into the world of clothing.

Have hope! Anita Luvera Mayer has written a book to demystify the process of creating handwoven clothing. *Clothing from the Hands That Weave* covers all aspects of the process. Working with ethnic traditions and modern function and fashion, we are led through the process of designing, weaving and finishing garments. Anita presents a system for the weaver to use when faced with the challenge of creating a garment. Her holistic approach to clothing deals with every aspect—from the psychological to the functional.

Written in a very personal style, Anita brings the excitement of creating and shares with us the growth she has experienced through her weaving.

This is an attractive book, full of clear and detailed drawings. A section of color photos of Anita's work is a special treat. The information presented on weaving garments is very accurate and well explained. Subjects covered include a look at eth-

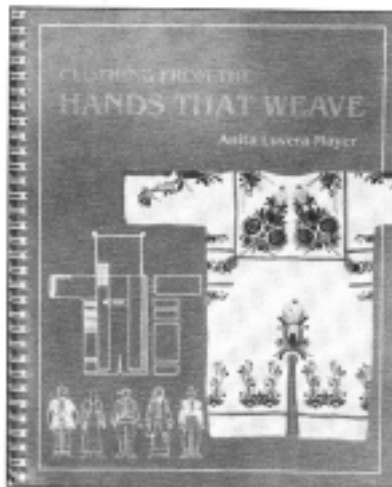

nic tradition in clothing, a summary of basic shapes for the weaver, how to make garments fit, how to systematically approach the challenge of weaving a garment, designing the fabric and finishing techniques for both fabric and garments.

In addition, Anita shares many examples of her work along with a personal narrative about their creation. These examples run the gamut from "Two-Drink Dress" (which required two drinks to give her the courage to wear it) to "Sweetie Pie"—a vest named for the angora goat that provided the raw materials.

Clothing is a very personal expression for the weaver. Anita Luvera Mayer has written a very personal book about her approach to handwoven clothing. Even if you never intend to weave anything to put on your body, you will enjoy this chronicle

of Anita's knowledge and life.

Rose Allen

From Craft to Industry: The Ethnography of Proto- Industrial Cloth Production Edited by Esther N. Goody.

Cambridge: Cambridge University Press, 1982.
220pp. cloth.

Although this attractive little book, edited by the British social anthropologist, Esther Goody, is written from a sociological/economic point of view, it will be of interest to handweavers, particularly production weavers.

After a somewhat technical introductory essay on various schemata for proto-industrial production (i.e., the first steps in industrial production) of cloth in various cultures, such as medieval Europe and 16th century China, four essays follow which treat the production of handwoven cloth and/or the tailoring of such cloth in four different cultures, both for domestic and export markets.

The first essay, on the Daboya handweavers and dyers of northern Ghana, focuses on handwoven cloth production and includes sections on warping, dyeing, skeining, and weaving. The discussion of the weaving process is integrated into a larger discussion of kinship, specialization, apprenticeship, and how the different levels of skill correlate with the apprenticeship system. The master weaver's sophisticated handling of young apprentices may provide some insights to production weavers who hire outside workers or have apprentices themselves. The section on the selling of cloth will sound extremely familiar to American handweavers. Cloth is sold five ways: wholesale; as retail yardage; as retail production work; retail as ready made clothing; and retail custom orders. Finally, the description of the Daboya weaver's development of ikat weft yarn, while probably not the spontaneous "invention" that Goody implies, provides an amusing example of how process (using one shuttle rather than two) determines aesthetic.

The second essay, while not specifically about handwoven cloth, is concerned with tailoring in Kano City in northern Nigeria. Much of the essay presents statistical information about Kano City tailors, such as census data. There are however relevant aspects that make the essay interesting to the handweaver. Certainly "another way of coping with the uncertainties of the market for artisan-made clothing is to supplement earnings from tailoring by obtaining wage-paying jobs . . ." (Pokrant, p.

125) applies here as well as in Kano City. Another problem for Kano City tailors and other textile craft workers was the seasonality of their market and the subsequent time-crunch, particularly around Ramadan. The same time-crunch affects American weavers around Christmas.

The essay on the Indian garment industry is probably the most distant from handweaving concerns. It deals, in large part, with Paville Fashions, a private family-run firm that specialized in women's garments for the export market. However, the author, D. A. Swallow, sees a great deal of overlap between the handloom industry and the garment export industry and goes into some detail about the former. Thus this essay will be of interest to both handweavers and anyone who has purchased an Indian "gauze" blouse.

The last essay concerns the Harris Tweed industry of the outer Hebrides Isles of Scotland. Judith Ennew devotes much space to the history of the islands and the industry, and provides some eye-opening examples of the value of creative advertising and myth-making. Descriptions of the equipment used, in particular, the Hattersley loom, which is a type of fly-shuttle loom that is operated without hands, by pedaling, will be of some interest. The current state of turmoil caused by management's proposal that all weaving be done at a single location as well as be woven on looms with twice the width of currently used looms, is discussed in detail. Anyone interested in a closer look at the workings of the Harris Tweed industry will enjoy reading this essay.

One point shared by Indian and Harris Tweed handweavers, not shared with their American counterparts, is government subsidy of handweaving. While such systems have plenty of problems, such as direct government input into production and frequently, low wages, it is a means of continuing the handweaving industry.

There are many things that American handweavers and textile craft workers do share with the craftspeople in the four cultures discussed. These include the problems of training employees, keeping up with changing fashions and government regulations. There are many ways of coping with the tentative nature of the textile industry which include low overhead, specialization, advertising, and production and design flexibility. Unfortunately, a recurring theme among many of the textile workers in India, Scotland and Nigeria is that they would like to get into another line of business. However, not all feel this way. A Harris Tweed weaver echoed the sentiments of many handweavers in this country when he

stated: "Harris Tweed has been good to me. I left being an electrician 21 years ago to start. I like to be free. You can please yourself. When you are working as a weaver, you are working and being paid by results and we have produced something for everyone's benefit. . . ." (Ennew, p. 186).

One final note: while this collection makes fascinating cross-cultural reading for any handweaver, especially the last two essays, its small size and hefty price tag make it come out to around \$2.40 an ounce, about the price of some very nice silk yarn. Better to buy the silk and read this at a university library or get it through interlibrary loan.

Elisha P. Renne

News

SHEEP TALES magazine has been acquired by Graphicom Inc. *Sheep Tales* editor Ruth Hodges has agreed to continue serving as editor. *Sheep Tales* will continue to be directed to the farm flock shepherd, while **Lamb and Wool Production**, another Graphicom magazine, will be directed to the intense production manager.

THE TEXTILE BOOKLIST. Due to many requests and much continued interest, *The Textile Booklist* will continue publication. The ownership of the quarterly publication has just been transferred to Kaaren Buffington and Kay Sennott Hofweber by R. L. Shep. *The Textile Booklist* will be published out of Arcata, California.

TEACHING FOR LEARNING. *Teaching for Learning* is a newsletter for anyone who teaches weaving and feels s/he would benefit from an exchange with other teachers. Published by Debbie Redding, it is specifically designed for non-academic fiber teachers. Published bi-monthly except summer and is available on a subscription basis only, \$10/year. For information: Weaving Futures, Box 7295, Boulder, Colorado 80306.

Books received

Park Weaves; based on Dr. William G. Bateman's manuscript. Edited by Virginia I. Harvey. Freeland, Washington: HTH Pubs., 1984. (Shuttle Craft Guild Monograph 37). 96p. paper. ISBN 0-916658-39-2.

Woven Fashion. By Vivienne Bateson. New York: Van Nostrand Reinhold, 1984. Translation of: *Vetements Tissés*. 142p. cloth. ISBN 0-442-21036-8.

Dyeing for Fibres and Fabrics. Edited by Janet DeBoer. Brisbane, Queensland, Australia: The Australian Forum for Textile Arts, 1984. 81p. paper. ISBN 0-959-4551.

Handmade Felt. By Marianne Ekert. Sunshine Bay, Eastbourne, New Zealand: Textile Tools, 1984. 40p. paper. ISBN 0-9597707-0-4.

Textiles for Today's Church; A guide to creating fiber art. By Roslyn J. Hahn. Warren, Ohio: published by the author, 1984. 39p. spiral bound.

Cottage-Crafts & Fibers. A reference book. By Nancy Merle Holtz-Carter. Bremerton, Washington: Holtz-Carter Pubs., 1984. 128p. paper. ISBN 0-9613701-0-6.

The Mad Weave Book. By Shereen La Plantz. Bayside, California: Press de La-Plantz, 1984. 76p. paper. ISBN 0-942002-01-6.

Surface Design for Fabric. By Richard M. Proctor and Jennifer F. Lew. Seattle: University of Washington Press, 1984. 192p. ISBN 0-295-95874-X (cloth), 0-295-96087-6 (paper).

Learning to Weave. By Debbie Reading. Loveland, Colorado: Interweave Press, 1984. 232p. spiral bound. ISBN 0-934026-15-7.

An Illustrated Guide to Making Oriental Rugs. By Gordon W. Scott. Seattle: Pacific Search Press, 1984. 104p. paper. ISBN 0-914718-94-0.

The Handloom Weaves. By Harriet Tidball; Additions by Virginia Harvey. Enlarged Edition. Freeland, Washington: HTH Pubs., 1984. (Shuttle Craft Guild Monograph 33). 48p. paper. ISBN 0-916658-40-6.

IN THE NEXT ISSUE

DESIGNING FOR AN INTERIOR • by Philis Alvic
LOG CABIN RAG RUGS • by Janet Meany
8-HARNESS KROKBRAGD RUG • by Marilyn Holtzer
MÄRTA MÅÅS-FJETTERSTRÖM'S TEXTILE DESIGNS • by Claire Selkurt
CONTEMPORARY FINNISH TEXTILES • by Liisa Kanning Ojala

◆ PRODUCTS ◆

Reviews

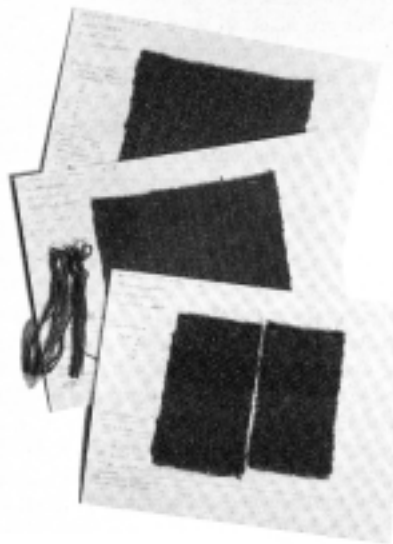

Wilde Yarns 2-Ply Soft Clothing Yarn

Supplied on 8 ounce cones of 720 yards (1440 yards/pound) by John Wilde & Bro., 3705 Main Street, Philadelphia, PA 19127.

From the 18 colors that range from rusts, purples, greens and blues, the colors Persimmon, Clove, Elderberry and Raisin were selected.

Sampling was at 12 epi in plain weave, 2 crepe weave variations, and 2/2 twill. Pick count at 10 ppi under tension gave a balanced weave.

The yarn is relatively firmly spun 5-twist, woolen spun. It is easy to work with during warp winding and the large cones are convenient. Only 2 joins appeared during warp winding; one, a conventional overhand knot; the second a smooth splice rather than a knot—for experimentation this was left in the sample warp with the splice passing through heddles and reed with no abrasion and being concealed in the web with no special handling—this would be of special importance for efficiency when winding long production warps or warping multiple threads.

On the narrow 7" sample warp the sheds were clear. At 45" and 12 epi there was a tendency for some stickiness in the sheds which cleared easily with changing the shed and pushing the beater from the fell line toward the heddles simultaneously.

The fulling and finishing possibilities of this line of yarn offer the weaver a great range of choice. Hand washing resulted in a firm yet soft fabric. A gentle machine wash on a "wool" cycle increased the softness; fringe at 1" and 4" lengths maintained a groomed appearance. A slight surface

fuzziness resulted as well as noticeable increased density of the fabric when processed through a complete 14 minute regular machine wash cycle. The 2/2 twill sample, when processed twice through the regular machine wash cycle developed a thicker, loftier and fuzzier hand. It appears that a wide variety of pleasing fulling results could be satisfactorily controlled without concern of overprocessing or felting. Further experimentation with setts, structures and brushing would increase the possibilities.

Ruth Arnold

Warp-Aide by Warp Ways

Warp Ways of Placerville California is marketing a device that expedites the raddle warping process.

The *Warp-Aide* consists of a stable support system that holds two sets of lease sticks, a raddle and a tie-on bar. The device attaches easily to the loom back beam with



thumb screws, and is a wonderful substitute for tension devices many of us have hastily rigged with rope and dowels or broomsticks. A block for raising the harnesses is also included, so that the warp will be wound on in a straight, level path. (It is also a useful aid in threading.)

To use the *Warp-Aide*, it is necessary to wind a warp with two crosses at one end. The two sets of lease sticks are placed in the double cross, the tie-on bar is placed in the warp end-loops and lashed to the loom apron bar, and the warp is spread in the raddle. The warp chain is placed at the front of the loom and the warp passes through the harness frames as it is wound on from front to back, the two sets of lease sticks acting as a tensioning device.

We tested the *Warp-Aide*, using a 6-yard warp of single-ply *Vippelo* wool from Schoolhouse Yarns. It went on with a mini-

imum of tangling, and only one broken thread at the very beginning.

Warp Ways custom builds the *Warp-Aide* to fit snugly on the back beam of any loom. A loom specification sheet is included with their order form, and 6 to 8 weeks should be allowed for delivery. Price ranges from \$114.95 to \$174.95, depending on loom width.

Also available from Warp Ways is *Reed-On*, a pair of brackets that fit on the front loom beam and hold the reed in a flat, level position for easier slewing. To obtain a brochure and order form, write Warp Ways, 4961 Cedar Ravine, Placerville, CA, 95667.

Karen Searle

News

Norwood Looms

Norwood Looms, manufacturers of quality handweaving looms for nearly 40 years, is pleased to announce that it has taken over the manufacture and distribution of the Cranbrook Loom. The Cranbrook Loom, a counter-march loom internationally recognized for its strength, balance, and superb craftsmanship, is now being built in Fremont, Michigan in conjunction with the Norwood Loom. For further information on either the Cranbrook or the Norwood line: Norwood Looms, P.O. Box 167, Fremont, Michigan 49412.

Cotton Clouds

Cotton Clouds has just given birth to their newest child, *Baby Pearly Perle*. Twenty selected rainbow colors of 5/2 mercerized cotton yarn are now packaged on convenient four ounce (525) yard mini-cones. New colors will be added seasonally. This new packaging of their popular machine washable and colorfast yarn will allow customers a wider selection of a variety of colors. *Baby Pearly Perles* are a Cotton Clouds exclusive. Send SASE for samples and information. Cotton Clouds, Rt. #2 Desert Hills #16, Safford, Arizona 85546.

Cotton Clouds now carries 2" x 1/2" woven labels that can easily be sewn into any handmade gift or sale item. Cotton Clouds other new label is a durable paper hang tag 2" x 3" which states "It's real. . . . 100% cotton" on one side and "Easy Care Instructions" for machine and hand washing printed on the back. Both of the "100% cotton" labels and hang tags are available retail and wholesale from Cotton Clouds. Send a legal SASE for samples and prices.

Henry's Attic

Henry's Attic announces two new textured cotton yarns. Monte Cristo II, Swiss cotton replaces Monte Cristo in their line. Poppa Bear II is a domestically produced chenille which will be offered in addition to Poppa Bear Chenille from Spain. For information: Henry's Attic, 5 Mercury Ave., Monroe, NY 10950.

Straw Into Gold

Straw Into Gold, Inc. is pleased to announce that "Jaws," the carding machine which has produced our "Rainbow Batt" for the last five years, has moved to a new home. "Jaws" will be living and working for Alden Amos in Jackson, California. Alden will not only continue to supply Straw Into Gold with Rainbow Batt, but will be shipping from Jackson to retail and wholesale customers. Rainbow Cheese roving, long unavailable due to shortage of time and skilled labor at Straw, will again be produced on "Jaws" by Alden. For information: Alden Amos, 11178 Upper Previtali Rd., Jackson, CA 95642.

Ihana Brushing Service

The country's only professional machine brushing service for handweavers has relocated from St. Louis, MO to Denver, CO. Ihana offers weavers a unique finishing alternative. Through a machine brushing process, it raises a plush, high nap on virtually any fabric woven from wool. The process also blends colors and surface patterns for more beauty—and created layers of new air pockets for added warmth.

Practiced in Europe for generations and introduced to America by Ihana in 1982, machine brushing transforms blankets, scarves, shawls and yardage into luxuriously finished works. For a free, no-obligation information packet containing a

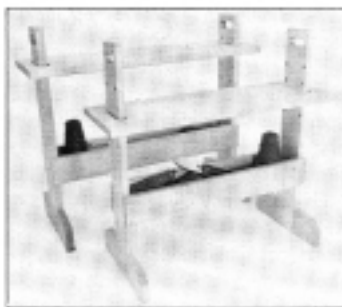

small brushed sample, full pricing information and recommended yarns and setts: Ihana Brushing Service, 1037 S. University, Denver, CO 80209 (303) 744-0411.

Harrisville Designs

Harrisville Designs has added a large loom bench to their line of accessories. The benches are made of solid hardwood, with a tool box for convenient storage, side handles for portability, and wooden pegs for adjustable height. The Small Bench is 27½" long and adjusts to 22" in height, and the new Large Bench is 32" long and adjusts as high as 25". For more information: Harrisville Designs, Harrisville, NH 03450.

Harrisville Designs has introduced a new nub-type tweed yarn in 22 colors. The 100% pure virgin wool yarns feature unusual accents against subtle heather blends and are available in 1 ply and 2 ply for knitting and weaving. For a fabric swatch and sample card: Harrisville Designs, Harrisville, NH 03450.

Harrisville Designs has announced their new Model 50, 50" Floor Loom, built with sturdy mortise and tenon construction in New England Rock Maple. The four harness, 6 treadle combination and the unique "snap chain" tie-up system allow for quick and easy multiple tie-ups. The Model 50 features floating lamms and swinging harnesses for a smooth, quiet action. A pump handle warp advance and friction brake release give complete tension control which can be adjusted to fit any need. Weaving width: 50". For information: Harrisville Designs, Harrisville, NH 03450.

Herald Looms

The Herald Loom Bench, made of mountain ash and available in a natural or walnut finish, has been redesigned for shipment by UPS. The bench has a hinged seat with a stop chain, a large storage space below the seat and open end bins for spools, shuttles, etc. The bench measures 10½" wide by 39½" long and 23" high with a seat 23½" long. For information: Herald Looms, 118 Lee St., Lodi, Ohio 44254.

You Can Make MORE MONEY Weaving Rugs



• A fascinating and profitable full or spare time business right in your home. It's easy to weave beautiful, serviceable rugs. Always a big, year around demand in every community. Easy to operate floor model loom weaves 36" wide, comes already threaded, fully equipped — ready to weave. We furnish complete information on looms and all equipment with offer given below.

Send 25¢ for our complete catalog, sample card, and low prices on carpet warps, rug fillers, shears, rag cutter, beam counter, looms and parts. Also: rags — prints — and looper clips, in 10 and 50 lb. bales. If you now have a loom, please advise make and width it weaves.

OR. RUG CO., Dept. 1574, Lima, Ohio 45802

Pendleton

FABRIC CRAFT SCHOOL

Enjoy a creative vacation in Sedona's spectacular red rock country. Workshops in all phases of handweaving and related subjects.

Instructors: Inga Krook, Kalmar, Sweden; Mary Pendleton, Sedona, Arizona.

College credit optional. Write for brochure. P.O. Box 233 • Sedona • Arizona 86336 602-282-3671

Archer

Custom-carded batts for spinning or felting

342 heathered colors

100% Premium Quality New Zealand Romney Fleece

Samples \$4

2½ oz. batt \$4; 16oz. batt \$20

Archer, Box 80023, St. Paul, MN 55108

◆ THE WEAVER'S MARKET—CLASSIFIEDS ◆

EQUIPMENT

TEXSOLV LOOM TIE-UP SYSTEM Canadian distributors. For sample kit, send \$1.00, refunded with order. WOOLHOUSE, Box 315, Armstrong, B.C., Canada V0E 1B0.

FLOOR & TABLE LOOMS designed by Rollo Purrington, made by the Norrises, 52W Willowbrook Road, Storrs, CT 06268. SASE for brochure.

BASKET REED—flat, round, flat-oval. **WOODEN HOOPS**, 3 inch to 23 inch, **HANDLES**, oval, dee, u, rectangle. Catalog \$1.00. **EARTH GUILD**, Department WJ, One Tingle Alley, Asheville, NC 28801.

Loom for Sale: New Custom-Craft 4H, 36" floor model. \$575. Call collect (414) 854-4325.

PUBLICATIONS

FIBRE FORUM is the tri-annual colour magazine of the textile arts for Australia. Subscriptions in 1985 are \$16 in the USA and \$20 in Canada. Subscribe through R.L. Shep, Box C-20, Lopez Island, WA 98261. Fee should accompany subscription.

BOSTON WEAVERS' GUILD MONOGRAPHS

VERSATILE BRONSON by Dorothy S. Burton. Instructions, drafts, designs, photographs, bibliography, \$7 postpaid

MORE LINEN HEIRLOOMS by Constance D. Gallagher \$5 postpaid

PROCESSING AND FINISHING HAND-WOVEN TEXTILES. \$4 postpaid

WEAVERS' WISDOM 250 aids to happier weaving. \$4 postpaid

Please order from:
Mrs. G. Clifford Goodband
361 Norwood Street
Sharon, Mass 02067

HANDMADE FELT by Marianne Ekert; the complete guide to making shaped boots, mittens, waistcoats, hats, bags or whatever! Clearly illustrated throughout. Send US \$5.25 plus .75 p & h (\$2.00 airmail) to Textile Tools Ltd, Sunshine Bay, Eastbourne, New Zealand. Trade enquiries welcomed.



NEW revised edition
Send \$6.95 to: Indigo Press
DOROTHY T MILLER
5950 Fern Flat Rd
Aptos, CA 95003



Order form for **Free indigo seeds** in each book

The Unicorn

Books for Craftsmen

Please Our Craftsmen Friends
to Our Specialty



Send for our pleasant, and very useful, introductory package. It contains a set of Weaving Notebook Sheets, a Weaver's Note Pad, a Linen Gamp Instruction Sheet, and our annotated catalog of books on Weaving, Spinning and Dyeing. Send \$1.00 to The Unicorn, Box 645, Rockville, MD 20851.

PATTERN DEVICES FOR

HANDWEAVERS—125 pages, illustrated. Instructions for Beiderwand, damask, double weave, twills, supplementary warp and weft patterning using standard looms, modifications, and special devices including pick-up sticks, long-eyed heddles, pattern harnesses, and drawlooms. \$18.00 plus \$2.00 shipping. **DORAMAY KEASBEY**, 5031 Alta Vista Road, Bethesda, MD 20814.

FABRICS BY MELISSA—A unique, exciting shop-at-home fabric catalog, complete with actual swatches. Newest colors, textures and patterns. Low prices, fast delivery. No minimum yardage. Professional customer discounts. FREE spool of thread with first fabric purchase. Send \$4.00 for current catalog to: Fabrics By Melissa, PO Box 404 Dept. W, Leonia, N.J. 07605.

COMPUCRAFTS introduces "THE WEAVER" ©1983. An extremely powerful computer weaving drawdown program for the APPLE II PLUS or IIe. Up to 8 harnesses, 10 treadles, 280 warps, 160 wefts. Features color, magnification, rising and sinking sheds, printouts of pattern and draft in traditional or counted formats. Interactive and automatic treadling. Create a data-base of designs and drafts for later review and/or modification. Send \$49.95 for disk plus manual or for complete information contact **COMPU-CRAFTS**, RFD 2 Box 216, Lincoln, MA 01773.

STUDY

THE WEAVERS' SCHOOL: classes in complex weaves using 8+ shafts countermarche and jack looms and Glimakra drawlooms offered in association with THE WEAVERS' STORE, April–October 1985. One day, weekend, and week long classes plus individualized instruction. For class schedule and brochure and new 1985 catalogue of yarns and supplies write: Madelyn van der Hoogt, The Weavers' School, Route One, Fayette, MO 65248 or Barbara Overby, The Weavers' Store, 11 S. 9th St., Columbia, MO 65201.

TRAVEL

GREECE, JULY 15–AUGUST 5. Workshop and tour of traditional Greek weaving with Catherine Van Steen and Linda Griggs. Athens, Thessaly, Epirus, Lefkas Island, the Peloponnese, and 7 days weaving on Evia Island. Details: University of California Extension, Santa Cruz, CA 95064, (408) 429-2971.

SCANDINAVIA FOR WEAVERS. June 13–28, 1985. Denmark, Sweden, Norway. Escorted by Joanne Tallarovic. Optional instruction at Glimakra Loom Factory, Sweden. Weaving schools, Klippans, Midsummer festival. Info/brochure **RIVER CITY TRAVEL**, 19655 Detroit Rd., Rocky River, Ohio 44116: (216) 333-1600.

TEXTILES OF CHINA, April 5–24, 1985. Visit centers of ancient and modern silk production, major archaeological and historical sites. Send SASE for more information to: Penelope Drooker, Box 220, Sanbornville, NH 03872.

Ethnic Embellishments Newsletter



Collectibles from other
cultures
for the fiber art
enthusiast

send \$1. (applied to purchase) to:

Ethnic Embellishments
P.O. Box 4202, Colorado Springs, Co. 80904

YARNS, FLEECE, FIBERS

WOOL YARN FROM NEW ZEALAND—Buy direct for weaving and knitting. From \$3/lb. 100% wool yarn natural and coloured. Moth proofed and ready for use. US \$2 for sample card and brochure. **MODENA EXPORT**, Box 31, Takanini, New Zealand.

Tucson, Arizona
HEADIN' SOUTH?
Spinning-Weaving-Dyeing
Winter Workshop Schedule... SASE



Spin 'n Weave
2725 N Campbell Ave Tucson, Az 85719
(602) 323-9767

100% ICELANDIC WOOL—yarns in two weights: 9 natural "sheep" colors. Catalog and yarn samples: \$2.00. **GOLDEN FLEECE**, 12519 SE 203, Kent, WA 98031.

QUALITY NEW ZEALAND HANDCRAFT FLEECES

Beautiful fleece wool, specially bred for Spinners, Weavers and Handcraft people. Fleeces are clean, with long staples (5" plus) and weigh 6 lb.

Prices per lb: white and colored \$US 2.95. Postage etc. extra. Discount on group orders. Carded wool and yarn available. Brochures and samples, no charge.

Orders sent promptly
in very personal manner by
JANETTE MCKENZIE
"GORRIE DOWNS"
GRETA VALLEY, R.D.
NORTH CANTERBURY, NEW ZEALAND.

SILK CORDS

Shimmering silk cords in many colors and lengths for the quality minded designer. Excellent for use in fine art, clothing and accessories. Color samples \$3.50

The Cord Company
5611 Virginia Kansas City, Mo. 64110

GUATEMALAN HANDWOVEN FABRIC:
100% cotton. Unusual designs, contemporary and traditional. Very large selection, discount prices. Ideal for clothing and home furnishings. Sample \$2. Charlotte Eggleston, P.O. Box 7281, Santa Cruz, CA 95061-7281.

Fiber Headquarters of the Southeast

Complete Line of Spinning,
Dyeing, Weaving, Basketry
Supplies and Books.
Looms, Spinning Wheels,
Knitting Machines and Yarns

Millend Mailing List \$3.00 per year
(minimum, 4 mail-outs)

Yarn Samples: \$2.50 Basketry Samples: \$1.00
Spinning Samples: \$1.50 Bulky Yarns: .75

HOURS: Tues.-Fri. 10-5, Sat 10-4

Linda Snow - Fibers

3209 Doctors Lake Dr.
Orange Park, FL 32073
(904) 264-4235



STATEMENT OF INDEPENDENT ACCOUNTANTS AND ASSOCIATES

TO THE STOCKHOLDERS OF THE CORPORATION:

WE HAVE EXAMINED THE BALANCE SHEET OF THE CORPORATION AS OF DECEMBER 31, 1988, AND THE STATEMENT OF INCOME, STATEMENT OF CHANGES IN STOCKHOLDERS' EQUITY, AND STATEMENT OF CASH FLOWS FOR THE YEAR ENDED DECEMBER 31, 1988. IN OUR OPINION, THE FINANCIAL STATEMENTS PRESENTED ACCURATELY REFLECT THE FINANCIAL POSITION, RESULTS OF OPERATIONS, CHANGES IN STOCKHOLDERS' EQUITY, AND CASH FLOWS OF THE CORPORATION FOR THE YEAR ENDED DECEMBER 31, 1988.

INDEPENDENT ACCOUNTANTS AND ASSOCIATES

3000 W. WASHINGTON AVENUE
SUITE 200
MINNEAPOLIS, MN 55412
(612) 338-1111

SHEEPSKIN PIECES—cleaned, random sizes. Make rugs, vests, seatcovers. Instructions with order. 1 lb. \$4.00; 5 lbs. \$16; 10 lbs. \$28; plus shipping. CUSTOM HANDWEAVING, Box 477, Dept. WJ, Redondo Beach, CA 90277-0477.

MOHAIR-WOOL LOOP—NEW STOCK 17 colors. Also Cashmere and specialty wools. Samples: \$1 plus #10 SASE (39¢). CUSTOM HANDWEAVING, Box 477, Dept. WJ, Redondo Beach, CA 90277-0477.

SILK.SILK.SILK. New silk stock. 70 exciting colors. Quantities limited. Complete samples \$4. CUSTOM HANDWEAVING, Box 477, Dept. WJ, Redondo Beach, CA 90277-0477.

CRAFT SUPPLIES—basketry (28 sizes of reed and cane, 40 hoops and handles, tools and books), fiber (spinning, weaving, hand and machine knitting, dyeing, net-work, mill-end and new yarns), pottery, wood-carving, rug-making. Catalog \$1.00. EARTH GUILD, Department WJ, One Tingle Alley, Asheville NC 28801.

MILL END AND FIRST RUN YARNS. Natural and Dyed cottons, wools, synthetics. Samples \$1.00. Catalog \$1.00. EARTH GUILD, Department WJ, One Tingle Alley, Asheville, NC 28801.

100% WOOL YARN Wool mark R. Production overruns at mill end prices. More than 1,200 colors in weaving weights. Our computerised inventory system. Send \$5.00 for Stock Color Card, or SASE for prices & specials. SPINNING WHEEL YARNS, Dept. W5, PO Box 5076, Asheville, NC 28813.

The Weaver's Market classified advertising rate is .75 per word, \$15.00 minimum. **Deadline** for the spring issue is March 15. Pre-payment must accompany ads. Send your ad copy to: The Weaver's Market Classified, c/o The Weaver's Journal, P.O. Box 14238, St. Paul, MN 55114.

NEW!

from Dos Tejedoras Fiber Arts Publications

Double-Woven Treasures
from Old Peru



by Adele Cahlander
with Suzanne Baizerman

Dos Tejedoras
3036 N. Snelling
St. Paul, MN 55113
(612) 646-7445

Advertisers Index

- Archer 88
- Arrowmont 55
- AVL Looms 92
- Ayottes Designery 54
- Beka Looms 60
- Boston Guild Monographs 89
- Bradshaw Mfg. Co. 37
- The Cord Company 90
- Cotton Clouds 8
- The Craftsman's Touch 8
- Dos Tejedoras 17
- Daft Dames 18
- Ethnic Embellishments 89
- Kerry Evans 37
- Frederick Fawcett 8, 16
- Glimakra Looms 'n Yarns 2
- Gorrie Downs 89
- Grandor Industries 17
- Handweaver's Guild
of America 37
- Harrisville Designs 6, 7
- Henry's Attic 27
- Ident-ify Label Corporation 66
- Indigo Press 89
- Ironstone Warehouse 17
- Kagedo 27
- Leclerc 38
- Lucille Landis 55
- Macomber Looms 91
- The Mannings 18
- New England Weavers'
Seminar 17
- Masterweaver 44
- OR Rug Company 88
- Pendleton Shop 88
- Press de laPlantz 17
- PRO Chemical & Dye Co. 16
- Katherine Ramus 54
- Santa Fe Weavers School 55
- Schoolhouse Yarns 37
- School Products 8
- E. F. Shaw & Company 66
- Sievers Looms 16
- Silk City Fibers 66
- The Silk Tree 37
- Linda Snow 90
- Spin 'n Weave 89
- Surface Design Association 37
- Textilforum 18
- Treenway Crafts 17
- Tunestede 23
- Unicorn Books 89
- UnderCovers 18
- Väv Magasinet 55
- Warp-Aide 18
- Weaver's Journal
Publications 75, 76
- Westside Weaver 55
- Wilde Yarns 18
- Wonder Craft 27

AD-A-HARNNESS LOOMS®

—Traditional Quality—

AD-A-CAD/CAM SYSTEMS™

—Trendsetting Innovations—



MANUFACTURED BY

MACOMBER LOOMS

P.O. Box 186 Beech Ridge Road - York, Maine 03909 - 207-363-2808

—ESTABLISHED 1936—

Call or write today for our new catalog.

"I love my AVL, it made Production Handweaving a reality for me"

Brook Trout, Weaver, Santa Rosa, California



Photo by Christian Pedersen

"From the time, fifteen years ago, that I first sat down at a loom, in the Panama Canal Zone of all places, I knew that weaving held a special fascination for me.

After a few years of experimentation, I started to explore different ways to make my living as a weaver. I wove rugs, pillows, and yardage, but it took so long that they simply weren't profitable.

I gave up on the idea until one day in late 1980 when I saw my first AVL loom. I instantly knew that I'd found the perfect production loom.

Today, in just three years, my business has become highly successful. I now use three AVL

looms and my line of women's fashions "brook weaves," is carried in shops from Honolulu to Martha's Vineyard.

I can honestly say that I couldn't have done it without AVL."



AVL LOOMS

601 Orange Street Dept 34
Chico, California 95926
(916) 893-4915

Send \$1 for complete catalog

AVL, Now the possibilities are endless.